

Modelling of a Regenerative Liquid Propellant Gun

G.S. Dhami, S.G. Tatake, K.J. Daniel, A.A. Ghosh & K.R. Rao

Armaments Research & Development Establishment, Pune-411 021

ABSTRACT

In the development of liquid propellant guns (LPG), there are numerous interdependent parameters which affect the performance of the gun. There are some difficulties in arriving at the dimensions of its various components. To help in this task, computer simulation was undertaken to predict the performance of a conceptual gun. This is a sensitivity study aimed at exploring the relationship between the interdependent parameters. The parameters which have a direct bearing on the performance of the gun, like areas of cross-section of vents, differential piston dimensions, liquid propellant mass, and the combustion and reservoir chamber dimensions have been studied. The expected pressures and other parameters could be studied with the help of this model. This information gained from this model is thus helpful in the optimization of the design of LPGs.

NOMENCLATURE

A_p	Area of cross-section of barrel
A_z	Area of cross-section of piston head
A_r	Area of cross-section of reservoir
A_v	Area of cross-section of vents
C_d	Discharge coefficient of liquid propellant
F	Impetus of propellant
F_i	Impetus of igniter propellant
f_n	Energy lost in friction as a fraction of the projectile energy
F_z	Total force on the piston
H_b	Heat lost in the barrel as a fraction of total propellant energy
k	Spring constant
KE_g	Kinetic energy of propellant gases
Y	Displacement of the spring
$m(t)$	Mass of propellant reacted in time t
$m_i(t)$	Mass of igniter propellant reacted in time t
m_p	Mass of projectile
m_z	Mass of piston
$P_c(t)$	Pressure in combustion chamber
$P_r(t)$	Pressure in reservoir chamber
ρ	Density of propellant

$T_c(t)$	Temperature of gas in the combustion chamber
$T_o(t)$	Flame temperature of liquid propellant
$T_i(t)$	Flame temperature of igniter propellant
$U_c(t)$	Volume of combustion chamber at time t
$U_r(t)$	Volume of reservoir
$V_i(t)$	Velocity of liquid propellant through vent
$V_p(t)$	Velocity of projectile at time t
$V_z(t)$	Velocity of piston at time t
$x(t)$	Projectile displacement at time t
$z(t)$	Piston displacement at time t
β	Bulk modulus of liquid in reservoir, and Ratio of specific heats.

INTRODUCTION

There are several designs of regenerative guns¹⁻³ of which the following two designs were taken up for modelling:

- Simple in-line regenerative piston (Fig. 1(a)).
- In-line annular piston with tapered/uniform control rod (Figs 1(b) & 1(c)).

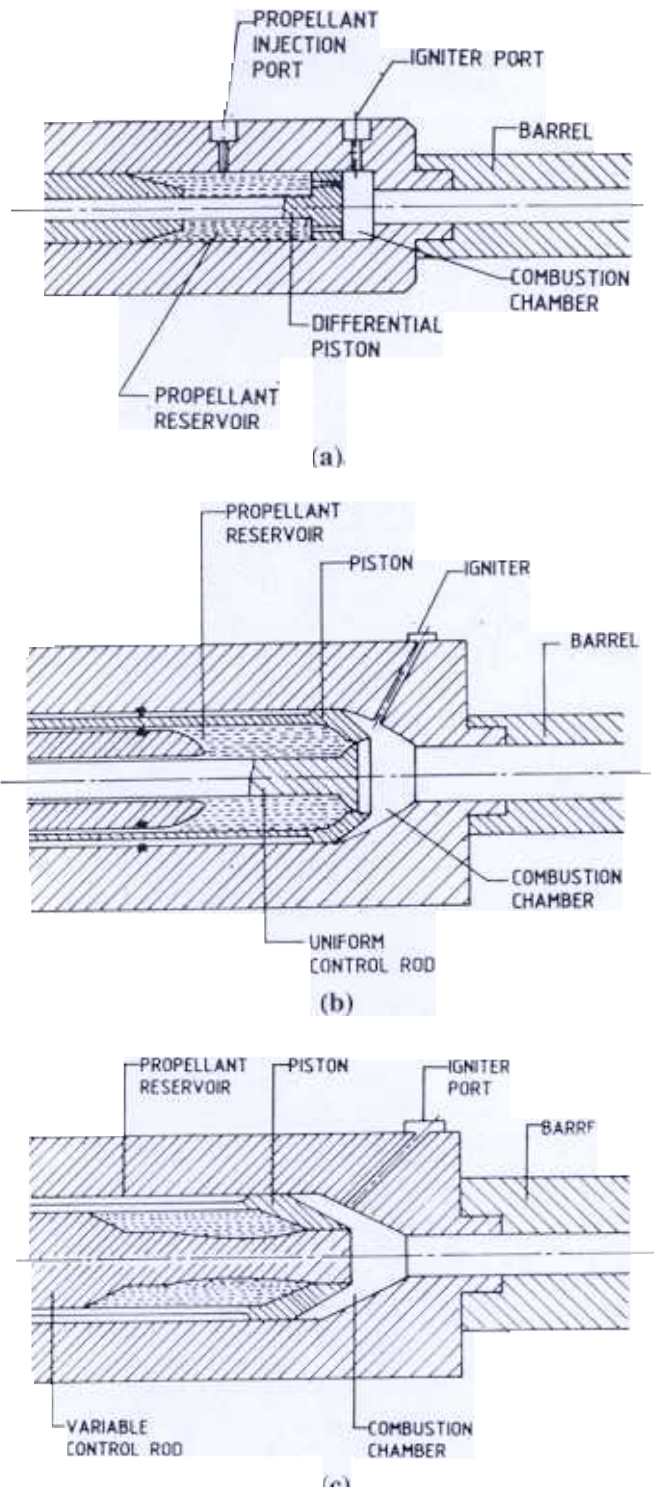

Figure 1 Regenerative liquid propellant guns modelled (a) simple in-line regenerative piston; in-line annular piston with (b) uniform; and (c) variable control rod.

In the regenerative liquid propellant gun (LPG), the area of the piston facing the projectile side is larger than the one facing the liquid propellant side. This

differential piston concept is responsible for the injection of the liquid propellant into the combustion chamber¹⁻³

2. MODEL

The model assumes that the initial pressure in the combustion chamber is generated by an igniter burning at a fixed rate. The injection process of the regenerative piston starts only after a certain pressure is reached. The equations for pressure and temperature in combustion chamber are given as

$$P_c(t) = \frac{(1-H_b) \times (Fm(t) + F_i m_i(t))}{U_c(t)}$$

$$\frac{(\gamma-1) \times \left(\int F_z dz + 0.5 \times (1+f_p) \times m_p \times V_p(t)^2 + KE_g \right)}{U_c(t)} \quad (1a)$$

$$T_c(t) = \left(\frac{(1-H_b) \times (Fm(t) + F_i m_i(t))}{(\gamma-1)} \right) \times$$

$$\frac{\int F_z dz + 0.5 \times (1+f_p) \times m_p \times V_p(t)^2 + KE_g}{\left(1 / \left(\frac{(1-H_b) \times Fm(t)}{(\gamma-1)T_o} + \frac{F_i m_i(t)}{(\gamma-1)T_i} \right) \right)} \quad (1b)$$

These equations are differentiated to obtain the required differential equations which need to be solved. The heat lost to the gun is assumed to be a fraction of the propellant energy. The heat lost due to friction is assumed to be a fraction of the kinetic energy of the projectile. It is further assumed that the entire mass of liquid propellant entering the combustion chamber reacts instantaneously.

The bulk modulus of the liquid propellant in reservoir changes drastically with pressure and is given by

$$\beta = A + B \times P_r(t) \quad (2)$$

where *A* and *B* are user input parameters which need to be estimated experimentally. As experimental data

were not available, reported data^{4,5} were used. The liquid is considered as compressible and the change in the density of the liquid propellant is given by

$$\frac{d}{dt} \rho(t) = -\frac{A_r \rho(t) \times V_z(t)}{U_r(t)} - \frac{dm/dt}{U_r(t)} \quad (3)$$

The pressure in the reservoir is given by

$$\frac{d}{dt} P_r(t) = \frac{\beta (A_r \times V_z(t) - C_d \times A_v \times V_l)}{U_r(t)} \quad (4)$$

In case of a gun with a simple in-line piston the area of the vent remains constant. In the other cases under study, the area of the vent depends on the position of the piston. The pressure difference across piston head causes the liquid propellant to be injected into the chamber and the mass flow rate is given by

$$\frac{d}{dt} m(t) = C_d \rho A_v V_l(t) \quad (5)$$

The coefficient of discharge C_d varies between 0 and 1 dynamically⁴. For simplicity a constant value has been used. The velocity of liquid propellant flowing through the vent is given by

$$V_l(t) = \sqrt{\frac{2(P_r(t) - P_c(t))}{\rho(t)}} \quad (6)$$

The mass flow rate of the igniter liquid propellant is a user-defined constant and lasts till the entire igniter liquid propellant is exhausted

$$m_i(t) = r(t)t \quad (7)$$

The pressure in the combustion chamber and the pressure in the liquid propellant reservoir generate forces which act at the ends of the piston. The spring action is used to buffer the piston at a predetermined piston position⁵. The equation of motion of the piston is given by the following two equations:

$$\frac{d}{dt} V_z(t) = \frac{P_c(t)(A_z - A_v) - P_r(t)(A_r - A_v)}{m_z} - ky \quad (8)$$

$$\frac{d}{dt} z(t) = V_z(t) \quad (9)$$

The only force acting on the projectile is from the pressure of the combustion chamber. The equations of motion are given by

$$\frac{d}{dt} V_p(t) = \frac{P_c(t) A_p}{m_p}$$

$$\frac{d}{dt} x(t) = V_p(t)$$

The initial velocity and displacement of both the projectile and the piston are zero. The projectile is assumed to be stationary till a shot start pressure is reached which depends on the projectile design. These define the starting conditions for Eqns (8)–(11).

The corresponding change in chamber volume is given by

$$\frac{d}{dt} U_c(t) = V_z(t) A_z + V_p(t) A_p$$

3. SOLUTION OF EQUATIONS AND RESULTS

The Eqns (1) to (12) are solved simultaneously using modified Euler's method. The software predicts the peak pressures in both chamber and reservoir, velocities of piston and projectiles, etc, for different input parameters. Table 1 gives the typical input parameters and Fig. 2 shows the time evolution of different parameters in the gun. The peak pressures are around 320 MPa and projectile velocity is around 1266 m/s. The predicted piston velocity at impact in the absence of the buffer spring is 75 m/s. The computer simulation code helps to design a suitable system which can act as a buffer for the piston. As liquid propellant is totally burned after about 3.5 ms the parameters, like liquid propellant density and bulk modulus are not defined and hence shown as zero in these results.

4. USE OF MODEL IN DESIGN OF GUN

4.1 Parametric Study

The combustion chamber was designed for a peak pressure of 320 MPa and a projectile mass of 360 g. Within these limitations the parametric study was undertaken with the aim of maximising the projectile velocity, kinetic energy and ballistic efficiency. Studies were undertaken to consider how variation in one design parameter affects other parameters. A variation in the chamber bore, vent area, mass of the liquid propellant, diameter of piston shaft and the initial volume of the combustion chamber effects the gun performance. The optimum parameters arrived at after several iterations

Summary of input data for the regenerative liquid propellant
gun simulation

Details of piston and shaft	
Mass of piston head	: 0.286 kg
Density of piston & shaft material	: 7930.000 kg/m ³
Area of piston head	: 18.086 cm ²
Length of piston head	: 20.000 mm
Diameter of piston head	: 48.000 mm
Diameter of shaft	: 22.000 mm
Mass of piston shaft	: 0.579 kg
Length of piston shaft	: 192.367 mm
Area of piston shaft	: 3.799 cm ²
Mass of piston (head + shaft)	: 0.866 kg
Spring constant	: 16.00 MN/m
Spring start position	: 100.00 mm
Number of vents	: 20
Diameter of each vent	: 5.000 mm
Area of cross-section of vents	: 3.925 cm ²
Coefficient of discharge C_d	: 0.95
Details of chamber and barrel	
Bore of chamber	: 48.000 mm
Bore of barrel	: 30.000 mm
Heat lost to barrel	: 10.000 per cent
Length of barrel	: 2.600 m
Initial volume of combustion chamber	: 60.000 cc
Details of projectile and igniter	
Mass of igniter propellant	: 1.500 g
Density of igniter propellant	: 1.430 g/cc
Impetus of igniter propellant	: 0.900 kJ/g
Total igniter propellant energy	: 5.400 kJ
Igniter mass flux into chamber	: 0.001 g/ms
Mass of projectile	: 0.360 kg
Shot start pressure of projectile	: 50.000 MPa
Energy lost due to friction	: 10.00 per cent
Details of liquid propellant reservoir and the liquid propellant	
Volume of reservoir	: 174.825 cc
Area of cross-section of reservoir	: 14.287 cm ²
Initial pressure in LP reservoir	: 0.100 MPa
Injection start pressure of	: 4.000 MPa
Length of reservoir chamber	: 122.367 mm
Mass of propellant	: 250.000 g
Density of propellant	: 1.430 g/cc
Impetus	: 0.900 kJ/g
Total propellant energy	: 900.000 kJ
Ratio of specific heats	: 1.250
Bulk modulus of LP	: 5350.000 MPa
Pressure dependence factor	: 9.110
Ratio of chamber/reservoir area	: 1.266

of the program are shown in Table 1. Figures 3-7 show the results of the parametric study.

4.2 Chamber Bore

Figure 3 shows that a bore of the combustion chamber of 48 mm is almost optimum giving the

maximum projectile velocity, kinetic energy and ballistic efficiency. The peak pressures for the reservoir and the combustion chamber are below 320 and 250 MPa, respectively for which the chambers have been designed.

4.3 Vent Area

It can be seen from Fig. 4 that a vent area greater than 3.925 cm² (20 vents) does not substantially increase the projectile velocity, kinetic energy and ballistic efficiency. Higher vent areas result in increased reservoir and combustion chamber pressures beyond designed values.

4.4 Mass of Liquid Propellant

Figure 5 shows that 250 g of liquid propellant is sufficient to achieve a velocity of about 1200 m/s for the design pressures. The ballistic efficiency is close to 30 per cent. Further increase in propellant mass may yield higher velocity but at the cost of lower ballistic efficiency.

4.5 Shaft Diameter

Shaft diameter of 22-25 mm is near optimum as seen from Fig. 6. These shaft diameters yield the maximum kinetic energy, projectile velocity and ballistic efficiency. The pressures are within allowable limits.

4.6 Combustion Chamber Initial Volume

Figure 7 indicates the initial volume for the combustion chamber should be kept above 40 cc to maintain pressures below designed values.

In these studies the shotout pressure is substantially low, indicating that most of the pressure was used to accelerate the projectile.

5. CONCLUSION

The above simulation code has been used in the initial design of the 30 mm regenerative liquid propellant gun. This was of considerable help in optimising the design.

Some parameters, like heat losses, friction losses in the movement of the projectile and piston have not been modelled. The liquid propellant is also considered to burn instantaneously on reaching the gun chamber. The size of the droplets and the burning rate of the

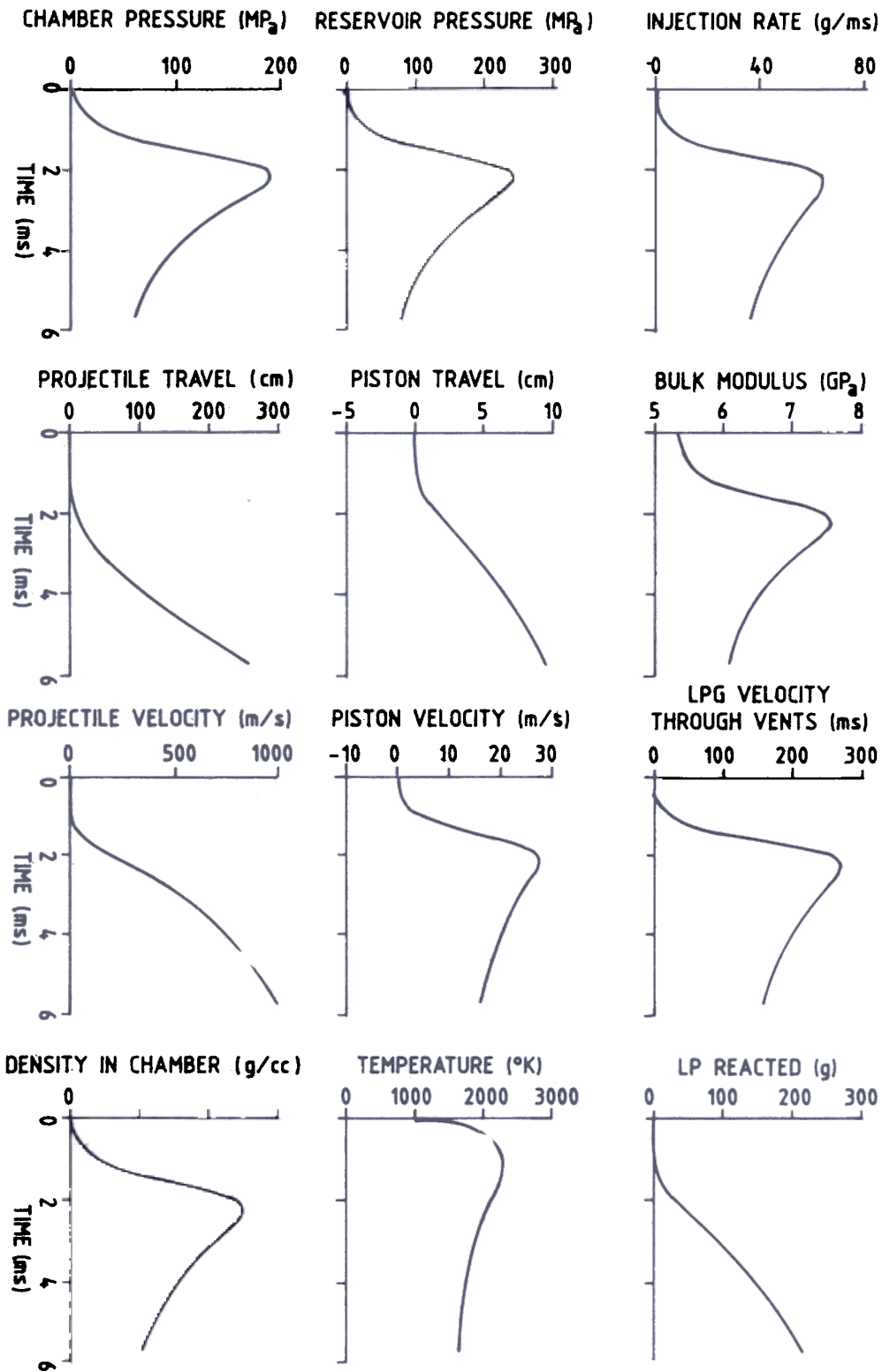

Figure 2. Time evolution of different parameters in the gun (Results obtained using input data of Table 1).

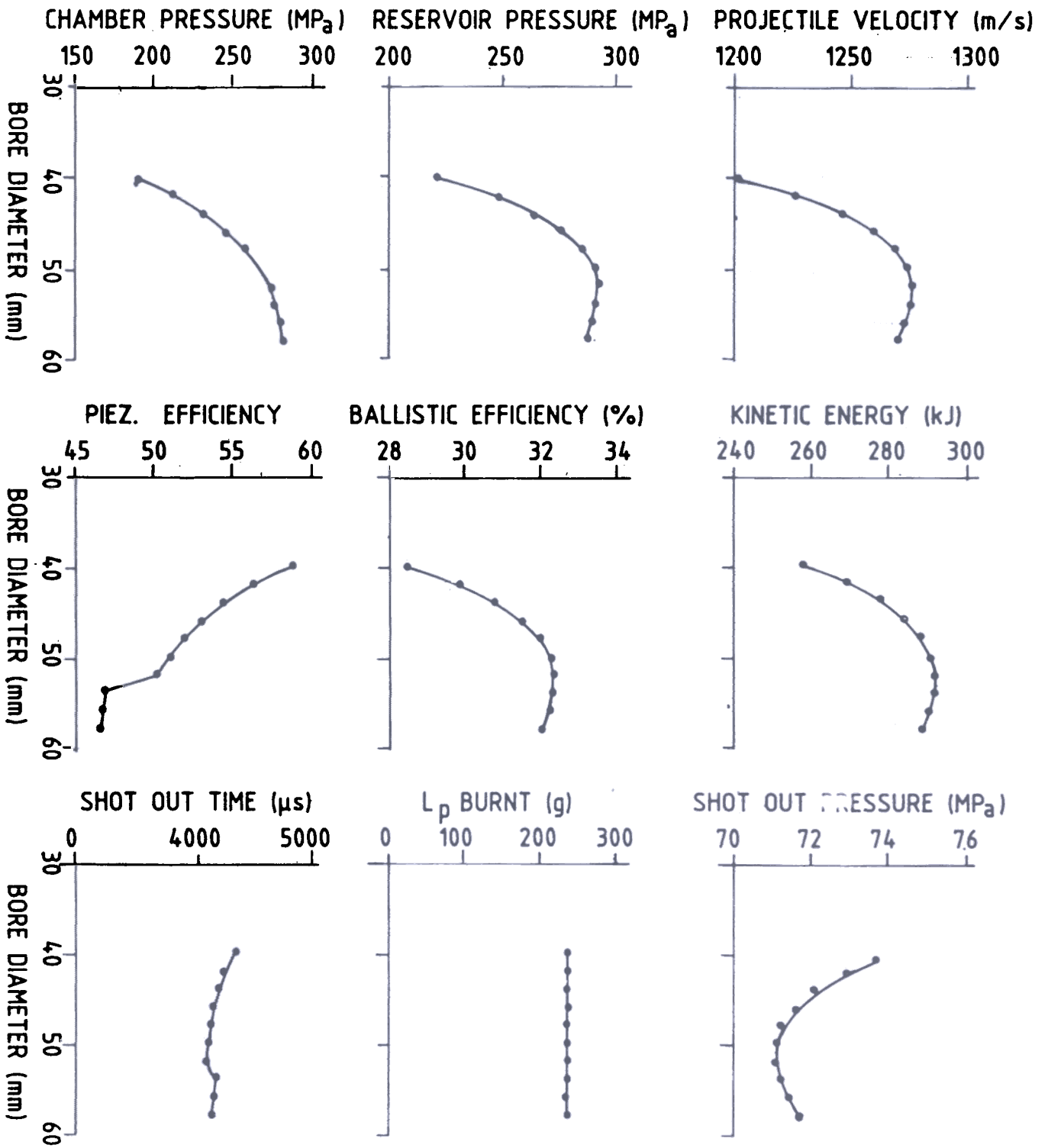

Figure 3. Parametric study for the effect of gun performance with variation in the chamber bore.

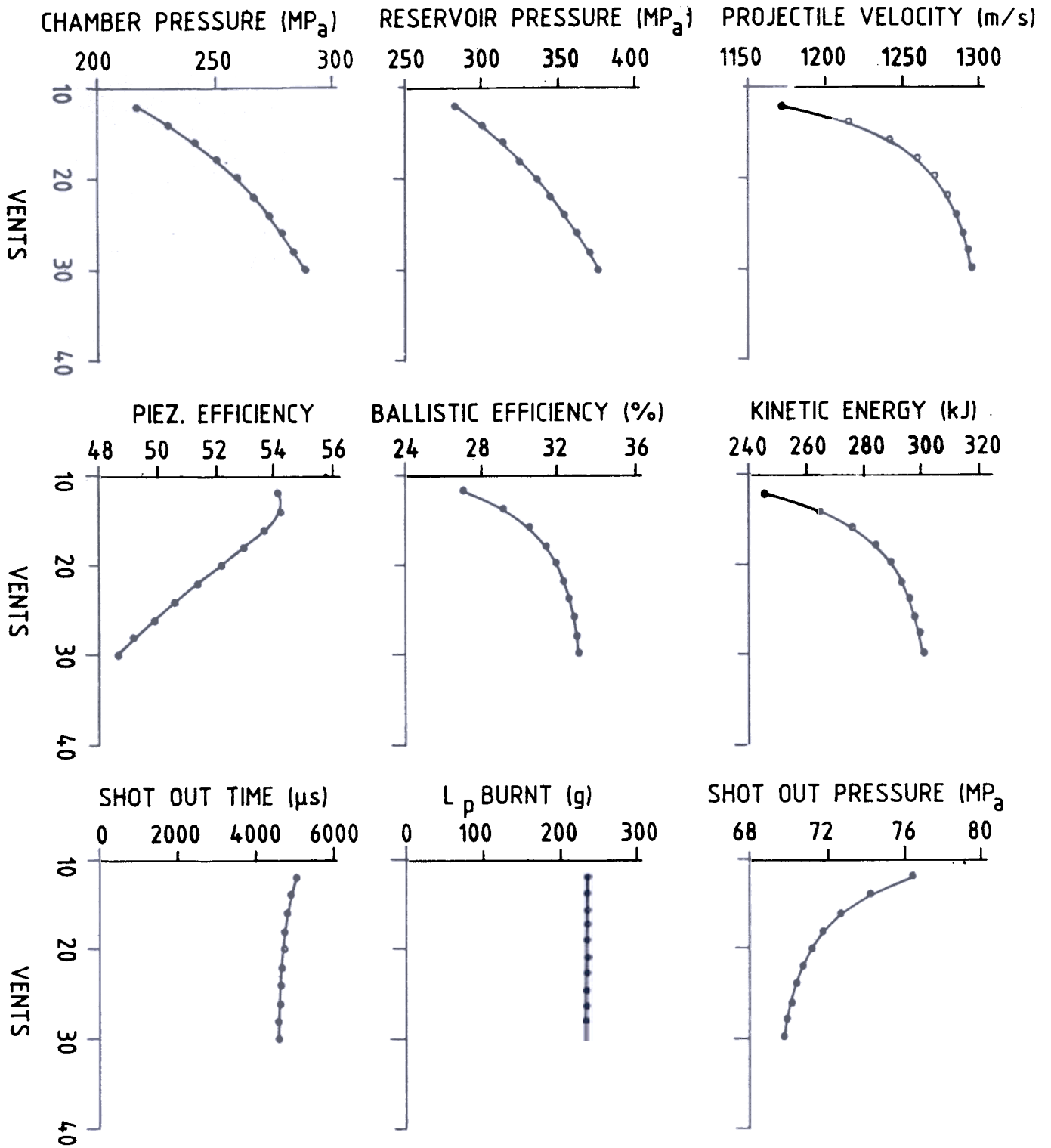

Figure 4. Parametric study for the effect of gun performance with variation in the vent area.

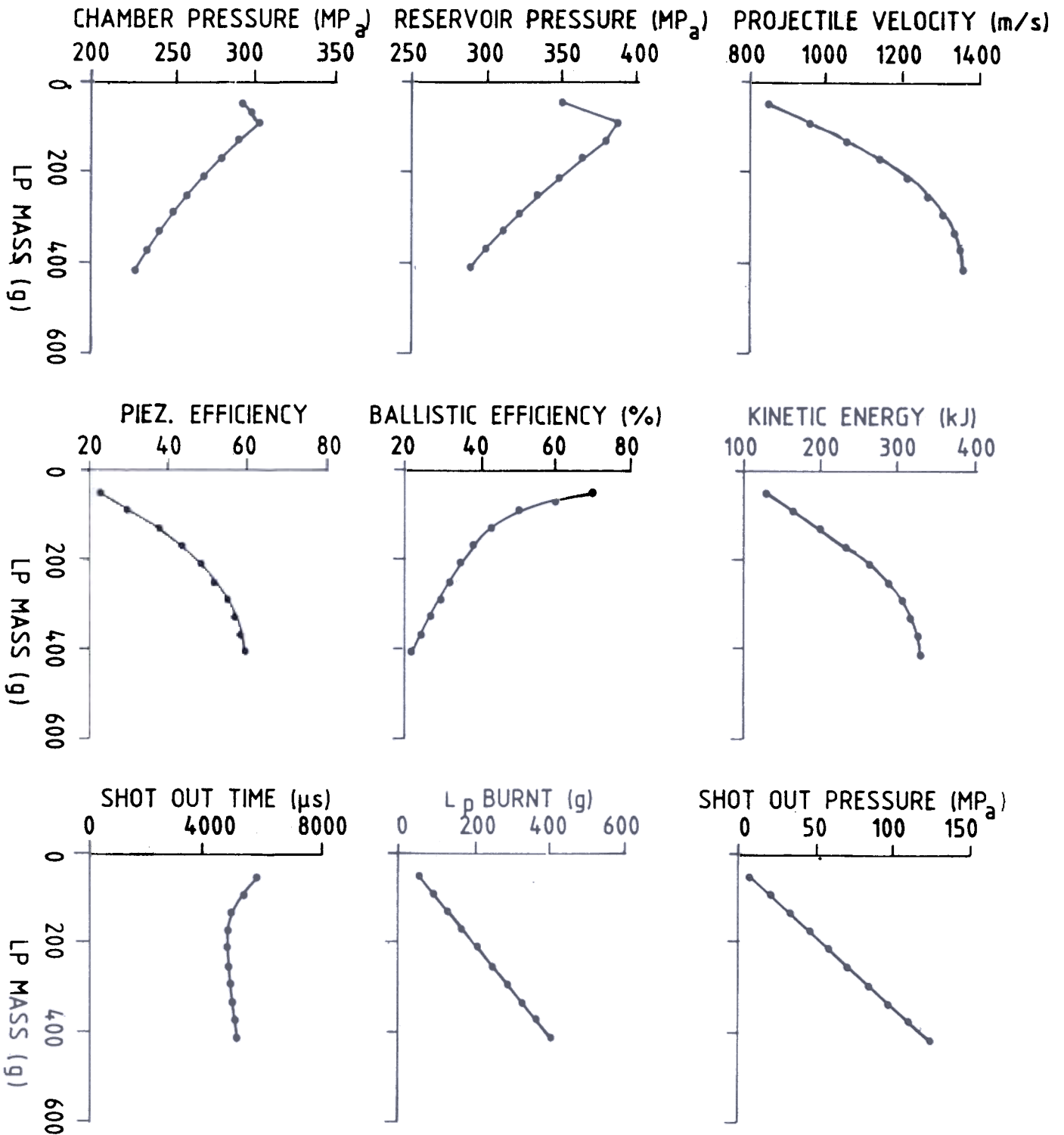

Figure 5. Parametric study for the effect of gun performance with variation of the mass of the liquid propellant.

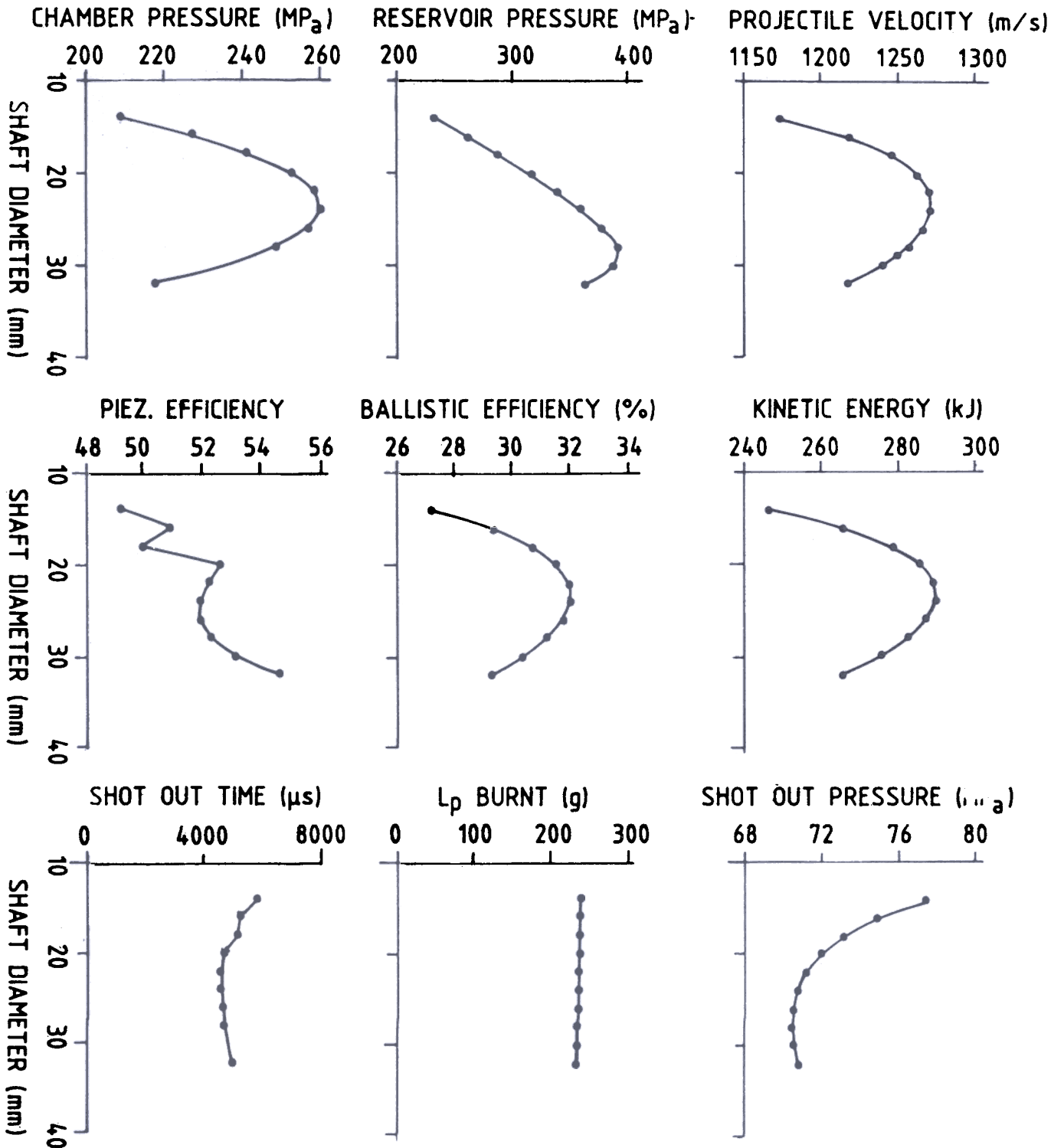
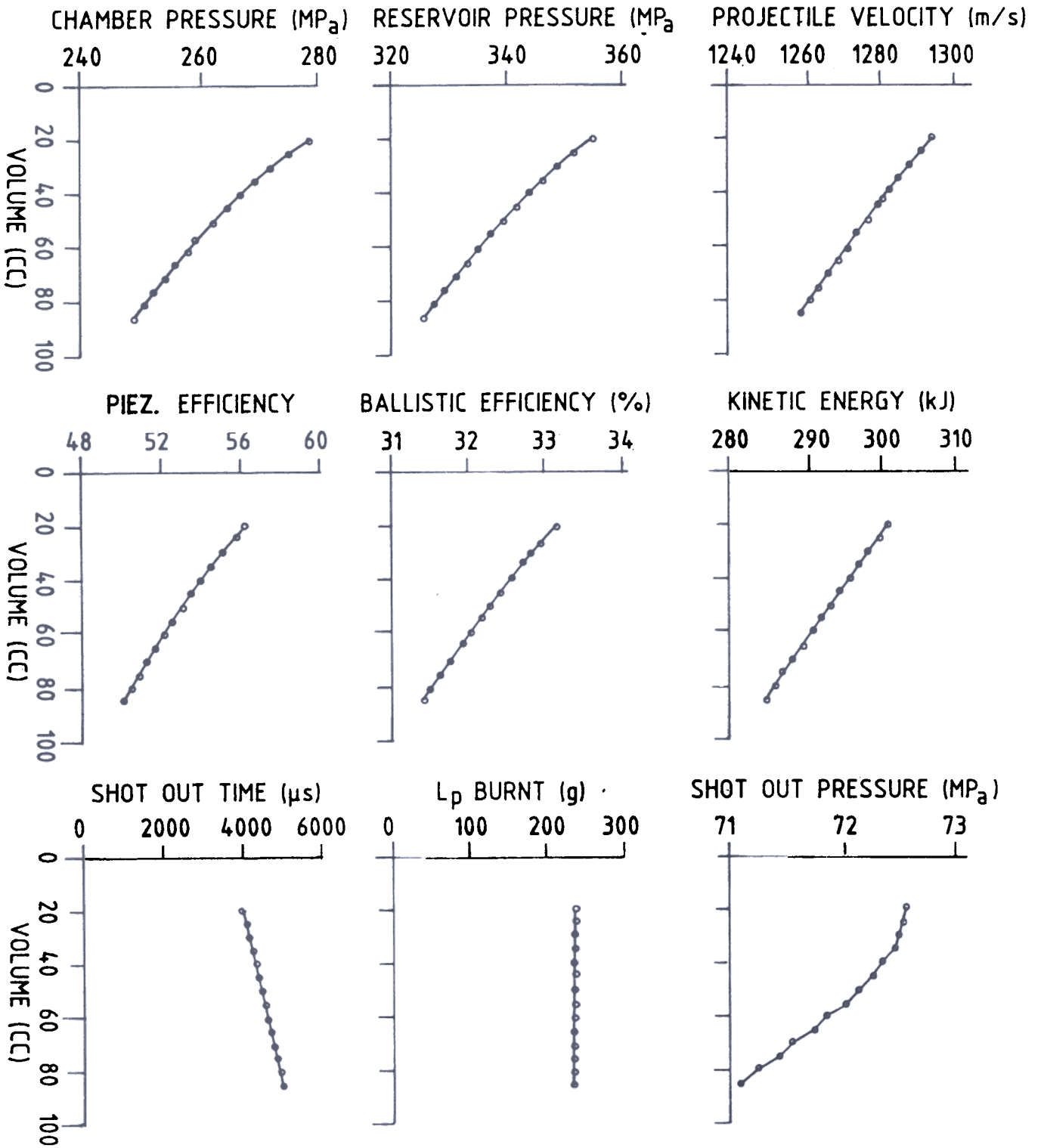

Figure 6. Parametric study for the effect of gun performance with variation in the diameter of piston shaft.

Figure Parametric study for the effect of gun performance with variation in the initial volume of the combustion chamber.



liquid propellant were not included in the model. More reliable values of the discharge coefficient (C_d) have to be experimentally estimated. Attempts will be made to incorporate these refinements in later models. The validation of this model in actual gun firing is being planned.

ACKNOWLEDGEMENT

We thank Maj Gen D Kapil, Director of Armaments Research & Development Establishment, Pune, for giving us the opportunity to present this paper. We are indebted for the facilities that were made available to us in the Establishment.

REFERENCES

Gun and Propulsion Technology, Edited by Ludwig Stiefel. US Army Armament Research & Development Centre, Picatinny Arsenal, New Jersey, American Institute of Astronautics Inc., 1988.

- 2 Torrence P. Coffee. A lumped code for regenerative liquid propellant guns. Technical Report BRL-TR-2948 of the Ballistic Research Laboratory, Aberdeen Proving Ground, Maryland.
- 3 Torrence P. Coffee. A updated lumped code for annular regenerative liquid propellant guns. Technical Report BRL-TR-2974 of the Ballistic Research Laboratory, Aberdeen Proving Ground, Maryland, December 1988.
- 4 Birk, A. & Reeves, P. Annular liquid propellant jets: Injection, atomisation and ignition. Technical Report BRL-TR-2780 of the Ballistic Research Laboratory, Aberdeen Proving Ground, Maryland, March 1987.
- 5 Pagan, Gordon; David, C.A. & Izod, Regenerative liquid propellant gun modelling. Proceedings of the Seventh Symposium on Ballistics, 12-19 April 1983.