

## Guidance Systems of Fighter Aircraft

K.N. Rajanikanth, R.S. Rao, P.S. Subramanyam, and Ajai Vohra

*Aeronautical Development Agency, Bangalore-560 017*

### ABSTRACT

Mission performance of a fighter aircraft is crucial for survival and strike capabilities in today's aerial warfare scenario. The guidance functions of such an aircraft play a vital role in meeting the requirements and accomplishing the mission success. This paper presents the requirements of precision guidance for various missions of a fighter aircraft. The concept of guidance system as a pilot-in-loop system is pivotal in understanding and designing such a system. Methodologies of designing such a system are described.

**Keywords:** Takeoff guidance, homing guidance, speed guidance, auto switch-over guidance, desired track guidance, landing guidance, slope guidance, angle of attack, heads-up-display, weapon delivery guidance

### 1. INTRODUCTION

Aircraft guidance forms an important aspect for realising the full potential of an aircraft since it permits the pilot to fly the aircraft safely within its flight envelope irrespective of its weight, load, distribution, and the environment in which it operates. An important benefit of having an effective aircraft guidance system is the improved pilot situational awareness. Primarily, the aircraft guidance goals are the availability, accuracy, and integrity.

To meet these primary goals, the aircraft mission profile is analysed to arrive at a set of guidance requirements during various phases of the flight. The guidance requirements translate into specific guidance functions for the aircraft. The design of these guidance functions necessitates to consider the various entities, which form a control loop. These entities are the computing element (the guidance function itself), the display element, the pilot, the

flight control system element, the navigational system element, and other sensor elements. The guidance function output needs to be transformed into effective display cues that help the pilot provide appropriate input to the flight control system. Proper choice and design of these cues and the instants of time at which these appear or disappear, significantly enhances the pilot-vehicle interface. The placement of a cue within the display surface and its relative positioning with another cue (considering that both belong to a related set) is critical for obtaining the maximal usability of the system.

The guidance requirements of a modern combat aircraft have been detailed here. The guidance system of the fighter aircraft has also been looked upon as a pilot-in-loop system and its implications examined. The author also explains how to mechanise the guidance functions so that one leverages a very effective pilot-vehicle interface, which is crucial

to mission performance of the aircraft. Also, top-level design of the guidance system and some characteristic values for the design parameters have been provided.

## 2. GUIDANCE REQUIREMENTS OF A MODERN FIGHTER AIRCRAFT

Various phases of mission need to be analysed for arriving at a complete set of requirements for guidance functions. These are taxiing phase, takeoff phase, flight phase, the approach and landing phase, the autopilot-coupled weapon delivery function, and the piloted weapon delivery function.

### 2.1 Guidance Requirements—Taxiing Phase

During the taxiing phase, the aircraft accelerates and acquires the required attitude and velocity for takeoff. Hence, a way is needed to present this information to the pilot. The aircraft longitudinal acceleration also needs to be displayed during this phase since the aircraft needs to accelerate more than a minimum value.

### 2.2 Guidance Requirements—Takeoff Phase

One needs to represent the potential slope of the aircraft during takeoff, which is a direct indication of the climb capacity of the aircraft. Some amount of persistence of the information presented to the pilot is required, which means that some of the reticles displayed need to be present on the display surface for some time even after the aircraft takes off.

### 2.3 Guidance Requirements—Flight Phase

During the flight phase, the aircraft executes a mission profile, which involves flying a course defined by a flight plan. The system usually stores multiple flight plans. A flight plan consists of a number of waypoints. These waypoints may be associated with offsets, desired time-of-arrival or delta time, altitude, and desired track. Navigating a flight plan involves choosing a flight plan and appropriately steering the aircraft in accordance with that plan. This necessitates the use of different functions depending on the relative position of the aircraft vis-à-vis the flight plan. This is shown in

Fig. 1. Following are the guidance requirements during the various subphases of the flight phase:

#### 2.3.1 Subphase 1: Cruise Phase

The cruise phase is the portion of the flight segment extending from a waypoint  $n$  to the next waypoint  $n + 1$  such that this segment does not enter the rendezvous region (circle) around the waypoint  $n + 1$ . The pilot requires guidance from the system to either accelerate or decelerate the aircraft (speed guidance) to reach the waypoint  $n + 1$  at the previously inserted time-of-arrival. Also, if a complete flight plan was being navigated, then the pilot would require the system to automatically sequence the waypoints in the flight plan (automatic navigation).

#### 2.3.2 Subphase 2: Rendezvous Phase

The rendezvous phase is the portion of the flight segment extending across the diameter of a circle defined around the waypoint  $n + 1$  to which the aircraft is navigating. During this subphase, the pilot requires precision guidance to reach the steerpoint (homing guidance or desired track guidance). The guidance required is primarily the bank angle to be applied to the aircraft.

#### 2.3.3 Subphase 3: Terminal Phase

The terminal phase is the portion of the flight segment extending across the diameter of a circle defined around the last waypoint in the flight plan. During this last subphase, the pilot requires guidance to approach the runway and land the aircraft. Two crucial guidance parameters are the slope of descent guidance and the desired angle of attack guidance. The pilot also needs information regarding the control tower radio and radar communication frequencies, runway heading and lengths, once he is in the vicinity of the airfield.

## 3. GUIDANCE FUNCTION AS A PILOT-IN-LOOP SYSTEM

Converting guidance functional requirements to an effective and robust design requires one to

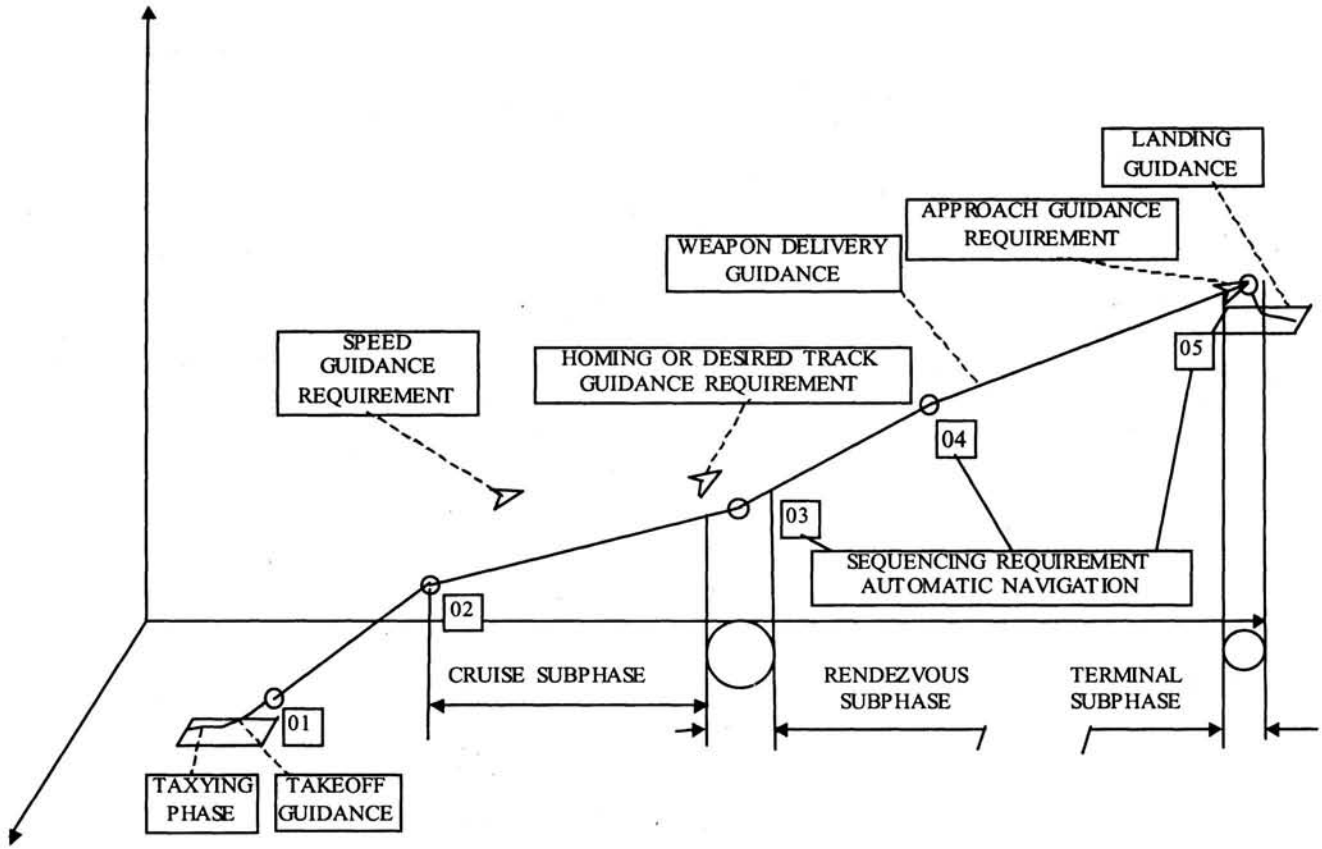

Figure 1. A flight plan with phases and subphases of flight

view the system as a closed-loop control system. Figure 2 provides an understanding of the variables involved in providing such a system. The guidance laws computational block receives reference input from the mission trajectories and control-strategy system block. These reference input are the

predefined navigational parametric data (like heading of a waypoint, maximum aircraft speed, etc). The reference input are compared with the actual flight parameters, which are obtained from the flight parameters sensor system block. For example, in the case of speed guidance, the reference

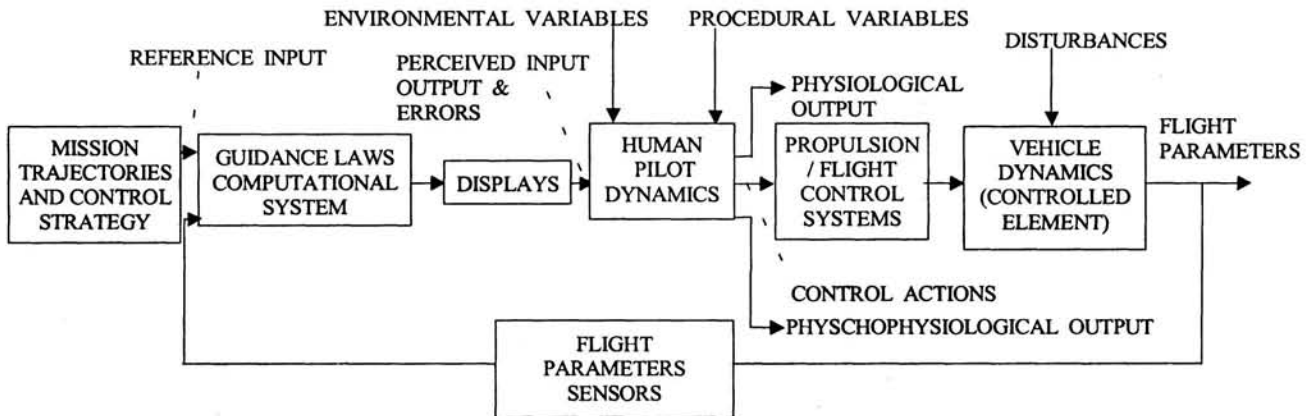

Figure 2. Block diagram of aircraft guidance system

input is the desired speed (control-strategy profile) and the compared input is the aircraft present speed. The difference between these two input is the error signal which drives the generation of the suitable display cues. The placement of the display cues relative to each other indicates the error. To avoid the jitter of the guidance symbols on the display surfaces, the error is processed through low-pass filters, designed considering acceptable time lags. Compensations due to data latency of the parameters used in computing the errors and also due to pilot dynamics are considered. The pilot being presented a visual indication of the error of a particular flight parameter, tries to correct the error by providing suitable input to the propulsion and flight control system. In case of speed guidance, the throttle input to the propulsion system adjusts the aircraft acceleration (controlled parameter) to achieve the desired speed. The propulsion/flight control system translates the input to actual physical input (surface/component deflections) to obtain the desired physical response.

#### 4. GUIDANCE SYSTEM MECHANISATION

##### 4.1 Mechanising Takeoff Mode Reticles

The required takeoff attitude is represented by an inverted T set below the fuselage reference line (FRL) on the heads-up-display. The takeoff attitude is attained when the horizon bar coincides with this symbol. The aircraft longitudinal acceleration is displayed as a counter on the heads-up-display. The vertical displacement of the velocity vector from the energy markers represents the potential slope of the aircraft and gives an indication of the climb capacity of the aircraft. Figure 3 shows the takeoff guidance reticles on the heads-up-display. The energy markers can be modulated by varying the throttle, and hence, engine thrust.

##### 4.2 Mechanising Speed Guidance Reticles

The speed guidance is provided by speed guidance brackets on heads-up-display, representing the flight-path acceleration rate to be taken to reach the waypoint at the desired time associated with the waypoint. Two counters are also provided one giving the commanded ground speed and the other providing

the present ground speed. The speed guidance brackets move along the heads-up-display vertical axis, centred on the velocity vector, and displacement between the energy markers and the speed guidance brackets represents the difference between the commanded ground speed and the present ground speed. When the speed guidance cannot be provided due to exceedance of maximum speed of the aircraft, recomputation of delta times associated with waypoints on the remaining flight legs is possible if the pilot makes an explicit request for this. A warning indication is provided on the display surfaces during such a situation. Figure 4 shows the speed guidance reticles on the heads-up-display.

##### 4.3 Mechanising Homing Guidance Reticles

The homing guidance reticles provide guidance to the pilot to reach the steerpoint along the direct track. This guidance is provided by the HUT reticle (when the distance to steerpoint is more than 20 km) or the waypoint cross reticle (when the distance to steerpoint is  $\leq 20$  km) on the heads-up-display and track error bug reticle on the MFDs. The X-component of the waypoint cross reticle or the HUT reticle represents relative bearing and the Y-component represents the dip angle. Figure 5 shows the realisation of the homing guidance reticles.

##### 4.4 Mechanising Approach Guidance Reticles

Landing of the aircraft is accomplished by acquiring the desired slope to the runway at the desired angle of attack. Two reticles are provided. The first is the slope guidance brackets which consist of a bar broken in the middle and positioned below the horizon bar and parallel to it. Displacement of the reticle from the horizon bar indicates the desired slope at a scale of 1:1. The second is the angle of attack guidance brackets which consist of a pair of square brackets, positioned relative to the velocity vector and always parallel to the base of the heads-up-display. The brackets move in the vertical plane and the displacement of these brackets from the velocity vector is equal to the difference between the aircraft angle of attack and the desired angle of attack. Figure 6 shows the approach guidance reticles.

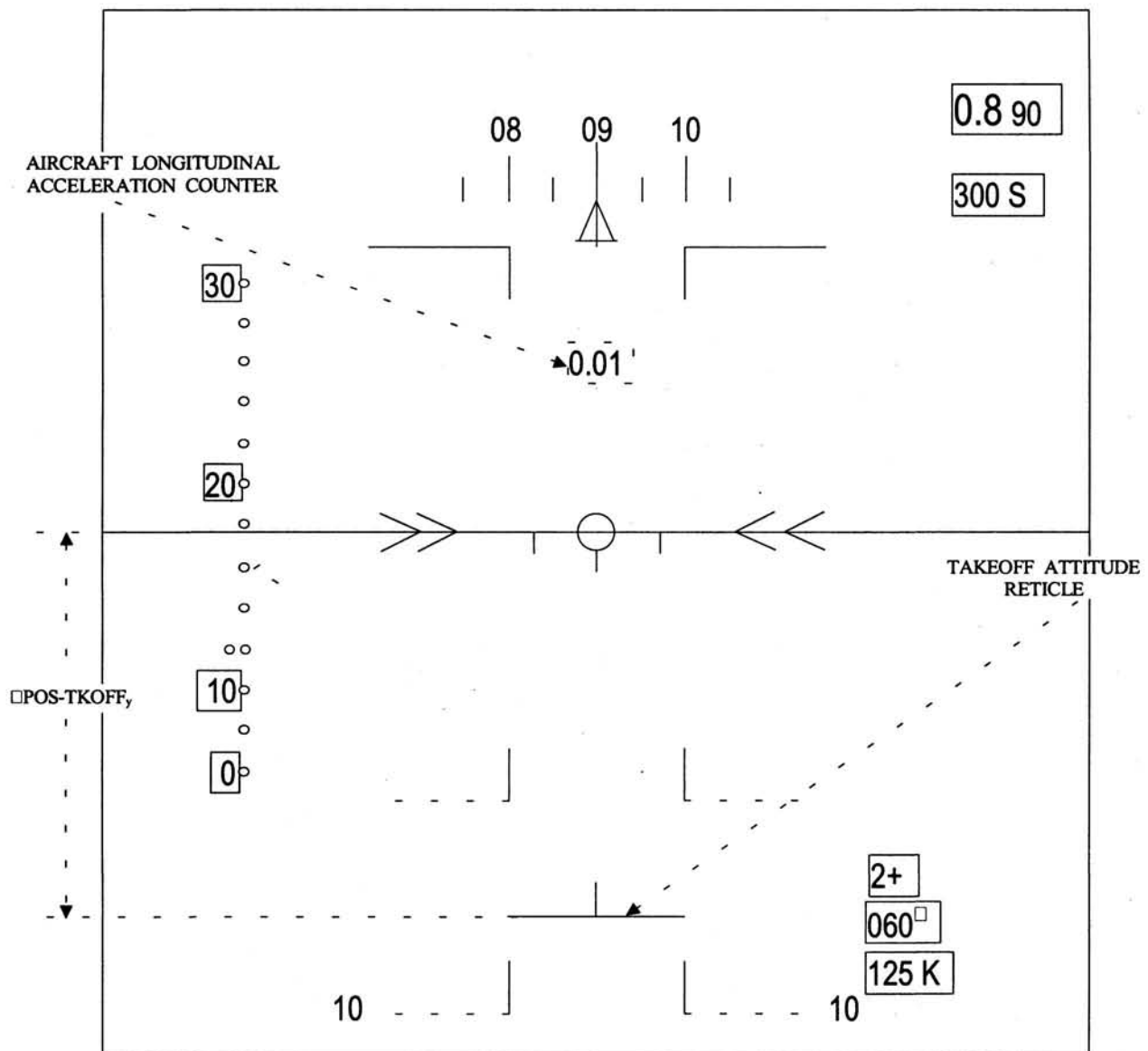

Figure 3. Takeoff guidance reticles on the heads-up-display

## 5. DESIGN OF GUIDANCE SYSTEM

### 5.1 General Philosophy

The design of the guidance system involves finding a suitable transfer function for the guidance law in focus. This involves arriving at the system transfer function considering all the elements involved in such a system. The design of the guidance system involves the following:

- Modelling the plant dynamics
- Modelling the pilot dynamics
- Modelling the sensor systems
- Modelling the computational delays and data latencies
- Specifying the parameters of performance like speed of response, overshoots, steady state errors, etc



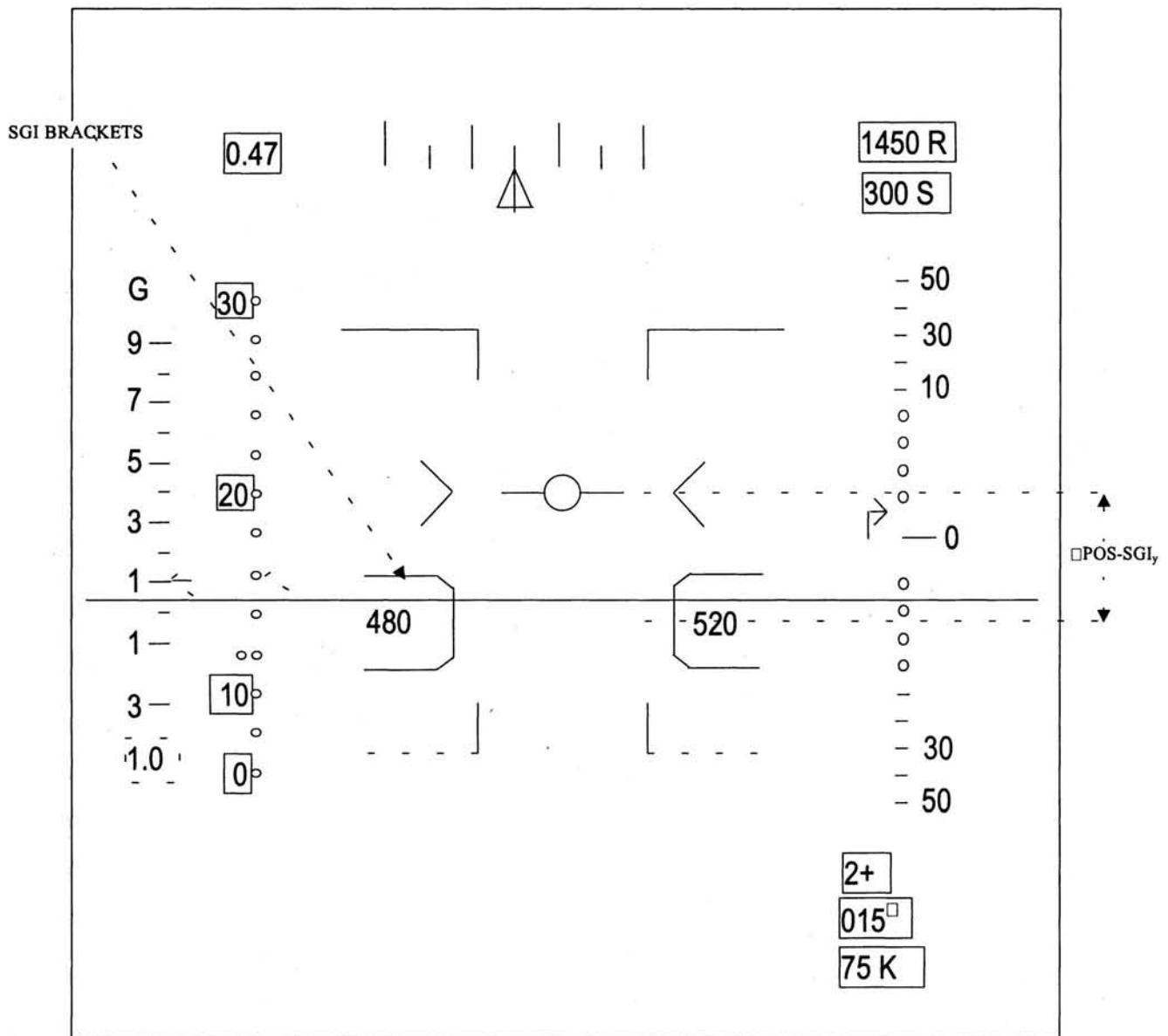

Figure 4. Speed guidance reticles on the heads-up-display

- Evolving a suitable structure of the guidance controller
  - Preparing analytical design of the guidance controller using linear methods
  - Simulation and tuning of the guidance controller using nonlinear models
  - Evaluating the guidance controller and fine tuning using pilot-in-loop simulators
  - Final tuning of the controller based on the flight trial data.
- The structure of the guidance controller provides for proportional, derivative, and integral terms. It also incorporates nonlinear gains and limiters.
- The reference angle of attack for takeoff depends on the takeoff weight, winds conditions, and atmospheric conditions. The symbology includes energy markers indicating the potential slope

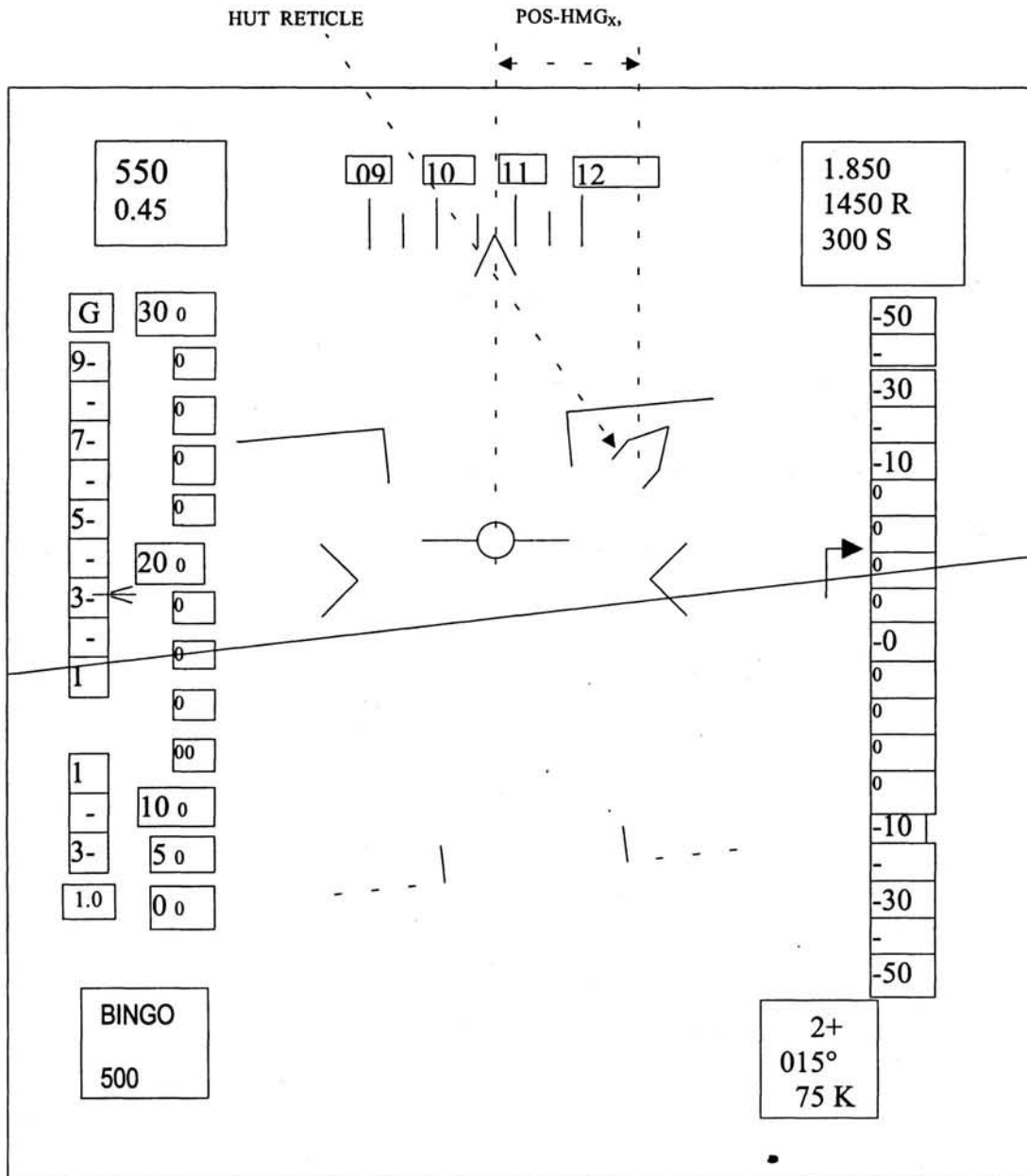

Figure 5. Homing guidance reticles

and forward acceleration. Figure 7 shows the feedback control loop for takeoff guidance. The transfer function for the whole system takes the form:

$$Y(s) / R(s) = K_1 G_{TKOFF}(s) G_p(s) / [1 + (K_1 G_{TKOFF}(s) G_p(s) G_s(s))]$$

The guidance involves designing  $K_1 G_{TKOFF}(s)$  to meet the system performance requirements. The design helps provide a value for the parameter  $K_{TKOFF}$  such that  $\Delta POS-TKOFF_y = K_{TKOFF} \psi_{AATT}$ .  $\Delta POS-TKOFF_y$  translates to the displacement of the takeoff guidance reticles from the horizon bar on the heads-up-display, as shown in Fig. 3.

AOA GUIDANCE BRACKETS

SLOPE GUIDANCE RETICLE

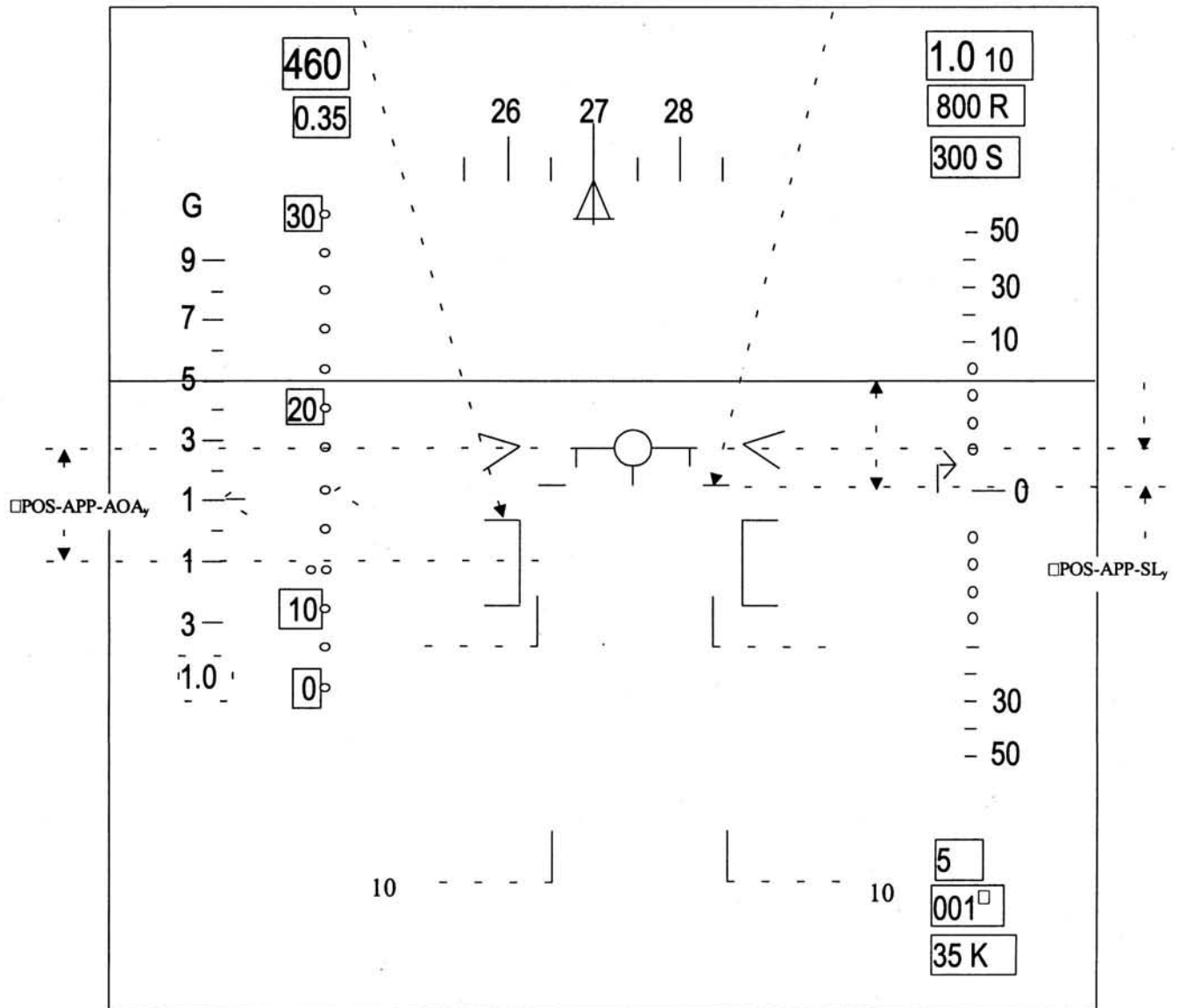

Figure 6. Approach guidance reticles

Initially, the designing is done in linear domain. Later, it is fine-tuned by incorporating nonlinearities in the controller and the plant sensors using simulation and analysis.

Figure 8 shows the feedback control loop for the speed guidance. The transfer function for the whole system takes the form:

$$Y(s) / R(s) = K_2 G_{SGI}(s) G_p(s) / [1 + (K_2 G_{SGI}(s) G_p(s) G_s(s))]$$

The guidance involves designing  $K_2 G_{SGI}(s)$  to meet the system performance requirements.

The designing helps provide a value for the parameter  $K_{SGI}$  such that  $\Delta POS-SGI_y = K_{SGI} V_{ds}$ .



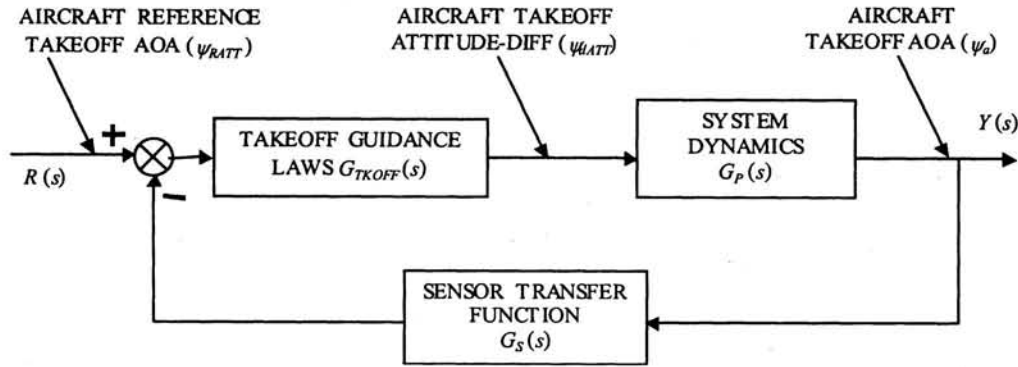

Figure 7. Feedback control loop for takeoff guidance function

$\Delta$ POS-SGI<sub>y</sub> translates to the displacement of the speed guidance reticles from the velocity vector on the heads-up-display, as shown in Fig. 4, which shows the aircraft flying at more than the required speed to reach the destination waypoint at the desired time. Initially, the designing is done in linear domain. Later, it is fine-tuned by incorporating nonlinearities in the controller and plant sensors using simulation and analysis.

5.2 Design for Homing Guidance

Figure 9 shows the feedback control loop for homing guidance. The transfer function for the whole system takes the form:

$$Y(s) / R(s) = K_3 G_{HMG}(s) G_p(s) / [1 + (K_3 G_{HMG}(s) G_p(s) G_s(s))]$$

The homing guidance involves designing  $K_3 G_{HMG}(s)$  to meet the system performance requirements.

The designing helps provide a value for the parameter  $K_{HMG}$  such that  $\Delta$ POS-HMG<sub>x</sub> =  $K_{HMG} \cdot \epsilon_{TKE}$  translates to the displacement of the HUT reticle from the velocity vector on the heads-up-display, as shown in Fig 5. This figure shows the aircraft flying with a track error less than a specified value and positioned to the left of the waypoint (relative to the waypoint). The direction of the HUT reticle indicates the direction in which to turn. Initially, the designing is done in linear domain. Later, it is fine-tuned by incorporating nonlinearities in the controller and plant sensors using simulation and analysis.

5.3 Design for the Approach Guidance

5.3.1 Slope Guidance

Figure 10 shows the feedback control loop for slope guidance. The transfer function for the whole system takes the form:

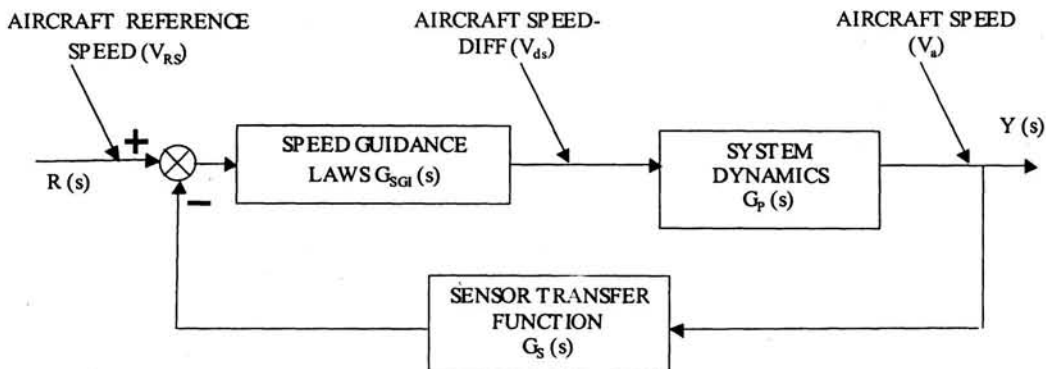

Figure 8. Feedback control loop for speed guidance function

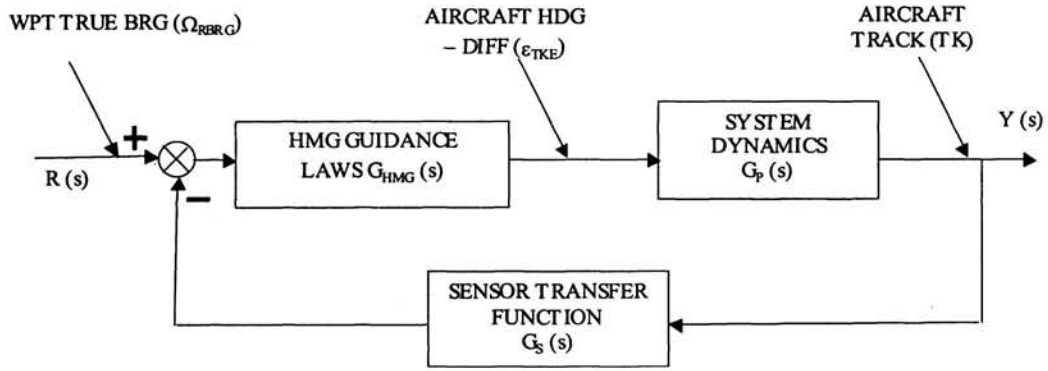

Figure 9. Feedback control loop for homing guidance function

$$Y(s) / R(s) = K_4 G_{SL}(s) G_p(s) / [1 + (K_4 G_{SL}(s) G_p(s) G_s(s))]$$

Guidance involves designing  $K_4 G_{SL}(s)$  to meet the system performance requirements.

The designing helps provide a value for the parameter  $K_{SL}$  such that  $\Delta POS-APP-SL_y = K_{SL} \lambda_{dSL}$  translates to displacement of the slope bar (broken bar) from the velocity vector.

This figure shows the aircraft flying with a slope that is different from the desired slope of descent (indicated by the vertical displacement of the slope bar from the velocity vector). The displacement gives the relative amount of flight control system input to be given to bring the aircraft along the desired slope of descent. The desired slope represented by the broken bar is always fixed wrt the horizon bar. Initially, the designing is done in linear domain.

Later, it is fine-tuned by incorporating nonlinearities in the controller and plant sensors using simulation and analysis.

Figure 11 shows the feedback control loop for angle of attack guidance. The transfer function for the whole system takes the form:

$$Y(s)/R(s) = K_5 G_{AOA}(s) G_p(s) / [1 + (K_5 G_{AOA}(s) G_p(s) G_s(s))]$$

Guidance involves designing  $K_5 G_{AOA}(s)$  to meet the system performance requirements.

The designing helps provide a value for the parameter  $K_{AOA}$  such that  $\Delta POS-APP-AOA_y = K_{AOA} \alpha_{dAOA}$  translates to displacement of the angle of attack guidance brackets from the velocity vector. The displacement represents the difference between the desired angle of attack and the

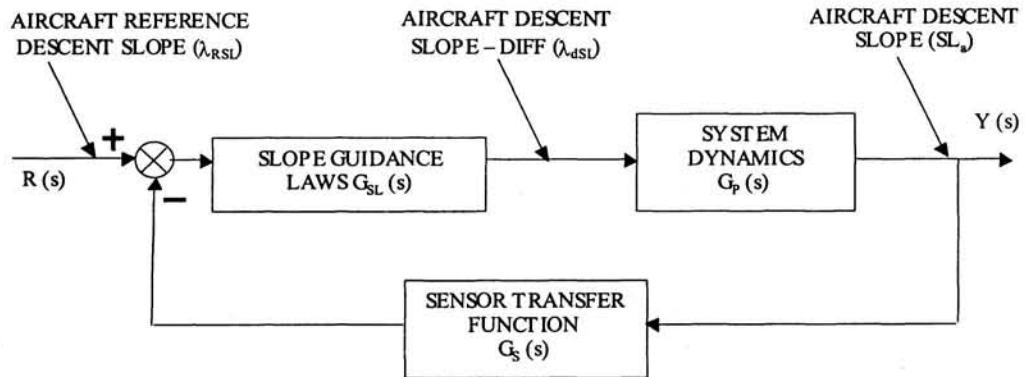

Figure 10. Feedback control loop for slope guidance function

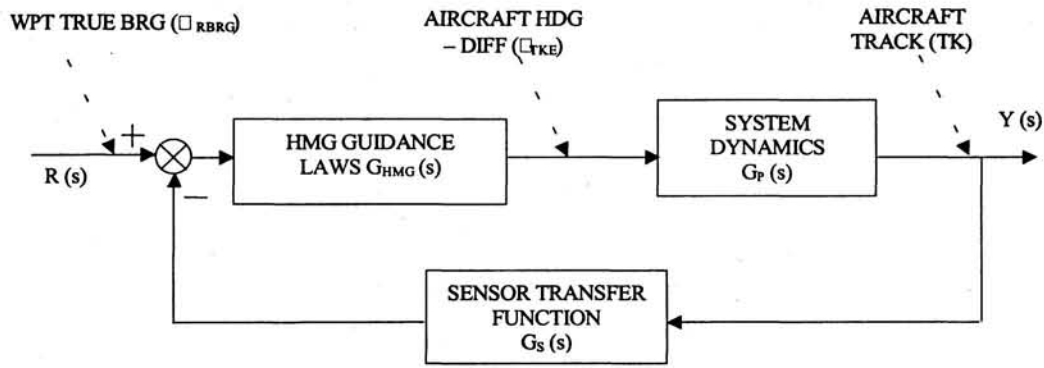

Figure 11. Feedback control loop for angle of attack guidance function

actual angle of attack. The figure shows the aircraft flying with an angle of attack less than the desired angle of attack. The displacement is an indication to the pilot to apply the necessary commands to bring the aircraft angle of attack to the desired angle of attack. Initially, the designing is done in linear domain. Later, it is fine-tuned by incorporating nonlinearities in the controller and plant sensors using simulation and analysis.

**5.4 Design for Automatic Navigation Guidance**

The automatic navigation guidance block switches the steer point in accordance to a predefined rule. A predefined rule (example) may be that distance to a steerpoint which shows an increasing trend, and the steerpoint is within a proximity sphere (predefined radius).

Figure 12 shows the feedback control loop for automatic navigation guidance. The transfer function for the whole system takes the form:

$$Y(s)/R(s) = K_6 G_{AUT}(s) G_p(s) / [1 + (K_6 G_{AUT}(s) G_p(s) G_s(s))]$$

The guidance involves designing  $K_6 G_{AUT}(s)$  to meet the system performance requirements.

The designing helps provide a value for the parameter  $K_{AUT}$  such that switching condition is met when  $K_{AUT} SPP_a = SP_{Threshold}$ . Initially, the design is done in linear domain. Later, it is fine-tuned by incorporating nonlinearities in the controller and plant sensors, using simulation and analysis.

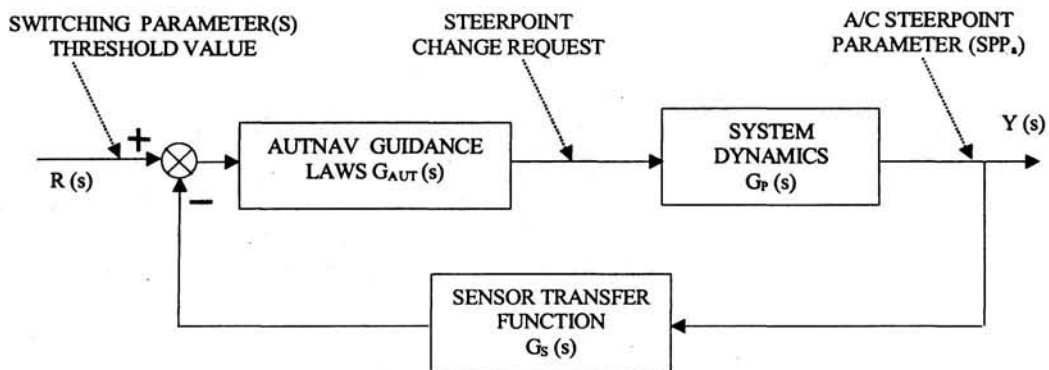

Figure 12. Feedback control loop for automatic navigation guidance

Table 1. Design parametric values for guidance functions

Guidance function	Parameter	Surface	
		HUD	MFD
Takeoff guidance	$K_{TKOFF}$	1.50	2.75
	$UT_{TKOFF}$	160 ms	160 ms
	$T_{s-TKOFF}$	80 ms	80 ms
	$TC_{TKOFF}$	20–40 ms	20–40 ms
Speed guidance	$K_{SGI}$	1.50	2.75
	$UT_{SGI}$	160 ms	160 ms
	$T_{s-SGI}$	100 ms	100 ms
	$TC_{SGI}$	50–100 ms	50–100 ms
Homing guidance	$K_{HMG}$	1.50	2.75
	$UT_{HMG}$	160 ms	160 ms
	$T_{s-HMG}$	80 ms	80 ms
	$TC_{HMG}$	20–40 ms	20–40 ms
Approach slope guidance	$K_{SL}$	1.50	2.75
	$UT_{SL}$	160 ms	160 ms
	$T_{s-SL}$	100 ms	100 ms
	$TC_{SL}$	50–100 ms	50–100 ms
Approach AOA guidance	$K_{AOA}$	1.50	2.75
	$UT_{AOA}$	160 ms	160 ms
	$T_{s-AOA}$	80 ms	80 ms
	$TC_{AOA}$	20–40 ms	20–40 ms
Automatic navigation guidance	$K_{AUT}$	1.50	2.75
	$UT_{AUT}$	160 ms	160 ms
	$T_{s-AUT}$	160 ms	160 ms
	$TC_{AUT}$	100–250 ms	100–250 ms

## 6. DESIGN PARAMETERIC VALUES FOR THE GUIDANCE SYSTEM

The coefficients  $K_{TKOFF} [= K_1 G_{TKOFF}(s)]$  for takeoff guidance,  $K_{SGI} [= K_2 G_{SGI}(s)]$  for speed guidance,  $K_{HMG} [= K_3 G_{HMG}(s)]$  for homing guidance,  $K_{SL} [= K_4 G_{SL}(s)]$  for approach slope guidance,  $K_{AOA} [= K_5 G_{AOA}(s)]$  for approach angle of attack guidance, and  $K_{AUT} [= K_6 G_{AUT}(s)]$  for automatic navigation guidance are the important design parameters. The values for these coefficients are different for different display surfaces and these are listed in Table 1.

The update time of these guidance functions is related to the settling time ( $T_s$ ) and forms another important component in the design of these guidance laws. A design goal of the 160 ms is chosen for the update time. The settling time is dependent on the undamped loop natural frequency ( $\omega_n$ ) and damping

ratio ( $\zeta$ ). The time constant for these guidance functions also forms an important design parameter. The characteristic values for the typical guidance functions are listed in Table 1.

## 7. CONCLUSION

This paper presents the guidance needs of a modern fighter aircraft and shows how to translate those requirements into the specific functions within the overall mission profile of the fighter aircraft. Effective mechanisation of these functions is achieved by viewing these functions as part of a feedback control loop system. The guidance function response is characterised with a transfer function that is suitably designed to meet the system performance requirements. The guidance law transfer functions may be realised using an appropriate algorithm in software during implementation. The characteristics values for the design parameters are also given.

This paper also presents how various guidance functions are mechanised with intuitive display cues, which indicate the relative error between the desired response and the fighter aircraft response of a particular navigational parameter. Thus, the paper

presents a method to move away from a design based on heuristics to one providing a concrete foundation based on control system engineering approach.

### Contributors

**Mr K.N. Rajanikanth** obtained his BE (Elec) from the BMS College of Engineering, Bangalore, in 1991 and MSc (Engg), in Computer Science from the Indian Institute of Science (IISc), Bangalore, in 2003. He worked with the Bharat Electronics in Military Communication Group and Wipro Systems (AT&T GTE Communication Systems) prior to joining the Aeronautical Development Agency (ADA), Bangalore. He is currently Scientist D and works for the Mission Software Group as Design Team Leader. His current research interests include: Real-time systems, object technology, software architecture and design issues for real-time systems, and simulation.

**Mr R.S. Rao** obtained his BE (Elec) from the Andhra University; subsequently joined Hindustan Aeronautics Ltd Aircraft Design Bureau as Design Trainee and had PG course at the Indian Institute of Technology Kanpur as part of institutional training. He held positions of Aero Engineer, Dy Design Engineer, and Design Engineer at the HAL and worked on the *Ajeet*, *Kiran*, *Jaguar*, MiG series aircraft in the areas of avionics and weapon system. Subsequently, he joined ADA, Bangalore, as Scientist D. He is currently the Group Director, who is responsible for weapon integration and mission management systems.

**Mr P.S. Subramanyam** completed his BE (Mech) from the Regional Engineering College, Warangal, Osmania University and ME (Aero) with specialisation in flight control systems from the IISc, Bangalore. During 1975–86, he worked at the Defence Research & Development Laboratory and was responsible for design, development of control, guidance and navigation systems of missiles. He worked specially on the hardware-in-the loop simulations and testing of the flight systems in a real-time environment and also developed and tested the onboard computer software. Presently, he is Associate Programme Director (LCA), and Project Director (Independent Flight Control Systems and Avionic Systems) at the ADA, Bangalore. He has been working since 1986. He worked on LCA avionics systems, encompassing areas like mathematical modelling of LCA sensors-radar, INS, GPS, etc; development of prototyping facilities for avionic systems, cockpit environment facility for evaluation of pilot-vehicle interface; design of algorithms, functions for weapon delivery; and also hardware-in-the-loop testing of LCA avionic systems. He has been responsible for the design, development, testing and airworthiness certification of integrated flight control system, digital avionic system, and weapon system of the LCA.