

Defence Science Journal, Vol. 56, No. 4, October 2006, pp. 615-626
© 2006, DESIDOC

REVIEW PAPER

Piezo-actuated Vibration and Flutter Control

S.B. Kandagal and Kartik Venkatraman
Indian Institute of Science, Bangalore-560 012

ABSTRACT

The potential application of smart materials is being investigated by various researchers in the perspective of building intelligent systems. A smart structure consists of distributed actuators and sensors with associated processors to analyse and control the structure. Piezoceramics, magnetostrictive materials, electro-rheological fluids, magneto-rheological fluids, shape memory alloys, fibre optics are quite often used in realising a smart/intelligent system. In this paper, vibration and flutter control using piezoceramics is reviewed. Various aspects covering relative merits of piezoceramics with other smart materials and application capabilities are discussed.

Keywords: Vibration, flutter control, actuators, sensors, smart materials, piezoceramics, passive damping, magnetostrictive materials, electro-rheological fluids, magneto-rheological fluids, aero-mechanical systems, electrostrictive materials, shape memory alloys

1. INTRODUCTION

Control of vibration and flutter plays an important role in the satisfactory performance of many aero-mechanical systems such as aircraft wings, helicopter rotors, propellers of a turbo-prop engines, or compressor and rotors of jet engines. With advances in active materials, it has become possible to integrate sensing, actuation, and control of vibration and flutter intrinsically in the design of the structure.

Piezoceramics, magnetostrictive materials, electrostrictive materials, shape memory alloys, electro-rheological and magneto-rheological fluids, are families of active materials that are potentially being considered for use. These materials are essentially transformers that convert electrical or electromagnetic energy into mechanical energy and *vice versa*.

2. REVIEW OF SMART MATERIALS

The increasing demands on the performance of structural systems for aeronautical and astronautical applications require a new class of structural systems. So called smart/adaptive/intelligent structures are an evolution from the composite structural materials. Crawley,¹ Tani,² Sunar and Rao³ have discussed smart materials in the context of their potential applications and have suggested a road map for the future using such materials with integrated signal processing and control electronics. Newnham and Ruschu⁴ have carried out a comparative study of various smart materials to mimic the biological phenomena with the help of piezoceramics, shape memory alloys, and electro-rheological fluids. Loewy⁵ and Garg⁶ have also summarised the potential application of active materials in aircraft performance and handling, in general, as well as more specifically, in control of aeroelastic instabilities such as flutter,

divergence, and aircraft vibration. A review on the state-of-the-art of smart systems with emphasis on rotorcraft has been given by Chopra⁷ and on composite structure by Durr⁸.

3. INTELLIGENT STRUCTURES

The intelligent structures are those which incorporate actuators and sensors that are highly integrated into the structure and have structural functionality as well as control logic, signal conditioning, and power amplification electronics. Crawley¹ and Tani² presented smart structure as a subset of broader categories as shown in Fig. 1. Intelligent structures are subset of a larger domain, that have actuators distributed throughout. An active structure would have highly distributed sensors and actuators that are active part of the structure. In addition, the smart structures should also have control functions distributed throughout it.

3.1 Piezoelectric Actuators

The actuator materials are typically employed to dynamically tune the global mechanical properties of the structure in a systematic manner. The parameters that determine the characteristics of good actuators are—maximum achievable strain, maximum block force it can generate, stiffness, bandwidth, linearity, density, embedability, compactness, efficiency, and sensitivity to temperature and other environmental

conditions. Spillman⁹ has discussed in detail about sensing and processing of smart structures.

The strain induced by an actuator is called its actuation strain. These actuation strains can be generated in various ways, such as piezoelectricity, magnetostriction, and shape memory effects. Among the available actuators, piezoceramics, magnetostrictive materials, and shape memory alloys are the most commonly used due to their properties. A comparison of properties of these materials^{1,2,10} is shown in Tables 1 and 2. Piezoelectric actuators are among the most common of all actuators used in smart materials since these serve both as sensor and actuator. Strain is induced locally into the structure by this effect which generates forces and moments.

Piezoelectric materials generally used in smart structures are available in two forms, ie, piezoceramics and piezoelectric polymers. The piezo's ability to actuate the structure is a function of its stiffness, electromechanical coupling coefficient, flexibility and limits on applied voltage. Piezoceramics such as lead-zirconate-titanate (PZT) are much stiffer and have larger mechanical coupling coefficients, hence are best suited as actuators. Polyvinylidene fluoride (PVDF) is good for sensing. Commonly used piezoceramic materials are lead magnesium niobate (PMN), lead zirconate titanate (PZT), and polyvinylidene fluoride (PVDF). Piezoceramics have a maximum actuation strain of the order of 1000

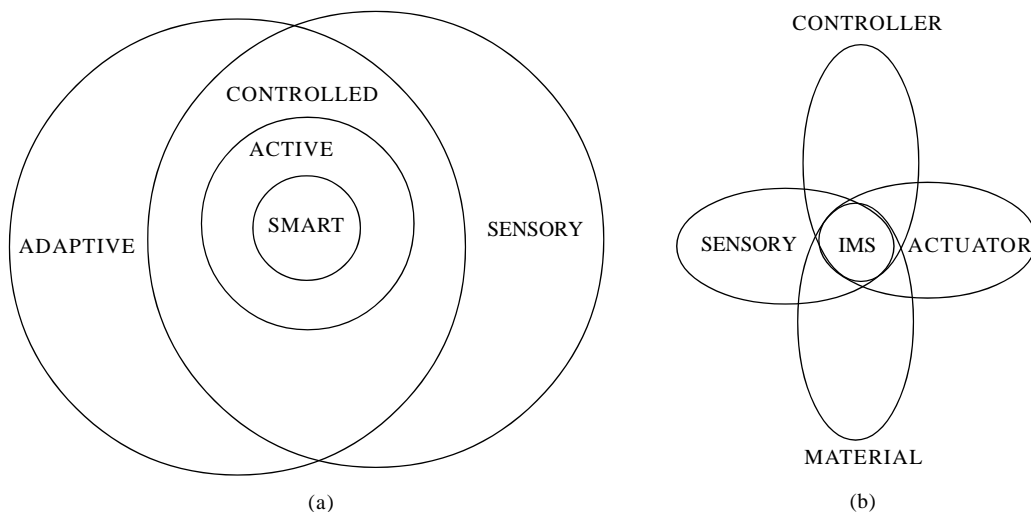

Figure 1. Concept of: (a) smart material and (b) intelligent material.

Table 1. Comparison of the actuation potential of smart materials^{1, 2, 10}

Properties	PZT	Terfenol-D	Nitinol
Actuation	Piezoceramics	Magnetostrictive	SMA
Mechanism	Voltage-strain	Current-strain	Temperature-strain
Maximum free induced strain (microstrain)	1000	2000	20000
Induced strain (microstrain)	350	580	8500
Density (kg/m ³)	7500	9250	7100
Young's modulus (GPa)	60.6	29.7	75 (high temp) 28 (low temp)
Frequency bandwidth	0.1Hz–GHz	0.1Hz–MHz	0.1–10 Hz
Work (J/cm ²)	0.035	0.080	10.000
Power (W/cm ²)	175	160	30
Maximum strain rate (s ⁻¹)	10	4	0.3
Maximum temperature (°C)	300	400	300
Strain-voltage	I order linear	Nonlinear	Nonlinear
Embedability	Excellent	Good	Excellent

Table 2. Comparison of PZT, PVDF and aluminum

Properties	PZT	PVDF	Aluminum
Density (kg/m ³)	7600	1800	2630
Young's modulus (GPa)	63	2	73
Poisson's ratio	0.29	0.3	0.3
Piezoelectric constant d ₃₁ (10 ⁻¹¹) m/V	37	2.2	-

microstrain, whereas PVDF achieves an actuation strain of 700 microstrain.

3.2 Piezoelectric Sensors

In a smart structure, the performance and functioning of an actuator is primarily dependent on the output of the sensor. Sensors convert strain or displacement into electric field. Similar to actuators, key parameters for sensors are sensitivity, bandwidth, density, temperature sensitivity, hysteresis, embedability, linearity, and associated electronics. Typical sensors are foil strain gauges, semiconductor strain gauges, accelerometers, various types of fibre optic strain sensors, piezoceramics, and polyvinylidene fluoride.

A comparison of important parameters of various sensors is given in Table 3.

3.3 Material Fabrication

The manufacture of commercial piezoceramic materials involves exposing the material to high temperature while imposing a high electric field intensity in a desired direction to create the piezoelectric properties. This is termed as poling. It is isotropic because of the random orientation of the dipoles. Upon developing a poling voltage in the direction of the poling axis as shown in Fig. 2, the dipoles reorient themselves, and for this condition, the structure undergoes deformation.

3.4 Industrial Configurations of Piezoceramic Materials

Piezoelectric ceramics are available in several configurations. These are bimorph, unimorphs, and stacks. Bimorph consists of two piezoelectric patches bonded to each other or to each side of a shim. To operate an actuator as bimorph, voltage is applied

Table 3. Comparison of the strain sensors^{1,10}

Properties	Foil ^a	Semiconductor ^a	Fibre optic ^b	Piezofilm ^c	Piezoceramics ^c
Sensitivity	30 V/ e	1000 V/ e	10 ⁶ V/ e	10000 ^o / e	2x10 ⁴ V/ e
Localisation (mm)	0.2	0.75	< 1.00	< 1.00	< 1.00
Bandwidth	0.1 Hz–20 kHz	0.1 Hz–20 kHz	0.1 Hz–20 kHz	0.1 Hz–GHz	0.1 Hz–GHz
Embedability	Good	Good	Excellent	Excellent	Excellent

Foil: Semiconductor gauges^a, 10 V excitation; 1 mm - interferometric gauge length^b; 0.025 mm - sensor thickness^c

such that one element expands while the other contracts. This creates a controlled motion or actuation force. Bimorphs will also actuate with only one of the two layers activated, in which case it is termed as unimorph.

Stack consists of multiple layers of piezoceramic bonded together so that these are mechanically in series and electrically in parallel. The strain induced in each layer is then summed up to produce the overall induced strain of the stack. Piezo stacks are capable of microns of expansion, kiloNewtons (kN) of force, and have a response time in milliseconds. The temperature environment for piezoelectric stacks is limited to half their Curie temperature. Above this point, the polarisation of the material begins to breakdown.

3.5 Lead-Zirconate-Titane Versus Polyvinylidene Fluoride

As mentioned earlier, PZT and PVDF are commonly used in smart structure applications. The mechanical and electrical properties of these materials are listed in Table 2. Based on the properties of PZT and PVDF, the following observations are summarised:

- Piezoceramics are much stiffer and have larger mechanical coupling coefficients as compared to PVDF, thus making these suitable as actuators. The density of PVDF is one-third and stiffness of an order less than PZT. This feature makes PVDF material suitable for lightweight structures undergoing large dynamic deflections without

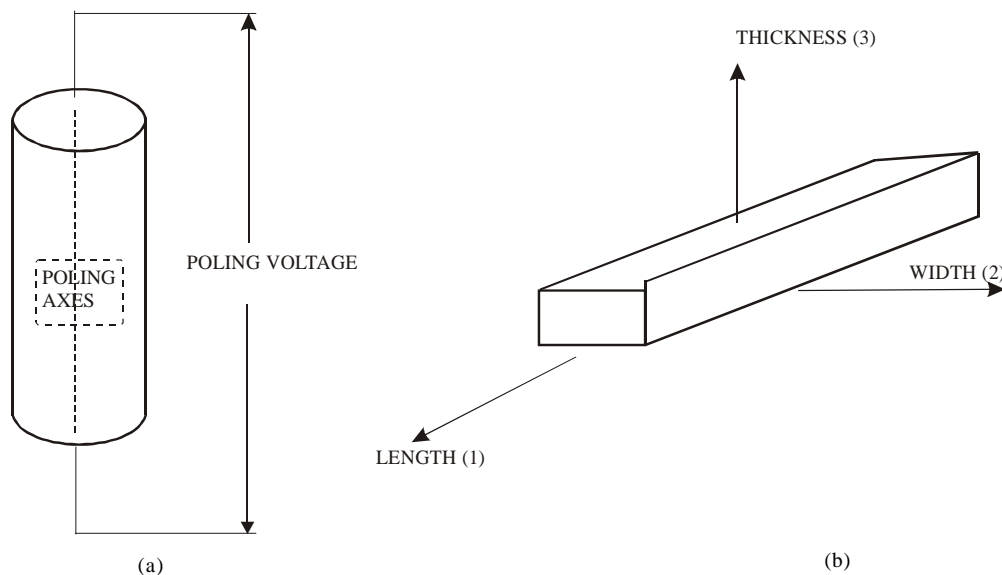

Figure 2. Concept of: (a) poling procedure of piezoceramics and (b) notation for poling vs deformation¹².

significantly distorting the electro-dynamic characteristics of the original structure. PVDF are temperature-sensitive, resulting in decreased performance with increase of temperature. A typical limiting temperature for PVDF applications is of the order of 100 °C, however piezoceramic elements are generally employed¹¹ in environments where the temperature is in the range -150 °C to 250 °C. PVDF films are extremely robust when subjected to diverse chemical environments with humidity, solvents, acids, and ultraviolet radiation.

3.6 Piezoceramic Application to Structures

Vibration and shape control of structures need the actuator patches, either directly bonded or

embedded in the structure. In these cases, relative stiffness of the actuator and the host structure, position of the actuator, orientation of patch, polarisation and the polarity of the applied excitation determine whether the induced loading is in pure bending moment or extensional, as shown in Figs 3 and 4. The bond between the piezoelectric material should be perfect and stiffness of the material should be greater than the substructure in order that the piezoelectric actuator material can generate relatively large strains in the host structure/substructure, and hence, modify the global response of the smart material in a systematic manner. Aluminum and PZT have this required property (Table 2) to utilise the efficiency of the PZT in most of the aeronautical applications.

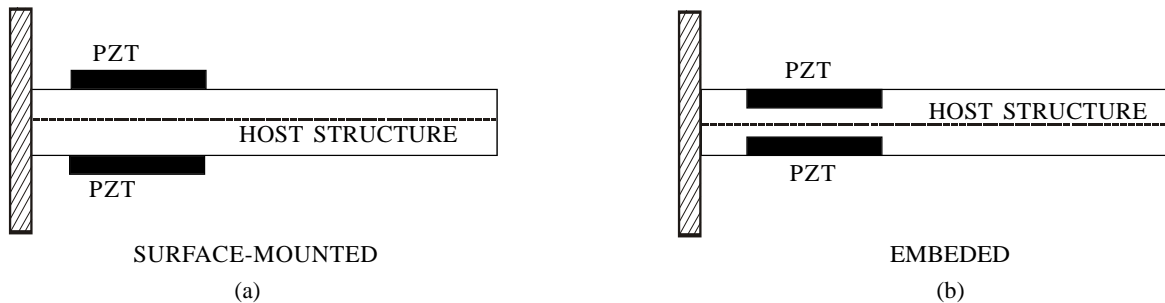

Figure 3. PZT with host structure: (a) surface mounted and (b) embedded.

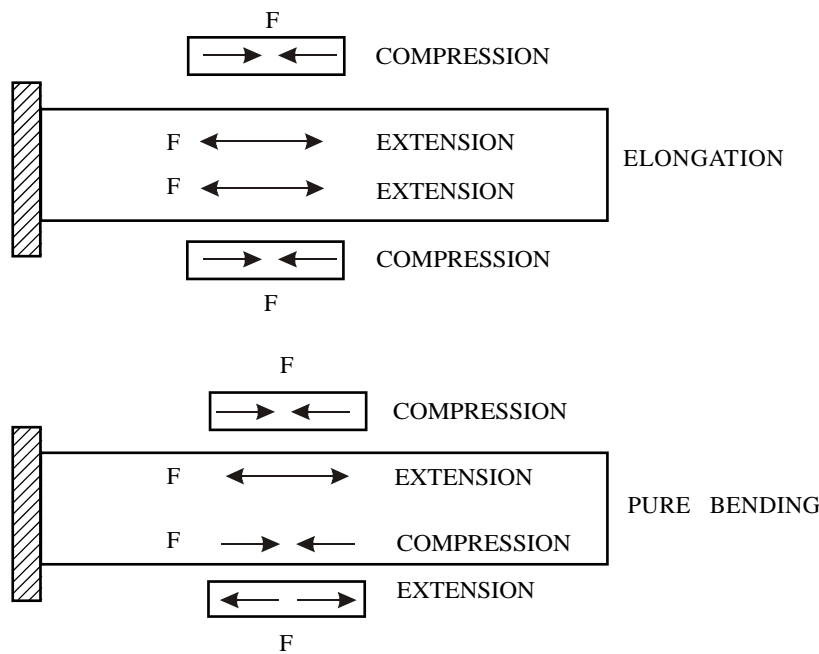

Figure 4. Simple block force model actuators on both surfaces.

In case of surface-bonded configurations, the deformation of the piezoceramics is constrained to match the deformations of the structure at contact surface, as shown in Fig. 3. Embedding the actuator allows the designer to place it exactly where he wants it, to get the desired effect, as shown in Fig. 3. The actuator is constrained to match the structure deformation at both the top and the bottom surfaces. Some problems with embedded piezoceramics arise, such as the curing temperature for composite materials has to be well below the Curie temperature of the piezoceramic, which is a serious limitation. Though embedded PZT helps these to protect these from the environmental variations, these are the potential sources of delamination.

3.7 Induced Strain Actuator Modelling

Some of the earliest models by Bailey¹³ and Crawley¹⁴ used the induced strain by the piezoelectric actuators as an applied strain that contributed to the total strain of the non-active structure, similar to thermal strain contribution. Analytical models involving one-dimensional beam-like structures were derived based on force equilibrium principles and Bernoulli-Euler beam theory. The popular analytical models that can be used, have been classified as: (i) static equivalent force model (ii) uniform strain model, (iii) consistent strain model or Bernoulli-Euler model (BEM), (iv) impedance approach model, and (v) finite element model.

3.8 Critical Parameters in Piezoceramic Performance

3.8.1 Hysteresis Effect

Hysteresis effects of the PZT are discussed by Sirohi and Chopra¹⁵. The hysteresis field-strain relationship of a piezoceramic for various levels of applied fields indicates that at higher fields, more hysteresis is observed. This hysteresis can be a major problem in positioning of PZT in various applications, as the hysteresis can be as high as 15 per cent of the full stroke of the actuator. However, in vibration problems, hysteresis can be considered as an unmodelled phase-lag and for static applications, hysteresis effect must be dealt explicitly.

3.8.2 Bonding Layer Effect

Different bonding techniques such as adhesive bonding, diffusion bonding, and metal bracing can be used to join piezoceramic actuators to metallic structures. Adhesive bonding is the most convenient method to bond actuators, since these may be cured at room temperature, and hence, have small residual stresses. A detailed study of the effect of bonding layer thickness was reported by Durr⁸. Bonding layer thickness up to 200 μ as found in common applications results in a moderate loss in efficiency of 11 per cent to 17 per cent. Another model, which is also based on static analysis, accounts for the effects of transverse shear and axial forces in addition to bending moment on the beam, was suggested by Im and Atluri¹⁶ to formulate the governing equilibrium equations. The shear stress distribution in both the top and bottom bonding layers was considered, with a possible application to un-symmetric-induced strains to the actuators bonded on one surface of the beam structure

3.8.3 External Loading Effect

Strains due to external loading or deformations, that are not caused by the actuation of the induced strain actuators themselves, can be included in the structure at the ends of the actuator. The pre-existing strains in the structure at the ends of the actuator must be known in advance. Chaudhry and Rogers¹⁷ presented an analysis of the effect of externally applied moments on a beam actuated out-of phase with various boundary conditions. It was shown that boundary conditions, which prevent the free actuation of the structure, have the same effect as external loading.

4. MECHANISMS OF VIBRATION CONTROL WITH STRAIN ACTUATION

Vibration can also be controlled using shunted piezoceramic materials as reported by Hagood¹⁸. Piezoelectric materials possess certain properties which make these useful as dampers or control elements for structures. The electrical energy generated by the piezoceramics during mechanical deformation can be effectively utilised to realise passive control by means of resistive, inductive, and capacitive

shunting or combinations among these. Indeed, shunting the electrical energy through a suitable resistive-inductive-capacitive (RLC) circuit is equivalent to controlling the vibration using a tuned mechanical absorber. Hagood and von Flotow¹⁹ have presented analytical and qualitative analyses of vibration reduction using resistive and inductive shunting. Lesieutre²⁰ reviewed vibration and damping control using piezoelectric material.

Shunted piezoelectrics exhibit certain advantages over alternative approaches that include design flexibility, relative insensitivity to temperature (compared to viscoelastic materials), and high effective loss modulus in resistive shunting applications. Once a piezoelectric element is incorporated in the structure with shunting, fine tuning can be accompanied by adjusting the values of discrete electrical components. Potential disadvantages using piezoelectric-shunted piezoelectric elements include relatively low tensile strain to failure (for piezoceramics), relatively high density, little data on fatigue properties. The concept of damping using shunted piezoceramics is also revalidated by Law²¹. Modal strain energy approach proposed by Davis²² was used to predict the added damping due to resistively shunted piezoceramics. Application of resistive shunting was experimentally demonstrated on a space structure by Hagood and Crawley²³. Steffen and Inman²⁴ gave a general methodology for the optimal design of piezoelectric materials for vibration damping in mechanical system when several natural frequencies are present in the frequency band of interest with active vibration control system and passive shunt technique.

Kandagal and Venkatraman²⁵ experimentally demonstrated the viscoelastic behaviour of shunted piezoceramics. The optimal thickness ratio (beam thickness/PZT thickness), which ensures maximum damping for a given length ratio of beam to PZT length, is invariant of the boundary conditions²⁶.

Sarvanos²⁷ has developed mechanics for the analysis of damping in composite plates with multiple resistively-shunted piezoelectric layers. Tang and Wang²⁸ utilised the resistive shunting of piezoceramics in vibration control of rotationally periodic structures. Aggenni²⁹ used shunted piezoelectric patches in elastic and aeroelastic vibration control.

4.1 Design of Controllers for Smart Structures

In an active (feedback) control, the strain developed is signal-conditioned and used for feedback control employing suitable control laws. The active control strategy for smart structure can be broadly classified as (a) state-space control and (b) distributed parameter control. In case of state-space control, the design of such controllers are based on pointed sensing and actuation. Tzou and Tseng³⁰ implemented two simple control algorithms: (a) constant gain feedback control and (b) constant amplitude feedback control on a model plate with piezoelectric sensor and actuator. Fanson and Caughey³¹ proposed the use of positive position feedback (PPF) control for large space structures. The same concept was later used by Denoyer and Kwak³² for vibration suppression of a slewing structure using piezoelectric sensor and actuator. Anderson and Hagood³³ used simultaneous piezoelectric sensing/actuation to successfully implement in an open-loop experiment with an active piezoelectric strut in a truss structure.

4.2 Placement of Sensor and Actuator

Location of sensor and actuator for vibration suppression is an important factor. The developments in this area has been extensively surveyed by Kubrusly and Malebranche³⁴. Lim³⁵ explained the method for optimal actuator and sensor placement in application to large flexible structures. Sunar and Rao³⁶ emphasised the location of piezoceramic patches in the place of high strain, by numerical simulation for a cantilever beam.

5. MECHANISM OF AEROELASTIC CONTROL WITH CONTROL SURFACE AND STRAIN ACTUATION

The advantage of strain actuation to control flutter over conventional methods lies in the fact that strain actuation can be used to actuate frequencies up to several KHz. Besides, using strain actuation, actuators and sensors can be collocated. Further, hydraulic lag associated with moving control surface, and aerodynamic lag, which exists in the realisation of controlling aerodynamic forces and moments, will not be present when strain actuators are used.

Strain actuation, when used to directly regulate the lifting surface, has additional significance.

Horikawa and Dowell³⁷ performed simple feedback control simulations on a two degrees-of-freedom (DOFs) airfoil system and studied the effectiveness of these control laws in changing the flutter speed. Stability analysis with these feedback controls in place was also performed. Control realisation was assumed to be through trailing-edge actuator. Lazarus³⁸ considered a four-DOFs airfoil system with trailing and leading edge controls. Reich³⁹, *et al.* have investigated piezoceramic actuation as a means to realise flutter control in an aeroelastic wing model. The PARTI program at NASA⁴⁰ conducted proof-of-concept investigations on a five-foot span composite wing with piezoceramic patches bonded to 60 per cent of the inboard span. A maximum 12 per cent increase in flutter speed was experimentally observed. A dual approach, integrating structural tailoring and adaptive materials technology, has been used by Librescu⁴¹ to control of composite cantilever beam, which can be effectively used in aeroelastic control.

Effects of open-loop and closed-loop control mechanisms using strain actuation on an aeroelastic wing were reported by Lin⁴². The test model was designed to maximise piezoelectric control authority while maintaining the desired passive aeroelastic behaviour. The sweptback (angle 30°) wing model was selected with graphite-epoxy laminate as the primary load-carrying element of the wing. To maximise total actuator authority, SISO (single-input-single-output) design group E was used (the name indicates a particular piezoelectric patch as seen in Fig. 5).

Heeg⁴³ demonstrated flutter suppression using piezoelectric plates as actuators, both analytically as well as experimentally. The model consisted of a rigid wing and a flexible mount. The system permitted translational and rotational DOFs. The actuators made of PZT material were affixed to leaf springs of the mount system. External command signals applied to piezoelectric actuators exerted control over the closed-loop damping and stiffness properties of the leaf springs which were in the form of plates. The open-loop flutter velocity prediction

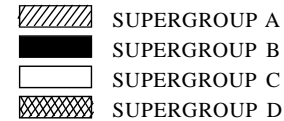

SUPERGROUP E INCLUDES ALL INDIVIDUAL ACTUATORS

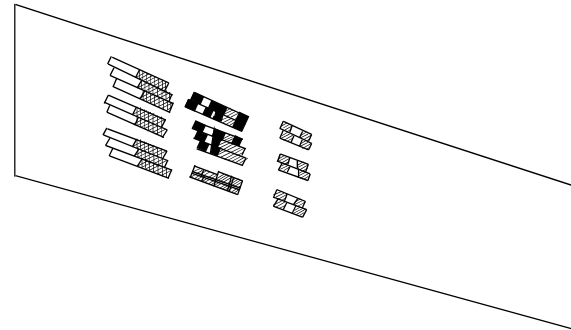

Figure 5. Combination of PZT patches⁴³.

was 1.5 per cent conservative while the closed-loop flutter velocity prediction was 7.6 per cent conservative. The analysis indicated that the flutter velocity would be increased by 15.7 per cent with the control law, whereas experimentally it showed 20 per cent.

Rayleigh-Ritz method was used by Nam and Kim⁴⁴ to develop the equations of motion for laminated plate-wing model with segmented piezoactuators. The benefits of structural tailoring and adaptive materials to control vibration and static aeroelastic characteristics of advanced aircraft wings as hybrid approach has been attempted by Librescu⁴⁵. The structural model consists of a thin-walled closed sectional cantilever beam. It was demonstrated that the synergistic effect resulting from the simultaneous use of tailoring of anisotropic composite materials, through the implementation of a proper ply-angle configuration and control by means of adaptive materials, produced a wing with better dynamic and static aeroelastic characteristics than would have been produced with either tailoring or control alone. It was concluded that incorporation of both technologies can provide an expanded performance envelope of flight vehicles, without weight penalties.

The methodology to actuate trailing-edge flap in a wing model using high-performance piezostack device was explored by Chandra and Chopra⁴⁶.

The linear motion of the actuator was converted to the rotary motion for flap actuation using a hinge offset mechanism (Fig. 6). The mechanically amplified stroke of a piezostack actuator was translated to rotary motion to actuate the flap via push rod.

This model was tested to evaluate the performance of the flap actuation, both without and with aerodynamic forces. The influence of free stream velocity and angle of attack on flap deflection was studied. A 30 per cent decrease in flap deflection at free-stream velocity at 28 m/s was noticed.

Nitzsche⁴⁷ investigated both theoretically and experimentally an active control system for vertical fin buffeting alleviation using stain actuation. Two groups of actuators consisting of piezoelectric elements distributed over the structure were designed to achieve authority over the first and the second modes of the vertical fin and demonstrated that

the actual reduction up to 18 per cent in root-mean-square (RMS) values of the fin dynamic response, measured by the strain transducer at the critical point for fatigue at the root, could be achieved for the second mode under the most severe buffet condition.

Barret⁴⁸ used directionally-attached piezoelectric (DAP) elements to develop active plate and missile wing. A twist of $14^\circ/\text{m}$ was achieved for a 0.762 mm aluminum with antisymmetrically laminated DAP elements. Torque plate was used to induce pitch deflections in a subsonic missile fin with a NACA 0012 profile and an aspect ratio of 1.4. The wing could show a pitch deflection of 8.5° .

It has been found that greater control authority along with a lower weight penalty is achievable using adaptive aeroelastic structures for a variety of wing designs. Thus, strain actuated adaptive

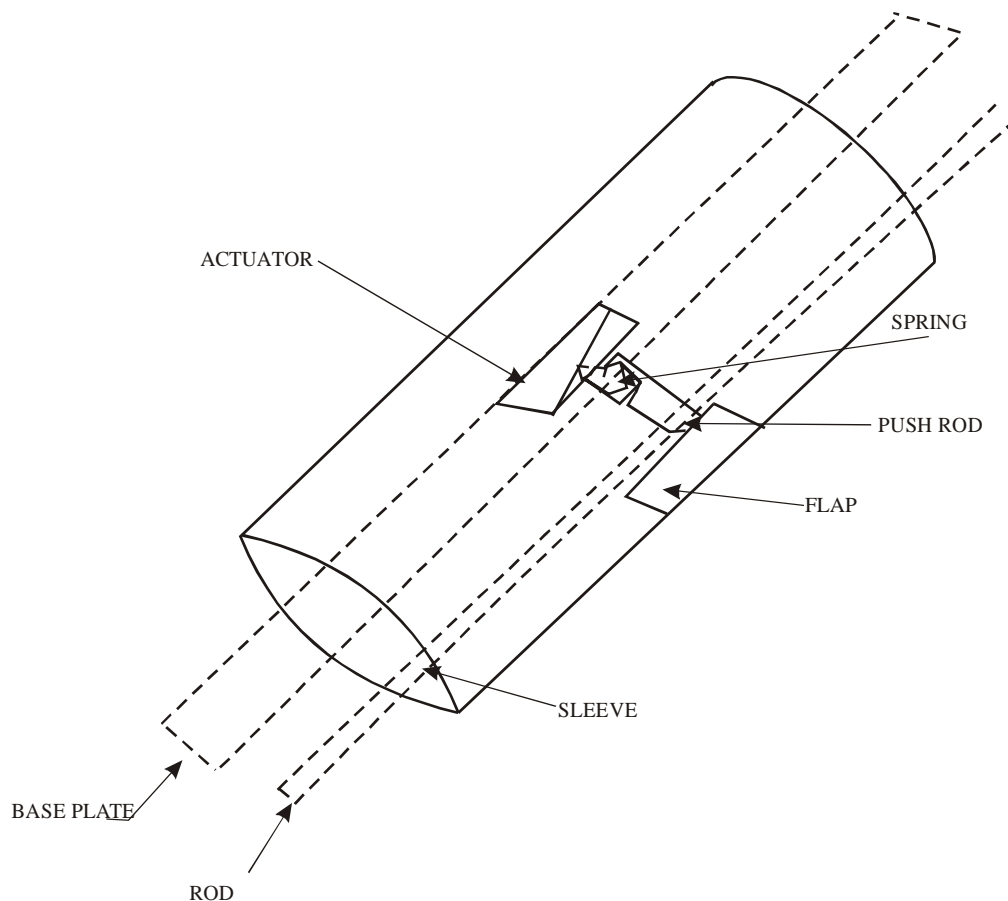

Figure 6. Flap control using PZT stacks⁴⁶.

wings may be used rather than conventional lifting surfaces to increase performance while reducing weight and maximising the lift-to-drag ratio for many flight conditions.

Kandagal and Venkatraman⁴⁹ studied various feedback measurement conditions for SISO feedback control and strain actuation in heave and pitch directions to quantify their effect on flutter. Flutter speed can be increased by more than 50 per cent through strain actuation in the pitch direction.

6. CONCLUSION

The research in the area of smart materials and adaptive structures has huge potential to make substantial contributions in enhancing performance, reliability of aero-mechanical systems. Significant advances have been made in the fields of piezoelectric, electrostrictive, magnetostrictive materials, reinforced composites, smart memory alloys, electro-rheological and magneto-rheological fluids, intelligent sensor and actuator systems, in formulating the techniques for modelling, simulation, health monitoring, and control of complex systems.

REFERENCES

1. Crawley, E.F. Intelligent structures for aerospace: A technology overview and assessment. *AIAA Journal*, 1994, **32**(8), 1689-699.
2. Tani, J.; Takagi, T. & Qiu, J. Intelligent materials systems: Application of functional material. *Trans. ASME, Appl. Mech. Rev.*, 1998, **51**(8), 505-21.
3. Rao, S.S. & Sunar, M. Piezoelectricity and its use in disturbance sensing and control of flexible structures: A survey. *Trans. ASME, Appl. Mech. Rev.*, 1994, **47**(3), 113-23.
4. Newnham, R.E. & Ruschu, G.R. Smart electronics. *J. Am. Ceramic Soc.*, 1991, **74**(3), 463-80.
5. Lowey, R.G. Recent developments in smart structures with aeronautical applications. *Smart Mater. Struct.*, 1997, **6**, R11-R42.
6. Garg, D.P.; Zirky, M.A. & Anderson, G.L. Current and potential future research activities in adaptive structures: An ARO perspective. *Smart Mater. Struct.*, 2001, **10**, 610-23.
7. Chopra, I. Review of state-of-the-art of smart structures and integrated systems. *AIAA Journal*, 2002, **40**(11), 2145-187.
8. Durr, J.K.; Ursula, H.S. & Zaglauer, H.W. On the integration of piezoceramic actuators in composite structures for aerospace applications. *J. Intell. Mater. Syst. Struct.*, 1999, **10**, 880-89.
9. Spillman Jr. W.B. Sensing and processing for smart structures. *Proceedings IEEE*, 1996, **84**(1), 68-77.
10. Gandhi, M.V. & Thompson, B.S. Smart materials and structures. Chapman and Hall Ltd, New York, 1992.
11. Hooker, M.W. Properties of PZT-based piezoelectric ceramics between -150 and 250 degree centigrade. NASA, Washington, 1998. Report No. NASA-CR-1998-208708.
12. Herman Shen, M.H. A new modelling technique for piezoelectrically-actuated beams. *Computers Structures*, 1995, **57**(3), 361-66.
13. Bailey, T. & Hubbard, (Jr), J.E. Distributed piezoelectric-polymer active vibration control of a cantilever beam. *Journal of Guidance*, 1985, **8**(5), 605-11.
14. Crawley, E.F. & Anderson, E.H. Detailed models of piezoceramic actuation of beams. *J. Intelligent Mater. Syst. Struct.*, 1990, **1**, 4-25.
15. Sirohi, J. & Chopra, I. Fundamental behaviour of piezoelectric sheet actuators. *J. Intelligent Mater. Syst. Struct.*, 2000, **11**, 47-61.
16. Im, S. & Atluri, S.N. Effects of a piezo-actuator on a finitely deformed beam subjected to general loading. *AIAA Journal*, 1989, **27**(12), 1801-807.
17. Chaudhry, Z. & Rogers, C.A. Enhancing induced strain actuator authority through discrete attachment to structural elements. *AIAA Journal*, 1993, **31**(7), 1287-292.

18. Hagood, N.W. & von Flotow, A. Damping of structural vibrations with piezoelectric materials and passive electrical networks. *J. Sound Vib.*, 1991, **146**(2), 243-68.
19. Hagood, N.W.; Aldrich, J.B. & von Flotow, A.H. Design of passive piezoelectric damping for space structures, Technical Report, NASA, 1994 No. NASA-CR-4625.
20. Lesieutre, G.A. Vibration damping and control using shunted piezoelectric materials. *Shock Vib. Digest*, 1998, **30**(3), 187-95.
21. Law, H.H.; Rossiter, P.L.; Simon, G.P. & Koss, L.L. Characterisation of mechanical vibration damping by piezoelectric material. *J. Sound Vib.*, 1996, **197**(4), 489-13.
22. Davis, C. & Lesieutre, G.A. A modal strain energy approach to the prediction of resistively shunted piezoceramic damping. *J. Sound Vib.*, 1995, **184**(1), 129-39.
23. Hagood, N.W. & Crawley, E.F. Experimental investigation of passive enhancement of damping in mechanical systems. *Journal of Guidance*, 1991, **14**(6), 1100-109.
24. Steffen Jr. V. & Inman, J.D. Optimal design of piezoelectric materials for vibration damping in mechanical systems. *J. Intelligent Mater. Syst. Struct.*, 1999, **10**, 945-55.
25. Kandagal, S.B. & Venkatraman, Kartik. Structural vibration control using resistively shunted piezoceramics. *Struct. Eng. Mech.*, 2002, **14**(5), 521-42.
26. Kandagal, S.B. & Venkatraman, Kartik. Form factors for vibration control of beams using resistively shunted piezoceramics. *J. Sound Vib.*, 2004, **278**, 1123-133.
27. Sarvanos, D.A. Damped vibration of composite plates with passive piezoelectric resistor elements. *J. Sound Vib.*, 1999, **221**(3), 867-85.
28. Tang, J. & Wang, K.W. Vibration control of rotationally periodic structures using piezoelectric shunt networks and active compensation, *Trans. ASME, J. Vib. Acoustics*, 1999, **121**, 379-90.
29. Agnani, A.; Mastroddi, F. & Polli, G.M. Shunted piezoelectric patches in elastic and aeroelastic vibrations. *Computers and Structures*, 2003, **81**, 91-105.
30. Tzou, H.S. & Tseng, C.I. Distributed model identification and vibration control of continua: Piezoelectric finite element formulation and analysis. *Trans. ASME, J. Dyn. Syst, Measure. Cont.*, 1991, **113**, 500-05.
31. Fanson, J.L. & Caughey, T.K. Positive position feedback control for large space structures. *AIAA Journal*, 1990, **28**(4), 717-24.
32. Denoyer, K.K. & Kwak, M.K. Dynamic modelling and vibration suppression of a slewing structure utilising piezoelectric sensors and actuators. *J. Sound Vib.*, 1996, **189**(1), 13-31.
33. Anderson, E.H. & Hagood, N.W. Simultaneous piezoelectric sensing/actuation: Analysis and application to controlled structures. *J. Sound Vib.*, 1994, **174**(5), 617-39.
34. Kubrusly, C.S. & Malebranche, H. Sensors and controllers location in distributed systems: A survey. *Automatica*, 1985, **21**(2), 117-28.
35. Lim, K.B. Method for optimal actuator and sensor placement for large flexible structures. *Journal of Guidance*, 1992, **15**(2), 49-56.
36. Sunar, M. & Rao, S.S. Distributed modelling and actuator location for piezoelectric control systems. *AIAA Journal*, 1996, **34**(10), 2209-211.
37. Horikawa, H. & Dowell, E.H. An elementary explanation of the flutter mechanism with active feedback controls. *Journal of Aircraft*, 1979, **4**, 225-32.
38. Lazarus, K.B.; Crawley, E.F. & Lin, C.Y. Fundamental mechanism of aeroelastic control with control surface and strain actuation. *J. Guid. Cont. Dyn.*, 1995 **18**(1), 10-17.

39. Reich, G.W.; Van Scholar.; M.C. Lin.; C.Y. & Crawley, E.F. An active aeroelastic wing model for vibration and flutter suppression. AIAA, 1995. Technical Report AIAA-95-1193-CP.
40. Mc Gowan, A.; Wilkie, M.R; Moses, W.K.; Renee C, R.W.; Florance, J.P.; Wieseman, C.D.; Reaves, M.C.; Taleghani, B.K.; Mirick, P.H. & Wilbur, M.L. Aeroservoelastic and structural dynamic research on smart structures conducted at NASA Langley Research Centre. SPIE, 1998, **3326**. pp.188-201.
41. Librescu, L.; Meirovitch, L. & Na, S.S. Control of cantilever vibration via structural tailoring and adaptive materials. *AIAA Journal*, 1997, **35**(8), 1309-315.
42. Lin, C.Y.; Crawley, E.L. & Heeg, J. Open- and closed-loop results of a strain-actuated active aeroelastic wing. *Journal of Aircraft*, 1996, **33**(5), 987-94.
43. Heeg, J. An analytical and experimental investigation of flutter suppression via piezoelectric actuation. AIAA, 1992. Technical Report AIAA-92-2106-CP.
44. Nam, C. & Kim, Y. Optimal design of composite lifting surface for flutter suppression with piezoelectric actuators. *AIAA Journal*, 1995, **33**(10), 1897-904.
45. Librescu, L.; Meirovitch & Song, O. Integrated structural tailoring and control using adaptive materials for advanced aircraft wings. *Journal of Aircraft*, 1996, **33**(1), 203-13.
46. Chandra, R. & Chopra, I. Actuation of trailing edge flap in a wing model using piezostack device. *J. Intelligent Mater. Syst. Struct.*, 1998, **9**, 847-53.
47. Nitzsche, F.; Liberatore, S. & Zimcik, D.G. Theoretical and experimental investigations on an active control system for vertical fin buffeting alleviation using strain actuation. *The Aeronautical Journal*, 2001, **105**(1047), 277-85.
48. Barret, R. Active plate and missile wing development using directionally attached piezoelectric elements. *AIAA Journal*, 1994, **21**(3), 601-09.
49. Kandagal, S.B. & Venkatraman, Kartik. Closed-loop flutter control using strain actuation. *The Aeronautical Journal*, 2004, **108**, 271-75.

Contributors



Dr S.B. Kandagal obtained his MTech from the Mangalore University in 1992 and PhD (IISc), Bangalore, in 2005. He is Senior Scientific Officer in Department of Aerospace Engineering, Indian Institute of Science, Bangalore. His areas of specialisation are: Vibration control, aeroelasticity, structural mechanics, experimental modal analysis to solve vibration problems. He has one patent to his credit and published 10 papers in scientific journals.



Dr Kartik Venkatraman is presently Assistant Professor in the Department of Aerospace Engineering, Indian Institute of Science, Bangalore. His research areas are dynamics and aeroelasticity. He has studied problems on unsteady flow past airfoil and airfoil cascades, and problems in controlling vibration and aeroelastic instabilities using active materials.