

## Evaluation of the Effect of Radio Frequency Interference on Global Positioning System (GPS) Accuracy via GPS Simulation

S. Dinesh\*, M. Mohd Faudzi, and M.A. Zainal Fitry

Science and Technology Research Institute for Defence, Malaysia

\*E-mail: [dinesh.sathyamoorthy@stride.gov.my](mailto:dinesh.sathyamoorthy@stride.gov.my)

### ABSTRACT

In this study, Global positioning system (GPS) simulation is employed to study the effect of radio frequency interference (RFI) on the accuracy of two handheld GPS receivers; Garmin GPSmap 60CSx (evaluated GPS receiver) and Garmin GPSmap 60CS (reference GPS receiver). Both GPS receivers employ the GPS L1 coarse acquisition (C/A) signal. It was found that with increasing interference signal power level, probable error values of the GPS receivers increase due to decreasing carrier-to-noise density ( $C/N_0$ ) levels for GPS satellites tracked by the receivers. Varying probable error patterns are observed for readings taken at different locations and times. This was due to the GPS satellite constellation being dynamic, causing varying GPS satellite geometry over location and time, resulting in GPS accuracy being location/time dependent. In general, the highest probable error values were observed for readings with the highest position dilution of precision (PDOP) values, and vice versa.

**Keywords:** Global positioning system, GPS simulation, radio frequency interference, carrier-to-noise density

### 1. INTRODUCTION

There is a steady growth in the entrenchment of global navigation satellite systems (GNSS) in current and upcoming markets, having penetrated various consumer products, such as cell phones, personal navigation devices (PNDs), cameras and assimilation with radio-frequency identification (RFID) tags, for various applications, including navigation, surveying, timing reference and location based services (LBS). While the global positioning system (GPS), operated by the US Air Force (USAF), is the primarily used GNSS system worldwide, the upcoming Galileo and Compass systems, and the imminent conversion of *global'naya navigatsionnaya sputnikovaya sistema* (GLONASS) signals from frequency division multiple access (FDMA) to code division multiple access (CDMA) look set to make multi-satellite GNSS configurations the positioning, navigation and timing (PNT) standard for the future.

However, many GNSS users are still not fully aware of the vulnerabilities of GNSS systems to various error parameters, such as ionospheric and tropospheric delays, satellite clock, ephemeris and multipath errors, satellite positioning and geometry, and signal interferences and obstructions. These error parameters can severely affect the accuracy of GNSS readings, and in a number of cases, disrupt GNSS signals<sup>1-6</sup>.

One particular vulnerability that has received significant attention is jamming. Jamming is defined as the broadcasting of a strong signal that overrides or obscures the signal being jammed<sup>7,8</sup>. Since GNSS satellites, powered by photocells, are approximately 20,200 km above the earth surface, GNSS signals that reach the Earth have very low power levels (approximately -160 dBm to -130 dBm), rendering them highly susceptible to jamming<sup>5, 9-12</sup>. For example, a simple 1 W battery-powered

jammer can block the reception of GNSS signals approximately within a radius of 35 km from the jammer<sup>10</sup>. Given the various incidents of intentional and unintentional jamming of GNSS signals, including military GNSS signals<sup>9,13-16</sup>, the development of various GNSS anti-jamming technologies has received significant attention<sup>11,17-21</sup>. In addition, many current GNSS receiver evaluations concentrate on radio frequency interference (RFI) operability<sup>22-25</sup>.

In order to study the effect of RFI on the GPS L1 coarse acquisition (C/A) signal, the Science and Technology Research Institute for Defence (STRIDE), Malaysia conducted a series of tests specifically aimed at evaluating the minimum interference signal power levels required to jam various GPS receivers<sup>26,27</sup>. However, interference signals with power levels below the minimum jamming threshold could still severely distort GPS accuracy, rendering it useless for applications requiring high precision. To this end, Dinesh<sup>28</sup>, *et al.* studied the effect of RFI on GPS accuracy. The study was conducted via field evaluations using live GPS signals. However, such field evaluations are subject to various error parameters which are uncontrollable by users.

The ideal GPS receiver evaluation methodology would be using a GPS simulator, which can be used to generate multi-satellite GPS configurations, transmit GPS signals which simulate real world scenarios, and adjust the various error parameters. This would allow for the evaluations of GPS receiver performance under various repeatable conditions, as defined by users. As the evaluations are conducted in controlled laboratory environments, they will not be inhibited by unwanted signal interferences and obstructions<sup>29-32</sup>.

In this study, GPS simulation is employed to study the

effect of RFI on the accuracy of two handheld GPS receivers; Garmin GPSmap 60CSx (evaluated GPS receiver)<sup>33</sup> and Garmin GPSmap 60CS (reference GPS receiver)<sup>34</sup>. Both GPS receivers employ the GPS L1 C/A signal, which is an unencrypted civilian GPS signal widely used by various GPS receivers. The signal has a fundamental frequency of 1,575.42 MHz, and a code structure which modulates the signal over a 2 MHz bandwidth<sup>2, 35, 36</sup>.

**2. METHODOLOGY**

The apparatus used in the study were an Aeroflex GPSG-1000 GPS simulator<sup>37</sup>, an Advantest U3751 spectrum analyser<sup>38</sup>, an IFR 2023B signal generator<sup>39</sup>, a Hyperlog 60180 directional antenna<sup>40</sup>, and a notebook running GPS Diagnostics<sup>41</sup> v1.05. The study was conducted in the STRIDE semi-anechoic chamber<sup>42</sup> to avoid external interferences signals and multipath errors. The test setup employed is as shown in Fig. 1. Simulated GPS signals were generated using the GPS simulator and transmitted via the coupler, while interference signals were generated using the signal generator and transmitted via the

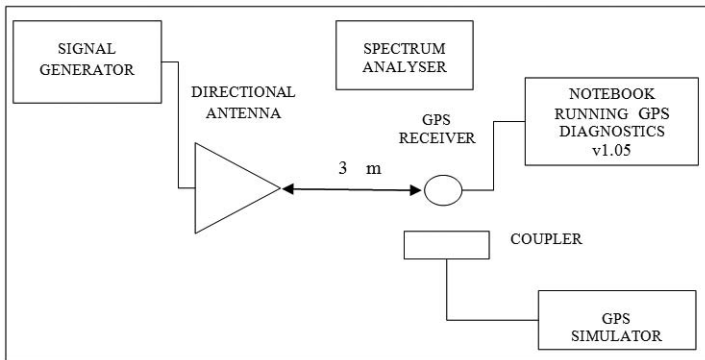

**Figure 1. The test setup employed.**

directional antenna. The following assumptions were made for the tests:

- No ionospheric or tropospheric delays
- Zero clock and ephemeris error
- No multipath fading or unintended obstructions
- No unintended interference signals.

The date of simulation was set at 10 January 2012. The almanac data for the period was downloaded from the US Coast Guard’s web site<sup>43</sup>, and imported into the GPS simulator. The GPS signal power level was set at -131dBm, which is the highest value permitted by the GPS simulator. For each GPS receiver, the test procedure was conducted for coordinated universal time (UTC) times of 0000, 0300, 0600, and 0900 for the following coordinates:

- N 2° 58’ E 101° 48’ (Kajang, Selangor, Malaysia)
- N 39° 45’ W 105° 00’ (Denver, Colorado, USA)
- S 16° 55’ E 145° 46’ (Cairns, Queensland, Australia)

- S 51° 37’ W 69° 12’ (Rio Gallegos, Argentina).  
Trimble Planning<sup>44</sup> was used to estimate GPS satellite coverage in the test areas for the period of the tests as shown in Fig. 2.

Once a location fix was obtained with the GPS receiver, the values of horizontal probable error (HPE), vertical probable error (VPE) and estimate probable error (EPE) were recorded using GPS Diagnostics. The interference signal used was a frequency modulated (FM) signal with carrier frequency of 1,575.42 MHz, bandwidth of 2 MHz and information frequency of 5 kHz. Interference signal transmission was started at power level of -140 dBm. The power level was increased by increments of 3 dBm, and the corresponding values of HPE, VPE and EPE were recorded.

**3. RESULTS AND DISCUSSION**

Prior to transmission of interference signals, the evaluated GPS receiver recorded lower probable error values as compared to the reference GPS receiver as shown in Table 1. This occurred as the evaluated GPS receiver has higher receiver sensitivity, and hence, is able to obtain lower PDOP values. In addition, it has lower receiver noise, reducing the value of its user equivalent ranging error (UERE), which is the total expected magnitude of position errors due to measurement uncertainties from the various error components for a particular receiver<sup>2, 35, 36</sup>.

For all the readings, the values of VPE are larger than HPE, as GPS receivers can only track satellites above the horizon, resulting in GPS height solution being less precise than the horizontal solution<sup>28, 35, 36, 45</sup>. The difference between VPE and HPE values is significantly larger for the reference GPS receiver as compared to the evaluated GPS receiver. The reference GPS receiver, having lower receiver sensitivity, has

**Table 1. HPE, VPE, and EPE values prior to transmission of interference signals**

Location	UTC time	Probable error (m)					
		Evaluate GPS receiver			Reference GPS receiver		
		HPE	VPE	EPE	HPE	VPE	EPE
Kajang	0000	2.9	3.6	4.6	10.3	16.3	19.2
	0300	2.7	4.8	5.5	8.6	16.6	18.7
	0600	2.5	3.5	4.4	7.1	13.1	14.9
	0900	1.9	4.9	5.3	7.8	22.3	23.6
Denver	0000	3.1	3.2	4.5	5.1	6.3	8.1
	0300	2.5	3.5	4.2	3.8	6.2	7.3
	0600	3.3	3.4	4.7	5.7	8.3	10.1
	0900	3.1	3.2	4.5	8.3	11.4	14.1
Cairns	0000	4.6	13.7	14.5	13.7	19.5	23.8
	0300	2.5	3	3.9	4.9	6.1	7.8
	0600	8.3	11.6	14.3	13	23.3	26.7
	0900	2.9	3.9	4.9	5.3	6.3	8.2
Rio Gallegos	0000	2.4	4	4.7	4.2	6.6	7.8
	0300	6.6	9.6	11.7	11.8	14	18.3
	0600	3.1	3.2	4.5	4.8	5.5	7.3
	0900	2.8	4.6	5.4	5.4	7.3	9.1

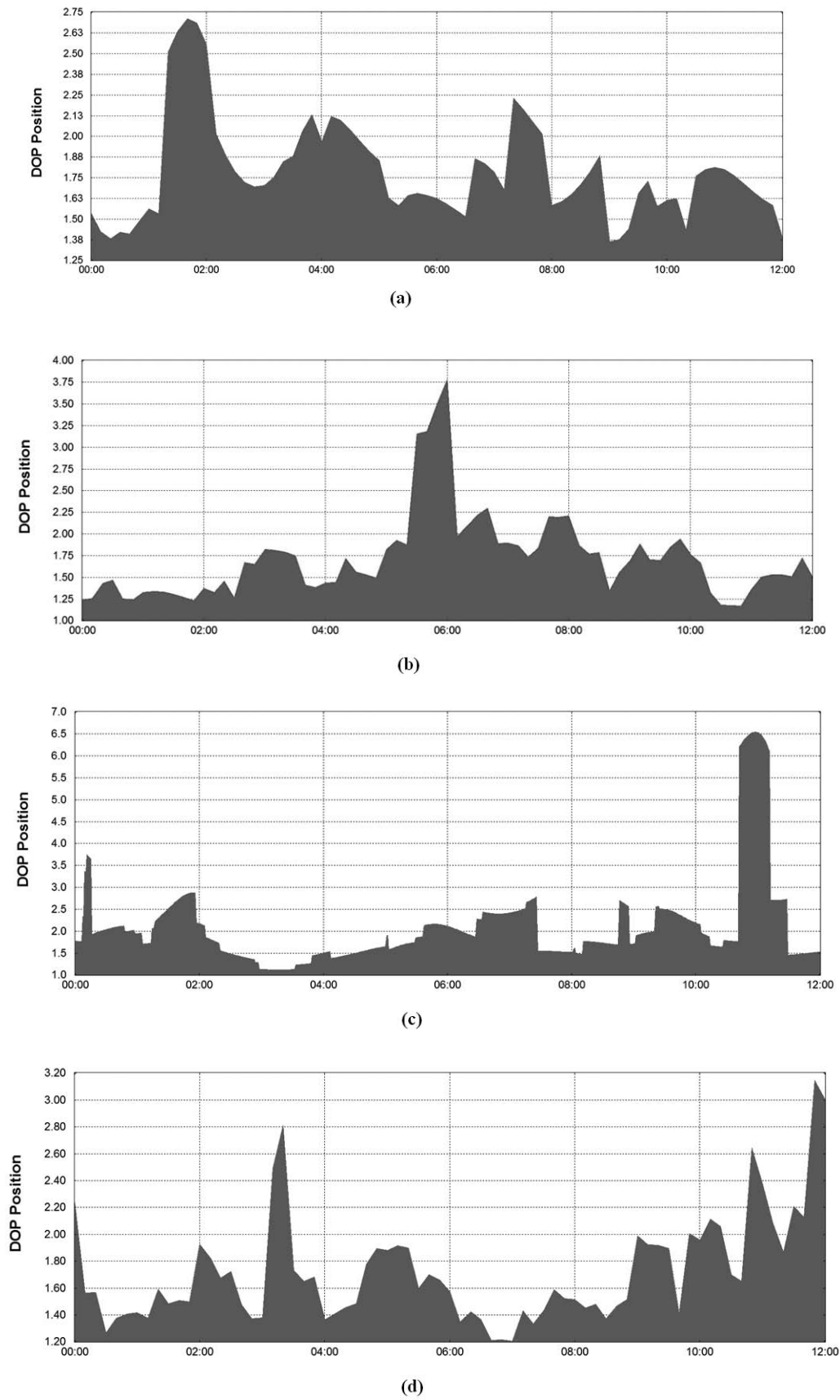

**Figure 2. Position dilution of precision (PDOP) of GPS coverage at the test areas for the period of the tests: (a) Kajang, (b) Denver (c) Cairns (d) Rio Gallegos. (Source: Screen captures from Trimble Planning)**

much better horizontal component accuracy as compared to the vertical component. For the GPS evaluated receiver, with higher receiver sensitivity, while the horizontal component accuracy is still larger, the difference with the vertical component is much smaller.

As observed in Figs 3-10, with increasing interference signal power level, probable error values increase due to decreasing carrier-to-noise density ( $C/N_0$ ) levels for GPS satellites tracked by the receiver, which is the ratio of received GPS signal power level to noise density. Lower  $C/N_0$  levels

result in increased data bit error rate when extracting navigation data from GPS signals, and hence, increased carrier and code tracking loop jitter. This, in turn, results in more noisy range measurements and thus, less precise positioning<sup>2, 28, 35, 36, 46</sup>. At some points, depending on GPS coverage, the horizontal component accuracy became lower than the vertical component due to significant reduction of  $C/N_0$  levels for overhead satellites as compared to satellites above the horizon.

Varying probable error patterns are observed for the each of the readings. This is due to the GPS satellite constellation

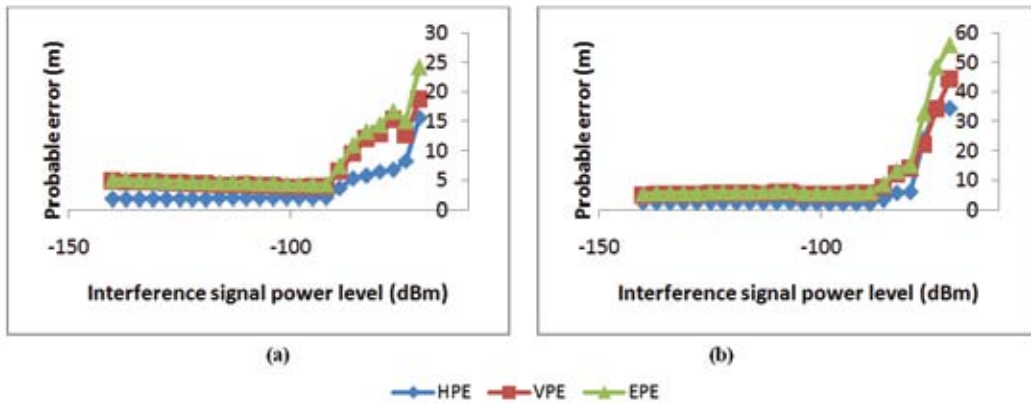

Figure 3. Recorded probable error values for the evaluated GPS receiver at Kajang for periods of: (a) Best coverage: 0900 (b) Worst coverage: 0300.

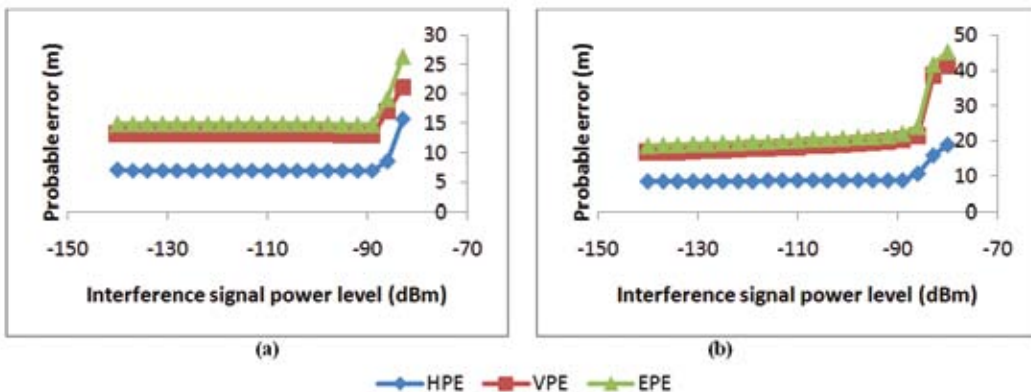

Figure 4. Recorded probable error values for the reference GPS receiver at Kajang for periods of: (a) Best coverage: 0900 (b) Worst coverage: 0300.

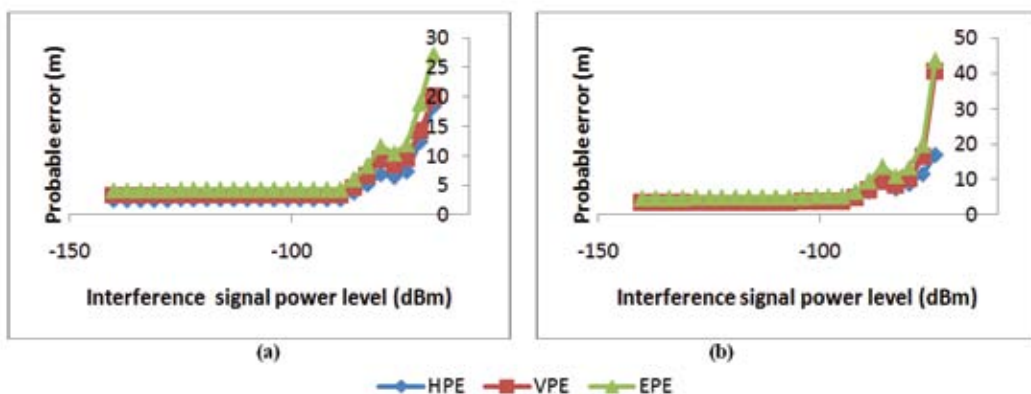

Figure 5. Recorded probable error values for the evaluated GPS receiver at Denver for periods of: (a) Best coverage: 0600 (b) Worst coverage: 0300.

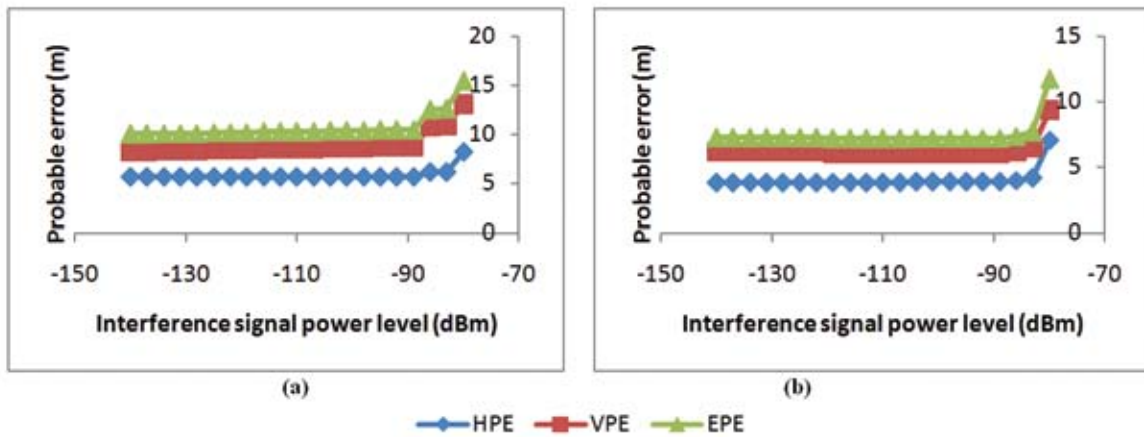

Figure 6. Recorded probable error values for the reference GPS receiver at Denver for periods of: (a) Best coverage: 0600 (b) Worst coverage: 0300.

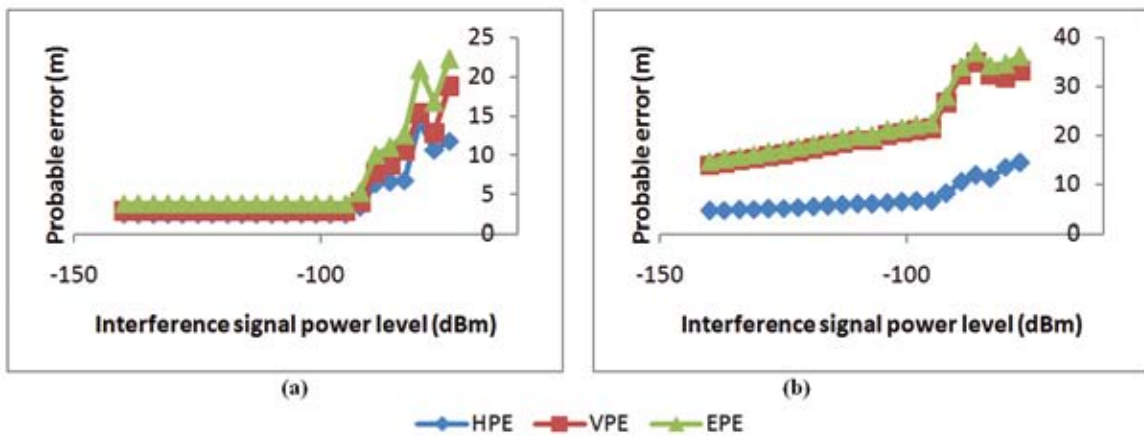

Figure 7. Recorded probable error values for the evaluated GPS receiver at Cairns for periods of: (a) Best coverage: 0300 (b) Worst coverage: 0000.

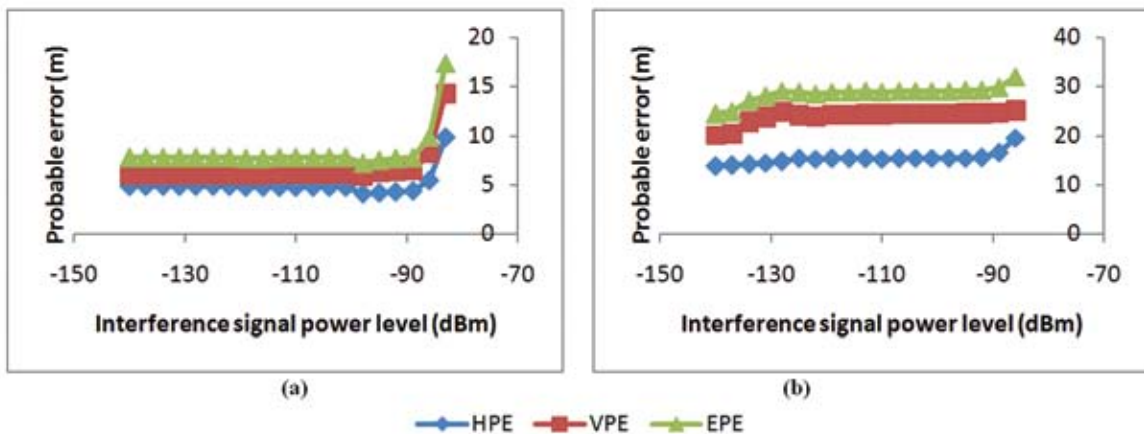

Figure 8. Recorded probable error values for the reference GPS receiver at Cairns for periods of: (a) Best coverage: 0300 (b) Worst coverage: 0000.

being dynamic, causing varying GPS satellite geometry over location and time, resulting in GPS accuracy being location/time dependent<sup>2,28,35,36,45</sup>. In general, the highest probable error values were observed for readings with the highest PDOP values (Kajang at 0300, Denver at 0600, Cairns at 0000 and Rio Gallegos at 0300), while the lowest probable error values were observed for readings with the lowest PDOP values

(Kajang at 0900, Denver at 0300, Cairns at 0300 and Rio Gallegos at 0600).

It was observed that the interference signal power levels required to affect the location fixes of the GPS receivers (Table 2) are significantly high as compared to the GPS signal power level, as the noise-like C/A code structure allows for the signal to be received at low levels of interferences.

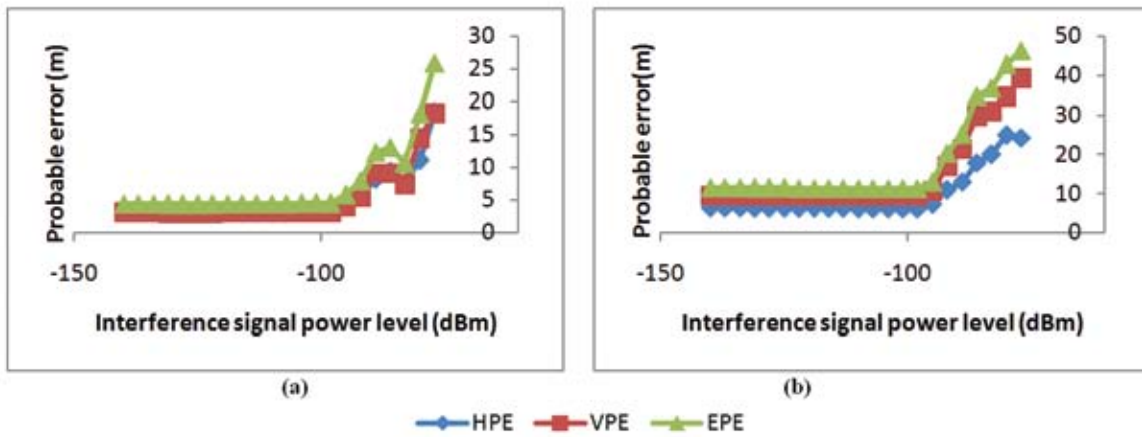

Figure 9. Recorded probable error values for the evaluated GPS receiver at Rio Gallegos for periods of: (a) Best coverage: 0600 (b) Worst coverage: 0300.

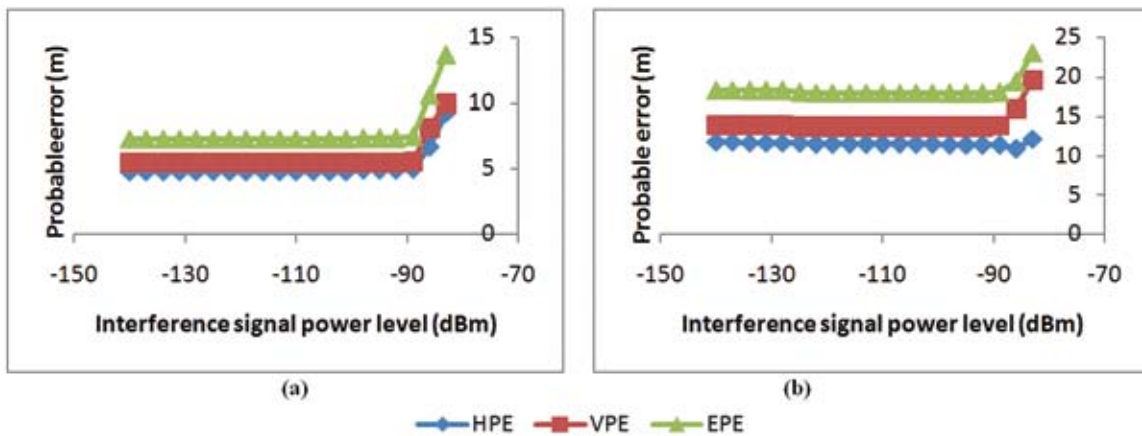

Figure 10. Recorded probable error values for the reference GPS receiver at Rio Gallegos for periods of: (a) Best coverage: 0600 (b) Worst coverage: 0300.

The precision encrypted (P(Y) code (restricted to the US military) has a more robust structure, modulating the L1 and L2 signals over 20 MHz bandwidths, and has better resistance to interference<sup>2,35,36</sup>.

For a number of the readings, it is observed that the interference signal power levels required to cause the first degradation of accuracy are higher for the reference GPS receiver as compared to the evaluated GPS receiver, due to the initial probable errors of the reference GPS receiver being significantly higher. The probable errors of the evaluated GPS receiver increased to values that are significantly higher than the reference GPS receiver (Tables 3 and 4). This occurred as the evaluated GPS receiver requires higher interference signal power levels to be jammed as compared to the reference GPS receiver. Interference signal power levels that are just slightly lower than the evaluated GPS receiver's jamming threshold cause significant degradation of accuracy. The tests conducted in this study employed GPS signal power level of -131 dBm. Usage of lower GPS signal power levels would result in reduced  $C/N_0$  levels and hence, higher rates of increase of probable error values. In addition, the minimum interference signal power levels required to jam the GPS receivers would also be lower.

#### 4. CONCLUSIONS

Based on the results of this study, it is found that with increasing interference signal power level, probable error values GPS receivers increase due to decreasing  $C/N_0$  levels for GPS satellites tracked by the receivers. Varying probable error patterns are observed for readings taken at different locations and times. This is due to the GPS satellite constellation being dynamic, causing varying GPS satellite geometry over location and time, resulting in GPS accuracy being location/time dependent. In general, the highest probable error values were observed for readings with the highest PDOP values, and vice versa.

This study has highlighted the relative ease to conduct GNSS jamming. Low power level interference signals, from intentional or unintentional sources, can cause the disruption of GNSS signals. Given the increasing dependence on GNSS for PNT applications, GNSS disruptions could prove to be problematic, if not disastrous. Hence, GNSS vulnerability mitigation steps should be given emphasis, including navigation/positioning/timing backups, making full use of ongoing GNSS modernisation programs, increased ability to identify and locate GNSS jammers, integrity monitoring and augmentation, and anti-jamming technologies.

**Table 2. Interference signal power levels at which the first degradation of accuracy is noticed and the location fix is lost**

Location	UTC time	Interference signal power level (dBm)			
		Evaluated GPS receiver		Reference GPS receiver	
		First degradation of accuracy	Location fix lost	First degradation of accuracy	Location fix lost
Kajang	0000	-86	-65	-83	-77
	0300	-86	-68	-86	-77
	0600	-86	-65	-83	-80
	0900	-89	-68	-86	-80
Denver	0000	-89	-68	-83	-77
	0300	-86	-65	-80	-77
	0600	-92	-71	-80	-77
	0900	-86	-68	-83	-77
Cairns	0000	-92	-74	-86	-83
	0300	-92	-71	-86	-80
	0600	-92	-74	-86	-80
	0900	-92	-71	-83	-80
Rio Gallegos	0000	-92	-71	-86	-80
	0300	-95	-74	-86	-80
	0600	-92	-74	-86	-80
	0900	-92	-72	-86	-80

**Table 3. Maximum probable errors for the GPS receivers prior to location fix loss**

Location	UTC time	Probable error (m)					
		Evaluated GPS receiver			Reference GPS receiver		
		HPE	VPE	EPE	HPE	VPE	EPE
Kajang	0000	27.2	30.7	41.0	12.2	17.8	21.6
	0300	34.5	44.1	56.0	18.8	41.2	45.3
	0600	21.5	30.0	36.9	10.5	24.3	26.5
	0900	15.5	18.6	24.2	15.7	21.2	26.4
Denver	0000	14.7	19.7	24.6	7.4	9.3	11.9
	0300	18.5	20.0	27.2	7.1	9.4	11.8
	0600	16.9	40.3	43.7	8.2	13.1	15.5
	0900	14.9	21.7	26.3	8.3	11.4	14.1
Cairns	0000	14.5	33.3	36.3	19.7	25.3	32.1
	0300	11.8	18.9	22.3	9.9	14.3	17.4
	0600	19.7	18.4	27.0	19.7	24.0	31.0
	0900	10.3	24.7	26.8	9.6	14.0	17.0
Rio Gallegos	0000	19.8	33.8	39.2	12.2	14.3	18.8
	0300	24.4	39.5	46.4	12.2	19.6	23.1
	0600	18.4	18.3	26.0	9.3	10.0	13.7
	0900	18.4	24.5	30.6	7.7	10.4	12.9

**ACKNOWLEDGEMENT**

This study was conducted as part of the Tenth Malaysian Plan (RMK10) project entitled 'Evaluation of the effect of radio frequency interference (RFI) on global positioning system (GPS) signals via GPS simulation'. The authors are grateful to the officers and staff of the Instrumentation

and Electronics Technology Division (BTIE), Science and Technology Research Institute for Defence (STRIDE), in particular Mdm. Shalini Shafii, Mdm. Siti Zainun Ali, Mr Mohd Hasrol Hisam Mohd Yusof, Mr Ahmad Faridz Ahmad Ghafar and Mr Khairul Anwar Abd Rahim, for their support.

**Table 4. Difference between the initial and pre-location fix loss probable errors for the GPS receivers**

Location	UTC time	Probable error (m)					
		Evaluated GPS receiver			Reference GPS receiver		
		HPE	VPE	EPE	HPE	VPE	EPE
Kajang	0000	24.3	27.1	36.4	1.4	1.7	2.2
	0300	31.8	39.3	50.5	10.2	24.6	26.6
	0600	19.1	26.4	32.6	3.0	7.5	8.1
	0900	13.7	13.8	19.1	8.6	8.1	11.5
Denver	0000	11.4	15.5	19.2	2.3	3.0	3.8
	0300	16	16.6	23.0	3.3	3.2	4.5
	0600	13.5	36.9	38.9	2.5	4.8	5.4
	0900	11.8	18.5	21.9	2.8	5.2	5.8
Cairns	0000	11.4	15.5	19.2	2.3	3	3.8
	0300	16	16.6	23.0	3.3	3.2	4.5
	0600	13.5	36.9	38.9	2.5	4.8	5.4
	0900	11.8	18.5	21.9	2.8	5.2	5.8
Rio Gallegos	0000	17.4	29.8	34.5	6.8	7	9.7
	0300	17.9	29.9	34.8	0.4	5.6	4.8
	0600	15.3	15.1	21.5	4.5	4.5	6.4
	0900	15.6	19.9	25.3	2.3	3.1	3.9

**REFERENCES**

- Vulnerability assessment of the transport infrastructure relying on the global positioning system. John A. Volpe National Transportation Systems Center, Department of Transport, Washington DC, 2001. 99p.
- Kaplan, E.D. & Hegarty, C.J. Understanding GPS: Principles and applications. Artech House, Norwood, Massachusetts, 2006.
- Dinesh, S. Vulnerabilities of civilian global navigation satellite systems (GNSS) signals: A review. *Def. S&T Tech. Bull.*, 2009, 2(2), 100-114.
- Dinesh, S. Vulnerabilities of global navigation satellite systems (GNSS) signals to jamming and spoofing. GIS Day 2011, 17 March 2011, Universiti Putra Malaysia (UPM), Serdang, Selangor, 2011.
- Last, D. GNSS: The present imperfect. *Inside GNSS*, 2010, 5(5), 60-64.
- Royal Academy of Engineering. Global navigation space systems: Reliance and vulnerabilities, RAE, London, 2011.
- Department of Army, Electronic warfare in operations. Army Field Manual 3-36, Department of Army, Washington D.C., 2009.
- Poisel, A.R. Introduction to communication electronic warfare systems. Artech House, Boston, 2002.
- Adams, T.K. GPS vulnerabilities. *Mil. Rev.*, 2001, 1(2), 10-16,
- Papadimitratos, P. & Jovanovic, A. Protection and fundamental vulnerability of GNSS. In International Workshop on Satellite and Space Communications 2008 (IWSSC'08), France, 1-3 October 2008, Institut Supérieur de l'Aéronautique et de l'Espace (ISAE), Toulouse, France, 2008.
- Jones, M. The civilian battlefield: Protecting GNSS receivers from interference and jamming. *Inside GNSS*, 2011, 6(2), 40-49.
- Grant, A.; Williams, P.; Shaw, G.; De Voy, M. & Ward, N. Availability and safety: Many maritime users today believe that GPS will always be available. This is simply not the case. <http://www.gpsworld.com/transportation/marine/availability-and-safety-12038> [Accessed on 22 September 2011].
- Williams, S.F. Radar'd Out: GPS vulnerable to high-power Microwaves. <http://mg.gpsworld.com/gpsmg/article/articleDetail.jsp?id=320030> [Accessed on 4 November 2009].
- Jewell, J. GPS Insights. <http://www.gpsworld.com/defense/gps-insights-april-2007-8428> [Accessed 4 November 2009].
- Last, D.; Grant, A. & Ward, N. Demonstrating the effects of GPS jamming on marine navigation. In 3<sup>rd</sup> GNSS Vulnerabilities and Solutions Conference, Croatia, 5-8 September 2010, Baska, Croatia, 2010.
- Chosunilbo. N.Korea Jams GPS to Disrupt S.Korea-U.S. Drills. [http://english.chosun.com/site/data/html\\_dir/2011/03/07/2011030700567.html](http://english.chosun.com/site/data/html_dir/2011/03/07/2011030700567.html) [Accessed on 4 November 2009].
- Gustafon, D.; Dowdle, J. & Flueckiger, K. A high anti-jam GPS-based navigator. In Proceedings of the Institute of Navigation, Massachusetts, 28-30 June 2000, Cambridge, Massachusetts, 2000.
- Loefering, G.S. Dual-resistant antijamming architecture



- for GPS-guided air vehicle navigation system. *Technol. Rev. J.*, 2006, **14**(1), 1-10.
19. Meng, D.; Feng, Z. & Lu, M. Anti-jamming with adaptive arrays utilizing power inversion algorithm. *Tsinghua Sci. Tech.*, 2008, **13**(6), 796-799.
  20. Zhuang, X.; Cui, X.; Lu, M. & Feng, Z. Reduced-rank space-time processing for anti-jamming GPS receivers. *Tsinghua Sci. Tech.*, 2009, **14**(2), 189-195.
  21. Wilde, W.D. & Willems, T. Designing GNSS receivers to mitigate against interference. In *GPS Jamming & interference: A clear and present danger*, 23 February 2010, National Physics Laboratory, Teddington, 2010.
  22. Institute of Navigation. Institute of Navigation Standard 101 (ION STD 101): Recommended test procedures for GPS receivers, revision C. ION, Manassas, Virginia, 1997.
  23. Gautier, J. GPS/ INS Generalized evaluation tool (GIGET) for the design and testing of integrated navigation systems. Stanford University, Palo Alto, California, 2003. PhD Thesis.
  24. Weinstein, B.; Akos, D.; Vinande, E. & Chu, T. GNSS Receiver evaluation: Record-and-playback test methods. <http://www.gpsworld.com/transportation/gnss-receiver-evaluation-9302> [Assessed on 6 March 2010].
  25. Boulton, P.; Borsato, R.; Butler, B. & Judge, K. GPS interference testing: Lab, live, and LightSquared. *Inside GNSS*, 2011, **5**(4), 32-45.
  26. Dinesh, S.; Wan Mustafa, W.H.; Mohd Faudzi, M.; Kamarulzaman, M.; Nor Irza Shakhira, B.; Siti Robiah, A.; Norhayaty, Z.; Aliah, I.; Lim, B.T.; Arumugam, P.; Zainal Fitry, M.A.; Mohd Rizal, A.K.; Azlina, B. & Mohd Hasrol, H.M.Y. Evaluation of the effect of radio frequency interference (RFI) on Global Positioning System (GPS) receivers. *Def. S&T Tech. Bull.*, 2009, **2**(2), 115-29.
  27. Dinesh, S.; Wan Mustafa, W.H.; Mohd Faudzi, M.; Kamarulzaman, M.; Hasniza, H.; Nor Irza Shakhira, B.; Siti Robiah, A.; Shalini, S.; Jamilah, J.; Aliah, I.; Lim, B.T.; Zainal Fitry, M.A.; Mohd Rizal, A.K.; Azlina, B. & Mohd Hasrol, H.M.Y. Evaluation of power levels required by interference signals at various distances to jam the Global Positioning System (GPS) L1 coarse acquisition (C/A) signal. *Def. S&T Tech. Bull.*, 2010, **3**(1), 14-28.
  28. Dinesh, S.; Wan Mustafa, W.H.; Mohd Faudzi, M.; Kamarulzaman, M.; Hasniza, H.; Nor Irza Shakhira, B.; Siti Robiah, A.; Shalini, S.; Jamilah, J.; Aliah, I.; Lim, B.T.; Zainal Fitry, M.A.; Mohd Rizal, A.K.; Azlina, B. & Mohd Hasrol, H.M.Y. Evaluation of the effect of radio frequency interference (RFI) on Global Positioning System (GPS) accuracy. *Def. S&T Tech. Bull.*, 2010, **3**(2), 100-118.
  29. Aloï, D.N.; Alsliey, M. & Akos, D.M. A methodology for the evaluation of a GPS receiver performance in telematics applications. *IEEE T. Instrum. Meas.*, 2011, **56**(1), 11-24.
  30. Dinesh, S.; Wan Mustafa, W.H.; Mohd Faudzi, M.; Kamarulzaman, M.; Nor Irza Shakhira, B.; Siti Robiah, A.; Norhayaty, Z.; Aliah, I.; Lim, B.T.; Arumugam, P.; Zainal Fitry, M.A.; Mohd Rizal, A.K.; Azlina, B. & Mohd Hasrol, H.M.Y. The advantages of global navigation satellite systems (GNSS) receiver evaluation using GNSS simulators', *BUDI*, 2009, **Vol** (3), 6-10.
  31. Petrovski, I.; Townsend, B. & Ebinuma, T. Testing multi-GNSS equipment: Systems, simulators and the production pyramid. *Inside GNSS*, 2010, **5**(4), pp. 52-61.
  32. Kou, Y. & Zhang, H. Verification testing of a multi-GNSS RF signal simulator. *Inside GNSS*, 2011, **5**(4), 52-61.
  33. Garmin. GPSmap 60CS Owner's Manual. Garmin International Inc., Olathe, Kansas, 2004.
  34. Garmin. GPSmap 60CSx Owner's Manual. Garmin International Inc., Olathe, Kansas, 2007.
  35. Department of Defence (DOD). Global Positioning System Standard Positioning Service Performance Standard, Command, Control, Communications, and Intelligence. Department of Defence (DOD), Washington DC, 2001.
  36. US Army Corps of Engineers. NAVSTAR Global positioning system surveying engineer manual. EM 1110-1-1003, US Army Corps of Engineers (USACE), Washington DC, 2003.
  37. Aeroflex. Avionics GPSG-1000 GPS/Galileo portable positional simulator. Aeroflex Inc., Plainview, New York, 2010.
  38. Advantest. U3741/3751 Spectrum Analyzers. Advantest Corporation, Chiyoda-ku, Tokyo, 2009.
  39. IFR. 2023A/B, 2025 Signal Generators. IFR Americas Inc., Wichita, Kansas, 1999.
  40. Aaronia. Precompliance test antenna series HyperLOG® 60xxx: Span 680 MHz to 18 GHz. Aaronia AG, Strickscheid, Germany, 2009.
  41. CNET. GPSDiag 1.0. [http://download.cnet.com/GPSDiag/3000-2130\\_4-4951103.html](http://download.cnet.com/GPSDiag/3000-2130_4-4951103.html) [Assessed on 6 March 2010].
  42. A. Faridz, A.G.; M. Razali, M.Y. & W. Salwa, W.H. STRIDE's 3 meters EMC semi-anechoic chamber: Design considerations and compliance to standards. 2010 IEEE Asia-Pacific Conference on Applied Electromagnetics (APACE 2010), 9-11 November 2010, Tiara Beach Resort, Port Dickson, Negeri Sembilan, 2010.
  43. US Coast Guard (USCG). GPS NANUs, Almanacs, & Ops Advisories. <http://www.navcen.uscg.gov/?pageName=gpsAlmanacs> [Assessed on 6 January 2012].
  44. Trimble. Trimble's Planning Software. <http://www.trimble.com/planningsoftware.shtml> [Assessed on 17 November 2009].
  45. Huihui, W.; Xingqun, Z. & Yanhua, Z. Geometric dilution of precision for GPS single-point positioning based on four satellites. *J. Sys. Eng. Electr.*, 2008, **19**(5), 1058-1063.
  46. Petovello, M. Carrier-to-noise density and AI for INS / GPS integration. *Inside GNSS*, 2009, **4**(5), 20-29.

## Contributors



**Mr Dinesh Sathyamoorthy** received the BE (Comp. Engg.) and MEng (Comp. Engg.) from Multimedia University, Malaysia, in 2003 and 2006, respectively. He is pursuing his PhD (Electrical and Electronics Engineering) from Universiti Teknologi Petronas, Malaysia. Currently working as a Research Officer in the Science and Technology Research Institute of Defence (STRIDE), Ministry of Defence, Malaysia. His research interests include: Digital terrain modelling and digital image processing.



**Mr Mohd Faudzi Muhammad** received BE (Electrical Engineering) from University of Malaya, Malaysia, in 1994 and MSc from the National University of Malaysia, Malaysia, in 2005. Presently working as Head of Radar Branch, STRIDE, Ministry of Defence, Malaysia. His research interests include: Digital signal processing and neural networks.



**Mr Zainal Fitry M. Amin** received the Certificate in Electrical and Electronics Engineering from Ungku Omar Polytechnic, Malaysia. Currently working as a Senior Technician in the Radar Branch, STRIDE, Ministry of Defence, Malaysia. He has worked in a wide range of fields including: Electronics, communications, power systems, thermography, night vision systems, satellite navigation, and radar technologies.