

Defence Science Journal, Vol. 59, No. 3, May 2009, pp. 239-251
© 2009, DESIDOC

REVIEW PAPER

Seismic Response Control Systems for Structures

Nishant Kishore Rai¹, G.R. Reddy², S. Ramanujam¹, V. Venkatraj¹ and P. Agrawal¹,

¹Department Atomic Energy, Mumbai-400 094
²Bhabha Atomic Research Centre, Mumbai-400 078

ABSTRACT

Structures constructed in developing world are typically RC frames with masonry infill. These structures have little resistance for lateral loads caused by earthquake and wind. Even for adequately designed structures also, due to permissible deformation beyond elastic limits, failure of masonry causes severe loss of life and property. In the case of structures designed to sustain excessive deformation such as of defence establishments, functioning and serviceability of machines and equipment installed therein are adversely affected. This co-lateral damage may be reduced by adopting another design philosophy of structure response control. In this methodology, a supplementary damping device is incorporated in the primary structure, which absorbs most of the seismic energy imparted to it, restricting the structural response within serviceable limits. These devices may be passive, active, semi-active or hybrid types. Other than passive all options are technology-intensive and dependent on external energy source, not a favourable proposition for developing nations. Among all the passive devices, tuned liquid dampers (TLDs) promise to be most suitable. Here, existing overhead water tanks (OHWT) may be used as TLD with slight adjustment and modification. This method will be able to control the structural response without putting any extra load on the existing or newly-designed buildings. This paper reviews various types of dampers and discusses evolution of tuned liquid dampers. A method has also been proposed for incorporating TLDs in existing and new structures. This methodology may be very useful for structures of defence establishment which are scattered and remotely placed by location, housing important equipments sensitive to vibrations, as it is free from external power dependence and regular maintenance.

Keywords: Passive dampers, tuned sloshing water dampers (TSWD), tuned liquid dampers.

1. INTRODUCTION

Next to food and clothing, a secure shelter is the basic requirement of any civilised society. Buildings and structures make an important aspect of civilisation. Conventionally, structures have been designed to support vertical loads with very little resistance to lateral forces resulting due to dynamic loading conditions, e.g. earthquake, wind, and other induced vibrations.

In the recent past many natural disasters such as the 1971 earthquake in San Fernando, California; the 1989 Loma Prieta earthquake in San Francisco, California, the 1994 Northridge, California earthquake and the 1995 Kobe earthquake; 2001 Bhuj earthquake etc. have exposed the lateral weakness of structures to catastrophic effect¹.

The problem has been complicated manifold by the fast growth of population and urbanisation causing severe pressure on land occupancy, resulting in slimmer and taller structures with minimal footprint area. Floods, cyclone and earthquake are the types of natural disasters which may affect the structures adversely. Floods and cyclones have got longer duration and lesser impact as compared to earthquakes. Seismic forces due to an earthquake are of larger intensity and shorter duration. At the same time, suddenness and unpredictability of seismic events do not give any reaction time whatsoever.

However, in all kinds of disasters at the time of incipient failure, it is the lateral load-resisting mechanism that gives way to the collapse. So, it is obvious that an increase in lateral strength enhances structural performance in disastrous loading. Thus the designers and technocrats are persuaded to incorporate lateral loads also in design methodology. Conventional structural design philosophy considers static loads which is only one case of many dynamic loading conditions. Prevailing anti-seismic design methods rely on enhanced structural strength to withstand the effects of dynamic loads due to seismic events. In this method, buildings are designed for inertial forces and inter-storey drifts increasing from base to top (inverted triangle). In new constructions, the cost of this additional lateral strength is marginally high. In existing structures, strengthening for lateral loads is technology-intensive and inconvenient. But the extent of damage and losses incurred after a seismic event justify the adoption of these measures.

Although adequately designed, such structures will survive from collapse during violent earthquake, but damage to some structural elements and non-structural members is inevitable. This sure co-lateral damage in turn involves loss of building content in form of equipments, utilities and human life¹.

Received 17 August 2008

Concerned with the vulnerability of building contents against seismic event, even in non-collapsible and safe structures, designers have turned to another anti-seismic methodology of structural response control. In recent years, innovative means of enhancing structural functionality and safety against natural and man-made hazards have been in various stages of research, development, and application. These methods emphasise controlling response of the structure against accidental dynamic loadings to the safety and serviceability extent of the building, thereby increasing the occupancy comfort and minimising the loss of building content. Schematically structural control system tree is shown in Fig.1.

The problem of excessive response control is more pronounced for defence establishments as these are scattered

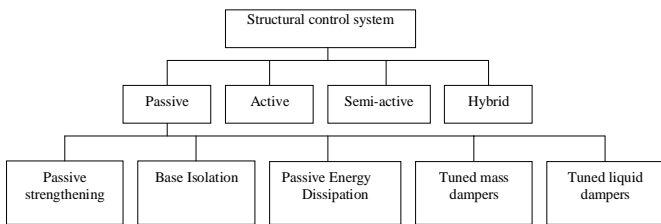

Figure 1. Schematic control system family.

and remotely located, house important and costly machines and equipments which are sensitive to vibration for normal functioning. Retrofitting or strengthening such structures with TLDs is an attractive and viable option as these are free from external energy dependence and regular maintenance. At the same time, these can easily be accommodated in existing structures and design parameters.

2. BASIC PRINCIPLE

Conventional anti-seismic approach relies on the inertial-resisting capacity of the structure against earthquakes through a combination of properties such as strength, deformability and energy absorption. Damping the inherent energy dissipation capacity of such structure is very low (< 5 %). Very small part of energy is dissipated through elastic behaviour. Under strong seismic excitation, these structures deform beyond the elastic limit, forming localised plastic hinges, resulting in localised damage, and thereby absorption of seismic energy.

An alternate energy-based earthquake mitigation approach considers energy distribution within the structure. Time-dependent energy conservation relationship of a seismic event may be presented as

$$E(t) = E_k(t) + E_s(t) + E_h(t) + E_d(t) \tag{1}$$

where

$E(t)$ = absolute energy input from earthquake motion,

$E_k(t)$ = absolute kinetic energy ,

$E_s(t)$ = elastic strain energy (recoverable),

$E_h(t)$ = irrecoverable energy dissipated through inelastic, viscous and hysteretic actions,

$E_d(t)$ = energy dissipated by supplemental damping

system, and

t = time.

In conventional structures $E_d(t)$ is not present, the input energy from ground motion acceleration is transformed into kinetic and strain energies which are absorbed or dissipated through heat. The inherent energy dissipation capacity of the structure tries to dissipate the seismic input energy by hysteretic actions, causing damages to the structure.

To avoid the structural damages, a supplemental energy dissipation system is added to the structure which absorbs major portion of input seismic energy, affecting all terms of Eqn. (1), and thereby response of structure is restricted within permissible limits. In supplemental energy dissipation methodology, the devices are incorporated either in base isolation system or in structural frames as dampers.

3. RESPONSE CONTROL SYSTEMS

3.1 Seismic Base Isolation

Seismic base isolation is an old design idea, and has wider applications with mature technology. It is based on the principle of decoupling the structure or part of it, or even of equipment placed in the structure, from the damaging effects of vibrations caused by seismic forces or ground accelerations. Seismic isolation aims:

- (i) to alter the fundamental frequency of the structure by shifting away from the dominant frequencies of earthquake ground motion (Fig. 2), and
- (ii) to control the displacement by addition of adequate amount of damping (Fig. 3).

Principle underlying seismic isolation may be explained by Figs 2 and 3. Period shift of structure reduces the acceleration transmitted to the isolated structure. In its effective form the structure approaches near stationary state whereas the supporting ground vibrates under excitation (Fig. 2). But increase in time period also increases the displacement. The displacement is controlled by inclusion of damping material in isolators such as lead [Figs 3 and 4(b)].

The base isolators inserted at founding level or at first floor level filter the horizontal components of the

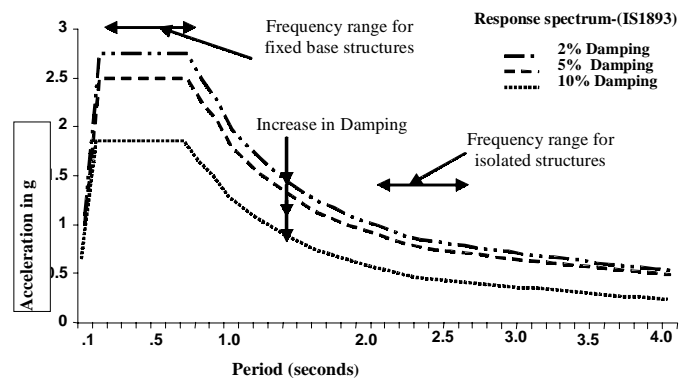

Figure 2. Reduced response due to frequency shift through base isolation.

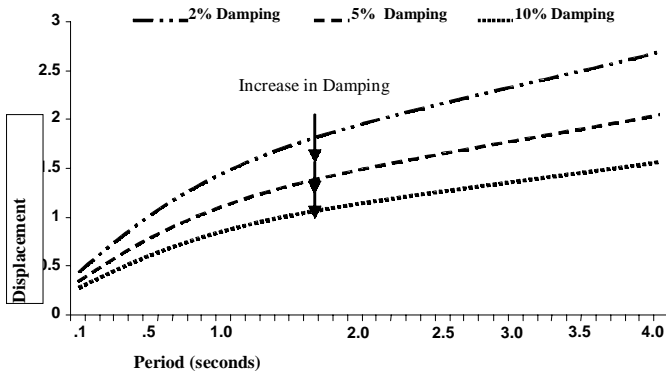

Figure 3. Reduced displacement due to increase in damping.

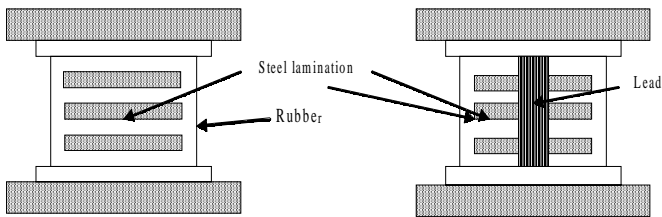

Figure 4. (a) Laminated rubber bearing and (b) Laminated Lead rubber.

seismic vibrations from soil, which are most dangerous when entering the structure. Seismic base isolation permits large lateral movement (from 20-40 cm in Italy, even 80 cm in California and Japan) of the structure but quite slowly (typically with periods of 2 s or more), and practically as a rigid body. This makes seismic isolation particularly adequate for the strategic and critically important constructions ensuring their functionality against severe seismic events^{2,3}.

The most commonly used seismic isolation devices are made of rubber called rubber bearings (RBs) as shown in Fig. 4(a). With, insertion of lead plugs (LRB or LPB) or the high damping rubber bearings (HDRB) a damping coefficient more than 10 per cent (Dolce *et al.* 2005) may be achieved⁴. Thereby the lateral movement is limited to a reasonable value as illustrated in Fig. 4(b).

In the USA a steel-teflon re-centring sliding system known as Friction Pendulum System (FPS) has been applied alone and performed satisfactorily⁵. The sliding isolation system is based on the concept of sliding friction. In India an experimental building with LPB has been constructed at Guwahati, as shown in Fig. 5, and its performance is being monitored for various studies⁶.

Important parameter to be considered in the choice of an isolation system, apart from its general ability of shifting the vibration period and adding damping to the structure is its capacity of self-centring, which is accomplished by the RBs and friction pendulums.

4. PASSIVE ENERGY DISSIPATION

All vibrating structures dissipate energy through internal stressing, rubbing, cracking, plastic deformation,



Figure 5. Prototype base isolated and conventional structure at gauhati and installation of base isolators (P.N. Dubey, 2007).

and so on. Methods of energy dissipation are very effective in reducing the structural response under dynamic loadings. This is achieved by incorporating passive energy dissipaters (PED) in primary structure.

Passive energy dissipation systems impart indirect damping to a structure through conversion of kinetic energy to heat, or by transferring of energy among vibrating modes. Passive energy dissipation systems encompass a range of materials and devices for enhancing damping, and can be used both for seismic hazard mitigation and for rehabilitation of aging or deficient structures. In general, such systems are characterised by their principle and mechanism of energy dissipation in the structural systems in which these are installed. Schematically, such systems with reference to Eqn.(1) may be presented as in Fig.7.

The energy conversion devices that involve direct dissipation of applied energy include visco-elastic, friction, viscous, lead, and steel and impact-type of dampers. These devices generally operate on principles such as frictional sliding, yielding of metals, and phase transformation in metals, deformation of visco-elastic (VE) solids or fluids⁷.

4.1 Metallic Yield Dampers

The idea of utilising added metallic energy dissipaters based on inelastic deformation of metals has been used

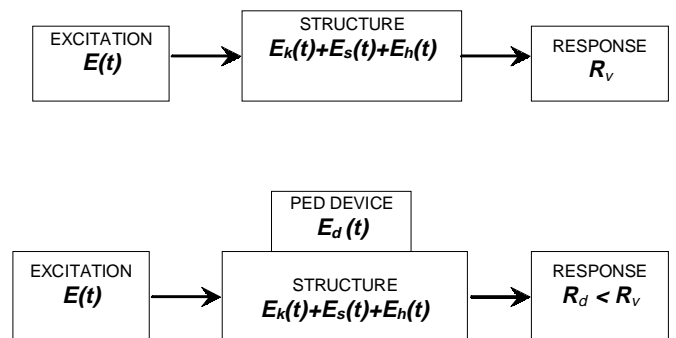

Figure 7. Structure with passive energy dissipating device.

effectively in structures for the dissipation of energy input from an earthquake⁸. These devices use mild steel plates with hourglass or triangular shapes so that yielding is spread almost uniformly throughout the material. One of the earliest applications of metallic yield damper (Fig. 8), is in a 29-storyed steel-frame building in Naples, Italy.

Other materials, such as lead and shaped-memory alloys, have also been considered and evaluated for their typical behaviour under loading.

Lead extrusion damper (LED) works on the principle of extrusion of lead. LED absorbs vibration energy by plastic deformation of lead, and thereby, mechanical energy

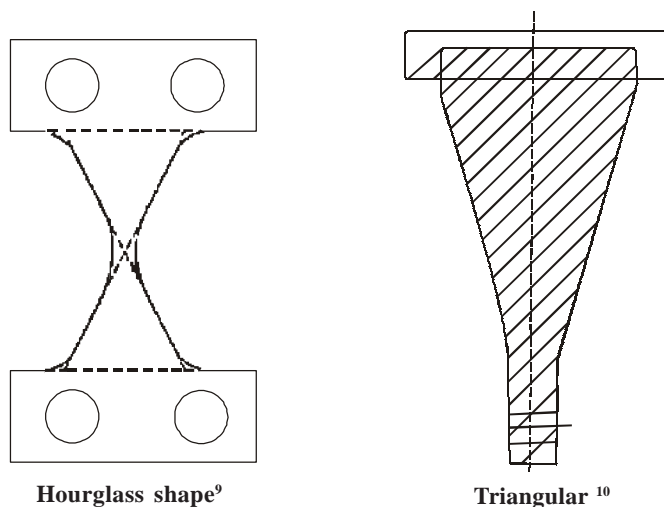

Figure 8. Metallic yield dampers.

is converted to heat. On being extruded, lead re-crystallises immediately and recovers to its original mechanical properties before next extrusion¹¹.

Shape memory alloys (SMA), have property of yielding repeatedly without sustaining any permanent deformation because the material undergoes reversible phase transformations as it deforms rather than inter-granular dislocations. The applied load induces crystal phase transformation that is reversed when the load is removed. Devices made from SMA are therefore self-centring^{12,13}.

The desirable features of these devices are stable hysteretic behaviour, low-cycle fatigue property, long-term reliability, and relative insensitivity to environmental temperature variations.

4.2 Friction Dampers

Friction provides an excellent mechanism for energy dissipation. Mechanism of solid friction developed between two surfaces with relative sliding provides the desired energy dissipation. Under severe loading conditions, these devices slip before yielding occurs in primary structure. The performance of such dampers is not significantly affected by loading amplitude, frequency, the number of loading cycles. Pall x-braced friction devices and their variations have been installed in several buildings as a retrofit and new constructions as well. In India, it has

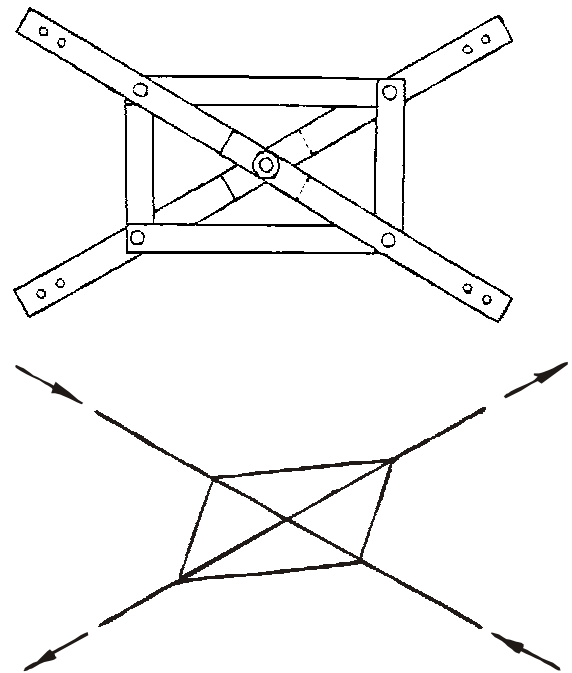

Figure 9. (a) Pall friction damper and (b) deformed configurations of Pall friction dampers¹⁶.

been installed in Gardenia Towers South City, Gurgaon¹⁴. The concept has also been used successfully to reduce the response of equipment and piping systems of complicated installations under effect of vibration loads¹⁵.

4.3 Visco-elastic Dampers

The visco-elastic (VE) dampers are considered to be the most promising and have been installed in several buildings all over the world. It consists of layers of VE material (copolymers or glassy substances) bonded with steel plates (Fig.10). Vibration energy is dissipated through shear deformation of VE material sandwiched between steel plates. This system has been successfully applied in the following:

- (i) World Trade Centre in New York (1969)
- (ii) The Columbia Sea First Building in Seattle (1982)
- (iii) The Two Union Square Building in Seattle (1988)
- (iv) The 13-story steel frame Santa Clara Country Building in San Jose, California (1994)
- (v) The Chien-Tan railroad station roof in Taipei, Taiwan (1994)
- (vi) A navy-owned three-story lightly reinforced concrete building in San Diego¹⁷ (1997).

4.4 Viscous Fluid Dampers (VFD)

The viscous fluid dampers are widely used in military and aerospace industry. Now they are being used for civil engineering structures also. A VF damper typically consists of a piston housed in silicon compound filled cylinder. The piston contains small orifices through which passage of viscous fluid takes place. Thus energy is dissipated through orificing by the movement of piston in highly

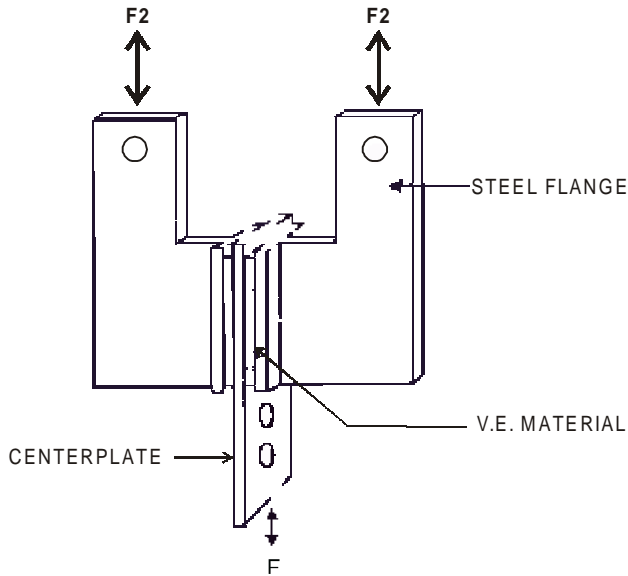

Figure 10. Visco-elastic damper.

viscous fluid. Another form was developed by Sumitomo Construction Co Ltd, Tokyo, Japan, consisting of a plate moving in a thin steel case filled with highly viscous fluid¹⁸.

Some important application of VFDs to civil engineering structures are as follows:

- (i) One kilometer long bridge weighing 25,000 tons in Italy, protected by viscous silicon gel dampers at each abutment (weight: 2 ton, length: 2 m, stroke: 500 mm) (1991) and
- (ii) A 78.6 m high, 14-storeyed building at the centre of Shizouka City, Japan, where viscous walls have been used to control the structural response²⁰.

The other popular concept of passive response control of structure is by transferring of energy among vibrating modes by coupling an auxiliary inertial system to primary structure. Such systems include tuned mass dampers (TMDs) and tuned liquid dampers (TLDs), which include sloshing dampers (TSDs) and liquid column dampers (TLCDs).

These types of dampers impart indirect damping to the structure by modifying the frequency response of the structural system, thereby reducing the structural response. The auxiliary mass contained in the dampers is tuned at the natural frequency of the primary structure. The attached auxiliary mass will resonate out of phase with the primary structural motion. The energy is absorbed

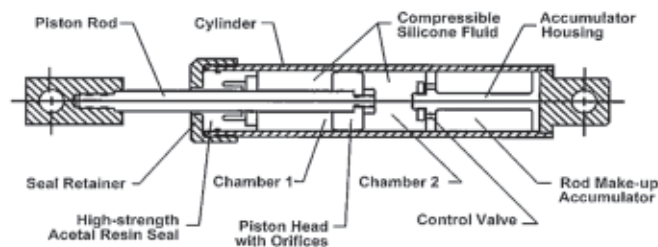

Figure 11. Taylor devices fluid damper¹⁹.

by damper inertia force acting on primary structure, thereby modifying the resultant structural response within the acceptable limits.

5. CONTROL DEVICES

5.1 Active Control Systems

Active control devices reduce the structural response by means of resistance offered through an external energy source. Active control systems are reaction based real time force delivery devices integrated with real-time processing evaluators / controllers and sensors within the structure. These act simultaneously with the hazardous excitation to provide balancing force mechanism and thereby enhanced structural behaviour for improved service and safety. Schematically such systems may be presented in Fig.12.

Structural motion can be controlled by an active mass damper (AMD) or an active bracing system (ABS). The AMDs are configured such that the active mass is either in a sliding or pendulum mode. In the case of a pendulum mode, multiple pendulums can be used to account for long periods. The mass ratio in the case of AMDs is lower as compared to passive systems. For AMDs with a lower secondary mass, more control force is required. The actuators used in active systems are hydraulic or use

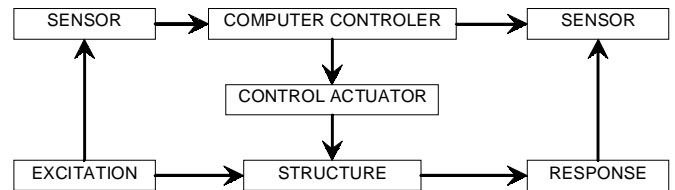

Figure 12. Structure with active control.

AC servomotor systems. There exist many other active configurations in practical application²¹.

5.2 Semi-Active Control systems

The semi-active systems have been developed to overcome the shortcomings of large space requirement of passive systems and high energy demands of active system. In this approach a passive device is installed in the structure and its properties are tuned to the optimum level as per the real time excitation signals generated by structure. In these types of systems energy demand is much less as compared to active systems. At the same time installation is easy and workable in comparison of passive systems. Schematically such systems may be presented as in Fig.13.

These types of systems have been very well understood, experimented and implemented in tuned liquid column dampers (TLCD), tuned mass dampers (TMD). Other semi-active systems like the variable orifice, ER and MR type of energy dissipaters have recently been studied and have shown great potential.

One of the recent and promising semi-active control

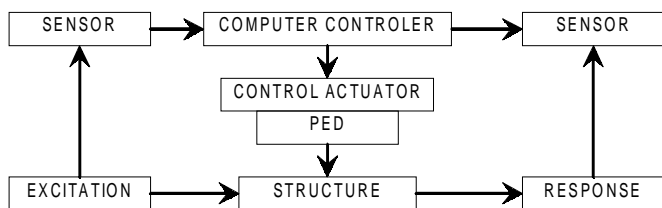

Figure 13. Structure with semi-active control.

devices is the magneto-rheological (MR) damper. It overcomes the expenses and technical difficulties associated with other types of semi-active devices. The development of MR fluids and devices can be credited to Jacob Rabinow²² at the US National Bureau of Standards in the late 1940s. The MR fluids respond to an applied magnetic field with a dramatic change in rheological behaviour. The outstanding characteristic of these fluids is their ability to reversibly change from free flowing, linear viscous liquids to semi-solids having controllable yield strength in milliseconds when exposed to a magnetic field. Through simulations and laboratory model experiments, it has been shown that a MR damper, used in connection with the proposed acceleration feedback strategies, may perform well under seismic and other dynamic load conditions²³.

5.3 Hybrid Control Systems

Structural control systems are not generic in nature, implying that any one type of control system may not be most effective measure in all types of dynamic loading conditions. Hence, applying more than one type of structural control methodology to the structures is thought to be more effective. In this concept, a combination of more than one type of systems acts simultaneously to restrict the structural response. Schematically, such systems may be presented as in Fig.14.

Passive systems have limited ability to respond to higher frequency components of applied loads like earthquakes. A hybrid system may be utilised to overcome this shortcoming. In this system PED acts along with active control system.

Since a part of the structural control is accomplished by passive system, less active control is required. In the case of a tuned mess damper, the building may be equipped with a passive secondary mass damper system and a tertiary small mass connected to the secondary mass with a spring, damper, and actuator. The secondary (passive) system is set in motion by the active tertiary mass, thus, more

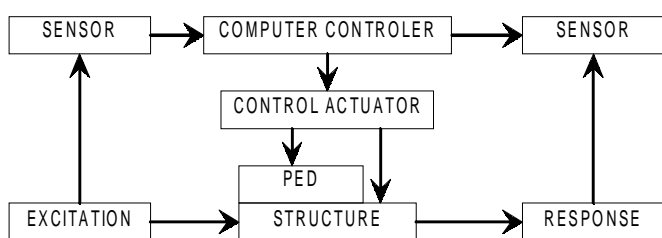

Figure 14. Structure with hybrid control.

effective and efficient structural control is achieved. An example of such a system is known as “Duox,” and has been installed in the Ando Nighikicho Building in Tokyo²⁴ (T.K. Datta, 2003). It is a 14 storey rigid frame steel building with double basement levels. An 18 t, TMD, is placed on the roof of the building and thereupon two-directional 2 t AMD is placed. Duox system operates on the principle that active control enhances the performance of TMD and in case of active control system failure, the passive TMD will provide some control of response.

Another example is the systems installed in the Mitsubishi Juko Building, Yokohama, and in the NTT Kuredo Motomach Building, Hiroshima. Here tuned system has a multiple-stepped pendulum and an ac servomotor is used for its control²⁵. The system is effective against low-level vibrations, but works equally well to counteract more serious swaying caused by strong winds.

Alternatively, a roller pendulum and active structural response control produce a compact, lightweight, high-

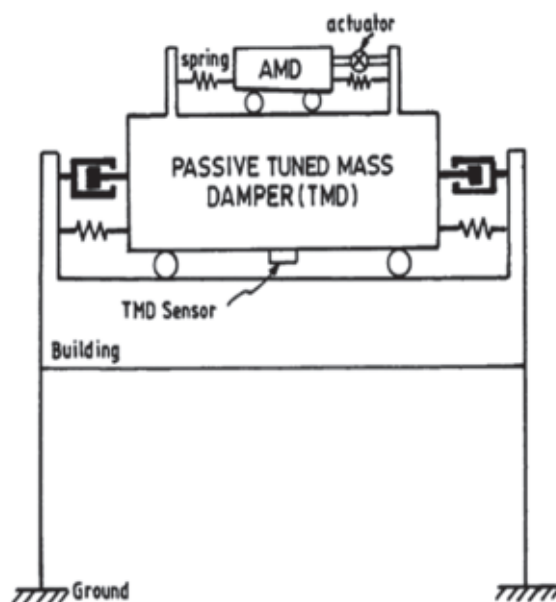

Figure 15. Hybrid control with Duox system²⁴.

performance system. Such a device is installed in the Shinjuku Park Tower in Tokyo²⁵. This system has the flexibility of an adjustable damper period from 3.7 to 5.8 s, and three units are installed for serviceability enhancement. Other current applications of an AMD or a hybrid system installed at the Kansai New International Airport Tower, Osaka²⁵(two-pendulum type AMDs).

Various means to manage the structural response are summarized in Table 1.

6. DEVELOPING NATIONS PERSPECTIVE- EARTHQUAKE PREPAREDNESS

From a developing nations perspective, most of their urban areas are prone to one or the other type of natural disaster. Earthquakes of recent past have shown the fury

and havoc of disaster caused by them. Exposure of Ahmedabad to Bhuj Earthquake¹ had given an eye-opening example of vulnerability of such urban infra-structures against a natural calamity. Moreover, most of Indian metros and walled cities are sitting on the line- of attack of seismic activities. Any future seismic event in these locations has the capacity of putting the development engine in reverse gear. The situation is equally alarming for other nations also.

Hence apart from making new structure safe, strengthening and re-qualification of the existing structures for earthquake loading is a major concern. Most of the structures of urban centres of developing world built in the past 30 years, are of 4 to 6 storey height and made of ordinary moment resisting concrete frames with masonry in-filled walls. These structures are generally deficient

as most suitable and adoptable option for such conditions.

Of all the passive energy dissipation systems, Liquid dampers containing water as damping mass promises to be a very attractive and feasible structural control device for seismic and wind response control of the existing structures. All the urban structures do house an overhead water tank on its roof which is an ideal location for TLD. Thus, the liquid dampers offer a more convenient utilisation of space and weight, where, the building water supply tank can be used as an energy absorber also (Fig.16).

6.1 Tuned Liquid Dampers

Tuned liquid dampers currently being applied for structural control are tuned sloshing water damper (TSWD) and tuned liquid column damper (TLCD) (Fig.17). A TSWD

Table 1. Means to suppress structural responses of buildings

Means	Type	Method & Aim	Remarks
Architectural planning	Passive	Improving load distribution and reducing eccentric force coefficient.	Regular and symmetrical planning.
Structural Design	Passive	Increasing stiffness or natural frequency to reduce deformation	Bracing Walls, Thick Members, Increased Material Costs.
		Provide a continuous and smooth stress path.	Proper alignment of load transfer members.
Auxiliary Damping Device	Passive	Addition of materials with energy dissipative properties, increasing building damping ratio	MYD, LD, FD, VED, VD,
		Adding auxiliary mass system to alter the primary modal mass participation.	TMD, TLD
	Active	Generating control force using real time excitation feed back to minimize response	AMD
	Semi-active	Instantaneous tuning of device using real time excitation feed back to enhance the effectiveness during seismic activity.	AVS
	Hybrid	Combination of Passive and active devices.	HMD

MYD: Metallic yield Damper; LD: Lead Damper; FD: Friction Damper; VED: Visco-Elastic Damper; VD: Viscous Damper; TMD: Tuned Mass Damper; TLD: Tuned Liquid Damper; AMD: Active Mass Damper; HMD: Hybrid Mass Damper; AVS: Active Variable Stiffness.

to resist lateral loads due to earthquake.

Also in new structures made with earthquake loading considerations, masonry infill is major component of inertia mass which is very brittle as compared to structural components. In the seismic eventuality the masonry in-fill fails and causes heavy collateral damage to the building and its content. Making these structures survive strong seismic event is of utmost importance for sustainability of development. Hence structural response control is a ‘must adopt’ requirement for the developing nations.

As is clear from the previous descriptions, active, semi-active or hybrid systems are technology-intensive, power-dependent, and expensive, hence not a very friendly and convenient option for developing nations. All these considerations make passive energy dissipation systems

is the simplest form of TLD. It consists of a rigid vessel holding a given mass of liquid (water) placed at the top of the building. The water contained in the vessel is free to slosh causing energy absorption and damping. The vessel and its content are tuned to slosh at the natural frequency of the primary structure, thereby readjusting its vibration energy to restrict the structural response. In this form TSWD is analogous to TMD (Fig.18). But unlike a TMD, a TSWD has an amplitude-dependent transfer function that is further complicated by the nonlinearity of the sloshing process and wave-breaking of the sloshing liquid.

The major source of energy dissipation is due to viscous action in the boundary layers of the free surface, tank wall and bottom surfaces and the sloshing motion of free water surface. The sloshing liquid absorbs structural energy and

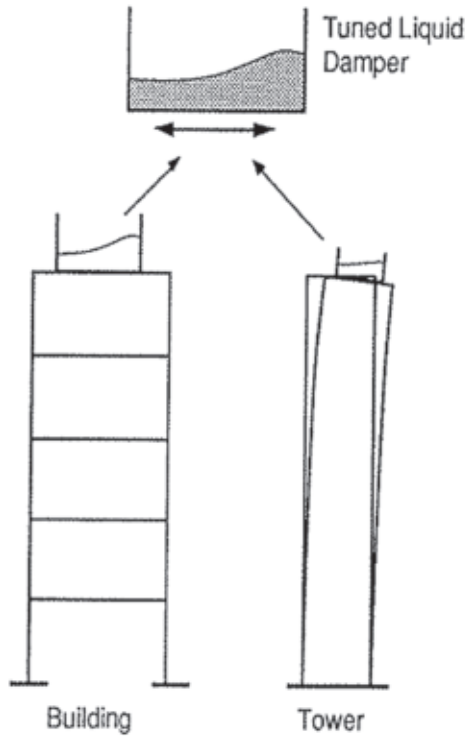

Figure 16. TLD on a building or tower (not to scale).

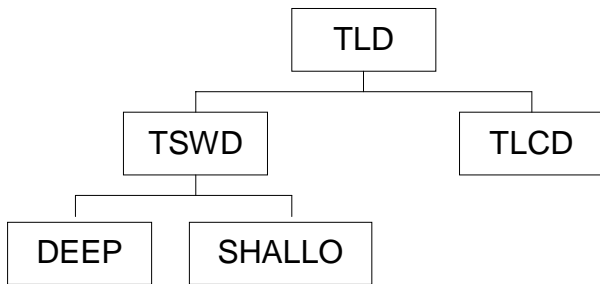

Figure 17. Schematic TLD family.

dissipates it by means of the viscous action of the liquid. Based on the geometry TSWD may further be classified as shallow and deep TSWD. This classification is based on the ratio of water depth-to-length of the tank in the direction of motion. A ratio of 0.15 or less is considered to be a shallow TSWD.

In deep TSWD, a large portion of water does not participate in damping action as it moves monolithically with the tank body. It is referred, as impulsive water content of the tank. Shallow TSWD uses maximum of its water in energy absorption action, resulting in response control.

Many shapes, configurations, and arrangements have been studied in TSWD. Various shapes considered for analytical and experimental studies are annular tanks (nutation damper)²⁶, rectangular²⁷, conical tanks²⁸. Primarily TSWDs are passive in nature, with no control on the damping characteristics of the damper. This results in non-optimal performance on other than design amplitudes of excitation.

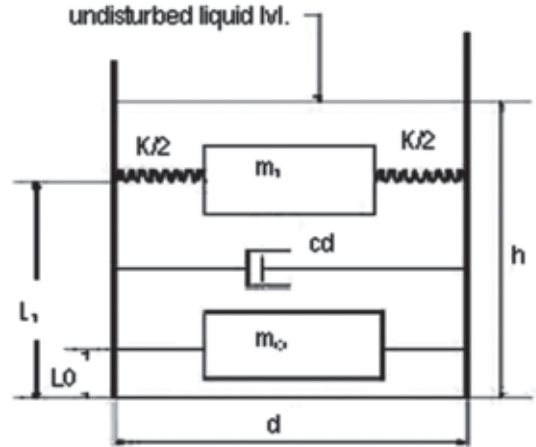

Figure 18. Analogical TMD model for linear sloshing.

In order to overcome this limitation, semi-active and active systems were proposed²⁹. A baffled tank was studied with baffle placed inside the liquid container. The orientation of the baffle was changed by external energy source (based on real time excitation feedback), thus changing the effective length of the damper, thereby making it useful as a variable-stiffness damper³⁰.

In a tuned liquid column damper (TLCD), motion of the column of liquid in a U-tube-like container that mitigates the vibrating forces acting on the structure. A constricted flow through a valve or an orifice or multiple orifices causes energy dissipation in the oscillating liquid³¹. The damping value of a TLCD is also sensitive to the level of excitation amplitude. Other versions of liquid dampers exist, including inertial pump dampers. By applying controlled air pressure to a TLCD configuration, systems can be tailored to offer more flexibility in the tuning frequency without changing the water column height.

6.1.1 Evolution of Tuned Liquid Dampers

Initial application of TLD dates back to 1862, when W.Froude conceptualised and proposed two interconnected

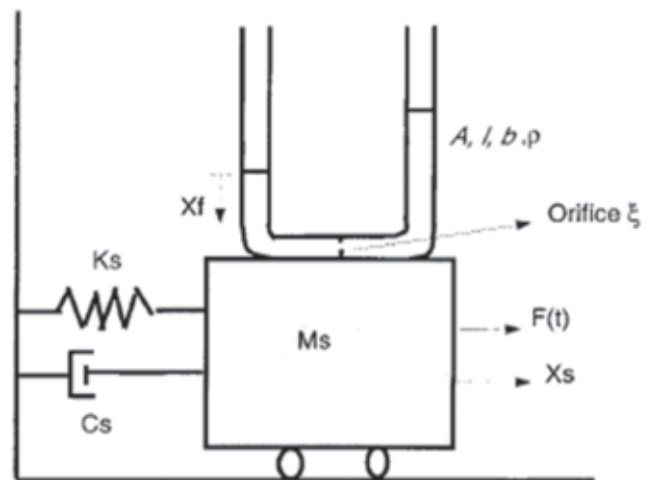

Figure 19. Schematic TLCD on a single degree of freedom system¹⁷.

tanks to reduce the rolling component of ship motion. The concept was further improved by tuning the frequency of motion of two interconnected tanks to the rolling frequency of the ship to control the rolling component of the ship. The actual device for practical use was developed and put into application³² by P.Watts in 1880. A U- shaped tank as roll stabiliser was proposed by H.Frahm in 1911 as shown in Fig. 20. Since 1950 similar anti-roll tanks have found a wider application in commercial vessels. The modern ship stabilisers are capable of both heel and roll controls using watertank.

The sloshing motion of the liquids in storage tanks on fixed-offshore structures affects its dynamic response. In 1978 Vandiver and Mitome had been able to reduce the platform response using the tanks already required for storage of water, fuel, mud or crude oil as dynamic vibration absorbers with a modified tank geometry, avoiding any additional equipment³³.

For floating offshore structures like tension leg platforms (TLPs), a passive open bottom tank system relying upon the oscillations of the water columns in the tanks was successfully considered³⁴. In 1987 Huse has studied free-surface damping tanks to reduce resonant heave, roll and pitch motions of semi-submersibles and other offshore structures. The damping tanks situated at the water line were kept open to the sea through suitable restrictions.

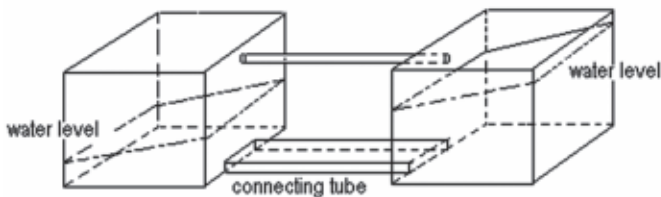

Figure 20. Interconnected tanks as rolling stabiliser.

Kareem and Sun, Modi, *et al.* were first to propose TLDs for structural applications in 1987 in the area of satellite applications, and were followed by Fujino³⁵*et al.*, these dampers were referred to as nutation dampers.

By 1989 Sakai, *et al.* proposed a new type of liquid damper which was termed as a tuned liquid column damper (TLCD) and proposed its application for cable-stayed bridge towers. TLCDs were studied for wind excited structures by Tamura³⁶ *et al.* and Balendra³⁷ *et al.*, effectiveness of TLCDs against pitching motion has been studied by Xue³⁸ *et al.* The practical application of these dampers in structures like Gold Tower Chiba, Shin Yokohoma Prince Hotel and Nagasaki and Tokyo Airport Tower has shown the response reduction up to 70 per cent at a wind speed of 20 m/s. Studies were also carried at for determining certain optimal characteristics of these passive devices by Gao³⁹ *et al.*; Chang and Hsu⁴⁰. The performance of TLCDs for seismic applications has been studied by Won⁴¹ *et al.* and Sadek⁴² *et al.* It has been observed that for a given mass ratio, large modal damping in the first mode of vibration may be achieved

by tuning for that frequency.

Most of the earlier studies on passive versions of TLCDs had no control on the damping characteristics. The damper was designed to be optimal at design amplitudes of excitation but was non-optimal at other amplitudes of excitation. This limitation was overcome in semi-active and active systems proposed by Kareem²⁹; Haroun⁴³ *et al.*, and Abe⁴⁴ *et al.* In 1994 a system was proposed for TLDs by Lou³⁰ *et al.* in which a baffle was placed inside the liquid damper, the orientation of the baffle changed the effective length of the tank, thereby making it useful as a variable-stiffness damper.

Concept of multiple mass dampers (MMDs), with natural frequencies distributed around the natural frequency of the primary structure to be controlled, has been studied extensively by Yamaguchi and Harnpornchai⁴⁵; Kline and Kareem^{29,46}, the concept has been extended to TLCDs also⁴⁷. Such systems lead to smaller sizes of TLCDs. This improvement had positive effect on their construction, installation, and maintenance, and also offers a range of possible spatial distributions in the structure. The tuned multiple spatially distributed dampers, offer a significant advantage over a single damper since multiple dampers, when strategically located, are more effective in mitigating the motions of buildings and other structures undergoing complex motions. Multiple damper configurations with slightly detuned systems have shown to be more effective than a single isolated damper. For the same total mass, the equivalent damping introduced to the system by multiple dampers (5 in place of 1) is substantially more than that due to a single damper⁴⁶. Furthermore, the optimal damping is also much lower than a single damper, which makes it more attractive for liquid dampers.

6.1.2 Application of Tuned Liquid Dampers

Advantages attached with tuned liquid dampers have led to their adoptability world over and these were successfully installed on many important installations structures. Some of the important are listed in Table 2.

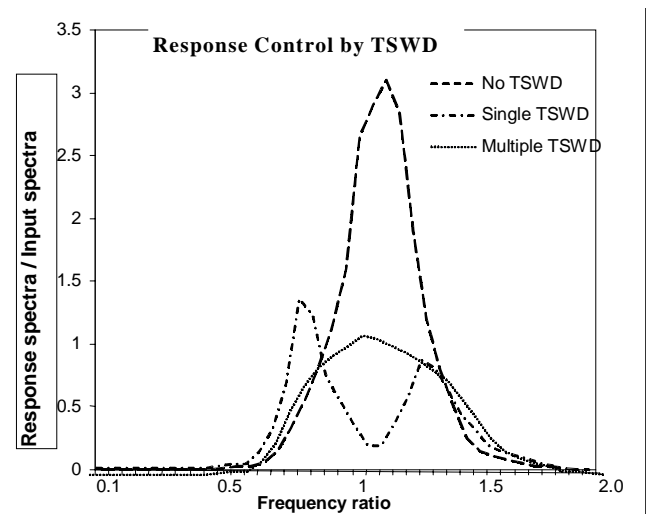

Figure 21. Response control concept through TSWD.

6.2 Structural Control Methodology with TSWD for Existing Structures

Research has shown a better and greater potential for structural control through strategically placed multiple liquid dampers. Most of the urban Indian structures already have a water tank for their routine requirement placed on their roof (Fig.16).

The existing overhead tank may be tuned to the primary structural frequency by ensuring the minimum depth of water as per existing geometry of the tank (usually 0.3 times the lateral dimensions). This can be achieved by altering the height of outlet in the existing tank thus increasing the dead storage to the extent that minimum height of water to the tuned level is always available. This increase in dead storage may result in reduction of live storage capacity which may be augmented by providing additional tanks at strategic locations, connected to the water supply loop of the building. These additional tanks may not be tuned optimally but may be distributed and placed at strategic locations to have maximum controlling effect, as schematically shown in Fig.20.

This type of arrangement is possible for most of the existing structures with minimum disturbance to the occupation and at a reasonably affordable cost. The rearrangement of the water tanks will affect the structural performance of the primary structure by more reasonable and equitable load and damping distribution appropriately compatible with the stiffness.

Added advantage of decentralised water distribution system with lesser energy and maintenance demand due

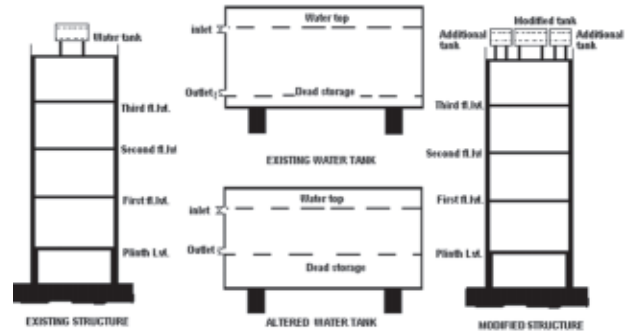

Figure 22. Schematic modification of existing buildings with water tank as multiple TSWD.

to modification should also be considered while calculating cost effectiveness of this methodology.

However this simple methodology needs to address design implementation and reliability issues in field experiences along with cost effectiveness. To arrive at a functionally reliable modification resume for any existing structure, it should be based on sound theoretical and practical aspects of application. The prevalent methods of study and application for new anti-seismic methodologies are (i) numerical modelling and analysis, and (ii) experiments on scaled models. Both these methods have their own advantages and disadvantages. A hybrid method involving both the above mentioned methods may be adopted for developing a comprehensive rehabilitation procedure for the existing structures. The steps involved in the process are enumerated below:

Step1. Parametric definition of the primary structure vis-a-vis physical condition of structure, loading, occupancy

Table 2. Structures with installed Tuned liquid dampers

Name and Type of Host Structure	City/ Country	Type and number of dampers	Year of installation	Frequency, Wt., Damping
Nagasaki Airport Tower(42 m)	Nagasaki, Japan	25 tuned liquid dampers (circular sloshing type)	1987	1.07 Hz 1 t (approx.)
Yokohama Marine Tower (105 m)	Yokohama, Japan	39 tuned liquid damper (circular sloshing type)	1987	0.55 Hz 1.6 t
Gold Tower (136 m)	Udatsu, Japan	16 tuned liquid dampers (rectangular unidirectional type)	1988	0.42 Hz 9.6 t
Shin-Yokohama Prince Hotel (149m)	Yokohama, Japan	30 tuned liquid dampers (circular sloshing type)	1991	0.31 Hz 83.5 t
Mount Wellington Broadcasting Tower (lattice tower, 104 m)	Hobart, Australia	80 tuned liquid dampers (circular sloshing type)	1992	0.7 Hz 0.6 t
TYG Building (159 m)	Atsugi, Japan	720 tuned liquid dampers (double donut type)	1992	0.53 Hz 18.2 t
Narita Airport Tower (87 m)	Narita, Japan	tuned liquid dampers (circular sloshing type)	1993	1.3 Hz 16.5 t
Haneda Airport Tower (178 m)	Tokyo, Japan	Tuned liquid dampers (circular sloshing type)	1993	0.77 Hz 21 t

and utility.

Step2. Numerical modelling of the primary structure for determining the worst response generating load condition.

Step3. Making a physical scaled model of the primary structure with similar dynamic properties and experimenting by subjecting it to various loadings for determining the worst response generating load condition.

Step4. Making a numerically scaled model of the primary structure equivalent to physical model compatible with the experimental results, by varying the stiffness and damping for the primary mode of vibration.

Step5. Modifying the numerical model of the primary structure in accordance with the scaled model dynamic properties.

Step6. Modifying the physical scaled model of the primary structure by resizing the over head water tank and installing additional water tanks located at strategic positions as per occupancy requirement.

Step7. Subjecting the scaled physical model the modified primary structure to the predetermined worst loading and quantifying the response reduction for different combinations of additional water tank locations.

Step8. Determining an envelop location and geometry for additional water tanks having maximum response reduction.

This procedure involves numerical as well as experimental steps for benchmarking the problem and appropriating the solution. It tries to define the dynamic properties of the primary structures and evolves a solution which is compatible with physical as well as numerical assumptions and idealizations.

7. CONCLUSION

The study aims to provide an assessment of the state-of-the-art and state-of-the-practice of the exciting, and still evolving, technology seismic response control systems. Also included are some basic concepts, the types of structural control systems being used and deployed, and their advantages and limitations in the context of seismic design and retrofit of civil engineering structures. In the specific context of developing nations like India, suitability of tuned liquid dampers has been highlighted for the rehabilitation and re-qualification of the existing structures. This concept is of advantage for heritage structures where much scope is not available for modification and additional retrofitting. Similarly for scattered and remotely located defence structures equipped with valuable machines and equipments, this methodology is vital as it does not require any additional space, external energy and structural / architectural modification. Economics of the methodology is within the acceptable domains for most of the structures as it improves the routine functionality of the host primary structure along with improvement in anti-seismic performances.

Apparently, TLD is a very attractive proposition for structural response control during a seismic event, but

the major limitations hindering the application of TLDs are: (i) the physical phenomenon of water sloshing is not fully understood. Effects of wave breaking in the process of sloshing may be a potential source of analytical and design error; and (ii) prevalent methods for TLD design involve many approximations, which should be addressed through rigorous analytical and experimental studies.

The major advantages which may be attributed to the tuned liquid dampers are: (i) Low initial cost; (ii) Low or no maintenance cost; (iii) Ease of frequency tuning; (iv). No limit for vibration amplitude and; (v). Easy applicability for existing buildings; (vi) No mass or weight addition to the structure as water required for building purposes may also serve the damping requirement. Additionally, the water contained in the damper body will be available for various uses under distress, and otherwise.

REFERENCES

1. Jain, S.K., *et al.* Preliminary observations on the origin and effects of the January 26, 2001 Bhuj (Gujrat, India) Earthquake, EERI Special Earthquake Report. *EERI Newslett.*, April 2001.
2. Fujita, T. Seismic isolation and response control of nuclear and non-nuclear structures, Proceedings of the 11th International Conference of Structural Mechanics in Reactor Technology, Tokyo, 1991.
3. Martelli, A. & Forni, M. (editors), Isolation, energy dissipation and control of vibrations of structures. Proceedings of the International Post-SMiRT Conference Seminar, Capri, Italy, August 21-23, 1993, ENEA for GLIS, Bologna, Italy, 1994.
4. Dolce, M.; Martelli, A. & Panza G.F. Let us protect from earthquakes - The Modern technologies and Methodologies and the New Seismic Code, 2nd edition, 21mo Secolo, Milan, Italy, 2005.
5. Jangid, R.S. & Datta, T.K. Seismic behaviour of base isolated building - A State of the Art Review. *J. Struc. Buildings, Proc. Inst. Civil Engrs. (London)*, 1995, **110**, 186-203.
6. Dubey, P.N.; Reddy, G.R.; Deb, S.K.; Vaje, K.K.; Ghosh, A.K. & Kushwaha, H.S. Performance of base isolated RCC framed building under actual earthquake. Proceedings of the International Workshop on Earthquake Hazards and Mitigation, Guwahati, India, 2007.
7. Satish Kumar, K.; Muthumani, K.; Gopalakrishnan, N.; SivaramaSarma, B.; Reddy, G.R. & Parulekar, Y.M. Seismic response reduction of structure using elastoplastic passive energy dissipation, *ASET J.*, 2002, **39**(3), 85-94
8. Kelly, J.M.; Skinner, R.I. & Heine, A.J. Mechanisms of energy absorption in special devices for use in earthquake-resistant structures bull. *N.Z. Nat. Soc. Earthq. Eng.*, 1972, **5**(3).
9. Whittaker, A.S.; Bertero, V.V.; Thompson, C.L. & Alonso, L.J. Seismic testing of steel plate energy dissipation devices, *Earthq. Spectra*, 1991, **7**(4), EERI.
10. Tsai, K.C.; Chen, H.W.; Hong, C.P. & y Su, Y.F. Design

- of steel triangular plate energy absorbers for seismic resistance construction, *Earthq. Spectra*, 1993, **9**, 505-28.
11. Parulekar, Y.M.; Reddy, G.R.; Vaze, K.K. & Kushwaha, H.S. Lead extrusion damper for reducing seismic response of coolant channel assembly. *Nucl. Engg. Desi. J.*, 2004, **227**(2), 175-83.
 12. Aiken, I.D.; Nims, D.K. & Kelly, J.M. Comparative study of four passive energy dissipation systems, *Bull N.Z. Nat. Soc. Earthq. Eng.*, 1992, **25**(3).
 13. Sreekala, R. & Muthumani, K. *et al.* Passive seismic response control using devices made of shape memory alloys. Proceedings of 8th Technical Programme Discussion Meeting, 2006, pp. 93-103.
 14. Chandra, R. Friction-dampers for seismic control of La Gardenia towers south city, Gurgaon, India. Paper 2008, 12WCEE, New Zealand, 2000.
 15. Bakre, S.V.; Jangid, R.S. & Reddy, G.R. Response of piping system on friction support to bi-directional excitation. *Nucl. Eng. Desi.*, 2006, **237**, 124-36, .
 16. Pall, A.S. & Marsh, C. Seismic response of friction damped braced frames. *Jnl of the Str. Div.*, 1982, **108**(ST6), ASCE, New York.
 17. Yalla, S.K. & Kareem, A. Modeling tuned liquid dampers as sloshing-slamming dampers. Proceedings of 10ICWE, Copenhagen, Denmark, 1999.
 18. Arima, F.; Miyazaki, M.; Tanaka, H. & Yamazaki, Y. A study on buildings with large damping using viscous damping walls. Proceedings, 9WCEE, Tokyo/ Kyoto, Japan, Aug. 1988.
 19. Constantinou, M.C.; Symans, M.D.; Tsepelas, P. & Taylor, D.P. Fluid viscous dampers in application of seismic energy dissipation and seismic isolation. Proceedings of ATC-17-1 Seminar of Seismic Isolation. Passive Energy Dissipation, and Active Control, 1993, **2**, 581-91.
 20. Miyazaki, M. & Mitsusaka. Design of a building with 20% or greater damping, Proceedings, 10WCEE, Madrid, Spain. 1992.
 21. Fujita, T. (editor) Seismic isolation, energy dissipation and active vibration control of structures - Kobe, Japan, June 11-16, 2005. Proceedings of the 9th World Seminar, JAVIT, Tokyo, Japan, (to be published).
 22. Rabinow, J. The Magnetic Fluid Clutch, *AIEE Trans.*, 1948, **61**, 1308-115. National Bureau of Standards Technical News Bulletin.
 23. Spencer, B.F. Jr.; Yang, G.; Carlson, J.D. & Sain, M.K. Smart dampers for seismic protection of structures: A full-scale study. Proceedings of the Second World Conference on Structural Control (2WCSC), Kyoto, Japan, June 28 - July 1, 1998.
 24. Datta, T.K. A state-of-the-art review on active control of structures. 22nd ISET Annual Lecture, 2003.
 25. Soong, T.T. & Spencer, B.F. Supplemental energy dissipation: state-of-the-art and state of the practice -Engineering Structures, 2002, **24**,
 26. Modi, V.J. & Welt, F. Vibration control using nutation dampers, international conference on flow induced vibrations, London, England. 1987, 369-76.
 27. Miyata, T.; Yamada, H. & Saitoh, Y. Feasibility study of the sloshing damper system using rectangular containers, *JSCE, J. Structural Engineering*, 1989, **35A**, pp. 553-60. (Japanese)
 28. Casciati, Fabio.; De Stefano, Alessandro.; Matta, Emiliano. "Simulating a conical tuned liquid damper" Simulation Modelling Practice and Theory. 2003, **11**, 353-70.
 29. Kareem, A. The next generation of tuned liquid dampers, Proceedings of the 1st World Conference on Structural Control, Los Angeles, 1994.
 30. Lou, Y.K.; Lutes, L.D. & Li, J.J. Active tuned liquid damper for structural control, Proceedings of the First World Conference on Wind Engineering, 1994, **1**, Los Angeles.
 31. Sakai, F., *et al.* Tuned liquid column damper - new type device for suppression of building vibrations, Proceedings Int. Conf. on High-Rise Buildings, Nanjing, China. 1989.
 32. Den Hartog, J.P. Two degree of freedom, mechanical vibrations, 4th edition, McGraw-Hill, New York, 1956, pp. 79-120.
 33. Vandiver, J. K. & Mitome, S. Effect of liquid storage tanks on the dynamic response of offshore platforms, Dynamic Analysis of Offshore Structures: Recent Developments, 1978.
 34. Patel, M. H. & Witz, J.A., On improvements to the design of tensioned buoyant platforms, Behaviour of Offshore Structures, 1985, 563-73.
 35. Fujino, Y., *et al.* Tuned liquid dampers (TLD) for suppressing horizontal motions of structures, *J. Eng. Mech.*, 1992, **101**(10).
 36. Tamura, Y. Recent topics of vibration control for wind-induced vibrations of buildings, English translation of a paper by Tamura in Japanese in Proceedings of the 2nd Colloquium on Vibration Control of Structures, JSCE, 1993.
 37. Balendra, T.; Wang, C.M. & Cheong, H.F. Effectiveness of tuned liquid column dampers for vibration control of towers, *Eng. Struc.*, 1995, **17**(9), 668-75
 38. Xue, S.M.; Ko, J.M. & Xu, Y.L. Tuned liquid column damper for suppressing pitching motion of structures, *Eng. Struc.*, 2000, **23**, 1538-551.
 39. Gao, H.; Kwok, K.C.S. & Samali, B. Optimisation of tuned liquid column dampers, *Eng. Struc.*, 1997, **19**, 476-86
 40. Chang, C.C. & Hsu, C.T. Control performance of Liquid column vibration absorber, *Eng. Struc.*, 1999, **20**(7), 580-86
 41. Won, A.Y.J.; Pires, J.A. & Haroun, M.A. Stochastic seismic performance evaluation of tuned liquid column dampers, *Earthq. Engg. and Struc. Dyn.*, 1996, **25**, 1259-274.
 42. Sadek, F.; Mohraz, B. & Lew, H.S. Single- and multiple-tuned liquid column dampers for seismic applications,

- Earthq. Engg. and Struc. Dyn.*, 1998, **27**, 439-63.
43. Haroun, M.A. & Pires J.A. Active orifice control in Hybrid liquid column dampers, Proceedings of the First World Conference on Wind Engineering, (1994),**I**, Los Angeles
 44. Abe, M.; Kimura, S. & Fujino, Y. Control laws for semi-active tuned liquid column damper with variable orifice opening, 2nd Int. Workshop on Structural Control, Hong Kong, 1996.
 45. Yamaguchi, H. & Harnpornchai, N. Fundamental characteristics of multiple tuned mass dampers for suppressing harmonically forced oscillation, *J. Earthq. Engg. and Struc. Dyn.*, 1993, **22**.
 46. Kline, S. & Kareem A. Performance of multiple mass dampers under random loading, *J. Struc. Eng.*, ASCE, 1995, **121**(2).
 47. Gao, H.; Kwok, K.C.S. & Samali, B. Characteristics of multiple tuned liquid column dampers in suppressing structural vibration, *Engg. Struc.*, 1999, **21**, 16-331

Contributors

Mr Nishant Kishore Rai obtained his MTech (Foundation Engg), BSc Engg (Civil). He has worked with UP Samaj Kalyan Nirman Nigam Ltd, and Department of Atomic Energy. He has planned, designed, and executed different type of civil engineering structures, ranging from small span bridges to overhead tanks, and low cost housing to high rise buildings. His areas of expertise include: Technology intensive construction solutions, comprehensive project planning and management, structural design, innovative approach.



Dr G.R. Reddy obtained his BE from Bangalore University, MTech from IIT, Bombay, and PhD in Earthquake Engg from TMU, Tokyo. He is working as Scientific Officer H at Reactor Safety Division, Bhabha Atomic Research Centre, since 1984, in the area of structural dynamics and earthquake engineering. He has analysed reactor structures and equipments. His areas of research include: modeling techniques of complex structures, structure-equipment interaction due to earthquakes, stochastic methods of analysis, dynamic substructure techniques.