

77

APPROXIMATE IDENTITY OPERATOR IN LINEAR CONTINUOUS
AND SAMPLED-DATA SERVOMECHANISMS

535

by

ANDRE JEAN RAULT
Ingenieur ARTS ET METIERS
PARIS, 1962

A MASTER'S REPORT
submitted in partial fulfillment of the
requirements for the degree

MASTER OF SCIENCE

Department of Electrical Engineering

KANSAS STATE UNIVERSITY
Manhattan, Kansas

1964

Approved by:

CHalijak

Major Professor

LD
2668
R4
1964
R245
C.2

TABLE OF CONTENTS

INTRODUCTION.	1
LINEAR SERVO DESIGN - APPROXIMATION TO THE IDENTITY.	1
1. King's Criterion and an Algorithm.	1
2. King's Criterion in Ordinary Servo Design.	3
a. Approximate Identity of First Order.	3
b. Approximate Identity of Second Order.	3
c. Approximate Identity of Third Order.	5
d. Linear Adaptive Servo Structure.	8
PERFORMANCE IMPROVEMENT.	12
1. Existence of an Iterative Process.	12
a. Newton Process.	15
b. Halley Process.	16
c. General Approximate Identity Improvement Process.	20
d. Interrelationship of Newton and Halley Processes.	23
TRANSIENT BEHAVIOR.	25
1. Properties of the Newton Process.	25
2. Distribution of Poles and Zeros.	28
3. Comparison between the Given Method and the Usual Optimization Criteria.	35
SAMPLED-DATA SERVOS.	40
1. Error Coefficient Theory. Approximate Identity for Sampled-Data Systems.	43
2. Approximate Identity and Sampled-Data Servo Design.	45
3. Equivalence of Approximate Identity and Zero Error Coefficient.	49
4. Performance Improvement.	52

CONCLUSION. 57

ACKNOWLEDGMENT. 58

REFERENCES. 59

APPENDIX A - A Zero Error Coefficient Algorithm for Continuous Systems. . 61

APPENDIX B - Sampled-Data Approximate Annihilator. 64

INTRODUCTION

Usual servo design procedure primarily emphasizes stability analysis and then improves servo performances by use of compensation techniques. In this study, the admissibility problem is considered first; this permits the servo to be viewed as an approximate identity operator. Improvement of the approximate identity is obtained using Newton (1) and Halley (2) processes. Transient behavior is analyzed from the pole and zero aspect and a root-locus-like technique enables prediction of performances of higher order systems generated by a Newton process.

A parallel to King's (3) zero error coefficient theory in linear continuous system design can be constructed for linear sampled-data systems. Therefore, the concept of approximate identity is readily extended to sampled-data systems. Admissibility and performance improvement are then accomplished in a similar manner to the continuous systems.

LINEAR SERVO DESIGN - APPROXIMATION TO THE IDENTITY

1. King's Criterion and an Algorithm*

The first problem in feedback control theory is to find a one-input, one-output system such that for a given input, the output is asymptotically equal to the input signal. Such a device is called a servo for the given input. It should be stressed that a servo can be attained only for a specific input or set of inputs. Not every linear feedback device possesses the servo property! It is convenient to designate the test which distinguishes general feedback devices (controllers) from servos by special nomenclature.

Definition: A feedback device is admissible into the servo class if it satisfies King's criterion.

* A proof for this algorithm is given in appendix A.

King's (3) criterion applies only to polynomial inputs and requires that the first p successive error coefficients of the transfer function be zero. Error coefficients of the transfer function of a feedback device are exhibited in Appendix A. A simple admissibility algorithm can be found for this criterion. If the transfer function of a feedback control system can be written in the form

$$T(s) = \frac{a_0 + a_1s + a_2s^2 + \dots + a_ms^m}{b_0 + b_1s + b_2s^2 + \dots + b_ns^n} \quad (1)$$

where m and n are integers with $m < n$, then the admissibility algorithm states: if $T(s)$ is a stable transfer function, a servo will have no position, velocity, acceleration and in general no up to $(d/dt)^p$ error if $T(0) = 1$ and $a_k = b_k$ for $k = 1, 2, 3, \dots, p$ with $p \leq m$.

For instance, if

$$T(s) = \frac{a + bs}{a + bs + cs^2} \quad (2)$$

then the system having this transfer function is a position and velocity servo because it has neither position nor velocity steady-state errors for inputs of the type $\alpha + \beta t$. Furthermore, this transfer function will be called an approximate identity operator. If the first p successive pairs of coefficients of s^k are equal, then the order of the approximate identity is p . It will be convenient to denote an approximate identity of order p by $\hat{\uparrow}_p$. A k^{th} order approximate identity operator will be realized by a device having a transfer function of the form

$$T(s) = \frac{a_0 + a_1s + a_2s^2 + \dots + a_{k-1}s^{k-1}}{a_0 + a_1s + a_2s^2 + \dots + a_{k-1}s^{k-1} + a_k s^k} \quad (3)$$

and noted as $\hat{\uparrow}_k$.

2. King's Criterion in Ordinary Servo Design.

Since the first goal is to design a stable device which will follow the given input as closely as possible, King's concept will be applied systematically to ordinary servo design.

Notation: The Laplace transform of a time function x will be denoted as \bar{x} .

(a) The Approximate Identity of First Order. It corresponds to a no-position error servo. A typical realization as shown in Fig. 1 has the control equation

$$\bar{y} = (k/s) (\bar{x} - \bar{y})$$

whose solution is $\bar{y} = [k/(k + s)] \bar{x}$ (4)

The solution can be written symbolically, $\bar{y} = \uparrow_1 \bar{x}$.

(b) The Approximate Identity of Second Order. It corresponds to the no-position and no-velocity error servo. The following typical realization shows that a velocity servo can be achieved: (a) without integrator elements contrary to accepted beliefs; (b) without unity in feedback link. It is an undetermined coefficient method.

Consider the block diagram Fig. 2, the closed loop transfer function is

$$T(s) = \frac{a/(1 + bs)}{1 + (a/a)/(1 + \beta s)(1 + bs)}$$

$$T(s) = \frac{a + a\beta s}{1 + (a/a) + (\beta + b) s + \beta bs^2} \quad (5)$$

The coefficients of the feedback path transfer function are determined so that the overall transfer function $T(s)$ be a second order approximate identity operator. This yields

$$\begin{cases} a = 1 + (a/a) \\ a\beta = \beta + b \end{cases} \quad \begin{cases} \alpha = a/(a - 1) \\ \beta = b/(a - 1) \end{cases} \quad (6)$$

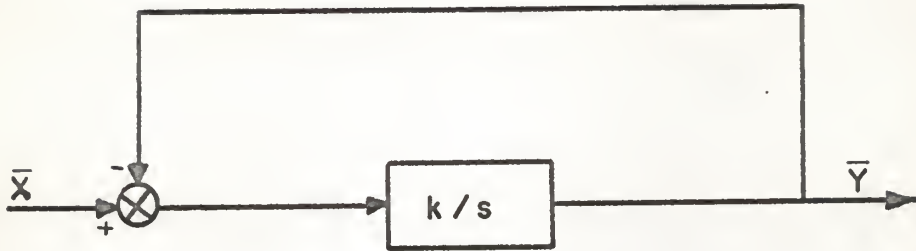

FIG.1 First Order Approximate Identity

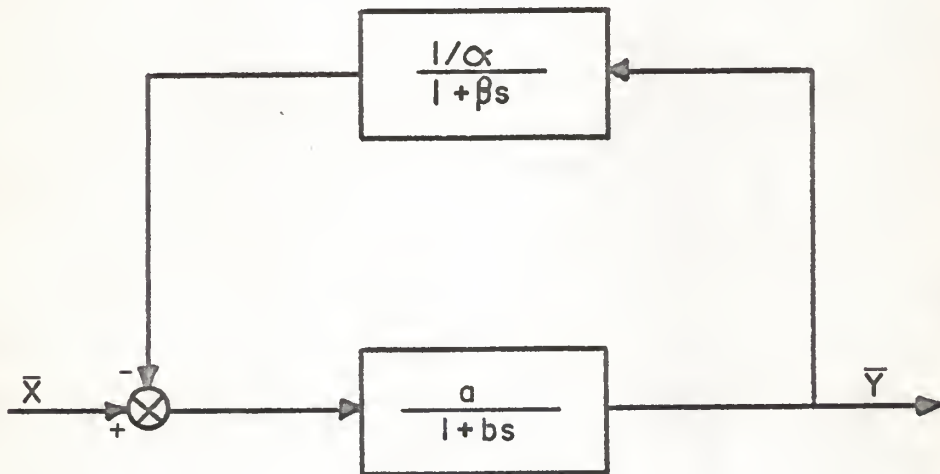

FIG.2 Second Order Approximate Identity

Under the condition $a > 1$, we obtain the relation

$$\bar{y} = \frac{a + \frac{ab}{a-1}s}{a + \frac{ab}{a-1}s + \frac{b^2}{a-1}s^2} \quad \bar{x} = \uparrow_2 \bar{x} \quad (7)$$

This second order system structure is particularly interesting as an analog simulation can show. This system's damping is controlled uniquely by the coefficient a , while b controls the speed. A simulation of this second order system where " a " was held constant and " b " varied gave the unit step and unit velocity response curves shown in Fig. 3 and 4. These curves exemplify the previous statement since the three transfer function outputs have the same damping but different rise time.

(c) The Third Order Approximate Identity. It corresponds to a no constant-position, no constant-velocity and no constant-acceleration errors system. Its realization can be attained by an undetermined coefficient process.

The block diagram will be of the form shown in Fig. 5. The reduced form of the closed loop transfer function is

$$T(s) = \frac{a + a\beta s + a\gamma s^2}{(1 + a/\alpha) + (b + \beta)s + (\gamma + b\beta)s^2 + b\gamma s^3} \quad (8)$$

Identification of parameters α, β, γ yields

$$\begin{aligned} \alpha &= a/(a-1) \\ \beta &= b/(a-1) \\ \gamma &= b^2/(a-1)^2 \end{aligned} \quad (9)$$

Thus, under the condition $a > 1$, the system response is

$$\bar{y} = \uparrow_3 \bar{x} \quad (10)$$

Note that in this form, parameters a and b are still to be determined.

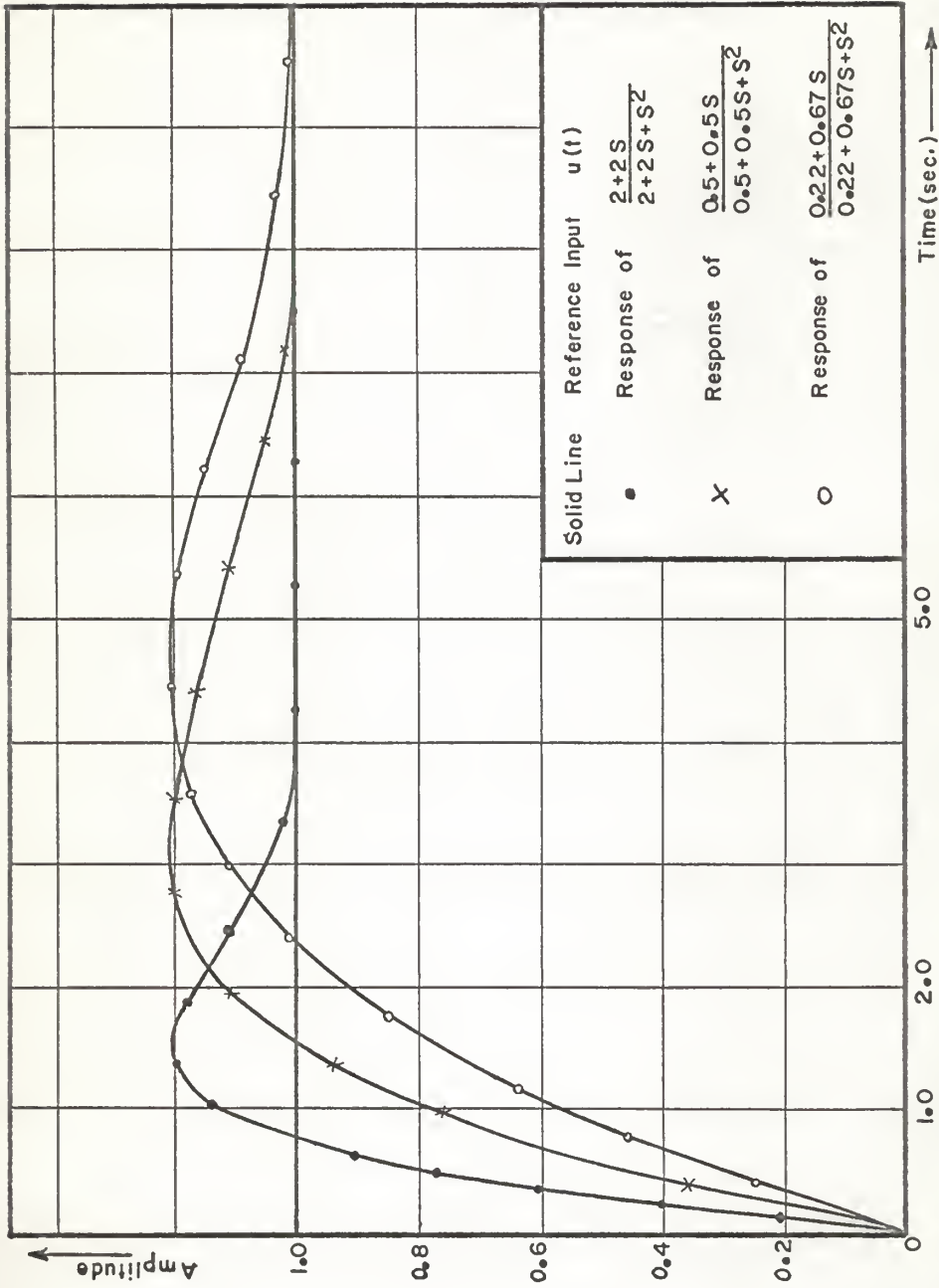

FIG. 3 2nd Order Approximate Identity Response to a Unit Step Input

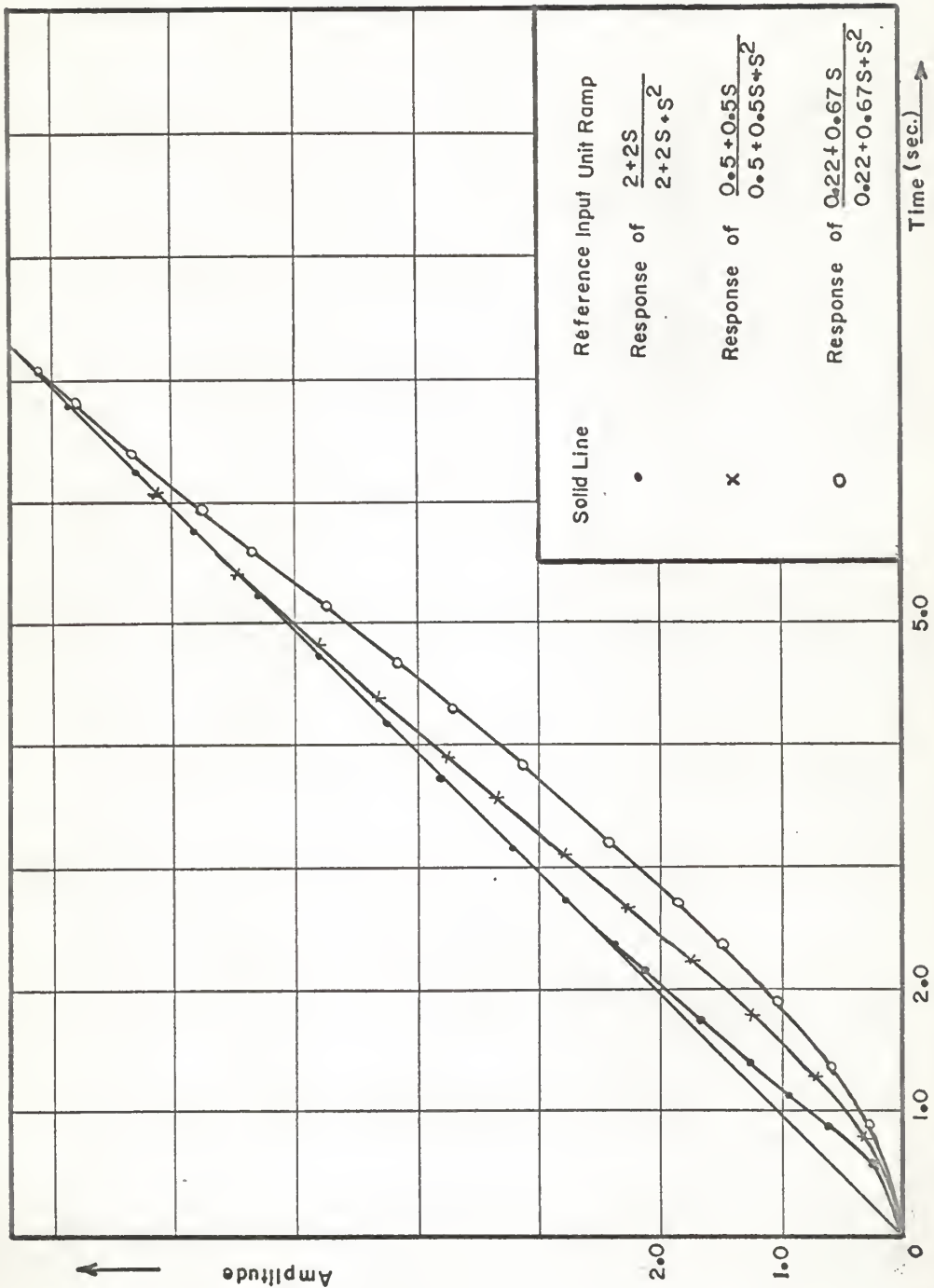

FIG. 4 2nd Order Approximate Identity - Response to Unit Ramp Input

Performance improvement constraints will force attention to the transient response.

Using the admissibility criterion for servo design, it has been shown how servos to unit step, unit velocity and unit acceleration inputs are realized systematically and without integrators.

(d) Application of King's Criterion to the "Linear Adaptive" Servo Structure. The "linear adaptive" servo structure of Fig. 6 has been established by Campbell (4) at Cornell Aeronautical laboratories. Later, Carlson (5) used it as a basic extension of approximate identities to the realization of a model transfer function, $M(s)$. A is the controlled element which must follow the behavior of the model M , through the help of the feedback element B which is more or less empirically adjusted by the usual procedure. The control equation of the system is

$$\bar{y} = A \bar{x} - B(\bar{y} - M\bar{x}) \quad (11)$$

The system response is

$$\bar{y} = (1 + BM) \frac{A}{1 + AB} \bar{x} = \begin{bmatrix} 1 + BM \\ 1 + BA \end{bmatrix} \begin{bmatrix} A \\ M \end{bmatrix} M\bar{x} \quad (12)$$

This "adaptive" control system structure corresponds to a canonical feedback system to which a filtering by the transfer function $(1 + BM)$ has been added; on the other hand one can adopt the viewpoint that the goal is to make $\begin{bmatrix} 1 + BM \\ 1 + BA \end{bmatrix} \begin{bmatrix} A \\ M \end{bmatrix}$ an approximate identity and therefore the structure should be called a controller model.

Let us consider the following problem: Suppose a given system has the overall transfer function of an approximate identity of the first order; it is desired to realize a servo to a velocity signal. This problem can be solved by the "linear adaptive" structure: the analyzed system is the controlled element; the model transfer function is 1; the goal is servo design;

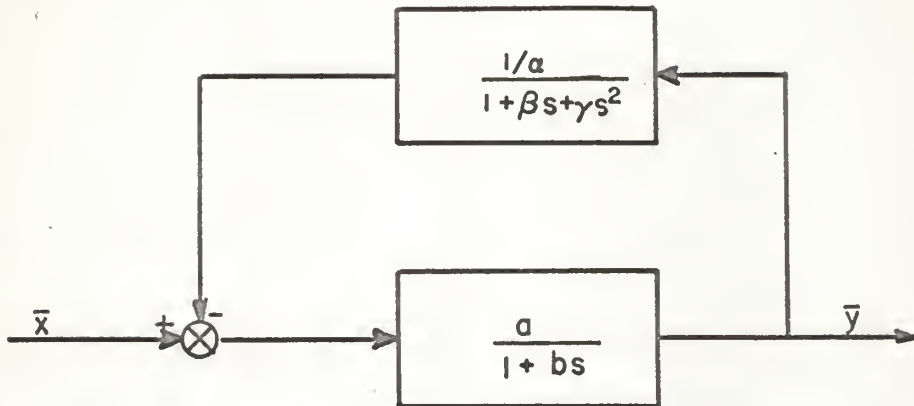

FIG-5 Third Order Approximate Identity

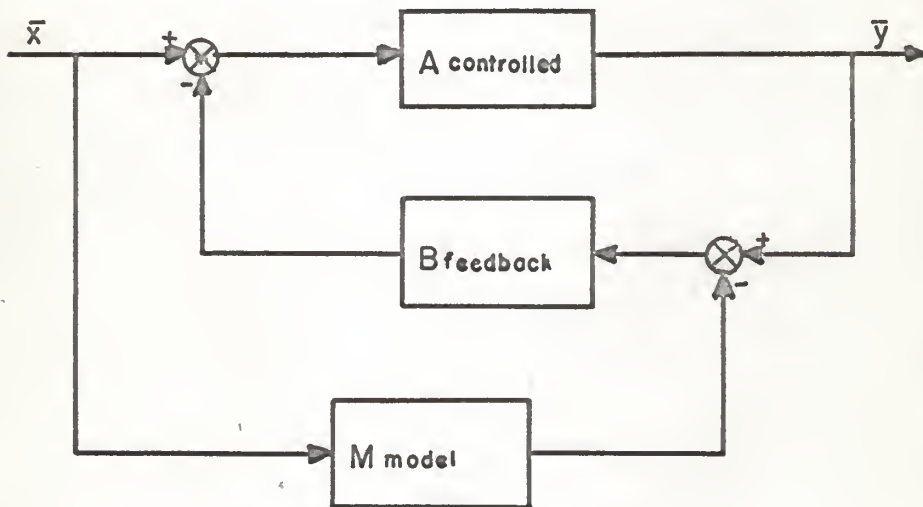

FIG-6 Canonical Form of Feedback Controller ('Linear Adaptive' Servo)

What should be the form of the feedback transfer function B? The controlled element has the form

$$A = 1/(1 + as)$$

The transfer function of the "adaptive" structure

$$\bar{y} = (1 + B) \frac{1/(1 + as)}{1 + B/(1 + as)} \bar{x} \quad (13)$$

reduced to the form

$$\bar{y} = [(1 + B)/(1 + B + as)] \bar{x} \quad (14)$$

where by using an elementary integrator in feedback: $B = \alpha/s$, a second order approximate identity

$$\bar{y} = [(\alpha + s)/(\alpha + s + as^2)] \bar{x} = \uparrow_2 \bar{x} \quad (15)$$

is obtained

Figure 7 summarizes the use of the "linear adaptive" servo structure for increasing the order of an approximate identity. Generalization of this property is going to be made.

Consider a system with an approximate identity of $(n - 1)$ th order

$$A(s) = \frac{\sum_{k=0}^{n-1} a_k s^k}{\sum_{k=0}^n a_k s^k} \quad \text{with } a_0 = 1 \quad (16)$$

It will be shown that an integrator in the feedback loop of the adaptive servo structure whose solution is

$$\bar{y} = (1 + B) \frac{\sum_{k=0}^{n-1} a_k s^k \sum_{k=0}^n a_k s^k}{1 + B \sum_{k=0}^{n-1} a_k s^k \sum_{k=0}^n a_k s^k} \quad (17)$$

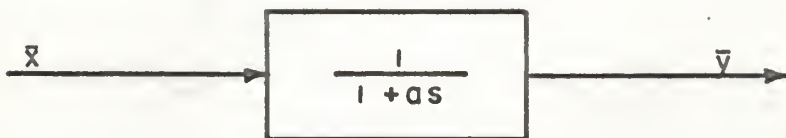

Initial Approximate Identity

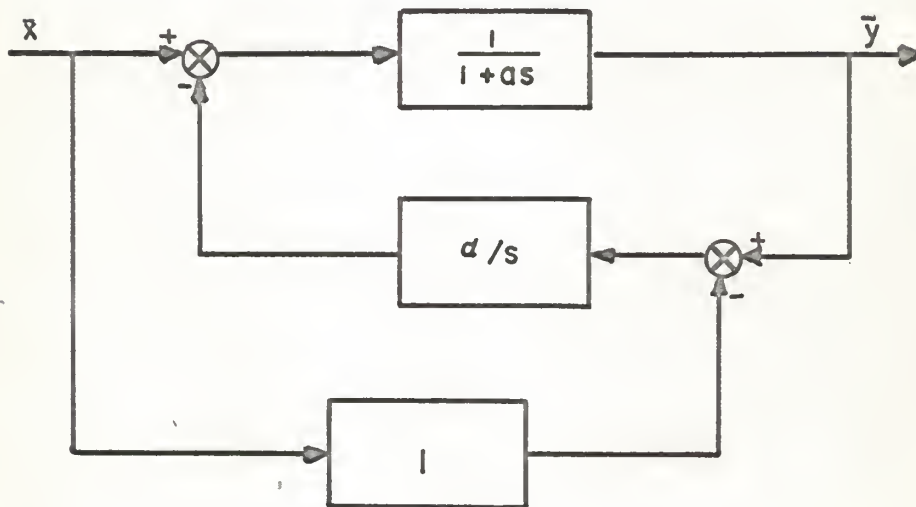

FIG-7 First Iterate of Initial Approximate Identity

generates the n^{th} order approximate identity

$$\bar{y} = \frac{\alpha + \sum_{k=0}^{n-1} (a_{k-1} + a_k) s^k + a_{n-1} s^n}{\alpha + \sum_{k=1}^{n-1} (a_{k-1} + a_k) s^k + a_{n-1} s^n + a_n s^{n+1}} \bar{x} \quad (18)$$

if $B = \alpha/s$.

So the "linear adaptive" servo structure gives a systematic solution to the problem of generating the next order approximate identity; the only required element for this process is an integrator. Note that the coefficient of the integrator term is an arbitrary term which can be used for adjusting the stability of the system.

In the previous pages, it has been shown how flexible servo design procedure can be by use of King's criterion. The concept of approximate identity operator was introduced clearly and this concept will be used as a fundamental tool in a future study of multivariable servos.

However, before going any further, a general physical realization of the approximate identity is going to be derived which employs iterative processes for approximate identity operators.

PERFORMANCE IMPROVEMENT

1. Existence of an Iterative Process.

The first system considered is the common integrator with unity feedback servo of Fig. 8; it is known that it will perform an approximate identity of the first order because

$$\bar{y} = \left[1/(1 + \tau s) \right] \bar{x} \quad (19)$$

For simplicity of notation, normalized variables will be used; any change

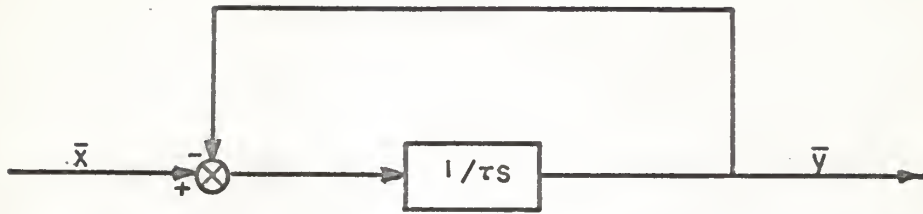

FIG.8 First Order Approximate Identity

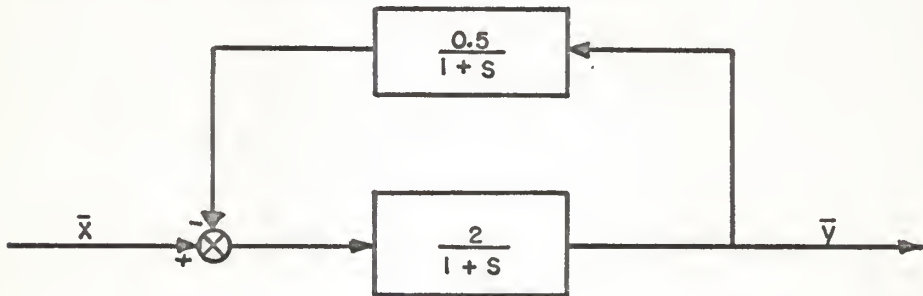

FIG.9 First Improvement of Initial Approximate Identity

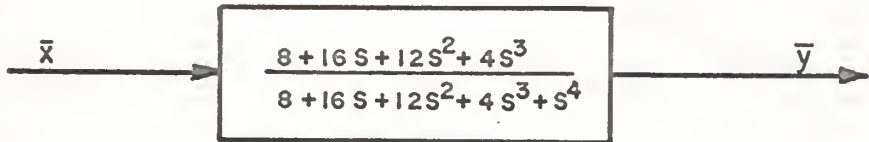
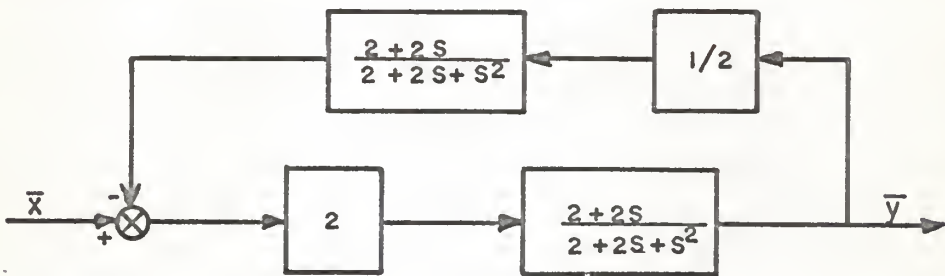

FIG.10 Second Improvement of Initial Approximate Identity
which is Integrator Free

can be initiated by replacing s by τs . The first order system is

$$\bar{y} = [1/(1 + s)] \bar{x} = \hat{1}_1 \bar{x} \quad (20)$$

Now, a second order approximate identity is desired. To realize it, use is made of $\hat{1}_1$ directly available as a component, and the block diagram Fig. 9 gives the next higher order approximate identity with the following control equation

$$\bar{y} = \frac{2 + 2s}{2 + 2s + s^2} \bar{x} \quad (21)$$

Note that this second order system has a damping coefficient $1/\sqrt{2}$, the most interesting in physical systems, and furthermore, that replacing s by τs does not affect the damping factor.

Proceeding in the same fashion, the next higher order system is generated as shown by the block diagram Fig. 10, which gives

$$\bar{y} = \frac{8 + 16s + 12s^2 + 4s^3}{8 + 16s + 12s^2 + 4s^3 + s^4} \bar{x} \quad (22)$$

Note that this process generates systems of order 2^n , n being the number of iterations applied.

A general formulation of the process can now be stated. For sake of convenience, the notation is changed as follows

$$\begin{aligned} \bar{y} &= \hat{1}_1 \bar{x} & \text{to} & \quad \bar{y} = A_0 \bar{x} \\ \bar{y} &= \hat{1}_{n+1} \bar{x} & \text{to} & \quad \bar{y} = A_n \bar{x} \end{aligned}$$

The starting point is $A_0 = 1/(1 + s)$, the simplest approximate identity.

Then

$$A_1 = 2 A_0 / (1 + A_0^2) \quad (23)$$

$$A_2 = 2 A_1 / (1 + A_1^2)$$

$$\vdots$$

$$A_{n+1} = 2 A_n / (1 + A_n^2) \quad (24)$$

Assuming that A_n generates \uparrow_{2^n} , an induction proof that A_{n+1} generates $\uparrow_{2^{(n+1)}}$, establishes the generality of the process. A_n is written

$$A_n = \frac{\alpha_0 + \alpha_1 s + \alpha_2 s^2 + \dots + \alpha_{(2^n-1)} s^{(2^n-1)}}{\alpha_0 + \alpha_1 s + \alpha_2 s^2 + \dots + \alpha_{(2^n-1)} s^{(2^n-1)} + \alpha_{2^n} s^{2^n}} = \frac{N}{D} \quad (25)$$

$$\begin{aligned} A_{n+1} &= 2 A_n / (1 + A_n^2) \\ &= \frac{2 N/D}{1 + (N^2/D^2)} = \frac{2 ND}{N^2 + D^2} \end{aligned} \quad (26)$$

$$D = N + \alpha_{2^n} s^{2^n} = N + Z, \quad Z = \alpha_{2^n} s^{2^n}$$

$$A_{n+1} = \frac{2N(N+Z)}{(N+Z)^2 + N^2} = \frac{2N^2 + 2NZ}{2N^2 + 2NZ + Z^2} \quad (27)$$

The highest order term in the numerator is given by $2NZ$ and is of order $(2^n-1) + 2^n = 2^{n+1} - 1$. The highest order term in the denominator is $Z^2 = 2^n + 2^n = 2^{n+1}$ and

$$P_{(2^{n+1}-1)}(s) / P_{(2^{n+1})}(s) \quad (28)$$

Note that the general process $A_{n+1} = \frac{1}{1/2 (A_n + 1/A_n)}$ is the inverse of the Newton approximation to $\sqrt{1}$.

(a) Newton Process. What is meant by Newton approximation to $\sqrt{1}$?

Consider the function $f(x) = x^2 - 1$, if x_0 is a first estimate to the root, a better approximation x_1 is obtained by applying the Newton process,

$$x_1 = x_0 - \frac{x_0^2 - 1}{2x_0} \quad (x_0 \neq 0) \quad (29)$$

$$x_1 = (1/2) (x_0 + 1/x_0) \quad (30)$$

Note also that if x_0 is an estimate to $\sqrt{1}$, $1/x_0$ is an equally accurate estimate provided that the error is small.

If instead of number elements operators are considered and A_n is an operator estimate to $\sqrt{1}$, then $1/A_{n+1} = (1/2) (A_n + 1/A_n)$ is a more accurate one. Since, as mentioned earlier, A_{n+1} and $1/A_{n+1}$ are equally accurate estimates, the iteration formula for an improved operator to $\sqrt{1}$ and by the same way to 1 is written

$$A_{n+1} = 2A_n / (1 + A_n^2) \quad (31)$$

The latter form is preferable because physical transfer functions have the degree of the numerator smaller than the degree of the denominator.

In other words, if an approximate identity of the n^{th} order is used in the previous process, a higher order approximate identity is obtained. This is realized physically using the servo structure shown in Fig. 11 where the forward transfer function is $2A_n$, the feedback element being $(1/2)A_n$.

It is interesting to note that the Newton process applied to the approximate identity operator generates approximate identities of order 2^n , where n is the number of iterations of the process. The next questions which arise are, "Would there exist a process similar to Newton's, but which would increase more rapidly the order of the approximate identity and what would its physical counterpart be in terms of servo structure?" These questions are answered by the Halley process for $\sqrt{1}$ which is realized by the "linear adaptive" servo structure.

(b) The Halley Process. A third order process to evaluate $\sqrt{1}$ is the Halley improvement

$$x_1 = x_0 \frac{x_0^2 + 3}{3x_0^2 + 1} \quad (32)$$

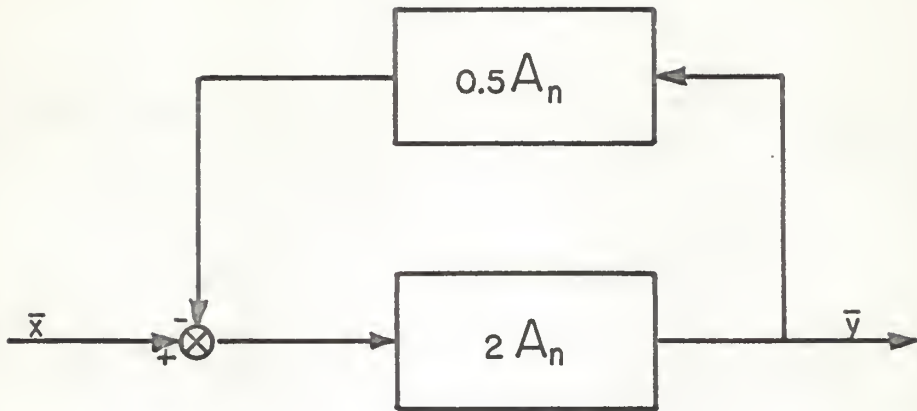

FIG. 11 Newton Process for Approximate Identity Improvement

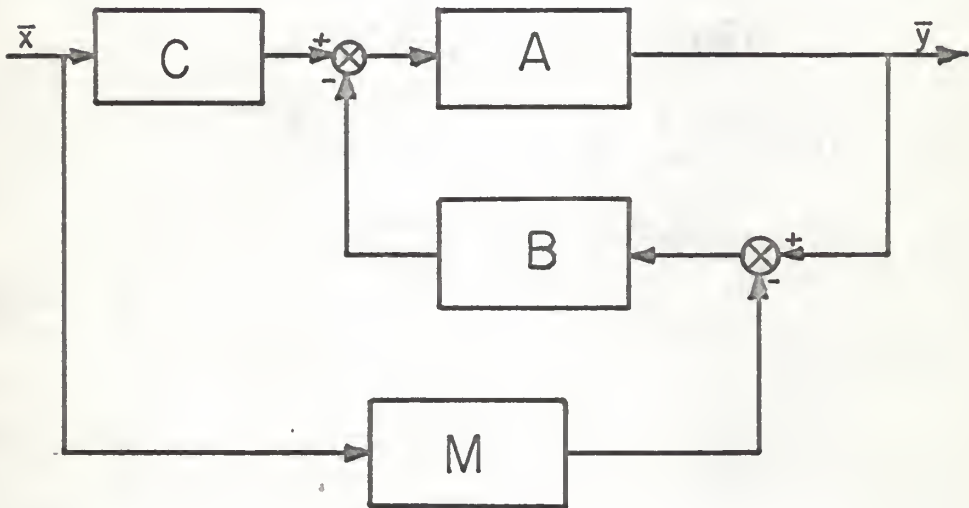

FIG. 12 Generalized Controller Canonical Form

In the operator domain, a given approximate identity A_n , subjected to the Halley process yields an approximate identity of higher order. Its physical counterpart is the "linear adaptive" servo as shown by the block diagram in Fig. 12. The general form of controller's transfer function is

$$\bar{y} = (C + EM) \frac{A}{1 + AB} \bar{x} \quad (33)$$

which by identifying with the Halley process takes the canonical form shown in Fig. 13. Writing the Halley process as $\bar{y} = (3 + A^2) \frac{A}{1 + 3A^2} \bar{x}$ enables easy identification of the different elements of the "linear adaptive" structure. The structure thus obtained reveals an entirely different meaning to the "linear adaptive" servo.

Given a system A which is a servo to a unit step, the structure defined in Fig. 13 is a servo to a unit step, to a unit ramp and unit acceleration inputs. Apply the Halley process to the first order system $A = 1/(1 + s)$,

$$\begin{aligned} T(s) &= \frac{(3 + A^2)}{1 + 3A^2} A \\ T(s) &= \frac{4 + 6s + 3s^2}{4 + 6s + 3s^2 + s^3} \end{aligned} \quad (34)$$

which is a third order approximate identity practically realized by an "adaptive" structure shown in Fig. 14. Thus, a high performance servo is obtained easily, from the simplest approximate identity.

The use of Halley process is rather interesting in that it opens wide the field of "linear adaptive" servo since the usual procedure in this field was a cut and try method, where given a system, for a desired model to be followed, the feedback loop was adjusted more or less empirically. If improved performances to polynomial type inputs are wanted, then well-determined structures exist. However, if the idea that approximating processes to $\sqrt{1}$

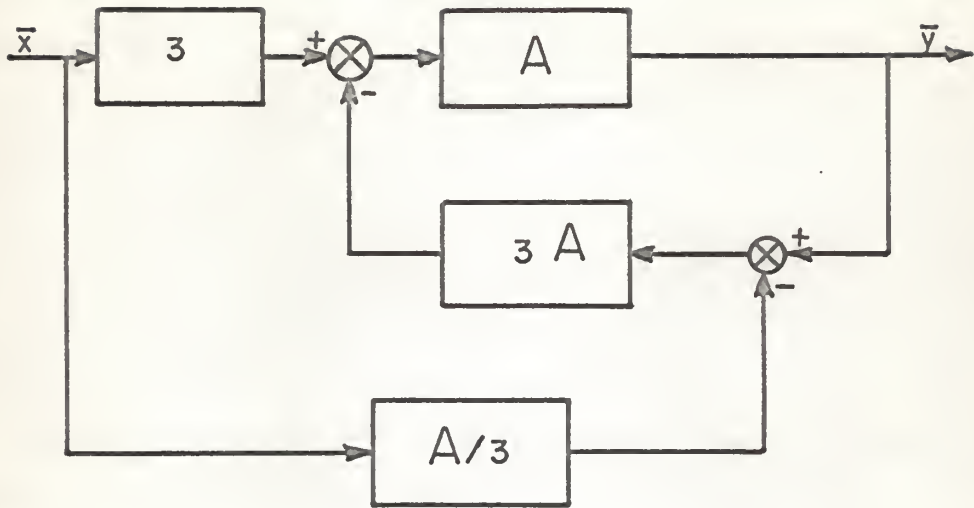

FIG.13 Halley Process for Approximate Identity Improvement

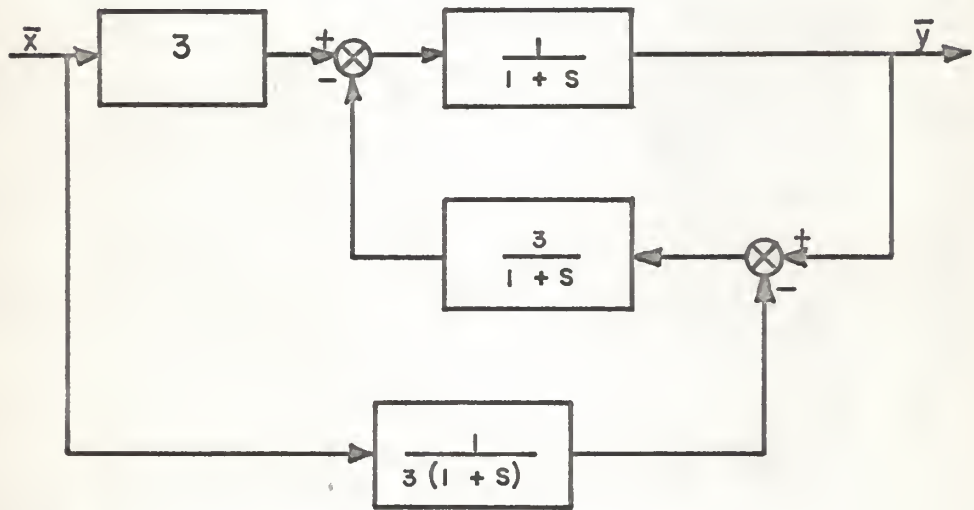

FIG.14 Example of an Approximate Identity Improvement
Using Halley Process

generate approximate identities in the operator domain, then higher order processes need to be investigated.

(c) General Approximate Identity Improvement Process. The Newton and the Halley processes possess the property that the numerator and denominator polynomials have coefficients which are respectively the odd and even coefficients of the binomial expansion of $(1 + A)^2$ for Newton process and of $(1 + A)^3$ for Halley's. This leads to the theorem: Given an approximate identity of the form $A_k = \frac{P_k(s)}{P_k(s) + x_k}$ with $x_k = a_k s^m$ and $\deg P_k = m - 1$ then

$$A_{k+1} = \frac{\sum_{r=1,3,5}^{n-1} \binom{n}{r} A_k^r}{\sum_{r=0,2,4}^{n-1} \binom{n}{r} A_k^r} = \frac{P_{k+1}(s)}{P_{k+1}(s) + x_{k+1}} \quad (35)$$

with $\deg x_{k+1} = m n$, $\deg P_{k+1} = m n - 1$

Indeed this theorem gives completion to the previous processes.

Proof:

$$A_{k+1} = \frac{\sum_{r=1,3,5}^{n-1} \binom{n}{r} \left(\frac{P}{P+x}\right)^{n-r}}{\sum_{r=0,2,4}^n \binom{n}{r} \left(\frac{P}{P+x}\right)^{n-r}} = \frac{\sum_{r=1,3,5}^{n-1} \binom{n}{r} P^{n-r} (P+x)^r}{\sum_{r=0,2,4}^n \binom{n}{r} P^{n-r} (P+x)^r} \quad (36)$$

Expanding $(P+x)^r$ yields

$$A_{k+1} = \frac{\sum_{r=1,3,5}^{n-1} \binom{n}{r} P^{n-r} \sum_{m=0}^r \binom{r}{m} P^{r-m} x^m}{\sum_{r=0,2,4}^n \binom{n}{r} P^{n-r} \sum_{m=0}^r \binom{r}{m} P^{r-m} x^m} \quad (37)$$

$$A_{k+1} = \frac{\sum_{r=1,3,5}^{n-1} \binom{n}{r} \sum_{m=0}^r \binom{r}{m} P^{n-m} x^m}{\sum_{r=0,2,4}^n \binom{n}{r} \sum_{m=0}^r \binom{r}{m} P^{n-m} x^m} \quad (38)$$

Commuting summation according to the schematic of Fig. 15 yields

$$A_{k+1} = \frac{\sum_{m=0}^{n-1} P^{n-m} x^m \sum_{\text{odd } r=m}^{n-1} \binom{n}{r} \binom{r}{m}}{\sum_{m=0}^n P^{n-m} x^m \sum_{\text{even } r=m}^n \binom{n}{r} \binom{r}{m}} \quad (39)$$

Using the relation

$$\binom{n}{r} \binom{r}{m} = \binom{n}{m} \binom{n-m}{r-m} \quad (40)$$

odd $r = m$ means $r = 1, 1, 3, 3, 5, 5, \dots$
 when $m = 0, 1, 2, 3, 4, 5, \dots$
 even $r = m$ means $r = 0, 2, 2, 4, 4, 6, 6, \dots$
 when $m = 0, 1, 2, 3, 4, 5, 6, \dots$

The next form is obtained

$$A_{k+1} = \frac{\sum_{m=0}^{n-1} P^{n-m} x^m \binom{n}{m} \sum_{\text{odd } r=m}^{n-1} \binom{n-m}{r-m}}{\sum_{m=0}^n P^{n-m} x^m \binom{n}{m} \sum_{\text{even } r=m}^{n-1} \binom{n-m}{r-m}} \quad (41)$$

Considering the relations

$$(1+1)^{n-1} = \sum_{k=0}^{n-1} \binom{n-1}{k} = 2^{n-1} \quad (42)$$

and

$$\binom{n-1}{r} + \binom{n-1}{r-1} = \binom{n}{r} \quad (43)$$

yields

$$\sum_{k=0,1,2,3}^{n-1} \binom{n-1}{k} = \sum_{k=0,2,4}^{n-2} \binom{n-1}{k} + \binom{n-1}{k+1} = \sum_{k=0}^{n-2} \binom{n}{k+1} \quad (44)$$

$$= \sum_{k=1,3,5}^{n-1} \binom{n}{k} = 2^{n-1} \quad (45)$$

and also

$$\sum_{k=0,2,4}^n \binom{n}{k} = 2^{n-1} \quad (46)$$

The two different cases m odd and m even are denoted by m_o and m_e , for the case of even n .

$$\binom{n}{m} \sum_{\text{odd } r=m}^{n-1} \binom{n-m}{r-m} = \begin{cases} \binom{n}{m_o} \sum_{\text{odd } r=m_o}^{n-1} \binom{n-m_o}{r-m_o} = \binom{n}{m_o} 2^{(n-m_o-1)+1} \\ \binom{n}{m_e} \sum_{\text{odd } r=(m_e+1)}^{n-1} \binom{n-m_e}{r-m_e} = \binom{n}{m_e} 2^{(n-m_e-1)} \end{cases} \quad (47)$$

$$\binom{n}{m} \sum_{\text{even } r=m}^{n-1} \binom{n-m}{r-m} = \begin{cases} \binom{n}{m_o} \sum_{\text{even } r=(m_o+1)}^n \binom{n-m_o}{r-m_o} = \binom{n}{m_o} 2^{(n-m_o-1)+1} \\ \binom{n}{m_e} \sum_{\text{even } r=m_e}^n \binom{n-m_e}{r-m_e} = \binom{n}{m_e} 2^{(n-m_e-1)} \end{cases} \quad (48)$$

The upper form of equation (47) is equal to the upper form of equation (48) and the lower form of equation (47) is equal to the lower form of equation (48). This proves that the relation (41) can be written as follows

$$A_{k+1} = \frac{\sum_{m=0}^{n-1} B_m P^{n-m} x^m}{\sum_{m=0}^{n-1} B_m P^{n-m} x^m + x^n} \quad (49)$$

where B_m represents one of the coefficients evaluated here above depending on the nature of m and n . The same proof can be extended to odd n . Therefore, the binomial expansion generates iterative process for realizing approximate identity operators.

(d) Interrelationship of Newton and Halley Processes. If $B_n(s)$ is the transfer function of a n^{th} order approximate identity derived by iteratives of Newton and Halley processes from an initial $A(s)$, then $B_n(s)$ is a ratio of even part to odd part of $(1 + A(s))^n$. This can be formulated succinctly as

$$\frac{1 - B_n(s)}{1 + B_n(s)} = \left[\frac{1 - A(s)}{1 + A(s)} \right]^n \quad (50)$$

which is a Newton process for even n and a Halley process for odd n . A formula for adjacent $B_n(s)$ shows the relationship of Newton and Halley processes; such is derived from

$$\frac{1 - B_{n+1}(s)}{1 + B_{n+1}(s)} = \frac{1 - A(s)}{1 + A(s)} \frac{1 - B_n(s)}{1 + B_n(s)} \quad (51)$$

yielding

$$B_{n+1}(s) = \frac{A(s) + B_n(s)}{1 + A(s) B_n(s)} \quad (52)$$

This form is a special case of Richards' equation for a positive real function. The improvement structure shown in Fig. 16 gives the physical counterpart of this result.

Because of its simplicity and generality, the structure in Fig. 16 is a

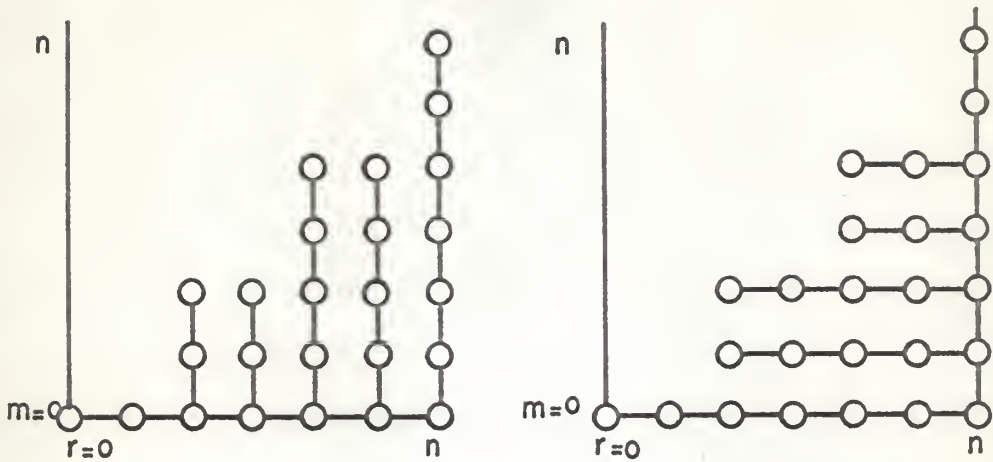

FIG. 15 Summation Commuting Diagram

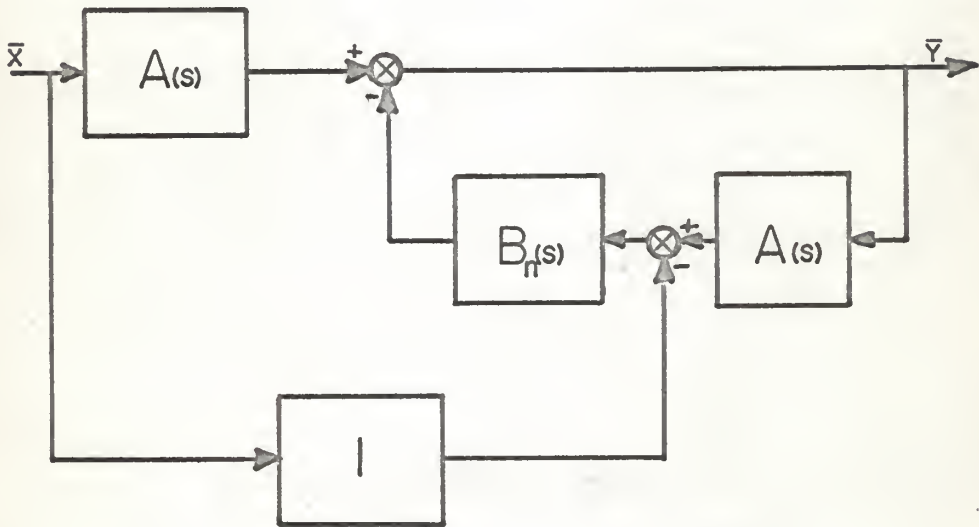

FIG. 16 Approximate Identity Improvement Canonical Form for any Newton Process Iterate $n \geq 1$, $B_n(s) = A_0(s)$

canonical form for approximate identity improvement. It is the reality behind the term, "linear adaptive servo". Moreover, the accepted "linear adaptive servo" is a model for a controller. One can only conclude that "linear adaptive servo" is an imprecise misnomer and recommend that the term be dropped.

TRANSIENT BEHAVIOR

It has been shown in the previous sections how synthesis of servos is accomplished with the concept of approximate identity. Newton processes and their physical realization as servo structures have been used to this end.

However, this synthesis technique is based on steady-state behavior; nothing is known about the transient performances of such developed systems. The next step will be to analyze the transient behavior of certain approximate identities. It is rather difficult to derive general rules about the effect of Newton or Halley processes on performance - this limitation arises from the non-linear nature of the transformation and transient performance has to be investigated for specific cases. Position of the poles and zeros of a system determines transient behavior. A graphical method analogous to Evans' root-locus technique (6) is developed to find the poles and zeros of a system given the poles and zeros of the original system. Attention is called to the fact that the term, "root-locus", is used, but this locus differs from the root-locus ordinarily encountered in servo design and the rules of construction are broadly similar though different in detail.

1. Properties of Newton Process.

Limited and relative stability criteria are easily effected by Routh's array which is Euclid's algorithm for finding highest common factors.

Fundamentally, stability analysis is of secondary importance in our study since it will be shown that given an initially stable system, any other system generated from that initial system is stable. The problem is solved by proving that the transformation $0.5 [A + (1/A)]$ yields a positive real function if A is a positive real function. (The transformation $0.5 (A+A^{-1})$ is known as the Joukowski transformation in airfoil theory). Analysis of mapping properties of $f(Z) = 1/2 (Z + (1/Z))$ when

$$Z = \rho e^{j\phi} = x + jy \quad (53)$$

$$X + jY = 1/2 (\rho e^{j\phi} + (1/\rho) e^{-j\phi}) = f(Z)$$

gives the equation of a hyperbola

$$\frac{X^2}{\cos^2 \phi} - \frac{Y^2}{\sin^2 \phi} = 1 \quad (54)$$

Figure 17 shows the results of the mapping of the (x, y) plane into the (X, Y) plane through the Newton process. It is readily seen that the right half plane is mapped onto itself so the Newton process yields a positive real function. Knowing that a positive real function of a positive real function is a positive real function, Newton processes, $A_{n+1} = 0.5 [A_n + (1/A_n)]$, generate positive real functions if the initial one was such. Since a positive real function has neither pole nor zero in the right half plane, all transfer functions generated are stable. The same statement applies to the transformation of A into B_n defined by

$$\frac{1 - B_n}{1 + B_n} = \left[\frac{1 - A}{1 + A} \right]^n \quad n = 2, 3, 4, \dots$$

and the proof is by simple conformal mapping arguments. Of course, the case $n = 2$ is the Newton process and the case $n = 3$ is the Halley process.

Distribution of the poles and zeros of transfer functions generated by Newton processes is investigated next.

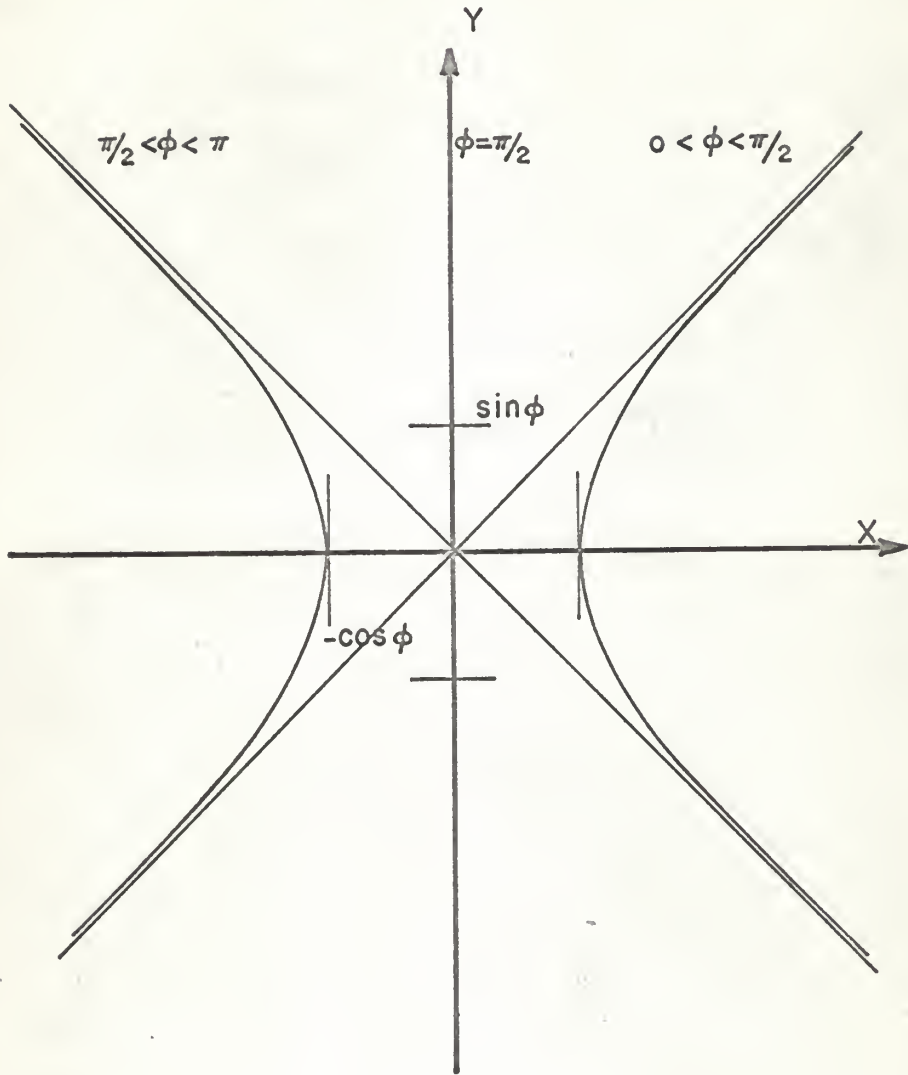

FIG. 17 Mapping of $0.5(z + 1/z)$

2. Distribution of Poles and Zeros.

The Newton process is defined as follows: given A_0 , $A_{n+1} = 2A_n / (1 + A_n^2)$ where A_n is an approximate identity operator. A_n can be written as $N_n(s) / D_n(s)$ where $N_n(s)$ and $D_n(s)$ are polynomial functions of s . The Newton process operation then gives

$$A_{n+1} = \frac{2N_n D_n}{N_n^2 + D_n^2} \quad (55)$$

From this expression of A_{n+1} it is seen that the zeros of the generated system are the same as the poles and zeros of the initial system. The poles of A_{n+1} are the solution of the equation $1 + A_n^2(s) = 0$ or

$$A_n(s) = \pm j 1 \quad (56)$$

which is satisfied if the following conditions are met

$$|A_n(s)| = 1 \quad (57)$$

$$\text{Arg } A_n(s) = (2k + 1) \pi / 2 \quad (58)$$

where $k = 0, 1, 2, 3, \dots$ all integers.

Let us consider $A_n(s)$ in a general form and not assume as before, that it is an approximate identity, it is written as

$$A_n(s) = \frac{K (s+z_1) (s+z_2) \dots (s+z_n)}{(s+p_1) (s+p_2) \dots (s+p_n)} \quad (59)$$

where K is an undetermined constant. The previous equations are then written

$$|A_n(s)| = K \frac{\prod_{i=1}^n |(s + z_i)|}{\prod_{j=1}^n |(s + p_j)|} = 1 \quad (60)$$

$$\text{Arg } [A_n(s)] = \sum_{i=1}^m \text{Arg } (s+z_i) - \sum_{j=1}^n \text{Arg } (s+p_j) = (2k+1) \pi / 2 \quad (61)$$

These two relations lead to a root-locus and the zeros of $1 + A_n^2$ are obtained by finding, by trial and error, the points satisfying $K = a$ on the locus, where a is the value of the constant corresponding to the original servo system.

Rules for the construction of the loci of the roots of the system of equations (60) and (61) where K is a parameter, are derived.

(a) The problem is to find the roots of

$$A_n(s) = \pm j 1 \quad \text{or} \quad \begin{cases} A_n(s) = + j 1 \\ A_n(s) = - j 1 \end{cases} \quad (62)$$

This statement of the problem shows that the loci are symmetrical with respect to the real axis; so it will be sufficient to determine only the upper-half of the loci; the other part is deduced by symmetry.

(b) The root loci start at the poles of $A(s)$ given by

$$|A_n(s)| = \frac{\prod_{i=1}^n |(s+z_i)|}{\prod_{j=1}^n |(s+p_j)|} = \frac{1}{K} \quad (63)$$

The starting points of the loci are at $K = 0$

(c) The end points of the root loci corresponding to $K = \infty$ are the zeros of $A_n(s)$.

(d) The number of loci is equal to the number of poles of $A_n(s)$ having previously made the restriction that deg of numerator < deg of denominator.

(e) For large values of s , the root loci are asymptotic to straight lines. Determination of these asymptotes proceeds as follows:

$A_n(s)$ has the form

$$A_n(s) = \frac{(a_0 + a_1 s + \dots + a_{m-1} s^{m-1} + a_m s^m) K}{a_0 + a_1 s + \dots + a_{m-1} s^{m-1} + a_m s^m + \dots + s^n} \quad (64)$$

which is an $(m+1)^{th}$ order approximate identity. Introducing the parameter K for the construction of the root loci, equation (64) is written

$$A_n(s) = \frac{K}{\frac{a_0 + a_1 s + \dots + a_m s^m + \dots + s^n}{a_0 + a_1 s + \dots + a_m s^m}} \quad (65)$$

Performing the synthetic division, the following form is obtained for the solution of $1 + A_n^2 = 0$

$$(1/a_m) s^{n-m} + (a_{n-1} - \frac{a_{m-1}}{a_m}) (1/a_m) s^{(n-m-1)} + \dots = K e^{j(2k+1)\pi/2} \quad (66)$$

Since determination of asymptotes is sought, only the highest powers of s are considered and the equation of the asymptotes is given as

$$s^{n-m} + (a_{n-1} - a_{m-1}/a_m) s^{(n-m-1)} = K' e^{j(2k+1)\pi/2} \quad (67)$$

Let us call $n - m = N$ the difference in degree between denominator and numerator, or the difference between the number of poles and zeros $N = P - Z$.

Equation (67) is then written

$$s^N + (a_{n-1} - a_{m-1}/a_m) s^{N-1} = K' e^{j(2k+1)\pi/2} \quad (68)$$

Define $b_m = a_{m-1}/a_m$

$$s \left[1 + (a_{n-1} - b_m)/s \right]^{1/N} = K'^{1/N} e^{j(2k+1)\pi/2N} \quad (69)$$

The factor $\left[1 + (a_{n-1} - b_m)/s \right]^{1/N}$ is expanded in infinite series and if terms higher than the second order are neglected, the following form

$$s \left[1 + (a_{n-1} - b_m)/Ns \right] = K'^{1/N} e^{j(2k+1)\pi/2N} \quad (70)$$

is obtained.

Equation (70) in the s -plane is recognized as the equation of a straight line

$$\sigma + j\omega + (a_{n-1} - b_m)/N = K'^{1/N} e^{j(2k+1)\pi/2N} \quad (71)$$

Identification of real and imaginary parts yields the following result

$$w = \left[\tan \frac{(2k+1)\pi}{2N} \right] \left[\sigma + (a_{n-1} - b_m)/N \right] \quad (72)$$

Equation (72) has the form

$$w = m(\sigma - \sigma_1) \quad (73)$$

an equation of a straight line, where m is the slope and σ_1 the point of intersection with the real axis.

Recalling from the theory of equations the following results

$$a_{n-1} = \sum \text{poles of } A_n(s)$$

$$b_m = a_{m-1}/a_m = \sum \text{zeros of } A_n(s) \quad (74)$$

it can be stated that the angles of the asymptotes with the real axis are $(2k+1)\pi/2N$ and their intersection with the real axis is

$$\sigma_1 = - \left[\sum \text{poles of } A_n(s) - \sum \text{zeros of } A_n(s) \right] / N \quad (75)$$

(f) Breakaway points: these should occur only when the initial system has multiple poles, and the root loci must approach and leave breakaway point on the real axis at an angle of $90 \text{ deg}/n$ apart, where n is the number of root loci approaching and leaving the point.

(g) Angles of departure from poles and angles of arrival at zeros of the root loci. These angles are readily obtained from the fact that

$$\sum \text{Arg}(s+z_i) - \sum \text{Arg}(s+p_j) = (2k+1)\pi/2 \quad (76)$$

To get the poles of the transformed servo, the points satisfying $K=a$ corresponding to $A_n(s)$ being an approximate identity, have to be found. This is obtained, by graphical trial and error, by finding the points s_p for which the ratio of the magnitude of the vectors respectively to the poles and zeros is equal to a .

The spirule is of great help in the graphical determination of the

root-locus; however, it should be remembered that in this case, a point to be part of the locus should have an argument of $(2k+1)\pi/2$, which will be read on the spirule either $\pi/2$ or $3\pi/2$.

An example is now given. Suppose a system transfer function is given to be $A_1(s) = \frac{1+2s}{(1+s)^2}$, an approximate identity of the second order. Use of the Newton process generates the higher order approximate identity.

$$A_2(s) = \frac{2 + 8s + 10s^2 + 4s^3}{2 + 8s + 10s^2 + 4s^3 + s^4} \quad (77)$$

Transient behavior of this system is determined by the position of its poles and zeros. It is known that its zeros are the poles and zeros of $A_1(s)$ so $Z_1 = -1/2$ is a zero of order 1 and $Z_2 = -1$ is a zero of order 2. The poles are obtained by constructing the root-locus for $A_1(s)$. The following results concerning the loci are obtained using previously established rules:

The starting points of the loci are at $s = -1$, double pole of $A_1(s)$; one of the loci ends at $s = -1/2$, the other terminates at infinity; the angles of departure at the breakaway point $s = -1$ are 45° and 135° ; the angle of the asymptotes is $(2k+1)\pi/2$ and the intersection with the real axis is

$$\sigma_1 = -(2 - 1/2) = -1.5$$

The upper part of the root-locus is then easily drawn with the spirule as the rectangular strophoid in Fig. 18. The points satisfying $K = 2$ are found by trial and error; these points and their complex conjugates are the poles of $A_2(s)$ which are

$$-0.55 \pm j 0.1$$

$$-1.45 \pm j 2.1$$

Complete knowledge of the system with transfer function $A_2(s)$ is obtained and its response to a unit step is shown in Fig. 19. This example shows the excellent transient behavior of a fourth order system generated by a Newton

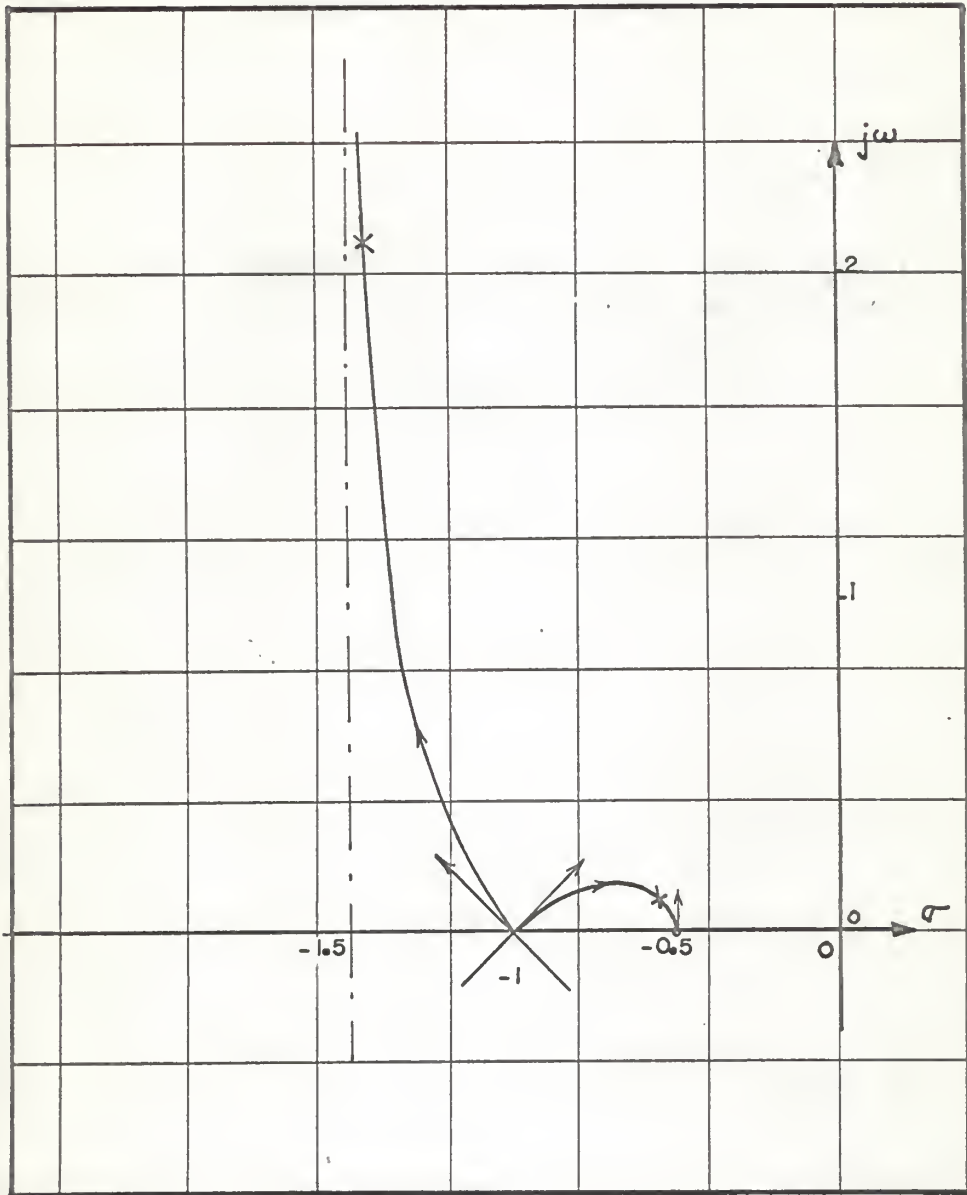

FIG. 18 Root Locus Of $A(s) = \frac{1+2s}{1+2s+s^2}$

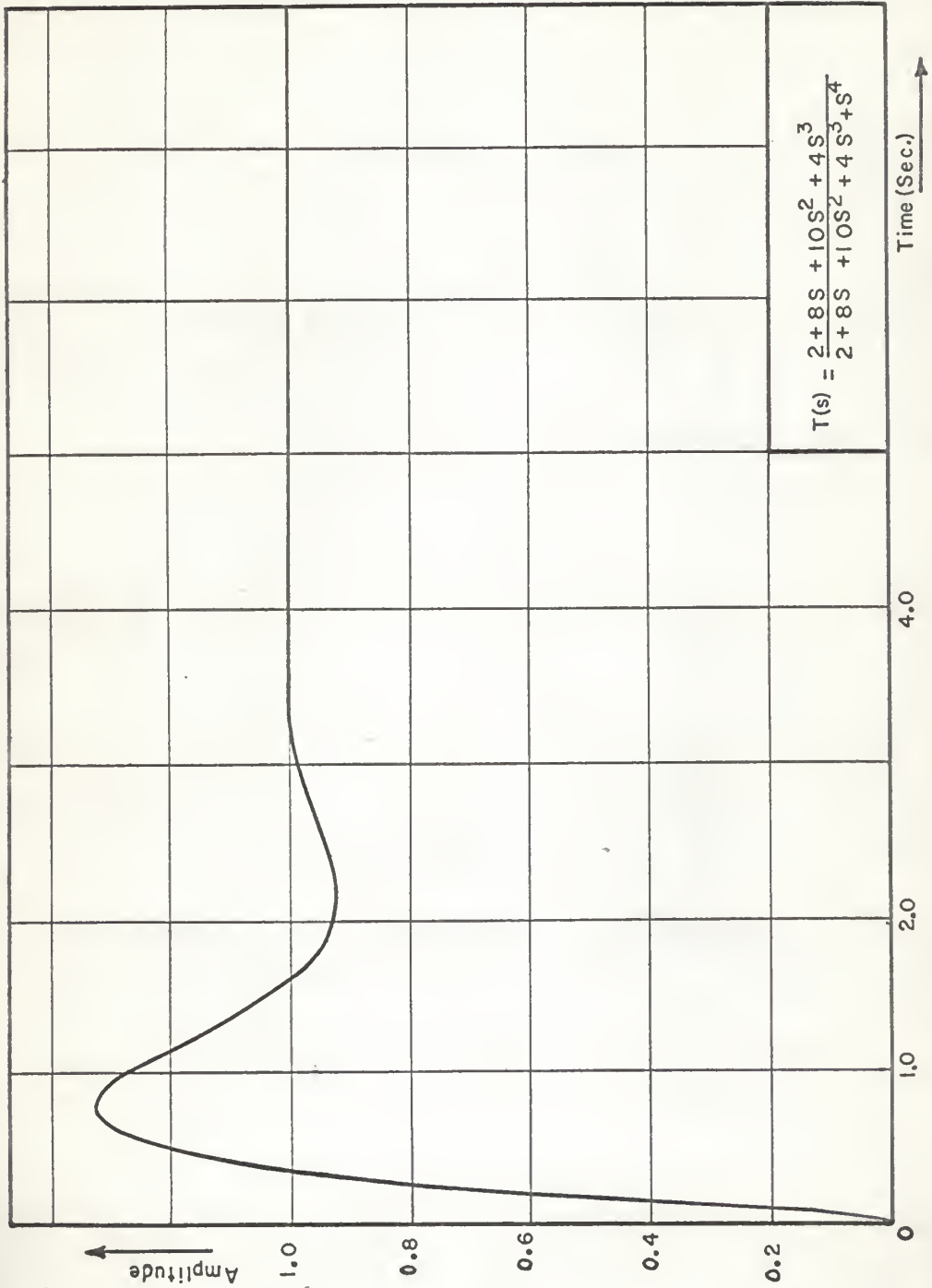

FIG.19 Fourth Order Approximate Identity Response to a Unit Step Input

process which is without steady-state error up to $\left(\frac{d}{dt}\right)^3$ and is very rapidly obtained from the pole and zero distribution. Note that the simplicity of the method comes partly from the fact that to determine the poles of a $2n$ order system, a root locus for a n^{th} order system only needs to be constructed.

Another example with particularly interesting properties is now given.

A first order system $A_0 = a/(a+s)$ with a pole at $-a$, transforms into $A_1 = \frac{2a(a+s)}{(s+a)^2 + a^2}$ which has a pair of complex poles at $s = -a \pm j a$. It is noted that the real negative part of the poles is unchanged. From the root-locus technique developed, it is predictable that systems obtained by Newton processes from initial systems of the form of A_0 and A_1 will have all their poles and zeros with real parts unchanged. This is proved by noticing that for such systems, the asymptote and the root locus are the same. Such a configuration though apparently unrealistic presents an ideal system with all time-constants equal. One might note too that applying the Newton process several times leads to oscillatory type of systems; the poles being pushed further from the real axis (see Fig. 20) toward the j -axis. This implies that the Newton process should be used once.

3. Comparison of Newton Processes and other Optimization Criteria

Approximate identity performance improvement generated by Newton process and analysis of the transient behavior by a root-locus technique are the basis for the servo synthesis procedure given in this report. Although, the distribution of the poles and zeros of the system is known and can be accepted as a performance criterion, a comparison test is made with other optimization criteria. Schultz and Rideout (7) give a comparative analysis of optimization criteria justifying their existence often-times on their ease of application and on the fact that each is a metric; under this

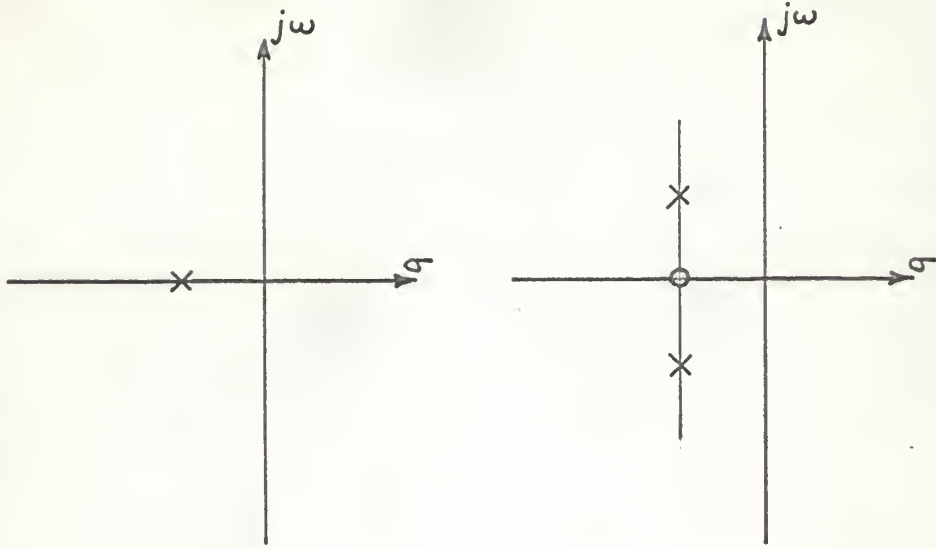

Initial System $\frac{a}{a+s}$

First Newton Process Iterate

$$\frac{2a^2+2as}{2a^2+2as+s^2}$$

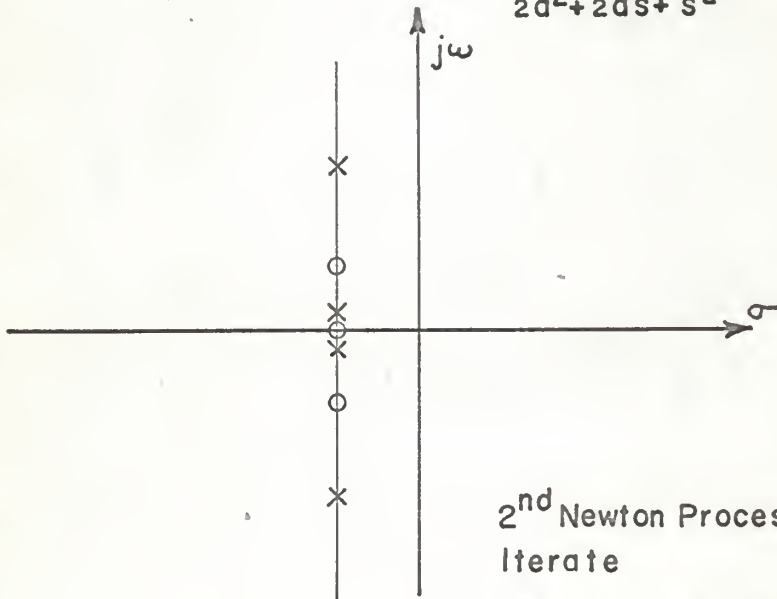

2nd Newton Process Iterate

$$\frac{8a^4+8a^3s+12a^2s^2+4as^3}{8a^4+8a^3s+12a^2s^2+4as^3+s^4}$$

FIG.20 Pole and Zero Location

last condition, performance can be measured by a single number, a rather presumptuous situation. All these accepted criteria use an integral as measure of system error and the system which causes the integral to be a minimum is the best system. The actual error of the system is defined as the difference between the input and output of the system,

$$e(t) = x(t) - y(t) \quad (78)$$

The metric proposed by Hall (8) is defined by

$$E = \int_0^{\infty} e^2(t) dt \quad (79)$$

the integral of square of error (I S E). Another measure of error is the integral of error

$$E = \int_0^{\infty} e(t) dt \quad (80)$$

Nims (9) criticizes the use of this control area criterion on the basis that in the case of an oscillatory response, the control area will have both positive and negative portions. The negative area, therefore, subtracts from the final value of the integral to yield a false value of the over-all error. Nims then proposed a "weighted control area" as shown by

$$E = \int_0^{\infty} t e(t) dt \quad (81)$$

Another criterion which created a great deal of interest is the integral of time multiplied by absolute error denoted I T A E; it was introduced by Graham and Lathrop (10) and is defined as

$$E = \int_0^{\infty} t |e(t)| dt \quad (82)$$

As an example of testing by these accepted criteria, consider an approximate identity of the fourth order or in other words a servo system without error of the order $\left(\frac{d}{dt}\right)^3$. Its transfer function is given in the

general form

$$T(s) = \frac{a_0 + a_1 s + a_2 s^2 + a_3 s^3}{a_0 + a_1 s + a_2 s^2 + a_3 s^3 + a_4 s^4} \quad (83)$$

The input signal considered is a unit step $\bar{x}(s) = 1/s$. Under these assumptions the Laplace transform of the error function is given by

$$\bar{e}(s) = \frac{a_4 s^3}{a_0 + a_1 s + a_2 s^2 + a_3 s^3 + a_4 s^4} \quad (84)$$

or in a general form

$$\bar{e}(s) = s^3/D(s) \quad (85)$$

Let us analyze this form and try to draw some conclusions about performance criteria. First, consider the limit of the error as s approaches zero.

$$\lim_{s \rightarrow 0} \frac{s^3}{D(s)} = \lim_{s \rightarrow 0} \int_0^{\infty} e^{-st} e(t) dt \quad (86)$$

$$\int_0^{\infty} e(t) dt = 0 \quad (87)$$

Consider equation (85) and take the derivative with respect to s and then pass to the limit as s approaches zero to obtain

$$\lim_{s \rightarrow 0} \frac{d}{ds} \left(\frac{s^3}{D(s)} \right) = \lim_{s \rightarrow 0} \frac{d}{ds} \left[\int_0^{\infty} e^{-st} e(t) dt \right] \quad (88)$$

$$\int_0^{\infty} -t e(t) dt = 0 \quad (89)$$

The same operation of differentiation can be reapplied and the following result is obtained

$$\int_0^{\infty} t^2 e(t) dt = 0 \quad (90)$$

It is readily seen that in general for an n^{th} order approximate identity, the $(n-1)$ first moments of the error function are null. So the "deviation area", and the "weighted control area" criteria fail because no matter what the coefficients of the transfer function are, equations (87) and (89) are satisfied.

Consider the integral square error criterion

$$E = \int_0^{\infty} e(t)^2 dt \quad (91)$$

The Laplace transform of $e(t)$ is $\bar{e}(s)$ and using Parseval's theorem equation (91) is written

$$E = \int_{-\infty}^{\infty} \bar{e}(s) \bar{e}(-s) ds \quad (92)$$

$\bar{e}(s)$ being a rational form, $\bar{e}(s) = c(s)/d(s)$

$$E = \int_{-\infty}^{\infty} \frac{c(-s)}{d(-s)} \frac{c(s)}{d(s)} ds \quad (93)$$

Integrals of the form of equation (93) have been computed (11) and results are given as function of the coefficients of c and d . Then E can be minimized by finding the values of c_i and d_i such that $\frac{\partial E}{\partial c_i} = 0$ and $\frac{\partial E}{\partial d_i} = 0$.

Now let us consider the fourth order servo introduced at the beginning of this section; the integral square error criterion yields the minimization of

$$\frac{a_4 (a_1 a_2 - a_0 a_3)}{2 (a_1 a_2 a_3 - a_1^2 a_4 - a_0 a_3^2)} \quad (94)$$

Minimum E is obtained by setting $\frac{\partial E}{\partial a_i} = 0$. This leads to the following conditions

$$\left\{ \begin{array}{l} 2a_1^2 a_3 a_4^2 = 0 \\ a_1 a_2 - a_0 a_4 = 0 \\ -2a_1^3 a_4^2 = 0 \\ (2a_0 a_1 a_2 a_3 + a_0 a_1^2 a_4 - a_0^2 a_3^2 - a_1^2 - a_2^2) = 0 \\ 2a_1 a_2 (a_1 a_2 - 2a_0 a_3) + 2a_0^2 a_3^2 = 0 \end{array} \right. \quad (95)$$

This system yields the following results

$$\begin{cases} a_0 a_3 = 1 \\ a_1 a_2 = 1 \end{cases} \quad (96)$$

If normalized values are considered, the transfer function of the system under study takes the form

$$T(s) = \frac{1 + s + s^2 + s^3}{1 + s + s^2 + s^3 + a_4 s^4} \quad (97)$$

A simple stability analysis by the Routh array shows that whatever non-zero value a_4 takes, the system with the transfer function $T(s)$ (97) is unstable. It is evident that the usual optimization criteria, deviation area, weighted control area, integral square error, do not lead to consistent parameter identification and the presumed best system's existence is doubtful. This points out the advantage of this report method which yields a "good" system, the stability of which is known and can be controlled by a root-locus technique. Linear continuous servo synthesis is realized by block diagram manipulation, improvement of a known system is made by the Newton process; stability and performance measures are controlled by a root-locus technique; this method leads to an almost pure algebraic realization of a good system.

SAMPLED-DATA SERVOS

An admissibility algorithm will be derived for sampled-data servos. The following notation will be adopted: if $f(t)$ is a function of time, its Laplace transform is $\bar{f}(s)$ and its z-transform is $Z(\bar{f}(s)) = \bar{f}(z)$ where $z = e^{-Ts}$ and T is the sampling period.

The final value theorem in the z-transform domain is

$$\lim_{n \rightarrow \infty} f_n = \lim_{(1-z) \rightarrow 0} (1-z) \bar{f}(z)$$

provided the radius of convergence is 1^+ . The transfer function of the sampled-data feedback system is $T(z) = \frac{N(z)}{D(z)}$. As for continuous servos, a sampled-data system is a servo for polynomial inputs if ultimately the output of the system follows its input. Before presenting a general theory of approximate sampled-data identities, let us approach sampled-data servos through a counterexample.

Given a linear continuous servo and assume that the input signal is sampled. It is then necessary to add to the forward link a hold filter which will keep the signal constant between samples; such a system is given in Fig. 21; note that originally (see Fig. 9) this servo could follow unit step and ramp inputs. The sampled output signal is

$$Z\bar{y} = \frac{(1 - e^{-Ts}) Z \left(\frac{2}{s(1+s)} \right)}{1 + (1 - e^{-Ts}) Z \left(\frac{1}{s(1+s)^2} \right)} Z\bar{x} \quad (98)$$

Calculation of system output yields

$$Z\bar{y} = \frac{2z(1 - e^{-T}) - 2z^2(e^{-T} - e^{-2T})}{1 - z(Te^{-T} - 1 + 3e^{-T}) + z^2(Te^{-T} + 2e^{-2T} - e^{-T})} Z\bar{x} \quad (99)$$

Applying the final-value theorem for unit step and unit velocity inputs shows that the system is a servo for a unit step but that there exists a velocity-error coefficient which is a function of the sampling interval. So, the continuous servo structure does not remain valid when the transition to sampled-data systems is made. The time delay introduced by the sampler and holding filter seem to be the cause of this discrepancy.

Thus, no reliable theory can be built for sampled-data systems starting from an already existing theory for continuous systems. A completely independent theory of sampled-data approximate identities shall be established.

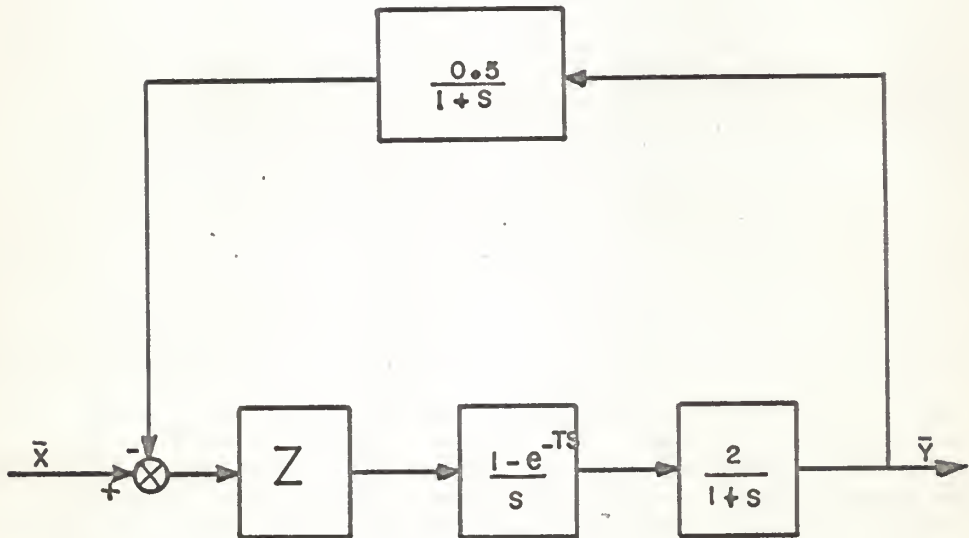

FIG. 21 A Sampled-data System

1. Sampled-Data Approximate Identities.

A sampled-data system has a transfer function of the form $T(z) = \frac{N(z)}{D(z)}$. Only polynomial inputs: unit step, velocity, acceleration, etc., will be considered. For a unit step input, the final value of the error is

$$\lim_{z \rightarrow 1} (1-z) \left[\frac{1}{1-z} - \frac{N(z)}{D(z)} \frac{1}{1-z} \right] = \frac{D(1) - N(1)}{D(1)} \quad (100)$$

For the sampled-data system to be a servo for a unit step, the relation should be

$$D(1) = N(1) \quad \text{with } D(1) \neq 0 \quad (101)$$

or in other words

$$\sum_{k=0}^n d_k = \sum_{k=0}^m n_k \quad (102)$$

d_k and n_k are respectively the coefficients of the denominator and numerator polynomials of $T(z)$.

This servo should eventually have no error for a unit velocity input.

Final value of the error to a velocity input is

$$E = \lim_{z \rightarrow 1} (1-z) \left[\frac{Tz}{(1-z)^2} - \frac{N(z)}{D(z)} \frac{Tz}{(1-z)^2} \right] \quad (103)$$

$E = \lim_{z \rightarrow 1} \frac{D(z) - N(z)}{1-z}$, an indefinite form, the limit of which is obtained by using L'Hospital's rule

$$E = \left[N'(z) - D'(z) \right]_{z=1} \quad (104)$$

A no-velocity error system is obtained if

$$N'(1) = D'(1) \quad (105)$$

or

$$\sum_{k=0}^m k n_k = \sum_{k=0}^n k d_k \quad (106)$$

In the same manner, it can be shown that a sampled-data system would have no error of order $(\frac{d}{dt})^p$ if

$$\begin{aligned} \sum_{k=0}^m n_k &= \sum_{k=0}^n d_k \\ \sum_{k=0}^m k n_k &= \sum_{k=0}^n k d_k \\ \sum_{k=0}^m k(k-1) \dots (k-p+1) n_k &= \sum_{k=0}^n k(k-1) \dots (k-p+1) d_k \end{aligned} \tag{107}$$

The following induction proof gives a justification to the previous statement and yields an algorithm similar to the linear continuous case.

Assume that a given sampled-data feedback device has zero error for polynomial inputs of the $(\frac{d}{dt})^{p-1}$ order, what is the condition that the system follows a unit $(\frac{d}{dt})^p$ type of input signal? The given assumptions can be written as

$$D^{(k)}(1) = N^{(k)}(1) \quad \text{for any } k \text{ such that } 0 \leq k \leq p-1.$$

The error is written as

$$E(z) = \left[\frac{D(z) - N(z)}{D(z)} \right] \frac{T^{p-1} z}{(p-1)!} \frac{A_p(z)}{(1-z)^p} \tag{108}$$

Here, use is made of Criswell's (12) result that

$$z \left(\frac{1}{s^p} \right) = \frac{T^{p-1} z}{(p-1)!} \frac{A_p(z)}{(1-z)^p} \tag{109}$$

where

$$A_p(z) = (1-z) \frac{d}{dz} (z A_{p-1}) + (p-1) z A_{p-1} \tag{110}$$

Final value of the error is

$$\lim_{z \rightarrow 1} (1-z) E(z) = \frac{T^{p-1}}{(p-1)!} \lim_{z \rightarrow 1} \left[\frac{D(z) - N(z)}{D(z)} \cdot \frac{z A_p(z)}{(1-z)^p} \right] \tag{111}$$

$$\lim_{z \rightarrow 1} (1-z) E(z) = \left[\lim_{z \rightarrow 1} \frac{T^{p-1}}{(p-1)!} z A_p(z) \right] \left[\lim_{z \rightarrow 1} \frac{D(z) - N(z)}{D(z) (1-z)^p} \right] \quad (112)$$

$$= T^{p-1} \left[\lim_{z \rightarrow 1} \frac{D(z) - N(z)}{D(z) (1-z)^p} \right] \quad (113)$$

The first limit follows from a result of Criswell (12) that

$$A_p(1) = (p-1)! \quad p \geq 2.$$

To obtain the second limit, L'Hospital's rule should be applied p times because of the hypothesis that $D^{(k)}(1) = N^{(k)}(1)$ for $k = p-1$, then the limit of error is

$$E = T^{p-1} \left[\frac{D^{(p)}(z) - N^{(p)}(z)}{\left[(1-z)^p D(z) \right]^{(p)}} \right]_{z=1} \quad (114)$$

Applying Leibniz' rule on differentiation of products to the denominator, the final answer

$$E = T^{p-1} \frac{D^{(p)}(1) - N^{(p)}(1)}{D(1)} \quad (115)$$

is obtained.

A zero error system is then obtained if

$$D^{(p)}(1) = N^{(p)}(1) \quad (116)$$

Therefore, an approximate identity operator of order $(p+1)$ for sampled-data servos is realized by a system which has a transfer function $T(z) = \frac{N(z)}{D(z)}$

such that

$$\begin{cases} D(1) = N(1) \\ D^{(1)}(1) = N^{(1)}(1) \\ \vdots \\ D^{(p)}(1) = N^{(p)}(1) \end{cases} \quad (117)$$

2. Approximate Identity and Sampled-Data Design.

A practical example making use of previous principles, showing their method of application and possible limitations, is now given. Consider the

system in Fig. 22 where the forward path is composed of a sampler, a hold filter with transfer function $(1-e^{-Ts})/s$ and a plant with transfer function $k/s(s+a)$; the feedback link consists of a compensator with transfer function $1/(1+\tau s)$. This system is analysed and use is made of the previous results to determine the coefficients so that a second order approximate identity is obtained.

The transfer function of the forward link of this sampled-data feedback system is $\bar{g}(s)$ and its feedback transfer function is $\bar{h}(s)$. The output signal, sampled at the same rate as the input, has the form

$$Z\bar{y} = \frac{Z\bar{g}}{1 + Z(\bar{g}\bar{h})} Z\bar{x} \quad (118)$$

In this case

$$Z\bar{g} = Z \left[\frac{K(1-e^{-Ts})}{s^2(s+a)} \right] \quad (119)$$

$$Z(\bar{g}\bar{h}) = Z \left[\frac{K(1-e^{-Ts})}{s^2(s+a)(1+\tau s)} \right] \quad (120)$$

Calculation of the z-transforms of these expressions yields

$$Z\bar{y} = \left[\frac{(Lz + Mz^2 + Nz^3)(1 - \tau\alpha)K}{E + Fz + Gz^2 + Hz^3} \right] Z\bar{x} \quad (121)$$

where

$$\begin{cases} L = \alpha T - 1 + e^{-\alpha T} \\ M = 1 - e^{-\alpha T}(1 + \alpha T) + e^{-T}(1 - \alpha T) - e^{-(\alpha+\tau)T} \\ N = e^{-(\alpha+\tau)T}(1 + \alpha T) - e^{-\tau T} \end{cases} \quad (122)$$

$$\begin{cases} E = A + 1 \\ F = B - (1 + e^{-\alpha T} + e^{-\tau T}) \\ G = C + e^{-(\alpha+\tau)T} + e^{-\alpha T} + e^{-\tau T} \\ H = D - e^{-(\alpha+\tau)T} \end{cases} \quad (123)$$

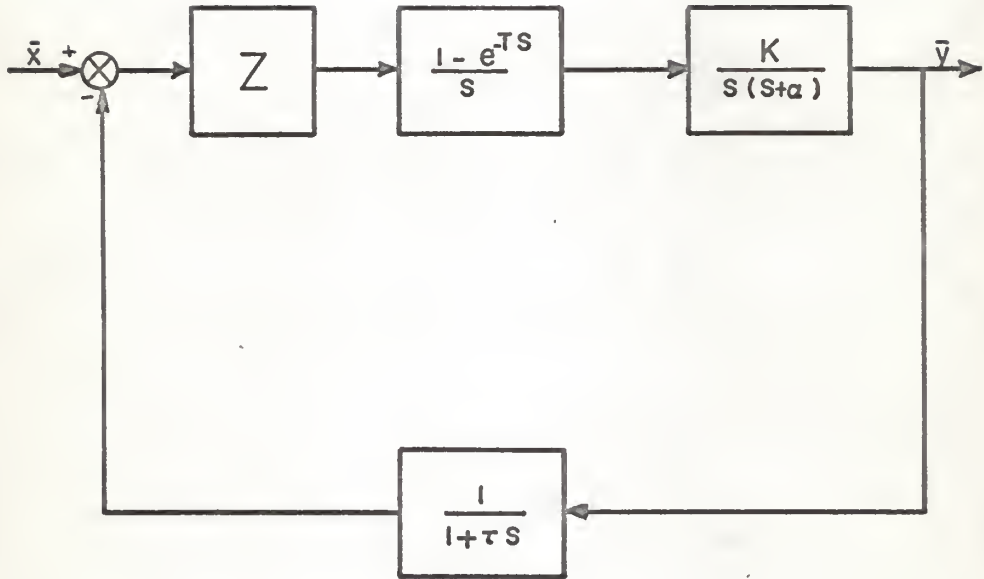

FIG. 22 Candidate for 2nd Order Approximate Identity

and

$$\begin{cases} A = K [c - b(1-\tau\alpha)] \\ B = K [(1-\tau\alpha)[a + b(e^{-\alpha T} + e^{-\tau T})] + d - 2c] \\ C = K [c - 2d + (\tau\alpha - 1) [b e^{-(\alpha+\tau)T} + a(e^{-\alpha T} + e^{-\tau T})]] \\ D = K [d + (1-\tau\alpha) a e^{-(\alpha+\tau)T}] \end{cases} \quad (124)$$

Finally, a, b, c, d have been defined for convenience of calculations

$$\begin{cases} a = (1 + T\alpha - \tau^2 \alpha^2) \\ b = (1 - \tau^2 \alpha^2) \\ c = (1 - \tau^4 \alpha^2) \\ d = (\tau^4 \alpha^2 e^{-\alpha T} - e^{-\tau T}) \end{cases} \quad (125)$$

No matter what the coefficients are, a servo for a unit step is obtained since $N(1) = D(1)$. For this feedback device to follow a unit ramp, identification of the parameters has to be made so that $N'(1) = D'(1)$. This yields the following relation between α, τ and K

$$K(\tau\alpha - 1) (\tau\alpha)^2 = 1 \quad (126)$$

The product $(\tau\alpha)$ is to be determined as function of K ; in turn determination of K can be made from a stability analysis of the system. An approximate solution of equation (126) is

$$\tau\alpha = \frac{K^4 + 12K^3 + 48K^2 + 75K + 36}{K^4 + 11K^3 + 39K^2 + 51K + 16} \quad (127)$$

This sampled-data servo admissibility problem has been solved by undetermined coefficients. It should be noted that the algebraic calculations are complex and that nothing is inferred about transient performance which will be considered in the next two sections.

3. Equivalence of Approximate Identity and Zero Error Coefficients.

In the continuous case, the approximate identity was derived from King's zero error coefficient criterion whose proof is given in appendix A. For sampled-data servos, the approximate identity has been established; and similarly to the continuous case a zero error coefficient theory will be derived which will facilitate the performance improvement calculations.

Instead of the variable z , $(1-z)$ will be used to establish the zero error coefficient criterion for sampled-data transfer functions.

Consider the transfer function

$$T(1-z) = \frac{a_0 + a_1(1-z) + a_2(1-z)^2 + \dots + a_m(1-z)^m}{b_0 + b_1(1-z) + b_2(1-z)^2 + \dots + b_n(1-z)^n} \quad (128)$$

It has been proved that given a sampled-data system with a transfer function $P(z) = \frac{N(z)}{D(z)}$, an approximate identity of order p is obtained if $N^{(k)}(1) = D^{(k)}(1)$ with $k = 0, 1, \dots, (p-1)$.

These results applied to the form $T(1-z)$ yield the following conditions for T to represent a p^{th} order approximate identity:

$$\begin{cases} T(0) & = 1 \\ T'(0) & = 0 \\ \vdots & \vdots \\ T^{(p-1)}(0) & = 0 \end{cases} \quad (129)$$

These conditions can also be written as $a_0 = b_0, a_1 = b_1, \dots, a_{p-1} = b_{p-1}$.

So an algorithm similar to the one established for continuous systems has been derived by considering the error coefficients of the transfer function expanded in $(1-z)$.

The next step is to show that given the transfer function $P(z)$, the expression $T(1-z)$ can be obtained easily. Consider, for ease of calculations,

a polynomial of the fourth order

$$A(z) = a_0 + a_1 z + a_2 z^2 + a_3 z^3 + a_4 z^4 \quad (130)$$

the corresponding form $B(1-z)$ is sought

$$B(1-z) = b_0 + b_1(1-z) + b_2(1-z)^2 + b_3(1-z)^3 + b_4(1-z)^4 \quad (131)$$

Use of the Taylor series expansion of $A(z)$ at $z=1$, leads to the expression

$$A(1-z) = A(1) + A'(1)(1-z) + \frac{A''(1)}{2!} (1-z)^2 + \frac{A^{(3)}(1)}{3!} (1-z)^3 + \frac{A^{(4)}(1)}{4!} (1-z)^4 \quad (132)$$

The values of $A(1)$, $A'(1)$, \dots , $A^{(4)}(1)$ are then computed to be

$$\begin{aligned} A(1) &= a_0 + a_1 + a_2 + a_3 + a_4 \\ A'(1) &= a_1 + 2a_2 + 3a_3 + 4a_4 \\ \frac{A^{(2)}(1)}{2!} &= (2a_2 + 6a_3 + 12a_4)/2 \\ \frac{A^{(3)}(1)}{3!} &= (6a_3 + 24a_4)/6 \\ \frac{A^{(4)}(1)}{4!} &= 24a_4/24 \end{aligned} \quad (133)$$

Identification of the b'_m s can be made and yields the following result

$$\begin{aligned} b_4 &= a_4 \\ b_3 &= a_3 + 4a_4 \\ b_2 &= a_2 + 3a_3 + 6a_4 \\ b_1 &= a_1 + 2a_2 + 3a_3 + 4a_4 \\ b_0 &= a_0 + a_1 + a_2 + a_3 + a_4 \end{aligned} \quad (134)$$

If these equations are rewritten as a double entry table,

	a_0	a_1	a_2	a_3	a_4
b_4					1
b_3				1	4
b_2			1	3	6
b_1		1	2	3	4
b_0	1	1	1	1	1

(135)

the pattern of a vertical Pascal triangle appears. In order to generalize this result, the previous table is presented in the following form

	a_0	a_1	a_2	a_3	a_4
b_4					$\binom{4}{0}$
b_3				$\binom{3}{0}$	$\binom{4}{1}$
b_2			$\binom{2}{0}$	$\binom{3}{1}$	$\binom{4}{2}$
b_1		$\binom{1}{0}$	$\binom{2}{1}$	$\binom{3}{2}$	$\binom{4}{3}$
b_0	$\binom{0}{0}$	$\binom{1}{1}$	$\binom{2}{2}$	$\binom{3}{3}$	$\binom{4}{4}$

(136)

The coefficient b_m can then be written as

$$b_m = \sum_{k=0}^n \binom{k}{k-m} a_k \tag{137}$$

where n is the degree of the polynomial involved. It is necessary to assume that $\binom{0}{0} = 1$ and $\binom{p}{-q} = 0$. An induction proof in complete form could be given but would involve heavy algebraic manipulations unnecessary to the purposes of this report. One can verify easily the exactness of the general form of b_m .

So, given a sampled-data system of transfer function

$$P(z) = \frac{\sum_{i=0}^m a_i z^i}{\sum_{j=0}^n \alpha_j z^j}$$

the corresponding transfer function

$$T(1-z) = \frac{\sum_{i=0}^m b_i (1-z)^i}{\sum_{j=0}^n \beta_j (1-z)^j}$$

is readily obtained using the relations

$$b_i = \sum_{k=0}^m \binom{k}{k-i} a_k \quad (138)$$

$$\beta_j = \sum_{k=0}^n \binom{k}{k-j} \alpha_k \quad (139)$$

Conditions for approximate identities are the same as in the continuous case, the coefficients of numerator and denominator of $T(1-z)$ must be equal pair by pair.

4. Performance Improvement.

Use is made of the similarity between the form of the approximate identity in the continuous problem and the sampled-data. If the system transfer function is written as a function of $(1-z)$, the performance improvement problem is nothing but obtaining one or two more pairs of numerator and denominator coefficients equal. So in the same manner as for continuous systems Newton processes will solve the performance improvement problem.

The procedures of the sampled-data servo problem are then summarized and a simple example is given.

- (a) Find the transfer function of the initial system $T(z)$.
- (b) Calculate the transfer function $T(d)$ of this system in the d -plane, here d is defined by $d = 1-z$, using the relations (138) and (139) established between the coefficients of $T(z)$ and $T(d)$.
- (c) Proceed to improve the system in the d -plane using Newton processes,

$$B(d) = \frac{2T(d)}{1 + T^2(d)} \quad (140)$$

- (d) Improved system transfer function in z -transform is obtained, going back into the z -domain under the transformation $d = 1-z$. So from an initial m^{th} approximate identity $T(z)$, the improved $2^n m$ order approximate identity $B(z)$ is obtained, n being the number of times this iterative process is applied.

As an example, an initial system is supposed given with the transfer function $T(z) = \frac{3}{2+z}$. In the d -domain it takes the form $T(d) = \frac{3}{3-d}$. It is an approximate identity of the first order; a second order approximate identity is obtained using Newton process

$$B(z) = \frac{18 - 6(1-z)}{18 - 6(1-z) + (1-z)^2} = \frac{12 + 6z}{13 + 4z + z^2} \quad (141)$$

Given an initial system, performances are improved and the transfer function of a better system is obtained using the procedure given above. Physically, improvement is realized by a digital controller added either in the forward or feedback links. Its transfer function is determined so that the overall system has the transfer function given by the Newton process.

An example of the arrangements possible with digital controllers is now given. Consider the system in Fig. 23; its transfer function has the form

$$T(z) = G(z) / [1 + G(z)] \quad (142)$$

where

$$G(z) = Z [H(s) M(s)] \quad (143)$$

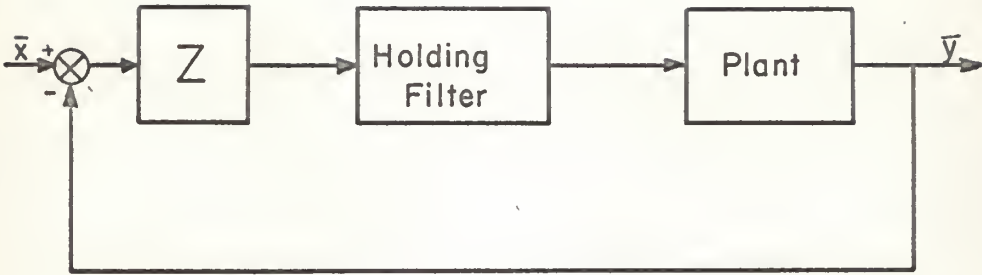

FIG.23 A Sampled-data Feedback System

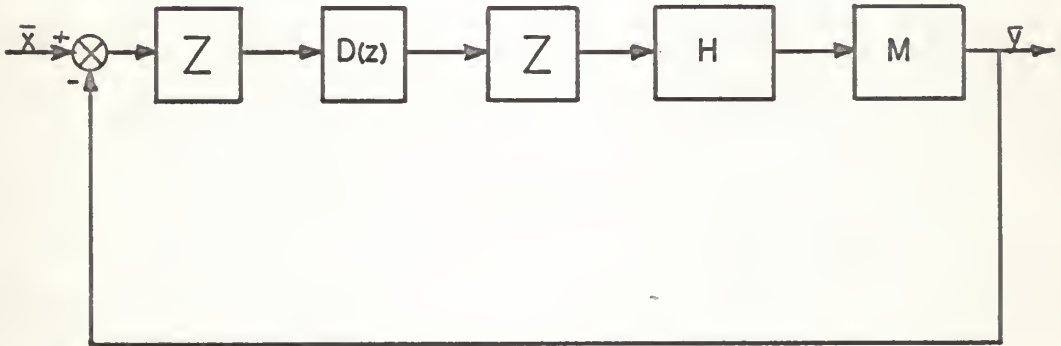

FIG.24 A Sampled-data Servo Resulting from Approximate Identity Improvement Process

D(z) is the Series Digital Compensator

$H(s)$ being the transfer function of the holding filter and $M(s)$ the transfer function of the controlled element. Performance improvement yields the transfer function $B(z)$ for the improved system. Compensation is then added in the initial system as a forward digital controller as shown in Fig. 24 and its transfer function $D(z)$ is determined so that $Z\bar{y} = B(z) Z\bar{x}$ where

$$B(z) = \frac{D(z) G(z)}{1 + D(z) G(z)} \quad (144)$$

$D(z)$ is found to be

$$D(z) = \frac{B(z)}{G(z) [1 - B(z)]} \quad (145)$$

Performance improvement has been exhibited for sampled-data servos as a steady-state problem and no information has been given about the possible control of the transient behavior of the system. It is not possible to solve the problem in every detail here but a procedure similar to the one adopted in the continuous case is easily developed.

In the z -domain the boundary of stability is the unit circle; the inside constitutes the unstable region; in other words, a sampled-data system is stable if its poles lie outside the unit circle. In the d -domain, the boundary is easily found to be the unit circle centered at $+1$. The equation of the circle in the z -plane is $z = e^{j\theta}$, mapping into the d -plane yields

$$d = a + jb = 1 - z = 1 - \cos\theta - j \sin\theta$$

Identifying real and imaginary parts gives

$$a - 1 = -\cos\theta$$

$$b = -\sin\theta$$

$$(a-1)^2 + b^2 = 1$$

equation of a circle of radius 1 centered at the point of abscissa $+1$. So, in the d -domain, the transient behavior problem is solved by knowing the distribution of the poles and zeros with respect to the unit circle centered at $+1$.

Recalling the performance improvement procedure, $T(d)$ is evaluated and then Newton process is applied to obtain $B(d) = \frac{2T(d)}{1 + T^2(d)}$. Using the analogy between the problem in the d -domain and the continuous case, it is readily seen that, knowing the distribution of the poles and zeros of the initial system $T(d)$, a root-locus technique will give the distribution of the poles and zeros of the improved system and will give control of transient behavior. This completes the performance improvement problem.

As pointed out in the introduction, although sampled-data system theory is completely unrelated to continuous systems, similar concepts and methods have been established which enable a systematic algebraic solution to the sampled-data servo problem. The concept of a sampled-data approximate identity will be a tool necessary for the analysis of multivariable sampled-data servos. The study of linear continuous multivariable servos made by C. A. Halijak and A. J. Rault (13) pointed out the two basic tools necessary: the approximate identity operator and the approximate annihilator, the latter being an extension of the no-pass filter developed previously by H. S. Lin (14). To complete the fundamental tools for multivariable sampled-data servos, the sampled-data approximate annihilator should be investigated. Annihilators have been considered by J. P. L. Ho and C. A. Halijak (15) in their paper entitled "Functions Annihilable by Sampling". A solution of the problem is given in appendix B.

CONCLUSION

A departure from the usual servo design procedure has been made by considering admissibility to be of primary importance and stability to be of secondary importance. This concept views linear, continuous and sampled servos as approximate identities. The basis for approximate identity is a zero error coefficient criterion. Performance improvement is gained by a Newton process and the transient behavior of the system is controlled by a root-locus technique. These concepts have solved the linear, continuous and sampled-data servo problems in an almost algebraic fashion.

The frequent use of approximate identity operator in this paper and further application to multivariable servos have led the author to propose that "approximate identity" be shortened to "aidentity".

Furthermore, the root-locus technique employed in this report can be distinguished from Evans' root locus technique by the term "square root locus".

ACKNOWLEDGMENT

The author wishes to express his sincere gratitude to his major professor, Dr. Charles A. Halijak, for directing this investigation and for guidance in writing this report. He wishes also to express his indebtedness to Dr. Benton D. Weathers who initiated the analysis of the sampled-data approximate identity.

Financial support given by the Engineering Experiment Station at Kansas State University enabled the author to work half-time on research on approximate identity, approximate annihilators and multivariable servo problems; this support is gratefully acknowledged.

REFERENCES

- (1) Stanton, Ralph.
Numerical Methods for Science and Engineering. Prentice Hall, 1961,
pp. 85-97.
- (2) Halley, E.
A New and General Method of Finding the Roots of Equations (in Latin)
Phil. Trans. Roy. Soc. London, vol 18, 1764, p. 136.
- (3) King, L. H.
Reduction of Forced Error in Closed-Loop Systems. Proc. IRE, August,
1953, pp. 1037-1042.
- (4) Campbell, Graham.
Use of an Adaptive Servo to Obtain Optimum Airplane Response. Cornell
Aeronautical Laboratory Report C.A.L. 84, 1957.
- (5) Carlson, Gordon E.
Simulation of the Fractional Derivative Operator \sqrt{s} and the Fractional
Integral Operator $1/\sqrt{s}$. M.S. Report, Kansas State University, 1960.
- (6) Evans, Walter R.
Control System Dynamics. New York: McGraw-Hill Book Co., 1954,
pp. 96-121.
- (7) Schultz, W. C. and V. C. Rideout.
Control System Performance Measures: Past, Present and Future.
Transactions IRE, PGAC, Vol AC6.1, 1961, pp. 22-35.
- (8) Hall, A. C.
The Analysis and Synthesis of Linear Servomechanisms. The Technology
Press, Mass. Inst. Tech. Cambridge, 1943, p. 19.
- (9) Nims, P. T.
Some Design Criteria for Automatic Controls. Trans. AIEE, Vol 70,
pt. 1, 1951, pp. 606-611.
- (10) Graham, D. and R. C. Lathrop.
The Synthesis of Optimum Transient Response: Criteria and Standard
Forms. Trans. AIEE, Vol 72 pt. 2, November 1953, pp. 278-288.
- (11) Booton, R. C., M. V. Mathews, and W. W. Seifert.
Nonlinear Servomechanisms with Random Inputs. Report 70 Mass. Inst.
Tech., Dynamic Analysis and Control Laboratory, August 1953.
- (12) Criswell, M. L.
An Algorithm for Computing the Z-Transform of $t^n/n!$. Proceedings of
the Central States Simulation Council, Kansas State University
Bulletin, Special Report 37, 1963.

- (13) Halijak, C. A. and A. J. Rault.
A Linear Multivariable Servo Structure. IEEE Transactions PTGAC,
Vol AC9,2, 1964.
- (14) Lin, H. S.
Annihilator Aspects of Transfer Functions. Unpublished Master's
Thesis, Kansas State University, 1962.
- (15) Ho, J. P. L. and C. A. Halijak.
Functions Annihilable by Sampling. AIEE Conference Paper, CP 62-1473,
1962.

APPENDIX A

Zero Error Coefficient Algorithm for Continuous Systems.

Given a stable transfer function of the form

$$T(s) = \frac{a_0 + a_1 s + a_2 s^2 + \dots + a_m s^m}{b_0 + b_1 s + b_2 s^2 + \dots + b_n s^n} \quad (146)$$

where $m < n$. If only polynomial inputs are considered, then the system will have no position, velocity, acceleration and in general up to $(\frac{d}{dt})^p$ errors if $T(0) = 1$ and $a_k = b_k$ for $k = 1, 2, \dots, p$ with $p \leq m$.

The steady-state response to an input of the form $t^{r-1}/(r-1)!$ can be found by evaluating the Laplace-transform inversion integral of $\frac{1}{s^r} T(s)$ about $s = 0$. The first forms corresponding to $r = 1, 2, 3$, are evaluated, before exhibiting the result for the general case.

For a unit step input, the steady-state output is

$$\frac{1}{2\pi j} \oint_{s=0} \frac{1}{s} T(s) e^{st} ds = \left[T(s) e^{st} \right]_{s=0} = T(0) \quad (147)$$

If $T(0) = 1$ or $a_0 = b_0$, the system is a position servo.

For a unit velocity input, similarly the output is obtained.

$$\frac{1}{2\pi j} \oint_{s=0} \frac{1}{s^2} T(s) e^{st} ds = \left[\frac{d}{ds} T(s) e^{st} \right]_{s=0} \quad (148)$$

$$= T'(0) + tT(0) \quad (149)$$

Since $T(0) = 1$, the error coefficient is readily seen to be $T'(0)$.

For a unit acceleration input, response of the system is obtained as

$$\frac{1}{2\pi j} \oint_{s=0} \frac{1}{s^3} T(s) e^{st} ds = \frac{1}{2!} \left[\frac{d^2}{ds^2} T(s) e^{st} \right]_{s=0} \quad (150)$$

$$= \left(\frac{1}{2!} \right) \left[T^{(2)}(0) + 2t T^{(1)}(0) + t^2 T(0) \right] \quad (151)$$

The output signal can be written as $(t^2/2) + E$ where E is the error expressed as $E = [1/2!] \left[T^{(2)}(0) + 2t T^{(1)}(0) \right]$.

For a general polynomial input $t^{r-1}/(r-1)!$, the output is calculated

$$\frac{1}{2\pi j} \oint_{s=0} \frac{1}{s^r} T(s) e^{st} ds = \frac{1}{(r-1)!} \left[\left(\frac{d}{ds} \right)^{r-1} T(s) e^{st} \right]_{s=0} \quad (152)$$

Leibniz' rule on differentiation of products yields

$$\left(\frac{d}{ds} \right)^{r-1} \left[T(s) e^{st} \right] = \sum_{k=0}^{(r-1)} \binom{r-1}{k} T^{(k)}(s) (e^{st})^{(r-1-k)} \quad (153)$$

and if, for ease of calculations, the case $r=5$ is developed, the output is obtained

$$\frac{1}{2\pi j} \oint_{s=0} \frac{1}{s^5} T(s) e^{st} dt = \frac{1}{4!} \left[T^{(4)}(0) + 4t T^{(3)}(0) + 6t^2 T^{(2)}(0) + 4t^3 T^{(1)}(0) + t^4 T(0) \right] \quad (154)$$

or

$$y(t) = (t^4/4!) + E \quad (155)$$

where the error is

$$E = [1/4!] \left[T^{(4)}(0) + 4t T^{(3)}(0) + 6t^2 T^{(2)}(0) + 4t^3 T^{(1)}(0) \right] \quad (156)$$

The goal of zero error coefficients is attained in the general case if

$$T(0) = 1 \text{ and } T^{(1)}(0) = T^{(2)}(0) = \dots = T^{(r)}(0) = 0.$$

A Maclaurin series expansion of $T(s)$ yields

$$T(s) = T(0) + s T^{(1)}(0) + \frac{s^2}{2!} T^{(2)}(0) + \dots + \frac{s^n}{n!} T^{(n)}(0) + \dots \quad (157)$$

Also synthetic division yields

$$T(s) = 1 + c_1 s + c_2 s^2 + \dots + c_n s^n + \dots \quad (158)$$

where the error coefficients c_i are computed as

$$\begin{cases} c_1 &= (a_1 - b_1) \\ c_2 &= (a_2 - b_2) - (c_1 b_1) \\ \vdots & \\ c_p &= (a_p - b_p) - \sum_{k=1}^{p-1} c_k b_{p-k} \end{cases} \quad (159)$$

Equating corresponding coefficients of equations (158) and (159) yields

$$\begin{aligned} T(0) &= 1 \\ T^{(1)}(0) &= c_1 = a_1 - b_1 \\ T^{(2)}(0) &= c_2 - b_2 - (c_1 b_1) \\ T^{(p)}(0) &= c_p = (a_p - b_p) - \sum_{k=1}^{p-1} c_k b_{p-k} \end{aligned} \quad (160)$$

To set $T^{(1)}(0) = T^{(2)}(0) = \dots = T^{(p)}(0) = 0$ is equivalent to $c_1 = c_2 = \dots = c_p = 0$ or the set of conditions

$$\begin{cases} a_1 &= b_1 \\ a_2 &= b_2 \\ \vdots & \\ a_p &= b_p \end{cases} \quad (162)$$

An algorithm to make the successive error coefficients zero has been proved! It yields the simple algebraic solution, numerator and denominator coefficients of the transfer function are equal pair by pair.

APPENDIX B

Sampled-Data Approximate Annihilator.

The formula
$$\frac{1 - B_n}{1 + B_n} = \left[\frac{1 - (1 - z)}{1 + (1 - z)} \right]^n \quad (162)$$

has interesting properties that are now investigated. First of all, although it appears similar to the aidentity improvement process (equation 50), no relation exists because $(1 - z)$ is not an approximate identity. The interest aroused by this form is that it generates approximate discrete convolution identity forms B_n where the coefficients of corresponding powers in numerator and denominator are equal. An approximate discrete convolution identity approaching the ideal form $1 + 0z + 0z^2 + \dots$ is thus obtained analytically.

The stability of B_n ensuring convergence to zero of the annihilator is investigated. Calculation of

$$\frac{1 - B_n(z)}{1 + B_n(z)} = \left(\frac{z}{2 - z} \right)^n \quad (163)$$

yields

$$B_n(z) = \frac{1 - \left(\frac{z}{2 - z} \right)^n}{1 + \left(\frac{z}{2 - z} \right)^n} \quad (164)$$

The poles of this transfer function are given by the solution of

$$\frac{z}{2 - z} = e^{j\theta} \quad (165)$$

where $\theta = (2k + 1) \pi/n$

which yields

$$z = 1 + j \tan(\theta/2) \quad (166)$$

with the imaginary part never zero. Whatever the number of iterations is, the approximate identity so obtained is stable since $|z| > 1$.

An n^{th} order approximate annihilator operator is defined as the difference between one and an approximate discrete convolution identity $B_n(z)$

$$O_n(z) = 1 - B_n(z) \quad (167)$$

$$O_n(z) = 1 - \frac{(2-z)^n - z^n}{(2-z)^n + z^n} \quad (168)$$

$$O_n(z) = \frac{2z^n}{(2-z)^n + z^n} \quad (169)$$

In the case of n even, numerator and denominator are of the same degree; in case of n odd, the denominator is of one degree less than the numerator.

An example for the case $n = 3$ yields

$$O_3(z) = \frac{2z^3}{8 - 12z + 6z^2} \quad (170)$$

Synthetic division provides the series expansion $(0 + 0z + 0z^2 + 0.25 z^3 + 0.375 z^4 + 0.375 z^5 + 0.28 z^6 + 0.14 z^7 + 0 z^8 - 0.12 z^9 - 0.17 z^{10} - 0.17 z^{11} - 0.13 z^{12} + 0 z^{12} + 0 z^{13} + 0.10 z^{14} + \dots)$

APPROXIMATE IDENTITY OPERATOR IN LINEAR CONTINUOUS
AND SAMPLED-DATA SERVOMECHANISMS

by

ANDRE JEAN RAULT

Ingenieur ARTS ET METIERS

PARIS, 1962

AN ABSTRACT OF
A MASTER'S REPORT

submitted in partial fulfillment of the

requirements for the degree

MASTER OF SCIENCE

Department of Electrical Engineering

KANSAS STATE UNIVERSITY
Manhattan, Kansas

1964

Usual servo design emphasizes stability analysis; later, servo performance is improved by compensation techniques. This study places admissibility first, and views the servo as an approximate identity operator. This latter concept is based on a zero error coefficient criterion and applied to linear continuous systems and sampled-data systems.

Improvement of performance is realized by Newton processes and servo structures are established. A root-locus technique, similar to Evans', is developed. It locates the poles and zeros of a system generated by a Newton process. All these procedures are established, in a parallel fashion, for linear continuous and sampled-data servos. This study enables systematic and algebraic design of continuous and sampled-data servos problems.