

DEVELOPMENT OF A HOE DRILL DEPTH CONTROL
SYSTEM FOR THE GREAT PLAINS REGION

by

RICHARD P. HATLEN

B.S., University of Wisconsin-Madison, December, 1985

A MASTER'S THESIS

submitted in partial fulfillment of the

requirements for the degree

MASTER OF SCIENCE

Department of Agricultural Engineering

KANSAS STATE UNIVERSITY
Manhattan, Kansas
1988

Approved by:

Mark D. Schrock

Major Professor

ACKNOWLEDGEMENTS

The author is indebted to numerous persons for their support and guidance throughout this research. The assistance, financial support, and facilities provided by the Kansas State University Agricultural Engineering Department, and the understanding of Dr. Stanley J. Clark, Acting Department Head, are greatly appreciated.

The continued guidance, support, and assistance offered by my Major Professor, Dr. Mark D. Schrock was invaluable. Through working with him I have gained personal knowledge in a number of areas which I feel will be useful to me in the future.

I would like to thank the scientists and staff of the four locations at which I had the opportunity to perform tests. Freddie Lamm, at the Colby Branch, Kansas State University Agricultural Experiment Station, was invaluable for the guidance, hospitality and help he offered. His guidance at this point set the tone for the rest of the tests which were to follow. Gerald Thierstein, at the Kansas State University Irrigation Experiment Field, Scandia, gave me the opportunity to run tests under true no-till conditions. Charles Norwood, at the Garden City Branch, Kansas State University Agricultural Experiment Station, offered conditions characterized by very dry loose soil. Carlyle Thompson, at the Fort Hays Branch, Kansas State University Agricultural Experiment Station, provided fields which had been undercut for weed control.

Thanks is given to Darrell Oard for his assistance and advice during the initial testing in the soil bin, construction, painting, and travel preparation. Doug Eubanks' help and ideas during the initial testing are also appreciated. The author would also like to thank Dr. Steven Young and Dr. John Slocombe, members of the graduate committee, for their

assistance.

During the time of my graduate studies, I was also given the opportunity to teach. I would like to thank Prof. Earl Baugher and Dr. John Slocombe for their guidance and support while under taking this task.

Special thanks is given to my parents, Richard and Elizabeth Hatlen, for their foresight, sacrifices, and ever present guidance.

TABLE OF CONTENTS

INTRODUCTION	1
REVIEW OF LITERATURE	4
Conservation Tillage	4
Obstacles to Adoption.	4
Incentives to Conform	5
Benefits of a Conservation System	9
Research and Development	10
INVESTIGATION	15
Objectives.	15
Design	15
Final Design by Component	20
Furrow Opener	20
Press Wheel	21
Mounting	22
Hydraulic System	23
Seed Metering	26
PRELIMINARY EVALUATION.	27
Soil Bin Experiment	27
Procedure	27
Results	30
FIELD EVALUATIONS	38
Colby Experiment	38
Procedure	39
Results	42
Scandia Experiment	46
Procedure	46
Results	50
Garden City Experiment	56
Procedure	56
Results	58
Fort Hays Experiment	64
Procedure	64
Results	65
DISCUSSION OF RESULTS.	71
CONCLUSIONS.	74
FUTURE RESEARCH.	75
REFERENCES	77

APPENDIX	79
Appendix A. Computer Program Used to Integrate the Area Under the Soil Displacement Curve	80
Appendix B. Opener Force Example Calculation	81
Appendix C. Colby Experiment Analysis of Variance Table	82
Appendix D. Scandia Experiment Analysis of Variance Table	84
Appendix E. Garden City Experiment Analysis of Variance Table	86
Appendix F. Fort Hays Experiment Analysis of Variance Table	88

LIST OF TABLES

Table 1. Fuel Required for Field Operations in Conventional, Chisel, and No-till Systems for Corn on Moderate Draft Soils.	7
Table 2. Energy Required to Produce Corn Under Conventional, Chisel, and No-till Systems.	8
Table 3. Effect of Tillage Equipment on Surface Residue.	9
Table 4. Penetrometer "Soil" Compaction Evaluation.	30
Table 5. Cohron Shear Graph "Soil" Condition Evaluation.	30
Table 6. Average Furrow Opener "Soil" Displacement.	32
Table 7. Average Furrow Opener and Press Wheel Combination "Soil" Displacement.	33
Table 8. Average Furrow Opener and Press Wheel Combination "Seeding Depth".	36
Table 9. Tip Depth Evaluation.	37
Table 10. Rainfall Received at the Colby Experiment Station Between June 16 and June 26, 1987.	41
Table 11. Three Meter Test Row Data With No Initial Irrigation.	43
Table 12. Three Meter Test Row Data With 2.5 cm of Initial Irrigation.	44
Table 13. Rainfall at the Scandia Irrigation Experiment Field, June and July 1987.	49
Table 14. Sorghum Three Meter Test Row Data with Preplant Tillage.	52
Table 15. Sorghum Three Meter Test Row Data with No Preplant Tillage.	53
Table 16. Sunflower Three Meter Test Row Data with Preplant Tillage.	54
Table 17. Sunflower Three Meter Test Row Data with No Preplant Tillage.	55
Table 18. Leading Row's Average Emergence.	60
Table 19. Back Row's Average Emergence.	61
Table 20. Leading Row's Average Seeding Depth.	62

Table 21. Back Row's Average Seeding Depth.	63
Table 22. Leading Row's Average Emergence.	67
Table 23. Back Row's Average Emergence.	68
Table 24. Leading Row's Average Seeding Depth.	69
Table 25. Back Row's Average Seeding Depth.	70

LIST OF FIGURES

Figure 1. Components Used to Perform Initial Penetration..	16
Figure 2. Methods Used for Furrow Opening and Seed Placement..	16
Figure 3. Components Used for Seed Imbedding..	17
Figure 4. Depth Control Wheels..	17
Figure 5. Types of Wheels Used for Furrow Closure..	18
Figure 6. First Opener Design Schematic..	19
Figure 7. Final Opener Design Schematic.	20
Figure 8. Opener Tips That Were Tested..	21
Figure 9. "V" Type and Inverted "V" Type Press Wheel..	22
Figure 10. KSU Hoe Drill.	23
Figure 11. Individual Opener Hydraulic Set-up.	24
Figure 12. Accumulator and Charging Valve.	25
Figure 13. Hydraulic System Schematic..	25
Figure 14. Soil Bin Processing Carriage..	28
Figure 15. Soil Bin Test Carriage.	29
Figure 16. Example "Soil" Surface Profile Photo from Test 1.	31
Figure 17. Example Digitized "Soil" Surface Profile from Test 1.	31
Figure 18. Example "Soil" Surface Profile Photo for the Inverted "V" Type Press Wheel from Test 2.	34
Figure 19. Example Digitized "Soil" Surface Profile for the Inverted "V" Type Press Wheel from Test 2.	34
Figure 20. Example "Soil" Surface Profile Photo for the "V" Type Press Wheel from Test 2..	35
Figure 21. Example Digitized "Soil" Surface Profile for the "V" Type Press Wheel from Test 2.	35
Figure 22. Colby Branch Agricultural Experiment Station Test Plot..	40
Figure 23. One pass at 5.1 cm with an offset disk harrow at the Scandia Irrigation Experiment Field.	47

Figure 24. No preplant tillage at the Scandia Irrigation Experiment Field.	48
Figure 25. Test Plot at the Garden City Branch Agricultural Experiment Station.	58
Figure 26. Test Plot at the Fort Hays Branch Agricultural Experiment Station.	65

INTRODUCTION

The use of and interest in conservation tillage systems has increased in recent years. Decreased production costs, increased profits, and soil and water conservation have been driving forces in this increase. Possibly the biggest incentive given to farmers to implement a conservation program is the Food Security Act of 1985. In general it states that "any person who, in any crop year, produces an agricultural commodity, without an approved conservation system, on . . . highly erodible land . . . after December 23, 1985, will be ineligible for" certain benefits provided by the United States Department of Agriculture (Federal Register, 1987).

When conservation techniques are used, there are several benefits. The erosive forces of water and wind are less disruptive because of the increased amount of residue left on and anchored to the soil. "Vegetative cover provides the most effective erosion control known" (Frederick et al., 1980). Depending on the tillage implement used and the number of passes, residue could potentially be reduced by as much as 90 percent (Herron, 1978). Not only can decreased erosion enable farmers to reduce soil losses to a tolerable limit but wind and water pollution are also reduced.

Decreased soil compaction is also a benefit of conservation tillage. Multiple passes across a field tends to cause soil compaction which can inhibit the ability of plant roots to penetrate the soil, and reduce their ability to absorb the necessary amounts of nutrients, water, and oxygen (Johnson and Henry, 1964). Compaction also restricts seedling emergence.

Fuel savings is another benefit of conservation tillage that became important in the early 1970's. As fuel prices increased so did the

incentive to reduce both preplant and postplant tillage. Research results from the Southwest Great Plains Research Station at Bushland, Texas, show that reduced tillage systems can save up to half the normal fuel costs (Frederick et al., 1980). However, decreased fuel and machinery costs do not necessarily mean a lower cost of production. According to Griffith and Parsons (1983) considerations such as the energy used in equipment manufacture and maintenance and in pesticide and fertilizer production are often overlooked in assessing the savings of tillage-planting systems. He suggests that cutting out even one trip across the field can save about 1/2 gallon of diesel fuel per acre.

Many comparison have been made on the effectiveness of different planters and their components. Schrock et al. (1982) evaluated the affect that seeding depth, opener design and press wheel treatment has on winter wheat seedling emergence. The experiments were run at various locations throughout Kansas. Schrock et al. (1982) concluded the following: 1) Spike openers operated with press wheels produced the best stands. 2) Increased seeding depth decreases emergence. 3) There is a variation in seeding depth between front and rear openers due to lateral soil movement when ranks of openers are used with narrow row spacings. 4) A sweep-runner design may produce acceptable stands and 5) there is an inherent advantage to using air seeders to deliver seed laterally. Schrock et al. (1982) also feels that there are advantages to the chisel type air seeder due to residue clearance.

In a similar study Allen et al. (1984) found that the moisture content and orientation of the residue, along with surface soil wetness, influenced a seeder's success in a no-till situation more than the amount

of residue. Overall, dry residue conditions presented fewer problems than wet conditions.

Although conservation tillage systems have had a certain amount of success they are not without problems. A review of literature revealed that most planters have problems associated with one or more of the following:

1. Residue clearance.
2. Penetration into hard soils.
3. Seeding depth control.
4. Adequate seed-to-soil contact.
5. Adaptability regarding soil moisture conditions.

A hoe drill was developed in the fall of 1986 primarily for use in the Great Plains Region. The suspension system used on this drill and the design of the opener have the potential to accurately place the seed in varying soil and residue conditions. Seeding trials were performed at various locations in Kansas during the summer and fall of 1987.

REVIEW OF LITERATURE

Conservation Tillage

The term conservation tillage has become a source of much confusion. Those in the field of agriculture often use the term interchangeably with minimum tillage, mulch tillage, reduced tillage and no-till. Generally conservation tillage can be defined as "any tillage system that reduces loss of soil or water relative to conventional tillage; often a form of non-inversion tillage that retains protective amounts of residue mulch on the surface" (Mannering et al., 1983). Fenster and Wicks (1976) use the term minimum tillage and state that it is designed to do three things; reduce energy requirements, protect soil from erosion and increase water intake. They go further and say that frequent or conventional tillage is not only unnecessary but is also costly. These costs could be in the form of machinery or the loss of nonrenewable resources such as fossil fuels and soil.

Conservation tillage really refers to a farming system. This system is looked upon by many as a new innovation in agriculture. In reality conservation tillage has been in existence since 1910 (Fenster and Wicks, 1976).

Obstacles to Adoption

Even though conservation tillage has been in use since 1910 and is growing in acceptance, there is still reluctance by many to take advantage of its many benefits. A serious obstacle is the lack of accurate and useful information. Because of the complexity of this system, more detailed and specific information is required than for

conventional tillage such as the timing, rate and type of fertilizer and chemicals to use. Providing the required information is not an easy task because there is not any one system that works well for every situation (King, 1983). The difficulty in choosing the proper system combined with the fear of failure and reduced yields prevent many from using conservation tillage. Even those who do attempt it are often times discouraged. According to Boots (1986), a Kansas farmer, this may be in part due to the fact that farmers underestimate the management required. Also they may observe decreased yields which could be caused by the location of their first trial field and not the tillage system used.

Incentives to Conform

Early in the history of conservation tillage, farmers in the Great Plains were motivated by the destruction seen during the Dust Bowl era. However, the demand for food during World War II and technological developments encouraged plowouts of land unsuitable for crop production (King, 1983).

While improved erosion protection is a major reason for conservation tillage, fuel savings is another benefit that became important in the early 1970's. As fuel prices increased so did the incentive to reduce both preplant and postplant tillage. Research results from the Southwest Great Plains Research Station at Bushland, Texas, show that reduced tillage systems can save up to half the normal fuel costs (Frederick et al., 1980). However, decreased fuel and machinery costs do not necessarily mean a lower cost of production. According to Griffith and Parsons (1983) considerations such as the energy used in equipment

manufacturing and maintenance and in pesticide and fertilizer production are often overlooked in assessing the savings of tillage-planting systems. He suggests that eliminating even one trip across the field can save about 1/2 gallon of diesel fuel per acre. Table 1 suggests an approximate fuel savings of 3.55 gallons of diesel fuel per acre when only changes in field operations are considered. However to evaluate the true savings one must take into account costs due not only to the field operation, but also those due to machinery and chemicals. Table 2 suggests a true savings of 3.59 gallons of diesel fuel per acre when no-till is used as opposed to conventional tillage (Griffith and Parsons 1983).

Table 1. Fuel Required for Field Operations in Conventional, Chisel, and No-till Systems for Corn on Moderate Draft Soils.*

<u>Tillage systems and field operations</u>	<u>Fuel required</u>
	gals./A
Conventional system	
Disk stalks	0.45
Moldboard plow	1.85
Disk	0.55
Field cultivate	0.60
Apply anhydrous	0.70
Plant	0.50
Cultivate	0.35
	<hr/> 5.00
Chisel system	
Chisel plow**	1.25
Disk	0.55
Field cultivation	0.60
Apply anhydrous	0.70
Plant	0.50
Cultivate	0.35
	<hr/> 3.95
No-till system	
Shred stalks	0.75
Apply liquid N	0.20
No-till plant	0.50
	<hr/> 1.45

* Source: Griffith and Parsons, 1983.
 **Assumes a coultter-chisel ie., chisel plow with gang of coultters at front to cut through trash.

Table 2. Energy Required to Produce Corn Under Conventional, Chisel and No-till Systems.*

Input item**	Diesel Fuel Equivalent when Tillage-planting System is-		
	Conventional	Chisel	No-till
	Gallons per Acre		
On-farm fuel	5.00	3.95	1.80
Machinery***	2.57	2.48	1.05
Herbicides	1.75	2.01	2.88
Nitrogen****	26.55	26.55	26.55
Total	35.87	34.99	32.28
Savings vs. conventional	(- -)	(0.88)	(3.59)

* Source: Griffith and Parsons, 1983.
 ** Only those energy-consuming input items likely to be altered by changing tillage practices are listed.
 *** For manufacture and maintenance.
 **** Application rate of 150 lbs./A as anhydrous ammonia for all three systems.

Possibly the biggest incentive given to farmers to implement a conservation program and take advantage of the benefits offered by conservation tillage is the Food Security Act of 1985. In general it states that "any person who, in any crop year, produces an agricultural commodity, without an approved conservation system, on . . . highly erodible land . . . after December 23, 1985, will be ineligible for" certain benefits provided by the United States Department of Agriculture (Federal Register 1987). An approved conservation system is one in which an agricultural commodity is produced on suitable land without excessive soil loss and does not detrimentally affect the environment.

Benefits of a Conservation System

When conservation techniques are used, one of the benefits is that soil erosion is decreased. The erosive forces of water and wind are less disruptive because of the increased amount of residue left on and anchored to the soil. "Vegetative cover provides the most effective erosion control known" (Frederick et al., 1980). Depending on the tillage implement used and the number of passes, residue could potentially be reduced by as much as 90 percent (Table 3). Not only can decreased erosion enable farmers to reduce soil losses to a tolerable limit but wind and water pollution are also reduced.

<u>Tillage Machine</u>	<u>Residue reduction per Operation (%)</u>
Subsurface machines	
Wide-blades and rodweeder	10
Mixing-type machines	
Heavy duty cultivators and field cultivators	25
Mixing and inverting disk machines	
One-way, tandem, offset disks	50
Inverting machines	
Moldboard and inclined disk plows	90

* Source: Herron, 1978.

Multiple passes across a field tends to cause compaction that could inhibit the ability of plant roots to penetrate the soil, and reduce their ability to absorb the necessary amounts of nutrients, water, and oxygen (Johnson and Henry, 1964). Compaction also restricts seedling emergence.

Finally, another major benefit is that of fuel conservation and the

decreased cost of production. These benefits were discussed earlier and are summarized in Tables 1 and 2.

Research and Development

A great deal of research has been done in the area of conservation tillage systems, more specifically on planters. These range from those that open only the seed slot to planters which till the area just prior to seed placement.

In 1978, Peterson et al. developed a chisel-planter for the Palouse region in Idaho. This planter performed tillage, liquid fertilizer injection and seed placement in a single pass. Tillage and fertilizer injection are accomplished by two ranks of chisel shanks. The fertilizer tube runs down the back of each shank. Following each shank is a packer wheel, double disk opener and a press wheel. The packer wheel provides a soil cover between the fertilizer and the seed. A double disk opener and press wheel perform the seeding operation. Seed distribution is accomplished by a standard fluted feed metering system. Trash clearance is a potential problem with this drill, however it did appear effective in reducing erosion and tillage energy requirements.

Bolton and Booster (1979) developed a rotary strip-tiller to seed dryland cereal grains. This unit tills a narrow planting strip, applies fertilizer and herbicides and distributes seed simultaneously. A spray boom was attached to the front of the tiller to apply herbicide. Also provisions were made to apply starter fertilizer to the seed zone. The rotary tiller tills a 100 mm strip to the depth of moisture. Seed placement is accurately controlled by use of a hoe drill and is covered

by 50-70 mm of soil in strips tilled to depths of up to 100-130 mm. This is possible because some of the soil is displaced to the center of the row. Grain yields using this system have compared favorably to those from plantings using conventional tillage methods.

Townsend and Bethge (1984) investigated the use of a powered rotating disk for no-till seed and fertilizer placement. Preliminary tests were done in a soil bin to determine the feasibility of the design. Subsequent tests were run in varying field conditions. The disk rotated opposite the direction of travel and the maximum average rotational power required was 2.6 kW at 540 rev/min for a forward travel speed of 5.2 km/h and a cutting depth of 50 mm in heavily compacted soil. The design was able to place the fertilizer at an average depth of 46.8 mm and the seed at an average depth of 28.8 mm. The layer of soil separating the seed and fertilizer averaged approximately 18 mm. Excellent emergence and plant growth were achieved through relatively heavy residue. There did not appear to be any problems associated with toxic substances and yield compared favorably with other seeding methods.

Case IH developed and tested the 8500 Air Drill (Pollard et al., 1986). This drill is a 45 ft. folding grain drill available in row spacings of 7, 10 and 12 inches. It uses a pneumatic seed delivery system and hoe-type furrow openers. It offers the following claimed capabilities; transportability due to its hydraulically folded frame, easy hopper filling and flexibility due to the split hopper design and height, less maintenance, no-till capability, improved depth control and a monitoring system. Testing proved that the 8500 Air Drill was reliable. Also claims

were made that it functioned well under most conditions, however no emergence or yield data were reported.

In 1987 Rogers and Baron developed a punch seeder. This seeder was matched with an air delivery system which delivered the seed through the punch selection valve and punch. Preliminary work was done in a soil bin where a final self-cleaning design was chosen. Field trials were later run and it was determined that the punches required approximately a 25 kg load to penetrate 3 cm into a stubble field. One problem that Rogers had was that much of the seed was dropped on the soil surface.

Many comparison studies have been done on the effectiveness of different planters and their components. Wilkins et al. (1981) evaluated the affect that six different grain drill openers had on seedling emergence. The openers tested were a single disk, double disk, hoe, and three variations of a John Deere HZ. The opener used was found to influence the soil moisture profile within the seedbed, soil bulk density at seed depth, and seed distribution. Of these factors, soil moisture proved to be the most crucial. The importance of good seed distribution was in the number of seeds placed in contact with moist soil. Soil bulk density did not alter seedling emergence. The Johnson modified HZ and hoe openers produced the best seedling emergence. Disk openers performed poorly due to fine dry soil mulch sifting into the seed zone after seeding.

Tests performed (Payton et al., 1979) on several grain drill combinations, fertilizer placement methods, and grain drill types showed that fertilizer placed below the seed was advantageous for both spring and winter wheat. In spring wheat plots, weed populations were

decreased when fertilizer was placed below the seed rather than broadcast. The use of coulters did not increase yields but contributed to better overall machine performance. Double disk openers had a yield advantage on pea residue and in general a yield advantage was realized by openers that cleared the seed row of residue. Finally, in all cases heavy chaff detracted from production as did poor weed control, which proved to be critical to success.

In a similar study Allen et al. (1984) found that the moisture content and orientation of the residue, along with surface soil wetness, influenced a seeder's success in a no-till situation more than the amount of residue. Overall, dry residue conditions presented fewer problems than wet conditions.

Schrock et al. (1982) evaluated the affect that seeding depth, opener design and press wheel treatment has on winter wheat seedling emergence. The experiments were run at various locations throughout Kansas. Schrock et al. concluded the following: Spike openers operated with press wheels produced better stands. Increased seeding depth decreases emergence. There is a variation in seeding depth between front and rear openers due to lateral soil movement when ranks of openers are used and with narrow row spacings. A sweep-runner design may produce acceptable stands and there is an inherent advantage to using air seeders to deliver seed laterally. Schrock also feels that there are advantages to the chisel type air seeder due to residue clearance.

Due to the need for compliance to the Food Security Act of 1985 and the production cost benefits, the future farming system will involve conservation tillage (Borden and Wittrock, 1987). According to Borden

and Wittrock (1987) rotary tillage is the most efficient and versatile system available. This is because of its ability to perform under a wide variety of weather conditions. In the future, engineers will develop equipment to encourage conservation tillage and growers will be more open-minded to the concept.

INVESTIGATION

Objectives

The objective of this research was to develop a seeder that produces good stands and conserves soil and water. This seeder should be versatile and capable of operating in variable soil conditions, have the ability to penetrate the soil surface without excessive weight, accurately place the seed in moist soil and operate in heavy residue. The review of literature revealed that most planters have problems associated with one or more of the following:

1. Residue clearance.
2. Penetration into hard soils.
3. Seeding depth control.
4. Adequate seed-to-soil contact.
5. Adaptability regarding soil moisture conditions.

After the conditions under which the drill must be able to operate and the goals of the unit were identified, different press wheel / opener configurations were considered.

Design

Many commercial components are currently available, however the design was not limited to these. Basically these components can be classified into five areas based on their function. They are:

1. Components used to perform initial penetration.
2. Furrow opening devices.
3. Components used to imbed the seed.
4. Depth control devices.

5. Wheels used to close the furrow.

Examples of these components are shown in Figures 1-5 respectively.

These components and variations of them were used during the initial investigation.

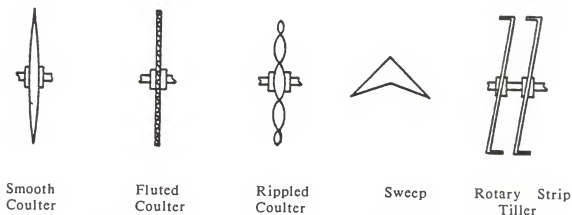

Figure 1. Components Used to Perform Initial Penetration.
Source: Suderman, 1981.

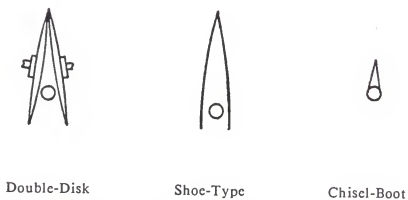

Figure 2. Methods Used for Furrow Opening and Seed Placement.
Source: Suderman, 1981.

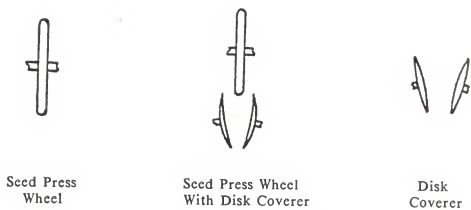

Figure 3. Components Used for Seed Imbedding.
Source: Suderman, 1981.

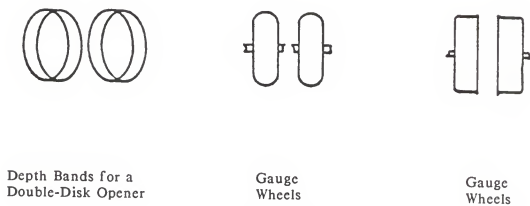

Figure 4. Depth Control Wheels.
Source: Suderman, 1981.

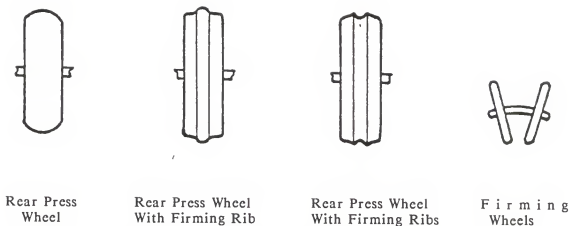

Figure 5. Types of Wheels Used for Furrow Closure.
Source: Suderman, 1981.

Many trips were taken to the test field to observe the soil flow and depth control characteristics of different opener configurations prior to the final design. It was concluded that a hoe-type opener had the potential to best achieve the goals outlined. One of the basic configurations considered was a straight shank hoe opener with a depth control wheel attached to one side. A single press wheel was mounted directly behind the shank. The unit as a whole was supported by a parallel arm linkage (Figure 6). This unit seemed to have desirable soil flow characteristics and performed the functions of depth control and furrow closure well in hard dry soil. However, in conditions where there was loose soil and medium to heavy residue, material would build-up in front of the depth control wheel. When the soil conditions were moist the press wheel did not adequately close the furrow or embed the seed.

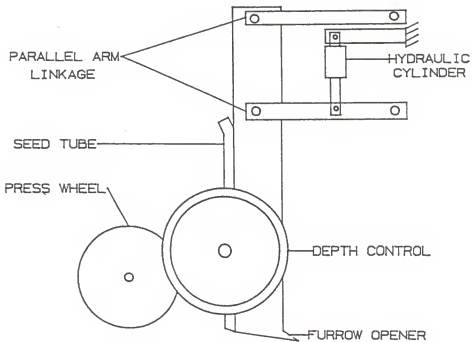

Figure 6. First Opener Design Schematic.

The final design is a hoc-type drill (Figure 7) which will be referred to as the KSU Hoe Drill. The furrow opener is a straight shank with provisions to use different opener tips. Each opener is attached to a tool bar by means of a parallel arm linkage. The depth is controlled and the furrow is closed by a reversible wheel connected to the opener shank. A hydraulic system is used to supply the needed downward force on each opener and to raise the entire unit for transport.

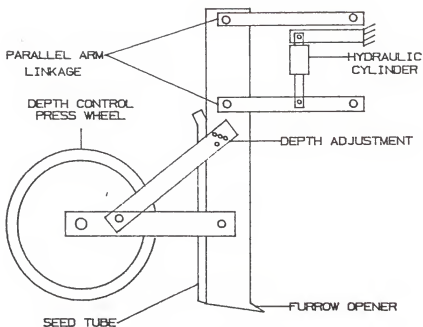

Figure 7. Final Opener Design Schematic.

Final Design by Component

Furrow Opener

The opener is a straight shank hoe-type opener. It was designed to allow for the testing of different opener tips. The bottom portion, to which the different tips are mounted, is detachable by removing two connecting bolts. This allowed tips to be changed in both the soil bin and test field with a minimal amount of tools and time. Four different tips were tested initially in the soil bin. An ACRA-Plant "Z-6" drill shoe no. 7100-60 point, ACRA-Plant standard anhydrous knife no. 7000-41, ACRA-Plant "HZ" drill shoe no. 7120-00, and a Pacific Alloy Castings, Inc. "C-14" fertilizer knife (Figure 8). The ACRA-Plant "Z-6" and the Pacific Alloy Castings, Inc. "C-14" were selected for field testing. They were chosen based on the results of the soil bin experiment. Also the "Z-6" is a tip commonly used for this application.



ACRA-Plant "Z-6"	Pacific Alloy Company "C-14"	ACRA-Plant "HZ"	ACRA-Plant Anhydrous Knife
---------------------	---------------------------------	--------------------	-------------------------------

Figure 8. Opener Tips That Were Tested.

The straight shank opener is an advantage where large amounts of residue are encountered. This is because it improves the possibility of obtaining good seed-to-soil contact by decreasing problems related to residue hair-pinning into the furrow opening as with single or double disk openers. This can be a limiting factor in seeding success.

Press Wheel

A reversible wheel is used to control seeding depth and to perform the function of furrow closure (Figure 9). In dry soil conditions the "V" type configuration is used. The wheel tip firms the soil over the seed and the sloped rim controls depth by riding on the furrow opening's edge. When conditions are wetter, the two halves of the wheel are put back to back, in an inverted "V" type configuration. The outside rim of

the wheel rides on each side of the furrow opening to control depth while its inside slopes firm the soil around the seed. This has an added advantage of not compacting the soil directly over the seed.

The wheel is mounted on a stub shaft to permit the repositioning of its halves. A mounting bracket, attached to the shank by means of a pin connection to allow vertical movement, supports the hub which houses the stub shaft. Depth adjustment is provided by a third member fastened to the wheel mounting bracket and the shank. The hole pattern in the depth adjusting member and shank enable seeding depth adjustments in increments of 0.6 cm.

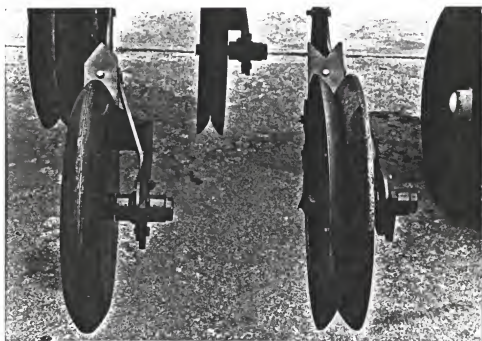

Figure 9. "V" Type and Invert "V" Type Press Wheel.

Mounting

This unit was designed to seed through large amounts of residue and maintain a nearly constant seeding depth. The two ranks of seeding units

keep the width of each unit to a minimum and allow for greater residue clearance which enables the row spacing to be as narrow as 15 cm, while maintaining good trash clearance. Each seeding unit is mounted with a parallel arm linkage. This linkage enables the seeding units to move independent of each other vertically without moving horizontally. Also the relatively short distance between the center of the press wheel and the shank aid in maintaining a nearly constant seeding depth over varying topography (Figure 10).

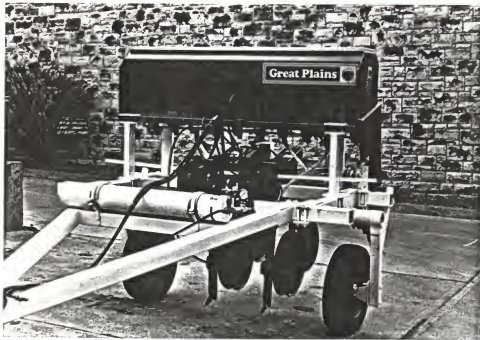

Figure 10. KSU Hoe Drill.

Hydraulic System

This seeding unit is capable of adjusting to varying soil compaction levels. Downward force is controlled by individual hydraulic cylinders (Figure 11). The top of these cylinders are connected in parallel to a manifold which is connected in series to an accumulator (Figure 12). The

accumulator is initially charged with nitrogen gas and a line from the tractor together with a shut off valve is used to adjust the accumulator pressure in the field providing a means for controlling pressure over each opener and allowing them to float independently. Another hydraulic circuit connects the bottom of each cylinder, including the main cylinder, in parallel to a second manifold which is linked to the tractor hydraulics. This enables the trailer and each unit to be raised for transport. A hydraulic schematic for a four row planter is shown in Figure 13.

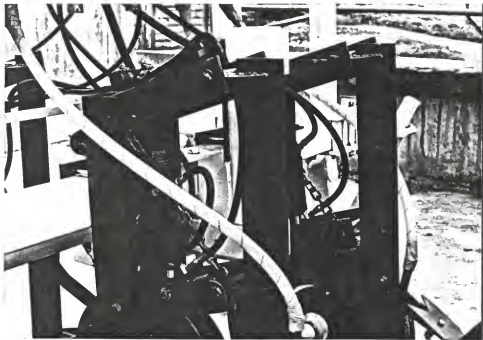

Figure 11. Individual Opener Hydraulic Set-up.

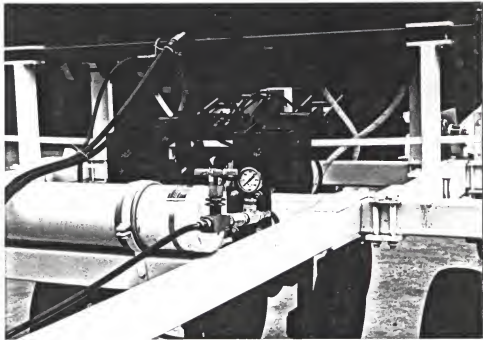

Figure 12. Accumulator and Charging Valve.

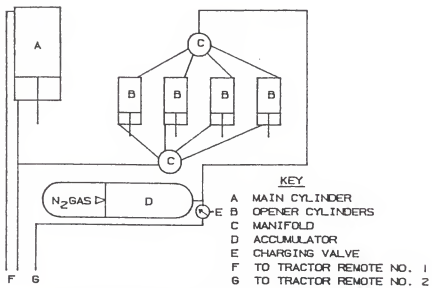

Figure 13. Hydraulic System Schematic.

Seed Metering

Seed metering devices were not considered in the design. While they are a very important component of any seeding unit, it was felt that there are many units already in production which perform this task well. A Great Plains Solid Stand fluted cup seed metering device was used in this study.

PRELIMINARY EVALUATION

Soil Bin Experiment

Preliminary analysis of the final design was done in a soil bin located at KSU's Agricultural Engineering Department. Two tests were conducted. The first was an evaluation of four different opener tips. In this test the amount of "soil" displaced by each opener tip was compared. It was felt that the tip which displaced the least amount of soil would have an advantage for this design. Test 2 was an evaluation of a combination of two different tips, two press wheel configurations, and one downward force at two seeding depths. In this experiment the "soil" displacement and apparent "seed" placement depth was evaluated.

Procedure

The testing facility is approximately 15 m long, 1.2 m wide and 61 cm tall. It contains an artificial "soil" that is 45 cm deep and is composed of sand, clay and mineral oil. An artificial "soil" is used to alleviate problems in maintaining a consistent "soil" moisture condition. The "soil" is conditioned between each run by means of a processing carriage consisting of a rototiller, leveling blade and a roller (Figure 14). This provides a means by which consistent and repeatable "soil" conditions can be attained.

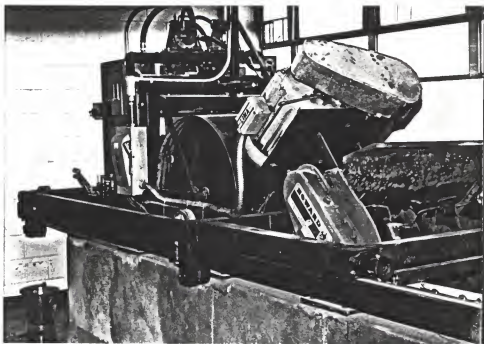

Figure 14. Soil Bin Processing Carriage.

A single seeding unit which consisted of the parallel arm mounting, hoe opener, press wheel and opener hydraulic system, was mounted to the test carriage. The test carriage has a hydraulic system capable of generating 14.9 kW and is able to change the position of the device being tested in both a vertical and horizontal direction (Figure 15). The tests were run at approximately 5 km/h.

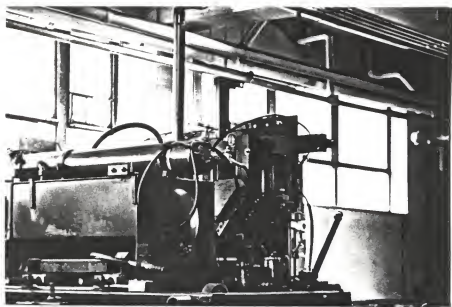

Figure 15. Soil Bin Test Carriage.

An attempt was made to make the condition of the "soil" consistent throughout the two tests. Before each run, the "soil" was tilled with the rototiller, leveled, and rolled six times. Penetrometer and Cohron Shear Graph readings were taken at various locations after run numbers 1 and 8 for both tests as a check on the "soil" condition. These results are summarized in Tables 4 and 5. After each run a piece of sheet metal with a 2.5 cm by 1.25 cm grid was inserted into the "soil" at three locations. A photo was then taken of the "soil" surface profile for use in evaluating the "soil" displacement. The camera was mounted three m ahead of and 41 cm above the point of grid insertion.

Table 4. Penetrometer "Soil" Compaction Evaluation.

<u>Test No.</u>	<u>Reading Depth (cm)</u>	<u>Average Reading (kPa)</u>
1	0.0	280.8
1	2.5	528.8
1	5.0	635.6
1	7.5	637.3
1	10.0	585.7
1	12.5	544.3
1	15.0	503.0
2	0.0	249.8
2	2.5	421.0
2	5.0	518.5
2	7.5	551.5
2	10.0	525.0
2	12.5	475.1
2	15.0	444.1

Table 5. Cohron Shear Graph "Soil" Condition Evaluation.

<u>Test No.</u>	<u>Run No.</u>	<u>Soil Apparent Cohesion (kPa)</u>	<u>Angle of Soil Internal Friction (degrees)</u>
1	1	3.4	30
1	8	6.9	34
2	1	3.4	31
2	8	6.9	34

Results

In the first Test four different tips were tested. An ACRA-Plant "Z-6" drill shoe no. 7100-60 point, ACRA-Plant standard anhydrous knife no. 7000-41, ACRA-Plant "HZ" drill shoe no. 7120-00, and a Pacific Alloy Castings, Inc. "C-14" fertilizer knife. Tests were run at depths of 3.8 and 7.6 cm. Figure 16 shows an example of a "soil" surface profile photo from Test 1. The photos were then digitized (Figure 17) and the "soil"

displaced by the different tips was compared. Appendix A contains the computer program used to determine the "soil" displacement.



Figure 16. Example "Soil" Surface Profile Photo from Test 1.

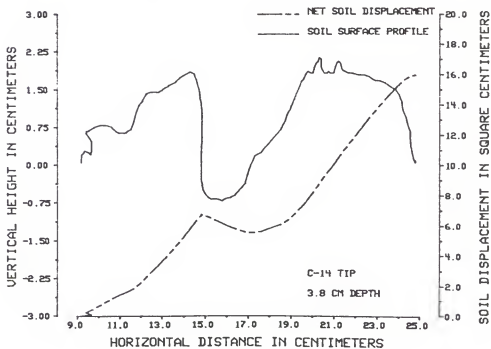

Figure 17. Example Digitized "Soil" Surface Profile from Test 1.

In the first Test the differences in the amount of "soil" displaced were not large, however the results did show that as depth increases the amount of "soil" displaced also increases (Table 6).

Table 6. Average Furrow Opener "Soil" Displacement.

<u>Tip</u>	<u>Depth (cm)</u>	<u>Soil Displaced in Square cm</u>
C-14	3.8	15.61
HZ	3.8	18.83
Z-6	3.8	16.64
7000-41	3.8	15.42
C-14	7.6	30.70
HZ	7.6	34.44
Z-6	7.6	42.83
7000-41	7.6	28.38

Test 2 evaluated the interaction between the ACRA-Plant "Z-6" and the Pacific Alloy Castings, Inc. "C-14" tips, with the "V" and inverted "V" type press wheel, at two "seeding depths". The four treatment combinations were evaluated at 3.8 and 7.6 cm "seeding depths" with a constant downward force of approximately 1182 N (266 lbs), which corresponds to an accumulator pressure of about 655 kPa (Appendix B). The following is a list of their treatment numbers and definitions:

1. Hoe opener with a Pacific Alloy Castings "C-14" tip and a "V" type press wheel.
2. Hoe opener with a Pacific Alloy Castings "C-14" tip and an inverted "V" type press wheel.
3. Hoe opener with an ACRA-Plant "Z-6" tip and a "V" type press wheel.
4. Hoe opener with an ACRA-Plant "Z-6" tip and an inverted "V" type press wheel.

After each run the procedure followed in Test 1 was used to measure the "soil" displacement (Table 7). The "V" type press wheel appeared to displace more "soil" than the inverted "V" type wheel. These results match the physical features and size of the furrow left by each wheel. Also the depth and "soil" displacement were directly related as they were in Test 1. Figures 18 through 21 show examples of "soil" surface profile photos for each of the two press wheel configurations and their corresponding digitized data.

Table 7. Average Furrow Opener and Press Wheel Combination "Soil" Displacement.

<u>Trt*</u>	<u>Depth (cm)</u>	<u>Soil Displaced in Square cm</u>
1	3.8	6.00
	7.6	15.61
2	3.8	3.03
	7.6	9.03
3	3.8	13.22
	7.6	21.03
4	3.8	4.06
	7.6	14.00

* 1. Pacific Alloy Castings "C-14" tip and a "V" type press wheel.
 2. Pacific Alloy Castings "C-14" tip and an inverted "V" type press wheel.
 3. ACRA-Plant "Z-6" tip and a "V" type press wheel.
 4. ACRA-Plant "Z-6" tip and an inverted "V" type press wheel.

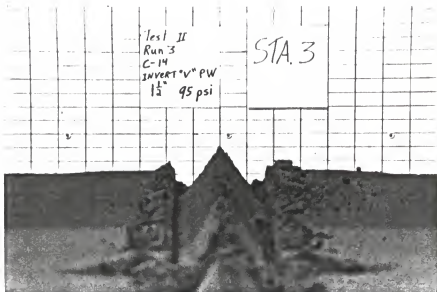

Figure 18. Example "Soil" Surface Profile Photo for the Inverted "V" Type Press Wheel from Test 2.

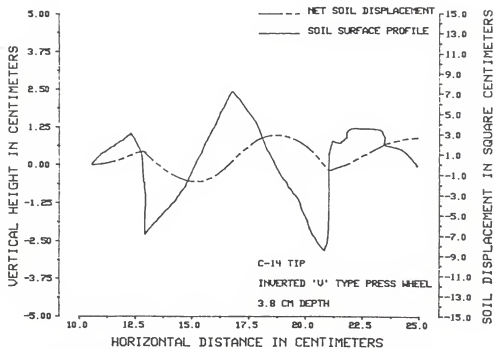

Figure 19. Example Digitized "Soil" Surface Profile for the Inverted "V" Type Press Wheel from Test 2.

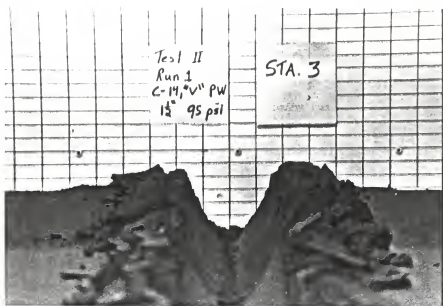

Figure 20. Example "Soil" Surface Profile Photo for the "V" Type Press Wheel from Test 2.

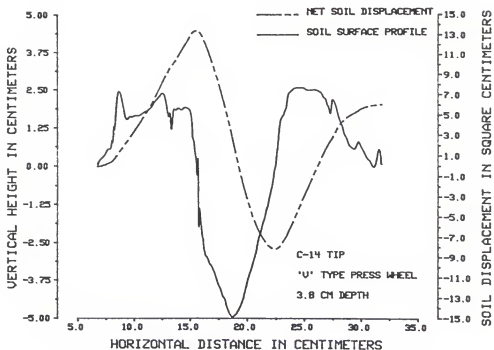

Figure 21. Example Digitized "Soil" Surface Profile for the "V" Type Press Wheel from Test 2.

The ability to maintain a constant "seeding depth" was evaluated by "planting" a monofilament fishing line during Test 2 for each run. "Soil" was excavated at three locations and the depth of the fishing line was recorded. Tip depth was evaluated at the beginning and end of each run. Tables 8 and 9 show the results of these evaluations. As they indicate, this design appears to be able to maintain a consistent depth of soil over the seed with variations in tip depth. Differences in the depth of penetration between the two types of press wheels were also noted.

Table 8. Average Furrow Opener and Press Wheel Combination "Seeding Depth".

Trt*	Nominal Depth (cm)	Average Depth (cm)	Standard Deviation
1	3.8	4.02	0.37
	7.6	6.98	0.55
2	3.8	4.77	0.55
	7.6	6.98	0.55
3	3.8	3.60	0.18
	7.6	7.20	0.18
4	3.8	4.98	0.48
	7.6	5.82	0.66

* 1. Pacific Alloy Castings "C-14" tip and a "V" type press wheel.
 2. Pacific Alloy Castings "C-14" tip and an inverted "V" type press wheel.
 3. ACRA-Plant "Z-6" tip and a "V" type press wheel.
 4. ACRA-Plant "Z-6" tip and an inverted "V" type press wheel.

Table 9. Tip Depth Evaluation.

Trt*	"Seeding Depth" (cm)	Beginning Depth (cm)	Ending Depth (cm)
1	3.8 7.6	8.57 13.34	6.35 12.70
2	3.8 7.6	3.81 6.35	** 5.08
3	3.8 7.6	8.26 14.29	6.35 11.11
4	3.8 7.6	5.08 6.35	** 5.08

** Unable to obtain due to "soil" conditions.

* 1. Pacific Alloy Castings "C-14" tip and a "V" type press wheel.
 2. Pacific Alloy Castings "C-14" tip and an inverted "V" type press wheel.
 3. ACRA-Plant "Z-6" tip and a "V" type press wheel.
 4. ACRA-Plant "Z-6" tip and an inverted "V" type press wheel.

As one would expect, as the depth of operation increased so did the amount of soil displaced. This was true for both tests. It was also noted that the treatments which used the inverted "V" type press wheel had a larger net amount of soil displaced, however this result could be due to the fact that the "V" type press wheel left a significantly deeper furrow. The results pertaining to the depth at which the "seed" was placed indicate that this design had the ability to maintain a nearly constant "seeding depth" under these conditions.

FIELD EVALUATIONS

Four different field experiments were run to evaluate the performance of this hoe drill design. They were run at: The Colby Branch Agricultural Experiment Station in Colby, Kansas; Scandia Irrigation Agricultural Experiment Field in Scandia, Kansas; Garden City Branch Agricultural Experiment Station in Garden City, Kansas; and the Fort Hays Branch Agricultural Experiment Station in Hays, Kansas.

Colby Experiment

Two types of drills were evaluated in western Kansas on a Kieth silt loam soil in terms of their ability to seed sorghum. Four different configurations of the KSU Hoe Drill developed at Kansas State University and a John Deere 71 double disc opener were tested. Both were evaluated at depths of 2.5 and 6.4 cm. These ten different treatments were compared in terms seedling emergence on a seedbed prepared with conventional tillage methods.

An analysis was done using SAS version 5.16 to evaluate the effect of each factor within the different treatments. The irrigation treatment, furrow opener used, and the depth of seeding were significant factors in determining emergence. An analysis was also performed on an uniformity index which attempted to test the effect that the two different types of seed metering mechanisms had on emergence. These results did not prove to be significant, therefore it was concluded that the differences in emergence were due to the treatments administered.

PROCEDURE

The KSU Hoe Drill prototype was fabricated in June, 1987. An experiment was laid out in western Kansas at the Kansas State University Agricultural Experiment Station in Colby. For this experiment the seeders were set up to plant four 61 cm rows. The experimental design was a split plot with three replications. Within each replication the ten treatments were randomly assigned. One half of each replication received an initial irrigation after planting to test the effect of crusting. Test plots were located in one quarter of a center pivot irrigated field to which an irrigation of 2.5 cm was applied prior to planting (Figure 22). The soil was prepared using conventional tillage methods (ie. with a plow, disk, mulcher etc.). No tillage operations were performed after June 6, 1987. Funks G 102f forage sorghum seed was used at a seeding rate of approximately 2.2×10^5 seeds per hectare. At 88% emergence a plant population of 1.9×10^5 would be expected. Seeding rates were checked by catching seeds dropped during 30 m runs. The rate quoted is an average of these calibration trials.



Figure 22. Colby Branch Agricultural Experiment Station Test Plot.

Planting was scheduled for June 12, 1987 but was delayed by rain until June 16, 1987. Table 10 shows the rain received before and during the experiment. On the planting date the topsoil was firm due to the settling caused by the rain received. Two soil samples were taken for each replication on June 16, 1987 to determine the moisture content of the soil. The average soil moisture content was 18.3 percent on a dry weight basis. On June 17, 1987 alternate halves of each of the three replications received an irrigation of 2.5 cm. This was the only irrigation the test plots received during the experiment.

Table 10. Rainfall Received At The Colby Experiment Station Between June 16 And June 26, 1987.*

<u>Date</u>	<u>Rainfall (cm)</u>
June 19	0.79
June 21	0.53
June 24	1.75
June 25	0.13

* Source: Colby Branch Agricultural Experiment Station

A 3 meter test row was counted for each treatment in each replication under both irrigated and non-irrigated conditions. At 88% emergence one would expect each test row to have a maximum of 36 plants. Also a random 0.6 meter section in each test row was counted to try to determine the uniformity of seeding (UNF) and was used to calculate an uniformity index (IND).

UNF: plants per random 0.6 m section within a test row

ROW3: plants per 3 m test row

IND: seeding uniformity index

$IND = (UNF * 5) / ROW3$

The following is a list of the ten different treatment identification numbers and their corresponding definitions:

1. John Deere 71 double disk opener, chevron press wheel, 2.5 cm seeding depth.
2. John Deere 71 double disk opener, chevron press wheel, 6.4 cm seeding depth.
3. Hoe opener with a Pacific Alloy Castings "C-14" tip, "V" type press wheel, 2.5 cm seeding depth.
4. Hoe opener with a Pacific Alloy Castings "C-14" tip, "V"

- type press wheel, 6.4 cm seeding depth.
5. Hoe opener with a Pacific Alloy Castings "C-14" tip, inverted "V" type press wheel, 2.5 cm seeding depth.
 6. Hoe opener with a Pacific Alloy Castings "C-14" tip, inverted "V" type press wheel, 6.4 cm seeding depth.
 7. Hoe opener with an ACRA-Plant "Z-6" tip, "V" type press wheel, 2.5 cm seeding depth.
 8. Hoe opener with an ACRA-Plant "Z-6" tip, "V" type press wheel, 6.4 cm seeding depth.
 9. Hoe opener with an ACRA-Plant "Z-6" tip, inverted "V" type press wheel, 2.5 cm seeding depth.
 10. Hoe opener with an ACRA-Plant "Z-6" tip, inverted "V" type press wheel, 6.4 cm seeding depth.

All of the hoe-type treatments were variations of the KSU Hoe Drill. The downward force was held constant for all of the hoe drill treatments at approximately 938 N (210 lbs) which corresponds to a pressure of about 413 kPa in the accumulator (Appendix B).

Results

A final evaluation was made on July 8, 1987. The average emergence and uniformity index for the different treatments and irrigation levels are shown in Tables 11 and 12.

Table 11. Three Meter Test Row Data With No Initial Irrigation.**

Trt*	Average Emergence (plants/row)	Uniformity Index	Number of Observations
1	20.7	1.0	3
2	16.3	1.3	3
3	31.7	1.1	3
4	25.0	1.1	3
5	33.3	1.3	3
6	23.7	0.9	3
7	27.7	0.9	3
8	27.3	1.6	3
9	29.7	1.3	3
10	23.3	0.9	3

- * 1. Double disk opener, chevron press wheel at 2.5 cm.
 2. Double disk opener, chevron press wheel at 6.4 cm.
 3. "C-14" hoe opener, "V" type press wheel at 2.5 cm.
 4. "C-14" hoe opener, "V" type press wheel at 6.4 cm.
 5. "C-14" hoe opener, inverted "V" type press wheel at 2.5 cm.
 6. "C-14" hoe opener, inverted "V" type press wheel at 6.4 cm.
 7. "Z-6" hoe opener, "V" type press wheel at 2.5 cm.
 8. "Z-6" hoe opener, "V" type press wheel at 6.4 cm.
 9. "Z-6" hoe opener, inverted "V" type press wheel at 2.5 cm.
 10. "Z-6" hoe opener, inverted "V" type press wheel at 6.4 cm.

** Colby Branch Agricultural Experiment Station,
 July 8, 1987

** Sorghum

Table 12. Three Meter Test Row Data With 2.5 cm of Irrigation.**

Trt*	Average Emergence (plants/row)	Uniformity Index	Number of Observations
1	10.3	1.0	3
2	12.3	0.9	3
3	29.7	1.1	3
4	23.7	0.8	3
5	31.0	1.1	3
6	20.3	1.2	3
7	29.3	0.9	3
8	24.0	1.3	3
9	20.7	0.7	3
10	19.7	0.8	3

- * 1. Double disk opener, chevron press wheel at 2.5 cm.
 2. Double disk opener, chevron press wheel at 6.4 cm.
 3. "C-14" hoe opener, "V" type press wheel at 2.5 cm.
 4. "C-14" hoe opener, "V" type press wheel at 6.4 cm.
 5. "C-14" hoe opener, inverted "V" type press wheel at 2.5 cm.
 6. "C-14" hoe opener, inverted "V" type press wheel at 6.4 cm.
 7. "Z-6" hoe opener, "V" type press wheel at 2.5 cm.
 8. "Z-6" hoe opener, "V" type press wheel at 6.4 cm.
 9. "Z-6" hoe opener, inverted "V" type press wheel at 2.5 cm.
 10. "Z-6" hoe opener, inverted "V" type press wheel at 6.4 cm.

** Colby Branch Agricultural Experiment Station,
 July 8, 1987

** Sorghum

An analysis of variance was performed on the results of the July 8th evaluation at a significance level of alpha equal to 0.05 (Appendix C). First, the effect that the variables within a treatment and irrigation had on emergence were compared. The level of irrigation, furrow opener, and the seeding depth all had a significant effect on emergence. Upon closer investigation it was determined that the treatments which used a hoe-

type furrow opener at a seeding depth of 2.5 cm attained higher emergence levels than did those which received no initial irrigation. Based on the amount and frequency of rainfall received at this location the effect of the initial irrigation was probably not due to surface crusting. Its effect could have been due to the higher cumulative level of soil moisture which may have caused decreased infiltration and therefore increased runoff and erosion. This increased erosion had the effect of covering the germinated seeds which had not fully emerged.

The fact that the hoc-type furrow opener and seeding depth of 2.5 cm attain higher emergence may be due to the accuracy and depth at which the seed was placed and the seed-to-soil contact. An analysis of the uniformity index proved that the differences were not due to non-uniform seeding.

Scandia Experiment

Five types of drills were evaluated in northern Kansas at the Scandia Irrigation Agricultural Experiment Field on a Crete silt loam soil. Four different configurations of the KSU Hoe Drill developed at Kansas State University, Buffalo-Till Planter, John Deere MaxEmerge II, KSU Disk Furrower Planter, and the KSU Lister Furrower Planter were tested. All were evaluated at a seeding depth of approximately 2.5 cm. The treatments consisted of the planters, two crops (grain sorghum and sunflowers) and two tillage systems. All five types of drills were tested with the no-till system in their ability to seed sorghum and sunflowers. Under the tillage system, which consisted of one pass at 5.1 cm with an offset disk harrow, the John Deere MaxEmerge II and hoe drill treatment numbers 5 and 6 were not evaluated for either crop. An analysis was performed using SAS version 5.16 comparing all of the treatments with respect to the crop planted and the tillage system used. The planter used proved to be significant in determining emergence. The tillage system and its interaction with the planter were not significant factors.

Procedure

The prototype seeding unit used at the Colby Experiment Station was configured to plant three 76 cm rows for this experiment. Test plots were located in Field 9 which had approximately 11,000 kgs per hectare of wheat straw. The experimental design was a randomized complete block designed with three replications. Treatments, that is the planter tillage combination, were randomly assigned within each replication. The soil was prepared using one of two tillage systems, either one pass with

an offset disk harrow at 5.1 cm (Figure 23) or no preplant tillage (Figure 24). Stauffer 515 sorghum seed and Triumph 565 sunflower seed was used. The seeding rates were approximately 1.1×10^5 and 5.4×10^4 seeds per hectare respectively. At 86% emergence the expected plant populations would be 9.8×10^4 and 4.7×10^4 . Seeding rates were checked by catching seeds from each seeding tube used. The rates quoted are averages of the calibration trials. Some difficulty was experienced in calibrating the fluted cup seed metering device due to the low seeding rates required and to the size and weight of the sunflower seed.



Figure 23. One pass at 5.1 cm with an offset disk harrow at the Scandia Irrigation Experiment Field.

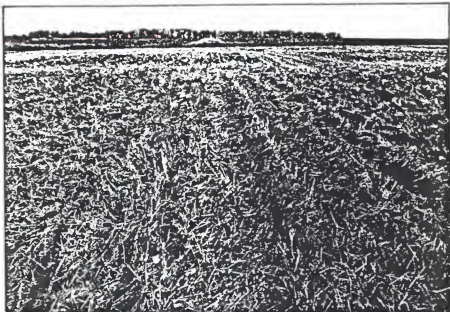

Figure 24. No preplant tillage at the Scandia Irrigation Experiment Field.

Planting was delayed by rain and took place June 25, 1987. Table 13 shows the rainfall amounts for June and July. On the planting date the soil moisture content was at approximately the plastic limit, 81.6% on a dry weight basis, and the wheat straw residue was tough.

Table 13. Rainfall at the Irrigation Experiment Field, Scandia. June and July 1987.*

<u>Date</u>	<u>Rainfall (cm)</u>
June 1	0.51
June 2	2.01
June 8	0.61
June 10	0.41
June 11	0.42
June 15	1.40
June 18	0.51
June 22	1.60
June 24	0.10
June 27	1.60
June 28	3.00
June 29	0.79
July 8	1.50
July 12	1.40

* Source: Scandia Irrigation Experiment Field.

Two 3 meter test rows were counted for each treatment in each replication. At 86% emergence one would expect each test row in the plots where sorghum and sunflowers were planted to have a maximum of 22 and 9 plants respectively.

The following is a list of the eight different treatment identification numbers and their corresponding definitions:

1. Buffalo 4500 Till Planter - Depth control disk in front of slot seed furrow opener. Press wheel in furrow followed by covering disks and tine incorporator. Horizontal plate seed metering (4 row).
2. John Deere MaxEmerge II - Trash whipper disks in front. Double disk furrow opener. Two angled wheels to control depth and close the furrow. Vacuum horizontal plate seed metering (8 row).
3. KSU Lister Furrower Planter - Small Moldboard furrower in front

- of a ACRA-Plant "V" shoe seed furrow opener followed by 2 angled covering wheels. IH air pressure seed metering (4 row).
4. KSU Disk Furrower Planter - ACRA-Plant disk furrower in front of a "V" shoe seed furrow opener followed by 2 angled covering wheels. IH air pressure seed metering (4 row).
 5. Hoe Opener with a Pacific Alloy Castings "C-14" Tip. "V" Type Press wheel.
 6. Hoe Opener with a Pacific Alloy Castings "C-14" Tip. Inverted "V" Type Press wheel.
 7. Hoe Opener with an ACRA-Plant "Z-6" Tip. "V" Type Press Wheel.
 8. Hoe Opener with an ACRA-Plant "Z-6" Tip. Inverted "V" Type Press Wheel.

All of the hoe-type treatments were variations of the KSU Hoe Drill. The downward force was held constant for all of the hoe drill type treatments at approximately 1217 N (274 lbs), which corresponds to a pressure of about 689 kPa in the accumulator (Appendix B).

Results

The average emergence for the different planters and tillage systems are shown in Tables 14 through 17. An analysis of variance procedure with alpha equal to 0.05 was used for this experiment (Appendix D). Separate analysis was performed on each crop. An attempt was also made to compare only treatments used under the same conditions. First, planters tested under both of the tillage treatments were analyzed. For this analysis planters numbered 2, 5, and 6 were deleted from the data set. The planter used proved to be a significant factor in determining

emergence for both crops, however different planters performed significantly better for each crop. When sunflowers were planted the Buffalo 4500 Till Planter, number 1, attained significantly higher emergence. For the sorghum the KSU Lister Furrower Planter achieved the highest emergence. This could be due to many things for example, the seed metering mechanism, seed size, or seed type.

For the next analysis the treatments which received an initial tillage for both crops were deleted from the data set which resulted in a comparison between all of the planters used in this experiment. This decision was based on the fact that the tillage treatment was not a significant factor in the previous analysis. As in the former analysis the planter used was also a significant factor with this data set. The results were basically unchanged for both crops, with the addition of the John Deere MaxEmerge II along with the KSU Lister Furrower Planter performing significantly better than the other planters when sorghum was seeded.

Table 14. Three Meter test row counts. Tillage = One pass at 5.1 cm with an offset disk harrow.**

Pltr*	Average Emergence (plants/row)		Number of Observations	
	Row1	Row2	Row1	Row2
1	8.3	9.0	3	3
2	NP	NP	0	0
3	16.0	11.0	3	3
4	0.0	0.0	3	3
5	NP	NP	0	0
6	NP	NP	0	0
7	3.0	1.0	3	3
8	3.3	7.7	3	3

- * 1. Buffalo 4500 Till Planter.
 2. John Deere MaxEmerge II.
 3. KSU Lister Furrower Planter.
 4. KSU Disk Furrower Planter.
 5. "C-14" hoe opener, "V" type press wheel.
 6. "C-14" hoe opener, inverted "V" type press wheel.
 7. "Z-6" hoe opener, "V" type press wheel.
 8. "Z-6" hoe opener, inverted "V" type press wheel.

** Scandia Irrigation Experiment Field July 16, 1987

** Sorghum

** NP (no plot was planted for this planter x tillage combination.)

Table 15. Three Meter test row counts. Tillage = None.**

Pltr*	Average Emergence (plants/row)		Number of Observations	
	Row1	Row2	Row1	Row2
1	11.3	12.0	3	3
2	17.7	16.7	3	3
3	14.7	15.7	3	3
4	0.7	0.0	3	3
5	5.0	3.5	3	3
6	3.0	4.5	3	3
7	2.3	6.3	3	3
8	7.3	2.0	3	3

- * 1. Buffalo 4500 Till Planter.
 2. John Deere MaxEmerge II.
 3. KSU Lister Furrower Planter.
 4. KSU Disk Furrower Planter.
 5. "C-14" hoe opener, "V" type press wheel.
 6. "C-14" hoe opener, inverted "V" type press wheel.
 7. "Z-6" hoe opener, "V" type press wheel.
 8. "Z-6" hoe opener, inverted "V" type press wheel.

** Scandia Irrigation Experiment Field July 16, 1987

** Sorghum

Table 16. Three Meter test row counts. Tillage = One pass at 5.1 cm with an offset disk harrow.**

Pltr*	Average Emergence (plants/row)		Number of Observations	
	Row1	Row2	Row1	Row2
1	5.0	6.3	3	3
2	NP	NP	0	0
3	0.0	1.3	3	3
4	2.3	1.7	3	3
5	NP	NP	0	0
6	NP	NP	0	0
7	0.3	2.3	3	3
8	0.7	2.3	3	3

- * 1. Buffalo 4500 Till Planter.
 2. John Deere MaxEmerge II.
 3. KSU Lister Furrower Planter.
 4. KSU Disk Furrower Planter.
 5. "C-14" hoe opener, "V" type press wheel.
 6. "C-14" hoe opener, inverted "V" type press wheel.
 7. "Z-6" hoe opener, "V" type press wheel.
 8. "Z-6" hoe opener, inverted "V" type press wheel.

** Scandia Irrigation Experiment Field July 16, 1987

** Sunflowers

** NP (no plot was planted for this planter x tillage combination.)

Table 17. Three Meter test row counts. Tillage = None.**

Pltr*	Average Emergence (plants/row)		Number of Observations	
	Row1	Row2	Row1	Row2
1	6.0	9.7	3	3
2	4.0	2.3	3	3
3	1.7	4.3	3	3
4	1.0	2.0	3	3
5	1.0	0.0	3	3
6	2.3	2.3	3	3
7	2.0	1.0	3	3
8	0.7	3.7	3	3

* 1. Buffalo 4500 Till Planter.
 2. John Deere MaxEmerge II.
 3. KSU Lister Furrower Planter.
 4. KSU Disk Furrower Planter.
 5. "C-14" hoe opener, "v" type press wheel.
 6. "C-14" hoe opener, inverted "v" type press wheel.
 7. "Z-6" hoe opener, "v" type press wheel.
 8. "Z-6" hoe opener, inverted "v" type press wheel.

** Scandia Irrigation Experiment Field July 16, 1987
 ** Sunflowers

Many of the planters had difficulty with the residue. These problems were amplified in the plots which received preplant tillage. The wheat straw was wet and very tough. From observing the different planters it was evident that performance may have been better under less severe conditions with respect to moisture.

Garden City Experiment

Four different configurations of the KSU Hoe Drill were evaluated in western Kansas at the Garden City Agricultural Experiment Station on an Ulysses silt loam. All of the treatments were evaluated in terms of seedling emergence and their ability to maintain a constant seeding depth using wheat. An analysis was done using SAS version 5.16 to evaluate the effect each treatment and the variables within them in determining emergence.

Procedure

For this experiment the KSU Hoe Drill was configured to seed four 25.4 cm rows. The experiment was laid out in a field which had received a number of passes with an undercutter and disk (Figure 25). The experimental design was a randomized complete block designed with four replications. Treatments were assigned at random within each replication. The treatments consisted of a combination of two press wheels, two downward forces, and two seeding depths. The following is a list of the eight different treatment identification numbers and their corresponding definitions:

1. Hoe opener with an ACRA-Plant "Z-6" tip, "V" type press wheel, 1357 N (305 lbs) of downward force, 3.8 cm seeding depth.
2. Hoe opener with an ACRA-Plant "Z-6" tip, "V" type press wheel, 1008 N (227 lbs) of downward force, 3.8 cm seeding depth.
3. Hoe opener with an ACRA-Plant "Z-6" tip, "V" type press wheel, 1357 N (305 lbs) of downward force, 6.4 cm seeding depth.
4. Hoe opener with an ACRA-Plant "Z-6" tip, "V" type press wheel,

- 1008 N (227 lbs) of downward force, 6.4 cm seeding depth.
5. Hoe opener with an ACRA-Plant "Z-6" tip, inverted "V" type press wheel, 1357 N (305 lbs) of downward force, 3.8 cm seeding depth.
 6. Hoe opener with an ACRA-Plant "Z-6" tip, inverted "V" type press wheel, 1008 N (227 lbs) of downward force, 3.8 cm seeding depth.
 7. Hoe opener with an ACRA-Plant "Z-6" tip, inverted "V" type press wheel, 1357 N (305 lbs) of downward force, 6.4 cm seeding depth.
 8. Hoe opener with an ACRA-Plant "Z-6" tip, inverted "V" type press wheel, 1008 N (227 lbs) of downward force, 6.4 cm seeding depth.

All the treatments were variations of the KSU Hoe Drill. The downward forces of 1008 N (227 lbs) and 1357 N (305 lbs) correspond to accumulator pressures of 482 and 827 kPa respectively (Appendix B). Seeding took place on October 8, 1987. The soil was very dry and loose at the time of seeding. Moisture was found at a depth of about 12.7 cm. Dodge Wheat was used and the seeding rate was approximately 6.7×10^5 seeds per hectare. At 90% emergence the expected plant population would be 5.9×10^5 . Seeding rates were checked by catching seeds from the two rows that were later used to evaluate emergence. Calibration was easier for the higher seeding rates than it was for the lower seeding rates used in earlier experiments however variation was still a problem.

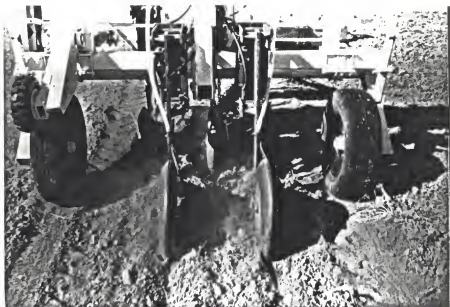

Figure 25. Test Plot at the Garden City Branch
Agricultural Experiment Station.

A 3 meter test row was counted for each treatment in each replication. These test rows are referred to as the leading and back row to correspond to their position on the test frame. At 90% germination one would expect each test row to have a maximum of about 120 plants. Also five plants were removed from each 3 meter test row and the seed depth was measured.

Results

On October 18, 1987 seedling emergence and seed depth were evaluated. No further evaluation was performed because it was felt that soil moisture was the limiting factor. Soil samples were not taken due to the large amount of fine loose topsoil. The average emergence for the different treatments is shown in Tables 18 and 19. Analysis of variance was performed at the significance level of alpha equal to 0.05 to test the effect that the different treatments had on emergence and seed

depth (Appendix E). First the treatments effect on emergence was evaluated. The treatment used and the variables within the treatments did not prove to be significant in determining emergence. Then the averages with respect to the position of the seeding unit on the frame were compared. The position of the seeding unit proved to be an important factor in determining seedling emergence. This may be due to the fact that some seeds were covered by an excessive amount of soil due to the soil flow and condition.

Table 18. Leading Row's Average Emergence. **

Trt*	Average Emergence (plants/row)	Number of Observations
1	28.50	4
2	31.50	4
3	32.00	4
4	48.00	4
5	28.25	4
6	25.00	4
7	16.75	4
8	17.00	4

- * 1. "V" type press wheel, 1357 N (305 lbs) of downward force, 3.8 cm seeding depth.
 2. "V" type press wheel, 1008 N (227 lbs) of downward force, 3.8 cm seeding depth.
 3. "V" type press wheel, 1357 N (305 lbs) of downward force, 6.4 cm seeding depth.
 4. "V" type press wheel, 1008 N (227 lbs) of downward force, 6.4 cm seeding depth.
 5. Inverted "V" type press wheel, 1357 N (305 lbs) of downward force, 3.8 cm seeding depth.
 6. Inverted "V" type press wheel, 1008 N (227 lbs) of downward force, 3.8 cm seeding depth.
 7. Inverted "V" type press wheel, 1357 N (305 lbs) of downward force, 6.4 cm seeding depth.
 8. Inverted "V" type press wheel, 1008 N (227 lbs) of downward force, 6.4 cm seeding depth.
 All treatments used an ACRA-Plant "Z-6" hoe opener.

** Garden City Agricultural Experiment Station 10/18/87

** Wheat

Table 19. Back Row's Average Emergence. **

Trt*	Average Emergence (plants/row)	Number of Observations
1	67.00	4
2	45.25	4
3	56.75	4
4	49.75	4
5	45.00	4
6	28.00	4
7	40.25	4
8	46.00	4

* 1. "V" type press wheel, 1357 N (305 lbs) of downward force, 3.8 cm seeding depth.
 2. "V" type press wheel, 1008 N (227 lbs) of downward force, 3.8 cm seeding depth.
 3. "V" type press wheel, 1357 N (305 lbs) of downward force, 6.4 cm seeding depth.
 4. "V" type press wheel, 1008 N (227 lbs) of downward force, 6.4 cm seeding depth.
 5. Inverted "v" type press wheel, 1357 N (305 lbs) of downward force, 3.8 cm seeding depth.
 6. Inverted "v" type press wheel, 1008 N (227 lbs) of downward force, 3.8 cm seeding depth.
 7. Inverted "v" type press wheel, 1357 N (305 lbs) of downward force, 6.4 cm seeding depth.
 8. Inverted "v" type press wheel, 1008 N (227 lbs) of downward force, 6.4 cm seeding depth.
 All treatments used an ACRA-Plant "Z-6" hoe opener.

** Garden City Agricultural Experiment Station 10/18/87
 ** Wheat

A similar analysis was performed to determine which factors effected the depth of seed placement. The average seed depths for each treatment are shown in Tables 20 and 21. When the results were averaged across the seeding unit positions and the treatment effects were compared, the press wheel, downward force, seeding depth, and the interaction between the press wheel and seeding depth was significant factors in determining the seed depth. This would indicate that factors

which effect soil flow and displacement have a significant effect on seed depth.

An analysis was also performed on the seed depth averages with respect to seeding unit position. Position was the only factor of significance in this analysis. This difference could be due to the amount of soil displaced by the back seeding unit due to soil condition and row spacing.

Table 20. Leading Row's Average Seeding Depth. **

Trt*	Average Depth (cm)	Number of Observations
1	11.55	20
2	9.60	10
3	10.90	10
4	9.60	10
5	9.20	15
6	7.70	10
7	11.90	10
8	9.64	11

* 1. "V" type press wheel, 1357 N (305 lbs) of downward force, 3.8 cm seeding depth.
 2. "V" type press wheel, 1008 N (227 lbs) of downward force, 3.8 cm seeding depth.
 3. "V" type press wheel, 1357 N (305 lbs) of downward force, 6.4 cm seeding depth.
 4. "V" type press wheel, 1008 N (227 lbs) of downward force, 6.4 cm seeding depth.
 5. Inverted "V" type press wheel, 1357 N (305 lbs) of downward force, 3.8 cm seeding depth.
 6. Inverted "V" type press wheel, 1008 N (227 lbs) of downward force, 3.8 cm seeding depth.
 7. Inverted "V" type press wheel, 1357 N (305 lbs) of downward force, 6.4 cm seeding depth.
 8. Inverted "V" type press wheel, 1008 N (227 lbs) of downward force, 6.4 cm seeding depth.
 All treatments used an ACRA-Plant "Z-6" hoe opener.

** Garden City Agricultural Experiment Station 10/18/87
 ** Wheat

Table 21. Back Row's Average Seeding Depth. **

<u>Trt*</u>	<u>Average Depth (cm)</u>	<u>Number of Observations</u>
1	7.95	20
2	7.60	10
3	9.18	17
4	9.00	10
5	6.80	15
6	7.80	10
7	10.27	15
8	8.73	15

* 1. "V" type press wheel, 1357 N (305 lbs) of downward force, 3.8 cm seeding depth.
2. "V" type press wheel, 1008 N (227 lbs) of downward force, 3.8 cm seeding depth.
3. "V" type press wheel, 1357 N (305 lbs) of downward force, 6.4 cm seeding depth.
4. "V" type press wheel, 1008 N (227 lbs) of downward force, 6.4 cm seeding depth.
5. Inverted "V" type press wheel, 1357 N (305 lbs) of downward force, 3.8 cm seeding depth.
6. Inverted "V" type press wheel, 1008 N (227 lbs) of downward force, 3.8 cm seeding depth.
7. Inverted "V" type press wheel, 1357 N (305 lbs) of downward force, 6.4 cm seeding depth.
8. Inverted "V" type press wheel, 1008 N (227 lbs) of downward force, 6.4 cm seeding depth.
All treatments used an ACRA-Plant "Z-6" hoe opener.

** Garden City Agricultural Experiment Station 10/18/87
** Wheat

In general, the condition of the soil and the moisture content made the task of producing an acceptable stand very challenging. This area had not received rain during the month of the experiment or the preceding month. It was difficult to place the seed at the level of adequate moisture and not cover the seed with an excess of soil.

Fort Hays Experiment

This experiment was performed at the Fort Hays Agricultural Experiment Station on a Harney silt loam. The treatments used, crop seeded, and the experiment design and analysis were the same as those used for the previous experiment at Garden City, Kansas. The major differences between these two sites were the amount and type of tillage operations performed prior to seeding, available soil moisture, and the amount of residue present.

The same statistical package and procedures used to analyze the results from the Garden City experiment were used for this experiment. However, the results obtained in terms of emergence and the significance of the treatment factors are more pronounced. This could be due to the firmness of the soil, the amount of moisture available, or the combination of these two factors.

Procedure

For this experiment the KSU Hoe Drill was configured the same as it was for the Garden City experiment, that is to seed four 25.4 cm rows. The experiment was laid out in a field which had received two passes with an undercutter and had some surface residue (Figure 26). The experimental design was a randomized complete block designed with four replications as in the prior experiment. Seeding took place on October 8, 1987. The topsoil was loose aggregate to a depth of approximately 7.6 centimeters where moisture was found. Dodge Wheat was used and the seeding rate was approximately 6.7×10^5 seeds per hectare, the same as that used on the previous site at Garden City. At

90% emergence a plant population of 5.9×10^5 would be expected.

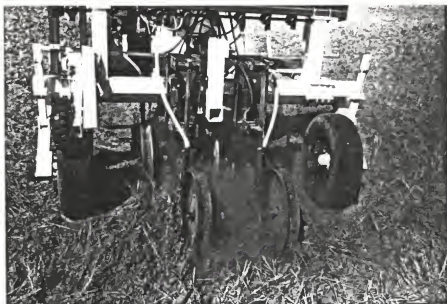

Figure 26. Test Plot at the Fort Hays Branch
Agricultural Experiment Station.

A 3 meter test row was counted for each treatment in each replication for each opener position. These test rows are referred to as the leading and back row to correspond to their position on the test frame. At 90% germination one would expect each 3 meter count row to have a maximum of about 120 plants. Also five plants were dug up from each test row and the seed depth was measured. The treatment identification numbers and definitions can be found on pages 53 and 54. The same approximate downward forces used at Garden City of 1008 N (227 lbs) and 1357 N (305 lbs) were used (Appendix B).

Results

On October 18, 1987 and October 30, 1987 seedling emergence and seeding depth were evaluated. Two evaluations were made at this location because it was observed that many seedlings had germinated but

had not yet emerged. Also the fact that it had not rained during this time and temperatures had fallen would account for the delay in emergence. No soil samples were taken to evaluate soil moisture because of the depth of loose soil. The average emergence for the different treatments is shown in Tables 22 and 23. When the row counts for the different treatments were averaged, that is both the leading and back row together, none of the treatments or variables within the treatments were significant factors in determining seedling emergence. However, when the averages were split according to unit position and analyzed the position was an important factor in determining stand. This suggests that the flow of soil between the seeding units has an effect on seeding success. This did not appear to be as serious a problem in this soil condition as is did in looser soil. Appendix F contains the analysis of variance table.

Table 22. Leading Row's Average Emergence. **

<u>Trt*</u>	<u>Average Emergence (plants/row)</u>	<u>Number of Observations</u>
1	21.00	4
2	26.50	4
3	27.50	4
4	7.25	4
5	40.00	4
6	27.75	4
7	41.25	4
8	38.00	4

- * 1. "V" type press wheel, 1357 N (305 lbs) of downward force, 3.8 cm seeding depth.
 2. "V" type press wheel, 1008 N (227 lbs) of downward force, 3.8 cm seeding depth.
 3. "V" type press wheel, 1357 N (305 lbs) of downward force, 6.4 cm seeding depth.
 4. "V" type press wheel, 1008 N (227 lbs) of downward force, 6.4 cm seeding depth.
 5. Inverted "v" type press wheel, 1357 N (305 lbs) of downward force, 3.8 cm seeding depth.
 6. Inverted "v" type press wheel, 1008 N (227 lbs) of downward force, 3.8 cm seeding depth.
 7. Inverted "v" type press wheel, 1357 N (305 lbs) of downward force, 6.4 cm seeding depth.
 8. Inverted "v" type press wheel, 1008 N (227 lbs) of downward force, 6.4 cm seeding depth.
 All treatments used an ACRA-Plant "Z-6" hoe opener.

** Fort Hays Agricultural Experiment Station 10/18/87

** Wheat

Table 23. Back Row's Average Emergence. **

Trt*	Average Emergence (plants/row)	Number of Observations
1	63.25	4
2	86.00	4
3	76.25	4
4	34.75	4
5	74.00	4
6	70.25	4
7	59.75	4
8	64.50	4

* 1. "v" type press wheel, 1357 N (305 lbs) of downward force, 3.8 cm seeding depth.
 2. "v" type press wheel, 1008 N (227 lbs) of downward force, 3.8 cm seeding depth.
 3. "v" type press wheel, 1357 N (305 lbs) of downward force, 6.4 cm seeding depth.
 4. "v" type press wheel, 1008 N (227 lbs) of downward force, 6.4 cm seeding depth.
 5. Inverted "v" type press wheel, 1357 N (305 lbs) of downward force, 3.8 cm seeding depth.
 6. Inverted "v" type press wheel, 1008 N (227 lbs) of downward force, 3.8 cm seeding depth.
 7. Inverted "v" type press wheel, 1357 N (305 lbs) of downward force, 6.4 cm seeding depth.
 8. Inverted "v" type press wheel, 1008 N (227 lbs) of downward force, 6.4 cm seeding depth.
 All treatments used an ACRA-Plant "Z-6" hoe opener.

** Fort Hays Agricultural Experiment Station 10/18/87
 ** Wheat

Seeding depth was evaluated in the same manner as the emergence. The average seed depths for each position are presented in Tables 24 and 25. When the result were averaged across the seeding unit position, the downward force and seeding depth were significant factors in determining seed depth, but when the seed depths were separated by position no single factor or combination influenced seed depth.

Table 24. Leading Row's Average Seeding Depth. **

Trt*	Average Depth (cm)	Number of Observations
1	5.27	15
2	5.05	20
3	9.75	20
4	10.00	5
5	6.55	20
6	5.53	15
7	9.20	15
8	7.47	15

* 1. "V" type press wheel, 1357 N (305 lbs) of downward force, 3.8 cm seeding depth.
 2. "V" type press wheel, 1008 N (227 lbs) of downward force, 3.8 cm seeding depth.
 3. "V" type press wheel, 1357 N (305 lbs) of downward force, 6.4 cm seeding depth.
 4. "V" type press wheel, 1008 N (227 lbs) of downward force, 6.4 cm seeding depth.
 5. Inverted "V" type press wheel, 1357 N (305 lbs) of downward force, 3.8 cm seeding depth.
 6. Inverted "V" type press wheel, 1008 N (227 lbs) of downward force, 3.8 cm seeding depth.
 7. Inverted "V" type press wheel, 1357 N (305 lbs) of downward force, 6.4 cm seeding depth.
 8. Inverted "V" type press wheel, 1008 N (227 lbs) of downward force, 6.4 cm seeding depth.
 All treatments used an ACRA-Plant "Z-6" hoe opener.

** Fort Hays Agricultural Experiment Station 10/18/87
 ** Wheat

Table 25. Back Row's Average Seeding Depth. **

<u>Trt*</u>	<u>Average Depth (cm)</u>	<u>Number of Observations</u>
1	6.00	20
2	4.95	20
3	8.90	20
4	6.90	20
5	6.20	20
6	5.45	20
7	8.30	20
8	7.20	20

* 1. "V" type press wheel, 1357 N (305 lbs) of downward force, 3.8 cm seeding depth.
 2. "V" type press wheel, 1008 N (227 lbs) of downward force, 3.8 cm seeding depth.
 3. "V" type press wheel, 1357 N (305 lbs) of downward force, 6.4 cm seeding depth.
 4. "V" type press wheel, 1008 N (227 lbs) of downward force, 6.4 cm seeding depth.
 5. Inverted "V" type press wheel, 1357 N (305 lbs) of downward force, 3.8 cm seeding depth.
 6. Inverted "V" type press wheel, 1008 N (227 lbs) of downward force, 3.8 cm seeding depth.
 7. Inverted "V" type press wheel, 1357 N (305 lbs) of downward force, 6.4 cm seeding depth.
 8. Inverted "V" type press wheel, 1008 N (227 lbs) of downward force, 6.4 cm seeding depth.
 All treatments used an ACRA-Plant "Z-6" hoe opener.

** Fort Hays Agricultural Experiment Station 10/18/87
 ** Wheat

The conditions at this location were a good test of the ability of this hoe drill prototype. The topsoil was some what loose to a depth of about 7.6 centimeters, however the soil beneath that was firm. The soil moisture was not overly abundant, but it was not felt to be a limiting factor. Also the conditions with respect to surface residue were challenging, but not a limiting factor.

DISCUSSION OF RESULTS

Five different experiments were run to evaluate the performance of the KSU Hoe Drill. The first study was a preliminary evaluation of four furrow opener tips and tips in combination with two press wheels. This investigation took place in a soil bin filled with an artificial soil. All combinations were compared on a qualitative basis in terms of soil displacement and the tip press wheel combination was also compared in terms of "seeding depth". The results were: A direct relationship between operation depth and soil displacement. A relationship between the press wheel used and soil displaced. The "V" type press wheel appeared to displace more soil, which matched the physical features of the furrow resulting from its use, and allowed deeper penetration. All of the tip press wheel combinations seem to be able to maintain a consistent depth of soil over the seed zone with varying tip depth.

Next a four row prototype was used to seed forage sorghum on June 16, 1988 at the Colby Branch Agricultural Experiment Station. Moisture was plentiful and the conventionally tilled Kieth silt loam soil was firm at planting. Also an initial irrigation was applied to alternate halves of each replication to test the effect of crusting. Two types of planters were used, a double disk opener and a hoe drill which were varied in terms of seeding depth. Also the hoe drill used four combinations of furrow opener tips and press wheels. The effect of these treatment variations on emergence were evaluated statistically. The level of irrigation, furrow opener, and the seeding depth all had a significant effect on emergence. Upon closer investigation it was determined that the treatments which used a hoe-type furrow opener at a seeding depth

of 2.5 cm attained higher emergence levels than those which received no initial irrigation. Based on the amount and frequency of rainfall received at this location the effect of the initial irrigation was probably not due to surface crusting. The reduced emergence could have been due to the higher cumulative level of soil moisture which may have caused decreased infiltration and therefore increased runoff and erosion. This increased erosion had the effect of covering the germinated seeds which had not fully emerged.

Late in June of 1987 sorghum and sunflower test plots were planted at the Scandia Irrigation Agricultural Experiment Field. Two tillage levels were applied to the Crete silt loam which had approximately 11,000 kg per hectare of wheat residue. The tillage treatments were a single pass with an offset disk harrow at 5.1 cm and no preplant tillage. Five types of drills were evaluated at this location. All of the seeding was done at a depth of 2.5 cm. The drill used proved to be the only significant factor in determining emergence. When the emergence averages were compared, the Buffalo 4500 Till Planter provided the best stand in the sunflower plots. In the sorghum plots 2 drills performed significantly better than the rest. They were the KSU Lister Furrower Planter and the John Deere MaxEmerge II. The John Deere MaxEmerge II was not used under the tilled conditions. Overall the level of emergence achieved was low. This could have been due to the amount and condition of the surface residue or the high moisture level of the soil.

The last two evaluations were identical with respect to the KSU Hoe Drill treatments used which were combinations of two press wheels, two downward forces, and two seeding depths. The Garden City Agricultural

Experiment Station's Ulysses silt loam had been tilled several times with a disk harrow and an undercutter. Fort Hays Agricultural Experiment Station's Harney silt loam had received only two tillage passes with an undercutter. Neither site had received rainfall in the months preceding and the month of the evaluation however, there appeared to be less available moisture at the Garden City location. When the results were analyzed the effect of the position of seeding unit on the frame was also considered. At both locations the position was a significant factor in determining emergence. At Garden City, the interaction between the position and downward force along with the interaction between the press wheel, seeding depth, and position were also significant. The rear seeding unit achieved higher emergence than the leading unit. This is probably due to the amount of soil displaced by the rear opener along with the relatively narrow row spacing. The additional factors which were significant at Garden City could be related to soil flow, soil condition, the ability of the press wheel to control seeding depth, and the force by which the furrow opener penetrated the surface.

At both of these locations the ability to maintain a constant seeding depth was also evaluated. The intended seeding depth was a significant factor at both Garden City and Fort Hays. In addition to that the position of a seeding unit on the test frame was significant at Garden City and the amount of downward force used was significant at Fort Hays. This would suggest that KSU Hoe Drill along with soil condition played a role in determining the depth at which the seed was actually placed.

CONCLUSIONS

As expected the soil condition with respect to firmness, soil moisture, residue, the type and level of tillage along with the interaction between these factors played an important part in the ability of a seeding unit to establish a crop stand. Overall the ability to accurately place the seed at the depth of soil moisture without placing an excessive amount of soil over the seed along with good seed-to-soil contact proved to be the most important attributes a planter could have.

The KSU Hoe Drill has demonstrated the potential to solve many of the problems common to no-till seeders. At the Scandia Irrigation Agricultural Experiment Field and the Fort Hays Branch Agricultural Experiment Station it demonstrated the ability to operate in heavy and randomly orientated residue. Depth control was exhibited at both the Garden City and Fort Hays Branch Agricultural Experiment Stations. The ability of this prototype to adapt to varying soil conditions with respect to moisture and compaction was displayed at all the test sites. When the conditions at each site are considered the fact that acceptable stands were produced demonstrate its overall potential.

FUTURE RESEARCH

The results of this research warrant further investigation into no-till seeding. In general, the researcher should pay close attention to any possible sources of error. Proceeding in this manner allows the variables under consideration to be evaluated more accurately. The experimental design should be thought out thoroughly to avoid an evaluation with no significant results or statistical power.

When an evaluation of this type is performed, defining the components to be tested is very important. Those components which are not to be evaluated should be as consistent as possible with an experiment. For example, in this research different drill types with respect to their furrow opener press wheel combinations were evaluated in terms of their ability to produce an acceptable stand. Therefore, it would have been desirable to use seed metering devices with the same approximate capability in terms of accuracy. However, this is not always possible so careful attention should be given to minimize this source of error.

The KSU Hoe Drill could solve the problems associated with no-till seeding. Its ability to handle residue, penetrate the soil, and control seeding depth was encouraging. The concept of a variable downward force allows it to be used in a variety of soil conditions as did the reversible press wheel. Better performance may be attained by increasing the width of the press wheel and decreasing the distance between the center of the press wheel and the opener shank. This could be accomplished by modifying the dimensions of the press wheel mounting and shank. A less expensive means for controlling downward force also

needs to be investigated such as the use of an air bag type system.

REFERENCES

- Allen R. R., P. W. Unger and L. J. Fulton. 1984. Sorghum seeders in no-till wheat residue. Bushland, Texas. USDA-Agricultural Research Service Conservation and Production Research Laboratory. ASAE Paper No. 84-1512.
- Bolton, F. E. and D. E. Booster. 1979. Strip-till planting in dryland cereal production. Corvallis, Oregon. Oregon State University. ASAE Paper No. 79-1530.
- Boots, E. 1986. Personal communication. Garden City, Kansas.
- Borden, J. W. and M. C. Wittrock. 1987. Trends of equipment development for conservation tillage. Denver, Colorado. Eversman Manufacturing Company. ASAE Paper No. 87-1611.
- Fenster, G. A. and G. A. Wicks. 1976. Minimum tillage fallow systems for reducing wind erosion. Transactions of The ASAE. 20:906-909.
- Frederick, R. T., J. A. Hobbs and R. L. Donahue. 1980. Soil and water conservation for productivity and environmental protection. Prentice-Hall, Inc., Englewood Cliffs, New Jersey. pp 274-316.
- Griffith, D. R. and S. D. Parsons. 1983. Energy requirement for various tillage-planting systems. North Central Regional Extension Publication 202.
- Herron, M. M. 1978. Development of a reduced tillage planter for the semi-arid great plains region. Master's Thesis. Department of Agricultural Engineering. Kansas State University.
- Johnson, W. H. and J. E. Henry. 1964. Influence of simulated row compaction on seedling emergence and soil drying rates. Transactions of ASAE. 7:252-255.
- King, A. D. 1983. Obstacles to adoption of conservation tillage. Journal of Soil and Water Conservation. 38(3):162-165.
- Mannering, J. V. and C. R. Fenster. 1983. What is conservation tillage? Journal of Soil and Water Conservation. 38(3):141-143.
- Payton, D. M., G. M. Hyde and J. B. Simpson. 1979. Equipment and method for no till wheat planting. Pullman, Washington. Washington State University. ASAE Paper No. 79-1022.
- Peterson, C. L., E. A. Dowding and R. W. Harder. 1978. Chisel-planter: An experimental till-plant erosion control system for the Palouse. Moscow, Idaho. ASAE Paper No. 78-1015.

Peterson, C. L., E. A. Dowding and R. W. Harder. 1978. Chisel-planter, an experimental till-plant erosion control system for the Palouse. Moscow, Idaho. ASAE Paper No. 78-1015.

Pollard, L. R., M. J. Hanley and W. K. Krahenbuhl. 1986. Case IH 8500 air drill. Hinsdale, Illinois. JI Case Agricultural Equipment and Component Engineering Center. Presented at the ASAE 1986 Winter Meeting. Chicago, Illinois.

Rogers, R. B. and R. Baron. 1987. Cereal punch seeder; true zero till seeding. Saskatoon, Saskatchewan, Canada. Rogers Engineering Inc. ASAE Paper No. 87-1615.

Schrock, M. D., D. L. Oard and S. J. Clark. 1982. Seed placement and emergence of winter wheat planted with an air seeder. Manhattan, Kansas. Kansas State University. ASAE Paper No. MC82-137.

Suderman, D. A. 1981. Development of the Kansas State University mulch tillage planter. Master's Thesis. Agricultural Engineering Department, Kansas State University.

Townsend J. S. and J. M. Bethge. 1984. Furrow opener for proper seed and fertilizer placement in no-till. Winnipeg, Manitoba, Canada. University of Manitoba. ASAE Paper No. 84-1511.

U.S. Department of Agriculture. 1987. Highly erodible land and wetland conservation; Final rule and notice of finding of no significant impact. Federal Register. 52(180).

Wilkins, D. E., R. R. Allmaras, G. A. Muilenburg, and C. E. Johnson. 1981. Effect of grain drill opener on wheat emergence. USDA-SEA-AR, Western Region, Oregon State University, Auburn University. ASAE Paper No. 81-1021.

APPENDICES

Appendix A

Computer Program Used to Integrate the Area Under the Soil Displacement Curve.

Integration Method: Simpson's Rule

Programming Language: C

Programmer: Kent Funk

Main Program:

```
#include <stdio.h>
#include <math.h>

main()
{
    char line[80];
    int first;
    double yi, yi2, xi, xi2, sum, da, fabs();

    first = 1;
    sum = 0.0;
    while (fgets(line, 80, stdin)) {
        sscanf(line, "%f %f\n", &xi, &yi);
        if (!first) {
            da = (yi2+yi)/2.0 *fabs(xi-xi2);
            sum + = da;
            xi2 = xi;
            yi2 = yi;
        } else {
            xi2 = xi;
            yi2 = yi;
            first = 0;
        }
        printf("%f %f %f\n", xi, yi, sum);
    }
}
```

Appendix B

Opener Force Example Calculation

seeding unit dead weight = 52.21 kgs

cylinder diameter = 5.08 cm

cylinder stroke = 10.16 cm

$$\begin{aligned}\text{cylinder force} &= (\text{accumulator pressure}) * (\text{cylinder area}) \\ &= (\text{kPa}) * (\text{cm}^2) \\ &= \text{N} \\ &= (689 \text{ kPa}) * (\pi * (2.54 \text{ cm})^2) \\ &= 1396 \text{ N}\end{aligned}$$

$$\begin{aligned}\text{cylinder opener force} &= \frac{(\text{cylinder force})}{(\text{linkage moment arm}) / (\text{cylinder moment arm})} \\ &= \frac{1396 \text{ N}}{(27.94 \text{ cm}) / (13.97 \text{ cm})} \\ &= 698 \text{ N}\end{aligned}$$

$$\begin{aligned}\text{total opener force} &= (\text{cylinder opener force}) + (\text{opener dead weight}) \\ &= 698 \text{ N} + (52.91 \text{ kgs} * 9.81 \text{ m/s}^2) \\ &= 1217 \text{ N}\end{aligned}$$

Appendix C

Colby Experiment Analysis of Variance Table

Dependant Variable: Seedling Emergence		
<u>Source</u>	<u>Degrees of Freedom</u>	<u>Sum of Squares</u>
Replication (Rep)	2	21.23
Irrigation (Irr)	1	212.82 *
Rep*Irr	1	275.03
Furrow opener (Tip)	1	1285.15 **
Press wheel (PW)	1	52.08
Depth (Dep)	1	350.42 **
Irr*Tip	2	48.68
Irr*PW	1	33.33
Irr*Dep	1	6.02
Tip*PW	1	33.33
Tip*Dep	2	126.42
PW*Dep	1	16.33
Irr*Tip*PW	1	14.08
Irr*Tip*Dep	2	24.15
Irr*PW*Dep	1	14.08
Tip*PW*Dep	1	6.75
Irr*Tip*PW*Dep	1	27.00
Residual	36	1609.07
Corrected Total	59	4154.98

Dependant Variable: Uniformity Index		
<u>Source</u>	<u>Degrees of Freedom</u>	<u>Sum of Squares</u>
Replication (Rep)	2	1.35
Irrigation (Irr)	1	0.42
Rep*Irr	1	1.96 *
Furrow opener (Tip)	1	0.00
Press wheel (PW)	1	0.07
Depth (Dep)	1	0.03
Irr*Tip	2	0.06
Irr*PW	1	0.00
Irr*Dep	1	0.00
Tip*PW	1	0.27
Tip*Dep	2	0.34
PW*Dep	1	0.32
Irr*Tip*PW	1	0.06
Irr*Tip*Dep	2	0.10
Irr*PW*Dep	1	0.52

Tip*PW*Dep	1	0.38
Irr*Tip*PW*Dep	1	0.00
Residual	36	10.29
Corrected Total	59	16.18

* F-Statistic Significant at alpha = 0.05

** F-Statistic Significant at alpha = 0.01

Appendix D

Scandia Experiment Analysis of Variance Table

Dependant Variable: Sorghum Seedling Emergence.
 Tested: Planters used with both levels of tillage.

<u>Source</u>	<u>Degrees of Freedom</u>	<u>Sum of Squares</u>
Replication	2	17.27
Planter	4	768.00 **
Tillage	1	12.68
Planter*Tillage	4	14.37
Residual	18	65.73
Corrected Total	29	878.04

Dependant Variable: Sorghum Seedling Emergence.
 Tested: Planters used with no preplant tillage.

<u>Source</u>	<u>Degrees of Freedom</u>	<u>Sum of Squares</u>
Replication	2	10.75
Planter	4	788.24 **
Residual	14	51.42
Corrected Total	23	850.41

Dependant Variable: Sunflower Seedling Emergence.
 Tested: Planters used with both levels of tillage.

<u>Source</u>	<u>Degrees of Freedom</u>	<u>Sum of Squares</u>
Replication	2	4.62
Planter	4	122.72 **
Tillage	1	7.01
Planter*Tillage	4	9.28
Residual	18	31.22
Corrected Total	29	174.84

Dependant Variable: Sunflower Seedling Emergence.
 Tested: Planters used with no preplant tillage.

<u>Source</u>	<u>Degrees of Freedom</u>	<u>Sum of Squares</u>
Replication	2	15.25 *
Planter	4	104.33 **
Residual	14	22.92

Corrected Total	23	142.50
-----------------	----	--------

* F-Statistic Significant at alpha = 0.05
** F-Statistic Significant at alpha = 0.01

Appendix E

Garden City Experiment Analysis of Variance Table

Dependant Variable: Seedling Emergence
Degrees of

<u>Source</u>	<u>Freedom</u>	<u>Sum of Squares</u>
Replication (Rep)	3	37316.25
Press wheel (PW)	1	3164.06
Pressure (Pres)	1	144.00
Depth (Dep)	1	16.00
PW*Pres	1	5.06
PW*Dep	1	105.06
Pres*Dep	1	729.00
PW*Pres*Dep	1	0.56
Error ^a	21	31202.75
Position (Pos)	1	5700.25 **
PW*Pos	1	10.56
Pres*Pos	1	784.00 *
Dep*Pos	1	12.25
PW*Pres*Pos	1	390.06
PW*Dep*Pos	1	855.56 *
Pres*Dep*Pos	1	110.25
PW*Pres*Dep*Pos	1	76.56
Residual	24	3985.50
Corrected Total	63	84607.75

Dependant Variable: Seed Depth
Degrees of

<u>Source</u>	<u>Freedom</u>	<u>Sum of Squares</u>
Replication (Rep)	3	3.42
Press wheel (PW)	1	4.66
Pressure (Pres)	1	9.43
Depth (Dep)	1	16.49
PW*Pres	1	0.13
PW*Dep	1	9.51
Pres*Dep	1	0.59
PW*Pres*Dep	1	2.90
Error ^a	11	18.05
Position (Pos)	1	36.81 **
PW*Pos	1	1.97
Pres*Pos	1	5.23
Dep*Pos	1	0.76
PW*Pres*Pos	1	0.24
PW*Dep*Pos	1	1.67
Pres*Dep*Pos	1	1.12
PW*Pres*Dep*Pos	1	1.17

Residual	24	3985.50
Corrected Total	63	84607.75

Tested: Main effects on seed depth using error^a

Press wheel (PW)	1	2.88
Pressure (Pres)	1	8.95
Depth (Dep)	1	20.54 **
PW*Pres	1	0.40
PW*Dep	1	7.37
Pres*Dep	1	0.55
PW*Pres*Dep	1	0.85

* F-Statistic Significant at alpha = 0.05

** F-Statistic Significant at alpha = 0.01

a This is the whole plot error used in forming the F-statistic for the main effects and interactions.

Appendix F

Fort Hays Experiment Analysis of Variance Table

Dependant Variable: Seedling Emergence
Degrees of

<u>Source</u>	<u>Freedom</u>	<u>Sum of Squares</u>
Replication (Rep)	3	7187.50
Press wheel (PW)	1	1332.25
Pressure (Pres)	1	576.00
Depth (Dep)	1	885.06
PW*Pres	1	90.25
PW*Dep	1	451.56
Pres*Dep	1	1314.06
PW*Pres*Dep	1	2889.06
Error ^a	21	17655.25
Position (Pos)	1	22425.06 **
PW*Pos	1	798.06
Pres*Pos	1	39.06
Dep*Pos	1	812.25
PW*Pres*Pos	1	105.06
PW*Dep*Pos	1	9.00
Pres*Dep*Pos	1	380.25
PW*Pres*Dep*Pos	1	361.00
Residual	24	5468.25
Corrected Total	63	62779.00

Dependant Variable: Seed Depth
Degrees of

<u>Source</u>	<u>Freedom</u>	<u>Sum of Squares</u>
Replication (Rep)	3	24.30
Press wheel (PW)	1	0.03
Pressure (Pres)	1	29.34
Depth (Dep)	1	88.14
PW*Pres	1	0.26
PW*Dep	1	2.89
Pres*Dep	1	2.23
PW*Pres*Dep	1	0.46
Error ^a	21	22.77
Position (Pos)	1	1.62
PW*Pos	1	0.06
Pres*Pos	1	0.44
Dep*Pos	1	0.73
PW*Pres*Pos	1	0.26
PW*Dep*Pos	1	0.24
Pres*Dep*Pos	1	0.00
PW*Pres*Dep*Pos	1	0.07

Residual	17	12.89
Corrected Total	56	186.73

Tested: Main effects on seed depth using error^a

Press wheel (PW)	1	0.01
Pressure (Pres)	1	18.11 **
Depth (Dep)	1	64.00 **
PW*Pres	1	0.12
PW*Dep	1	1.77
Pres*Dep	1	1.10
PW*Pres*Dep	1	0.05

* F-Statistic Significant at alpha = 0.05

** F-Statistic Significant at alpha = 0.01

a This is the whole plot error used in forming the F-statistic for the main effects and interactions.

DEVELOPMENT OF A HOE DRILL DEPTH CONTROL
SYSTEM FOR THE GREAT PLAINS REGION

by

RICHARD P. HATLEN

B.S., University of Wisconsin-Madison, December, 1985

AN ABSTRACT OF A MASTER'S THESIS

submitted in partial fulfillment of the

requirements for the degree

MASTER OF SCIENCE

Department of Agricultural Engineering

KANSAS STATE UNIVERSITY
Manhattan, Kansas
1988

ABSTRACT

Research and development in the area of conservation tillage has increased in recent years, but the practice of seeding a crop through surface residue is not one that has been easily accepted. However, as the benefits become more evident and the equipment improves these barriers decrease. The desire to decrease the cost of production, the need to reduce soil erosion, and the pressure provided by the Food Security Act of 1985 have been instrumental in bringing about this change.

The objective of this research was to develop a planter which would solve some of the problems producers commonly have when using a conservation tillage system. Specifically, this seeder was designed to operate in varying soil conditions, heavy residue, and maintain a nearly constant seed depth over varying topography. This was accomplished by using a single wheel to control the depth of a hoe type furrow opener and firm the soil over the seed zone. A hydraulically controlled parallel arm linkage used to mount the units in 2 ranks and give it the ability to adapt to varying soil and topographic conditions. This arrangement was termed the KSU Hoe Drill.

Five evaluations were performed. The first was a qualitative analysis of the amount of soil displaced by each of 4 furrow openers and the furrow openers in combination with 2 press wheel configurations. It was felt that there would be an advantage to the combination which displaced the least amount of "soil". Also the ability of the furrow opener / press wheel combinations were evaluated in terms of maintaining a consistent "seeding depth".

The last 4 experiments were seeding trials at various locations

throughout Kansas. At Colby 4 configurations of the KSU Hoe Drill along with a John Deere double disk opener were studied at 2 seeding depths for their ability to seed grain sorghum. The Scandia investigation was a comparison study between 5 different types of planters for their ability to seed both sorghum and sunflowers under 2 levels of tillage. The last 2 experiments were at Garden City and Fort Hays, Kansas. Both evaluated the KSU Hoe Drill's ability to maintain a nearly constant seeding depth and produce an acceptable stand when seeding wheat. The treatments compared the effects that the downward force on the opener, seeding depth, and press wheel type had on the seeding unit's performance.

The results indicate that the planter used in most cases was a significant factor in determining emergence. However, the interaction between the planter and soil appeared to determine the success of a planter.