

**GASANOV M., PERMYAKOV A., KLOCHKO A., SHELKOVY A.**

### **NEW STRENGTH FOR RECOVERY OF GEARED CIRCLES**

**The subject matter** of the research is issues related to the optimization of the technology for reconditioning large-size high precision gear rims of the drives of mining complexes, mine lifting equipment, heavy vehicles; these issues are a perspective trend for reducing the cost of reconditioning and operation of expensive unique equipment. **The goal** is to ensure intensifying production processes, increasing workloads and speeds, reducing the deterioration of high precision gear rims. **The objective** is to develop a new technology to optimize reconditioning large high precision gear rims. To achieve this, the following **method is suggested** – to machine gear rims after they have been surfaced by pre-milling with special hob cutters with a prominence and by final machining the teeth with special cutters equipped with hardmetal inserts that process teeth along the line of engagement, which does not require making full-length cutting teeth and increases the quality of machining, the durability of hardmetal milling cutters. The following **results** are obtained. **Conclusions.** The technology for the optimization of reconditioning large high precision gear rims with the use of special and universal hardmetal single- and double-flute cutters that have both re-sharpened cutting elements and disposable rotary tools was developed and introduced.

**Keywords:** new optimization technology, reconditioning large gear rims, high precision, hob cutters with a protuberance, special cutters, machining tooth along the line of engagement, improving the quality of machining.

**ГАСАНОВ М.И., ПЕРМЯКОВ А.А., КЛОЧКО А.А., ШЕЛКОВОЙ А.Н.**  
**НОВАЯ СТРАТЕГИЯ ВОССТАНОВЛЕНИЯ ЗУБЧАТЫХ ВЕНЦОВ**

Предметом исследования являются вопросы, связанные с оптимизацией технологии восстановления крупногабаритных высокоточных зубчатых колес приводов горных комплексов, шахтного подъемного оборудования, тяжелых транспортных средств; Эти вопросы являются перспективной тенденцией снижения затрат на восстановление и эксплуатацию дорогостоящего уникального оборудования. Цель состоит в том, чтобы обеспечить интенсификацию производственных процессов, увеличение рабочих нагрузок и скоростей, снижение износа высокоточных зубчатых колес. Цель состоит в том, чтобы разработать новую технологию для оптимизации восстановления больших высокоточных зубчатых колес. Для достижения этой цели предлагается следующий метод - обрабатывать зубчатые колеса после их обработки путем предварительной фрезерования специальными фрезами с выпуклым выступом и окончательной обработки зубьев специальными фрезами, оснащенными твердосплавными пластинами, которые обрабатывают зубья по линии зацепления, которое не требует изготовления полноразмерных режущих зубьев и повышает качество обработки, долговечность твердосплавных фрез. Получены следующие результаты. Выводы. Была разработана и внедрена технология оптимизации восстановления больших высокоточных зубчатых колес с использованием специальных и универсальных твердосплавных одно- и двух-канавочных резцов, которые имеют как заточенные режущие элементы, так и одноразовые вращающиеся инструменты.

**Ключевые слова:** новая технология оптимизации, восстановление больших зубчатых колес, высокая точность, фрезы с выпуклостью, специальные фрезы, обработка зубьев по линии зацепления, повышение качества обработки.

**ГАСАНОВ М.І., ПЕРМЯКОВ О.А., КЛОЧКО О.О., ШЕЛКОВОЙ О.М.**  
**НОВА СТРАТЕГІЯ ВІДНОВЛЕННЯ ЗУБЧАСТИХ ВІНЦІВ**

Проводити дослідження, що стосуються питань, пов'язаних з оптимізацією технологій встановлення великих великобудівних високоточних зубчастих колесів, що приносять гірські комплекси, шахтного підключення обладнання, важких транспортних середніх; Эти питання пропонують перспективну тенденцію зменшення затрат на відновлення та експлуатацію дорогостоящего уникального обладнання. Це може бути реалізовано в тому, щоб забезпечити інтенсивну ефективність виробничих процесів, збільшення робочих навантажувачів і скоростей, зменшення виносності високих зубчастих колесів. Ціль міститься в тому, щоб розробити нову технологію для оптимізації встановлення найбільших високоточних зубчастих колесів. Для досягнення цього цілого пропонується наступний метод - образити зубчасті колеса після їх обробки путем передвірної фрезерування спеціальними фрезами з випускним выступом і кінцевою обробкою зубчими особливими фрезами, оснащеними твердими пластичними пластинами, які розробляються в лінійці, що потрібна обробки, долговечность твердосплавних фрез. Получені наступні результати. Виводи. Будучи розробленими та вбудованими технологічними оптимізаціями, відтворені великі високі високоточні зубчасті колеса із застосуванням спеціальних та універсальних твердосплавних одно- та двоканальних каналів, які мають як заточені нові елементи, так і одноразові вражаючі інструменти.

**Ключові слова:** нова технологічна оптимізація, відтворення великих зубчастих колесів, висока точність, фреза з випускництвом, спеціальні фрези, обробка зуб'єв за лініями вибірки, підвищення якості роботи

**1. Introduction.** The performance of mining complexes, mine lifting equipment, heavy vehicles is gradually getting worse due to the deterioration of their equipment in the process of operation. Among them, there are large high precision gear rims. Such large gears can have failures and malfunctions that are fixed in the course of various types of reconditioning and repairing activities. To ensure high-quality recovery, a new technology for the optimization of reconditioning large high precision gear rims is suggested.

The service life of fast-wearing large gear trains determines the prove-in performance of expensive machines. Stopping equipment to replace worn large gear trains with new ones leads to a significant decrease in labour productivity, disrupts the rhythm of the production process, causes non-productive metal costs to

manufacture new parts and results in the need for special maintenance teams.

**2. Analysis of literary sources and problem statement.** Modern trends in intensifying of production processes, increasing workloads, speeds, temperatures lead to faster deterioration of parts, and along with the need for production automation, give points to the problem of increasing the service life of quickly deteriorated machine parts [1, 4, 7, 9], so most of the parts that are connected with other parts wear out fast. This process results in material damage when the material scales off the solid surface and its friction strain accumulates. These phenomena lead to a gradual change in the size and shape of a part. The techniques for reconditioning the parts and joint connections are resource-saving, as compared to the manufacture of new

parts, the costs for materials in manufacturing are significantly reduced, a number of technological operations is decreased, the costs for machine tools, devices, cutting and measuring equipment as well as for labour remuneration of workers are reduced [2, 3, 5, 10]. A part that has toothed surfaces is known to be under cyclic and dynamic loads while operating, which leads to the damage of working surfaces. The smooth operation of the gear train can be ensured only at a constant gear ratio but due to manufacturing and operation errors, for example, the deformation of teeth, the gear ratio does not remain constant at every time [6, 8, 11]. Moreover, dynamic loads or interference generate an additional negative impact. The deformation of gear wheels, as well

as manufacturing errors lead to uneven distribution of the load across the width of the gear rim.

When the worn-out teeth are repaired by surfacing, the worn side of each tooth is surfaced when the gear wheels are of a large diameter (up to 15 m) and a module is of more than 10 mm. High wear resistance and durability of the faced surfaces of teeth can be ensured by using the alloys of sormite and stalinite types. A thin coat of sormite is spread on the surface firstly faced with a filler material and roughed up (Fig. 1). After surfacing with sormite, the teeth are firstly milled with special hob cutters with a prominence and finally machined with special cutters with hardmetal inserts [1, 2, 3].



Fig. 1 – Worn large gear wheels: a) a worn cylindrical gear wheel; б) a worn cylindrical gear wheel surfacing

When operating large cylindrical gear trains, the following types of tooth fracture occur: fatigue spalling of the teeth working surfaces, chipping of the teeth, deterioration, binding of teeth, crushing of the teeth working surfaces. Fatigue spalling of the teeth working surfaces which usually occurs near the operating pitch circle on a tooth root fillet is the main type of destruction of enclosed gears. The cause is variable contact pressures

on the surface of the teeth  $\sigma_H$ ; these stresses cause primary cracks, extending cracks, chipping, shelling, slivering of metal from the tooth surface (Fig. 2) [7]. A crack at the tooth root often causes chips which results in the increase in the contact pressure and the disruption in the tooth gearing [4, 5, 6, 7, 12]. Surface layers in open gears abrade before fatigue cracks appear in them, so spalling happens very rarely.

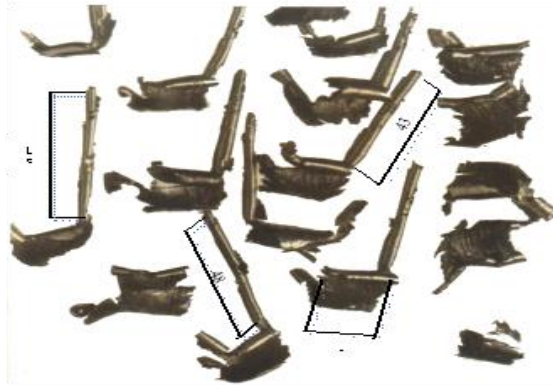

Fig. 2 – Chips cut by the finishing cutter ( $m=20$  mm) without teeth cutting by a cutter with a prominence

**3. The goal and objectives of the research** The goal and objectives of the research are to ensure intensifying production processes, increasing workloads, speeds, reducing the deterioration of high precision gear rims and developing a new technology to optimize the recovery of large high precision gear rims. To achieve this, a method for machining teeth after surfacing by pre-milling with special hob cutters with a protuberance and by final machining the teeth with special cutters equipped with

hardmetal inserts that machine teeth along the line of engagement, which does not require that cutting teeth of milling cutters be manufactured along the full length and which significantly improves the quality of machining, increases the durability of hardmetal milling cutters.

To carry out research, a structurally logical diagram of the process was developed to optimize the technology for restoring large-sized gear rims of increased accuracy (Fig. 3).

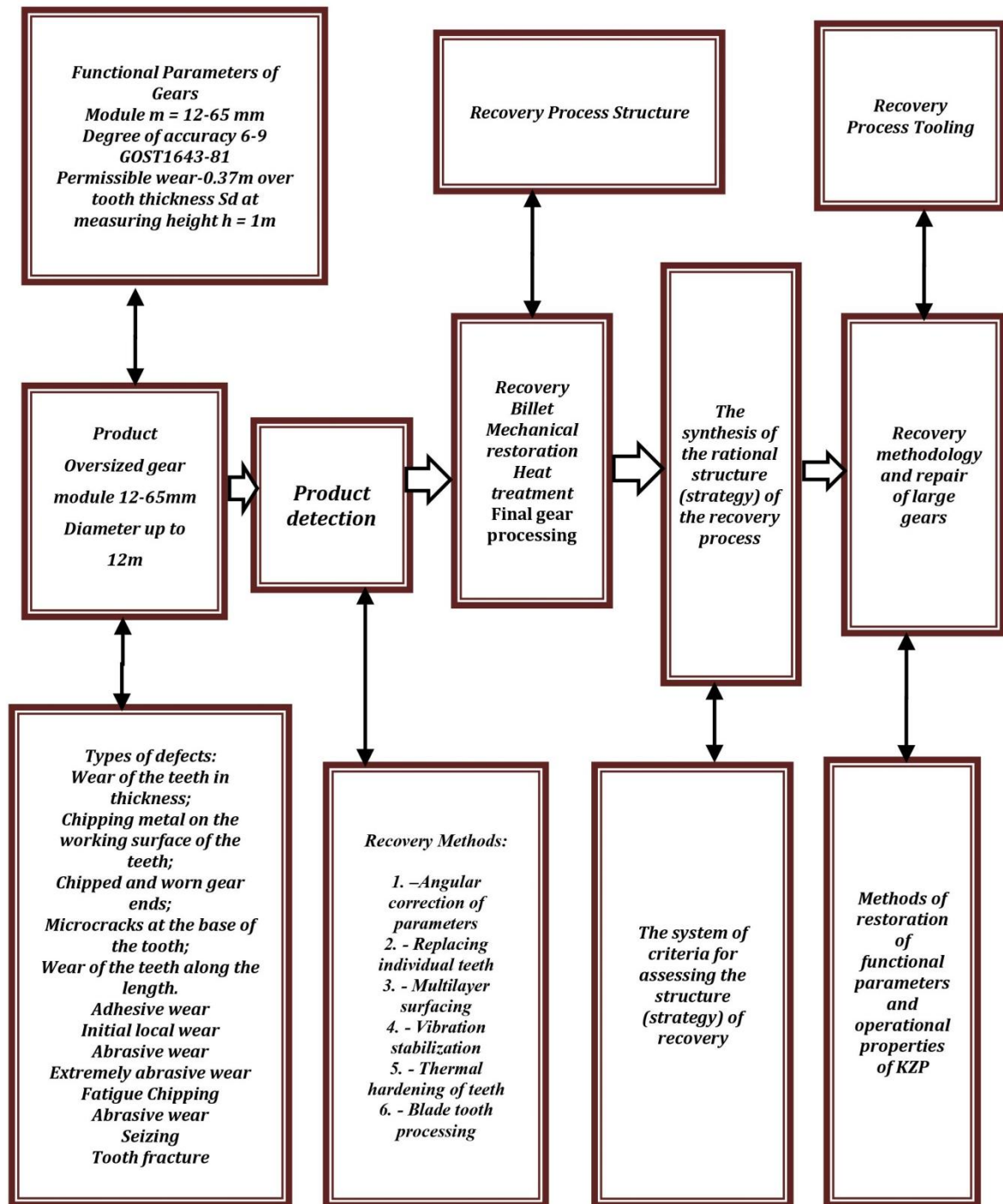

Fig. 3 – The structural-logical scheme of the dissertation of the process optimization of the technology for the restoration of large-sized gear rims of increased accuracy

A new technology for reconditioning large high precision cylindrical gears is suggested, where primary rough milling cutters with a modified face of a tooth with a prominence are used at the stage of pre-machining of the wheel teeth for strengthening and final speedy edge cutting machining of the tooth [7, 8].

For this purpose, the tip of a milling cutter (Fig. 4, a) has a tooth angle that differs from the standard one which is  $\alpha_0 = 20^\circ$  near the tooth tip and the tooth thickness is reduced by the allowance amount  $\Delta$  which is necessary for further final machining (Fig.4, b). The required allowance  $\Delta$  is left on the wheel teeth flanks after

machining by this milling cutter (Fig.4, b), while teeth inverts are machined adequately. The fact that the tips of a finishing tool, for example, tips of a grinding wheel, do not participate in cutting the inverts improves the process of cutting. Radial forces of cutting are reduced, vibration and springing of a tool decrease and, subsequently, its durability increases as well as the quality of the machined teeth.

The drawback of milling cutters with a prominence is the lowered angle ( $\alpha_3 = 1,5^\circ - 2^\circ$ ) on the tooth flank due to relieving work

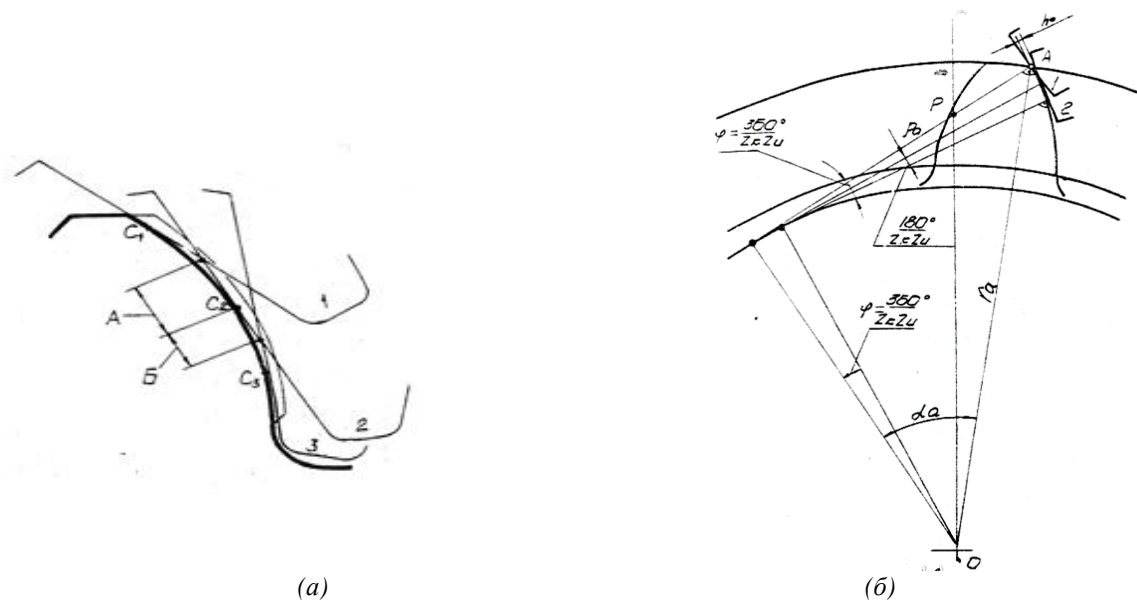

Fig. 4 – Wheel teeth precutting: a – a tooth of hob cutter with a prominence; b – a wheel tooth machined with  $\Delta$  allowance:  $h_n$  – the prominence height,  $a_0$  – the angle of original profile,  $a_n$  – the angle of prominence profile

The developed technique of pre-machining on the teeth of a large module ( $m = 20-25$  mm) was successfully tested for the first time while gear cutting the worn but reconditioned large gear rim with the following dimensions –  $D_a = 8058$  mm,  $m = 28$  mm;  $z_k = 284$ ;  $\beta_0 = 6^\circ 25'$ ;  $b_3 = 1000$  mm, produced of 35XMJ steel; 220-260 HB; the precision rate is 8-B GOST1643-81, which is used in the ore-pulverizing mill (Fig.5) of MB 90x30 model.

Gear hobbing was done by a special heavy vertical gear hobbing machine of KV-306 model with the

diameter of the operating face plate equal to 8000 mm. The fast-cutting hob cutter “Progress” was used for rough teeth cutting [7, 8, 9]. This cutter has an elongated starting taper ( $l_k = 350$  mm) and an expanded tool bore –  $\phi 100H7$ . According to the diagram given in Fig.1(a), a prominence is made on the teeth of a milling cutter (Fig.4); the teeth have complete profile heightwise. There are chip control flutes on the teeth of the starting taper, which enables separating box chips, i.e. escaping the space-limited cutting. This improves the tool durability.

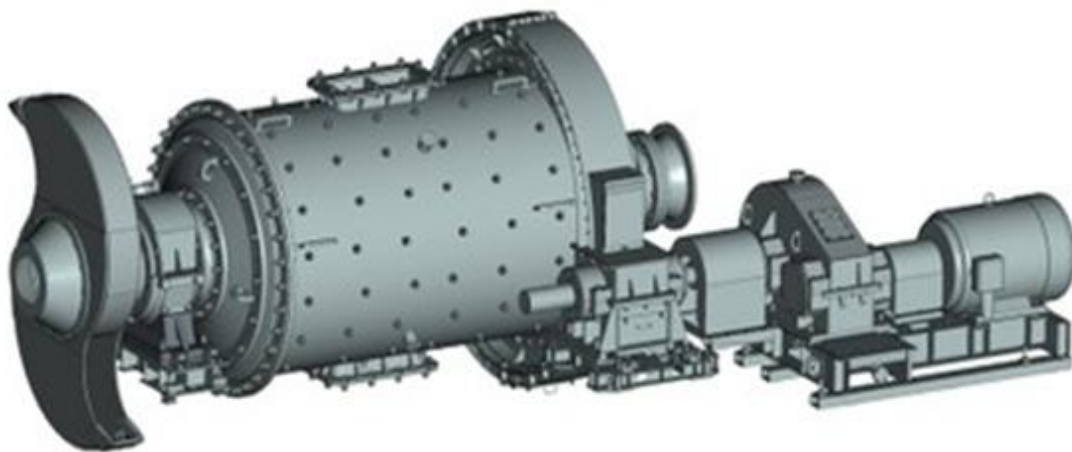

Fig. 5 – The general view of the ore-pulverizing mill of MB 90x30 model with the reconditioned gear rim with the following dimensions  $m = 28$  mm;  $z_k = 284$ ,  $D_a = 8058,4$  mm

The rough cutting modes were as follows: cutter feed  $S_\phi = 2,5$  mm/r; rotary velocity  $n_\phi = 0,2$  sec<sup>-1</sup>; the cutting direction is counter, metal cutting oil is “Industrial-20”. The machining time of rim cutting in one operation was 110 hours.

For reference: the time for machining this rim by other cutters, for example, by the “Frezer” plant is 350

hours.

The special hob cutter  $m = 28$  (Fig.6) was used for teeth finish machining in one operation, this cutter has hardmetal inserts made of BK 10-XOM alloy [7, 9, 10].

The cutting direction was counter, the cutting modes –  $t = 0,6$  mm,  $S_\phi = 3,86$  mm/r;  $n_\phi = 0,33$  sec<sup>-1</sup>.

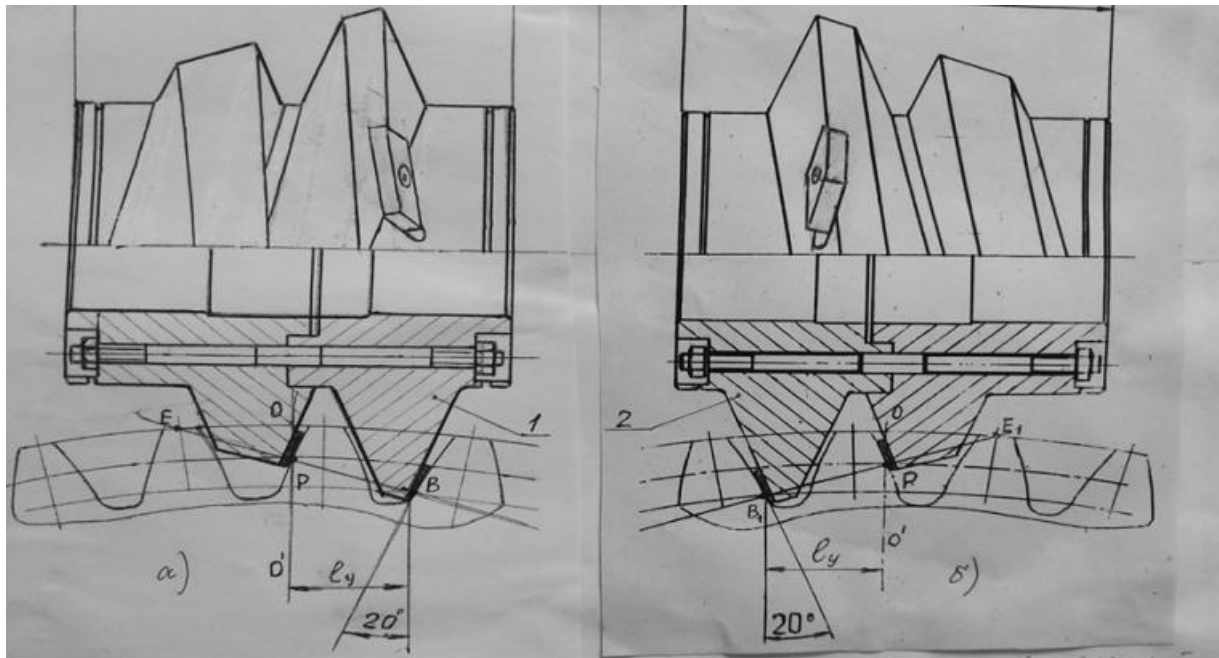

Fig. 6 – Special double hob cutter for two-way cutting ( $m=28$  mm);  $\alpha\phi=19^{\circ}20'$ .  
1-cutter housing; 2- distance ring

The machining time for finishing the rim was 65 hours. The maximum wear of the individual teeth of the milling cutter after this continuous working time did not exceed 0.3 mm, which is 4-5 times less than in the case of similar machining with high-speed cutters. The fact that the difference in the thickness of the teeth of the machined rim at the upper and lower ends ( $l_3 = 1000$  mm) did not exceed 0.06 mm indicates the high durability of the cutter. The measurement of the precision parameters of the cut teeth with attachable devices showed that the gear

corresponds to the 8th degree of precision in accordance with GOST 1643-81 in the context of the deviation of the circumferential pitch of the teeth and the pitch of the engagement.

**4. Materials and methods of the research.** The technique of rough and finishing teeth machining after the teeth (Fig.5) of large rims were reconditioned by rough cutters “Progress” with a prominence and a hardmetal finishing cutters (Fig.6) of a special design was introduced at PrAT “NKMZ”.

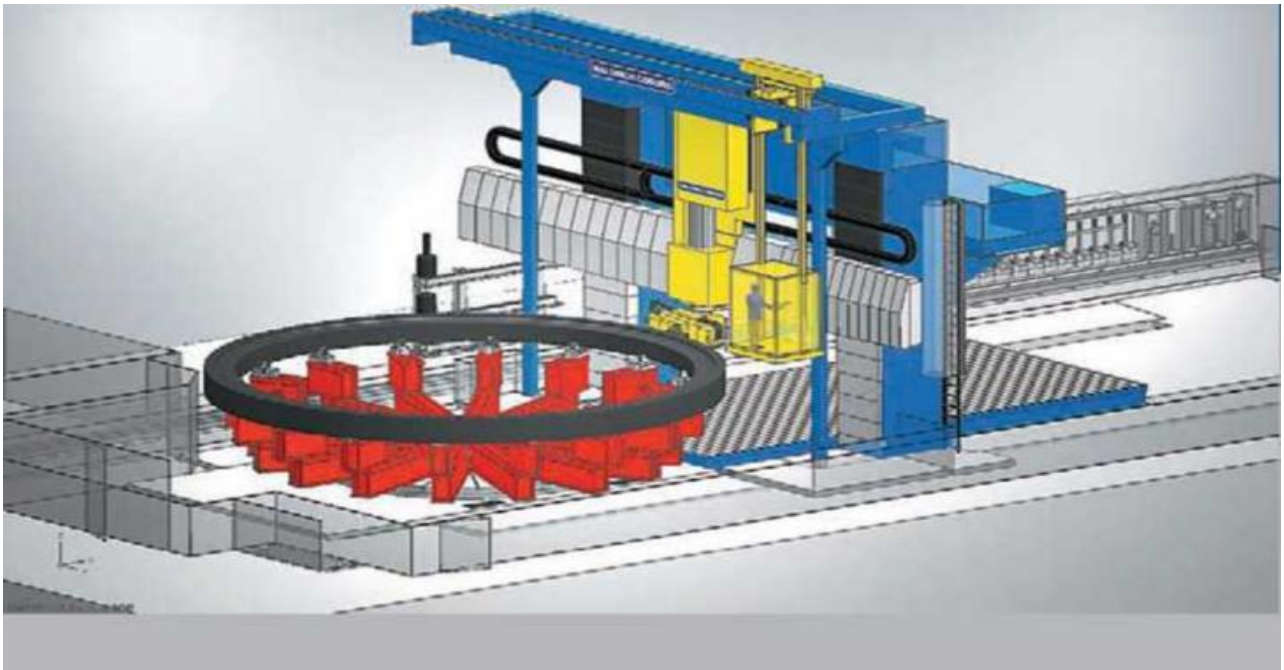

Fig. 7 – Finish cutting the rim teeth ( $m=20$  mm;  $Z_k=268$ ;  $\beta_3=5^{\circ}15'$ ;  $b=700$  mm; 140... 160 HB) using the machine of HHA-750 model (Japan)

The vertical gear hobbing machine of HHA-750A model manufactured by the firm "Shibaura" (Japan) (Fig. 7) was used for machining by counter milling with the use of metal cutting oil is "Industrial-20". The rim with the following parameters  $m=20$  mm;  $Z_k=268$ ;  $\beta_3=5^\circ 15'$ ;  $b=700$  mm; 35JIII steel; 140-160 HB was finished in one operation under the following modes of cutting –  $t=0,9$  mm;  $S_\phi=4,72$  mm/r;  $n_\phi=0,5$  sec<sup>-1</sup>;  $V_{pe3.}=32$  m/min.

The machining time for finishing one rim is 24 hours, which is by 1.8 times less than while machining by a high-speed cutter (Fig.8) (STP 4-15-70).

Fig. 9 shows chips cut during finishing of teeth with

a high-speed cutter without rough cutting by a cutter with a prominence. Most of the teeth of a finishing milling cutter cut the box chips; there is the space-limited cutting. In this case, the perimeter of the chips is approximately equal to half the perimeter of the wheel tooth which is 45-48 mm when the tooth module  $m=20$  mm. The tips of the individual teeth of the milling cutter cut thickened chips from the bottom of the tooth groove (Fig. 9, the upright row), which raises the radial cutting forces and leads to vibrations and springing of the tool, increases the wear of the teeth (Fig.10).

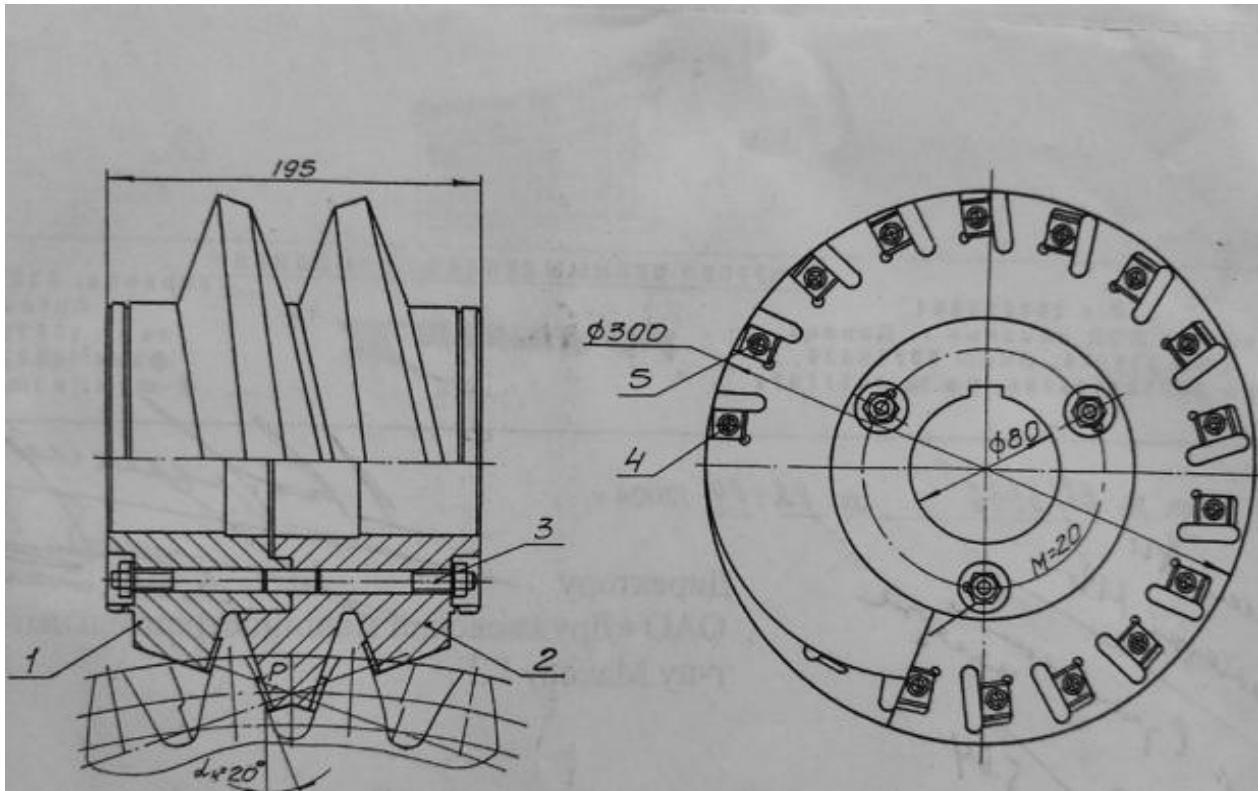

Fig. 8 – Finishing hardmetal hob cutter ( $m=20$  mm)

There are no box chips and the length of the chips does not exceed 10-16 mm while the length of the tooth cutting edge of the milling cutter is 20 mm. The length of the teeth cutting edge of the teeth in the developed designs of milling cutters does not exceed 20 mm and is the same for the modules with  $m=12-65$  mm. In this case, a number of teeth of the cutter is by 1.5-2 times greater than the milling cutters of other designs have.

Chips (Fig. 11) are compactly twisted, and their backside is shiny, which indicates a free cutting process, minor efforts and deformations in the SPEED system.

Hardmetal hob cutters with  $m=12-65$  mm (Fig. 12) that have disposable rotary tools made of BK 10-XOM alloy were designed to improve the milling cutter.

Under the factory conditions at the PrAT "NKMZ", hardmetal hob cutters with disposable rotary tools were designed and calculated by modelling and a solid model was obtained on SOLID WORKS programme. The control programme was further developed for machining

grooves for inserts that are tangentially placed using a numerically controlled machine tool manufactured by the firm "Ferrari" (Italy). The machining time for cutting the grooves of a cutter housing is  $T_{mach}=16-20$  hours.

Finishing the teeth of the worn and conditioned large gear rims can be further intensified by increasing the lobe configuration of hob cutters.

While gear machining, long-pitch multi-thread hob cutters ( $m>12$ ) of the standard design were not spread due to manufacturing complexity,

The designs of double-flute hardmetal hob cutters suggested in this work allow them to be used for machining the worn and conditioned large gear rims with the tooth module with  $m=12-40$  mm.

**5. The results of the research.** When a wheel is machined by a milling cutter with a number of teeth that is divisible by two, only a half of the wheel teeth can be fully machined in one operation. Therefore, after the first operation of the tool, the wheel should be rotated by one

angular pitch of the teeth and one more operation should be performed.

The design parameters of hob cutters, especially multi-flute ones, significantly affect the quality and precision of machining gears. In this regard, such parameters as faceting and waviness of the working involute flanks of the teeth are considered. Both the studied above designs of double-flute cutters and single-flute standard cutters of known designs ensure the same faceting and waviness on the wheel teeth flanks. 0.6-0.8 rotation of each flute is engaged in profiling the involute flank of the wheel teeth by double-flute milling cutters, while in the context of single-flute cutters 1.2 - 1.8 rotation are needed; however, the suggested double-flute cutters have a number of teeth placed along the rotation circuit that is twice as much.

The amount of calculated or geometrical waviness on the processed surface of the wheel teeth is calculated by a set of design parameters of the cutter and a workpiece that is machined, that is by the profile angle of the cutter, its dimensions, the helix angle of the wheel teeth and so on. To determine the magnitude of the geometric waviness, the equation of the path of the tooth cutting edge point of a hob double-flute cutter in relative motion can be used. The waviness parameter  $h_c$  on the machined surface of the wheel teeth can be determined by the coordinate of the point of intersection of the two projections of the cutter tooth path that are shifted relative to one another by the amount of the tool feed  $S$ . The initial dependence for determining the wave height  $h_b$  is:

$$h_b = 2r_k \cos\left(\beta - \frac{\gamma_6}{2}\right) \sin \frac{\gamma_6}{z_k} - r_\phi \sin \gamma_6 \sin \beta_y, \quad (1)$$

where  $r_k$  is the radius of the rotation of a wheel tooth point adjacent to the corresponding point of the cutter tooth;  $r_\phi$  is the radius of the rotation of the target point on the cutter tooth;  $\beta$  is the central angle corresponding to the distance from the machine axis to the target points of the pair "tool – workpiece";  $\gamma$  is the target angle of the wave formation;  $\beta_y$  is the angle of bringing a cutter in the machine support into operation position.

**Conclusions.** Industrial confirmation of The possibility and expediency of using hob cutter with a prominence ( $m = 20-28$  mm) while rough cutting of worn and reconditioned large gear rims were proved industrially. To obtain the required durability of roughing milling cutters, it is recommended that the angle of the prominence profile be set at  $8^\circ - 10^\circ$ .

The use of hardmetal hob cutters for finishing enables increasing the performance rate by 2 to 3 times in comparison with high-speed cutters of other designs and makes it possible obtain the required quality and precision of manufacturing worn and reconditioned large gear rims.

The technology of optimization of reconditioning large high-precision gear rims with the use of the design of special and universal hardmetal single- and double-flute cutters with both re-sharpened cutting elements and with disposable rotary tools turn plates was developed and introduced.

#### References

- Klochko, A., Shelkovoy, A., Shapovalov, V., Belovol, A., Antsyferova, O. (2017), "Technology of repair and restoration of large-modular hardened gears by high-speed blade processing". Innovative Technologies & Scientific Solutions for Industries. Kharkiv. No. 2 (2). P. 38–47.
- Kovalev, V., Shelkovoy, A., Klochko, A. (2017). "Technological solutions of the stationary task of working liquids for increasing the durability of gear wheels of the main drives of heavy turning machines". The current state of scientific research and technology in the industry. Kharkiv No. 1 (1). P. 36–45.
- Belovol, A., Klochko, A., Naboka, E., Skorkin, A., edited by A. Shelkovoy (2016), *Imitation modeling in problems of machine-building production in 2 volumes*, T. 1: study. Allowance Kharkiv NTU "KhPI". 400 p. ISBN 978-966-593-749-4.
- Shelkovoy, A., Klochko, A., Hasanov, M. (2017), "Maintenance of operational properties of hardened gears". Bulletin of modern technologies: Sat. scientific tr Sevastopol: FSUE "Sevastopol State University". Issue 8. P. 61–70.
- Shelkovoy, A., Permyakov, A., Novikov, F., Voloshin, A., Klochko, A., Hasanov, M. (2017), "Actuality of differentiated and integrated forecasting in conditions of simulation of technological support of operational properties of surfaces of large-sized gear wheels". Physical and computer technologies. Proceedings of the 23rd International Scientific and Practical Conference. December 21-22, 2017, Kharkov. Odessa: ONPU. P. 36–41.
- Kapelevich, A.L. *Direct Gear Design*. CRC Press, 2013
- Permyakov, A., Shelkovoy, A., Klochko, A., Okhrimenko, A. (2017), «Modern technologies of increasing durability of cylindrical gears». XVII International Scientific and Technical Conference "Progressive Technology, Technology and Engineering Education", which took place June 29-July 01, 2017, at the National Technical University of Ukraine "Igor Sikorsky Kiev Polytechnic Institute". Kyiv: NTUU "KPI". T. 4. P. 348–350.
- Starzhinsky, V., Soliterman, Yu., Tesker, E., Goman, A., Osipenko, S. (2008), "Types of damage to gears: typology and recommendations for the prevention of damage", Friction and wear. Gomel. T. 29. № 5. P. 465–482.
- Kapelevich, A. L., A. I. Tolchenov and A. I. Eidinov. 1985. *Application of the fly cutters in experimental production*, Aviatcionnaya Promyshlennost. #3. 39-40.
- Kapelevich, A. L., Y. V. Shekhtman and T. M. McNamara. 2005. *Turning an Art into Science*. Motion System Design. August: 26-31.
- Mironenko, E., Shapovalov, V., Klochko, A., Palashek, S., Ostapovich, E. (2015), "Design and technological methods of increasing the productivity and quality of the tooth processing of large-sized gears. Bulletin of the NTU "KhPI". Series: Technology in Mechanical Engineering. Kh.: NTU "KhPI". No. 4 (1113). P. 28–32. ISSN 2079-004X.
- Timofeev, Yu., Shapovalov, V., Klochko, A. and others. (2011), *Special technologies of zebot machining of large-modular hardened wheels*: monograph. Kramatorsk: DGMA. 128 p.
- Timofeev, Yu., Kane, Yu., Klochko, A., Shapovalov, V. and others. (2014), *Technological bases of a toothprocessing of hardened large-modular gear wheels*: a monograph. Kramatorsk, DHSA. 479 p.
- Mironenko, E., Klochko, A., Shapovalov, V., Chmyrov, V. (2013), "Perfection of the technology of a toothbrush by worm modular cutters with contact-reactive soldering of cutting plates". Reliability of the tool and optimization of technological systems: ser. scientific tr Kramatorsk: DGMA. Issue 33. P. 3–7.
- F.W. Brown, S.R. Davidson, D.B. Hanes, D.J. Weires, and A. L. Kapelevich, 2010, "Analysis and Testing of Gears with Asymmetric Involute Tooth Form and Optimized Fillet Form for Potential Application in Helicopter Main Drives", AGMA Fall Technical Meeting, Milwaukee, Wisconsin, October 18-19, (10FTM14)
- Suslov, A., Klochko, A. (2016), "General principles of modeling of optimal control of parameters of accuracy, quality and productivity of tooth processing of hardened large-modular

*gears*". Problems of designing and automation in mechanical engineering. Collection of scientific works. Scientific and Production Cooperative "Oniks". Irbit: NPK ONIS. P. 105–119. ISBN 978-5-906703-10-1.

Поступила (received) 15.05.2020

*About the Authors / Відомості про авторів / Сведения об авторах*

**Hasanov Magomedemin (Гасанов Магомедємін Ісамагомедовіч, Гасанов Магомедємин Исамагомедович,)** – проректор по науково-педагогічній роботі, доктор технічних наук, професор кафедри технологія машинобудування і металорізальні верстати, Національного технічного університету «Харківський політехнічний університет», м. Харків;; тел.: (096)-590-8850; e-mail: kh.kajvika@gmail.com;

**Permyakov Alexander (Пермяков Олександр Анатолійович, Пермяков Александр Анатольевич)** – доктор технічних наук, професор, завідувач кафедри технології машинобудування та металорізальних верста-тів Національного технічного університету «Харківський політехнічний інститут», м. Харків, Україна; тел.: (057) 720-66-25, ORCID: 0000-0002-9589-0194

**Klochko Alexander (Клочко Олександр Олександрович, Клочко Александр Александрович)** – доктор технічних наук, професор кафедри технологія машинобудування і металорізальні верстати Національного технічного університету «Харківський політехнічний університет», м. Харків; тел.: (067) 936-36-64; e-mail: ukrstanko21@ukr.net, ORCID: 0000-0003-2841-9455;

**Shelkovoy Alexander (Шелковой Олександр Миколайович, Шелковой Александр Николаевич)** – доктор технічних наук, професор, завідувач кафедри інтегровані технології машинобудування ім. М.Ф.Семка Національного технічного університету «Харківський політехнічний університет», м. Харків; тел.: (050) 945-28-93; e-mail: alnikshelk@gmail.com, ORCID:0000-0002-7414-4854.