

**UCC Library and UCC researchers have made this item openly available. Please [let us know](#) how this has helped you. Thanks!**

<b>Title</b>	State forecasting and operational planning for distribution network energy management systems
<b>Author(s)</b>	Hayes, Barry P.; Prodanovic, Milan
<b>Publication date</b>	2015-10-30
<b>Original citation</b>	Hayes, B. P. and Prodanovic, M. (2016) 'State Forecasting and Operational Planning for Distribution Network Energy Management Systems', IEEE Transactions on Smart Grid, 7 (2), pp. 1002-1011. doi: 10.1109/TSG.2015.2489700
<b>Type of publication</b>	Article (peer-reviewed)
<b>Link to publisher's version</b>	<a href="https://ieeexplore.ieee.org/document/7313029">https://ieeexplore.ieee.org/document/7313029</a> <a href="http://dx.doi.org/10.1109/TSG.2015.2489700">http://dx.doi.org/10.1109/TSG.2015.2489700</a> Access to the full text of the published version may require a subscription.
<b>Rights</b>	<b>© 2015 IEEE. Personal use of this material is permitted. Permission from IEEE must be obtained for all other uses, in any current or future media, including reprinting/republishing this material for advertising or promotional purposes, creating new collective works, for resale or redistribution to servers or lists, or reuse of any copyrighted component of this work in other works.</b>
<b>Item downloaded from</b>	<a href="http://hdl.handle.net/10468/10394">http://hdl.handle.net/10468/10394</a>

Downloaded on 2021-11-27T11:57:32Z



**UCC**

University College Cork, Ireland  
Coláiste na hOllscoile Corcaigh

# State Forecasting and Operational Planning for Distribution Network Energy Management Systems

Barry Patrick Hayes, *Member, IEEE* and Milan Prodanovic, *Member, IEEE*.

**Abstract**—This paper describes the application of Advanced Metering Infrastructure (AMI) data for developing energy forecasting and operational planning services in distribution networks with significant distributed energy resources. The paper describes development of three services designed for use in distribution network energy management systems. These comprise of a demand forecasting service, an approach for constraint management in distribution networks, and a service for forecasting voltage profiles in the LV network. These services could be applied as part of an advanced distribution network management system, in order to improve situational awareness and provide early warning of potential network issues. The methodology and its applicability is demonstrated using recorded SCADA and smart meter data from an existing MV distribution network.

**Index Terms**—Distributed energy management systems, demand forecasting, advanced metering infrastructure, power system monitoring, distributed energy resources.

## I. INTRODUCTION

**D**ISTRIBUTION networks have traditionally been designed and operated as passive, radial systems, in which power flows are relatively easy to predict and manage. Recently, distribution networks have seen increasing penetrations of Distributed Energy Resources (DER), such as small to medium-sized Distributed Generation (DG), demand-responsive loads, electric vehicles, devices with storage capability, and microgrids. All relevant studies suggest that such trends towards more actively-managed distribution systems are set to continue, and that the integration of these technologies will lead to more frequent occurrences of problems in the distribution network, such as congestions and excessive voltage variations [1], [2]. This has led to research interest in adapting network management techniques, previously only used at the transmission level to distribution systems, such as state estimation and short-term operational planning [3]–[6].

This paper discusses the application of AMI data for forecasting future network states, and the application of short-term operational planning to distribution systems with significant DER. The presented approach is designed to provide early warning of potential network issues to the Distribution System Operator (DSO), and allow for more optimal management of embedded DER. In order to estimate the future operational states of the distribution system, expected net demand profiles (e.g. combined demand and photovoltaic (PV) generation) are estimated using short-term load forecasting techniques. These

forecasts, along with the expected network configuration, are used to provide an assessment of the network operating state, indicating one of the following: normal operation; a “warning” state indicating that the network is close to operational limits; or an “alarm” state, indicating that network constraints are expected to be violated, unless corrective action is taken. The capacity of embedded DER (e.g. demand-responsive load) to allow for management of network constraints and improvement of overall system reliability is also quantified. The main contribution of this paper is the development of three “services” which can be applied in short-term operational planning of distribution systems. These can be summarised as follows:

- Demand forecasting service: estimates hours/days-ahead net demand (combined load and PV) profiles at the MV distribution network substation level.
- Constraint management service: optimises allocation of DER, such as demand-responsive loads. This service maximises the amount of reserve available from DER for use in overall system energy management, while meeting all local network constraints.
- Voltage estimation service: uses historical AMI data to forecast voltage profiles in the LV network hours/days ahead. This service can be used to provide the DSO with early warning of potential voltage issues.

The presented services are intended to improve situational awareness and energy management at the local distribution network level. The paper focuses on developing techniques for short-term operational planning that can operate automatically, with minimal intervention from the network operator. This is expected to reduce the workload required to manage energy resources in distribution systems, which are often complex, diverse, and dispersed over large geographical areas. The proposed methods are tested using recorded data from an existing MV distribution network [7]. At this network, detailed recordings of demand and local generation were available over a continuous period of two years at both the MV substation and end-user (e.g. home/factory) level.

The paper is structured as follows. Section II gives a brief literature review and discussion of the current state of the art, in order to put the contribution of this paper into context. Section III presents the methodology, including the development of each of the proposed services. Section IV gives the results, and lastly, conclusions are drawn in Section V.

## II. STATE OF THE ART

Increasing penetrations of DER have led to a requirement for improved observability and situational awareness in distri-

The authors are with the IMDEA Energy Institute, Avda. Ramón de la Sagra, Móstoles Technology Park, Madrid 28935, Spain. Corresponding author e-mail: barry.hayes@imdea.org.

bution systems. State Estimation (SE) is an important tool in this context. SE has been a critical part of the operation and management of transmission systems for many years, it has not been widely implemented at the distribution level, due to a lack of monitoring and communications infrastructure, and due to the fact that most distribution systems have been operated passively. Recently, there has been significant research interest in decentralised SE methods [8]–[14] and algorithms for Distribution System State Estimation (DSSE), e.g. [15]–[20]. In this paper, the DSSE algorithm described in [21] is used to calculate the network states.

A number of studies have investigated advanced Distribution Management Systems (DMS), designed to optimise energy management in distribution networks [22]–[24], and in particular, the use of DER for energy management, both within the distribution network, and contributing to overall grid energy balancing [25]–[28]. These DER may be in the form of demand-responsive loads, or other resources, such as controllable DG, electrical vehicles or storage devices. In distribution systems, the application of DER for energy management typically involves the aggregation of highly-dispersed resources at the end-user level, applied via direct control of DER (e.g. switching of smart appliances), or indirectly through a user response to a price signal [27], [28]. The work presented in this paper is focused on the application of DER to energy management at the distribution network level. It is assumed that a certain amount of “manageable” energy resources are available at each network node. However, the enabling communications infrastructure, or the electricity market mechanisms required to implement specific ‘demand response actions, are out of scope of this paper.

The estimation, or prediction of load profiles is particularly important for operational planning in distribution systems. Load estimation techniques have been applied in distribution systems in [29]–[38], in order to provide inputs to DSSE, with the aim of enhancing observability where the number of real measurements available in the network is insufficient. The widespread introduction of smart meters means that an unprecedented amount of detailed historical data on user loads is becoming available. This data can be used to better understand and model the behaviour of distribution network loads, allowing to improve load estimation techniques. Several papers have explored the use of LV smart meter data for this application [39]–[42]. In this paper, models are developed for forecasting load and DG behaviour at the distribution substation level using recorded smart meter data, in order to support DSO short-term operational planning.

### III. METHODOLOGY

This section describes the proposed methodology for state forecasting and short-term operational planning in distribution networks. The approach focuses on developing “services”, which are designed to be scalable and applicable in any given distribution system. A flowchart representation of the overall approach is shown in Fig. 1, with the three proposed services highlighted. Each service is described in detail in the subsections below.

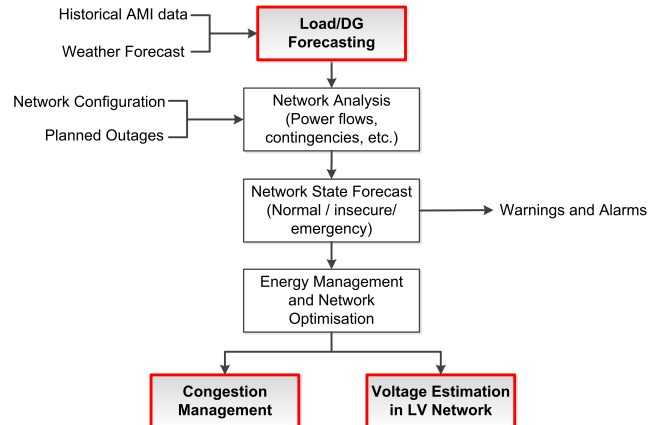

Fig. 1. Flowchart representation of overall methodology, with proposed services highlighted.

#### A. Demand Forecasting Service

The forecasting of future network states requires high-quality estimates of demands and DG output profiles at each network node. In this paper, various methods were tested and compared for the short-term load forecasting of the “net demand” (i.e. load and DG combined) at the distribution substation level for this purpose. A number of techniques have been previously applied for short-term load forecasting, including auto-regressive and neural network based models [43]–[46]. Most previous work in the area of short-term load forecasting applies to large, aggregated loads, e.g. prediction of regional or national demands. Recently, there has been interest in load forecasting at much more localised level for smart grid applications, e.g. [39]–[42]. For local-level load estimation, demands are highly variable and difficult to predict with accuracy. The presented methodology focuses on short-term load forecasting at secondary (MV/LV) distribution substations, with few tens to hundreds of customers.

1) *Description of Data Set:* The analysis in this paper uses recorded demand and rooftop-mounted PV output data from MV/LV substations in the case study network (see Section IV-A for details of the network). The data set comprises of 24 months of continuous recordings of hourly consumption and production at 46 MV/LV substations, made up of aggregated smart meter recordings. 12 of the substations have significant PV installed in the LV networks, and PV production is recorded separately to by the smart metering system. Weather data for the area of interest (historical and forecast information) was obtained by request from the Danish Meteorological Institute [47]. For the analysis, the entire data set was split into model training data (50%), and model validation data (the remaining 50% of the recordings, making 12 months of out-of-sample data).

2) *Selection of Load Estimation Model:* Several forecasting models were applied to estimate the net demand at 46 individual demand points, where a separate model is trained and tested for each *individual* MV node. The above data were used to estimate both demand and PV output using the following load forecasting techniques:

- **NAIVE:** A “naive” load forecast is made by simply

taking the same hour, previous day demand value. For weekends, the same hour from the most recent weekend day is taken instead.

- **ARX**: Linear Auto-Regressive eXogenous (ARX) model.
- **NN**: Non-linear Neural Network (NN) model.
- **LMS**: Linear regressive model using the Least Mean Squares (LMS) algorithm.
- **NARX**: Non-linear Auto-Regressive eXogenous (NARX) model.

Fig. 2 compares the results for 24 hour-ahead forecasting. The demand forecasting performance in each case is expressed as the average Mean Absolute Percentage Error ( $MAPE_{ave}$ ), calculated over all 46 nodes for the 12 months of validation data:

$$MAPE_{ave} = \frac{1}{N} \sum_{n=1}^N \left( \frac{1}{T_n} \sum_{t=1}^{T_n} \left| \frac{A_t - F_t}{A_t} \right| \right) \quad (1)$$

where  $N$  is the total number of demand nodes,  $T_n$  is the total number of time steps in the recorded data at node  $n$ ,  $A_t$  and  $F_t$  are the actual and forecasted demands recorded at each time step  $t$ . It can be seen from Fig. 2 that the ‘‘NARX’’ model demonstrates the best overall performance for this application. The NARX model was selected for all further analysis in this paper, and is described below. Due to space limitations, the other models (LMS, ARX and NN) are not discussed in detail, the reader is instead referred to the literature on load estimation in [43], [45], [46], [48], [49].

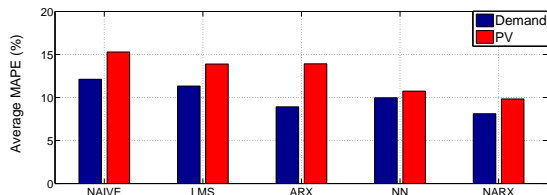

Fig. 2. Comparison of 24-hour ahead forecasting errors at 46 individual MV distribution network demand points.

3) *Description of NARX Model*: The NARX model is expressed as:

$$y_{t+1} = F(u_t, u_{t-1}, \dots, u_{t-d_i}, y_t, y_{t-1}, \dots, y_{t-d_o}) \quad (2)$$

where the next value of the output signal (e.g. the kW load),  $y_{t+1}$ , is regressed using previous load measurement values  $y_t, y_{t-1}, \dots$  and input signals  $u_t, u_{t-1}, \dots$ , (e.g. weather, time-related and historical load variables). The function  $F$  represents a neural network, where the weights for each connection in the network are trained in MatLab using the Levenberg-Marquardt back-propagation algorithm. The number of time delays in the input and output layers are denoted  $d_i$  and  $d_o$  respectively. These can be adjusted to allow for different forecasting horizons, e.g. hour-ahead, day-ahead etc. For example, to calculate the 24 hour-ahead forecast,  $y_{t24}$ , for a given node (assuming that all of the required variables are available from the previous 24 hours), (2) is re-formulated as:

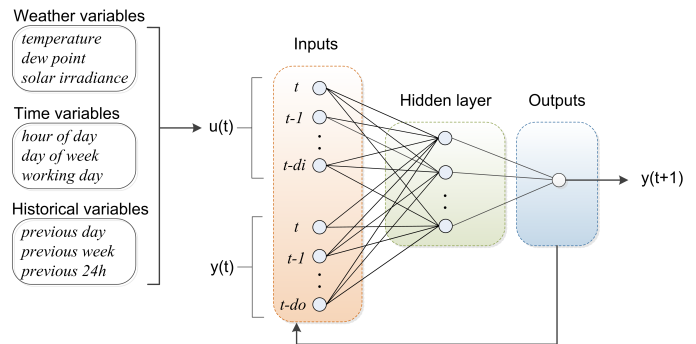

Fig. 3. Structure of the NARX net demand forecasting model.

$$y_{t24} = F(u_{t-24}, u_{t-25}, \dots, u_{t-48}, y_{t-24}, y_{t-25}, \dots, y_{t-48}) \quad (3)$$

The structure of the proposed NARX model for forecasting net substation demand is illustrated in Fig. 3. The input signals  $u_t$  are specified as follows:

- three weather forecast variables: temperature and dew point (both measured in  $^{\circ}\text{C}$ ), and solar irradiance in  $\text{W}/\text{m}^2$ , which was used to estimate the impact of PV on net demand<sup>1</sup>.
- three time-related variables: these consist of variables for hour of day  $H_t = [1, 2, \dots, 24]$ , day of the week  $D_t = [1, 2, \dots, 7]$ , and a variable  $W_t = 1$  or 0, where 1 indicates a working day, and 0 indicates a non-working day, such as a weekend or bank holiday.
- three historical demand variables which have a strong correlation with the demand profile: the recorded demand at the same hour demand of the previous day, the same hour of the previous week, and the previous 24-hour average demand level.

The proposed NARX model in Fig. 3 forecasts the *net demand*, i.e. the combined demand consumption and PV production profile at each node. It was found that directly forecasting the net demand using the NARX model produced the same level of accuracy as creating separate NARX forecasts of demand and PV at each MV/LV substation (see the results of the demand forecasting in Section IV-B).

The average NARX training time for each network node was around 1.3 seconds (using a standard PC with a 2.6 Ghz microprocessor). The best results were obtained using a feed-forward NARX model, comprised of an input layer with 9 neurons (one for each input variable), one hidden layer with 10 neurons, and an output layer with one neuron. Detailed results of the demand forecasting service are given in Section IV-B.

### B. Network State Forecasting and Analysis

The future states of the network can be estimated using the forecasted power injections at each node, along with the expected network configuration, Fig. 1. A short-term

<sup>1</sup>Other weather variables, such as precipitation and wind speed were recorded and analysed, but it was found that these did not have a significant impact on net demand.

planning approach, similar to the standard procedures used by Transmission System Operators (TSOs) for hours/days-ahead operational planning is proposed in this context. The input data should include expected network configuration changes due to e.g. scheduled maintenance on distribution system components, or other expected changes to substation running arrangements etc.). Network analysis, including power flows, contingency and fault analysis, is carried out for the relevant time-frame (e.g. peak hour day-ahead), in order to estimate the future network state. Appropriate warnings and alarms are issued if constraint violations are predicted, providing early warning of potential issues to the DSO.

In transmission network operation, the overall status of the system is often described according to the “operating state” categories (e.g. secure, alert, emergency, in extremis) originally proposed in [50]. A similar idea is applied to distribution network operation in [51], where the overall network state is described in one of three categories, which are used to direct DSO decisions around corrective actions.

- **Normal:** Normal network operation, no action required.
- **Insecure:** Network operating close to allowed limits, potential for violation of system constraints. In this case, the DSO could apply market-based incentives to adapt network production/consumption to the network situation.
- **Emergency:** Network constraints are violated, direct load management or DG curtailment is required to return network to a secure operating state.

In this paper, an “operating state” approach is used to provide a simple, qualitative estimate of the future network state. Based on this assessment, decision around taking actions to resolve potential network constraints can be proposed and tested ahead of time. The analysis could also be extended to include the regulations around reliability and quality of supply. In many countries and regions, financial penalties are applied to the DSO in the event that network end-users are disconnected. The penalties typically vary according to the number and length of time for which customers are disconnected from the network. These penalties could be incorporated into the analysis according to the approach in [52], [53], allowing the DSO to prioritise certain corrective actions, based on the risk associated with each network contingency.

### C. Constraint Management using Distributed Energy Resources

While the majority of existing distribution networks are operated radially, with few options for reconfiguration, there has been much interest in active distribution network management in recent years, e.g. [1]–[6]. With the large-scale integration of DER, it is expected that the frequency and severity of network constraint problems will increase, and that methods which have previously only been applied at the transmission level, such as constraint management, may become relevant to some distribution systems.

In this section, a general methodology for distribution system constraint management using embedded DER is proposed. In any distribution system, the type of network constraint issues, and the extent of the required constraint management

depends on the network characteristics, the mix of embedded DER, and the local regulatory and market environment, which can make it difficult to generalise the problem. In the analysis below, it is assumed that we have a meshed distribution network, and that some “demand response” capability at the end-user level is available for use in constraint management by the network operator. This demand-responsive part of load is considered simply as negative load, without considering the underlying communication and control technologies and market mechanisms required to enable the demand response actions.

In [6], it was demonstrated that the *network location* of each demand-responsive load has an impact on its ability to contribute to the management of system constraints, and the improvement of overall system energy balancing and reliability. Hence, when considering the application of demand response, it is important to consider the contribution of each load to both local network constraints and overall network energy balancing. The following describes a method for optimising the application of demand-response loads in a distribution system, in order to provide the maximum contribution to energy balancing, whilst also managing local network constraints. This approach could be applied by operators of active distribution networks in order to design demand response schemes, and provide the appropriate incentives to encourage the development of demand response at the optimal network locations. The problem is formulated as an Optimal Power Flow (OPF), in which the objective function is to minimise the amount of load adjustment required to satisfy the network constraints:

$$\min \sum_{n=1}^{N_{loads}} C_n \cdot P_{n,init}(1 - \Psi_n) \quad (4)$$

where  $N_{loads}$  is the number of network load buses where demand response can be applied,  $P_{n,init}$  is the initial active power of bus load  $n$  in MW, and  $\Psi_n$  represents the load adjustment factor, or the portion of the initial MW load at bus  $n$  which is available for deferral.  $C_n$  is the cost of load adjustment assigned to the demand-responsive load at bus  $n$ , in cost units per unit MW. In the analysis presented in this paper,  $C$  is not given a monetary value. Instead it is set to an arbitrary value of 1.0 per MW for all of the loads. However, if required, this can be adjusted to allow prices to be set for the various demand response services that can be offered in a given network.

A full AC-OPF is applied assuming balanced, steady-state conditions, subject to the power flow balance constraints. The OPF needs to satisfy bus voltage constraints (5), line thermal constraints (6), and constraints on the load adjustment factors at each DSM-enabled bus (7):

$$V_{min,n} \leq V_n \leq V_{max,n} \quad (5)$$

$$|S_k| \leq |S_{max,k}| \quad (6)$$

$$\Psi_{min,n} \leq \Psi_n \leq \Psi_{max,n} \quad (7)$$

where  $V_{min,n}$  and  $V_{max,n}$  are the minimum and maximum allowed voltages at each network bus  $n$  (including non-load buses),  $S_k$  is MVA power flow through network branch  $k$ , and  $\Psi_{min,n}$  and  $\Psi_{max,n}$  are minimum and maximum load adjustment factors for each load at bus  $n$  (based on the proportion of demand-responsive load available).

For instance, if we have a scenario where there a thermal constraint (6) at line  $k$  in a meshed distribution network, the demand response action could be potentially be applied at any location in the network where demand-responsive load is available. The effectiveness of any individual bus depends on its location in the network relative to the constraint. It is possible to compare the effectiveness of various buses for relieving the constraint. For example bus  $i$  may be  $E\%$  more effective than bus  $j$  at relieving constraint  $k$ , where this “effectiveness”,  $E_k$  is expressed as:

$$E_k(\%) = 100 \times \left( \frac{\Delta P_{i,init}(1 - \Psi_i)}{\Delta P_{j,init}(1 - \Psi_j)} \right) \quad (8)$$

In general, it is desirable to minimise the total amount of load deferral, and the logical solution is to prioritise bus(es) with a higher value of  $E_k$  to relieve the constraint. In a large distribution network, where various combinations of deferrable loads could potentially be used to satisfy multiple constraints, a systematic method is needed to carry out this demand-response allocation.

The OPF formulation in (4)-(7) allows the user to consider the embedded demand response resources at each network node, as well as all of the local network constraints, when applying demand response actions. The applicability of this approach is illustrated by example in Section IV-C of this paper.

#### D. Voltage Estimation and Forecasting in LV Network

Recorded AMI data from smart meters and other sensors in the LV network can be applied to provide estimates of the voltages in the LV network, where no direct voltage measurements are available. The approach described below demonstrates the application of the demand forecasting methods described in Section III-A to provide a probabilistic estimate of voltage profiles in the LV system, warning the network operator if limits are expected to be violated. Fig. 4 shows a section of a typical radial LV network, where recordings of consumption and production are available at the MV substation by means of SCADA measurements, and through AMI in the form of smart meter measurements at each individual end-user. It is assumed in the analysis that the smart meters only log kW active power consumption and production at each end-user at regular intervals, and do not have any voltage or power quality measurement capabilities.

The objective of the estimation is to determine the expected range of voltages at each node along the main LV feeder  $V_1, V_2, \dots, V_N$ , Fig. 4. In Section III-A, forecasts of demand and production are made at the MV substation level. The proportion of the estimated demand and production at each LV node (this may correspond to e.g. group of nearby residential customers, or a factory) is obtained from the AMI data. This

is calculated using the total contribution from each load group recorded in the previous working day (or the previous weekend/holiday where appropriate)<sup>2</sup>. The voltage at each node of interest can be estimated by using the forecasted demand and consumption with a standard network state estimation algorithm (this paper uses the SE developed in [21]). In order to simplify the analysis, it is assumed that the loads are balanced across the three phases, and the loads are represented as constant active/reactive power demands, with no voltage dependency.

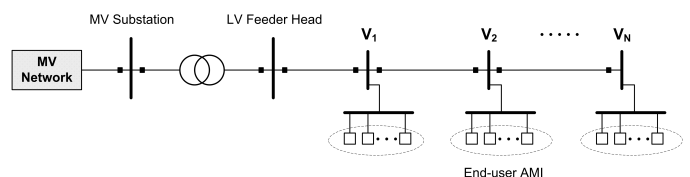

Fig. 4. Estimation of LV network node voltages using energy demand and production forecasts.

Rather than giving a point estimate of the voltages, a probabilistic estimate is made, which takes into account the historical error distribution of the demand forecasting. The demand forecasting error vector for bus  $n$  is given by:

$$\mathbf{e}_n = A_t - F_t \quad \text{for } t = 1, 2, \dots, T \quad (9)$$

where  $T$  is the total number of available actual and forecasted data points at that bus. This demand forecasting error varies according to hourly and seasonal factors (see results in Section IV-B). In order to create confidence intervals around the forecast, the *percentile errors* for each hour and for each month are applied to each forecast. For example, the 90% confidence interval for a single point demand forecast  $y_t$  is given by:

$$C_{90} = -\pi_{95} \leq y_t \leq \pi_{95} \quad (10)$$

where  $\pi_{95}$  is the 95<sup>th</sup> percentile of  $\mathbf{e}_n$ . The advantage of using a non-parametric approach with percentiles is that the method is independent of the probability distribution of the demand forecasting errors. However, it is assumed that sufficient historical data (e.g. at least several months of hourly data) is available in order to estimate the error percentiles with a reasonable degree of accuracy.

This analysis can be used to forecast the range of possible voltage profiles ahead of time in parts of the LV network where no sensors are available. This can be used to provide early warning of voltage issues at the end-user level, and allow the network operator to consider pro-active measures such as: (i) adjustment of settings on reactive compensation equipment; (ii) changing tap settings on HV/MV transformers (on-load) or MV/LV transformers (off-load); or (iii) application of demand-response measures, or (iv) direct control/disconnection of load and/or DG. The estimation of LV network voltages is demonstrated using recorded AMI data from the case study network in Section IV-D.

<sup>2</sup>This approach is preferred to attempting the forecasting of load and DG at the individual user, or group of individuals, since accurate demand forecasting becomes increasing difficult as the level of aggregation decreases [5], [21], [48].

## IV. RESULTS

### A. Description of Case Study Network

The services described in this paper are demonstrated using an existing distribution network, which is the test network from the SmartHG EU project [7]. The MV network comprises of a 48-bus, 10kV system with a weakly-meshed structure, Fig. 5. The network has a peak demand of 3.2 MW, which is made up primarily of suburban/rural residential customers (77% of total demand). The remainder of the network demand is comprised of factories, and some district heating and street lighting loads. There is also significant embedded PV generation, at the 12 locations in the network indicated in Fig. 5. Recordings of demand consumption and PV production from both the MV SCADA and LV smart metering systems were available throughout the network for a continuous period of 24 months. This network is a new, well-designed MV distribution system with significant network capacity for further addition of load and DER. In order to create more scenarios where the network is operated close to its physical limits, requiring active management of network issues from the DSO, the active and reactive power demands throughout the entire network were scaled by a factor of 1.5, and the penetration of PV was increased by a factor of 2.

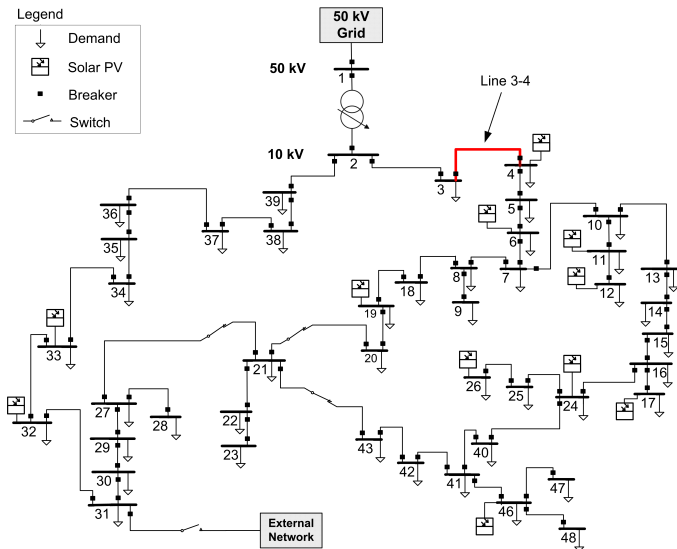

Fig. 5. Schematic of MV distribution case study network.

The AMI data acquisition rate is 1 hour, and all demand forecasts shown were made 24 hours ahead of time. Day-ahead forecasting is expected to be relevant for DSOs, since in many control centres, AMI data only becomes available to the operator on the next day [35]. Hence, the objective is to use the previous days' AMI data to predict and plan for network issues for the current day. The presented methodology could be modified to consider a different AMI acquisition rate (e.g. 15 minutes), or a different demand forecasting horizon by modifying the time delays in (2)-(3), Section III-A3. All of the presented analysis is carried out at the fundamental frequency (50 Hz). While the impacts from harmonic injections may be significant in networks with high DER penetrations, harmonic analysis is beyond the scope of this paper.

### B. Load and DG Forecasting Results

A sample of the typical results obtained using the NARX demand forecasting model are shown in Fig. 6, where the time series for 24 hour-ahead forecasting are compared at each time step to the subsequently recorded AMI values. Fig 6, gives a sample of the results where demand consumption and PV production are forecast separately and subtracted from each other ("Demand - PV"), and also the "Net demand" approach, using a the NARX model described in Section III-A3.

The results are compared in Table I at all nodes where embedded PV is installed, showing that a similar level of accuracy is obtained with both approaches, with the difference between in errors less than 1% at all buses. Using the combined "Net demand" NARX model simplifies the demand forecasting significantly, since it is not required to carry out separate forecasts for demand and PV. The average MAPE achieved across all MV/LV substations in the network for 24 hour-ahead forecasting was 8.27%.

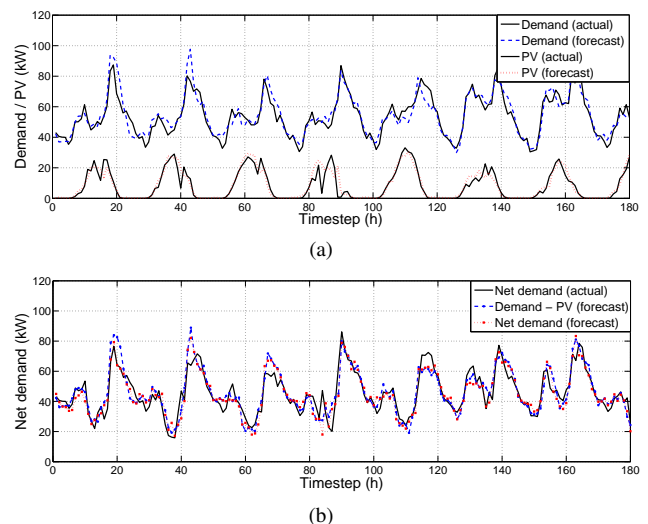

Fig. 6. Samples of time series of actual and forecasted demand and PV at individual substation (Bus 11): a) Separate forecasting of demand and PV production; b) Net demand forecasting.

TABLE I  
COMPARISON OF SEPARATE DEMAND AND PV FORECAST WITH NET DEMAND FORECAST RESULTS

Bus	Demand-PV (MAPE %)	Net demand (MAPE %)	Difference (%)
(4)	5.79	6.16	+ 0.37
(6)	7.12	6.85	- 0.27
(11)	7.71	7.78	+ 0.07
(12)	8.98	8.90	- 0.08
(14)	9.48	8.84	- 0.64
(17)	8.15	8.55	+ 0.40
(19)	7.30	7.42	+ 0.12
(24)	9.32	9.56	+ 0.24
(26)	10.16	10.93	+ 0.77
(32)	5.93	5.96	+ 0.03
(33)	10.86	10.80	- 0.06
(46)	8.47	8.50	+ 0.03

The daily and monthly variation of the net demand forecasting error (averaged across all substations in the network) is given in Fig. 7. These results show that forecasting errors are slightly higher during the peak hours from 07:00-10:00 in the morning and 16:00 to 20:00 in the evening (Fig. 7a). It is also clear that the demand forecasting errors are significantly higher during the summer months (Fig. 7a), which is expected, since at this time demands are low and PV output is high, making the resulting net demand difficult to predict with accuracy. These results have important implications for using the demand forecasts for forecasting the future states of the network, and implementing the distribution energy management services described in this paper. This higher level of uncertainty during certain time periods is incorporated in the analysis of voltage profiles presented in Section IV-D.

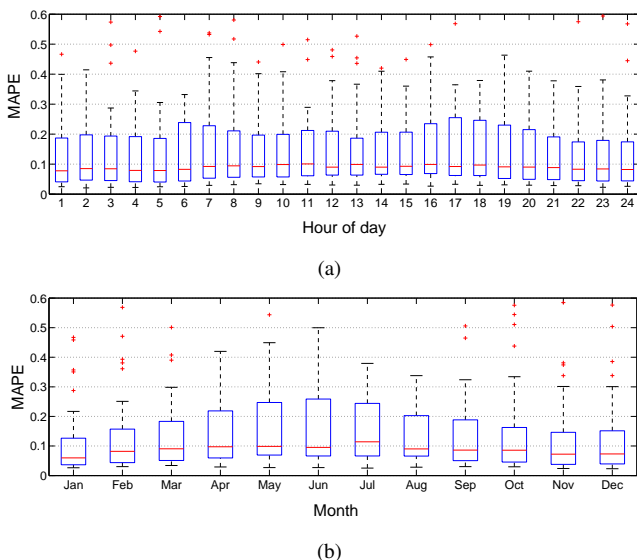

Fig. 7. Net demand forecasting error boxplots showing: a) hourly variation; b) monthly variation.

### C. Constraint Management using Distributed Energy Resources

This section demonstrates the approach for distribution system constraint management described in Section III-C using an example scenario applied to the case study MV network. A peak demand scenario is simulated, which results in a thermal overload constraint on Line 3-4 (highlighted in Fig. 5). It is assumed that there is some demand-response capability at each node in the distribution system, and that the system operator can apply this to resolve the system constraints, either by direct control of load/DER, or indirectly through end-users' response to a price signal. At each MV node, up to 10% of the total demand is manageable, e.g. can be deferred at the peak hour to enable constraint management.

Each bus in the network can be ranked according to its effectiveness in relieving the constraint according to (8). This ranking is shown for the first 10 buses in Table II, where the effectiveness  $E_{3-4}$  at each bus is compared to the network average effectiveness. As expected, buses located close to the

constraint and directly downstream are the most effective in relieving the constraint.

TABLE II  
BUS RANKINGS IN ORDER OF EFFECTIVENESS IN RELIEVING  
CONSTRAINT AT LINE 3-4

Bus	Rank	Effectiveness, $E_{3-4}$ (%)
(4)	1	111.51
(5)	2	110.03
(6)	3	109.64
(9)	4	109.18
(8)	5	109.18
(7)	6	108.10
(12)	7	108.00
(11)	8	107.94
(10)	9	107.70
(13)	10	106.83
(...)	...	...
<b>Network Average</b>	-	100.00

Two constraint management cases are investigated:

- **Case (i):** Demand response is applied at all nodes equally, reducing the load at all MV nodes in the network proportionally until the constraint is removed.
- **Case (ii):** The OPF formulation described by Equations (4)-(7) is used to find the optimal allocation of demand response resources required to remove the network constraints.

The total adjustment required in each case is given by:

$$P_{total} (kW) = \sum_{n=1}^{N_{loads}} P_{n,init} (1 - \Psi_n) \quad (11)$$

The results are given in Table III, where the fifth column shows the "Total adjustment required" in each case, calculated using (11). Case (ii) provides a more optimal solution, since the total load adjustment required to remove all of the network constraints is approximately 20% lower in this case.

TABLE III  
RESULTS OF CONSTRAINT MANAGEMENT USING DER

Case	MV nodes adjusted	Initial peak demand (kW)	Final adjusted demand (kW)	Total adjustment required (kW)
(i)	All	4578.9	4149.9	429.0
(ii)	4-20, 24-26	4578.9	4232.7	346.2

It is obvious to expect that load deferral in the nodes nearest the feeder where the constraint occurs will have a greater effect on removing the constraint violation, and that these should be prioritised in a demand-response action. The OPF formulation presented in Section III-C of this paper provides the network operator with a systematic method of quantifying the effect of implementing demand response at each node, and optimising the overall allocation. In the example shown, the approach is demonstrated using a thermal line constraint, but the methodology also includes voltage constraints (Equation



(5)), and could be easily extended to include other constraints, e.g. fault levels or stability limits. For simplicity, it is assumed in the analysis that the power factor of each MV load remains constant as load is disconnected. It is shown in [6] that this analysis can be extended by using more detailed, voltage-dependent models of the end-user loads, and to model the effects of demand-response on the network more accurately.

#### D. Voltage Estimation and Forecasting in LV networks

This section shows the results obtained for day-ahead estimation of LV network voltages. In Fig. 8, a schematic diagram of one of the LV feeders from the case study network is shown. Each of the LV nodes 3-6 has residential customers connected downstream, with a and the majority of users have PV capacity installed. The results of the probabilistic voltage estimation approach described in Section III-D are shown in Fig. 9 and Fig. 10, for a typical winter weekday and a typical summer weekday, respectively. Confidence intervals of 50%, 90%, and 99% are calculated according to (9)-(10).

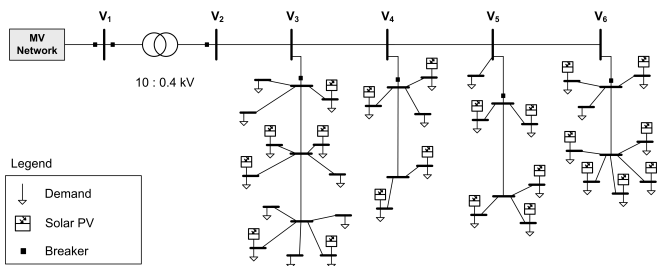

Fig. 8. Residential network used to demonstrate day-ahead voltage estimation at LV, showing locations of installed PV capacity in each load group.

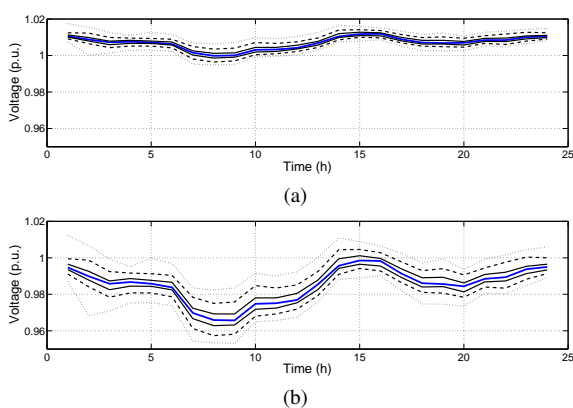

Fig. 9. Day ahead estimates voltage profiles on residential LV feeder for winter day, with confidence intervals at 50%, 90%, and 99%: a) LV node 3 ( $V_3$ ); b) LV node 6 ( $V_6$ ).

For the winter day case, the voltage there a significant drop in the voltage during the morning peak at 08:00-10:00 is forecasted. This effect is much more pronounced at the end of the feeder ( $V_6$ ) than at the node nearer to the feeder head,  $V_3$ . For the summer weekday case (Fig. 10), significant voltage rise is forecasted during the middle of the day (12:00-16:00), when demand is low and output from PV is high. The forecast uncertainty is particularly high during this time, Fig 10b.

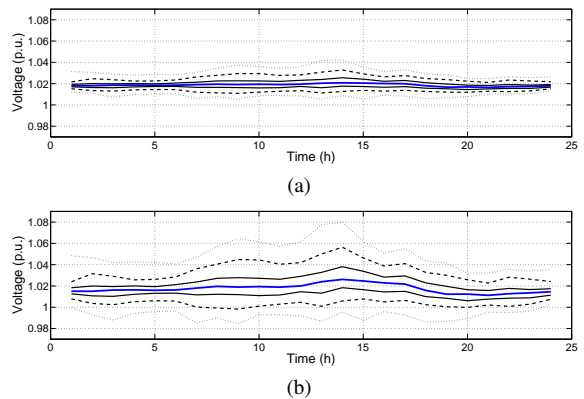

Fig. 10. Day ahead estimates voltage profiles on residential LV feeder for summer day, with confidence intervals at 50%, 90%, and 99%: a) LV node 3 ( $V_3$ ); b) LV node 6 ( $V_6$ ).

This approach can provide early warning of voltage issues and allow the network operator to avoid the occurrence of voltage excursions by adjusting control settings as discussed in Section III-D. In the example provided, it is assumed that the voltage setpoint at the on-load tap changing primary HV/MV transformer is 1.02 per unit. The MV/LV transformers have no on-load tap-changing capability, and there is no reactive compensation equipment installed in the part of the LV network considered. In networks which have capacitor banks or other voltage regulation installed, these elements should be included in the system model, along with their voltage control set points, in order to correctly forecast the voltage changes caused by their actions.

#### V. CONCLUSIONS

This paper described the application of AMI data to demand forecasting and operational planning services in distribution networks with significant DER. The main contributions are the development of three services, suitable for use in an advanced distribution network management system. These can be used to improve situational awareness and reduce network operator workload by automating a number of the tasks involved in short-term network planning. Each service is designed to function independent from the distribution network type and control scheme, and could be applied in either centralised or de-centralised energy management systems. Some conclusions on each individual service are provided below.

The demand forecasting service uses short-term load forecasting techniques to estimate demand and DG profiles at each MV substation in the distribution network. The availability of high-quality estimates at the MV substation level is important for short-term operational planning and situational awareness in the distribution network. However, the estimation of MV substation-level loads is a difficult problem, due to the inherent variability in smaller, disaggregated load profiles, and most of the available literature on short-term load forecasting is focused on the estimation of much larger demand groups (e.g. tens to hundreds of MWs). In this paper, a NARX model for forecasting of net demand at each distribution network substation was proposed, and it was demonstrated that it

provides a sufficient level of accuracy for the application. It uses both historical load data and local weather forecasts to estimate the demand, considering the impact on demands from embedded PV. The outputs of the load forecasting service can be applied for short-term planning, and are used as inputs to the other two services described in the paper. One of the limitations of the approach is that it only considers solar PV, and not other forms of DG, such as wind or dispatchable DG. However, solar PV is the most important DG technology in terms of its impact on substation-level demands in many current distribution networks, and is expected to be an important issue in the future. In the case of wind DG, this is typically installed in wind farms with larger overall capacities, rather than embedded at LV, and traditional wind power forecasting approaches should give better results than the “net demand” approach described here. In the case of dispatchable DG, this does not represent a forecasting problem as such, and its network impact can be estimated relatively easily once the rules around its scheduling and dispatch are known by the DSO.

A number of previous studies have examined the use of embedded DER and demand-responsive loads for the provision of energy balancing services and the improvement of system reliability. However, most of the work in this area does not consider the importance of the location of the energy resources within the distribution network on the effectiveness of such demand-response actions. This paper applies an OPF formulation to optimise the allocation of DER in managing network constraints. The example shown in Section IV-C demonstrates that the network location of DER has an important influence on the effectiveness of demand-response actions in relieving network constraints. It is demonstrated that the presented constraint management service provides a more optimal management of the available resources. The proposed OPF tool can be applied to any distribution system and any set of network constraints, and can also be used to calculate the maximum reserve available (e.g. for use in energy balancing or grid ancillary services) from all embedded DER within a distribution system.

Finally, the third service presented provides a means of forecasting voltage levels along LV feeders, where no direct voltage measurements are available. It is shown that the estimates of net demand obtained in Section III-A along with historical smart meter data, can be used to make a probabilistic estimate of the voltages in the LV networks. The approach is demonstrated in this paper using actual recordings from the case study network. It is shown that the approach provides early warning of potential voltage issues, and could be used as a basis for implementing control and optimisation schemes for management of voltage in LV networks with significant DER. Further work in this area will extend the LV voltage estimation and forecasting approach to incorporate three-phase LV network models and detailed, voltage-dependent load models in the analysis.

#### ACKNOWLEDGMENT

The authors kindly acknowledge the support of the European Commission projects on Marie Skłodowska-Curie re-

searcher mobility action (FP7-PEOPLE-2013-COFUND), the SmartHG research project (FP7-ICT- 2011-8, ICT-2011.6.1), and the Spanish Ministry of Economy and Competitiveness project RESmart (ENE2013-48690-C2-2-R).

#### REFERENCES

- [1] A. Keane, L. Ochoa, C. Borges, G. Ault, A. Alarcon-Rodriguez, R. Currie, F. Pilo, C. Dent, and G. Harrison, “State-of-the-art techniques and challenges ahead for distributed generation planning and optimization,” *IEEE Trans. Power Syst.*, vol. 28, no. 2, pp. 1493–1502, May 2013.
- [2] Y.-F. Huang, S. Werner, J. Huang, N. Kashyap, and V. Gupta, “State estimation in electric power grids: Meeting new challenges presented by the requirements of the future grid,” *Signal Processing Magazine, IEEE*, vol. 29, no. 5, pp. 33–43, 2012.
- [3] A. Meliopoulos, E. Polymeneas, Z. Tan, R. Huang, and D. Zhao, “Advanced distribution management system,” *IEEE Trans. Smart Grid*, vol. 4, no. 4, pp. 2109–2117, Dec 2013.
- [4] S. Grenard and O. Carre, “Optimal short term operational planning for distribution networks,” in *CIREC Electricity Distribution Workshop*, May 2012.
- [5] B. P. Hayes and M. Prodanovic, “Short-term operational planning and state estimation in power distribution networks,” in *CIREC Electricity Distribution Workshop*, June 2014, Rome, Italy.
- [6] B. P. Hayes, I. Hernando-Gil, A. Collin, G. P. Harrison, and S. Z. Djokic, “Optimal power flow for maximizing network benefits from demand-side management,” *IEEE Trans. Power Syst.*, vol. 29, no. 4, pp. 1739–1747, July 2014.
- [7] European Commission SmartHG project website. [Online]. Available: <http://smarthg.di.uniroma1.it/>
- [8] M. Zhao and A. Abur, “Multi area state estimation using synchronized phasor measurements,” *IEEE Trans. Power Syst.*, vol. 20, no. 2, pp. 611–617, May 2005.
- [9] M. Nordman and M. Lehtonen, “Distributed agent-based state estimation for electrical distribution networks,” *IEEE Trans. Power Syst.*, vol. 20, no. 2, pp. 652–658, May 2005.
- [10] A. Gómez-Expósito, A. de la Villa Jaén, C. Gómez-Quiles, P. Rousseaux, and T. V. Cutsem, “A taxonomy of multi-area state estimation methods,” *Electric Power Systems Research*, vol. 81, no. 4, pp. 1060 – 1069, 2011.
- [11] G. Korres, “A distributed multiarea state estimation,” *IEEE Trans. Power Syst.*, vol. 26, no. 1, pp. 73–84, Feb 2011.
- [12] L. Xie, D.-H. Choi, S. Kar, and H. Poor, “Fully distributed state estimation for wide-area monitoring systems,” *IEEE Trans. Smart Grid*, vol. 3, no. 3, pp. 1154–1169, Sept 2012.
- [13] H. Ma, Y.-H. Yang, Y. Chen, and K. Liu, “Distributed state estimation in smart grid with communication constraints,” in *2012 Asia-Pacific Signal Information Processing Association Annual Summit and Conference (APSIPA ASC)*, Dec 2012, pp. 1–4.
- [14] G. N. Korres, A. Tzavellas, and E. Galinas, “A distributed implementation of multi-area power system state estimation on a cluster of computers,” *Electric Power Systems Research*, vol. 102, no. 0, pp. 20 – 32, 2013.
- [15] D. Lubkeman, J. Zhang, A. Ghosh, and R. Jones, “Field results for a distribution circuit state estimator implementation,” *IEEE Trans. Power Delivery*, vol. 15, no. 1, pp. 399–406, Jan 2000.
- [16] I. Cobelo, A. Shafiu, N. Jenkins, and G. Strbac, “State estimation of networks with distributed generation,” *European Transactions on Electrical Power*, vol. 17, no. 1, pp. 21–36, 2007. [Online]. Available: <http://dx.doi.org/10.1002/etep.110>
- [17] R. Singh, B. Pal, and R. Jabr, “Choice of estimator for distribution system state estimation,” *Gen., Trans. Dist., IET*, vol. 3, no. 7, pp. 666–678, 2009.
- [18] R. Singh, B. Pal, and R. Vinter, “Measurement placement in distribution system state estimation,” *IEEE Trans. Power Syst.*, vol. 24, no. 2, pp. 668–675, 2009.
- [19] G. N. Korres, N. D. Hatzigiorgiou, and P. J. Katsikas, “State estimation in multi-microgrids,” *European Transactions on Electrical Power*, vol. 21, no. 2, pp. 1178–1199, 2011. [Online]. Available: <http://dx.doi.org/10.1002/etep.442>
- [20] W. Wu, Y. Ju, B. Zhang, and H. Sun, “A distribution system state estimator accommodating large number of ampere measurements,” *Int. Journal of Elec. Power & Energy Sys.*, vol. 43, no. 1, pp. 839 – 848, 2012.
- [21] B. P. Hayes, J. K. Gruber, and M. Prodanovic, “A closed-loop state estimation tool for MV network monitoring and operation,” *Smart Grid, IEEE Transactions on*, vol. 6, no. 4, pp. 2116–2125, July 2015.

- [22] D. Haughton and G. Heydt, "A linear state estimation formulation for smart distribution systems," *IEEE Trans. Power Syst.*, vol. 28, no. 2, pp. 1187–1195, May 2013.
- [23] I. Song, S.-Y. Yun, S. Kwon, and N. Kwak, "Design of smart distribution management system for obtaining real-time security analysis and predictive operation in Korea," *IEEE Trans. Smart Grid*, vol. 4, no. 1, pp. 375–382, March 2013.
- [24] S. Deshmukh, B. Natarajan, and A. Pahwa, "State estimation and Voltage/VAr control in distribution network with intermittent measurements," *IEEE Trans. Smart Grid*, vol. 5, no. 1, pp. 200–209, Jan 2014.
- [25] J. Mathieu, S. Koch, and D. Callaway, "State estimation and control of electric loads to manage real-time energy imbalance," *IEEE Trans. Power Syst.*, vol. 28, no. 1, pp. 430–440, Feb 2013.
- [26] A. Subramanian, M. Garcia, D. Callaway, K. Poolla, and P. Varaiya, "Real-time scheduling of distributed resources," *IEEE Trans. Smart Grid*, vol. 4, no. 4, pp. 2122–2130, Dec 2013.
- [27] M. Vlot, J. Knigge, and J. Slootweg, "Economical regulation power through load shifting with smart energy appliances," *IEEE Trans. Smart Grid*, vol. 4, no. 3, pp. 1705–1712, Sept 2013.
- [28] T. Mancini, F. Mari, I. Melatti, I. Salvo, E. Tronci, J. Gruber, B. Hayes, M. Prodanovic, and L. Elmegaard, "Demand-aware price policy synthesis and verification services for smart grids," in *IEEE International Conference on Smart Grid Communications (SmartGridComm)*, Nov 2014, pp. 794–799.
- [29] S. Villalba and C. Bel, "Hybrid demand model for load estimation and short term load forecasting in distribution electric systems," *IEEE Trans. Power Delivery*, vol. 15, no. 2, pp. 764–769, Apr 2000.
- [30] V. Miranda, J. Pereira, and J. Saraiva, "Load allocation in dms with a fuzzy state estimator," *IEEE Trans. Power Syst.*, vol. 15, no. 2, pp. 529–534, May 2000.
- [31] J. Wan and K. Miu, "Weighted least squares methods for load estimation in distribution networks," *IEEE Trans. Power Syst.*, vol. 18, no. 4, pp. 1338–1345, Nov 2003.
- [32] H. Wang and N. Schulz, "Using AMR data for load estimation for distribution system analysis," *Electric Power Systems Research*, vol. 76, no. 5, pp. 336 – 342, 2006.
- [33] W. Kersting and W. Phillips, "Load allocation based upon automatic meter readings," in *IEEE/PES Transmission and Distribution Conference and Exposition.*, April 2008, pp. 1–7.
- [34] R. Singh, B. Pal, and R. Jabr, "Distribution system state estimation through gaussian mixture model of the load as pseudo-measurement," *Gen., Trans. Dist., IET*, vol. 4, no. 1, pp. 50–59, Jan 2010.
- [35] K. Samarakoon, J. Wu, J. Ekanayake, and N. Jenkins, "Use of delayed smart meter measurements for distribution state estimation," in *Power and Energy Society General Meeting, 2011 IEEE*, July 2011, pp. 1–6.
- [36] A. T. Saric and A. Rankovic, "Load reallocation based algorithm for state estimation in distribution networks with distributed generators," *Electric Power Systems Research*, vol. 84, no. 1, pp. 72 – 82, 2012.
- [37] E. Manitsas, R. Singh, B. Pal, and G. Strbac, "Distribution system state estimation using an artificial neural network approach for pseudo measurement modeling," *IEEE Trans. Power Syst.*, vol. 27, no. 4, pp. 1888–1896, Nov 2012.
- [38] J. Wu, Y. He, and N. Jenkins, "A robust state estimator for medium voltage distribution networks," *IEEE Trans. Power Syst.*, vol. 28, no. 2, pp. 1008–1016, May 2013.
- [39] M. Baran and T. McDermott, "Distribution system state estimation using AMI data," in *IEEE/PES Power Systems Conference & Exposition*, March 2009, pp. 1–3.
- [40] R. F. Arritt, R. Dugan, R. Uluski, and T. Weaver, "Investigation load estimation methods with the use of AMI metering for distribution system analysis," in *IEEE Rural Electric Power Conference (REPC)*, April 2012, pp. B3–1–B3–9.
- [41] S. Alam, B. Natarajan, and A. Pahwa, "Distribution grid state estimation from compressed measurements," *IEEE Trans. Smart Grid*, vol. 5, no. 4, pp. 1631–1642, July 2014.
- [42] B. P. Hayes, J. K. Gruber, and M. Prodanovic, "Short-term load forecasting at the local level using smart meter data," in *PowerTech, 2015 IEEE Eindhoven*, June 2015, pp. 1–6.
- [43] T. Hong, "Short term electric load forecasting," Ph.D. dissertation, North Carolina State University, 2010.
- [44] G. Gross and F. Galiana, "Short-term load forecasting," *Proceedings of the IEEE*, vol. 75, no. 12, pp. 1558–1573, Dec 1987.
- [45] H. Hippert, C. Pedreira, and R. Souza, "Neural networks for short-term load forecasting: a review and evaluation," *IEEE Trans. Power Syst.*, vol. 16, no. 1, pp. 44–55, Feb 2001.
- [46] J. Taylor and P. McSharry, "Short-term load forecasting methods: An evaluation based on european data," *IEEE Trans. Power Syst.*, vol. 22, no. 4, pp. 2213–2219, Nov 2007.
- [47] Danish Meteorological Institute. Online. [Online]. Available: <http://www.dmi.dk/en/vejlr/>
- [48] Y. Goude, R. Nedellec, and N. Kong, "Local short and middle term electricity load forecasting with semi-parametric additive models," *IEEE Trans. Smart Grid*, vol. 5, no. 1, pp. 440–446, Jan 2014.
- [49] M. Espinoza, J. Suykens, R. Belmans, and B. De Moor, "Electric load forecasting," *Control Systems, IEEE*, vol. 27, no. 5, pp. 43–57, Oct 2007.
- [50] L. Fink and K. Carlsen, "Power/energy: Operating under stress and strain," *Spectrum, IEEE*, vol. 15, no. 3, pp. 48–53, March 1978.
- [51] P. Mallet, P.-O. Granstrom, P. Hallberg, G. Lorenz, and P. Mandatova, "Power to the people: European perspectives on the future of electric distribution," *Power and Energy Magazine, IEEE*, vol. 12, no. 2, pp. 51–64, March 2014.
- [52] I. Hernando-Gil, B. P. Hayes, A. Collin, and S. Z. Djokic, "Distribution network equivalents for reliability analysis: Part 2," in *IEEE Innovative Smart Grid Technologies Europe Conf.*, Oct 2013, pp. 1–5.
- [53] I.-S. Ilie, I. Hernando-Gil, and S. Z. Djokic, "Risk assessment of interruption times affecting domestic and non-domestic electricity customers," *Int. Journal of Elec. Power & Energy Sys.*, vol. 55, pp. 59 – 65, 2014.



**Barry P. Hayes** (S'09, M'12) received the B. Eng. degree in electrical engineering from University College Cork, Cork, Ireland in 2005, the M. Eng. from the National University of Ireland, Maynooth, Ireland in 2008, and the Ph.D degree from the University of Edinburgh, Edinburgh, UK in 2013. He has also worked as a research fellow at the University of Edinburgh, and in industry with Intel Ireland and National Grid UK. He is currently a Marie Curie postdoctoral research fellow at Institute IMDEA Energy in Madrid, Spain. His research

interests include the network integration of renewable energy sources, and the operation and planning of future power systems.



**Milan Prodanovic** (M01) received the B.Sc. degree in electrical engineering from the University of Belgrade, Belgrade, Serbia, in 1996 and the Ph.D degree from Imperial College, London, UK, in 2004. From 1997 to 1999 he was engaged with GVS engineering company, Serbia, developing UPS systems. From 1999 until 2010 he was a research associate in Electrical and Electronic Engineering at Imperial College, London, UK. Currently he is a Senior Researcher and Head of the Electrical Systems Unit at Institute IMDEA Energy, Madrid, Spain. His research interests include design and control of power electronics

interfaces for distributed generation and management of active distribution networks and micro-grids.