

Sains Malaysiana 43(8)(2014): 1263–1269

Linear-Time Heuristic Partitioning Technique for Mapping of Connected Graphs into Single-Row Networks

(Teknik Pemetakan Heuristik Masa-Linear untuk Pemetaan Graf Berkait kepada Rangkaian Baris Tunggal)

SER LEE LOH, SHAHARUDDIN SALLEH & NOR HANIZA SARMIN*

ABSTRACT

In this paper, a model called graph partitioning and transformation model (GPTM) which transforms a connected graph into a single-row network is introduced. The transformation is necessary in applications such as in the assignment of telephone channels to caller-receiver pairs roaming in cells in a cellular network on real-time basis. A connected graph is then transformed into its corresponding single-row network for assigning the channels to the caller-receiver pairs. The GPTM starts with the linear-time heuristic graph partitioning to produce two subgraphs with higher densities. The optimal labeling for nodes are then formed based on the simulated annealing technique. Experimental results support our hypothesis that GPTM efficiently transforms the connected graph into its single-row network.

Keywords: Connected graph; graph partitioning; single-row; transformation

ABSTRAK

Dalam kertas kajian ini, suatu model yang dinamakan model pembahagian graf dan transformasi (GPTM) yang mengubah suatu graf berkait kepada rangkaian baris tunggal diperkenalkan. Transformasi tersebut diperlukan dalam aplikasi seperti penugasan saluran telefon kepada pasangan pemanggil-penerima merayau dalam sel dalam rangkaian selular atas asas masa sebenar. Suatu graf berkait kemudiannya diubah kepada rangkaian baris tunggal yang sepadan untuk pengalihan saluran kepada pasangan pemanggil dan penerima. GPTM bermula dengan pembahagian graf kepada dua subgraf berketumpatan lebih tinggi. Pelabelan optimum untuk nod kemudiannya dibentuk berdasarkan teknik simulasi penyepuhlindapan. Hasil uji kaji menyokong hipotesis ini bahawa GPTM mengubah graf berkait kepada rangkaian baris tunggal dengan cekap.

Kata kunci: Baris tunggal; graf berkait; pembahagian graf; transformasi

INTRODUCTION

Many engineering and science problems can be represented as a problem in graph theory. The graph represents the scenario of the real-life applications where the nodes in the graph can be treated as nodes in a network and the edges represent the communication links between the nodes. In this paper, the graph is transformed into a single-row network.

The single-row routing problem has been shown to be an NP-complete problem by Ting et al. (1976). The optimum solution is not easy to determine. For this reason, Kuh et al. (1979) developed the necessary and sufficient conditions for an optimum single-row routing problem base on the work of Ting et al. (1976). A partitioning strategy was proposed by Tarnig et al. (1984) to group the nets into zones which produced reasonably good solutions for some restricted models. Bhattacharya et al. (1988) proposed a new approach based on a graph-theoretic representation in which they relate the intervals of the single-row network with the overlap and interval graphs to solve the single-row routing problem.

Figure 1 shows a realization in a single-row routing from the ordering list $L = \{N_1, N_2, N_5, N_4, N_2\}$. Physically, each net in the single row represents a conductor path for

its terminals to communicate. The area above the single-row axis is called the *upper street*, while the below is the *lower street*. The number of horizontal tracks in the upper and lower streets is called the *upper street congestion* Q_u and the *lower street congestion* Q_l , respectively. The overall street congestion Q of a realization is defined as the maximum of its upper and lower street congestions, that is, $Q = \max(Q_u, Q_l) = 3$ in the above figure. A crossing on the node axis, as shown through a line between nodes 4 and 5 in the figure, is called a *dogleg* or interstreet crossing. The realization also produces two doglegs in this example. (Salleh et al. 2007, 2005)

A model called enhanced simulated annealing technique for single-row routing (ESSR) was proposed by Salleh et al. (2002) to optimize the network by minimizing both the congestion and the number of doglegs. When the total energy value is minimized, congestion and number of doglegs are minimized as well. Based on the simulated annealing technique from Kirkpatrick et al. (1983), the energy function in ESSR is a function of the height of the segments of the nets in the single-row network. This technique has been successfully applied to produce optimal solutions to all net sizes.

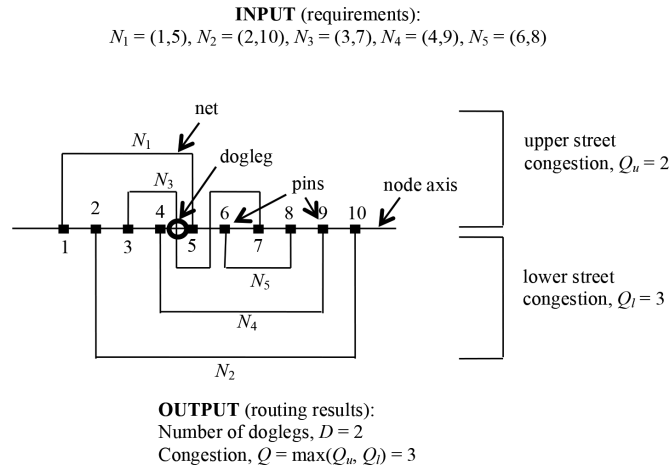

FIGURE 1. Terminologies in the single-row routing problem

The relation between a complete graph and its single-row representation was formulated for the first time (Salleh et al. 2007, 2005). Both models were equipped with the technique of transforming a graph into a single-row network where ESSR (Salleh et al. 2002) is applied to produce optimal results.

Our present work focuses on a connected graph. In our previous work, a model called double simulated annealing (DSA) has been introduced to transform an arbitrary connected graph into a single-row network (Loh et al. 2008). DSA is the very first model which tackles the optimality of sequence of zones by permuted the position of zones using simulated annealing. In order to deal with a graph in general as different graphs have different properties, some models where each transforms a specific type of graph have been developed, such as perfect binary trees, trees, sparse graphs and connected graph with a number of clusters (Loh et al. 2014, 2012, 2011, 2010). As the order and the size of graph increase, graph partitioning is able to improve the results since it divides the graph based on the structure and the connection of the graph. A systematic arrangement given by graph partitioning leads towards better solutions.

In this paper, a model called graph partitioning and transformation model (GPTM) is introduced which performs single-row transformation through two steps. The graph is first partitioned into two subgraphs with higher densities. The zones which correspond to the nodes in each of the subgraphs are then formed based on the simulated

annealing technique to obtain the labeling for nodes. This model is followed by ESSR to produce an optimal single-row network.

PROBLEM STATEMENT

The transformation problem can be stated as follows:

How can a given connected graph G be optimally transformed into a single-row network S by graph partitioning so as to minimize the congestion and number of doglegs in the network?

The problem is illustrated in Figure 2. The figure shows a connected graph with the order $n = 10$ and its single-row network S . In the single-row transformation, a node v_i in G is mapped onto d_i terminals in S where d_i is the degree of the node v_i for $i = 1, 2, \dots, n$.

In order to achieve optimality in S , the zones from each subgraph are arranged as a group in a single-row. For example, the graph G from Figure 2 can be partitioned into two subgraphs; first with nodes numbered one to five and second with nodes numbered six to ten with a graph density of 0.8 and 0.6, respectively, compared to 0.36 given by graph G . The zones correspond to the nodes in a subgraph are then arranged by simulated annealing as a group of zones in S to reduce the congestion and doglegs caused by nets from different subgroup of zones. This is followed by ESSR for the optimal single-row network.

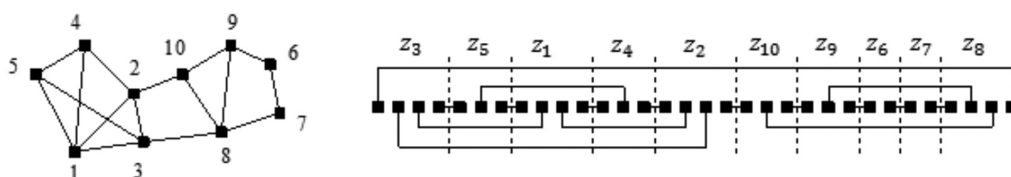

FIGURE 2. Connected graph G (left) and its mapping into the single-row network S (right)

GPTM: THE TRANSFORMATION MODEL

There are two main steps in the graph partitioning and transformation model (GPTM), namely, the linear-time heuristic graph partitioning to obtain two higher densities of subgraphs, and the formation of zones within each of the subgraphs. The schematic flow of GPTM is shown in Figure 3.

LINEAR-TIME HEURISTIC FOR GRAPH PARTITIONING

In 1970, Kernighan and Lin introduced a graph partitioning technique with a complexity of $O(n^2)$. Twelve years later, a linear-time heuristic in improving the network partitions was presented by Fiduccia and Mattheyses (1982) where one pass of an iterative min-cut heuristic for graph partitioning grows linearly with the size of the network. The advantages are avoiding unnecessary best node searching and the updating of nodes by each move. The minimization algorithm of the scheme requires $O(P)$ time to complete one pass where P is the total number of terminals.

These ideas are applied in graph partitioning in GPTM. The aim of graph partitioning is to divide the graph into two subgraphs in such a way that the total interlinks are minimized.

Given a connected graph with n nodes consisting of m edges. Each node v_i has d_i degree or pins for $i = 1, 2, \dots, n$. The structure of data involved a pair of nodes and its corresponding pin arrays from the sequence of edges given as the input. Initially, the n nodes are randomly divided into two partitions with a balance order followed by the determination of total interlinks $Inter_i$ and intralinks $Intra_i$ every node. Each node in the partitions has a measurement called Gain G_i to show the decreasing of number of interlinks when the node v_i is moved from its current partition to another partition.

Gain G_i is computed from the difference between the total interlinks and total intralinks of v_i . The G_i is sorted in a list using an array, whose k^{th} entry contains a doubly-linked

list of free nodes with gains currently equal to k . Each of the partition needs such an array which is maintained by moving the node to an appropriate bucket whenever its gain is changed due to the movement of any of its neighbors. A bucket array is an array whose k^{th} entry contains a doubly-linked list of free nodes with $G_i = k$.

In order to reduce the total number of interlinks, the node with the highest gain is chosen based on the balance criterion and moved from its current partition to another new partition. The balance criterion used is Partition A and B, taking turns to allow a node to be moved alternately from one to another. Balance criterion is used to avoid the transferring of all nodes to one partition. Once a node is moved, the node is locked in its new partition to avoid an infinite loop in a pass until all of the nodes are locked or the balancing criterion prevents further moves. All nodes are then unlocked for the next pass since additional passes may be needed to improve the result until no further improvements are needed. The algorithm of linear-time heuristic for graph partitioning for a pass is outlined in Algorithm 1.

Algorithm 1: Linear-time heuristic graph partitioning

Divides V into two partitions;

for $i = 1$ **to** n

 Compute $inter_i$, $intra_i$ and G_i ;

endfor;

for $i = 1$ **to** 2 // Partition A = 1, Partition B = 2

 Sort the G_i into a sorted list (a BUCKET array whose k^{th} entry contains a doubly-linked list of free nodes with $G_i = k$);

endfor;

for $i = 1$ **to** n

for $j = 1$ **to** n

if j is odd

if $max_gain_1 > max_gain_2 > 0$ and free nodes exist in A

 Set $r = 1$; $s = 2$;

else if $max_gain_2 > max_gain_1 > 0$ and free nodes exist in B

 Set $r = 2$; $s = 1$;

else

 break;

endif;

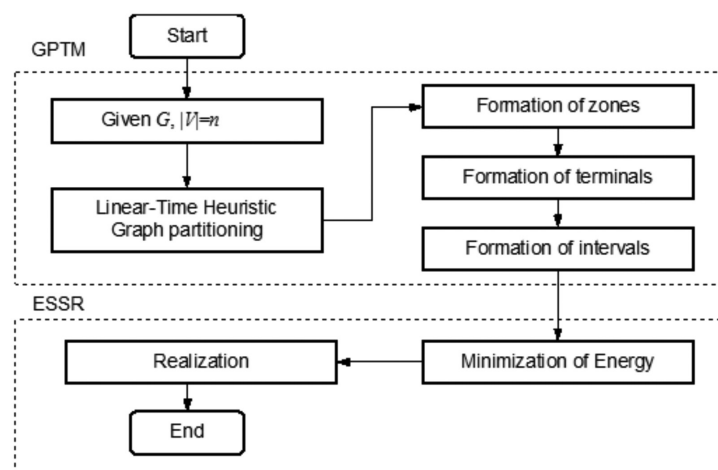

FIGURE 3. The schematic flow of GPTM

```

    Move the node with  $max_{gain_r}$  from partition  $r$  to  $s$ ;
else
    Move the node with  $max_{gain_s}$  from partition  $s$  to  $r$ ;
endif;
Update  $G_i$  list and lock the moved node;
endfor;
if result is improved
    Unlock all nodes;
else
    break;
endif;
endfor;

```

```

endif;
endfor;
Update  $T_{w+1} \leftarrow \alpha T_w$ ;
if  $T_{w+1} < \epsilon$ 
    break;
endif;
endfor;
endfor;

Select one pair of zones in  $k^{th}$  partition and swap their
order to form  $c_r$ ;
Formation of intervals; // (Loh et al., 2012)
Evaluate the new energy  $E_r$  and congestion  $Q_r$ ;
if  $Q_r \leq Q_w$ 
    if  $(\Delta E = E_r - E_w \leq 0)$  or if  $(\Delta E > 0$  and  $\exp(-|\Delta E|/T_w) > \epsilon)$ 
        Update  $c_w \leftarrow c_r$ ,  $E_w \leftarrow E_r$  and  $Q_w \leftarrow Q_r$ ;
        break;
    endif;
endif;
endfor;
Update  $T_{w+1} \leftarrow \alpha T_w$ ;
if  $T_{w+1} < \epsilon$ 
    break;
endif;
endfor;
endfor;

```

FORMATION OF ZONES, TERMINALS AND

INTERVALS FOR GPTM

The formation of zones represents the mapping from vertices in into zones in. Every in has a number of terminals equaling to its number of degree of vertex in. Hence, the total of terminals formed from to are aligned on a node axis. In the single-row transformation, the nodes in a partition or a subgraph are transformed into a group of zones on the node axis as shown in Figure 4. In each group of zones, the initial solutions for the sequence of zones are randomly done. The sequences of zones in both groups are permuted individually using simulated annealing to improve the results.

The heuristic approach formation of zones is outlined in Algorithm 2. In each group of zones, the initial solutions for the sequence of zones are randomly done. The sequences of zones in both groups are permuted individually using simulated annealing to improve the results.

After the formation of zones, terminals for the zones are formed where each zone has terminals. All terminals are aligned on the node axis and numbered successively based on the sequence of zones. The terminals are then joined by the intervals (Loh et al. 2012).

Once the nets construction process is completed, the nets are renumbered from their beginning terminals in ascending order. This step is followed by the assignment of each net to a unique level which represents the order of nets. The final step is applying ESSR (Salleh et al. 2002) to obtain the optimal sequence for the order of nets to produce a single-row network with the least congestion.

```

Select one pair of zones in  $k^{th}$  partition and swap their
order to form  $c_r$ ;
Formation of intervals; // (Loh et al., 2012)
Evaluate the new energy  $E_r$  and congestion  $Q_r$ ;
if  $Q_r \leq Q_w$ 
    if  $(\Delta E = E_r - E_w \leq 0)$  or if  $(\Delta E > 0$  and  $\exp(-|\Delta E|/T_w) > \epsilon)$ 
        Update  $c_w \leftarrow c_r$ ,  $E_w \leftarrow E_r$  and  $Q_w \leftarrow Q_r$ ;
        break;
    endif;
endif;

```

EXPERIMENTAL RESULTS AND DISCUSSION

A program has been developed based on the GPTM model using Microsoft Visual C++ 6.0. GPTM is applied on connected graphs with different orders and graph densities. The graphs are partitioned into two subgraphs, each with a higher density value than the graph.

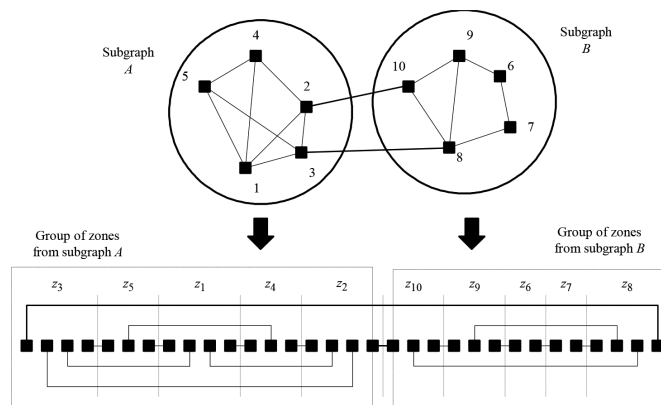

FIGURE 4. Transformation of nodes in subgraphs into groups of zones

The graphs with order $n = 10$ to 30 represent the small, medium and large data. A complete graph with n nodes has $m = \frac{n(n-1)}{2}$ number of edges with a unit of density. Hence, the density of graph is computed by the formula $Density = \frac{2m}{n(n-1)}$. As the order of a graph increases, the lowest density of the graph decreases. Hence, the lowest density that a graph with 10 nodes can have is 0.2 unit.

The transformation result is depending very much on the sequence of zones. However, the sequence of zones has no effect to complete graphs since each of the nodes are adjacent to each other. Hence, a high density graph (density of 0.7 and above) may be solved without any partitioning technique.

The simulations are run and compared with the DSA model. The results in terms of energy values (E), congestion (Q) and number of doglegs (D) are summarized in Table 1.

From Table 1, it is clear that the energy values are proportionally related to the order and density of the graph for both methods. GPTM gives an energy value of six compared to one unit from DSA for a graph order of ten nodes with the lowest density value. The results from both methods are the same for the density of graph 0.3

which is seven units. GPTM then gives the result with five units more for density of graph 0.4 before it can beat DSA with one unit less in the next density of graph. When the density increases to 0.6 and 0.8, GPTM gives 86 and 219 units of energy, respectively, while DSA gives 69 and 211 units of energy, respectively.

As the order of graph increases to 20 nodes, GPTM produces six units more energy than DSA which gives only two units of energy. Since then, GPTM produced better results than DSA by presenting 49, 213, 495, 1099, 2594 and 8724 units of energy which are 4, 70, 107, 228, 993 and 31 units less than DSA at a density of 0.2, 0.3, 0.4, 0.5, 0.6 and 0.8, respectively.

GPTM improves the results of DSA as the order of the graph increases to 30 nodes. By showing six more units than DSA at a density of 0.1, GPTM improves the results of DSA by the amount of 166, 252, 881, 2117, 5654 and 2869 each at densities of 0.2, 0.3, 0.4, 0.5, 0.6 and 0.8, respectively.

With the high density of 0.8, GPTM slightly improve the result compared to DSA in terms of congestion. This is due to the nodes labeling, which corresponds to the sequence of zones, of a massively dense graph has no significant affection to the result. Hence, the results for each order and

TABLE 1. Results of single-row transformation for some graphs 10 to 30 with densities 0.1 to 0.8 by GPTM and DSA

Num.	Order of G, n	Density of graph, $Density$	Size of G, m	Results					
				GPTM			DSA		
				E	Q	D	E	Q	D
1	10	0.2	9	6	2	0	1	1	0
2	10	0.3	14	7	2	0	7	2	0
3	10	0.4	18	19	4	0	14	3	0
4	10	0.5	23	31	4	4	32	5	4
5	10	0.6	27	86	7	13	69	6	12
6	10	0.8	36	219	12	32	211	12	36
7	20	0.1	19	8	2	1	2	1	0
8	20	0.2	38	49	4	6	53	5	4
9	20	0.3	57	213	9	42	283	15	42
10	20	0.4	76	495	15	86	602	15	107
11	20	0.5	95	1099	18	180	1327	26	200
12	20	0.6	114	2594	26	322	3587	31	432
13	20	0.8	152	8724	52	734	8755	55	735
14	30	0.1	44	48	5	4	42	5	3
15	30	0.2	87	342	11	60	508	14	98
16	30	0.3	131	2097	30	305	2349	35	321
17	30	0.4	174	4792	44	541	5673	50	562
18	30	0.5	218	7230	45	720	9347	48	818
19	30	0.6	261	15251	47	1497	20905	56	1686
20	30	0.8	305	93997	106	4035	96866	107	4070

density of graphs (0.1 - 0.6) from two different methods are further compared by presenting Figure 5(a), 5(b) and 5(c) accordingly.

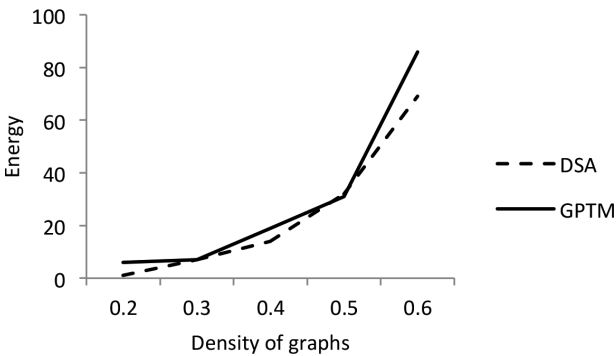

FIGURE 5(a). Results of Single-Row Transformation for DSA and GPTM when $n = 10$ with densities 0.2 to 0.6

Figure 5(a) shows that GPTM gives a slightly higher energy value than DSA for graphs with order $n=10$ under different densities of graph varying from 0.2 to 0.6. The heuristic method of simulated annealing works efficiently especially for the smaller order of graph. When the order of graph is as small as $n=10$ and GPTM divides the graph into two subgraphs each with five nodes, it leads to the restriction on the permutation of zones from different groups which results to the loss of credit for the best results.

Figure 5(b) and 5(c) show that the difference between energy values of GPTM and DSA is become larger as the order and density of the graph increase. The DSA and GPTM applied simulated annealing twice in forming the zones and intervals. The sequence of zones is improved by changing a pair of nodes in each of the iteration using simulated annealing. The permutation of zones is crucial for a graph with higher density.

Compared with DSA, GPTM produces better results as the order and density of graph increase. GPTM divides a connected graph into two higher densities of subgraphs which are connected by minimum interlinks. This reduces

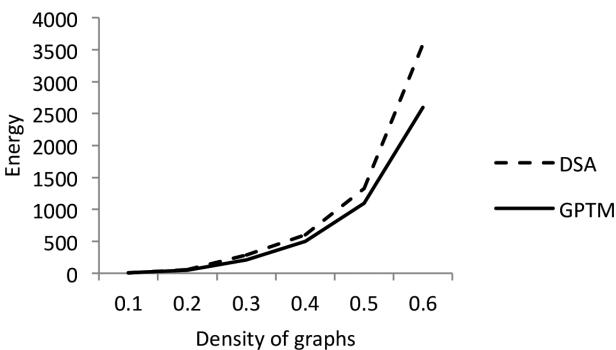

FIGURE 5(b). Results of Single-Row Transformation for DSA and GPTM when $n = 30$ with densities 0.1 to 0.6

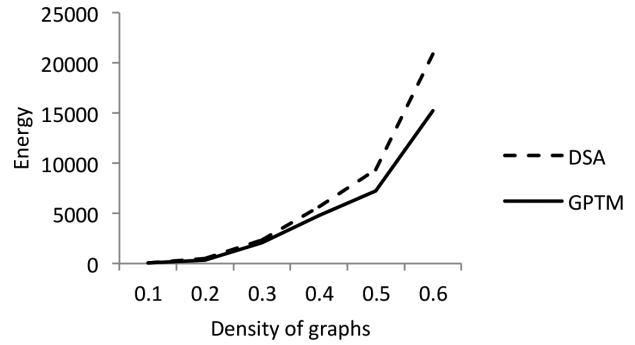

FIGURE 5(c). Results of Single-Row Transformation for DSA and GPTM when $n = 30$ with densities 0.1 to 0.6

the nets constructed across two groups of zones and the degree of permutation of zones. In addition, simulated annealing is more effective for the lower order of graphs. Hence, GPTM successfully improves the results of DSA as the order of graph increases.

CONCLUSION

In this paper, a new technique for transforming a connected graph into a single-row network has been developed namely graph partitioning and transformation model (GPTM). This model consists of two steps, namely, the graph partitioning and the formation of zones.

The given connected graph is divided into two subgraphs, each with a higher density of graph G compared to the connected graph by a linear-time heuristic of graph partitioning. The zones corresponding to the nodes in each of the subgraphs are mapped into groups of zones on node axis by the formation of zones. It is followed by the formation of intervals or nets in the single-row network. The simulation model, called ESSR is then applied to the intervals to produce an optimal single-row network by minimizing the energy.

GPTM has been tested using some different models of connected graphs with orders ranging from 10 to 30 nodes and densities varying from 0.1 to 0.6. The DSA model has been applied to the same cases to compare the simulation results from GPTM. The simulations show GPTM is outstanding in terms of results as the order and density of the graph increase.

ACKNOWLEDGEMENTS

The authors would like to thank the Ministry of Education (MOE), Malaysia and Universiti Teknologi Malaysia for the financial assistance through FRGS grant with Vote No. 4F010.

REFERENCES

Bhattacharya, B.B., Deogun, J.S. & Sherwani, N.A. 1988. A graph theoretic approach to single row routing problems. In *Proceedings of the 1988 IEEE International Symposium on Circuit and Systems 2*: 1437-1440.

- Fiduccia, C.M. & Mattheyses, R.M. 1982. A linear-time heuristic for improving network partitions. In *Proc. 19th ACM/IEEE Design Automation Conference* 175-181.
- Kernighan, B.W. & Lin, S. 1970. An efficient heuristic procedure for partitioning graphs. *Bell Sys. Tech. J.* 49: 291-308.
- Kirkpatrick, S., Gelatt, C.D. & Vecchi, M.P. 1983. Optimization by simulated annealing. *Science* 220(4598): 671-678.
- Kuh, E.S., Kashiwabara, T. & Fujisawa, T. 1979. On optimum single-row routing. *IEEE Transactions Circuit and Systems* 26(6): 361-368.
- Loh, S.L., Salleh, S. & Sarmin, N.H. 2014. An extended partitioning technique to transform trees into single-row networks. *Applied Soft Computing* 22: 483-491.
- Loh, S.L., Salleh, S. & Sarmin, N.H. 2012. Partitioning technique for transforming perfect binary trees into single-row networks. *Japan Journal of Industrial and Applied Mathematics* 29(2): 317-330.
- Loh, S.L., Salleh, S. & Sarmin, N.H. 2011. Partitioning technique for transformation of connected graphs into single-row networks. *Jurnal Teknologi* 55 (Sains & Kej.) Special Issue (1): 241-253.
- Loh, S.L., Salleh, S. & Sarmin, N.H. 2010. Spanning tree transformation of connected graph into single-row network. In *Proceedings of International Conference on Computational and Mathematical Engineering*. Bayview Hotel Georgetown, Penang, Malaysia. 24 - 25 February. pp. 597-601.
- Loh, S.L., Salleh, S. & Sarmin, N.H. 2008. Double simulated annealing model for mapping of graphs to single-row networks. In *Advances in Fundamentals and Social Sciences*. Johor: Penerbit Universiti Teknologi Malaysia. pp. 51-64.
- Salleh, S., Olariu, S. & Sanugi, B. 2005. Single-row transformation of complete graphs. *Journal of Supercomputing* 31: 265-279.
- Salleh, S., Olariu, S., Zomaya, A.Y., Kiew, L.Y. & Aziz, N.A.B. 2007. Single-row mapping and transformation of connected graphs. *Journal of Supercomputing* 39: 73-89.
- Salleh, S., Sanugi, B., Jamaludin, H., Olariu, S. & Zomaya, A.Y. 2002. Enhanced simulated annealing technique for the single-row routing problem. *Journal of Supercomputing* 21(3): 285-302.
- Tarnag, T.T., Sadowska, M.M. & Kuh, E.S. 1984. An efficient single-row algorithm. *IEEE Transactions on Computer-Aided Design* 3(3): 178-183.
- Ting, B.S., Kuh, E.S. & Shirakawa, L. 1976. The multilayer routing problem: Algorithms and necessary and sufficient conditions for the single row, single layer case. *IEEE Transactions Circuit and Systems* 23:768-778.

Ser Lee Loh
 Department of Industrial Power
 Faculty of Electrical Engineering
 Universiti Teknikal Malaysia Melaka
 76100 Durian Tunggal, Melaka
 Malaysia

Shaharuddin Salleh
 Center for Industrial and Applied Mathematics
 Universiti Teknologi Malaysia
 81310 Johor Bahru, Johor
 Malaysia

Nor Haniza Sarmin*
 Department of Mathematical Sciences
 Universiti Teknologi Malaysia
 81310 Johor Bahru, Johor
 Malaysia

*Corresponding author; email: nhs@utm.my

Received: 13 November 2011
 Accepted: 18 November 2013