

BiSON

Birmingham
Solar-Oscillations
Network

TECHNICAL REPORT NO. 372

The Hannibal Temperature Controllers

Steven J. Hale

The University of Birmingham, Edgbaston, Birmingham B15 2TT

2015 May 8

This technical report series is published by:



**THE UNIVERSITY
OF BIRMINGHAM**

High-Resolution Optical-Spectroscopy Group

School of Physics and Astronomy
The University of Birmingham
Edgbaston, Birmingham B15 2TT, United Kingdom
Telephone: +44-121-414-4551 FAX: +44-121-414-4601

The Hannibal Temperature Controllers

Steven J. Hale

The University of Birmingham, Edgbaston, Birmingham B15 2TT

2015 May 8

Abstract

A temperature controller for Hannibal in Las Campanas.

Contents

1	Introduction	1
2	External Configuration	2
3	Internal Configuration	6
4	Firmware	9

1 Introduction

This report describes the configuration of the temperature controller for Hannibal installed in Las Campanas. It uses a version of the temperature controllers known as “5generic_v4”. It contains main board TC-MAIN-4 where all five input channels can be configured for AD590s, LM35s, or pure voltages, and two drive boards TC-DRIVE-5.

For full documentation please see BTR335 [1]. This report details only the configuration items specific to Hannibal in Las Campanas.

2 External Configuration

2.1 Temperature Input

The Las Campanas temperature monitor (which is the same as the Carnarvon temperature monitor [2]) was installed along with the Zoo in 2006 February [3]. In order to install the new temperature controller, some of the temperature channels had to be moved away from the monitor. This involved making two new “we” cables shown in figures 1 and 2.

The “Temperature A” we cable splits out two temperatures to the monitor, and two to the controller. The “Temperature B” we cable splits out the remaining three temperatures to the controller.

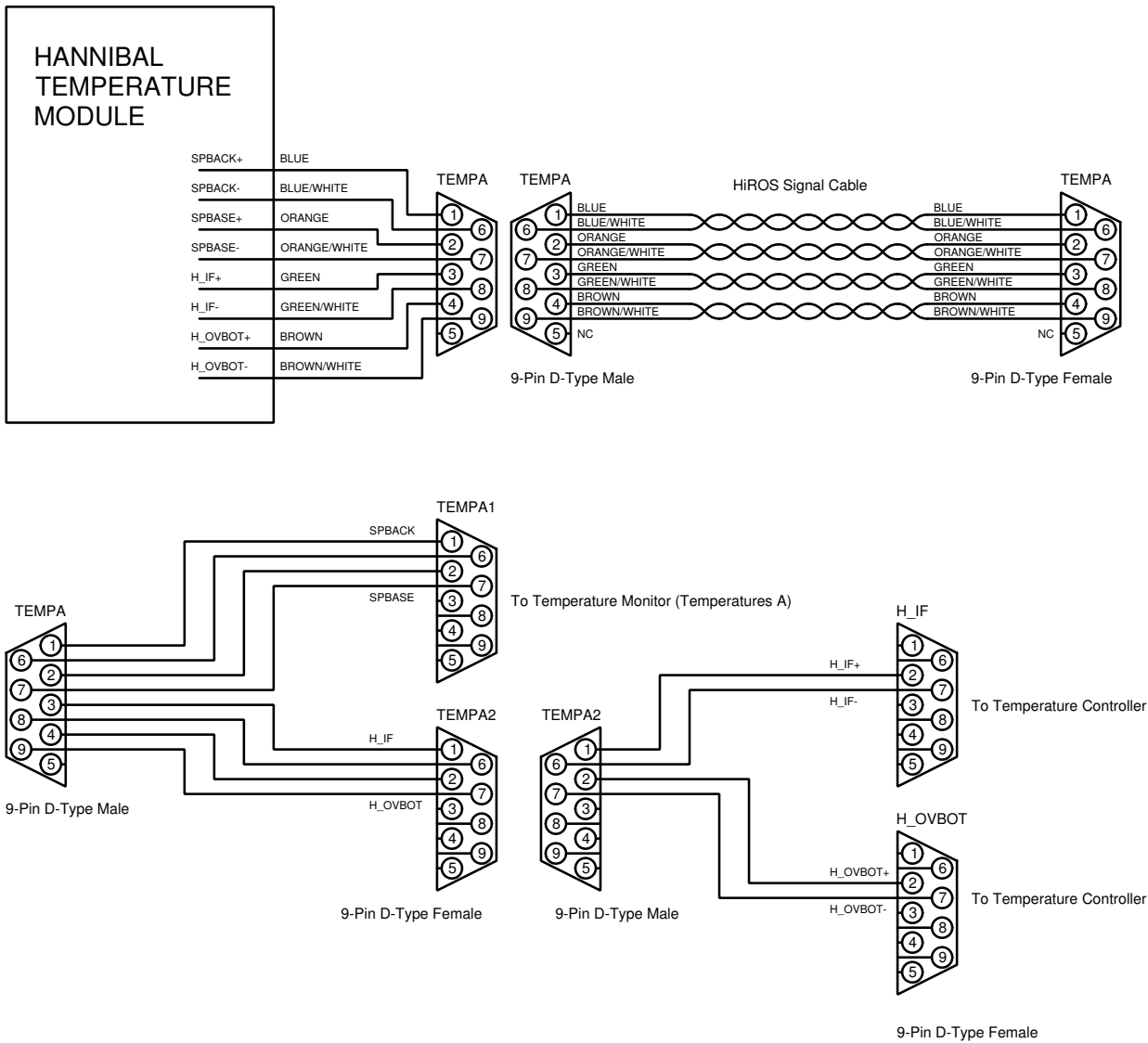

Figure 1: Temperature A “we” cable.

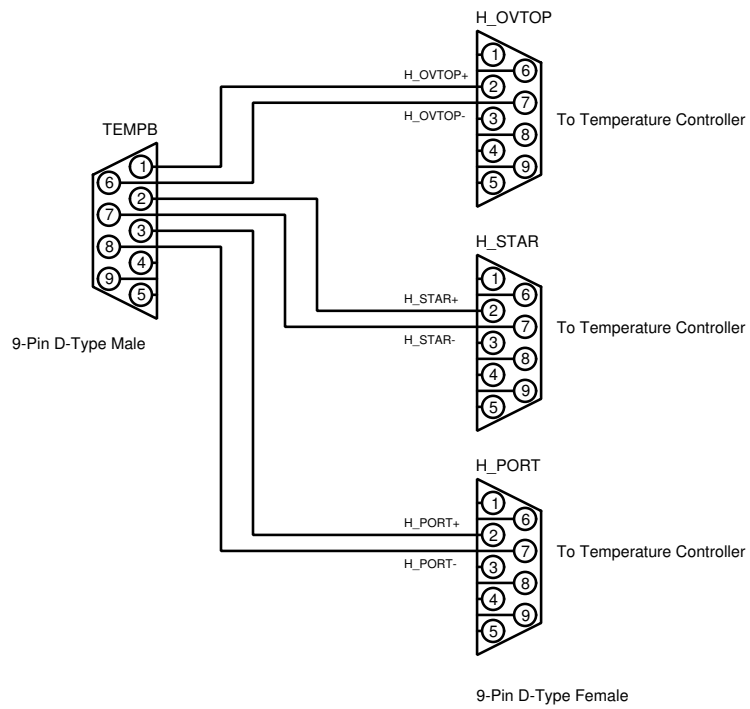
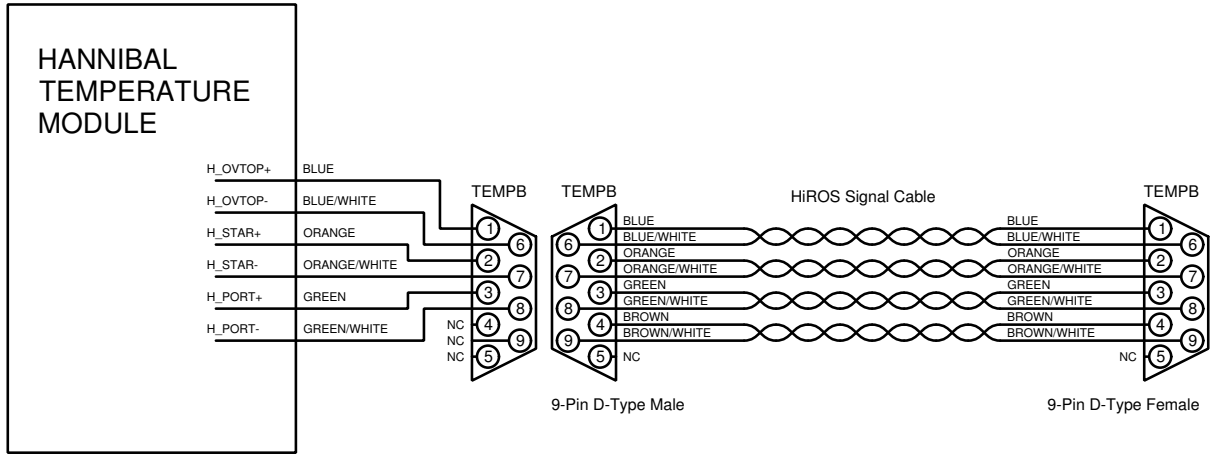

Figure 2: Temperature B “wye” cable.

2.2 Drive Output

The temperature drive outputs were determined by reverse engineering the old temperature controller. The old controller had eight possible temperature modules, of which four were populated. All outputs were passed through a 19-way MIL connector. The pinout is shown in figure 3. Note the mistake on module eight, which would not have worked.

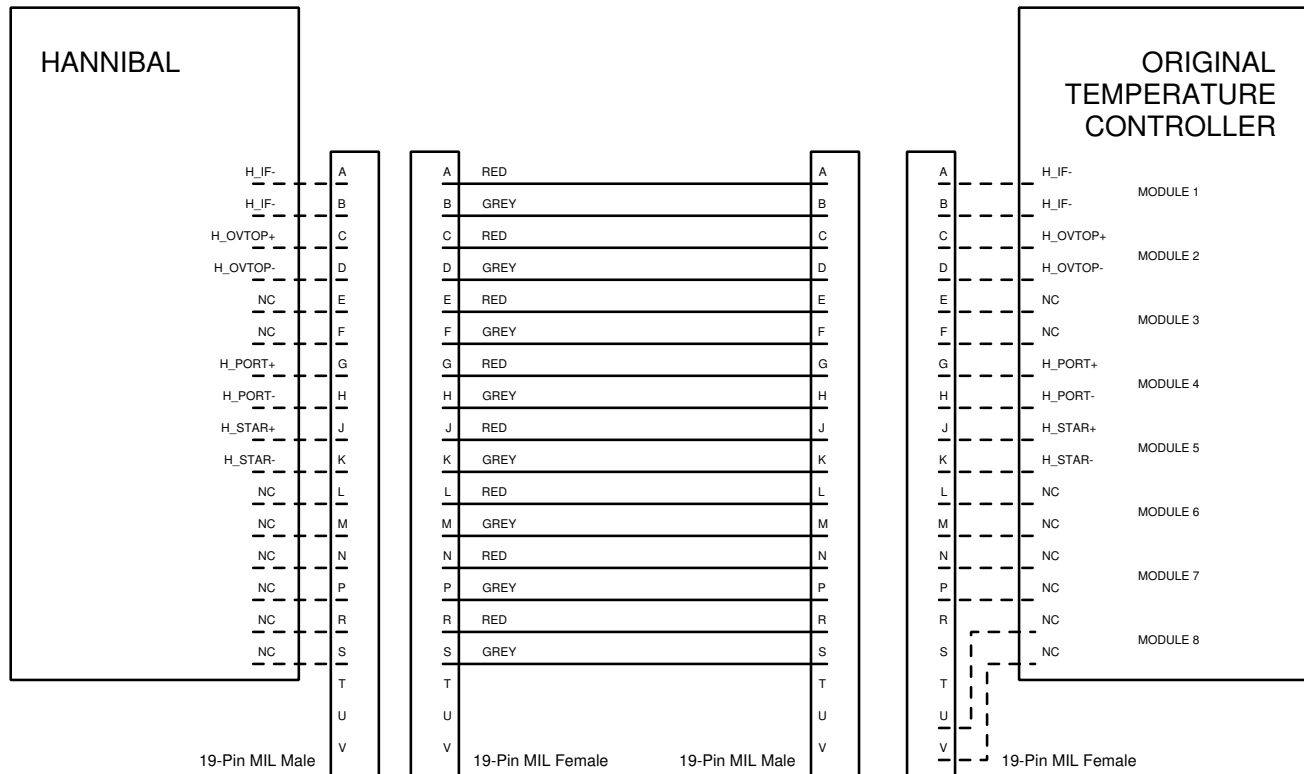

Figure 3: Original Temperature Drive Configuration

The male MIL connector was removed from the existing drive cable, and the four channels in use split out onto four separate D-type connectors suitable for connection to the new temperature controller. The remaining four unused channels were left as isolated tails. The modified drive cable is shown in figure 4.

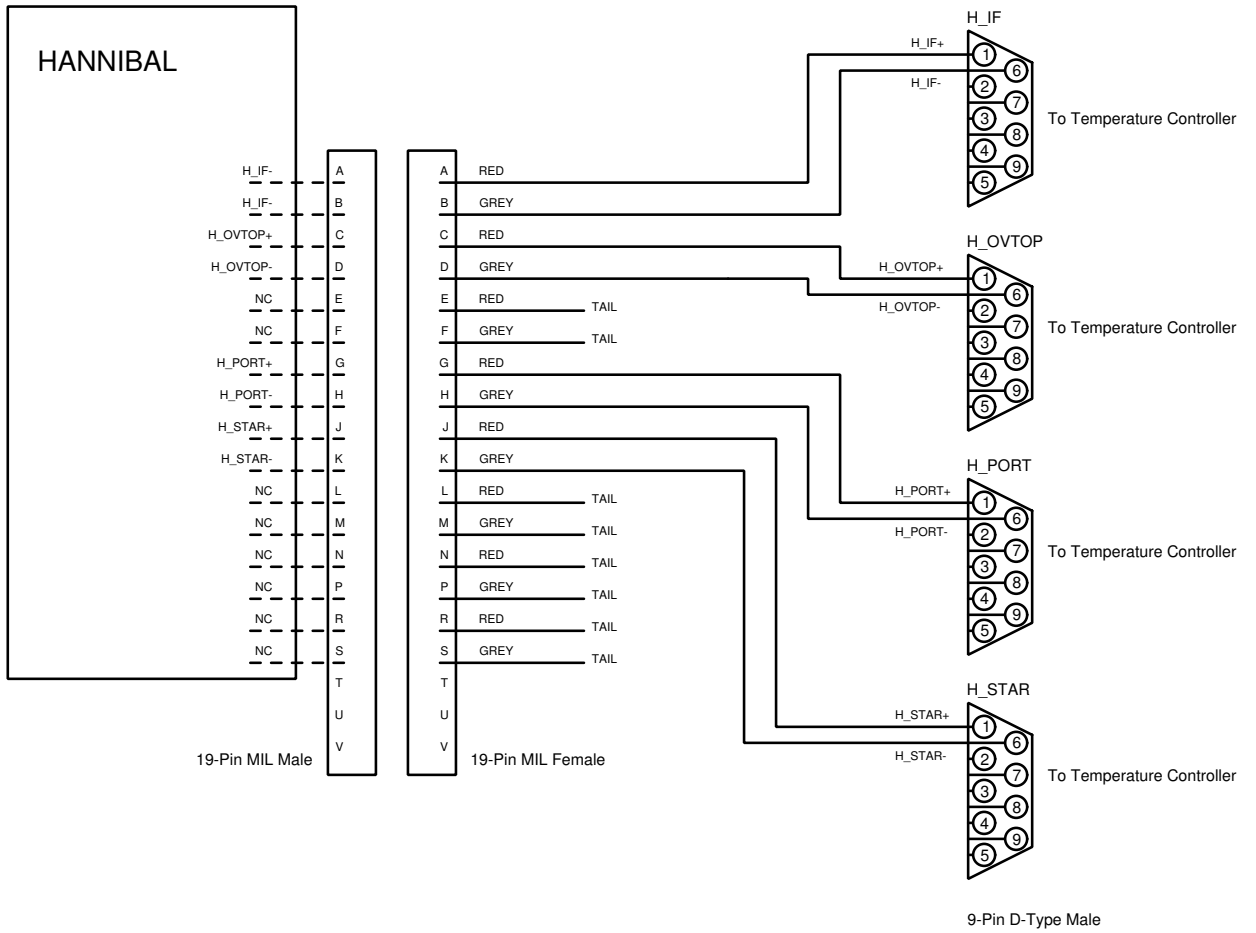

Figure 4: New Drive Cable

3 Internal Configuration

3.1 Input Stage Configuration

The “5generic_v4” temperature controller has five temperature inputs that can be configured for AD590s, LM35s, or pure voltages. A generic input stage is shown in figure 5. The components required to select the different configurations are listed in table 1.

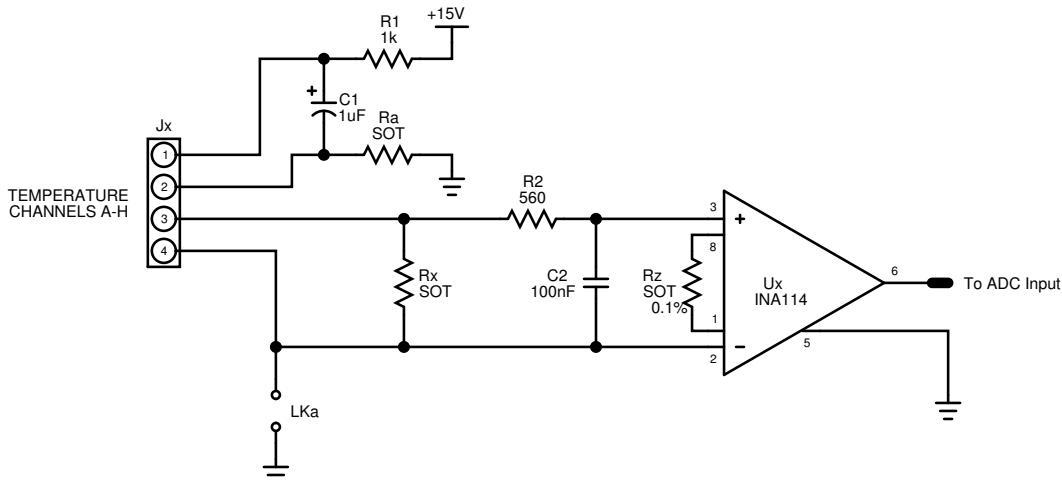

Figure 5: A generic input stage.

Table 1: Component values for different configurations.

<i>Input Type</i>	R_a	R_x	R_z	LK_a
LM35	1 k Ω	10 M Ω	6.8 k Ω	<i>open</i>
AD590	0 Ω	1 k Ω	5.62 k Ω	<i>made</i>
Voltage	0 Ω	10 M Ω	<i>open</i>	<i>open</i>

The specific component names for each of the five channels are listed in table 2. All five channels are configured as pure voltage inputs, as specified by the “voltage” type in table 1.

Table 2: Component names for the five input channels.

<i>Input Channel</i>	R_a	R_x	R_z	LK_a
1	R_6	R_{11}	R_1	LK_{12}
2	R_7	R_{12}	R_2	LK_{13}
3	R_8	R_{13}	R_3	LK_{14}
4	R_9	R_{14}	R_4	LK_{15}
5	R_{10}	R_{15}	R_5	LK_{16}

The temperature controller can accept voltage inputs between 0 V and 5 V. The Hannibal Temperature Module outputs 0.1 V per degree Celsius on the detector and interference filter channels, making a total range of 0 – 50°C. This is acceptable, since none of those components

are intended to go above 50°C . On the two oven channels, the module outputs 0.05 V per degree Celsius, making a total range of $0 - 100^{\circ}\text{C}$. This is not sufficient, since the oven channels are intended to go well above 100°C . For this reason, these two channels have internal signal conditioners to halve the voltage to 0.025 V per degree Celsius, making a total range of $0 - 200^{\circ}\text{C}$. The signal conditioners are simply voltage dividers, shown in figure 6.

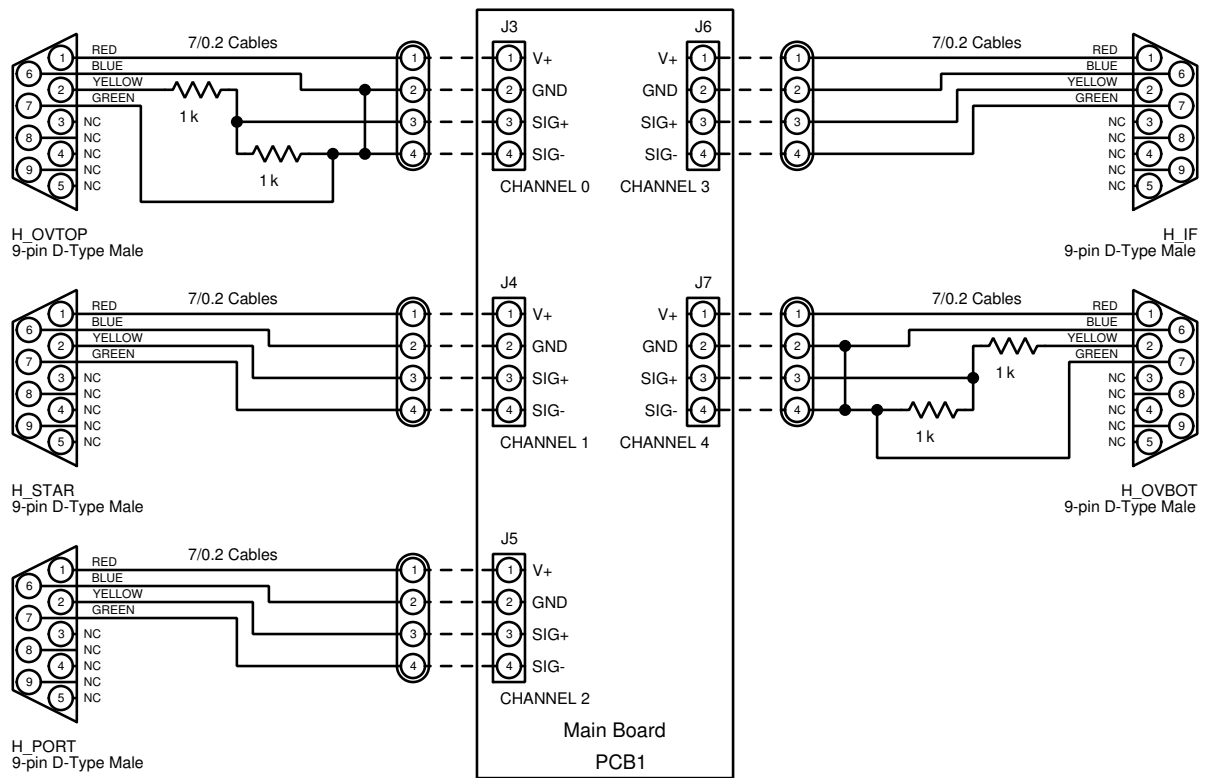

Figure 6: Signal conditioning of channels 0 and 4.

3.2 Output Stage Configuration

The “5generic_v4” temperature controller has eight temperature drive outputs that can be configured for either unipolar or bipolar operation, and a custom current limit. A generic output stage is shown in figure 7. The components required to select the different configurations are listed in table 3.

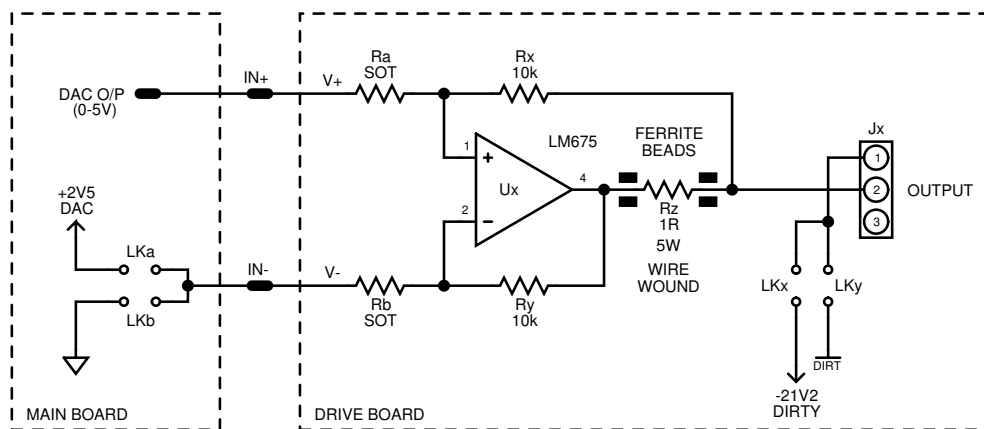

Figure 7: A generic output stage.

Table 3: Output stage configuration.

<i>Component</i>	I_{\max}	R_a R_b	LK _{<i>a</i>}	LK _{<i>b</i>}	LK _{<i>x</i>}	LK _{<i>y</i>}
Heatsink Fan	106 mA	470 k	open	made	made	open
Case Fan	185 mA	270 k	open	made	made	open
Detector	± 0.5 A	47 k	made	open	open	made
Heater	2 A	24 k	open	made	made	open
Heater	0.5 A	100 k	open	made	made	open

The specific component types and configuration for each of the eight channels are listed in table 4. All the channels are configured for unipolar operation, except for the two detector channels which are bipolar.

Table 4: Component names for the eight output channels.

<i>Component</i>	<i>Board and Channel</i>	R_a	R_b	LK _{<i>a</i>}	LK _{<i>b</i>}	LK _{<i>x</i>}	LK _{<i>y</i>}
Detector	A-A	R_4	R_5	LK ₁₈	LK ₁₇	LK ₁	LK ₅
Case Fan	A-B	R_6	R_7	LK ₂₀	LK ₁₉	LK ₂	LK ₆
Heater (2 A)	A-C	R_8	R_9	LK ₂₂	LK ₂₁	LK ₇	LK ₃
Heatsink Fan	A-D	R_{10}	R_{11}	LK ₂₄	LK ₂₃	LK ₈	LK ₄
Heater (0.5 A)	B-A	R_4	R_5	LK ₂₆	LK ₂₅	LK ₁	LK ₅
Detector	B-B	R_6	R_7	LK ₂₈	LK ₂₇	LK ₂	LK ₆
Heater (2 A)	B-C	R_8	R_9	LK ₃₀	LK ₂₉	LK ₇	LK ₃
Heatsink Fan	B-D	R_{10}	R_{11}	LK ₃₂	LK ₃₁	LK ₈	LK ₄

4 Firmware

The temperature controller runs firmware called the “newt”, which is short for “new temperature controller”. The installed version string is

```
newt-2-3.16
```

with SVN revision ID

```
$Id: firmware.tex 6 2015-05-04 23:13:30Z hale $
```

Before the temperature controller is operational, some configuration items need to be set. These are stored in the PIC non-volatile EEPROM memory. This can be done by sending command strings through a terminal emulations program such as Kermit. Start up Kermit using

```
% kermit
C-Kermit 9.0.301 OPEN SOURCE:, 11 Jul 2011, for Linux (64-bit)
  Copyright (C) 1985, 2011,
    Trustees of Columbia University in the City of New York.
Type ? or HELP for help.
(/home/hale/) C-Kermit>
```

and then issue the following commands to configure the serial port, remembering to change the interface name to where ever the device is connected.

```
(/home/hale/) C-Kermit>set line /dev/ttyS0
(/home/hale/) C-Kermit>set modem none
(/home/hale/) C-Kermit>set carrier-watch off
(/home/hale/) C-Kermit>set baud 9600
/dev/ttyS0, 9600 bps
(/home/hale/) C-Kermit>c
Connecting to /dev/ttyS0, speed 9600
  Escape character: Ctrl-\ (ASCII 28, FS): enabled
Type the escape character followed by C to get back,
or followed by ? to see other options.
-----
```

The first parameter that needs to be set is the number of ADC readings between messages sent to the controller. Without setting this, the controller will never send any messages and will appear to be non-operational. The network default is 24 readings between messages, which gives roughly one message per second. This value is set by sending a “\$A” message with the value in hexadecimal, like so

```
$A,0018
```

No confirmation will be sent by the controller, but you should find that you now start to receive “\$ADC” temperature messages.

Next is to set the DAC defaults to use when the controller loses contact with the computer. Generally, you want to set all the outputs to zero. However, there is a complication. For the bipolar outputs zero current is at the mid-range of the DAC. The DAC used by the controller is 12-bit, and so the maximum value in hexadecimal is 0xfff, making the mid-range value 0x800.

The Hannibal temperature controller is configured for two bipolar outputs (channels zero and five) with the remaining outputs unipolar. The defaults are set using a “\$P” message, like so

```
$P ,800 ,000 ,000 ,000 ,000 ,800 ,000 ,000
```

and the controller should respond by sending the same \$P message back as confirmation.

Setting how long it takes for the controller to consider contact with the computer to be lost, and so set the outputs to the fail-safe defaults, is done using a “\$W” message. Any reasonable value is suitable for this. The Hannibal controller is set to allow three normal messages to pass without acknowledgement before entering fail-safe with a message such as

```
$W ,0048
```

which again should return the same \$W message back as confirmation.

Finally, you can calibrate the ADCs using a “\$C” message, like so

```
$C
```

which returns a \$C back as confirmation.

The controller should now be fully operational and under the control of the “Iguana” on the station computer.

References

- [1] IAN BARNES AND BREK A. MILLER. A computer-controlled temperature controller with five configurable inputs. *BISON Technical Report Series*, Number 335, High-Resolution Optical-Spectroscopy Group, Birmingham, United Kingdom, May 2011.
- [2] IAN BARNES, BARRY JACKSON, SUKHPAL S. “PAUL” JAGPAL, AND BREK A. MILLER. The Carnarvon Temperature Monitor. *BISON Technical Report Series*, Number 254, High-Resolution Optical-Spectroscopy Group, Birmingham, United Kingdom, September 2005.
- [3] STEVEN J. HALE AND BREK A. MILLER. The grand opening of the Las Campanas Zoo. *BISON Technical Report Series*, Number 261, High-Resolution Optical-Spectroscopy Group, Birmingham, United Kingdom, February 2006.