

BiSON

Birmingham
Solar-Oscillations
Network

TECHNICAL REPORT NO. 253

Carnarvon Trip Report — May 2005

Ian Barnes and Steven J. Hale

The University of Birmingham, Edgbaston, Birmingham B15 2TT

2005 September 8

This technical report series is published by:



**THE UNIVERSITY
OF BIRMINGHAM**

High-Resolution Optical-Spectroscopy Group

School of Physics and Astronomy
The University of Birmingham
Edgbaston, Birmingham B15 2TT, United Kingdom
Telephone: +44-121-414-4551 FAX: +44-121-414-1438

Carnarvon Trip Report — May 2005

Ian Barnes and Steven J. Hale

The University of Birmingham, Edgbaston, Birmingham B15 2TT

2005 September 8

Abstract

Details of the work undertaken during a trip to Carnarvon during May 2005 is presented.

Contents

1	Introduction	1
2	The “Carnarvon Disaster”	3
3	Dome Rollers	5
4	Mark V Spectrometer	6
5	Jabba Spectrometer	9
6	Temperature Monitor Installation	11
7	Network Camera Installation	13
8	Miscellaneous	17

1 Introduction

Carnarvon was scheduled to be visited before May 2005, however due to circumstances it was postponed several times. It was then decide to send Ian Barnes and Steven Hale on the trip. Due to their relative inexperience of site visits, the tasks to be undertaken were kept to a minimum and included: -

- Fixing the steps that were present in the data from the Mark V instrument.
- Replacing all of the dome rollers.
- Check the limit switches on the shutter mechanism.
- Install a temperature monitor.

- Install a network camera.
- Install some cabinet lights over the small workbench.
- Compile a comprehensive list of all manuals and BTRs that were at Carnarvon.

In total there would be 14 days spent on site in Carnarvon to complete all of the tasks outlined above.

2 The “Carnarvon Disaster”

Two days before flying out to Australia a disaster beset the station. Carnarvon was hit by a freak rainstorm that dumped over three inches of rain over a couple of hours. This amount of rain is very nearly the same amount that Carnarvon can usually expect in a year.

Following the downpour Les Schultz visited the dome and discovered that the power had failed along with the UPS. This meant that the dome had not closed properly and hence there was a flood inside the dome. Upstairs the mount had received a thoroughly good drenching and the water had seeped downstairs onto the main electronics rack.

Les discovered that most things seemed to work with the exception of the V-F converter box for the Mark V instrument. It kept tripping the RCD unit fitted inside the dome. The V-F box was unplugged and found to be full of rainwater. The water was emptied out and the unit was left to dry out.

2.1 UPS

When Les arrived at the station he saw that the dome had not closed properly and so the UPS had failed. Les removed the UPS and took it home so that he could inspect the unit and check if it was working. Les determined that the batteries were not charging and that the charging circuit of the UPS was also broken, in short a new UPS was required.

The UPS that was now deemed to be a write-off was the large 1500VA unit that operated the motors to close the dome during a power failure. The unit was labelled as a Sola UPS 520.

However due to mergers and various acquisitions the Sola brand has been gradually phased out. The Sola UPS 520 that needs replacing is now discontinued and replaced by an equivalent unit branded as a Powerware 5125 which is the equivalent 1500VA unit that is required in Carnarvon. The Powerware website can be found at <http://www.powerware.com/>.

2.2 Keyspan USB to serial port adapter

It was noticed that the GPS unit in Carnarvon had stopped working following the downpour. Further investigation found that the Keyspan USB to 4 port serial hub had got water inside the unit. The unit was taken apart and left to dry out in the sun for a while and then re-assembled.

The unit still didn't appear to be working. It was noticed that the USB cable was rusted inside the connector and the cable. Luckily a spare lead was available from a digital camera but even with the new spare lead the Keyspan failed to work. Obviously the Keyspan was another victim of the flood.

The failure of the Keyspan caused a problem because there were insufficient serial ports to connect the GPS and also the new Temperature Monitor unit that was to be installed during the trip. To overcome this problem a PCI serial card which had two serial ports was purchased and installed into the computer.

2.3 Rain detector

Following the failure of the dome closing it was decided that it would be wise to test the rain sensor seeing as this could be the reason why the dome didn't close and hence a major contributing factor to the disaster.

The sensor was tested by throwing a cup of water over the sensor from the shutter. The sensor didn't detect the water. Following further investigations it was discovered that a wire had become disconnected from the terminal block that is fixed to the skin of the dome.

The wire was reconnected and the rain sensor detected rain which was a good sign. Just to be on the safe side the sensor was allowed to dry out and then tested again with the dome set to automatic. As soon as the water hit the sensor the rain LED was illuminated and the blind began to close as normal. The rain signal was allowed to clear normally and then the test repeated. One thing that was noted was the fact that the rain signal took about an hour to clear which seemed an awfully long time given that it was quite a warm day.

Confident that the rain sensor was working it was decided to leave the dome on automatic in an attempt to gather some data as we had looked at the detectors in Jabba (discussed later). When we returned to the dome the following morning it had been raining and the dome had not closed. More rain had gone into the dome but at least the water had gone straight down the steps and further damage to the electronics was avoided.

It would appear that the rain detector may have been the cause of the "Carnarvon Disaster" after all. It should be replaced at the earliest opportunity.

3 Dome Rollers

Carnarvon was the first station to use a dome and was commissioned in 1985. In its 20 year history the dome rollers have never been changed. It had become impossible to move the dome by hand with the motor disengaged.

There was a dome roller kit in the bunker at Carnarvon. The kit contains dome rollers, roller plates, rubber cushions and replacement nuts and bolts. Although there were sufficient rollers there weren't enough of the other parts to replace everything.

The weather strip has to be removed to gain access to the dome rollers and the dome motor needs to be disengaged from the track. In order to change one of the dome rollers the following procedure is used:

- Remove all four bolts securing the dome roller plate.
- Loosen bolts on the rollers immediately next to the one to be changed.
- Using a crowbar as a lever lift the dome.
- Remove old roller with plate and replace with new one.
- Lower dome back into position.
- Replace bolts securing the roller plate.

The design of the dome rollers has changed slightly since the Carnarvon dome was assembled. Originally there was a roller wheel and a separate shaft whereas the newer version the shaft and wheel is one complete unit.

Several problems were encountered when changing the rollers. Although some of the rollers were very simple to change, some of the others were far from easy. Some others proved impossible to change.

The main problem was that when undoing the nut a tight spot on the thread of the bolt caused the whole bolt to spin. Unfortunately it was not possible to get to the head of the bolt with a spanner. Holding the bolt with a pair of locking pliers damaged the thread, as did cutting a slot in the bolt.

As many rollers as was practicable were changed which turned out to be roughly half of them. The improvement in mobility of the dome was quite spectacular. The dome can now be turned by hand. When the computer moves the dome it often shoots past the intended position and has to be stepped back. This could be corrected by cutting the wire for the least significant bit of the dome encoder. But it was decided not to do this because in time the rollers will probably tighten up again.

4 Mark V Spectrometer

The main task that related to the Mark V spectrometer was to see if the cause of the steps could be determined. This usually means that something has become loose inside the unit. The covers were removed and the inside was checked for anything that appeared to be loose or missing. All seemed well and so the covers were replaced.

Mark V stopped working after the flooding and so it was obvious that some of the electronics had broken. Now it was a case of finding out what.

A block diagram of the signal path for the Mark V spectrometer is given in Figure 1.

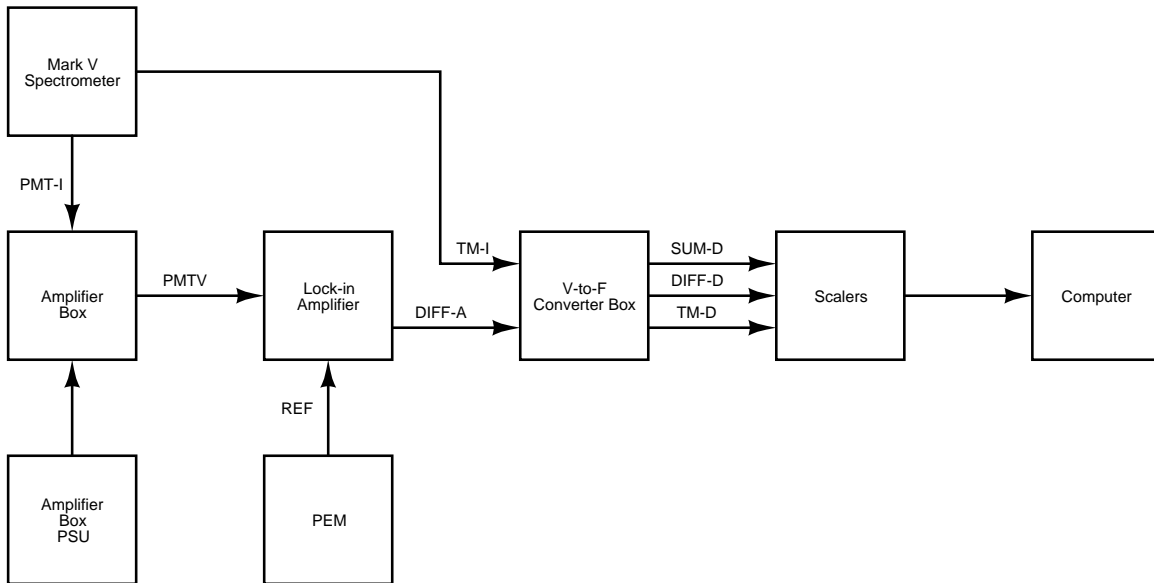

Figure 1: Mark V System Configuration

The current signal from the photomultiplier tube (PMT-I) is fed into the amp box. This box converts this current to a voltage (PMT-V) which is then fed to the lock-in amplifier and also goes through an integrator circuit to produce the Sum analogue voltage signal.

The lock-in amplifier is fed a reference signal from the PEM (photoelastic modulator) and produces the analog difference signal (Diff). The Sum and Diff signals then go into the V-F converter box which converts the analogue voltages into pulses that can be counted by the scalars.

4.1 Amp Box

The amp box is a small box that accepts the input signal from the photomultiplier tube in Mark V and generates various analog voltages that are passed on to other stages of the system.

The amp box get its power from its own small power supply unit. The fuse had blown in this and was replaced. The amp box was considered to be damaged and hence the covers removed so that the board could be checked for visible signs of water damage. There weren't any real signs of water damage but the PCB was cleaned with switch cleaner anyway.

4.2 Lock-in Amplifier & PEM

The lock-in amplifier is a commercially available unit manufactured by EG&G. There was a great deal of concern over this unit. On arrival the “Ref Low” light was on which indicated a problem with the PEM. However the PEM was tested and found to be working perfectly.

There was a spare lock-in amplifier actually on site but after plugging it in it seemed completely dead. The fuses were checked but they were okay. The phase dial on the unit seemed to be very sticky so it was decided to swap it for the one on the dead unit. However after removing both pot dials it became apparent that the dial fitted was actually better than the one on the dead unit. So the original dial was re-fitted and this seemed to cure the sticking problem.

The PCBs within the lock-in amplifier were sprayed with switch cleaner and the unit put back together.

4.3 V-F Converter Box

Les Schultz discovered that the V-F converter box was full of water and after emptying it out left the unit to dry out. After removing the lid of the box it soon became apparent that this box was a complete write-off. The PCBs were heavily corroded and there was evidence of the encapsulation on the transformer bubbling due to heat generated whilst the unit was short-circuited.

A spare PCB and parts were taken out in case they were needed and so it was possible to re-build the box. The spares that were on site however did not include parts to rebuild the power supply.

To get around this problem DC power could be taken from the Jabba power supply box directly. This box has regulated rails of $\pm 5\text{ V}$, $\pm 15\text{ V}$ and $\pm 19\text{ V}$. By using the $\pm 15\text{ V}$ and 5 V supplies from Jabba and removing the LM325 tracking regulators the need for a new power supply for the V-F converter box was eliminated.

The main PCB in the V-F box was badly corroded and had to be replaced. However the spare board that was available was slightly different to the one that was fitted. Since the Carnarvon unit was constructed and the replacement board being made one of the ICs had become obsolete. The 75121 chips were replaced on the newer board by a FET and a transistor that replicated the function of the obsolete IC.

The Soclaire VFC-102A voltage-to-frequency converters also had signs of corrosion on the circuit boards, and so these were also changed. These ICs are also now obsolete but the group still has a few spares remaining.

The box was finally re-wired and plugged back into place. It worked although the pulses were a lot smaller in amplitude than normal and couldn't be detected by the scalars.

The repaired V-F box was only a temporary fix because it has long leads that carry the power from the Jabba power box. This unit will have to be replaced in a future visit.

4.4 Mark V Recommendations

Since the V-F box has been all but destroyed it makes sense to completely re-design this part of the system. It would be better to build a brand new unit that houses the power supply, amp box and V-F converters in one standard 1U rack case.

At the same time all of the obsolete ICs should be designed-out and modern day equivalents be used instead.

By adopting a single box for the Mark V electronics we will be able to clear a complete shelf of the rack which will give us extra space for other equipment.

5 Jabba Spectrometer

Following the “Carnarvon Disaster” the data from Jabba was a little strange. It appeared that two of the detectors had stopped working as was the case with the transmission monitor, whilst the other two detectors were showing spurious results. Maybe when the rain poured in through the opening water had landed on Jabba and found its way onto the electronics within the instrument. There was only one way to find out for sure, and that was to remove the covers and have a look.

5.1 Pockels-Cell

One of the tasks for the trip was to install a second Pockels-Cell into Jabba. Apparently George Isaak had taken two Pockels-cells along with a dual mount with him on a previous trip to Carnarvon. It was unclear whether the Pockels-Cell had been left in the dome or in fact fitted inside Jabba. Since the covers had to come off Jabba anyway it was decided to look at the Pockels-Cell first as wiring it up would be a simple task.

On removing the covers it was plain to see that there was only one Pockels-Cell mounted inside Jabba. Furthermore the mount looked like it couldn't hold another Pockels-Cell. It looked like George hadn't had time to fit the Pockels-Cell so it must be in the dome somewhere. After an extensive search of the dome no Pockels-Cells or anything resembling a mount were found.

5.2 Jabba Detectors

The next task was to have a look at the detectors. One of the completely dead detectors was removed from Jabba and dismantled. Inside the detector housing the photodiode had got water inside the detector window. Also the Peltier cooler was badly corroded as were some of the solder joints for the cable. Other detectors were examined and were found to be in a similar state. It would appear that Jabba and Mark V got very wet when the opening was left open and the water has seeped into the instruments and caused damage.

The two forward detectors were removed completely from Jabba so that they could be returned to Birmingham for further analysis. The two aft sensors were relocated to the forward positions. Although they are probably damaged these were the two detectors that were showing spurious readings. It was hoped that some data could be gathered the following morning to confirm if they are in fact broken.

Sadly the weather was not good and so no data was collected. The rain sensor failed again, and so the detectors that were re-installed as a test were left inside the unit as there was no time to remove them to bring them back to Birmingham.

5.3 Jabba Recommendations

Due to the damage that was present in the detectors that were examined it is best that all four units and the transmission monitor are replaced. Sadly there was insufficient time to remove the other detectors and transmission monitor so new boards will have to be made and these fitted on site.

Once again obsolescence raises its ugly head. The photodiode that is used in the detectors is a HUV4000 manufactured by EG&G. These photodiodes are no longer used within the group and so new detectors should be designed around the Centronic OSD-100/5T 100 mm² Blue-sensitive Silicon Photodiode that was used in the Izaña Transmission Monitor [1].

Jabba also uses the obsolete Soclaire VFC-102A voltage-to-frequency converters which are mounted inside the main instrument. Because Jabba must have taken on a fair amount of water which caused the damage to the detectors there is a strong possibility that these ICs are also damaged. It would be wise to design-out the obsolete components just to be on the safe side.

6 Temperature Monitor Installation

One of the tasks of this trip was to install a temperature monitor unit. Each temperature monitor unit can be configured to measure up to 16 sensors and BTR-254 details the building of the Carnarvon unit.

The temperature monitor as used in Carnarvon uses all 16 channels and the channels have been allocated as shown in Table 1.

Table 1: Temperature Channels

0	Aft Starboard Detector
1	Aft Port Detector
2	Water Tank Temperature
3	Dome Ambient Temperature
4	Interference Filter
5	Ambient
6	Fore Oven Top
7	Fore Oven Bottom
8	Fore Starboard Detector
9	Fore Port Detector
10	Aft Oven Top
11	Aft Oven Bottom
12	RA
13	RA
14	DEC
15	DEC

6.1 Temperature Monitor System Diagram

Figure 2 shows how the temperature monitor system as used in Carnarvon is configured.

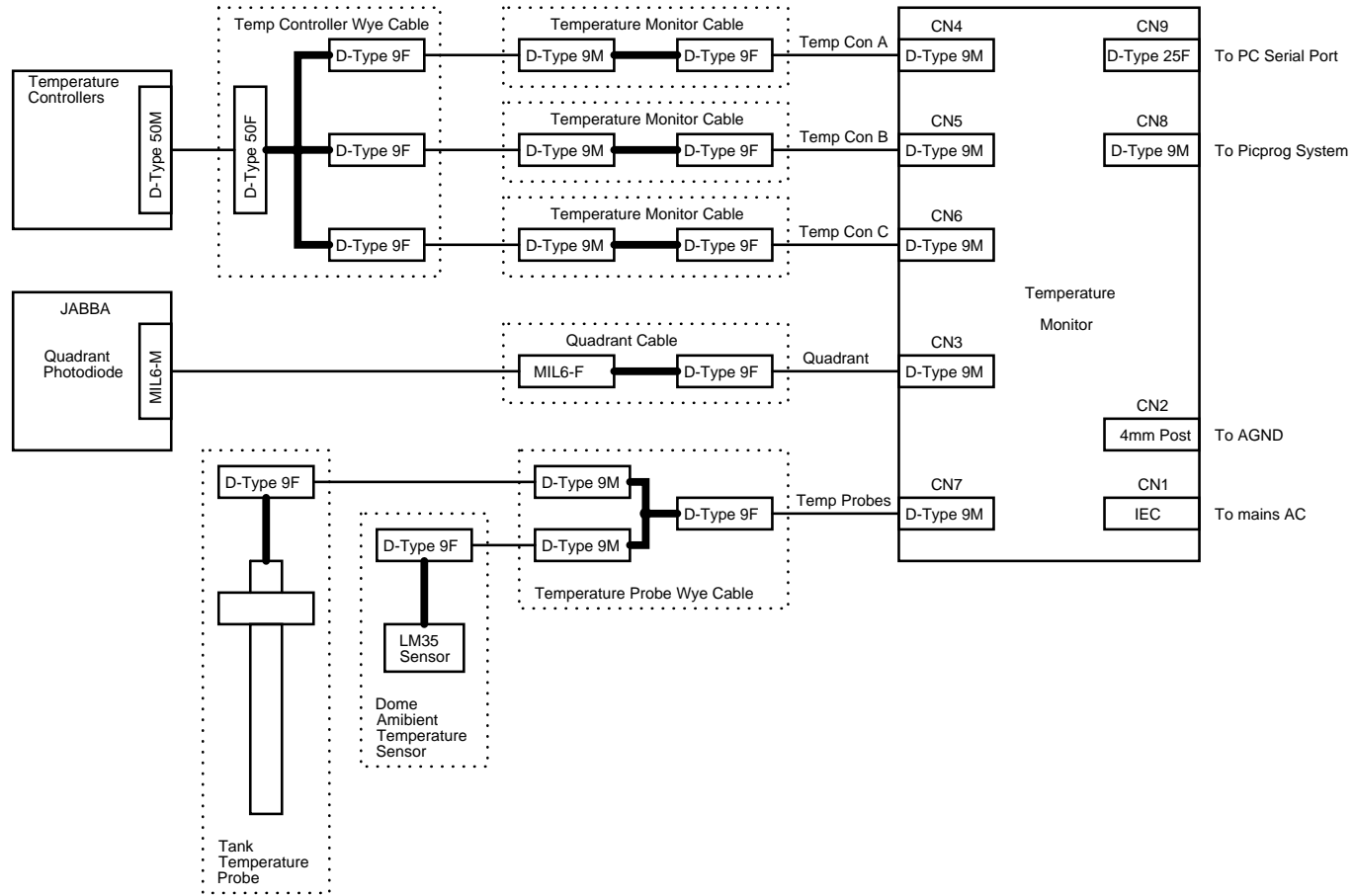

Figure 2: Carnarvon Temperature Monitor System Configuration

7 Network Camera Installation

An Axis 205 Network Camera has been installed in the dome. It is attached to the dome just to the right of the shutter and is pointed back at the mount. It moves around in azimuth with the dome but it does not move up and down with the shutter.

The network camera has been assigned its own IP address, which is 192.168.1.2. It is possible to access the camera through the dome computer. You can login on the dome computer and get a single image:

```
% cd tmp
% wget http://192.168.1.2/jpeg/image.jpg
% xv image.jpg
```

7.1 Network Camera Cables

The network camera requires two cable connections: one for the network and one for power. In order to make the installation easier and to reduce the number of cables connecting to the dome, the power for the camera is sent upstairs on one of the unused twisted pairs inside a normal network cable. Two “wye” adaptors are used, one to put the power into the cable at the bottom and another to get the power back out again at the top next to the camera. The main camera cable is shown in Figure 3. The wye adaptors are shown in Figure 4 and Figure 5.

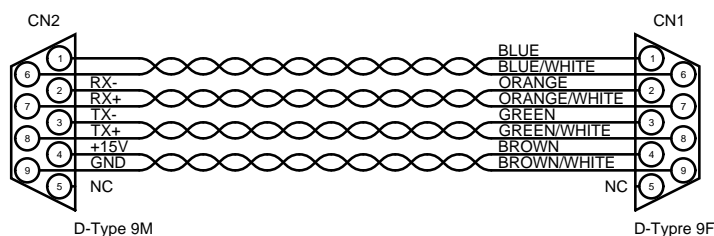

NOTES:-

1. Cable -4-pair, 7/0.2 UTP Yellow PVC Sheath.

Figure 3: Network Camera Cable

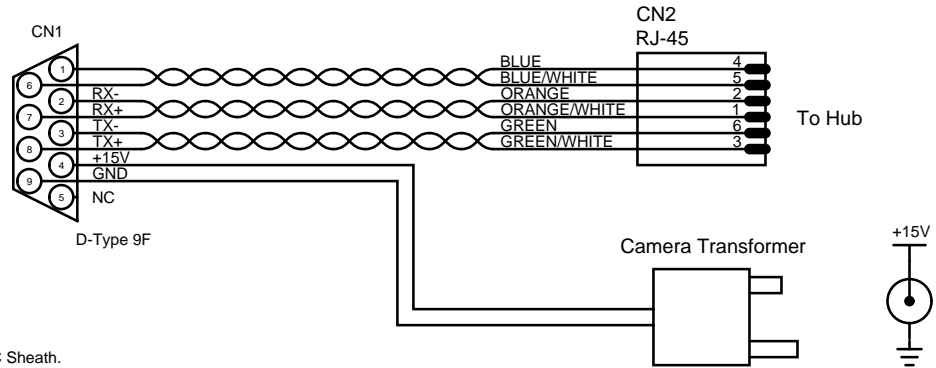

NOTES:-

1. Cable -4-pair, 7/0.2 UTP Red PVC Sheath.
2. The pins of the RJ-45 connector are numbered from right to left, looking into the male connector with the locking tab at the bottom.

Figure 4: Power in Wye Cable

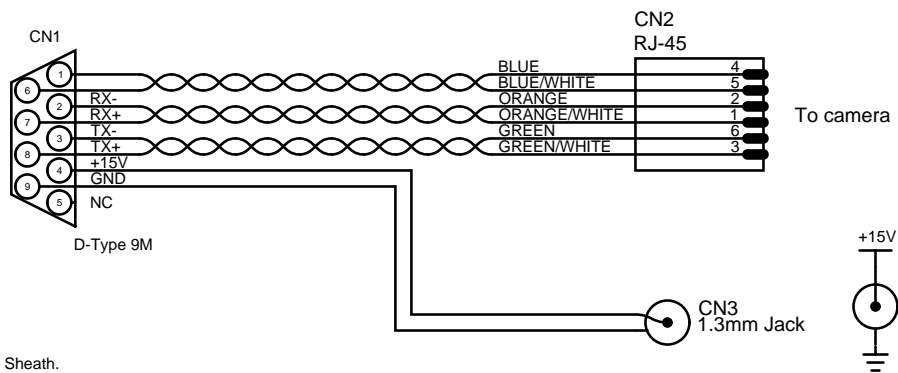

NOTES:-

1. Cable -4-pair, 7/0.2 UTP Red PVC Sheath.
2. The pins of the RJ-45 connector are numbered from right to left, looking into the male connector with the locking tab at the bottom.

Figure 5: Power Out Wye Cable

7.2 Camera Mounting Bracket

Although the network camera does come with a mounting bracket it is unsuitable for mounting directly to the dome. Therefore a new mounting bracket is needed. A drawing of the mounting bracket for the network camera is given in Figure 6.

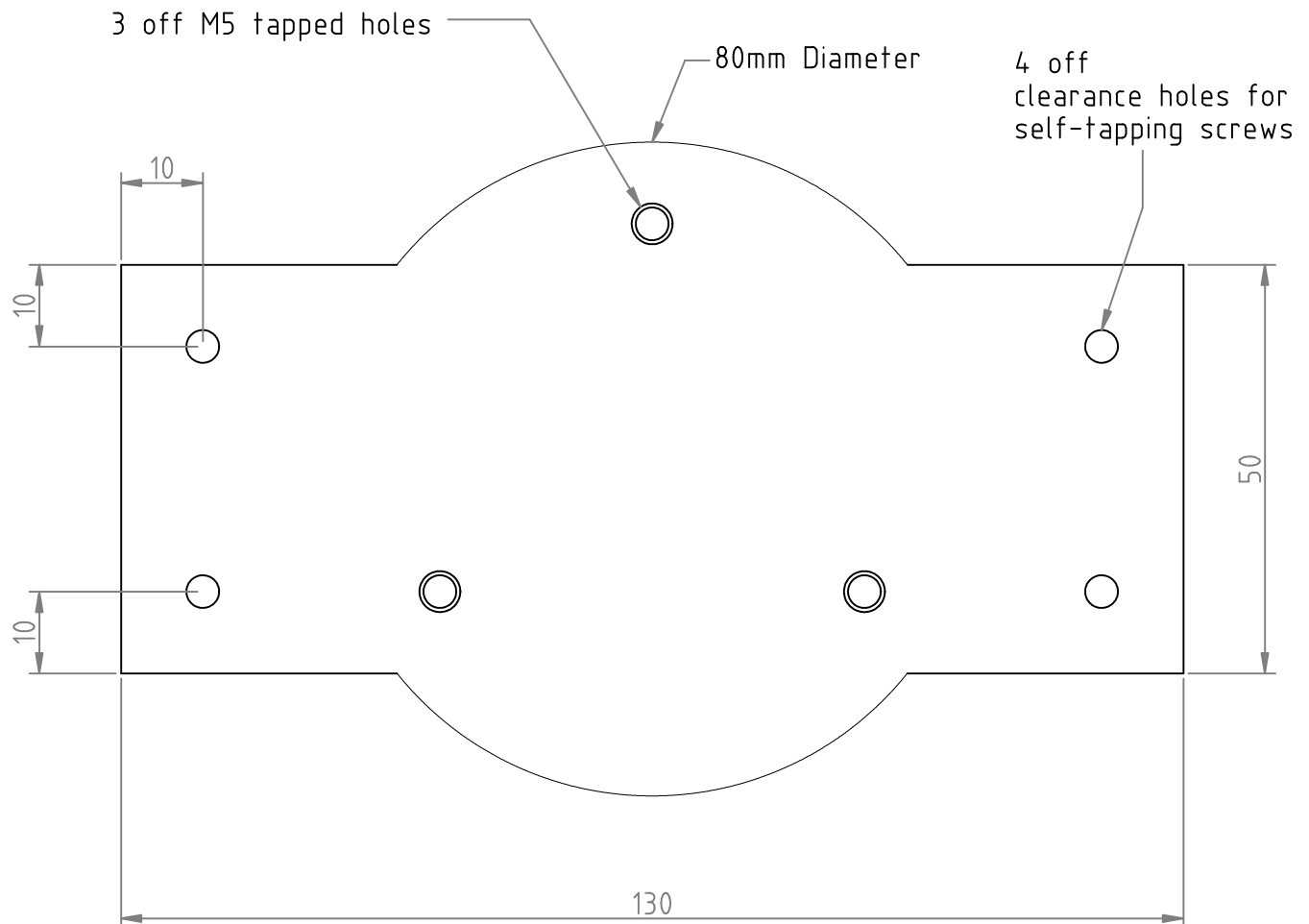

NOTES:-

Material 1/4" Aluminium Plate.

M5 tapped holes to suit mounting bracket supplied with camera

Figure 6: Network Camera Mounting Bracket

7.3 Parts List

All of the parts required to install a network camera are given in Table 2.

Table 2: Network Camera Parts List

	Part Number	Description	Unit Cost
-	Axis 205	Network Camera	125.00
-	-	HiROS Network Camera Mount	0.00
-	Rapid 19-4424	4-Pair 7/0.2 Yellow 10m Patch Lead	1.88
-	Rapid 19-4406	4-Pair 7/0.2 Red 3m Patch Lead	0.50
-	Rapid* 15-0500	9-Pin D-type Connector Male	0.235
-	Rapid* 15-0525	9-Pin D-type Connector Female	0.36
-	RS 480-125	9-Pin D-type Connector Shell (10)	1.207
-	Rapid 19-7260	Cross-Wired Cat 5 Lead 3m	2.48
-	Rapid 19-8136	RJ-45 Line Coupler	1.68

*These items are available from Physics Stores.

8 Miscellaneous

8.1 Cabinet Lights

Since the dome has got no windows at all the lighting is pretty dim. The small workbench was particularly bad especially for intricate work such as soldering. To overcome this problem some Christmas tree lights were installed but alas these were not bright enough.

Some cabinet lights were bought on a previous trip but were not installed due to time limitations. These cabinet lights have now been put up and there is plenty of light on the bench now.

8.2 Limit Switches

Another of the tasks for the trip was to check that the limit switches on the dome mechanism worked properly without overrunning. The dome was switched to manual control and the blind and shutter mechanisms were cycled several times and the limit switches were operating correctly.

8.3 Ethernet Card

Following the installation of the network camera the computer stopped working. It simply would not boot up at all. The memory and all of the PCI cards were removed from the motherboard and reseated. The computer then managed to boot without any problems. However during the checking it was noticed that the network camera had stopped working and this device is connected to the Ethernet card of the computer.

When the Ethernet card was re-seated in the computer it was noticed that there was “DED” written on the card and so there have obviously been some problems with it in the past. There was also evidence of rust around the RJ-45 connector and so it was deemed that the card was now faulty and should be replaced on the next trip to the station.

References

- [1] IAN BARNES, STEVEN J. HALE, BARRY JACKSON, AND BREK A. MILLER. PD/VFC #2—A detector for the Izaña transmission monitor. *BISON Technical Report Series*, Number 249, High-Resolution Optical-Spectroscopy Group, Birmingham, United Kingdom, July 2005.
- [2] IAN BARNES, BARRY JACKSON, SUKHPAL S. “PAUL” JAGPAL, AND BREK A. MILLER. The Carnarvon Temperature Monitor. *BISON Technical Report Series*, Number 254, High-Resolution Optical-Spectroscopy Group, Birmingham, United Kingdom, September 2005.