

# BiSON

Birmingham  
Solar-Oscillations  
Network

TECHNICAL REPORT NO. 218

## BeebSub #56A and BeebSub #56B — BBC Computer Substitutes

Ian Barnes, Barry Jackson, and Brek A. Miller  
*The University of Birmingham, Edgbaston, Birmingham B15 2TT*

2003 November 20

This technical report series is published by:



**THE UNIVERSITY  
OF BIRMINGHAM**

### High-Resolution Optical-Spectroscopy Group

---

School of Physics and Astronomy  
The University of Birmingham  
Edgbaston, Birmingham B15 2TT, United Kingdom  
Telephone: +44-121-414-4551 FAX: +44-121-414-1438



# BeebSub #56A and BeebSub #56B — BBC Computer Substitutes

Ian Barnes, Barry Jackson, and Brek A. Miller  
*The University of Birmingham, Edgbaston, Birmingham B15 2TT*

2003 November 20

## Abstract

The BBC Computer Substitutes in Izaña are described.

## 1 Introduction

In 2003 December, the old BBC computer that was collecting Mark I data from the BBC scalers was replaced with a new PC. The BBC scalers [1] have a 10-ms window in which the data can be read. Although the typical interrupt latency for the Izaña PC is  $25\ \mu\text{s}$ , the worst-case latency measured while the system is under a heavy load is 30 ms. This means that if the computer tries to read the data from the scalers itself, it may miss points.

To solve this problem, we have created a BBC Computer Substitute (BeebSub) which reads the data from the scalers in place of the BBC computer. It then forwards the data to the new PC over an RS-232 connection.

Two of these devices were built and sent to Izaña in 2003 December. They are called BeebSub #56A and BeebSub #56B. The first device actually started out as PIC Development System #3 (Picdev #3) [2]. It was used to test the interrupt latency of the PC and was then transformed into BeebSub #56A.

## 2 Design

The BeebSub is a 1U rack case containing two main boards: the Supply Board and the PIC Board.

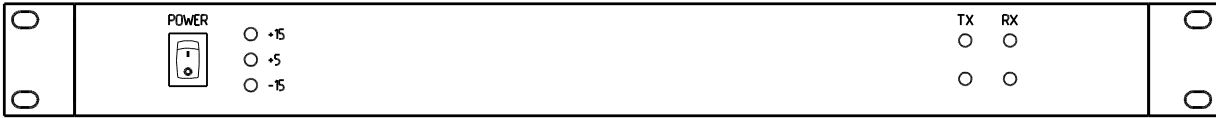

**Figure 1:** The front panel.

### 3 Front Panel

The front panel is shown in Figure 1. It contains a main power switch, three LEDs to verify that the power supply is working, and four LEDs to show the state of the RS-232 lines.

### 4 Connections

The rear-panel is shown in Figure 2. The rear-panel connectors are shown in Table 1. The pin-out of the RS-232 connector is shown in Table 2.

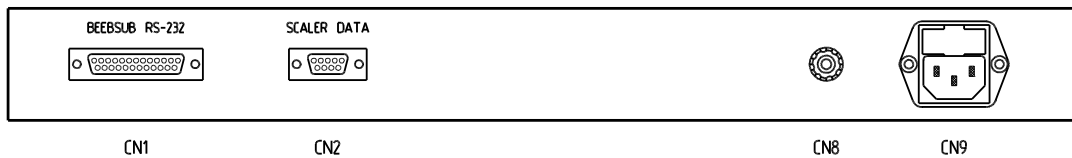

**Figure 2:** The rear panel.

**Table 1:** Rear-Panel Connectors

	<i>Connector</i>	<i>Label</i>	<i>Description</i>
CN1	25-pin female D	BeebSub RS-232	Serial data
CN2	9-pin female D	Scaler Data	
CN8	black 4-mm		Analog ground
CN9	male IEC		Mains

**Table 2:** RS-232 Connector (CN1)

<i>Pin</i>	<i>Label</i>	<i>Description</i>
1	CGND	Chassis ground
2	TxD	Transmit data to BeebSub
3	RxD	Receive data from BeebSub
7	GND	Signal ground

**Table 3:** Scaler Data Connector (CN2)

<i>Pin</i>	<i>Signal</i>	<i>Header Pin</i>	<i>PIC Pin</i>	<i>PIC Name</i>	<i>Description</i>
1	$\overline{MT}$	1	33	RB0/INT	Not empty
2	CB1	2	34	RB1	Next digit is ready
3	CB2	3	35	RB2	Request next digit
4	D0	5	37	RB4	Data
5	D1	6	38	RB5	Data
6	D2	7	39	RB6/PGC	Data
7	D3	8	40	RB7/PGD	Data
8	DGND	10			Digital Ground
9	CGND	12			Chassis Ground

**Table 4:** Scaler-Data Cable

Station: Izana.

Cable: 12-wire, 7/0.2-mm, Shielded.

Length: 6 m

<i>Cable Label:</i>	Scaler Data	Scaler Data	
<i>Connects to:</i>	BeebSub	BBC Scalers	
<i>Connects to Label:</i>	Scaler Data	<i>none</i>	
<i>Connector:</i>	9-pin male D	14-pin male IEEE-488	
$\overline{MT}$	1	6	black
CB1	2	12	brown
CB2	3	13	red
D0	4	2	orange
D1	5	3	yellow
D2	6	4	green
D3	7	5	blue
Digital Gnd	8	{ 1 7 11	violet grey white
Chassis Gnd	9	—	shield

## 5 Supply Board

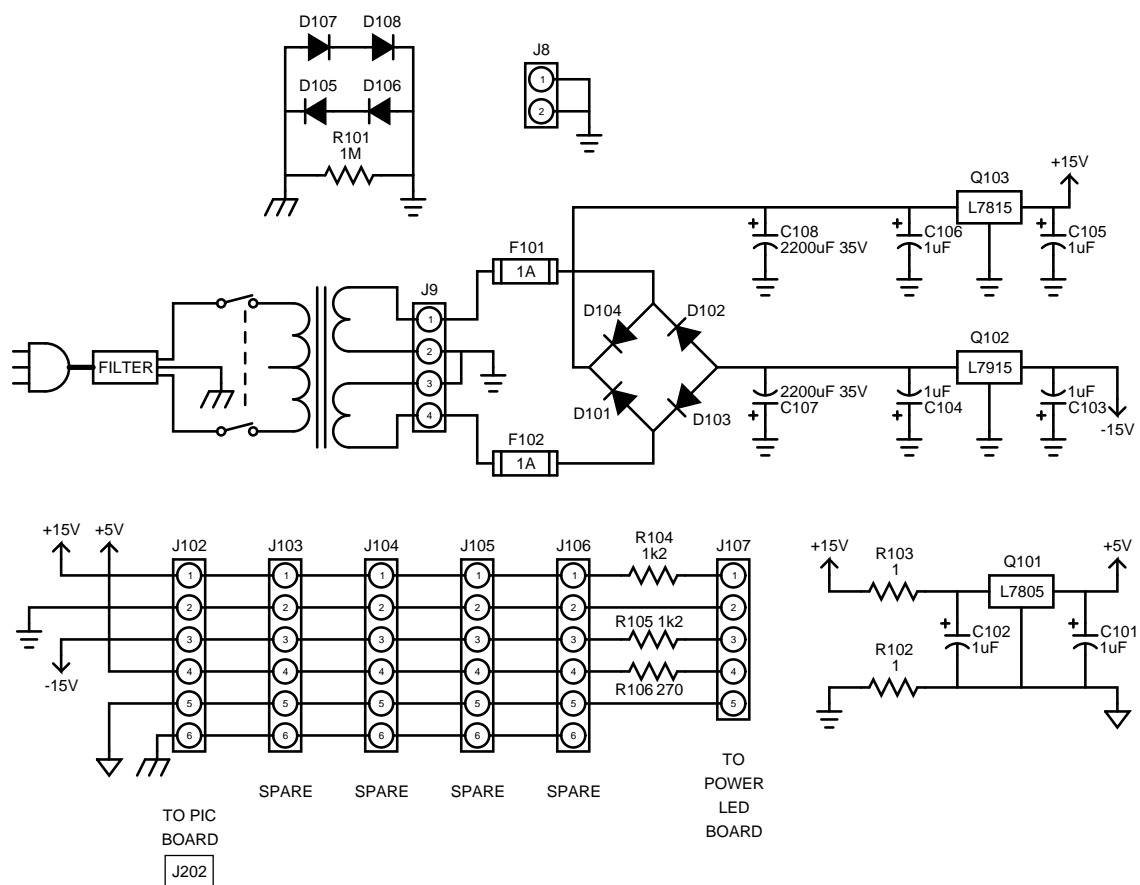

**Figure 3:** Circuit drawing for the Supply Board.

The Supply Board supplies regulated  $\pm 15\text{ V}$  and  $+5\text{ V}$  to the BeebSub. The circuit schematic is shown in Figure 3. This is a single-sided board. The component layout and bottom-side tracks are shown in Figure 4 on the next page.

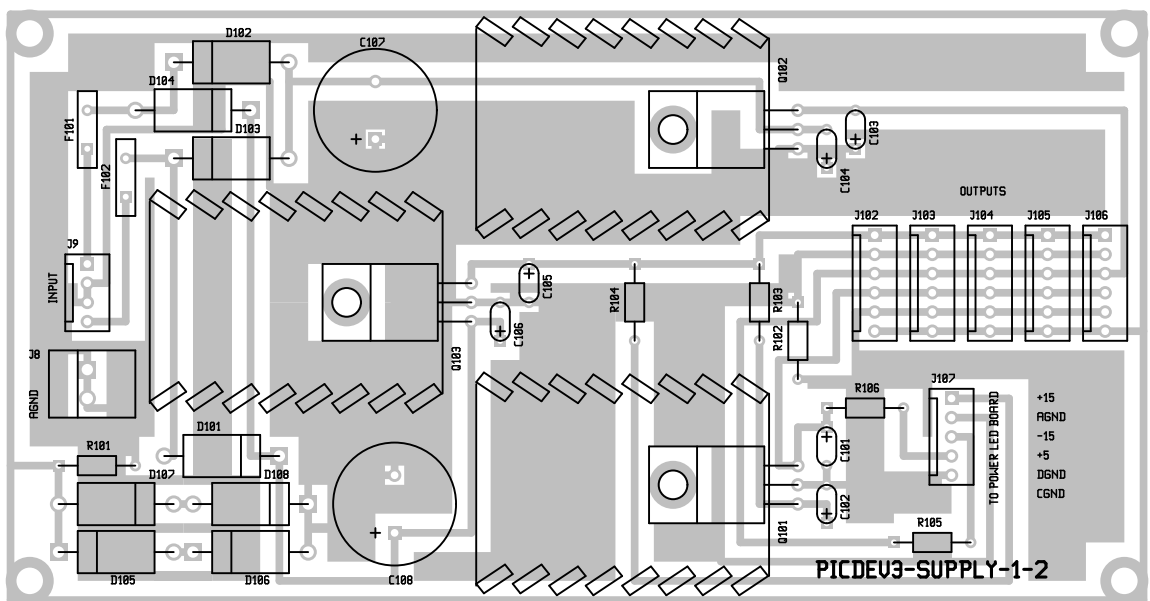
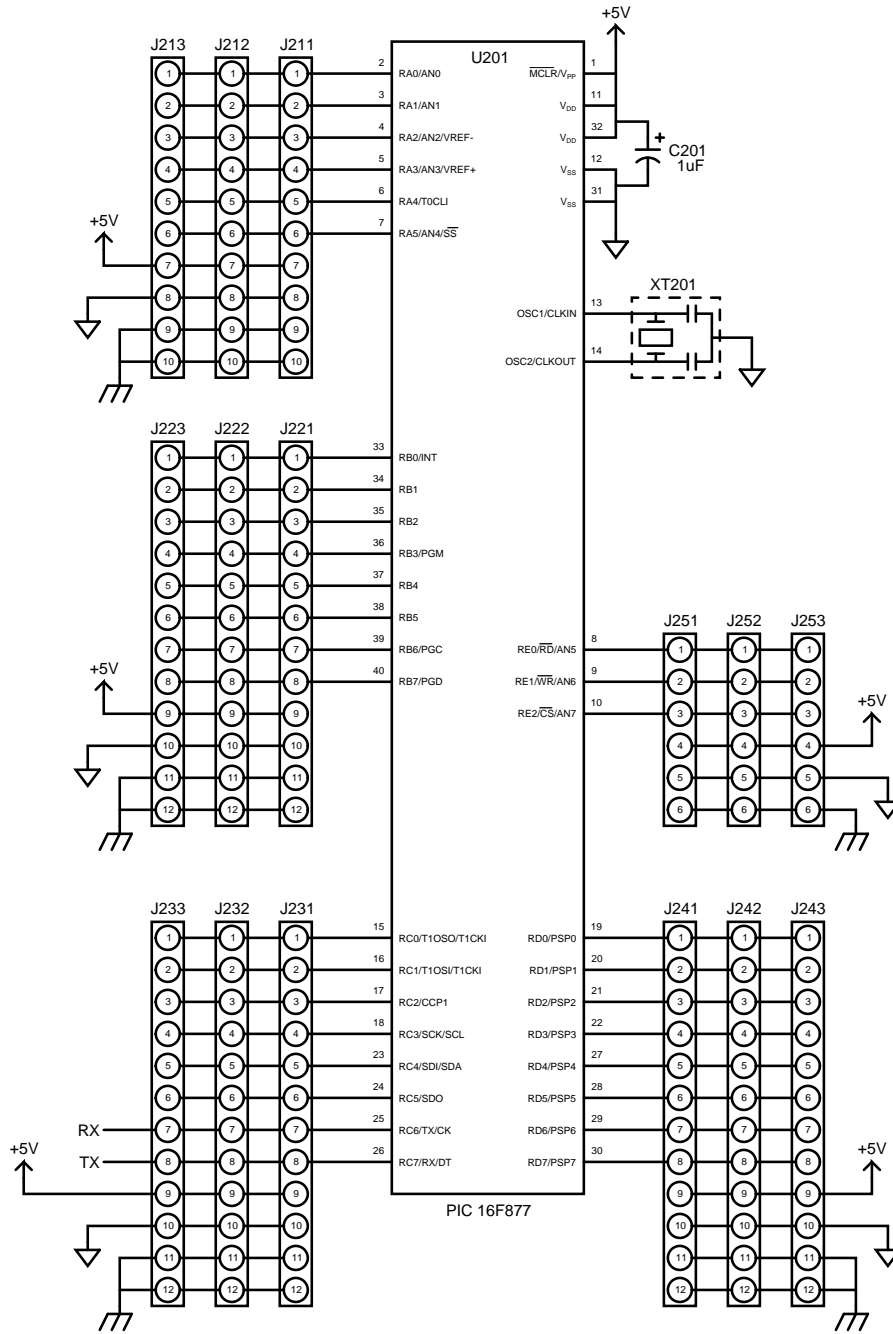

Figure 4: Supply Board component layout and bottom-side tracks.

## 6 PIC Board

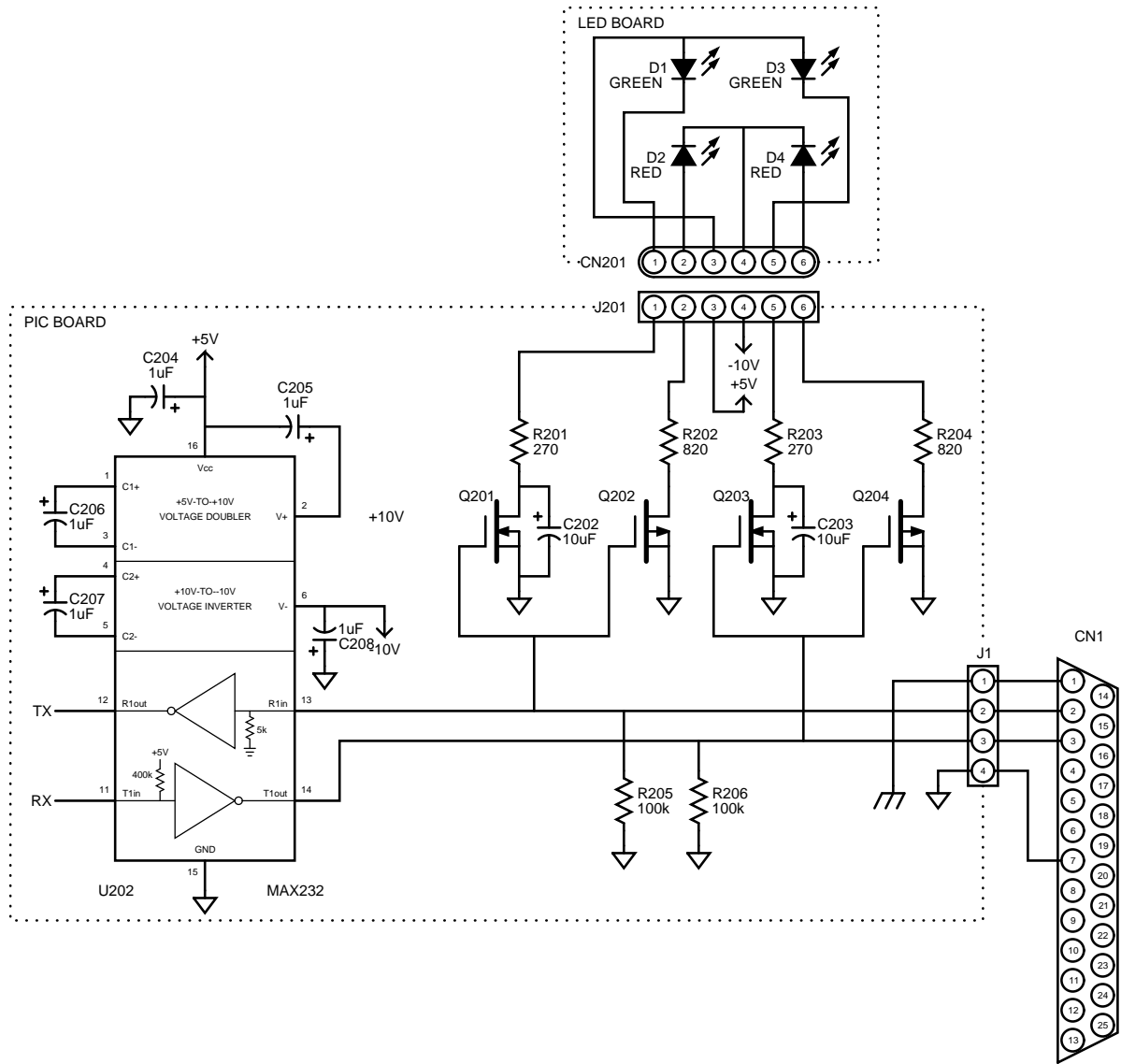

**Figure 5:** Circuit drawing for the PIC Board.

The PIC Board contains a PIC 16F877 in a 40-pin ZIF socket. Header connectors are provided for all signals to be connected to the PIC's input and output pins. A MAX232 RS-232 converter is also provided.

The main circuit schematic for this board is shown in Figure 5. The circuit schematic for the RS-232 section is shown in Figure 6 on the next page.





**Figure 6:** Circuit drawing of the RS-232 section of the PIC Board.

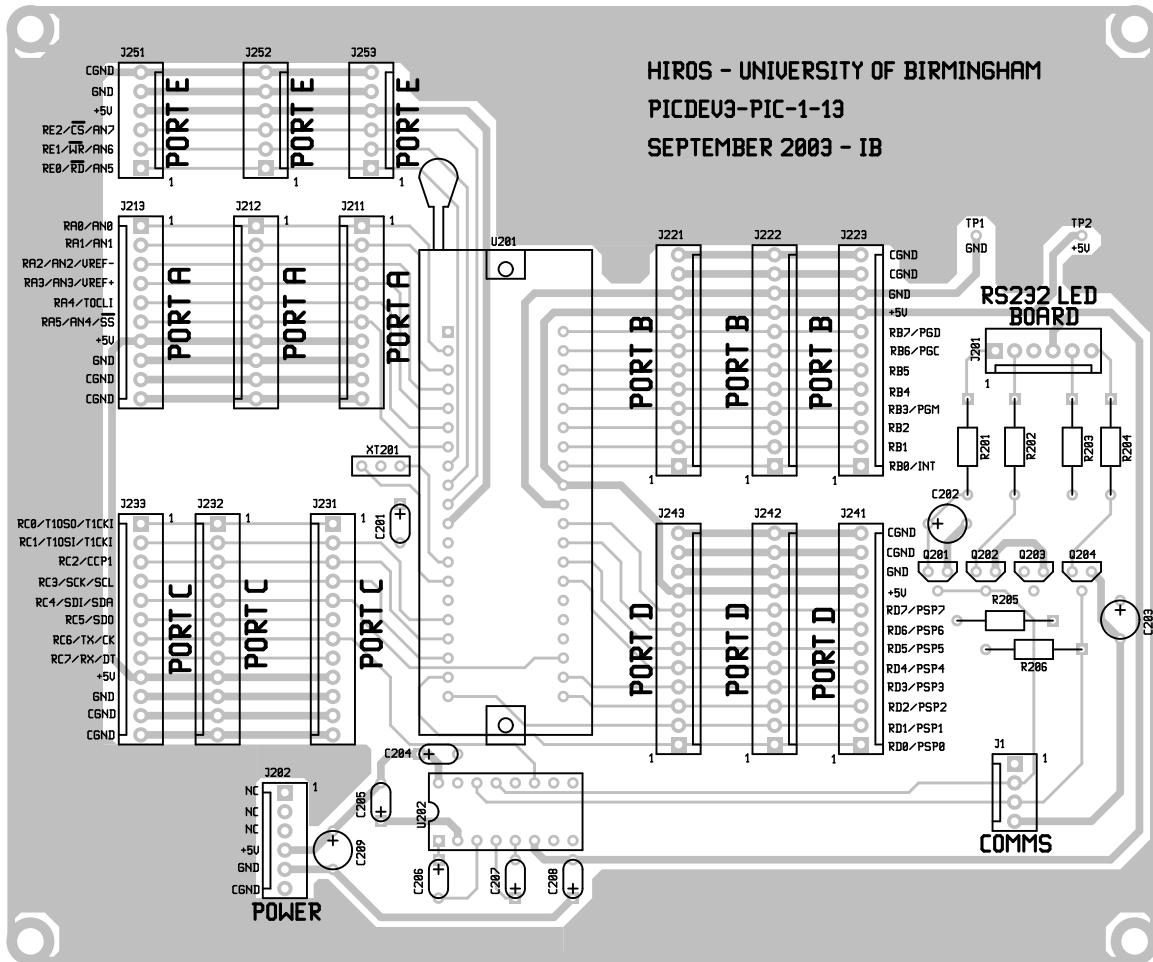

Figure 7: PIC Board component layout and bottom-side tracks.

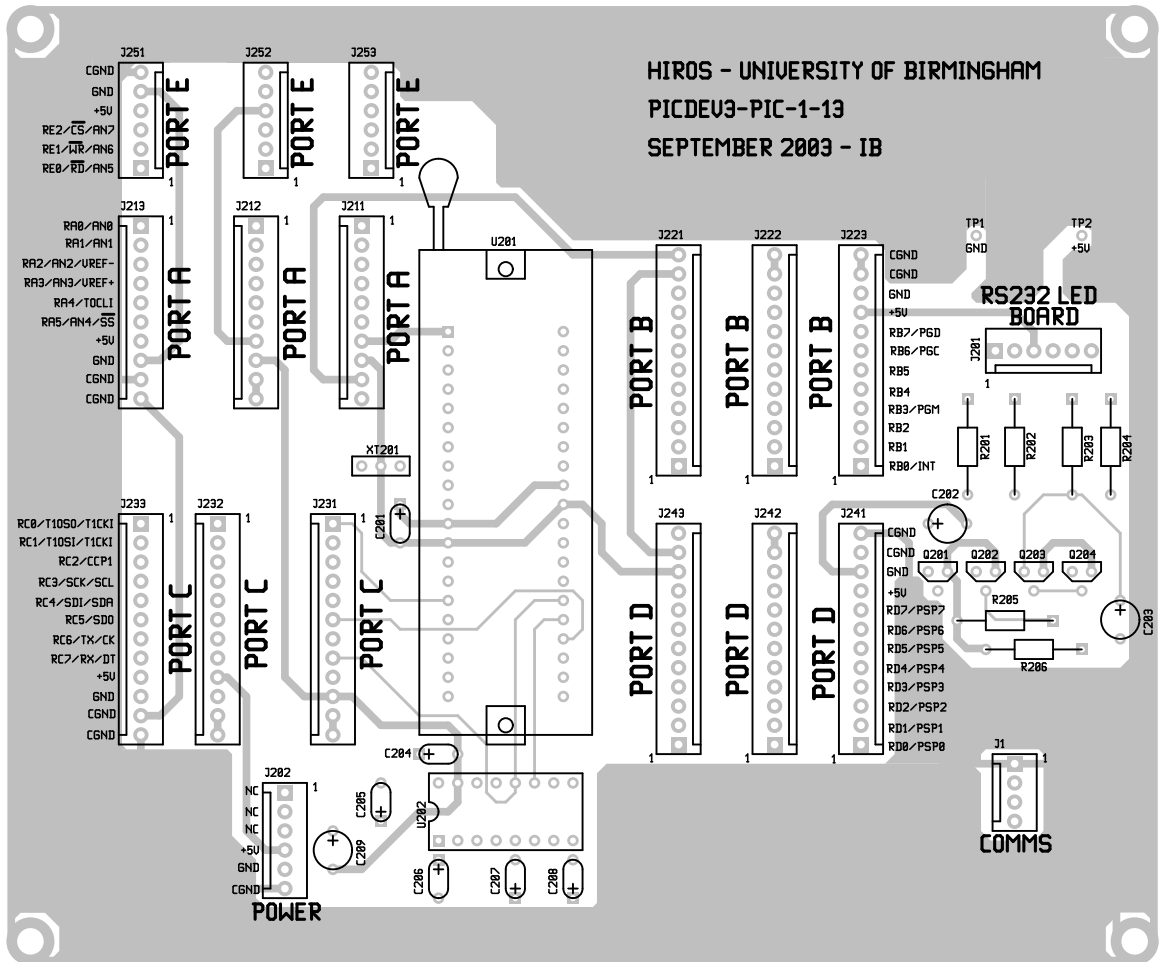

Figure 8: PIC Board component layout and top-side tracks.

## 7 RS-232 LED Board

The RS-232 LED Board contains four front-panel-mounted LEDs and displays the state of the RS-232 lines. The bottom side tracks and the component layout are shown in Figure 9.

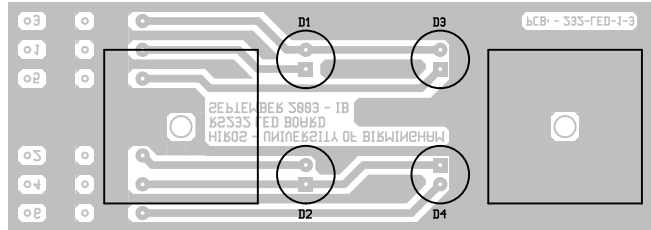

Figure 9: RS-232 LED Board component layout and bottom-side tracks.

## 8 Power LED Board

The Power LED Board contains three front-panel-mounted LEDs and displays the state of the power-supply lines. The bottom side tracks and the component layout are shown in Figure 10.

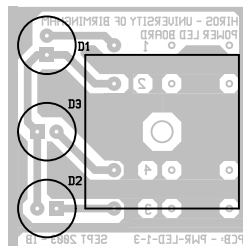

Figure 10: Power LED Board component layout and bottom-side tracks.

## 9 RS-232 Interface

The BeebSub communicates with the computer through an RS-232 connection. The connector for this link is at the far left on the rear panel. It is a 25-pin, female D-connector. The only pins used in this connector are: 1 (chassis ground), 2 (transmit data, TxD), 3 (receive data, RxD), and 7 (signal ground). The BeebSub is configured as data communications equipment (DCE) and transmits on pin 3 and receives on pin 2. The RS-232 settings are 9600 baud, 8 bits, no parity. No handshaking (hardware nor software) is provided.

Four LEDs on the front panel show the state of the TxD and RxD lines. The left column is for the TxD line and the right column is for the RxD line. The red LEDs on the bottom are illuminated when the corresponding line is low. The green LEDs on the top are illuminated when the line is high.

The BeebSub communicates with the computer using one-line messages. Each message begins with a dollar sign (“\$”, ASCII 36) and ends with a carriage-return/line-feed pair. The BeebSub will send an asterisk (“\*”, ASCII 42) followed by a two-character checksum at the end of each message.

The checksum is calculated by XORing the ASCII values of all of the characters in the message that follow the dollar and precede the asterisk. The dollar and asterisk are not included in the checksum calculation. The resulting checksum is included in the message as a two-character hexadecimal value.

The following messages are sent from the BeebSub to the computer.

## 9.1 Counter Data

`$C,<DIGIT-STRING>,<OVERFLOW>*<CK><CR><LF>`

`<DIGIT-STRING>` The string of hex digits read from the BBC scalars.

`<OVERFLOW>` Zero (“0”, ASCII 48) if all of the digits read from the BBC scalars are present in this message, or one (“1”, ASCII 49) if the BBC scalars returned more digits than would fit in this message. The BeebSub can buffer only 96 digits.

The BeebSub will send one counter-data message every time the BBC scalars raise the  $\overline{MT}$  line.

## 9.2 Error Message

`$E,<ERROR-CODE>,<DESCRIPTION>*<CK><CR><LF>`

`<ERROR-CODE>` A numeric error code.

`<DESCRIPTION>` A description of the error in text form for humans to read.

The BeebSub can send these two error messages:

```
$E,01,!MT stuck low*72
$E,02,!MT stuck high*0B
```

## 10 Parts List

A list of some of the components purchased in order to build the BeebSub are shown in Table 5. The pin-outs of some of the components is shown in Figure 11.

**Table 5:** Parts List

	<i>Manufacturer's Part Number</i>	<i>Description</i>	<i>Unit Cost</i>
C107,108	Rapid 11-0765	2,200- $\mu$ F 35-V 85°C electrolytic cap	0.275
CN8'	Rapid 22-2500	2-pin 0.156-in. female header	0.013
D101-108	Rapid 47-3144	1N5401 100-V rectifier diode	0.024
F101,102	Rapid 26-4614	0.9-A resettable fuse	0.26
J8	Rapid 22-2590	2-pin 0.156-in. header	0.036
Q101	Rapid 47-3290	L7805CV 1-A voltage regulator	0.145
Q102	Rapid 47-3300	L7915CV 1-A voltage regulator	0.155
Q103	Rapid 47-3294	L7815CV 1-A voltage regulator	0.145
Q201,203	Rapid 47-0156	ZVN2106A MOSFET	0.22
Q202,204	Rapid 47-0174	ZVP2106A MOSFET	0.29
U201	Rapid 73-3202	PIC16F877-04P dip40	3.90
U202	Rapid 82-0148	MAX232CPE RS-232 line driver dip16	1.18
XT201	Rapid 90-0625	4-MHz ceramic resonator	0.19
	RS 224-234	rack case 1 U $\times$ 84 HP $\times$ 254 mm	52.57
	RS 364-7185	IEC inlet filter	14.44
	Rapid 75-0330	DPST red visirocker switch	0.53
	Rapid 22-1580	40-pin ZIF socket	8.27
	Rapid 33-3525	M3-12 hex spacer pk25	1.62
	Rapid 33-4210	M3-6 s/s pan-head pk100	1.80
	Rapid 33-4260	M3-6 s/s csk pk100	1.70
	Rapid 88-2622	50-VA 18-V 1.39-A toroidal transf	6.38
	Rapid 36-0250	twisted-vain 9.9°C W <sup>-1</sup> TO-220 heatsink	0.38

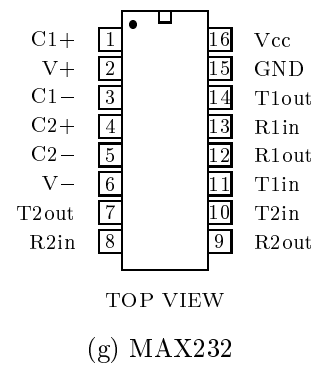
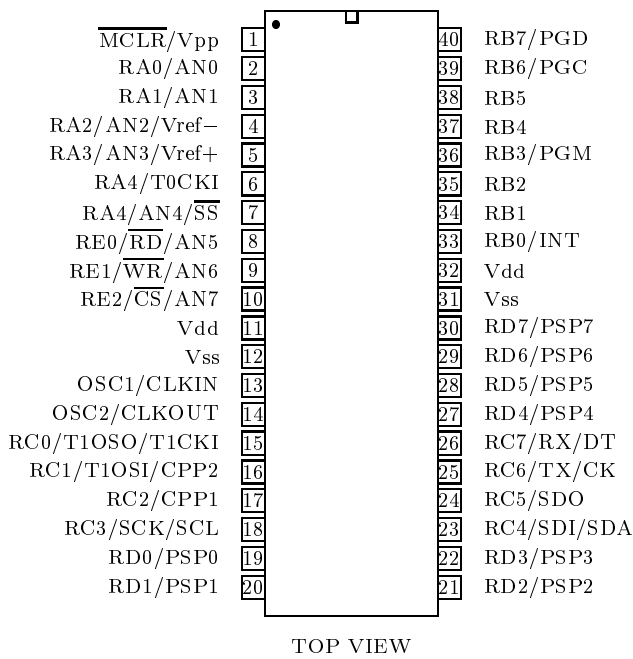
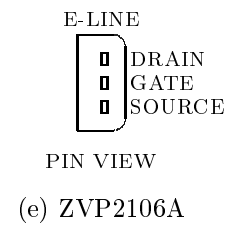
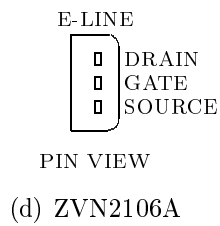
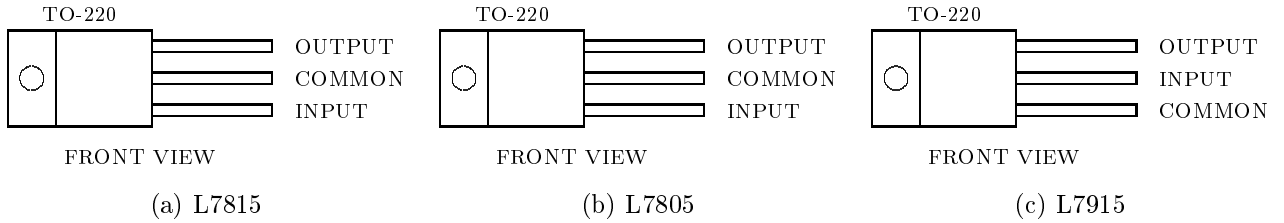

(f) PIC 16F877

**Figure 11:** Pin-outs of various components.

## References

- [1] CLIVE P. MCLEOD. Mark I scaler system. *BISON Technical Report Series*, Number 184, High-Resolution Optical-Spectroscopy Group, Birmingham, United Kingdom, July 2002.
- [2] IAN BARNES, BARRY JACKSON, AND BREK A. MILLER. Picdev #3 — A PIC development system. *BISON Technical Report Series*, Number 217, High-Resolution Optical-Spectroscopy Group, Birmingham, United Kingdom, November 2003.