

Saeed Hasanzadeh, Sadegh Vaez-Zadeh

A Review of Contactless Electrical Power Transfer: Applications, Challenges and Future Trends

DOI 10.7305/automatika.2015.12.727
UDK 621.3.051:[537.85+537-961]

Original scientific paper

Methods of contactless electrical power transfer technologies have been surveyed and results are presented here. In this among, the inductive based contactless electrical power transfer systems are investigated in more detail. The principles, structures and operations of the systems as well as their methods presented in the literature are reviewed and their applications are explored. Also, current challenges and opportunities and future trends are noted. An effective index is proposed to compare different contactless power transfer systems describing their present statuses and the future trends. Finally, some remarks and recommendations regarding future studies are proposed.

Key words: Contactless Electrical Power Transfer, Inductive Power Transfer, Resonant Circuits, Wireless Power Transfer

Pregled stanja u području bezkontaktnog prijenosa električne energije: primjene, izazovi i trendovi. U radu je dan prikaz različitih tehnologija u području bezkontaktnog prijenosa električne energije. U radu je naglasak na indukcijom baziranim sustavima bezkontaktnog prijenosa električne energije. Pregledom literature utvrđeni su koncepti, strukture i način rada pojedinih sustava bezkontaktnog prijenosa kao i njihove primjene. Također, zabilježeni su trenutni izazovi, prilike i trendovi. Predložen je efektivni indeks za vrednovanje sustava bezkontaktnog prijenosa električne energije s ciljem komparativne analize različitih sustava opisanih trenutnim statusom i trendovima. Konačno, dan je kritički osvrt i predložene su preporuke za buduće studije.

Ključne riječi: bezkontaktni prijenos električne energije, indukcijom bazirani prijenos energije, rezonantni krugovi, bežični prijenos električne energije

1 INTRODUCTION

The idea of electrical power transfer without mechanical contact, so-called wireless power transfer, was a human dream at early stages of the electrical power conversion where Nikola Tesla took the preliminary steps at the late nineteenth and early twentieth centuries [1-2]. It is almost a century that signals are transferred in long distances via electromagnetic waves for applications such as radio, television and communication systems. However, methods of wireless power transfer are much less developed due to the fact that the functional limitations and design considerations for power transfer systems are more demanding than those of the signal transfer systems [3]. In recent years, with the development of portable electronic equipment such as notebooks and cell phones, new demands for contactless power transfer have emerged and the research on this kind of power transfer has attracted more attentions.

Electromagnetic radiation based power transfer in short distances can be used to lighten fluorescent lamps with several watts. Many products have also been developed by

utilizing microwave power transfer methods. The process of converting sunlight into high frequency microwaves and transmitting them into the earth is also used [4]. The power of microwaves can also be efficiently transferred using lenses and reflection mirrors [5-6]. A major problem of this method is the conversion of power into usable power by the antennas. This problem is solved by introducing rectifier antennas, Rectenna, in 1963 [7]. An important application of wireless power transfer via microwaves was demonstrated through the space solar power program (SPS) in late 1970s [4]. The wireless power radiation can be used to transfer power to far destinations even up to several tens of kilometers. However, this system is more complex and its design and manufacturing are costly with respect to other wireless power transfer methods.

In recent years, inspiring by the concept of mutual induction and resonance phenomenon, inductive power transfer systems have been attractive as a re-emerging technology. These systems are composed of electromagnetic devices, control sub-systems and power electronics cir-

cuits. It is known that two resonant objects with the same resonance frequency have the most energy exchange. This fact leads to numerous studies on the performance evaluation of magnetic coupled resonators and their applications in magnetic systems [8].

Another contactless power transfer method for feeding moving objects is the capacitive method in which two separated capacitor plates shape a large air gap for power jump, referred as capacitive coupled power transfer (CCPT). Recent research on different aspects of CCPT include investigating the effects of system coupling variations, introducing different analysis methods, using series compensation systems for efficiency improvement and presenting different structures for device charging [9-12]. Although, a CCPT system has a simple concept compared with an inductive power transfer system, its required high electric field intensity higher than 30 kV/cm in the air results in some practical difficulties.

The main concern of this paper is to introduce the structure, operation modes, applications, current researches and future trends of inductive based contactless electrical power transfer (CEPT) systems. A schematic view of an inductive CEPT system is illustrated in Fig. 1 showing three system stages as:

- The electrical power is directly converted to high frequency electromagnetic power,
- Electromagnetic power is transferred from a transmitter to a receiver through free space,
- The received electromagnetic power is collected and converted to the electrical power in order to be used by a load.

Section 2 discusses the principles of the CEPT systems. In section 3 different applications of CEPT systems are presented. Current researches and challenges associated with the CEPT systems are investigated in section 4. The opportunities and future trends in the CEPT research are noted in section 5 by introducing an index, referred as “power distance index (PDI)”. Finally some concluding remarks and recommendations are given in section 6.

2 PRINCIPLES OF CEPT SYSTEMS

In order to attain a high efficiency in CEPT systems, the operating frequency must be reasonably high. As a consequence, a large power supply is required resulting in an increased circulating power. This in turn, reduces the transferred power. In brief, there is a conflict between a high efficiency and a high transferred power as a major drawback of CEPT systems. To overcome this problem, installing capacitive compensation in both primary and secondary sides is recommended to provide resonance conditions [3]. The power transfer capability of the CEPT system is enhanced

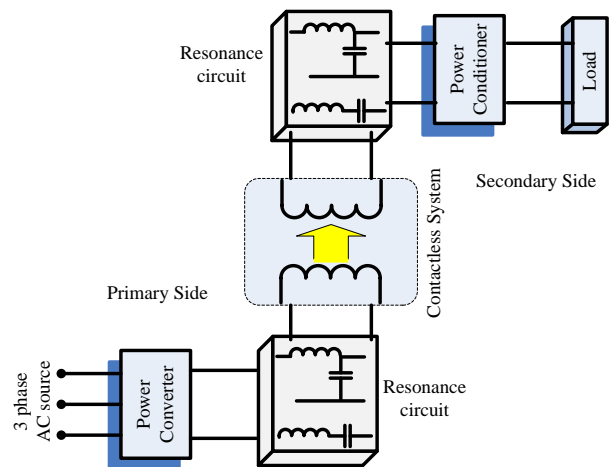

Fig. 1. Basic structure of a CEPT system

by the secondary compensation and the power rating of the source side is decreased by the primary compensation that ensure the power transfer at unity power factor.

2.1 Non-resonance Based CEPT

Wireless non-radiation power transfer between non-resonance objects is limited to low power (mW range) and short-distance (in comparison to the device dimensions) applications because of a strong deterioration of the produced field by the sender and its leakage (radiation losses) in the free space. The cost of this system is much less than that of the systems based on wireless power transfer in the far field radiation area. Some of these applications include wireless battery charger [13-15], coreless transformers [16] and wireless transfer systems for moving or rotating loads [17].

There are many patents in the field of wireless battery charger. The general characteristic of these devices are based on magnetic induction through a transmitter to a receiver. However, there are major differences in their geometry and topology which provide more capabilities depending on the application. Fig. 2 shows an example of a charger in which an array of windings is used in a transmitter for energy saving [14].

Nowadays, several wireless battery charger products are manufactured using magnetic induction.

2.2 Resonance Based CEPT

The contactless power transfer in non-radiation methods near field areas between resonance objects was introduced in 2007 [18]. It is described by the “strongly resonance coupled mode” theory [19]. A quantitative quasi-static model for the power transfer in non-radiation near field areas is also presented [8]. It is worth mentioning

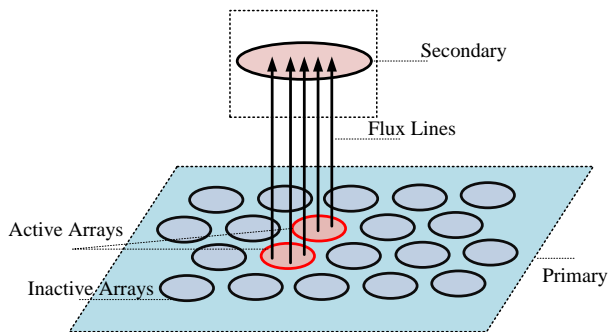

Fig. 2. An array of windings in a transmitter for energy saving [14]

that the simulation results obtained from this model match the experimental results with an error up to 5%. The research reaches an efficiency of 40% within 2 m distance. Non-radiation contactless power transfer between resonant objects can be used in the case of longer distances in comparison with non-resonant cases. This is due to a greater coupling coefficient of the resonant objects. Another experimental study is reported with an efficiency of up to 75% within 90 cm distance [20].

A set of equations governing “strong coupling mode” is presented showing that the efficiency of power transfer can be improved significantly using one or more resonators [21]. Also, a resonant magnetic coupling system is modeled and analyzed [22-23]. More recently, comparative resonance and non-resonance based magnetic coupling systems applied to wireless charging are presented that show the efficiency of the resonance based method is much higher than non-resonance method [24-25].

3 APPLICATIONS OF CONTACTLESS ELECTRICAL POWER TRANSFER

CEPT systems have advantages in some applications, especially in the case of large air gaps in which power reaches the moving or rotating loads. Major of CEPT applications are reviewed in this section.

3.1 Biomedical applications

In some cases, it is essential that electronic devices to be implanted within the patient’s body. Feeding these systems can be provided by internal batteries and external sources. In later cases wires may be uncomfortable for patients with movement limitations and sometimes may cause serious infections. Also, batteries have disadvantages such as being heavy, massive and costly, containing harmful toxic substances and requiring surgery for implementation [26-27]. Many studies have been carried out to

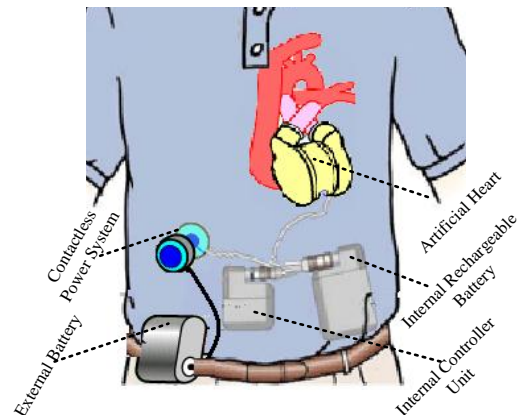

Fig. 3. A coupled contactless power supply for an artificial heart

utilize CEPT technology in these cases. Some developments can be mentioned as follows: power transfer for the pressure display, neural simulation devise, temperature measurement, heart rate regulatory systems [28-30] and wireless feeding endoscopy capsule for diagnosing the path of human intestine [31]. Recently, power transfer is provided by resonance based methods with power electronic tools [32-35].

Fig. 3 illustrates a typical contactless power supply configuration for an artificial heart. The primary coil is placed outside a patient’s body. The secondary coil is implanted under the skin, facing the primary coil. Typically, the coupling coefficient of such a system is within the range of 0.1– 0.3 and the distance between the external and internal coils is less than 3 cm [36].

3.2 Household Apparatuses

Household tools without electrical connections have more flexibility and controllability in addition to a better appearance. Examples of these instruments include coffee machines, shaving machines, electrical toothbrushes, etc. Inherent insulation between supply and human body increases the safety of applicants. Charging laptop computers [37-38], mobile batteries [39-40] and other electrical devises [41] without the use of wires show the convenience and attractiveness of this technology. Fig. 4 shows, as an example, a schematic view of a wireless power transfer system supplying a television [42].

3.3 Rotating Applications

In applications such as radar and wind turbines, it is required to transfer power through rotating interfaces. In these cases, utilization of wires is impossible because of the continuous rotation which may twist and pull the wires

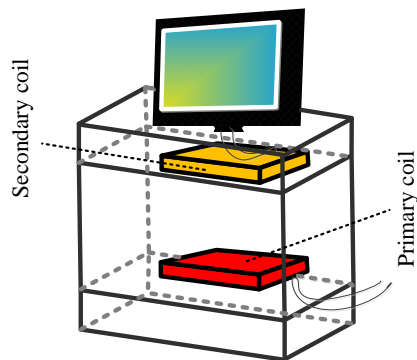

Fig. 4. Wireless power transfer used to supply a TV [42]

and cause fault in the systems. Hence, brushes are used which increase losses and maintenance cost [43]. As a solution, CEPT is used to transfer the power to rotary loads [44]. Also, electrical connections are not suitable for supplying professional tools such as drill machines in harsh conditions [45] and magnetics micromachine [46]. Similarly, using contactless power transfer is useful where the explosion hazards exist like in mines.

3.4 Electric Vehicles

Electric vehicles (EVs) for long distance travels need massive batteries with long periods of charging. Contactless power transfer is a suitable solution for recharging the EV batteries and reducing their weight and size. In recent years, the idea of using a coupling system for providing propulsion power to electric vehicles has gained increased attention [47-51, 106]. A power electronic power transfer system for charging an electric vehicle is depicted in Fig. 5 [52]. Recently a wireless charging system has been presented for vehicle charging in motion as shown in Fig. 6 [107].

3.5 Transportation Systems

Power transfer to moving objects often is regarded as an essential limitation for rapid transports. Therefore, replacing permanent connections such as stretching cables, brushes and pantographs seems necessary especially at high speeds. Also, the use of contactless power transfer systems is more useful considering economic and reliability aspects of a system [53-55]. A transport system with a low air gap (10mm) and a high power (2.5 MW) characteristic is presented with the frequency of 18 kHz [56]. An inductive power transfer to a monorail system [57] and a CEPT system for a linear machine [58] are also proposed. A new technology is employed for high speed Maglev trains in Switzerland metro [59].

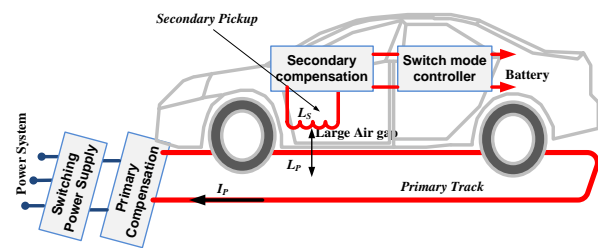

Fig. 5. A CEPT system in an electric vehicle application [52]



Fig. 6. In motion wireless charging system for electric vehicle application "used with permission of ORNL" [107]

4 CURRENT CHALLENGES

The research on CEPT systems has increasingly been considered in the last decade. Many researches have been carried out in different centers and institutes dealing with power electronic converters and related control concepts, topologies and structures and also resonance and frequency issues. These researches cover several applications including extra high speed transportation systems, medical and low power applications and electric power transfer for greater distances than the dimensions of primary and secondary systems. These studies are categorized as follows:

4.1 Architectures and Structures

A long distance between the primary and secondary coils in contactless transfer systems increases the magnetizing current and the leakage magnetic flux, thus deteriorating the system efficiency. The initial solution for this

problem is a modification of the topology and the structure of power transfer systems. It is notable that the configuration and the structure of power transfer systems are usually determined by their applications. Also, the air gap and the power transfer rate are important factors for determining the system configuration and structure. Selecting an appropriate structure leads to an optimum transfer of magnetic flux from the primary to the secondary coils of the system. Many researches have been tried to select appropriate topologies and structures for CEPT systems, some of them are reviewed in this section.

A coaxial CEPT structure based on long fixed primary and movable secondary systems as a power supply for Maglev applications is proposed and analyzed. A 3D FEM analysis of the structure is illustrated in Fig. 7 [61]. A prototype of a multi-phase pick-up coil suited for capturing both vertical and horizontal components of a magnetic field around any inductive power transfer (IPT) track is proposed for vehicle applications [62-63]. Also, a motion system consisting of a contactless planar actuator with six degree of freedom (6-DOF) is presented [64]. To provide contactless power to a moving vehicle, a long fixed primary winding inductively coupled to a moving secondary winding is presented [65]. A configuration consisting of a C-shape and an I-shape cores are also proposed for battery charging purpose [66]. Effects of core structures and coil arrangements on improving transformer coupling coefficient, size and weight of CEPT systems are discussed [67]. Poly-phase inductive power transfer systems are proposed for increasing the tolerance of roadway-based vehicular systems to the lateral movement of pickup coils [68-70].

A single-layer winding array structure with cylindrical ferrite cores is presented for planar contactless battery charging systems [71]. Also, two rectangular-shape contactless power supply system are presented with a high coupling coefficient for a large air gap [72-73]. A Circular magnetic structure and a polarized coupler topology are proposed providing a wide charge zone for pads [74-75]. The charging platform including several pot type cores with an array structure and a square planar spiral structure are proposed [76]. A three-coil inductive power transfer link is introduced to improve the efficiency for implantable devices [77].

4.2 Frequency and Resonance Issues

Operating frequency is an important factor in power transfer systems. A higher frequency of power signal causes a higher overall efficiency of the system. Generating high frequency power signals is difficult due to semiconductor restrictions. Also, the radiation loss may cause some problems in the high frequency operation of the sys-

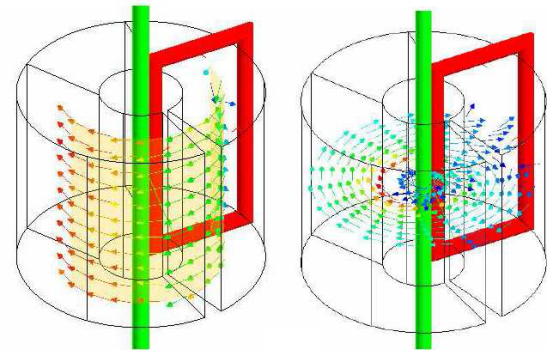

Fig. 7. 3D FEM analysis of a CEPT structure for Maglev application [61]

tem. Magnetizing current and leakage fluxes are also related to frequency.

Compensators such as capacitors in the system primary and secondary improve the efficiency of the system. Compensating capacitors also improve the power factor by reducing the magnetizing current. Also, the utilization of appropriate capacitors in primary and secondary systems creates a resonance circuit with the winding inductance [108]. A magnetic coupled resonator includes at least two resonance circuits that can exchange their energy in the same resonance frequencies while not affecting the non-resonance objects surrounding them. In fact, a resonance tunnel is established between the resonance coils [8]. Many efforts have been done to enhance the performance of CEPT systems by resonance phenomenon and adequate operating frequency. A resonance frequency of 134 kHz with an E class converter provides 69 W contactless power transfer to a load with 74% efficiency [78]. A series loaded series resonant (SLSR) converter with a magnetic link provides maximum efficiency based on a resonance frequency of 90 kHz [79]. Wireless power transfer via magnetic resonant coupling is experimentally demonstrated in a system with a large source coil and either one or two small receivers with 8.3 MHz resonant frequency [80]. The modeling and experimental evaluation of a coupled magnetic resonance are presented with a high distance between the receiver and the transmitter and the resonance frequency more than 10 MHz [81-83]. A variable coupling technique for achieving a high efficiency in a resonance coupled wireless power transfer system at every air gap length is achieved by adjusting the resonance frequency [84-85]. An equivalent circuit model is employed to analyze a CEPT system with resonance frequency of 3.7 MHz [86]. Relay resonators are spaced between the transmitter coil and the receiver coil for maximizing power efficiency and increasing the overall transfer distance between the

power source and the load [87]. It is shown that, in CEPT systems, antiparallel resonant loops can provide improved efficiency [88]. The mixed-resonant coupling model is proposed for a wireless power transfer system improving the efficiency for long distances [89]. It is demonstrated that using a magneto-plated wire instead of copper wire at frequency of 12 MHz reduces skin effect as well as AC resistance and increases the efficiency up to 7.9% in a wireless power transfer system with transfer distance of 10 mm [90]. Overall efficiency and coupling coefficients of different compensated structures are modeled and analyzed for a long primary track in maglev applications [91]. Also, an algorithm to obtain optimum resonance frequency in terms of CEPT system parameters is proposed [92].

4.3 Power Electronics and Control

Control methods are investigated in many researches. Power electronic topology and the method of creating power signals, in addition to resonance convertor issues are investigated. A 3 kW power electronic resonant converter is presented with IGBT switches and FPGA control for a rotatable transformer application [93]. A resonant converter with zero-current switching (ZCS) is presented to decrease switching losses [94-95]. Also, a power electronic control located in the pickup side to tune resonance circuit is designed [96]. Unity power factor pickup is developed using a series-parallel-tuned LCL circuit [97]. A 1.2-kW series ac-processing pickup topology is built which can control the output power over a wide range of loads [98]. In some cases, power conditioners for primary side are proposed [99]. Current sourced bi-directional power interfaces are applied to CEPT systems by parallel capacitor compensation with controlled rectifiers on both sides of a system [100-102]. A direct ac-ac converter is suggested for CEPT systems which can generate a 30 kHz current directly from a 50Hz power supply [103]. A control method based on quantum modulation is presented for a resonant converter topology [104].

5 OPPORTUNITIES & TRENDS

Concurrently with using electrical power, Tesla dealt with wireless electrical power transfer in the late nineteenth century. However, his dreams remained impractical. In the late twentieth century, with the development of portable electronic devices, once more, applications of contactless power transfer systems gained momentum. Also, extra high speed transportation encourages the high voltages contactless power transfer.

Here, in order to compare and examine the process of technological growth in this field, an index is defined as the product of transferred power and distance; referred as power distance index (PDI), $PDI = P_t \times D$. It is introduced due to the fact that in a CEPT system, as the

distance increases the power transfer becomes more difficult. Nowadays, lower powers are transferred in higher distances and high powers can be transferred in short distances. Researchers hope that future progresses provide the opportunity of transferring high powers in long distance at a suitable efficiency. Therefore, previous developments are classified by using PDI.

The higher the PDI figure represents the more advanced the technology. In Fig. 8, the examined studies are categorized and their PDIs are shown in terms of the transfer efficiency. According to this figure, for applications in which the PDI is required to be high, the contactless power transfer is more challenging. The dream of Tesla can be fulfilled by high values of the index at the long time ahead. As far as different applications are concerned, between 1995 and 2005, the value of PDI was in the range of 0.1 Wm for cellphone charging to several kWm for various industrial applications. Considering the conducted research on this issue, the value of PDI has increased in the first decade of the new millennium [18].

Although the eventual dream of all applicants is to reach higher PDI values with higher efficiencies, the associated costs limit the development trends in special directions. It is seen that PDI values for some applications including industrial, commercial and biomedical is relatively constant and near future trend in these applications is to enhance the efficiency at reasonable prices. Automotive applications such as EV charging currently have high efficiency and the future trend is to approach high PDI values. In high speed trains where the cost is less restricted, increasing both PDI and efficiency will be considered in the future. The trend for each technology is shown by an arrow in Fig. 8.

In some applications such as commercial, industrial, biomedical and high speed trains, the distance is specified and efficiency improvement is the main concern. Recent investigations focus on increasing PDI, while maintaining the efficiency at high levels as in Fig. 8 [18, 20]. The development process of CEPT technology is depicted in Fig. 9 for a wide time span. It is observed that the idea of power transfer started by a big dream. Then, in the first decade of the twenty-first century, it was steadily improved.

Using relationships of the CPT presented in [105] and three-dimensional finite element method, the efficiency and PDI as functions of air gap to coil diameter (L/D) are calculated for different frequencies as shown in Fig. 10. The sender coil diameter is kept constant in simulations. The air gap is then varies and the receiver coil diameter is tuned to have a maximum efficiency. It is observed that higher efficiencies are achieved in higher frequencies. Also, the efficiency decreases as the L/D ratio increases. It is predicted that researches will tend to gain a higher efficiency in a larger L/D ratio indicated as zone 1 in Fig. 10.

The normalized PDI significantly reduces in regions with L/D lower than 0.5 and higher than 1.75 indicated as zone 2 and zone 3 respectively. Future investigations will try to fill these gaps using advanced methods such as orientation of flux path from primary to secondary, advance materials for receiver and sender sub-systems, using materials with a high permeability and a low conductivity in transmission region, etc.

In near future, the market of electric vehicles will boom considering the high cost of fossil energies, attention to environmental protection and production of more electrical power using the nuclear power. Then, the requirement for applying contactless power transfer systems will be more evident in order to supply accessible and reliable charging systems in shortest time periods. In addition, development of new technologies in building and building management systems (BMS) increases the need for contactless power transfer technologies with the capability of simultaneous power and command control. It seems that CEPT systems can contribute to social life style and building management methods. Along with the growth of technology, rapid growth of power transfer networks towards smart grids whether in terms of network control in initial stages or in terms of changing the structure of networks, at least at the distribution level (cordless distribution network), are predictable. Moreover, it can be predicted that, in the not-so-distant future, technology development may make it possible to reach Tesla’s dream in “contactless power transfer” in long distances.

6 CONCLUSIONS AND RECOMMENDATIONS

This review successfully compiled survey results of recent studies carried out on contactless power transfer technologies, emphasizing their importance and necessity along with the corresponding methods and characteristics of related systems. It is also aimed at comparing the advantages of the systems and some of their implementation strategies. Different applications of the systems are pointed out including rotating devices, medical implants, battery chargers of electric vehicles and rapid transit systems, household apparatus, etc.

An effective index (PDI) is proposed to compare different contactless power transfer systems and to describe their present statuses and the future trends. The development of CEPT systems has many challenges in its theoretical aspects, technical implementations and social and economic studies. The desirable performance of a contactless transfer system essentially depends on its power electronics and control sub-sections. Theoretical problems are comprised of power electronics, electromagnetics and control studies. In addition, there are many technical limitations in the design of CEPT systems. The maximum voltage and current

and switching frequency of the power semiconductors are among the main restrictions of the systems.

Although, it is now more than two decades that the price of semiconductors has decreased, the installation cost of CEPT systems is still much more than that of conventional supplies. The maximum efficiency of CEPT systems is significantly less than that of the common conductive power transfer systems. Also, it is essential that a practical design of CEPT systems is compatible with environmental and electromagnetic interference (EMI) considerations. Regarding previous studies and researches, the following questions have not been answered yet and are expected to be addressed in near future:

- 1- Is the available theoretical framework for analyzing and evaluating electromagnetic systems sufficiently capable of handling the contactless transfer of electrical power or it needs improvements?
- 2- Do the CEPT characteristics beyond those of usual electromagnetic systems, e.g. electrical machines and transformers- contain specific phenomena and conditions?

Much work is needed to answer these questions.

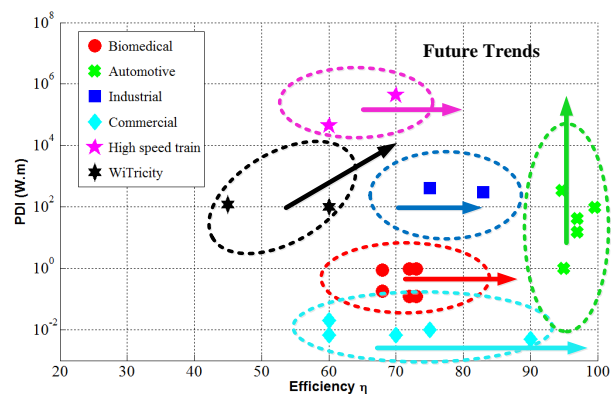

Fig. 8. PDI versus efficiency for CEPTs

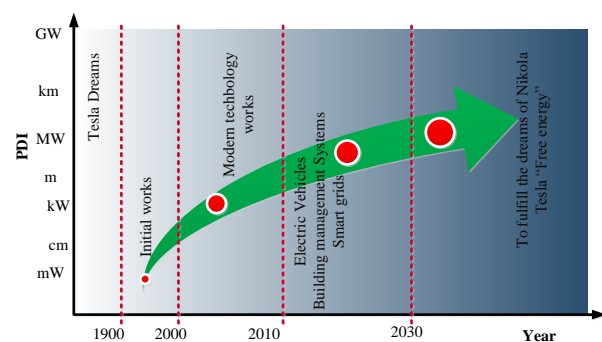

Fig. 9. Trends in development of CEPTs

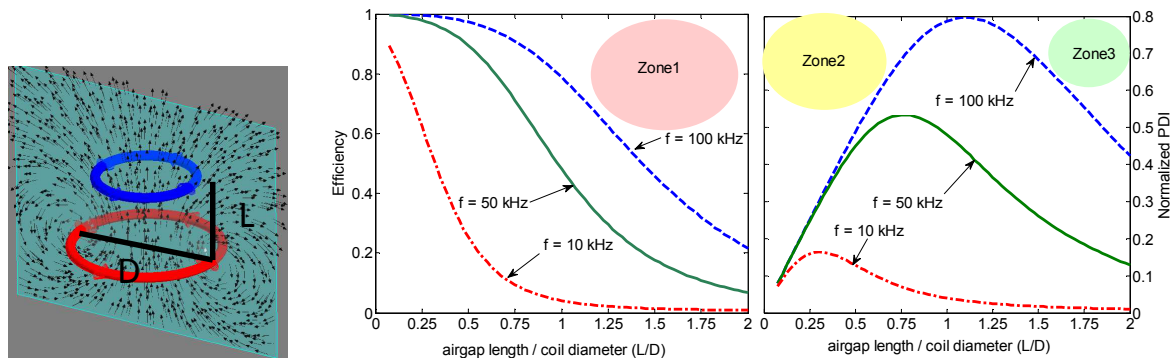

Fig. 10. Efficiency and PDI for different frequencies as a function of air gap to coil diameter

ACKNOWLEDGMENT

This work was supported by grants from the Iran National Science Foundation (INSF).

REFERENCES

REFERENCES

- [1] N. Tesla, "System of transmission of electrical energy," US patent number 645,576, March 1900.
- [2] N. Tesla, "Apparatus for transmitting electrical energy," US patent number 1,119,732, December 1914.
- [3] A. P. Hu, "Selected resonant converters for IPT power supplies", PhD thesis, University of Auckland, New Zealand, October 2001. (thesis)
- [4] J. O. McSpadden, and J. C. Mankins, "Space solar power programs and microwave wireless power transmission technology", *IEEE Microwave Magazine*, pp.46-57, Dec. 2002.
- [5] G. Goubau and F. Schwing "On the guided propagation of electromagnetic wave beams," *IRE Trans. Antennas Propagate.*, vol. AP-9, pp. 248-256, May 1961.
- [6] J. Degenford, W. Sirkis and W. Steier, "The reflecting beam waveguide," *IEEE Trans Microwave Theory Tech.*, pp. 445-453, July 1964.
- [7] R. H. George and E. M. Sabbagh, "An efficient means of converting microwave energy to DC using semiconductor diodes," *IEEE Intern. Conv. Rec., Electron Devices, Microwave Theory Tech.*, vol. 11, pt. 3, pp. 132-141, Mar. 1963.
- [8] Aristeidis Karalis a, J.D. Joannopoulos , Marin Soljačić, "Efficient wireless non-radiative mid-range energy transfer", *Elsevier Annals of Physics* 323, pp. 34-48 .
- [9] C. Iio, A. P. Hu, "Effect of series tuning inductor position on power transfer capability of CCPT system," *Electronics Letters*, vol. 47, pp. 136 - 137, 2011.
- [10] C. Liu, A. P. Hu, N. Nair, "Modelling and analysis of a capacitively coupled contactless power transfer system," *IET Power Electronics*, vol. 4, pp. 808 - 815, 2011.
- [11] M. Kline, "Capacitive power transfer", Technical Report No. UCB/EECS-2010-155. University of California at Berkeley, 2010.
- [12] C. Liu, A. P. Hu, N. Nair, "A capacitively coupled contactless matrix charging platform with soft switched transformer control," *IEEE Trans. On Industrial Electronics*, vol. 60, no.1, pp. 249-260, 2013.
- [13] J. Hirai, T.-W. Kim, A. Kawamura, "Study on intelligent battery charging using inductive transmission of power and information," *IEEE Trans. Power Electronics*, vol. 15, pp. 335-345, 2000.
- [14] J. M. Fernandez and J. A. Borrás, "Contactless battery charger with wireless control link," US Patent number 6,184,651, Feb. 2001.
- [15] L. Ka-Lai, J. W. Hay and P. G. W. Beart, "Contact-less Power Transfer," US Patent number 7,042,196, May 2006.
- [16] S. Tang, S. Hui, H. Chung, "Characterization of coreless printed circuit board (PCB) transformers," *IEEE Trans. on Power Electronics*, vol.15, no. 6, pp. 1275 - 1282, 2000.
- [17] G. Scheibe, B. Smailus, M. Klaus, K. Garrels and L. Heinmann, "System for wirelessly supplying a large number of actuators of a machine with electrical power," US Patent number 6,597,076, July 2003.
- [18] A. Kurs, A. Karalis, R. Moffatt, J. D. Joannopoulos, P. Fisher, and M. Soljačić, "Wireless power transfer via strongly coupled magnetic resonances," *Science Mag.*, vol. 317, no. 5834, pp. 83-86, June 2007.
- [19] H.A. Haus, *Waves and Fields in Optoelectronics*, Prentice-Hall, New Jersey, 1984.
- [20] "Intel imagines wireless power for your laptop," TG Daily. 2008-08-22. Retrieved 2009-06-04.
- [21] F. Zhang, S. A. Hackworth, W. Fu, C. Li, Z. Mao, and M. Sun, "Relay effect of wireless power transfer using strongly coupled magnetic resonances," *IEEE Trans. on Magnetics*, vol. 47, no. 5, pp. 1478-1481, 2011.
- [22] J. Wang, S. L. Ho, W. Fu, C. T. Kit, and M. Sun, "Finite-Element analysis and corresponding experiments of resonant energy transfer for wireless transmission devices," *IEEE Trans. on Magnetics*, vol. 47, no. 5, pp. 1074-1077, 2011.

- [23] J. Wang, S. Ho, W. Fu, and M. Sun, "Analytical design study of a novel witrlicity charger with lateral and angular misalignments for efficient wireless energy transmission," *IEEE Trans. on Magnetics*, vol. 47, no. 10, pp. 2616–2619, 2011.
- [24] S. L. Ho, J. Wang, W. N. Fu, and M. Sun, "A comparative study between novel witrlicity and traditional inductive magnetic coupling in wireless charging," *IEEE Trans. on Magnetics*, vol. 47, no. 5, pp. 1522–1525, 2011.
- [25] J. Wang, S. Ho, W. Fu, and M. Sun, "FEM simulations and experiments for the advanced witrlicity charger with compound nano-tio2 interlayers," *IEEE Trans. on Magnetics*, vol. 47, no. 10, pp. 4449–4452, 2011.
- [26] H. Matsuki, "Energy transfer system utilizing amorphous wires for implantable medical devices," *IEEE Trans. on Magnetics*, vol. 31, no. 2, pp. 1276–1282, 1995.
- [27] Z. Yang, W. Liu, and E. Basham, "Inductor modeling in wireless links for implantable electronics," *IEEE Trans. on Magnetics*, vol. 43, no. 10, pp. 3851–3860, 2007.
- [28] W. Guoxing, L. Wentai, M. Sivaprakasam, G.A. Kendir, "Design and analysis of adaptive transcuteaneous power telemetry for biomedical implants," *IEEE Trans. on Circuits and Systems I: Regular Papers*, vol. 52, No. 10, pp.2109 – 2117, 2005.
- [29] H. Matsuki, Y. Yamakata, N. Chubachi, S. I. Nitta, and H. Hashimoto, "Transcutaneous DC-DC converter for totally implantable artificial heart using synchronous rectifier," *IEEE Trans. on Magnetics*, vol. 32, no. 5, pp. 5118–5120, 1996.
- [30] S. Arai, H. Miura, and F. Sato, "Examination of circuit parameters for stable high efficiency TETS for artificial hearts," *IEEE Trans. on Magnetics*, vol. 41, no. 10, pp. 4170–4172, 2005.
- [31] G. Iddan, G. Meron, A. Glukhovsky, et al. "Wireless capsule endoscopy", *Nature*, 2000, 405:417
- [32] T. Sato, F. Sato, and H. Matsuki, "New functional electrical system using magnetic coils for power transmission and control signal detection," *IEEE Trans. on Magnetics*, vol. 37, no. 4, pp. 2925–2928, 2001.
- [33] A.K. RamRakhyani, S. Mirabbasi, C. Mu, "Design and optimization of resonance-based efficient wireless power delivery systems for biomedical implants," *IEEE Trans. On Biomedical Circuits and Systems*, vol.5, pp. 48 - 63, 2011.
- [34] Y. Wang, M. Dongsheng Ma, "Design of integrated dual-loop delta-sigma modulated switching power converter for adaptive wireless powering in biomedical implants," *IEEE Trans. On Industrial Electronics*, vol. 58, no. 9, pp.4241-4249, 2011.
- [35] L. Xiao, N. Shuangxia, S.L. Ho, W. N. Fu, "A design method of magnetically resonating wireless power delivery systems for bio-implantable devices," *IEEE Trans. on Magnetics*, vol. 47, No. 10, pp. 3833 - 3836, 2011.
- [36] Si Ping, A.P. Hu, S. Malpas, D. Budgett, "A frequency control method for regulating wireless power to implantable devices", *IEEE Trans. on Biomedical Circuits and Systems*, vol. 2, No. 1, pp.22 – 29, March 2008.
- [37] Y. Ota, T. Takura, F. Sato, H. Matsuki, T. Sato, T. Nonaka, "Impedance matching method about multiple contactless power feeding system for portable electronic devices," *IEEE Trans. on Magnetics*, vol. 47 , no. 10, pp. 4235 - 4237, 2011.
- [38] P. Meyer, P. Germano, M. Markovic, Y. Perriard, "Design of a contactless energy-transfer system for desktop peripherals," *IEEE Trans. on Industry Applications*, vol. 47, no. 4, pp. 1643 - 1651, 2011.
- [39] C. Panchal and J. W. Lu, "High Frequency Planar Transformer (HFPT) for Universal Contact-Less Battery Charging Platform," *IEEE Trans. on Magnetics*, vol. 47, no. 10, pp. 2764–2767, 2011.
- [40] K. Chang-Gyun, S. Dong-Hyun, Y. Jung-Sik, P. Jong-Hu, B.H. Cho, "Design of a contactless battery charger for cellular phone," *IEEE Trans. on Industrial Electronics*, vol. 48 , no. 6, pp. 1238 - 1247 , 2011.
- [41] D. Schneider, "Wireless power at a distance is still far away [Electrons Unplugged]," *IEEE Spectrum*, vol. 47, no. 5, pp. 34 - 39, 2010.
- [42] <http://presscentre.sony.eu/content/detail.aspx?NewsAreaId=2\&ReleaseID=4993>
- [43] B.A. Potter, S.A. Shirsavar, "Design, implementation and characterizations of a contactless power transfer system for rotating applications", *32nd Annual Conference on IEEE Industrial Electronics, IECON 2006*, pp.2168 – 2173.
- [44] M. Reinhard, C. Spindler, T. Schuer, V. Birk, J. Denk, "New approaches for contactless power transmission systems integrated in PM motor drives transferring electrical energy to rotating loads," *European Conf. on Power Electronics and Applications*, 2011, pp. 1-10.
- [45] Thierry Bieler, Marc Perrottet, Valérie Nguyen, and Yves Perriard, "Contactless power and information transmission" *IEEE Trans. on Industry Applications*, vol. 38, no. 5, 2002.
- [46] A. Yamazaki and M. Sendoh, "Wireless magnetic micro-machine of planar structure with magnetic thin film," *IEEE Trans. on Magnetics*, vol. 41, no. 10, pp. 4021-4023, 2005.
- [47] C. Wang, O.H. Stielau, G.A. Covic, "Design considerations for a contactless electric vehicle battery charger", *IEEE Trans. on Industrial Electronics*, vol. 52, no.5, pp.1308 – 1314, 2005.
- [48] J. Sallan, J. L. Villa, A. Llombart, J. F. Sanz, "Optimal design of ICPT systems applied to electric vehicle battery charge," *IEEE Trans. on Industrial Electronics*, vol. 56 , no. 6, pp. 2140 - 2149, 2009.
- [49] U. K. Madawala, D.J. Thrimawithana, "A bidirectional inductive power interface for electric vehicles in V2G systems," *IEEE Trans. on Industrial Electronics*, vol. 58, no. 10 pp. 4789 - 4796, 2011.

- [50] A. Esser, "Contactless charging and communication for electric vehicles," *IEEE Industry Applications Magazine*, Vol. 1, No. 6, pp. 4 – 11, 1995.
- [51] F. Sato and et al. "Contactless energy transmission to mobile loads by CLPS-test driving of an EV with starter batteries", *IEEE Trans. on Magnetics*, vol. 33, no. 5, pp.4203 – 4205, 1997.
- [52] S. Hasanzadeh, S. Vaez-zadeh, A. H. Isfahani "Optimization of a Contactless Power Transfer System for Electric Vehicles," *IEEE Trans. on Vehicular Technology*, vol. 61, no. 8, pp. 3566-3573, 2012.
- [53] G. A. Covic, J. T. Boys, M. L. G. Kissin, H. G. Lu, "A three-phase inductive power transfer system for roadway-powered vehicles," *IEEE Trans. on Industrial Electronics*, vol. 54, no. 6, pp. 3370 - 3378 , 2007.
- [54] M.L.G. Kissin, J.T. Boys, G.A. Covic, "Interphase mutual inductance in polyphase inductive power transfer systems," *IEEE Trans. on Industrial Electronics*, vol. 56, no. 7, pp. 2393 - 2400, 2009.
- [55] J. J. Huh , S. W. Lee, W. Y. Lee, G. H. Cho, C. T. Rim, "Narrow-width inductive power transfer system for online electrical vehicles," *IEEE Trans. on Power Electronics*, vol. 26, no. 12, pp. 3666 - 3679, 2011.
- [56] E. Abel, S. Third, "Contactless power transfer-An exercise in topology", *IEEE Trans. on Magnetics*, vol. 20, no. 5, pp.1813 – 1815, 1984.
- [57] G. Elliott, G. Covic, and D. Kacprzak, "A new concept: Asymmetrical pick-ups for inductively coupled power transfer monorail systems," *IEEE Trans. on Magnetics*, vol. 42, no. 10, pp. 3389-3391, 2006.
- [58] K. Woo and et al. "Contactless energy transmission system for linear servo motor", *IEEE Trans. on Magnetics*, vol. 41, no. 5, pp.1596 – 1599, 2005.
- [59] M. Jufer, "Electric drive system for automatic guided vehicles using contact-free energy transmission", *13th Power Electronics and Motion Control Conference, 2008*. pp.1 – 6.
- [60] M. Ragheb, "Magnetic confinement fusion" , 11/22/2008
- [61] S. Hasanzadeh, S. Vaez-zadeh, "Design of a Wireless Power Transfer System for High Power Moving Applications," *Progress in Electromagnetics Research M*, vol. 28, pp. 258-271, Jan. 2013.
- [62] G. Elliott, S. Raabe, G. A. Covic, and J. T. Boys, "Multi-phase pickups for large lateral tolerance contactless power-transfer systems," *IEEE Trans. on Industrial Electronics*, , vol. 57, no. 5, pp. 1590–1598, 2010.
- [63] G. Covic, S. Raabe, "Practical design considerations for contactless power transfer quadrature pick-ups," *IEEE Trans. on Industrial Electronics*, vol. 60, no. 1, pp. 400-409, 2013.
- [64] J. de Boeij, E. Lomonova, and J. Duarte, "Contactless planar actuator with manipulator: a motion system without cables and physical contact between the mover and the fixed world," *IEEE Trans. on Industry Applications*, vol. 45, no. 6, pp. 1930–1938, 2009.
- [65] P. Sergeant and A. Van den Bossche, "Inductive coupler for contactless power transmission," *IET Electric Power Applications*, vol. 2, no. 1, pp. 1–7, 2008.
- [66] J. Hirai, T. W. Kim, and A. Kawamura, "Study on intelligent battery charging using inductive transmission of power and information," *IEEE Trans. on Power Electronics*, vol. 15, no. 2, pp. 335–345, 2000
- [67] K. Fotopoulou and B. W. Flynn, "Wireless Power Transfer in Loosely Coupled Links: Coil Misalignment Model," *IEEE Trans. on Magnetics*, vol. 47, no. 2, pp. 416–430, Feb. 2011.
- [68] M. Kissin, G. Covic, and J. Boys, "Steady-state flat pickup loading effects in poly-phase inductive power transfer systems," *IEEE Trans. on Industrial Electronics*, vol. 58, no. 6, pp. 2274-2282, 2011.
- [69] H. Matsumoto and Y. Neba, "Model for three-phase contactless power transfer system," *IEEE Trans. Power Electronics*, vol. 26, no. 9, pp. 2676-2687, 2011.
- [70] H. Matsumoto, Y. Neba, K. Ishizaka, R. Itoh, "Comparison of characteristics on planar contactless power transfer systems," *IEEE Trans. on Power Electronics*, vol. 27, no. 6, pp. 2980-2993, 2012.
- [71] W. Zhong, X. Liu, and R. Hui, "A novel single-layer winding array and receiver coil structure for contactless battery charging systems with free-positioning and localized charging features," *IEEE Trans. on Industrial Electronics*, vol. 58, no. 9, pp. 4136–4144, 2011.
- [72] Y.-ho Kim, "Design and implementation of a rectangular type contactless transformer," *IEEE Trans. on Industrial Electronics*, vol. 58, no. 12, pp. 5380-5384, 2011.
- [73] J. P. C. Smeets, T. T. Overboom, J. W. Jansen, and E. A. Lomonova, "Three-Dimensional Magnetic Field Modeling for Coupling Calculation Between Air-Cored Rectangular Coils," *IEEE Trans. on Magnetics*, vol. 47, no. 10, pp. 2935-2938, 2011.
- [74] M. Budhia, G. A. Covic, and J. T. Boys, "Design and optimization of circular magnetic structures for lumped inductive power transfer systems," *IEEE Trans. on Power Electronics*, vol. 26, no. 11, pp. 3096-3108, 2011.
- [75] M. Budhia, G. Covic, J. Boys, and C. Huang, "Development of a single-sided flux magnetic coupler for electric vehicle IPT charging systems," accepted to *IEEE Trans. on Industrial Electronics*, vol. 60, no. 1, pp. 318-328, 2013.
- [76] X. Zhang, S. Ho, and W. Fu, "Quantitative analysis of a wireless power transfer cell with planar spiral structures," *IEEE Trans. on Magnetics*, vol. 47, no. 10, pp. 3200–3203, 2011.
- [77] M. Kiani, U.-M. Jow, and M. Ghovanloo, "Design and optimization of a 3-coil inductive link for efficient wireless power transmission," *IEEE Trans. on biomedical circuits and systems*, vol. 5, no. 6, pp. 579- 591, 2011.

- [78] Z. N. Low, R. A. Chinga, R. Tseng, and J. Lin, "Design and test of a high-power high-efficiency loosely coupled planar wireless power transfer system," *IEEE Trans. on Industrial Electronics*, vol. 56, no. 5, pp. 1801–1812, 2009.
- [79] S. Valtchev, B. Borges, K. Brandisky, and J. B. Klaassens, "Resonant contactless energy transfer with improved efficiency," *IEEE Trans. on Power Electronics*, vol. 24, no. 3, pp. 685–699, 2009.
- [80] B. Cannon, J. Hoburg, and D. Stancil, "Magnetic resonant coupling as a potential means for wireless power transfer to multiple small receivers," *IEEE Trans. on Power Electronics*, vol. 24, no. 7, pp. 1819–1825, 2009.
- [81] A. P. Sample, D. A. Meyer, and J. R. Smith, "Analysis, experimental results, and range adaptation of magnetically coupled resonators for wireless power transfer," *IEEE Trans. on Industrial Electronics*, vol. 58, no. 2, pp. 544–554, 2011.
- [82] C. J. Chen, T. H. Chu, C. L. Lin, and Z. C. Jou, "A study of loosely coupled coils for wireless power transfer," *IEEE Trans. on Circuits and Systems II: Express Briefs*, vol. 57, no. 7, pp. 536–540, 2010.
- [83] S. Cheon, Y.-hae Kim, S.-youl Kang, M. Lee, J.-moo Lee, and T. Zyung, "Circuit Model Based Analysis of a Wireless Energy Transfer System via Coupled Magnetic Resonances," *IEEE Trans. on Industrial Electronics*, vol. 58, no. 7, pp. 2906–2914, 2011.
- [84] T. Imura and Y. Hori, "Maximizing air gap and efficiency of magnetic resonant coupling for wireless power transfer using equivalent circuit and neumann formula," *IEEE Trans. on Industrial Electronics*, vol. 58, no. 10, pp. 4746–4752, 2011.
- [85] T. P. Duong and J. W. Lee, "Experimental results of high-efficiency resonant coupling wireless power transfer using a variable coupling method," *IEEE Microwave and Wireless Components Letters*, vol. 21, no. 8, pp. 442–444, 2011.
- [86] S. H. Lee and R. D. Lorenz, "Development and validation of model for 95% efficiency, 220 W wireless power transfer over a 30cm air-gap," *IEEE Trans. on Industry Applications*, vol. 47, no. 6, pp. 2495–2504, 2011.
- [87] W. Zhong, C. Lee, and R. Hui, "General analysis on the use of tesla's resonators in domino forms for wireless power transfer," *IEEE Trans. on Industrial Electronics*, vol. 60, no. 1, pp. 261–270, 2013.
- [88] W.-sang Lee, W.-ik Son, K.-sub Oh, and J.-won Yu, "Contactless energy transfer systems using antiparallel resonant loops," *IEEE Trans. on Industrial Electronics*, vol. 60, no. 1, pp. 350–359, 2013.
- [89] L. Chen, S. Liu, Y. Zhou, and T. Cui, "An optimizable circuit structure for high- efficiency wireless power transfer," *IEEE Trans. on Industrial Electronics*, vol. 60, no. 1, pp. 339–349, 2013.
- [90] T. Mizuno, S. Yachi, and A. Kamiya, "Improvement in efficiency of wireless power transfer of magnetic resonant coupling using magnetoplated wire," *IEEE Trans. on Magnetics*, vol. 47, no. 10, pp. 4445–4448, 2011.
- [91] S. Hasanzadeh, S. Vaez-Zadeh, "Enhancement of overall coupling coefficient and efficiency of contactless energy transmission systems," *IEEE sponsored Conf. PEDSTC*, 2011, pp. 638 – 643.
- [92] S. Hasanzadeh, S. Vaez-zadeh, "Efficiency Analysis of Contactless Electrical Power Transmission Systems," *Elsevier Energy Conversion and Management*, vol. 65, pp. 487–496, 2013.
- [93] A. J. Moradewicz and M. P. Kazmierkowski, "Contactless energy transfer system with FPGA-controlled resonant converter," *IEEE Trans. on Industrial Electronics*, vol. 57, no. 9, pp. 3181–3190, 2010.
- [94] C. S. Tang, Y. Sun, Y. G. Su, S. K. Nguang, and A. P. Hu, "Determining multiple steady-state ZCS operating points of a switch-mode contactless power transfer system," *IEEE Trans. on Power Electronics*, vol. 24, no. 2, pp. 416–425, 2009.
- [95] Z. Pantic, S. Bai, and S. M. Lukic, "ZCS-LCC Compensated Resonant Inverter for Inductive-Power-Transfer Application," *IEEE Trans. on Industrial Electronics*, vol. 58, no. 8, pp. 3500–3510, 2011.
- [96] J. U. W. Hsu, A. P. Hu, and A. Swain, "A wireless power pickup based on directional tuning control of magnetic amplifier," *IEEE Trans. on Industrial Electronics*, vol. 56, no. 7, pp. 2771–2781, 2009.
- [97] N. A. Keeling, G. A. Covic, and J. T. Boys, "A unity-power-factor IPT pickup for high-power applications," *IEEE Trans. on Industrial Electronics*, vol. 57, no. 2, pp. 744–751, 2010.
- [98] H. H. Wu, G. A. Covic, J. T. Boys, and D. J. Robertson, "A series-tuned inductive-power-transfer pickup with a controllable AC-voltage output," *IEEE Trans. on Power Electronics*, vol. 26, no. 1, pp. 98–109, 2011.
- [99] J. J. Casanova, Z. N. Low, and J. Lin, "Design and optimization of a class-E amplifier for a loosely coupled planar wireless power system," *IEEE Trans. on Circuits and Systems II: Express Briefs*, vol. 56, no. 11, pp. 830–834, 2009.
- [100] U. K. Madawala and D. J. Thrimawithana, "Current sourced bi-directional inductive power transfer system," *IET Power Electronics*, vol. 4, no. 4, pp. 471–480, 2011.
- [101] U. Madawala, M. Neath, and D. Thrimawithana, "A power-frequency Controller for Bidirectional Inductive Power Transfer Systems," *IEEE Trans. on Industrial Electronics*, vol. 60, no. 1, pp. 310–317, 2013.
- [102] D. Thrimawithana, U. Madawala, and M. Neath, "A synchronization technique for bidirectional IPT systems," *IEEE Trans. on Industrial Electronics*, vol. 60, no. 1, pp. 301–309, 2013.
- [103] H. L. Li, A. P. Hu, and G. Covic, "A direct AC-AC converter for inductive power transfer systems," *IEEE Trans. on Power Electronics*, vol. 27, no. 2, pp. 661–668, 2012.

- [104] P. Bauer, M. Castilla, and F. Pijl, "Control method for wireless inductive energy transfer systems with relatively large air gap," *IEEE Trans. on Industrial Electronics*, vol. 60, no. 1, pp. 382–390, 2013.
- [105] S. Hasanzadeh, S. Vaez-Zadeh, "Performance Analysis of Contactless Electrical Power Transfer for Maglev", *Journal of magnetics*, vol. 17, no. 2, pp. 115-123, June 2012.
- [106] Omer C. Onar, John M. Miller, Steven L. Campbell, Chester Coomer, Cliff. P. White, and Larry E. Seiber, "A Novel Wireless Power Transfer for In-Motion EV/PHEV Charging," in *Proc. 28th Applied Power Electronics Conference and Exposition (APEC)*, 17-21 Mar., Long Beach, CA, USA, 2013, pp. 3073-3080.
- [107] Puqi Ning, John M. Miller, Omer C. Onar, and Clifford P. White, "A Compact Wireless Charging System for Electric Vehicles," in *Proc. IEEE Energy Conversion Congress and Expo, ECCE*, 15-19 Sept., Denver, CO, USA, 2013, pp. 3629-3634.
- [108] Z. Panic, S. M. Lucik, "Framework and Topology for Active Tuning of Parallel Compensated Receivers in Power Transfer Systems," *IEEE Trans. Power Electronics*, vol. 27, pp. 4503-4513, 2012.



Head of Power Division from 1998 to 2000 and currently is the Director of Advanced Motion Systems Research Laboratory which he founded in 1998 and the Director of Electrical Engineering Laboratory since 1998. He has been active in IEEE sponsored conferences as a member of technical and steering committees, session chair, etc. His research interests include advanced rotary and linear electric machines and drives, motion control, magnetic levitation, electric and hybrid vehicles and power system stability and control. He has published over 150 technical papers in these areas. Prof. Vaez-Zadeh is a member of IEEE PES Motor Sub-Committee and Power System Stability Control Sub-Committee. He has received a number of awards domestically including a best paper award from Iran Ministry of Science, Research and Technology in 2001 and a best research award from the University of Tehran in 2004. He is an Editor of IEEE Transactions on Energy Conversion and an Editor of Journal of Faculty of Engineering, the oldest technical research journal in the Middle East. He is also a founding member of the editorial board of Iranian Journal of Electrical and Computer Engineering. He has been active in IEEE sponsored conferences as a member of technical and steering committees, session chair, etc.

Saeed Hasanzadeh received the B.S. degree from Shahrood University of Technology, Shahrood, Iran, in 2003, and the M.Sc. and Ph.D. degrees from University of Tehran, Tehran, Iran, in 2006 and 2012, respectively, all in electrical engineering. He joined the faculty of Electrical and Computer Engineering, Qom University of Technology as an Assistant Professor in 2013. His research interests include Power Electronics, Inductive Power Transfer Systems, Electrical Machines and Drives, Electric Vehicles, Magnetic Levitation Systems.



Sadegh Vaez-Zadeh received the B.Sc. degree from Iran University of Science and Technology, Tehran, Iran, in 1985 and the M.Sc. and Ph. D. degrees from Queen's University, Kingston, ON, Canada, in 1993 and 1997, respectively, all in electrical engineering. He has been with several research and educational institutions in different positions before joining the University of Tehran in 1997 as an Assistant Professor and becoming an Associate Professor in 2001 and a Full Professor in 2005. He served the university as the

Head of Power Division from 1998 to 2000 and currently is the Director of Advanced Motion Systems Research Laboratory which he founded in 1998 and the Director of Electrical Engineering Laboratory since 1998. He has been active in IEEE sponsored conferences as a member of technical and steering committees, session chair, etc. His research interests include advanced rotary and linear electric machines and drives, motion control, magnetic levitation, electric and hybrid vehicles and power system stability and control. He has published over 150 technical papers in these areas. Prof. Vaez-Zadeh is a member of IEEE PES Motor Sub-Committee and Power System Stability Control Sub-Committee. He has received a number of awards domestically including a best paper award from Iran Ministry of Science, Research and Technology in 2001 and a best research award from the University of Tehran in 2004. He is an Editor of IEEE Transactions on Energy Conversion and an Editor of Journal of Faculty of Engineering, the oldest technical research journal in the Middle East. He is also a founding member of the editorial board of Iranian Journal of Electrical and Computer Engineering. He has been active in IEEE sponsored conferences as a member of technical and steering committees, session chair, etc.

AUTHORS' ADDRESSES

Asst. Prof. Saeed Hasanzadeh, Ph.D.
Qom University of Technology,
Khodakaram Blvd, 1519-37195, Old Qom-Tehran, road,
Qom, Iran
email: shasanzadeh@ut.ac.ir

Prof. Sadegh Vaez-Zadeh, Ph.D.
School of Electrical and Computer Engineering,
University College of Engineering,
University of Tehran,
North Kargar st., 14395-515, Tehran, Iran
email: vaezs@ut.ac.ir

Received: 2013-12-23

Accepted: 2014-10-13