

OCJENA PRECIZNOG DIELEKTIČNOG MODELA I IZABRANIH PATENTA O OTKRIVANJU RAKA DOJKE POMOĆU MIKROVALOVA

ASSESSMENT OF ACCURATE DIELECTRIC MODEL AND SELECTED PATENTS ON MICROWAVE BREAST CANCER DETECTION

Emine Avşar Aydın, Mustafa Berkan Biçer, Ali Akdağlı

Izvorni znanstveni članak

Sažetak: Ovaj rad govori o naprecima u otkrivanju i snimanju raka dojke pomoću mikrovalova u posljednjem desetljeću. Dan je uvod o raku dojke i metodama otkrivanja te detaljne informacije o snimanju pomoću mikrovalova i izabranim patentima. Raspravljene su prednosti i nedostaci prezentiranih patenata kao i trenutno stanje u detektiranju i snimanju raka dojke. Snimanje mikrovalovima kako bi se otkrio rak dojke metoda je od koje se mnogo očekuje, pošto se smatra kako postoje znatni ili primjetni kontrasti između malignih, benignih i normalnih tkiva kroz široki raspon frekvencija. Također, postoje mnogi dielektrični modeli, posebno se dvostruki Debye model koristio u definiranju dielektričnog odziva raznih bioloških tkiva. S druge strane, dvostruki Debye model nije precizan prilikom korištenja za ljudska tkiva, jer postoje ograničenja u saznanjima oko strukture, dinamike i makroskopskog ponašanja tkiva dojke. Neophodno je, ovisno o frekvenciji, izabrati ispravan dielektrični model u sustavima za detekciju.

Ključne riječi: benigna tkiva, debye model, dielektrični model, maligna tkiva, snimanje mikrovalovima,

Original scientific paper

Abstract: Advances in microwave breast cancer detection and imaging during last decade are reported in this review paper. An introduction to breast cancer and detection methods and detailed information about microwave imaging and selected patents are presented. The advantages and disadvantages of the presented patents and also state of breast cancer detection and imaging are discussed. Microwave imaging for breast tumor detection is considered to be promising, as it is believed that there is a significant or detectable contrast in malignant, benign and normal tissues over a broad frequency range. Also, there have been many dielectric models, especially the double Debye model has been used to define the dielectric response of different biological tissues. On the other hand, double Debye model is not accurate for human breast tissue because there are knowledge limitations about the structure, dynamics, and macroscopic behavior of breast tissue. It is vital that, according to frequency, accurate dielectric model should be chosen in detection systems.

Keywords: microwave imaging, malignant tissue, benign tissue, debye model, dielectric model

1. INTRODUCTION

Breast cancer occurs in the breast. The breast tissue has a large area. It covers the area between the collarbone and armpit including the breastbone.

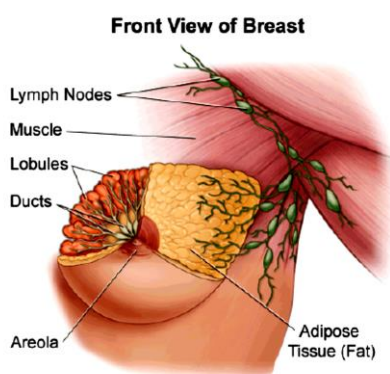

Figure 1. Internal structure of the breast[1]

The breast lies on the chest muscles. Each breast consists of glands, ducts and fatty tissue. A group of glands is said to be lobules. These groups can produce milk. Milk flows from the lobules through a network of ducts to the nipple. Spaces between the lobules and ducts are filled fatty tissue shown in Figure 1.

When there are mutations, or abnormal changes, in the genes responsible for regulating the growth of cells, cancer occurs. The genes are “control room”. It is known that during cell growth, all the cells in our body is refreshed and healthy cells take place instead of dying cells. But, cancer cells can turn on certain cells and kill others in a cell. Because of this, this case is an uncontrolled growth of breast cancer. Breast cancer usually occurs either in the cells of the lobules, or the ducts. However, every woman has her menstrual cycle due to the nature. In these cycles, breasts of women have different structures. At the same time, the structure of the breast tissue shows differences with age. For instance,

breast tissue of young women has glands and milk ducts, but breast tissue of old women has mostly fatty tissue.

According to the latest American Cancer Society Report, the most deaths of women in the US is due to breast cancer [2]. Although the breast cancer is the second most common cancer after lung cancer in the world, early diagnosis plays an important role to decrease the death rate. Many methods have been developed to detect the cancerous cells. For different frequencies of the microwaves, the malignant cells shows different electrical characteristics respect to the normal cells [3]. Due to this property of the breast tissue, the microwaves can be used for detecting of breast cancer.

Some important conditions of breast screening methods should be taken into consideration. These conditions are: comfort of the patients, producing high resolution images, cost and accuracy to detect malignant tumors [3].

The latest breast cancer detection technique is microwave imaging. There are many techniques to detect breast cancer. But these techniques, X-ray mammography, are inadequate for detection of the small group of malignant cells, are harmful because of their X-ray radiation [3, 4, 5, 6].

Microwave imaging makes a promise to be a safe and efficient breast cancer screening method. Previous studies show that microwave imaging is a cheaper and much safer technique than other modalities for breast cancer detection. Since the technique uses non-ionizing radiation, it is considered to be less harmful to patients [7].

Microwave breast imaging techniques consist of tomography and radar-based imaging. Communication of through breast is saved by microwave tomography. At the same time, an electrical property map of the region of interest is created. On the other hand, radar-based techniques focus on reflections from the breast in order to determine the location of meaning scatterers [3, 8].

In this paper, issues which are what is microwave imaging technique, and why are going on studies of breast cancer detection by using microwaves are focused on. In addition, there are many dielectric models. It is important to use accurately these models.

2. MICROWAVE IMAGING TECHNIQUE

Microwave imaging technique most widely has been studied for the detection of breast cancer. The main principle is based on the electrical properties; permittivity and conductivity, of malignant breast tumors tissue differ from those of the normal surrounding breast tissue. The breast is illuminated by the transmitting antennas and the signals scattered from the breast are collected by the receiving antennas. These signals have information about the tumor size, shape, location and electrical properties. Cancerous tissues have different dielectric permittivities and conductivities than healthy breast tissues. So, when an incident wave is sent, cancerous tissue scatters differently indicating their presence [9, 10].

3. SELECTED PATENTS ON MICROWAVE BREAST CANCER DETECTION

Several configurations of microwave breast cancer detection have been patented in recent years. Considering the deaths due to breast cancer, it has become a serious problem for all women. The current screening and imaging techniques such as X-ray mammography, ultrasound, and MRI are the key survival for all women. The accuracy of these techniques is only 73% in detecting breast cancer. In addition, the sensitivity and specificity of these techniques have still limitations. Because of this, researchers set out to find alternative techniques for the early detection of breast cancer. The present-day detection methods have still weaknesses. These weaknesses: 1) Each radiologist can read mammograms differently; 2) Specificity of mammography is low; 3) The result of the biopsy of the every lesion which was found by mammography is not malignant or the ratio of this only 20 to 35%; 4) X-ray radiations are known to cause damage to DNA of cells. Therefore, there is a need in the art of medical imaging for a complementary breast imaging tool. Microwave imaging for breast tumor detection is considered to be promising, as it is believed that there is a significant or detectable contrast in malignant, benign and normal tissues over a broad frequency range [9, 10, 11].

The patent named as "*Method for Detection of Tumors of the Breast*" introduces a new method for detection of tumors of the female breast [12]. This method comprises (i) coating the skin of that portion of the body which is to be evaluated for tumors with a heat sensitive color responsive chemical such as cholesterol (ii) heating that portion of the body so coated with penetrating radiation such as diathermy in either the microwave or radio wave frequency and (iii) scanning the color coated skin over that portion of the body so treated as to identify by color change that "hot spots" which indicate the location of possible tumors or lesions.

One of the objects of the present invention is to describe a new method of modified thermography which lacks undesirable side effects [12]. In addition, this invention is a very accurate diagnostic indicator of tumor sites. The other is to show a new color change technique for location of the potential or actual sites of breast tumors in females.

This method is based on different flow speed of blood at tumor tissue and normal tissue [12]. It is stated that the flow speed of the blood at normal tissue is 20 times faster than the tumor tissue. Hence, if the tissues are heated with a diathermy device, normal tissue dissipates its heat through the vascular system more rapidly than the tumor tissue and its heat stays constant during this process while tumor tissue's heat is increased.

The patent entitled as "*Microwave Detection System*" is employed for the detection of cancerous tumors and is particularly effective in the early detection of such tumors [13]. The system comprises a single unit a passive radiometer with an active microwave transmitter. In addition, this system is adapted for sensing subsurface temperatures. By using a solid state transmitter, heating of the subsurface tissue is localized. This localized heating enhances the tumor from a temperature differential standpoint due to vascular insufficiency associated with the thermal characteristics of tumors. This technique makes possible the early detection of cancer tumors. The advantage of this technique is that the level of radiation is

very small and well within safety standards since the applicator is uncoupled from the human body. The patent entitled as “*Microwave Endoscope Detection and Treatment System*” is adapted for use both as an applicator applied externally to the body and furthermore may be used endoscopically [14]. The endoscopic version may be used for the effective treatment and detection of some cancers.

In the patent named as “*Procedure and Apparatus for Noncontacting Measurement of Subcutaneous Temperature Distributions*” [15], a method and apparatus for noncontacting measurement and imaging of subcutaneous temperature distributions for the early detection of breast cancer are described. The system utilizing the method of the present is showed in Fig. (2).

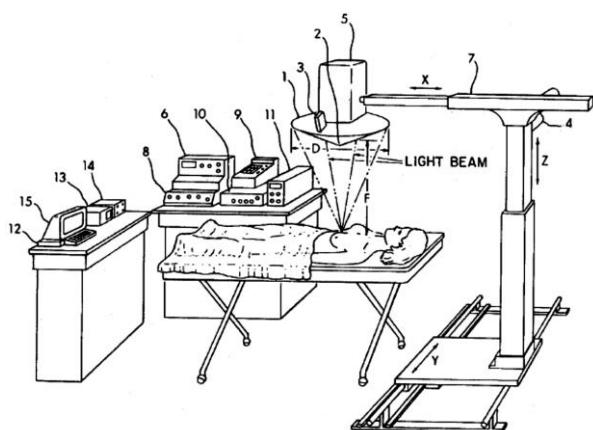

Figure 2. Schema of the system utilizing the method of the present invention[15]

With an elliptical reflector **1** into the receiving horn **2** of the receiving system **5** which is connected with the horn through a bent waveguide or coaxial line, the thermal radiation emitted is brought to a focus in the microwave frequency range of 8 to 36 GHz by a subcutaneous mamma carcinoma [15].

Two focusing light sources **3** are used at the subcutaneous object to indicate the temperature depth measurement with light spacing on the skin [15]. This make it possible to adjust the reflector height over the subcutaneous object focus. The reflected image is used for automatic adjustment of the scanner height. An infrared or photo – detectors is placed on the receiving horn and the height adjusting motor **4**. With automatic movement of the arm **7** which is supporting the reflector **1** and the radiometer **5**, a fast scanning in X-Y direction is performed. Scanning speed, line length and spacing are stored at the controller **8**. The temperature output of the instrument **6** is connected to a strip chart or XY recorder.

It was the purpose of this invention to present a method for contactless subcutaneous temperature measurement giving a higher temperature sensitivity to gether with good spatial resolution which allows detection of deeper lying temperature changes of a small order [15]. This measurement is necessary for reliable early detection of tumors and arthritis. The method also permits shorter imaging times so as to reduce or even completely eliminate the influence of slight temperature changes and body movements during the measurement.

The patent named as “*Medical Diagnostic Microwave Scanning Apparatus*” introduces microwave apparatus for diagnosis of cancer of the breast [16]. This apparatus comprises of the main three parts: a microwave transmitter, a microwave antenna and a microwave receiver. While the microwave transmitter and the microwave antenna are used for directing a microwave signal to the breast under examination, the microwave receiver having amplitude and phase shift detectors is used for receiving of reflected microwave signals. To process the amplitude and phase information, a processor is connected to the receiver. Therefore, the amplitude and phase information can be detected and located cancer in the breast. In order to eliminate any air gap in the transmission path, a matching plate having a dielectric constant substantially the same as normal breast tissue is located between and in engagement with the breast and antenna. It is possible with a display unit to create a microwave image of cancer growth. A microwave scanner for diagnosing cancer of the breast which has a signal processing system is showed in Fig. (3).

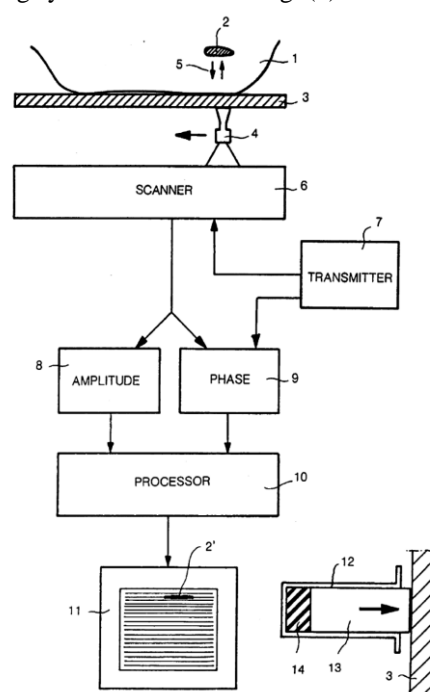

Figure 3. Schema of a Microwave Scanner for Diagnostic Cancer of the Breast which has a Signal Processing System[16]

In the patent named as “*Temperature Measuring Microwave Radiometer Apparatus*” [17], fourth improvement is mentioned in temperature-measuring radiometric equipment. In the first improvement, a microwave radiometer is used to measure the temperature of a specimen. By employing microwave noise power derived from a reference noise source in an amount that corresponds to a temperature higher than that of the specimen, radiometer sensitivity is increased. In the second improvement, a microwave radiometer is used to measure the temperature of patient’s body tissue. Emissivity error is reduced by employing open-loop means comprising a microwave circulator for applying microwave noise power generated by at least one resistor thermostatically heated to a temperature in the

neighborhood of the temperature of a patient's body tissue back to the body tissue.

In the third improvement, system is suitable for use with a standard external applicator as well as for use in an applicator insertable into a natural opening of a patient's body. In addition, cancerous lesions are detected and located. In order to measure the temperature difference between two points of a patient's body tissue or other type of specimen, a microwave radiometer employs two displaced microwave antennas. By combining radiometric equipment with mammographic equipment, fourth improvement has a superior capability for detecting and locating a breast cancer lesion.

The patent named as "Non-Invasive System for Breast Cancer Detection" introduces a system for detecting an incipient tumor in living tissue such as that of a human breast in accordance with difference in relative dielectric characteristics. [18]. Non-ionizing electromagnetic input wave of preselected frequency is produced by a generator. This frequency is higher than three gigahertz. The living tissue is illuminated by input wave. The illumination location is moved over a portion of the living tissue in a predetermined scanning pattern. There are scattered return signals and differences in relative dielectric characteristics. This is indicative of the presence of a tumor in the scanned living tissue. Schema of Non-Invasive System for Breast Cancer Detection is showed in Fig. (4). In the patent named as "Microwave Antenna for Cancer Detection System" [19], in order to irradiate the living tissue and to collect backscatter or other scatter returns, a composite Maltese Cross or bow-tie antenna construction employed is used.

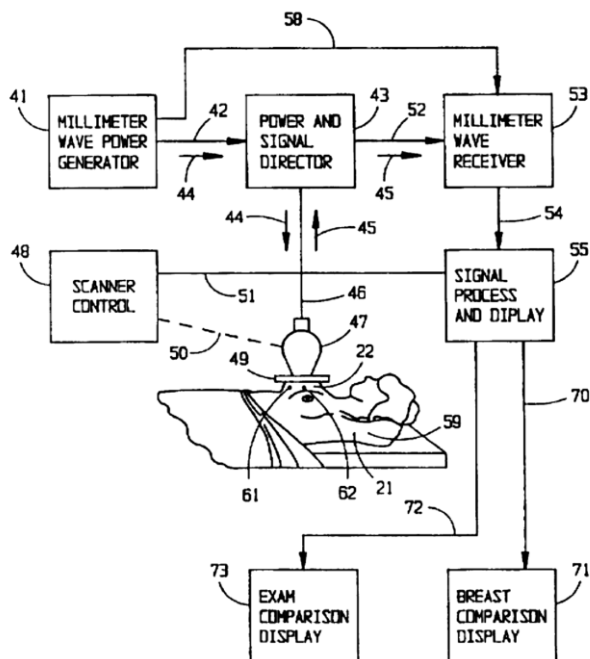

Figure 4. Schema of Non-Invasive System for Breast Cancer Detection[18]

There are eight important features of this invention [18]:

- 1) The selection of a band of operating frequencies. (Optimum operation is at frequencies in the range of three to ninety gigahertz.)

- 2) A wide aperture scanning system is used.
- 3) Techniques that aid in separating the desired scattered returns from a tumor from those originating either directly from the impinging wave form or from spurious reflections from scatterers of no interest.
- 4) In order to develop a synthetic time domain response, a stepped frequency technique is used.
- 5) Confocal techniques are used.
- 6) The combined use of the confocal method with the stepped frequency synthetic time domain method, especially for detecting anomalies at depth.
- 7) It provides convenience to conduct screening.
- 8) It can provide non-hazardous screening functions.

The patent named as "Microwave Detection Tumors, Particularly Breast Tumors" introduces a probe having a working end arranged to contact tissue [20]. There is at least one rectangular waveguide each waveguide having an aperture at the working end of the probe. The waveguides are used to create antennas tuned to receive microwave radiation emitted by the tissue opposite the working end of the probe. In order to detect the temperature of tissue opposite that waveguide, each waveguide is coupled electrically and mechanically to a dedicated radiometer in the probe. Conductive casings are used to insulate thermal distribution of the radiometers. A fragmentary perspective view of microwave detection apparatus is showed in Fig. (5).

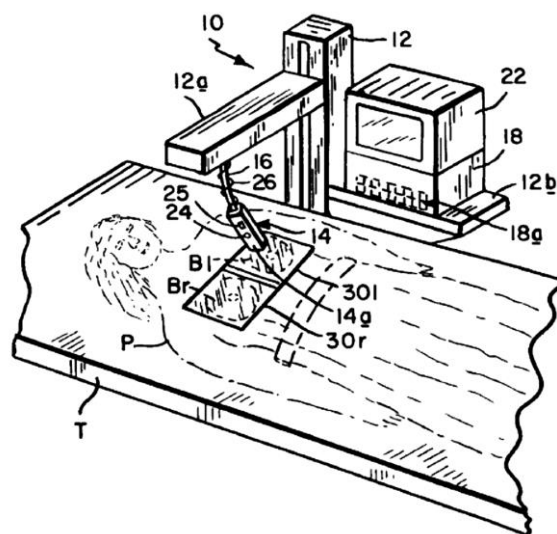

Figure 5. A Fragmentary Perspective View of Microwave Detection Apparatus[20]

An obvious advantage of this invention is that an apparatus makes temperature comparisons at corresponding locations on a patient's two breasts [20]. In addition, it produces an apparatus which can screen for breast tumors in a minimum amount of time. Thus, the breast can be examined in a shorter time than a standard mammography examination with this apparatus.

In another patent "Electrical Impedance Method and Apparatus for Detecting and Diagnosing Diseases" [21], a method and apparatus for screening, sensing, or diagnosing disease are defined. The aim of this method is to utilize a plurality of electrical impedance data measurements in organized patterns from two

anatomically homologous body regions. After subsets of data are processed and analyzed, the matrices and their derivatives are correlated by their characteristics to normal or disease states. Electrical Impedance Measurement System is showed in Fig. (6).

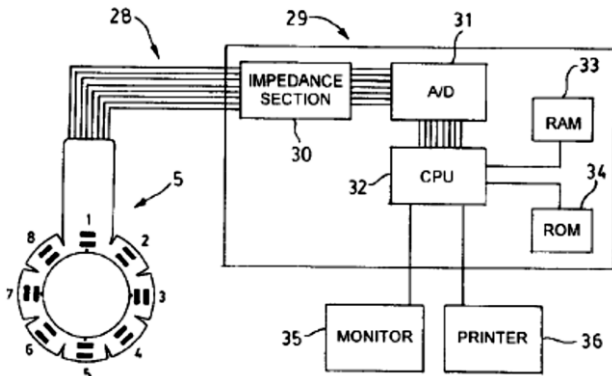

Figure 6. Schema of Electrical Impedance Measurement System[21]

The patent named as “*Microwave Discrimination between Malignant and Benign Breast Tumors*” describes improvements and applications that will characterize the differences between malignant and benign tumors [22]. In order to illuminate a discrete volume within the living tissue of the living organism and to develop scattered power returns from discrete volume, a non-ionizing input wave is applied to a field excitation antenna within a wide band frequency range. A portion of the scattered power returns are collected by a receiving antenna and then applied to signal processor. A separated signal is improved to identify the vascularization associated with one or more malignant tumors.

In another patent “*Multi-Frequency Microwave Induced Thermoacoustic Imaging of Biological Tissues*” [23], the steps of radiating a tissue region with a plurality of microwave radiation pulses are mentioned. Perspective view of a Thermoacoustic Scanning System is showed in Fig. (7). When the microwave pulses which include at plurality of different polarizations swept across a range of microwave frequencies, a plurality of thermoacoustic signals are emitted from the irradiated tissue region. By using the plurality of thermoacoustic signals, one image of the tissue region occurs. The tissue region means breast tissue. The respective images are combined to form an overall image of the breast after a plurality of images from fractional portions of the breast is taken. It is claimed that the frequency range is at least 1 GHz.

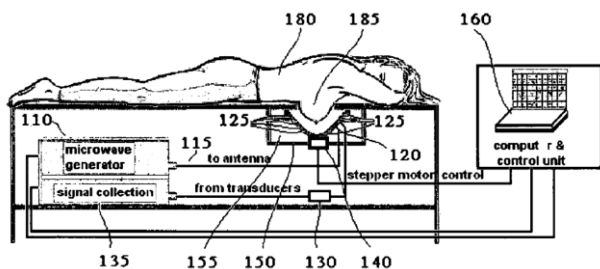

Figure 7. Perspective view of a Thermoacoustic Scanning System[23]

The patent entitled as “*Tissue Sensing Adaptive Radar Imaging for Breast Tumor Detection*” uses microwave backscattering to detect tumours [24]. There have been several approaches about microwave breast imaging such as tomography and radar-based methods. While a map of the electrical properties in the breast using measurements of energy transmitted through the breast is reconstructed in tomography, scattering objects (tumors) using measurements of energy reflected from the breast are detected strongly in radar-based method. In this invention, a radar-based approach is used.

By scanning the focal point through the volume of interest and observing areas of strong reflection, both presence (or absence) of tumor can be detected and localization of tumor is found. Perspective View of the Antenna Locations Used in a Tumor Detecting Scan is showed in Fig. (8).

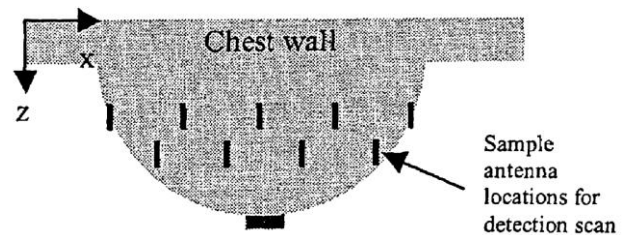

Figure 8. Perspective View of the Antenna Locations Used in a Tumor Detecting Scan[24]

In another patent “*Apparatus and Method for Diagnosing Breast Cancer Including Examination Table*” [25], a microwave breast cancer imaging method including examination table are mentioned. Scanning is both comfortable and reliable through this examination table. Perspective view of an examination table of the invention in use is showed in Fig. (9). In addition, the examination table includes a support system and an orientation system. As shown in Fig. (9), the breast can remain in a fixed position to allow for scanning. The breast with all layers is scanned. In order to develop a microwave response that is indicative of the presence of a lesion, microwave power is scanned upward through the scan plate. The visual imprint of the breast is recorded at the end of scanning. There may be spurious leakage of microwave power. Therefore, microwave-absorbing materials are used to suppress these leakages.

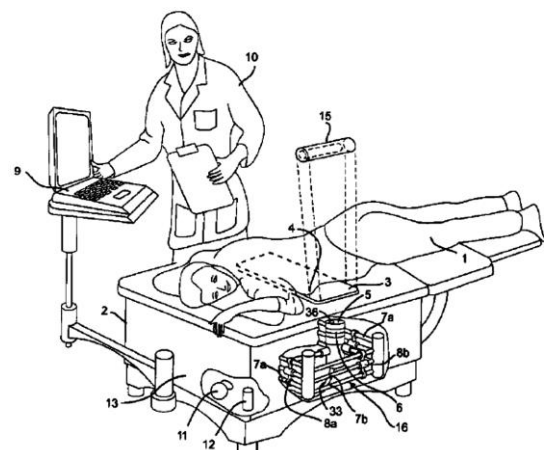

Figure 9. Perspective View of an Examination Table[25]

In the recent patent called “*Microwave Imaging Breast Phantom, Method for Testing Reliability of Breast Cancer Diagnostic Apparatus Using the Phantom, and Breast Cancer Diagnostic Apparatus Including the Phantom*” [26], a breast cancer diagnostic apparatus is tested. This invention includes both a simulated breast tissue phantom and a simulated cancer tissue phantom. A Cross-Sectional View of a Phantom is shown in Fig. (10). The simulated breast tissue and the simulated cancer tissue are created by using a solvent. It is assumed that the simulated cancer tissue phantom is in the simulated breast tissue phantom. Then, the simulated cancer tissue and the simulated breast tissue are separated from each other. In a detailed example, while the simulated breast tissue phantom can have relative permittivity of about 6 to 14 and conductivity of about 0.8 to 1.8 S/m in a frequency of 3 GHz, the simulated cancer tissue phantom can have relative permittivity of about 50 to 60 and conductivity of about 1 to 4 S/m in a frequency of 3 GHz to 1.3 GHz. A breast cancer diagnostic apparatus can include a microwave imaging breast phantom.

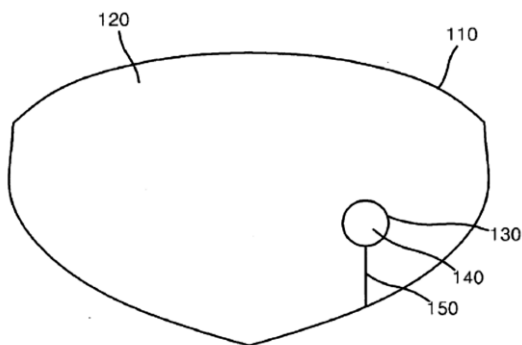

Figure 10. A Cross Sectional View of a Phantom[26]

4. DIELECTRIC MODELS

There have been many dielectric models, especially the double Debye model has been used to define the dielectric response of different biological tissues at terahertz (THz) frequencies. On the other hand, double Debye model is not accurate for human breast tissue. Because there are knowledge limitations about the structure, dynamics, and macroscopic behavior of breast tissue. Because of this, a new dielectric model is proposed in THz regime [27]. By the way, breast cancer detection is better done by this new model. While this new model is used/or suitable in high frequencies, Cole-Cole model has been used in low frequencies. There is an important question that is there a different model in the intermediate frequencies. Therefore, it is vital that according to frequency accurate dielectric model should be chosen in detection systems. In Fig. (11), Cole-Cole model is drawn in high frequencies and it is shown that this model is not suitable in high frequencies. In the same way, new dielectric model is drawn in low frequencies and is not suitable in low frequencies in Fig. (12).

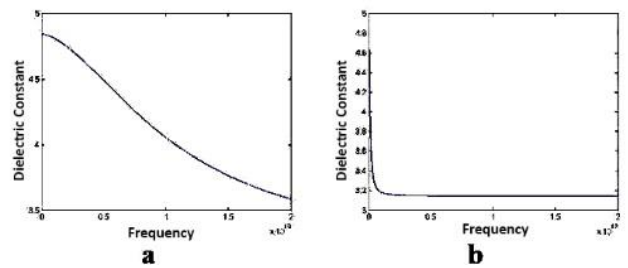

Figure 11. Graphics of Cole-Cole both (a) in the 0-20 GHz frequency range and (b) in the 0-2 THz frequency range

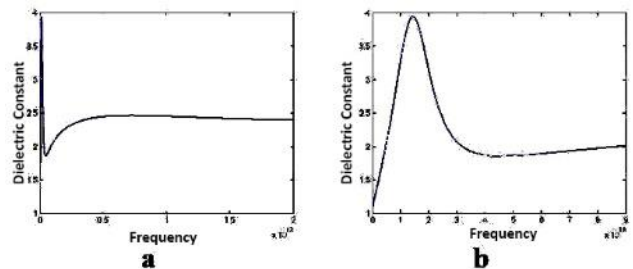

Figure 12. Graphics of New dielectric model both (a) in the 0-20 GHz frequency range and (b) in the 0-2 THz frequency range

5. CONCLUSION

Some noticeable patents on breast cancer imaging and detection that registered in last decade is presented in this study. Breast cancer imaging is an attractive topic and researchers are studying on it to develop new algorithms, methods and prototypes. In future, to image, detect and diagnose the smaller breast tumors with high performance and high resolution, it is expected that more studies for this purpose should be done. Besides, as seen that it is important to select the correct dielectric model according to the frequency.

6. REFERENCES

- [1] <http://www.erg.itu.edu.tr>(Accessed:01.04.2014.), İbrahim Akduman, Hülya Şahintürk, “Mikrodalga Meme Kanseri Tespitinde Yeni Yaklaşımlar: Mikrodalga Meme Kanseri Görüntüleme Sistemi,” Electromagnetic Research Group, Istanbul Technical University,
- [2] <http://www.cancer.org/research/cancerfactsfigures/cancerfactsfiguresforafricanamericans/cancer-facts-figures-for-african-americans>(Accessed:01.04.2014.), Breast Cancer Facts & Figures 2009-2010, American Cancer Society
- [3] M. Xu^a, P. Thulasiraman^{a,*}, and S. Noghianian^b, “Microwave tomography for breast cancer detection on Cell broadband engine processors”, *J. Parallel Distrib. Comput. Elsevier*, Vol. 72, 2012, pp. 1106-1116.
- [4] A. Santorelli and M. Popovic, “SAR distribution in Microwave Breast Screening: Results with TWTLTLA Wideband Antenna”, *Intelligent Sensors*,

- Sensor Networks and Information Processing (ISSNIP), 2011 Seventh International Conference on, Montreal, Canada, 2011, pp. 11-16.*
- [5] A. Lazaro, D. Girbau, and R. Villarino, "Simulated and experimental wavelet-based detection of breast tumor using a UWB radar", *Proceedings of the 40th European Microwave Conference*, Paris, 2010, pp. 373-376.
- [6] Dan Zhang and A. Mase, "Ultrashort-Pulse Radar System for Breast Cancer Detection Experiment: Imaging in frequency band", *Microwave Conference Proceedings (CJMW)*, Hangzhou, 2011, pp. 1-3.
- [7] F. Delbary, M. Brignone, G. Bozza, R. Aramini, and M. Piana, "A visualization method for breast cancer detection by using microwaves", *SIAM on Applied Mathematics*, 70(7), 2010, pp. 2509-2533.
- [8] O. Ogunlade, Y. Chen, and P. Kosmas, "Measurement of the Complex Permittivity of Microbubbles Using a Cavity Perturbation Technique for Contrast Enhanced Ultra-Wideband Breast Cancer Detection", *32nd Annual International Conference of the IEEE EMBS*, Buenos Aires, Argentina, 2010, pp. 6733-6736.
- [9] A. M. Hassan, Student Member, IEEE, and M. El-Shenawee, Senior Member, IEEE, "Review of Electromagnetic Techniques for Breast Cancer Detection", *IEEE Reviews in Biomedical Engineering*, Vol. 4, 2011.
- [10] M. El-Shenawee, "Electromagnetic Imaging for Breast Cancer Research", *BioWireless 2011 IEEE*, pp. 55-58, 2011.
- [11] P. Meaney, M. W. Fanning, T. Zhou, A. Golnabi, S. D. Geimer, and K. D. Paulsen, "Clinical Microwave Breast Imaging-2D Results and the Evolution to 3D", *Electromagnetism in Advanced Applications ICEAA '09 International Conference*, 2009, pp. 881-884.
- [12] R. F. Leveen, "Method for Detection of Tumors of the Breast", United States Patent 4,080,959, March 28, 1978.
- [13] K. L. Carr, "Microwave Detection System", United States Patent 4,346,716, August 31, 1982.
- [14] K. L. Carr, "Microwave Endoscope Detection and Treatment System", United States Patent 4,557,272, December 10, 1985.
- [15] J. Edrich, "Procedure and Apparatus for Noncontacting Measurement of Subcutaneous Temperature Distributions", United States Patent 4,407,292, October 4, 1983.
- [16] R. E. Sepponen, "Medical Diagnostic Microwave Scanning Apparatus", United States Patent 4,641,659, February 10, 1987.
- [17] F. Sterzer and D. D. Mawhinney, "Temperature-Measuring Microwave Radiometer Apparatus", United States Patent 5,688,050, November 18, 1997.
- [18] J. E. Bridges, "Non-Invasive for Breast Cancer Detection", United States Patent 5,704,355, January 6, 1998.
- [19] J. E. Bridges, A. Taflov, S. C. Hagness, and A. Sahakian, "Microwave Antenna for Cancer Detection System", United States Patent 6,061,589, May 9, 2000.
- [20] K. L. Carr, "Microwave Detection of Tumors, Particularly Breast Tumors", United States Patent 5,983,124, November 9, 1999.
- [21] L. W. Organ, "Electrical Impedance Method and Apparatus for Detecting and Diagnosing Diseases", United States Patent 6,122,544, September 19, 2000.
- [22] J. E. Bridges, S. Hagness, A. Taflove, and M. Popovic, "Microwave Discrimination Between Malignant and Benign Breast Tumors", United States Patent 6,421,550 B1, Jul. 16, 2002.
- [23] J. Lia and G. Wang, "Multi-Frequency Microwave-Induced Thermoacoustic Imaging of Biological Tissue", United States Patent 7,266,407 B2, Sep. 4, 2007.
- [24] E. Fear, M. Okoniewski, and M. Stuchly, "Tissue Sensing Adaptive Radar Imaging for Breast Tumor Detection", United States Patent 7,454,242 B2, Nov. 18, 2008.
- [25] R. M. Smith, J. E. Bridges, D. E. Jones, and T. R. Henry, "Apparatus and Method for Diagnosing Breast Cancer Including Examination Table", United States Patent 8,095,204 B2, Jan. 10, 2012.
- [26] J. M. Lee, H. J. Kim, S. H. Son, S. I. Jeon, and H. D. Chol, "Microwave Imaging Breast Phantom, Method for Testing Reliability of Breast Cancer Diagnostic Apparatus Using The Phantom, and Breast Cancer Diagnostic Apparatus Including the Phantom", United States Patent Application Publication US 2014/0002106 A1, Jan. 2, 2014.
- [27] B. C. Q. Truong, H. D. Tuan, A. J. Fitzgerald, V. P. Wallace, and H. T. Nguyen, "A Dielectric Model of Human Breast Tissue in Terahertz Regime", *IEEE Transactions on Biomedical Engineering*, Vol. 62, No. 2, February 2015.

Author contact:

Emine AVŞAR AYDIN, Research Assistant
 Çukurova University, Department of Electrical-Electronic Engineering
 Sarıçam/Adana-TURKEY
 +90-05318436781
 avsare@cu.edu.tr or rasvaenime@gmail.com

Mustafa Berkan BİÇER, Research Assistant
 Mersin University, Department of Electrical-Electronic Engineering
 Mersin-TURKEY
 +90-05321523498
 mberkanbicer@gmail.com

Ali AKDAĞLI, Prof.
 Mersin University, Department of Electrical-Electronic Engineering
 Mersin-TURKEY
 +90-05322322852
 akdagli@mersin.edu.tr