

QINGYANG XU, Ph.D.

E-mail: xuqy1981@163.com

School of Mechanical, Electrical & Information Engineering,
Shandong University
Weihai 264209, China

NING WANG, Ph.D.

E-mail: n.wang.dmu.cn@gmail.com

Marine Engineering College, Dalian Maritime University
Dalian 116026, China

Traffic Management

Review

Submitted: Oct. 6, 2013

Approved Nov. 11, 2014

A SURVEY ON SHIP COLLISION RISK EVALUATION

ABSTRACT

Recently, ship collision avoidance has become essential due to the emergence of special vessels like chemical tankers and VLCCs (very large crude carriers), etc. The information needed for safe navigation is obtained by combining electrical equipment with real-time visual information. However, misjudgements and human errors are the major cause of ship collisions according to research data. The decision support system of Collision avoidance is an advantageous facility to make up for this. Collision risk evaluation is one of the most important problems in collision avoidance decision supporting system. A review is presented of different approaches to evaluate the collision risk in maritime transportation. In such a context, the basic concepts and definitions of collision risk and their evaluation are described. The review focuses on three categories of numerical models of collision risk calculation: methods based on traffic flow theory, ship domain and methods based on dCPA and tCPA.

KEY WORDS

collision risk; collision avoidance; ship domain; fuzzy comprehensive evaluation;

1. INTRODUCTION

In the recent twenty years, with the emergence of new types and large ships, the density of traffic at sea has seen a great change and has become more and more complex. This makes the ship manoeuvring more difficult. At the same time, ARPA (Automatic Radar Plotting Aids), GMDSS (Global Maritime Distress & Safety System), GPS (Global Positioning System) and ECDIS (Electronic Chart Display and Information System), etc. have been applied in navigation. The number of crew is decreasing, and this is a big challenge for the navigator. The latest shipwrecks indicate that human error is still the major factor of accidents [1, 2]. In order to

decrease the number of accidents and increase the safety of navigation, the manoeuvring supporting system is a facilitating device. The collision risk evaluation is the major issue in the supporting system, and it is a basic and significant concept in navigation. There are several kinds of methods for the evaluation [3]. Each method has its advantages and shortcomings. There is no common way at home and abroad, due to the fuzziness and the impossibility to define the collision risk. The selection of collision risk evaluation method is always based on the actual situation. The quantification of collision risk evaluation has experienced several stages:

- (1) The first stage is based on the traffic flow theory. The ship collision rate, encounter rate, collision probability and near miss, etc. are used to assess the collision risk of special water area. These methods are almost based on statistics and traffic investigation.
- (2) The second stage is the presentation of ship domain and arena according to human praxiology and psychology.
- (3) The third is the cognizance of the effect of dCPA (Distance to Closest Point of Approaching) and tCPA (Time to Closest Point of Approaching), and synthesize dCPA, tCPA and other factors to evaluate the collision risk.

Nowadays, the intelligent technologies are used to evaluate the collision risk, including the improvement of traditional methods and new ways of presentation. The aim of the paper is to review the numerical models of collision risk evaluation. Section 2 presents the numerical model based on traffic flow theory, and the ship domain is discussed in Section 3. In Section 4, the numerical model based on dCPA and tCPA is introduced, as well as the methods based on fuzzy theory. Finally, a conclusion is presented in Section 5.

2. COLLISION RISK CALCULATION BASED ON TRAFFIC FLOW THEORY

The collision risk evaluation based on traffic flow theory is a historical one. Although it is not often used now, it is important for the development of the collision risk evaluation. The collision accident of unit time in a certain area is the original way to illustrate the risk of traffic at sea. The collision rate is an improved one, which has different definitions. One is using the ship number of those involved in the collision accident to compare with the number of ship operations in the unit time of a certain area. Cookcroft [4] adopted it to calculate the collision rate of ship with different tonnage in 1956~1980. Another is using the ship number of those involved in the collision accident to compare with the voyages number in the unit time of certain area. For example, the number rose from 0.000097 to 0.000166 during 1969~1978 in American water area. The collision times and rate are based on the investigation data which cannot reflect the potential risk. In order to reflect the potential risk, researchers proposed the encounter rate. Encounter is relative to the actual traffic situation, and collision is the bad result of encounter. Goodwin [5] defined the encounter rate by the danger-encountered times during the given time in a certain area. Fujii took ships as free motional molecules to research encounter. Actual collision rate and encounter rate are not sufficient for the research. The collision probability is defined by Fujii and Yamanouchi [6] as the actual collision times and geometric collision times in certain area of unit time:

$$P_g = \frac{N_c}{N_g} \tag{1}$$

where P_g is collision probability based on geometric collision times, N_c and N_g are the actual collision times and geometric collision times of certain area and time.

Barratt [7] proposed the near miss, which is close to actual collision times and more frequent than actual collision. He used the time clearance to assess the number of near misses. It is the time difference of arriving to the course cross point for two ships. If it is equal to 0, the two ships have a collision. Brok and Vet [8] thought that the major collision accidents are caused by human error according to factual proof. But we cannot express the behaviour of humans in mathematic models. They used the actual collision times and collision avoidance operation to assess collision probability. Collision is caused by collision avoidance failure.

$$P_e = \sum_K m_{T,K} \cdot \pi_{T,K} \tag{2}$$

where P_e is collision probability based on collision avoidance manoeuvres (CAM), $m_{T,K}$ is the CAM times with target T in encounter situation, $\pi_{T,K}$ is the failure probability of CAM. It is a new method for security as-

essment, because the times and failure probability of collision avoidance operation can reflect human behaviour to a certain extent, and contains the factor of encounter and actual collision times. However, it is difficult to obtain the collision avoidance data due to the equipment restriction of that time. Also, there are many other researchers who proposed numerical models to calculate the collision risk. These methods are almost based on statistical data. They are not suitable for dynamic calculation.

3. SHIP DOMAINS-BASED COLLISION RISK EVALUATION

Compared with collision risk evaluation based on traffic flow theory, the ship domain is a better way to assess the ship collision risk.

3.1 Elliptical ship domains

The concept of ship domain was proposed firstly by Fujii. The definition of Fujii's ship domain is [9] "Most of the navigators of the following ships avoid entering the surrounding domain of the fore-going ship". We can see that it is the navigators' feeling about risk. The size of ship domain is defined according to the traffic investigation in Japan. It is an ellipse in the geometrical centre of which is the position of the ship centre and the major semi-axis is along the fore and aft of the ship, and the minor semi-axis is along the bear abeam the ship. The ship domain size of a large ship is that the major semi-axis is 7 times of ship's length L , and the minor semi-axis is 3 times. In overtaking situation, the major semi-axis is 8 times of ship's length L , and the minor semi-axis is 3.2. In harbour and narrow channel, it decreases to 6 and 1.6 times of ship length L , shown in Figure 1. In head-on situation, the Fujii's domain is shown in Figure 2. A half ellipse combination

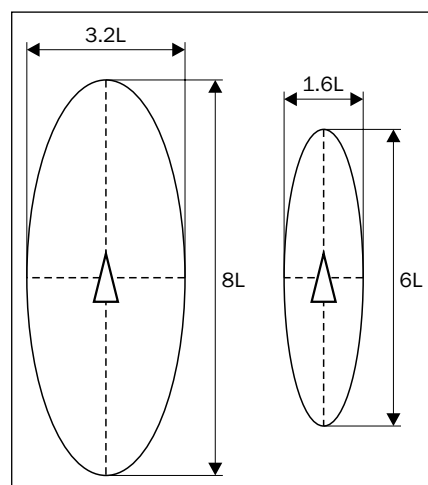

Figure 1 - Fujii's domain at open sea and narrow channel

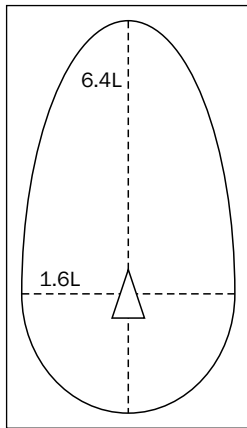

Figure 2 - Fujii's domain in head-on situation

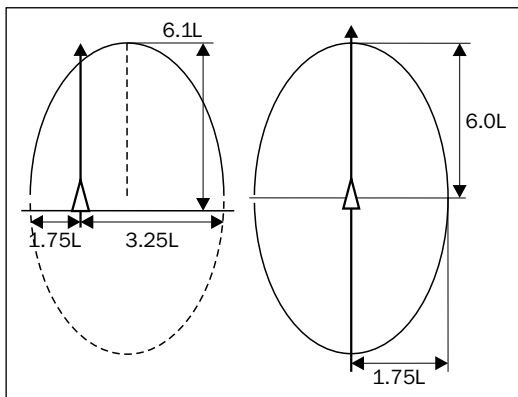

Figure 3 - Ship domain in head-on and overtaking situation

with a half circle is used to construct the ship domain. Astern side is smaller than starboard and port side, which means that there is less danger astern.

Coldwell [10] established the ship domain in head-on and overtaking situations in restricted waters and confirmed the Fujii's ship domain in overtaking situations. The ship domain defined by Coldwell is "The surrounding effective waters which the typical navigator actually keeps clear, considering the existence of other ships". The ship is shifted left by half of the ellipse in the domain, and the starboard is larger than the port side in head-on situations, which is shown in Figure 3. This indicated that the navigator's actions influenced by COLREGS, and confirmed the Goodwin's ship domain with different sectors, too.

3.2 Circular ship domains

Fujii introduced their domain to England in 1971. Then, Goodwin confirmed the existence of ship domain, and established a model of ship domain according to traffic investigation of the south of the North Sea at open sea. It was derived from statistic methods from a large number of records and simulator data. The definition of domain made by Goodwin [11] is "the surrounding effective waters that the navigator of

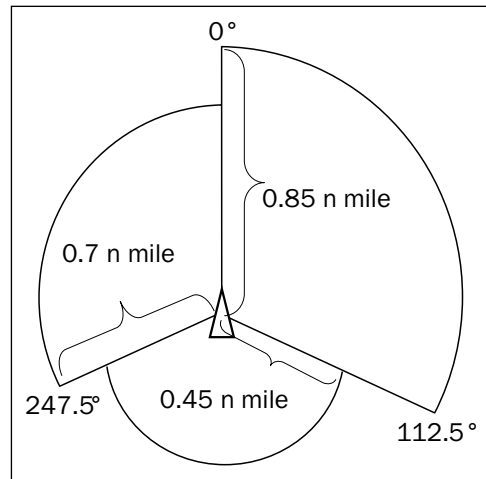

Figure 4 - Ship domain at open sea

a ship wants to keep clear of other ships or fixed objects". The domain is divided into three sectors:

- Sector 1, starboard sector: $0^\circ < \theta < 112.5^\circ$
- Sector 2, astern sector: $112.5^\circ < \theta < 247.5^\circ$
- Sector 3, port sector: $247.5^\circ < \theta < 360^\circ$

Goodwin's model has shown that the navigator's actions were influenced by the COLREGS. The starboard side is larger than the port side, and astern side is the smallest part as shown in Figure 4. From the definition, we can know Goodwin's ship domain is a subjective concept rather than the Fujii's objective one. The subjective domain is the area that a navigator really 'wants' to be kept safe, while the objective domain is the one that a navigator 'has to' accept. The subjective domain is suitable for application of problems such as collision avoidance and assessment of collision risk, while the objective domain is more useful in traffic simulation and path design, etc. Figure 5 indicates the subjective and objective domain of a local ship.

Goodwin's ship domain is not continual and it is not convenient to realize traffic simulation on a computer. Therefore, Davis and Dove [12] started to smooth the

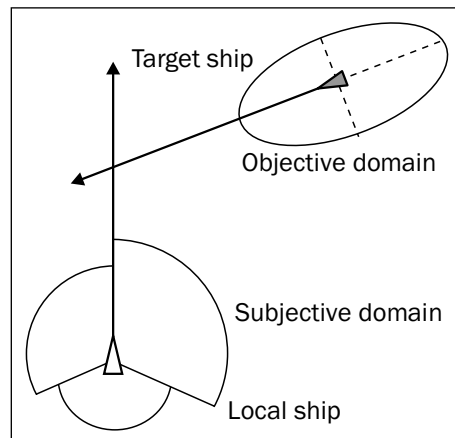

Figure 5 - Subjective and objective ship domain of a local ship

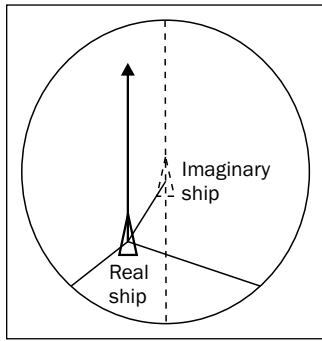

Figure 6 - Davis's ship domain

Goodwin's domain boundary. He made use of a circle whose area is the sum of three sectors to represent the Goodwin's domain. The ship is at lower left quarter to retain the characteristic of the Goodwin's domain. It has the advantage of computer simulation. The domain is shown in Figure 6.

Davis and Dove [13] proposed a concept of Arena, which is used for navigators to determine the time of taking collision avoidance action. If any, we needed to keep our own ship domain un-violated. Arena is a bigger area than the ship domain in which the navigator can adopt action or not when the target ship is in the Arena, which is decided by the target ship violating our domain or not in the future. If it violates our domain in the future, the navigator will adopt action to avoid this [14]. The comparison of Arena and ship domain is shown in Figure 7.

By this time, the theory of ship domain and Arena had been established. In that period and in the following years or so, many scholars modified the ship domain, and carried out practical studies. Since then, ship domain has been widely used to ship collision avoidance, marine traffic simulation, calculation of encounter rates, appraisal of collision risk, and VTS design, etc. With the development of artificial intelli-

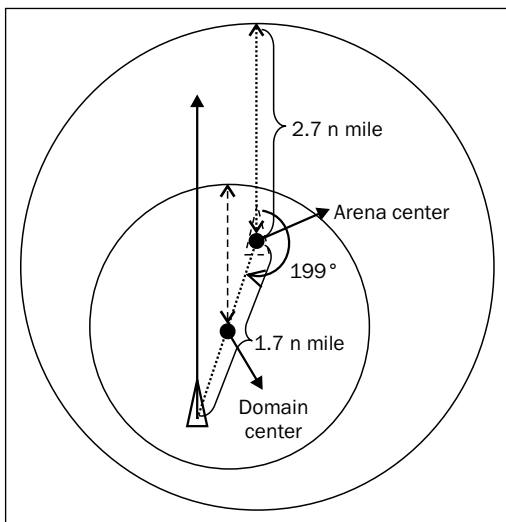

Figure 7 - Comparison of Arena and ship domain

gence, researchers start to apply artificial intelligence in ship domain, such as fuzzy theory, neural network, expert system and others. Fuzzy logic control has emerged as one of the most active and fruitful areas for research in the application of fuzzy set theory, fuzzy logic and fuzzy reasoning [15]. Zhao [16] proposed a definition of fuzzy ship domain which determines a fuzzy ship domain boundary as in Figure 8. The concept of fuzzy boundary for domain (FBD) is that "the relative motion line of a target is outside of the fuzzy boundary, it is safe, no action need be taken; if the relative motion line is just inside the fuzzy boundary, it is not certainly safe, but not certainly dangerous either, action need not be taken; if the relative motion line is inside the fuzzy boundary, it is danger, action must be taken to keep it out of the fuzzy boundary." He notes that "they all refer to a water area around a vessel which is needed to ensure the safety of navigation and to avoid collision". The concept of domain is that the navigator maintains clear of other objects. Zhao's "fuzzy boundary" theory was developed by Pietrzykowski [17]. The concept of ship fuzzy domain boundary is shown in Figure 9, and the navigational safety is expressed by level γ . The safety level can be described by fuzzy boundary. The boundaries of ship domain determined by the average safe distances from target ship observed at various heading angles and different ship sizes. If the distance from ship waterplane centre is small, there

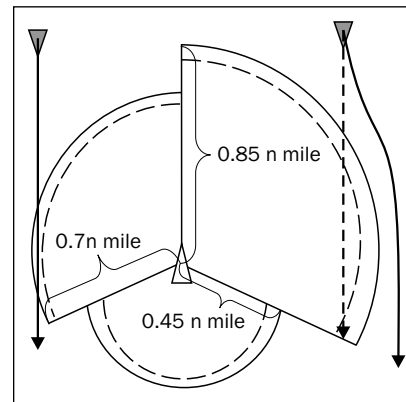

Figure 8 - The fuzzy boundary of ship domain

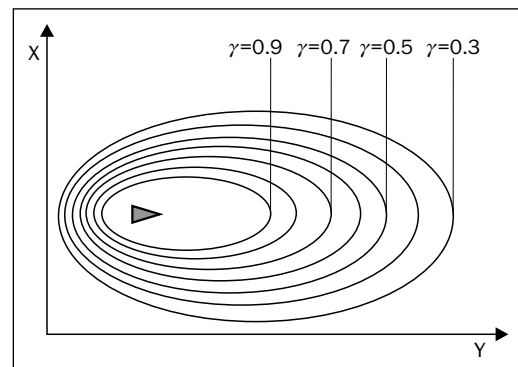

Figure 9 - Ship fuzzy boundaries for various levels of navigation safety γ

will be a danger evaluation value, such as $r = 0.9$; and also we can see that the boundary of ship domain is not a circle which is based on the relative bearing. The ship domain is described dynamically according to the distance from the ship waterplane centre.

3.3 New and complex polygonal ship domains

With the development of ship domain research, some complex domains are proposed. Smierzchalski [18] proposed a hexagon ship domain in restricted areas, whose dimensions can be chosen experimentally. For good visibility, the hexagon dimensions on port side should be larger, which will make the manoeuvre of one's own ship at a sufficient distance from the target in case of course crossing and give-way situation, as in Figure 10. Pietrzykowski [19] proposed a polygonal ship domain which is more complex than others shown in Figure 11. The shapes and sizes of the domain are dependent upon the safety level of navigation, such as $\gamma = 0.9$ and $\gamma = 0.5$. Smierzchalski [20] introduced a new way of collision risk calculation derived from the concept of ship domain, which was flexible to be ap-

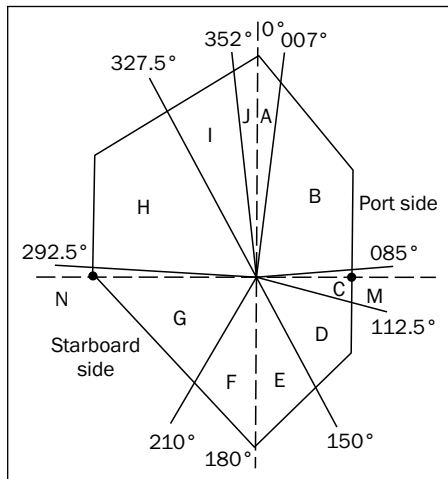

Figure 10 - A hexagon ship domain

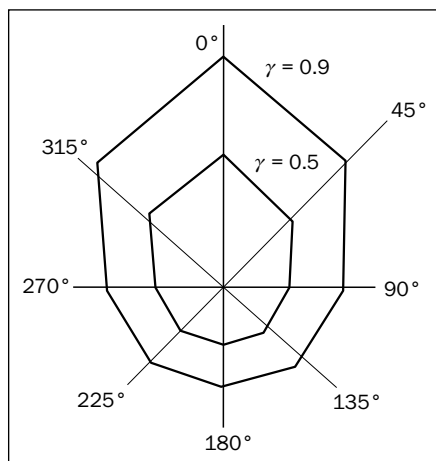

Figure 11 - A polygonal ship domain

plied in combination with any given ship domain. Additionally, he/she used numerical algorithm to determine the value of the ship domain. A generic method for determination of the necessary course alteration was developed.

3.4 Simulation experiment

In navigation, safety is the major issue, so we should try our best to avoid getting into the danger area by adopting collision avoidance action to keep the safety. We make use of typical Arena and ship domain of Davis to realize this. The mathematical model of Arena and Davis's domain [21] can be expressed as:

$$F = X^2 + Y^2 - r^2 \tag{3}$$

$$\begin{cases} X = (x - x_I) \cos \varphi - (y - y_I) \sin \varphi \\ Y = (x - x_I) \sin \varphi - (y - y_I) \cos \varphi \end{cases} \tag{4}$$

$$\begin{cases} x_I = x_R + d \sin(\varphi + 19^\circ) \\ y_I = y_R + d \cos(\varphi + 19^\circ) \end{cases} \tag{5}$$

where F indicates the ship is in Arena and domain or not. If the ship is outside of domain, $F < 0$, r is the radius of Arena or domain, φ is course of ship, d is the distance from one's own ship to the centres of Arena or domain, (x_I, y_I) , (x_R, y_R) are the coordinations of imaged and real ship centre.

We can describe the concrete numerical model of Arena as follows:

$$F = ((x - x_I) \cos \varphi - (y - y_I) \sin \varphi)^2 + ((x - x_I) \sin \varphi - (y - y_I) \cos \varphi)^2 - 2.7^2 \tag{6}$$

$$\begin{cases} x_I = x_R + 1.7 \sin(\varphi + 19^\circ) \\ y_I = y_R + 1.7 \cos(\varphi + 19^\circ) \end{cases} \tag{7}$$

Supposing that, in the water area, the parameters of local ship are: course 121° , expectation course 115° , velocity 15 kn, length 75 m; Target ship: course 126° , expectation course 130° , velocity 11.2 kn, length 110 m. The system calculates the value of F according to the parameters of ships. If $F < 0$, it indicates that the target ship is in Arena, and then the system will evaluate the situation of target ship in the future, and check whether the target is violating our domain or not. If it violates our domain in the future, the system will send a warning signal to the navigator in order to remind him to adopt actions. This is going to keep our ship in the safe area. The following two figures demonstrate the encounter of two ships and process of collision avoidance.

At the beginning of encounter in Figure 12, the target ship is in our Arena and close to local ship domain 1, too. The target will violate the local ship domain in the future according to the calculation. The target ship is the overtaking ship, and the overtaking ship should change their course to avoid the local ship according to CLOREGS. Next, the target ship changes its course,

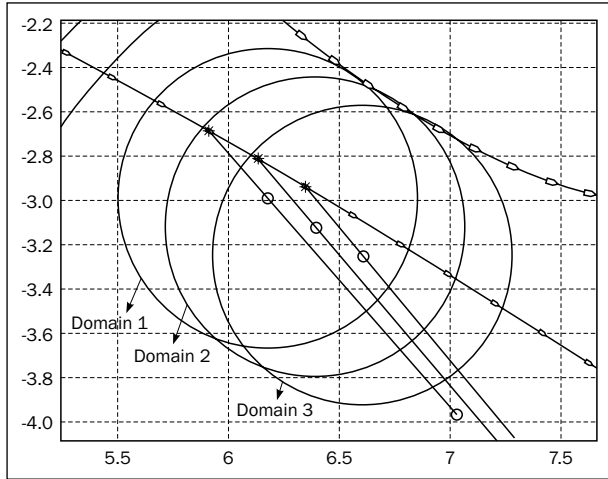

Figure 12 - Encounter situation of two ships

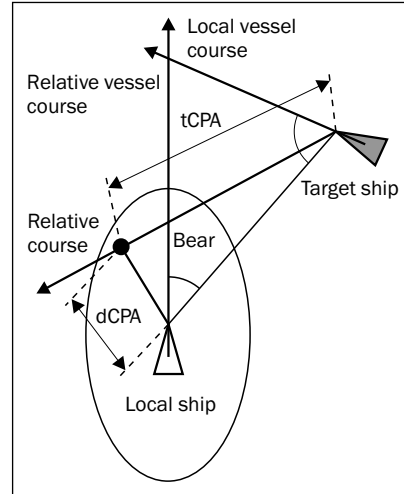

Figure 14 - Chart of ship encounter

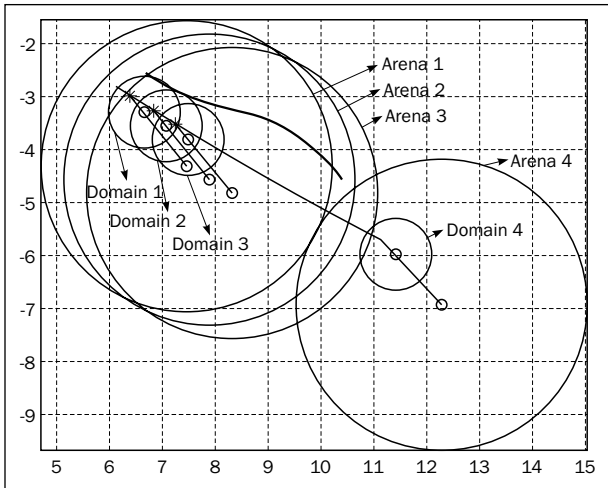

Figure 13 - Collision avoidance process

finally, the target ship is out of our domain 3. Figure 13 is the whole process of collision avoidance, in Arena 1 and domain 1, the target ship will get into local ship domain in the future, then it adopts action; so in Arena 2 and domain 2, the target ship is close to our domain, but not the crossing domain, if the target ship does not adopt action, it will violate the local ship domain; in Arena 3 and domain 3, the target ship is far from domain. The target ship is in our Arena all the time. It is safe, if it does not violate our domain.

4. COLLISION RISK EVALUATION BASED ON dCPA AND tCPA

There are many factors affecting collision risk, including dCPA, tCPA, position of target ship, velocity ratio K , and collision angle θ , etc. But dCPA and tCPA are the most important ones which can be obtained by ARPA [22] as in Figure 14.

Therefore, the number of collision risk evaluation methods were devised for taking dCPA and tCPA into

account in the early stage. Kearon [23] proposed a model using dCPA and tCPA to evaluate the collision risk:

$$\lambda_i = (a \cdot dCPA_i)^2 + (b \cdot tCPA_i)^2 \quad (8)$$

where a, b are the weightings of dCPA and tCPA. The greater λ_i , the greater is the danger of collision. The collision avoidance action must be taken when λ_i reaches a threshold value. An alternative way of collision risk evaluation proposed by Imazu and Koyama [24] is shown as Equation (9),

$$N_c = (a \cdot dCPA + b \cdot V_c) / R \quad (9)$$

where a, b are the weightings, V_c is the component of relative speed of the two ships, R is the distance of two ships. In Equations (8) and (9), the dimension size of dCPA and tCPA, dCPA and V_c are different. Therefore, a and b are used to keep these variables matching. The two methods have the same problem that the variables have different dimension and dCPA and tCPA are in negative correlation, so the evaluation result is not quite good.

4.1 Collision risk evaluation based on Fuzzy Logic

The expert's experience is still essential when a ship is in danger of a collision with others, although a lot of electronic apparatuses have been equipped on-board ships. The researchers combined the expert's experience with fuzzy logic constructing new collision risk assessment system. James [25] proposed a collision avoidance decision model based on fuzzy logic. He discussed this model in head-on situation and with fixed obstacle. He established the fuzzy set of safety and small course changes. Hasegawa and Kouzuki [26] combined the expert system of Koyama with collision avoidance inference, and developed an auto-operation fuzzy expert system (SAFES). The input of inference system is dCPA and tCPA. The fuzzy mapping

of dCPA is “positive small”, “positive middle small”, “positive middle”, “positive middle large” and “positive large”. The fuzzy mapping of tCPA is “negative long”, “negative middle”, “negative short”, “positive short”, “positive middle short”, “positive middle”, “positive middle long” and “positive long”. Yao and Fang [27] thought that there were too many negative values in tCPA. They decreased the negative number of tCPA. Using “very short”, “middle short”, “middle”, “middle long”, “long” to indicate dCPA. He used “small”, “middle small”, “middle”, “middle large”, “large” to indicate dCPA. This would decrease the inference rule number. Sii and Ruxton [28] proposed a safety model using fuzzy logic approach employing the fuzzy IF-THEN rules from human knowledge and reasoning processes without the precise quantitative analyses, such as acquiring the knowledge from the statistical data, the domain human expert analysis, the data according to the experience, then a concept mapping is carried out, and finally the fuzzy model is established. They provided a tool for working directly with the linguistic terms commonly used in carrying out safety assessment. Hwang [29] designed a fuzzy collision-avoidance expert system, which can store facts and rules, and then the inference engine can simulate experts’ decision.

4.2 Collision risk evaluation based on fuzzy comprehensive evaluation method

Fuzzy comprehensive evaluation is a general method in fuzzy theory, using fuzzy mapping principle and considering all of the effecting factors of evaluation object. The comprehensive evaluation result can be used as subjective evaluation, and also objective one. Furthermore, the system security is a progressive process. We can get perfect results through assessing the subordination of factors. Therefore, researchers use the fuzzy comprehensive evaluation instead of using dCPA and tCPA directly.

In literature [30], dCPA and tCPA were used as the input of fuzzy system to calculate the collision risk. The membership function of dCPA is:

$$u(dCPA) = \begin{cases} 1 & , 0 \leq dCPA \leq d_1 \\ \frac{1}{2} - \frac{1}{2} \sin\left[\frac{\pi}{d_2 - d_1} \cdot \frac{dCPA(d_2 + d_1)}{2}\right] & , d_1 < dCPA \leq d_2 \\ 0 & , d_2 < dCPA \end{cases} \quad (10)$$

When dCPA is larger than the threshold d_2 , it is safe according to the actual situation and psychology of navigator. If dCPA is smaller than threshold d_1 , the two ships will have a collision danger. We must take actions. Among the two thresholds d_1 and d_2 , we need to calculate the risk level for collision avoidance. The membership function of tCPA is:

$$u(tCPA) = \begin{cases} 1 & , 0 \leq |tCPA| \leq t_1 \\ \frac{t_2 - tCPA}{t_2 - t_1} & , t_1 < |tCPA| \leq t_2 \\ 0 & , t_2 < tCPA \end{cases} \quad (11)$$

In the formula,

$$\begin{cases} t_1 = \frac{\sqrt{d_1^2 - dCPA^2}}{V_R} & , dCPA \leq d_1 \\ t_1 = 0 & , dCPA > d_1 \end{cases} \quad (12)$$

$$\begin{cases} t_2 = \frac{\sqrt{d_2^2 - dCPA^2}}{V_R} & , dCPA \leq d_2 \\ t_2 = 0 & , dCPA > d_2 \end{cases} \quad (13)$$

where V_R is the relative velocity; d_1 is DLA, minimal distance to adopt collision operation; d_2 is the ship Arena.

The result of collision risk evaluation is as follows:

$$u(dCPA, tCPA) = u(dCPA) \oplus u(tCPA) \quad (14)$$

where

$$a \oplus b = \min\left(\frac{a + b}{2}, 1\right) \quad (15)$$

In Equation (14), we can see that dCPA and tCPA have the same contribution for collision risk evaluation. However, it is not in accordance with the actual navigation experience that dCPA is the first major factor and tCPA is the secondary one in practice. Liu [31] added the distance of two ships R to the comprehensive evaluation except for dCPA and tCPA. In literature, the membership function of R is:

$$u(R) = \begin{cases} 1 & , R \leq r_1 \\ \frac{r_2 - R}{r_2 - r_1} & , r_1 < R \leq r_2 \\ 0 & , r_2 < R \end{cases} \quad (16)$$

where r_1 is DLA, r_2 is $V_R \cdot \left(T + \frac{d_2}{V_R}\right) = d_2 + V_R \cdot T$, T is the time of rotating by 90 degrees.

And then in the final evaluation, the weighting of subordination is adopted instead of equal contribution, which can reflect the different significance of factors.

$$c = a_R u(R) + a_{dCPA} u(dCPA) + a_{tCPA} u(tCPA) \quad (17)$$

where a_R , a_{dCPA} , a_{tCPA} are weighting of R , dCPA and tCPA.

Zheng [32] made use of the parameters (two-ship distance d , target position T , dCPA, tCPA) coming from ARPA and AIS (Automatic Identification System) to construct risk membership function for collision risk evaluation. A different membership function of two-ship distance d is defined in literature as equation (18).

$$u(d) = \begin{cases} 1 & , d < d_i \\ \left[\frac{(d_m - d)}{(d_m - d_i)}\right]^2 & , d_i < d \leq d_m \\ 0 & , d > d_m \end{cases} \quad (18)$$

In the formula,

$$d_i = K_1 \cdot K_2 \cdot K_3 \cdot DLA \quad (19)$$

$$d_m = K_1 \cdot K_2 \cdot K_3 \cdot R \quad (20)$$

Table 1 - The risk membership function of factors

Distance D	$r_D = e^{-\ln 2 \left(\frac{D}{D_0}\right)^2}$, $D \geq 0$, $D_0 > 0$ constant
Relative T	$R_T = \frac{17}{24} \left[\cos(T_0 - T) + \sqrt{\frac{440}{289} + \cos^2(T_0 - T)} \right]$, $0^\circ \leq T \leq 360^\circ$, $0^\circ \leq T_0 \leq 90^\circ$ constant
$dCPA$	$r_{dCPA} = e^{-\ln 2 \left(\frac{dCPA}{dCPA_0}\right)^2}$, $dCPA \geq 0$, $dCPA_0 > 0$ constant
$tCPA$	$r_{tCPA} = e^{-\ln 2 \left(\frac{tCPA}{tCPA_0}\right)^2}$, $tCPA \geq 0$, $tCPA_0 > 0$ constant
Velocity ratio K	$r_K = \frac{1}{1 + (K_0/K)^2}$, $K \geq 0$, $K_0 > 0$ constant
Collision angle θ	$r_\theta = \frac{1}{1 + ((180^\circ - \theta)/\theta_0)^2}$, $0^\circ \leq \theta \leq 180^\circ$, $0^\circ \leq \theta_0 \leq 180^\circ$ constant

where K_1 is the visibility factor, K_2 is the situation of water area, K_3 is the human factor, like the experience, technology and psychology of operator, and K is the radius of Arena.

$$R = 1.7 \cos(T - 19^\circ) + \sqrt{4.4 + 2.89 \cos^2(T - 19^\circ)} \quad (21)$$

where T is the target ship position ($0^\circ \leq T < 360^\circ$).

The membership function of target position is:

$$u(T) = \begin{cases} \frac{1}{1 + (T/T_0)^2} & , 0 \leq T < 180^\circ \\ \frac{1}{1 + \left(\frac{360^\circ - T}{T_0}\right)^2} & , 180^\circ \leq T < 360^\circ \end{cases} \quad (22)$$

In the formula, T_0 is decided by the ratio of velocity K ,

$$T_0 = \begin{cases} 40^\circ & , K = \frac{V_0}{V_t} < 1 \\ 90^\circ & , K = \frac{V_0}{V_t} = 1 \\ 180^\circ & , K = \frac{V_0}{V_t} > 1 \end{cases} \quad (23)$$

The membership function of $dCPA$ is,

$$u(dCPA) = \begin{cases} 1 & , dCPA \leq \lambda \\ \frac{1}{2} - \frac{1}{2} \sin \left[\frac{\pi}{dCPA_0 - \lambda} \left(dCPA - \frac{dCPA_0 + \lambda}{2} \right) \right] & , \lambda < dCPA \leq dCPA_0 \\ 0 & , dCPA > dCPA_0 \end{cases} \quad (24)$$

In the formula $dCPA_0 = 1$ n mile, $\lambda = 2(L_0 + L_t)$ (safety area), L_0 , L_t are the lengths of local and target ship. Equation (11) is adopted as the membership function of $tCPA$.

The target evaluation matrix is,

$$B = [u_d, u_t, u_{dCPA}, u_{tCPA}]^T$$

$0 \leq u_d \leq 1$, $0 \leq u_t \leq 1$, $0 \leq u_{dCPA} \leq 1$, $0 \leq u_{tCPA} \leq 1$ are the grades of the membership functions, Weightings of the target factors are:

$$A = [a_d, a_T, a_{dCPA}, a_{tCPA}]$$

$a_d > 0$, $a_T > 0$, $a_{dCPA} > 0$, $a_{tCPA} > 0$ and $a_d + a_T + a_{dCPA} + a_{tCPA} = 1$, (Expert recommends: $a_d = 0.12$, $a_T = 0.12$, $a_{dCPA} = 0.38$, $a_{tCPA} = 0.38$)

The collision risk is:

$$CR = a_d u(d) + a_T u(T) + a_{dCPA} u(dCPA) + a_{tCPA} u(tCPA) \quad (25)$$

Yan [33] thought that it was not enough to take the parameters (D , T , $dCPA$, $tCPA$) into account only for col-

lision risk calculation. He used the distance D of two ships, relative position B , $dCPA$, $tCPA$, velocity ratio K and collision angle θ to construct collision risk evaluation model.

Target ship evaluation matrix,

$$R = [r_D, R_T, r_{dCPA}, r_{tCPA}, r_K, r_\theta]^T$$

The distribution of target weightings:

$$A = [a_d, a_T, a_{dCPA}, a_{tCPA}, a_K, a_\theta]$$

$a_d > 0$, $a_T > 0$, $a_{dCPA} > 0$, $a_{tCPA} > 0$, $a_K > 0$, $a_\theta > 0$ and $a_d + a_T + a_{dCPA} + a_{tCPA} + a_K + a_\theta = 1$

He thought that $dCPA$ was the most important factor in collision risk evaluation, the secondary ones were D and $tCPA$. The weightings of factors were adopted as follows:

$$a_d = 0.1, \quad a_T = 0.1, \quad a_{dCPA} = 0.4, \quad a_{tCPA} = 0.2, \quad a_K = 0.1, \quad a_\theta = 0.1.$$

In literature [33], the membership functions are listed as in Table 1.

The formula in the table: $dCPA_0$ is the threshold of target ship's $dCPA$. The minimal safe passing distance is $dCPA_0$, and r_{dCPA} is 0.5 when $dCPA = dCPA_0$. It is the critical point of safety and danger. The threshold of $tCPA$ is $tCPA_0$. The time from adopting collision avoidance operation to the position of $dCPA_0$ is $tCPA_0$, and R_T is 0.5 when $tCPA = tCPA_0$. The threshold of two-ship's distance D is D_0 , and D_0 is set to the minimal distance of adopting collision avoidance operation D_s , r_D is 0.5 when $D = D_s$. The threshold of relative position T is T_0 , and adopt $T_0 = 19^\circ$ which comes from the Arena; and R_T is 1 when $T = 19^\circ$. The threshold of velocity ratio K is K_0 , and adopt $K_0 = 1$. The threshold of target collision angle θ is θ_0 , and adopt $\theta_0 = 90^\circ$; r_θ is 0.5 when $\theta = 90^\circ$ [33].

The assessment result is that, $C = A \cdot R$

$$CR = a_d r_D + a_T R_T + a_{dCPA} r_{dCPA} + a_{tCPA} r_{tCPA} + a_K r_K + a_\theta r_\theta \quad (26)$$

4.3 Space and time collision risk evaluation

In the encounter of ships, the navigator has different feeling about the distance and time of collision avoidance. Therefore, the collision risk was divided into time collision risk (TCR) and space collision risk (SCR) according to Wu and Zheng [34, 35]. They were

only considered as the effecting factors of collision risk evaluation in the past. The definition of SCR is that: the local ship encounters with another ship with collision risk, it is the measure of collision probability based on the factors of dCPA of target ship, position of CPA, relative position of target ship and minimal safe passing distance. It is the measure of ship collision probability, not urgency of collision. The definition of TCR is that: it is the urgent level of time that ship arrives at the last minute action point when two ships have a collision risk. It is the measure of urgency of collision avoidance. We can understand the collision risk in space and time aspects through the definitions.

In the evaluation of SCR, Stevens's (1962) psychological sense equation was used to construct the SCR. $a = k(\varphi - \varphi_0)^n$ (27) where a is the psychosensorial strength, k is a constant, φ is the stimulation, n is decided by our sense organ, and n is 0.33 for our vision in light, 3.5 in electric shock.

In literature, the membership function of dCPA is,

$$u(dCPA) = \begin{cases} 1 & |dCPA| < d_1 \\ \left(\frac{d_2 - |dCPA|}{d_2 - d_1}\right)^{3.03} & d_1 \leq |dCPA| \leq d_2 \\ 0 & d_2 < |dCPA| \end{cases} \quad (28)$$

$$dCPA = R_T \cdot \sin(\phi_R - \alpha_T - \pi) \quad (29)$$

where R_T is the distance of two ships; ϕ_R is the relative course; α_T is the true bearing of target ship.

$$\rho(\theta_T) = \begin{cases} 1.1 - \frac{\theta_T}{180^\circ} \times 0.2 & , 0^\circ \leq \theta_T \leq 112.5^\circ \\ 1.0 - \frac{\theta_T}{180^\circ} \times 0.4 & , 112.5^\circ < \theta_T \leq 180^\circ \\ 1.0 - \frac{360^\circ - \theta_T}{180^\circ} \times 0.4 & , 180^\circ < \theta_T \leq 247.5^\circ \\ 1.1 - \frac{360^\circ - \theta_T}{180^\circ} \times 0.4 & , 247.5^\circ < \theta_T \leq 360^\circ \end{cases} \quad (30)$$

$$d_1 = 1.5\rho(\theta_T) \quad (31)$$

$$d_2 = 2 \cdot d_1 \quad (32)$$

In literature [34], the calculation of tCPA is the following equation:

$$tCPA = R_T \cos(\phi_R - \alpha_T - \pi) / V_R \quad (33)$$

where R_T is the distance of two ships, ϕ_R is the relative course, α_T is the true bearing of target ship, and V_R is relative velocity.

$$u(tCPA) = \begin{cases} 1 & tCPA \leq t_1 \\ \left(\frac{t_2 - |tCPA|}{t_2 - t_1}\right)^{3.03} & t_1 < tCPA \leq t_2 \\ 0 & tCPA > t_2 \end{cases} \quad (34)$$

In the formula, t_1 is the same as Equation (12), t_2 the same as Equation (13). In daily life, humans feel danger in the premise of discovering the target. If the navigator does not find the ship, there will be no danger in common. So, define the distance of two ships 12 n miles as the critical value, namely d_2 is 12

n miles, if the distance of two ships is bigger than 12 n mile, TCR will be 0. Finally, combine SCR and TCR into a collision risk.

4.4 Simulation test

In order to compare these evaluation methods based on dCPA and tCPA, a crossing encounter situation simulation is carried out. The parameters of ships are, local ship: the position (0, 0), course 000°, velocity 15 kn, length 250 m, visibility is better (K1=1, K2=1, K3 =1), adopt DLA=1 n mile, and the target ship: the position (7, 7), course 250°, velocity 25 kn, length 110 m. The movements of ships are simulated, and the two ships have an encounter situation. If there are no collision avoidance measures, the two ships will have a collision as in Figure 15. According to the Zheng, Liu and Wu's collision risk evaluation methods, the collision risk evaluation results are shown in Figure 16.

Figure 16 shows that the collision risk is bigger and bigger with the decrement of relative time (R_T). The collision risk begins to increase fast when the R_T is 3 n miles. The collision risk is about 1 when R_T is

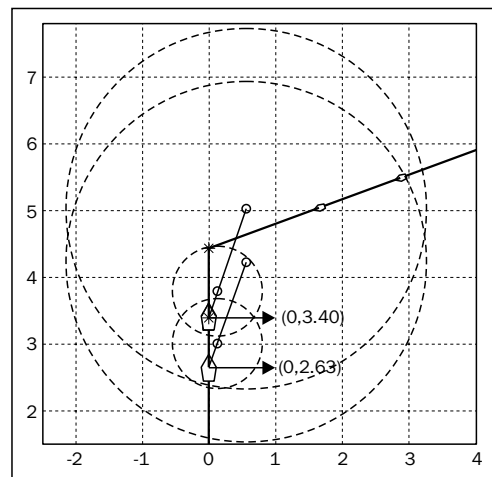

Figure 15 - Encounter situation of two ships

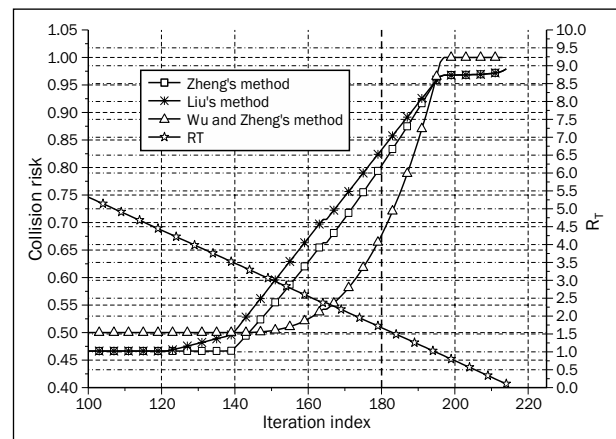

Figure 16 - Collision risk evaluation results without collision avoidance measures

1 n miles. The incensement of Zheng and Liu's method is linear, while Wu and Zheng's method is non-linear.

If there is a collision avoidance measure by steering 11 degrees, the collision avoidance process is shown in Figure 17. The minimal distance of two ships is 1,105 m in the collision avoidance process as shown in Figure 17.

From Figure 18 we know, there are two processes for R_T in the collision avoidance process. Therefore, the collision risks have two processes, reaching the maximum and falling down. The collision risks reach the maximum and then fall down quickly for Zheng and Liu's method, though the R_T value is small. The maximal collision risk of Wu and Zheng's will keep for a while until R_T recovers. There are more parameters involved in Zheng and Liu's method than Wu's method; this is why the collision risk does not maintain higher value in the collision avoidance process. However, the psychological factor of navigator is considered more in Wu and Zheng's method. Therefore, the distance is the main factor reflecting the feeling of navigator, and collision risk keeps a maximal value for a while until R_T is bigger.

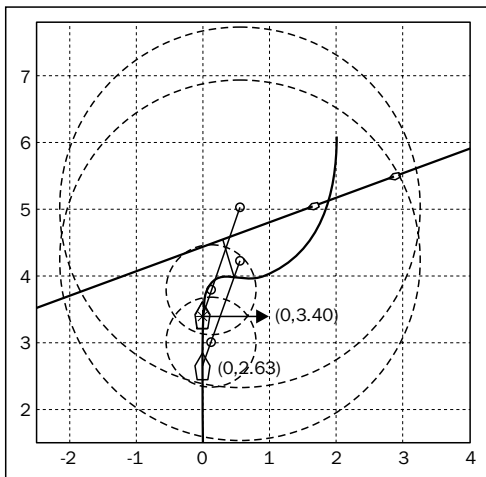

Figure 17 - Collision avoidance process

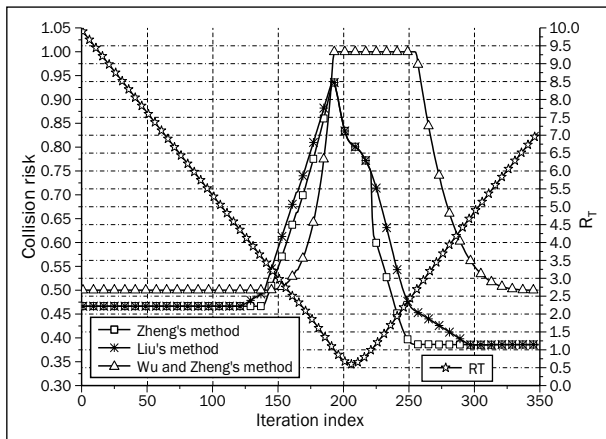

Figure 18 - Collision risk evaluation results by steering 11 degrees by collision avoidance measures

5. OTHER METHODS

There are also other methods to evaluate the collision risk. Smierzchalski [36] presented an intelligent control system of ship motion in the situation of threat with collision. The goal of the system is to support the navigator in decision-making. Evolutionary algorithm is used to mark the optimum path of passages and fuzzy logic is used to control the ship after a set path of passage. Liu and Shi [37] proposed a fuzzy-neural inference network for ship collision avoidance. The model had three subnets, each subnet being independent. Subnet 1 is used to classify the encounter situation and collision avoidance action, subnet 2 for calculation speed ratio membership functions and subnet 3 for inference alteration magnitude and action time. The inputs of subnet 1 and subnet 2 were those data coming from the user and other equipment by respective interface to describe the current ship encounter situation, while their outputs (after being processed) were taken as inputs of subnet 3. These final outputs of subnet 3 were decisions for collision avoidance of the time. There are also other ways based on the fuzzy theory. Wang [38] proposed a Dynamic Quaternion Ship Domain (DQSD) models. The DQSD model is able to capture essential subjectivity and objectivity of ship domains which could sufficiently consider ship, humans and circumstance factors. Wen [39] made use of the Probit model to assess the collision risk for the ship in channel, where the dCPA and tCPA are not the most important parameters comparing with velocity of wind and visibility, etc.

6. CONCLUSION

This study provides an understanding about the collision risk evaluation and the theoretical background of the related work. The classical techniques are based on the mathematical models while the modern techniques are based on artificial intelligence (AI). The areas of AI for ship collision risk evaluation are fuzzy logic, expert systems, and neural networks (NN), as well as their combination (hybrid system). The collision risk evaluation methods are cross-development from the beginning, such as Fujii and Goodwin proposed the mathematical model for collision risk evaluation in 1973 and 1978 separately, and the ship domain was proposed in 1975.

The method based on the traffic flow theory is developed first. It is suitable for traffic investigation, and subsequent investigation. It takes human behaviour little into consideration. The assessment needs massive data from history data, experiment and traffic investigation. This may waste man-power, labour resources, and financial resources, and cannot obtain the creditable result in short-term due to the changing

effect factors. In collision avoidance system, ship domain and methods based on dCPA and tCPA are used frequently due to its characteristics. The ship domain is mainly human's feeling about the distance of ships. Ship domains come from the investigation of navigators. So it has the characteristic of subjectivity. The use of dCPA and tCPA in collision risk evaluation adds more objectivity to collision avoidance. They are evolutionary with the development of technology. Like using the fuzzy theory in collision risk evaluation, the input of fuzzy system can be fuzzy variable; this can indicate the process of human's decision-making, and make use of human's experience. Researchers are increasingly taking AI technology into collision risk evaluation system.

Ship collision avoidance is a complex multi-task problem. The navigator can only predict the encounter status according to the dCPA, tCPA and previous trajectory with the help of ARPA, and then select the proper operation. Human's critical decisions are highly subjective and may lead to error and potentially ship collision avoidance. Therefore, we can make use of the ship intelligent decision support systems to overcome or, reduce the subjective nature of humans as much as possible which is the aim of collision risk evaluation. In the intelligent decision-support system, the ship domain, ship arena and collision risk can be evaluated automatically. The system can analyse the effect of the navigator's operation, and select a better operation.

ACKNOWLEDGEMENT

This work is supported by the National Natural Science Foundation of China (under Grant 51009017, 61174044), Applied Basic Research Funds from Ministry of Transport of P. R. China (under Grant 2012-329-225-060), China Postdoctoral Science Foundation (under Grant 2012M520629).

许庆阳 王宁

摘要

船舶碰撞危险度估计方法研究综述

近年来,由于化学品船、VLCC(大型油轮)等超大型船舶的出现,船舶避碰变得异常重要。当前,船舶安全航行所需要的信息主要源于船员瞭望及电子设备所获信息。然而,根据船舶碰撞相关研究数据表明,决策错误以及驾驶人员的操作失误是导致事故的主要原因。船舶避碰支持系统是一个有利的辅助工具,在船舶避碰支持系统中,碰撞危险度的估算是一个重要研究课题。本文对船舶航行中不同的船舶碰撞危险度估算方法进行了综述。文中对船舶碰撞危险度的基本概念的定义以及其发展历程进行了阐述。本文主要对三种船舶碰撞危险度估计模型进行了阐述:基于交通流的估算方法,基于船舶领域以及基于dCPA与tCPA估计的方法。

关键词

碰撞危险度; 避碰; 船舶领域; 模糊综合评判

REFERENCES

- [1] Corovic BM, Djurovic P. *Research of marine accidents through the prism of human factors*. Promet-Traffic & Transportation. 2013;25(4):369-377.
- [2] Rudan I, Komadina P, Ivče R. *Officers' Subjective Near Miss Notion in Situations of Collision Avoidance at Sea*. PROMET-Traffic&Transportation. 2012;24(4):317-322.
- [3] Tam C, Bucknall R. *Collision risk assessment for ships*. Journal of Marine Science and Technology. 2010;15(3): 257-270.
- [4] Cockcroft AN. *The Estimation of Collision Risk for Marine Traffic*. Journal of Navigation. 1981;34(01):145-147.
- [5] Goodwin EM. *Marine encounter rates*. Journal of Navigation. 1978;31(03):357-369.
- [6] Fujii Y, Yamanouchi H. *The distribution of collisions in Japan and methods of estimating collision damage*. Journal of Navigation. 1973;26(01):108-113.
- [7] Barratt MJ. *Encounter rates in a marine traffic separation scheme*. Journal of Navigation. 1973;26(4):458-465.
- [8] Brok JFC, van der Vet RP. *A Method for the Analysis and Processing of Marine Collision Data*. The Journal of Navigation. 1984;37:49-59.
- [9] Fujii Y, Tanaka K. *Traffic capacity*. Journal of Navigation. 1971;24(4):543-552.
- [10] Coldwell TG. *Marine traffic behaviour in restricted waters*. Journal of Navigation. 1983;36(3):430-444.
- [11] Goodwin EM. *A statistical study of ship domains*. Journal of Navigation. 1975;28(03):328-344.
- [12] Davis PV, Dove MJ, Stockel CT. *Computer simulation of multi-ship encounters*. Journal of Navigation. 1982;35(2):347-352.
- [13] Davis PV, Dove MJ, Stockel CT. *A computer simulation of marine traffic using domains and arenas*. Journal of Navigation. 1980;33(1):215-222.
- [14] Švetak J. *Estimation of ship domain zone*. PROMET-Traffic&Transportation. 2009;21(1):1-6.
- [15] Zadeh LA. *Fuzzy sets*. Information and control. 1965;8(3):338-353.
- [16] Zhao J, Wu Z, Wang F. *Comments on ship domains*. Journal of Navigation. 1993;46(03):422-436.
- [17] Pietrzykowski Z. *Ship's Fuzzy Domain – a Criterion for Navigational Safety in Narrow Fairways*. Journal of Navigation. 2008;61(03).
- [18] Smierczalski R, Michalewicz Z. *Modeling of ship trajectory in collision situations by an evolutionary algorithm*. IEEE Transactions on Evolutionary Computation. 2000;4(3):227-241.
- [19] Pietrzykowski Z. *The analysis of a ship fuzzy domain in a restricted area*. IFAC Conference on Control Applications in Marine Systems. Glasgow, Scotland; 2002. p. 45-50.
- [20] Szlapczynski R. *A Unified Measure Of Collision Risk Derived From The Concept Of A Ship Domain*. Journal of Navigation. 2006;59(03).

- [21] **Wang N, Meng X, Xu Q, Wang Z.** *A Unified Analytical Framework for Ship Domains.* Journal of Navigation. 2009;62(4):643-655.
- [22] **Švetak J, Jakomin L.** *Model of Optimal Collision Avoidance Manoeuvre on the Basis of Electronic Data Collection.* Promet-Traffic&Transportation. 2005;17(6):295-302.
- [23] *Computer programs for collision avoidance and traffic keeping.* Conference on mathematical aspects of marine traffic. London, UK; 1977. p. 229-242.
- [24] **Imazu H, Koyama T.** *Study on the critical range by course changing manoeuver.* Japan Institute Navigation Journal. 1990;82:77-85.
- [25] **James MK.** *Modelling the decision process in computer simulation of ship navigation.* Journal of Navigation. 1986;39(01):32-48.
- [26] **Hasegawa K, Kouzuki A, Muramatsu T, Komine H, Watabe Y.** *Ship auto-navigation fuzzy expert system (SAFES).* Journal of the Society of Naval Architecture of Japan. 1989;166.
- [27] **Yao J, Fang X, Wu Z.** *Comparative Studies of the Different Ship Collision Risk Assessment Systems.* Journal of Dalian Fisheries University. 1999;14(1):37.
- [28] **Sii HS, Ruxton T, Wang J.** *A fuzzy-logic-based approach to qualitative safety modelling for marine systems.* Reliability Engineering & System Safety. 2001;73(1):19-34.
- [29] **Hwang C.** *The Integrated Design of Fuzzy Collision-Avoidance and H[infty infinity]-Autopilots on Ships.* Journal of Navigation. 2002;55(1):117-136.
- [30] **Yao J, Ren Y, Wu Z, Fang X.** *Fuzzy identification method for collision risk assessment of multi-ships encounter situation.* Journal of Dalian Fisheries University. 2002;17(4):313-317.
- [31] **Liu Y, Sun H.** *A Risk-Degree Model of Collision Based on Fuzzy Theory.* Navigation of China. 1998;43(2):23-29.
- [32] **Zheng D.** *Judge of criticality when watercraft encounters.* Journal of Dalian Maritime University. 2002;28(2):14-17.
- [33] **Yan Q.** *A Model for Estimating the Risk Degrees of Collisions.* Journal of Wuhan University of Technology (Transportation Science & Engineering). 2002;26(2):220-222.
- [34] **Wu Z, Zheng Z.** *Time collision risk and its model.* Journal of Dalian Maritime University. 2001;27(2):1-5.
- [35] **Zheng Z, Wu Z.** *Space collision risk and its model.* Journal of Dalian Maritime University. 2001;27(4):1-4,10.
- [36] **Szlapczynski R.** *Evolutionary Sets of Safe Ship Trajectories Within Traffic Separation Schemes.* Journal of Navigation. 2013;66(1):65-81.
- [37] **Liu YH, Shi CJ.** *A fuzzy-neural inference network for ship collision avoidance.* Proceedings of 2005 International Conference on Machine Learning and Cybernetics. 2005;4754-4759.
- [38] **Wang N.** *A Novel Analytical Framework for Dynamic Quaternion Ship Domains.* Journal of Navigation. 2013;1(1):1-17.
- [39] **Chin HC, Debnath AK.** *Modeling perceived collision risk in port water navigation.* Safety Science. 2009;47(10):1410-1416.