

Primljen / Received: 20.6.2014.

Ispravljen / Corrected: 2.10.2014.

Prihvaćen / Accepted: 15.10.2014.

Dostupno online / Available online: 10.11.2014.

# Evaluation of extreme load performance of pre-Northridge connections

## Authors:



**Iman Faridmehr**, PhD. CE  
Universiti Teknologi Malaysia  
Faculty of Civil Engineering  
UTM Construction Research Centre  
[s.k.k-co@live.com](mailto:s.k.k-co@live.com)



Assoc.Prof. **Mohd Hanim Osman**  
Universiti Teknologi Malaysia  
Faculty of Civil Engineering  
Dep. of Structure and Material  
[mhanim@utm.my](mailto:mhanim@utm.my)



Assoc.Prof. **Mamood Md. Tahir**  
Universiti Teknologi Malaysia  
Faculty of Civil Engineering  
UTM Construction Research Centre  
[mahmoodtahir@utm.my](mailto:mahmoodtahir@utm.my)



**Ali Farokhi Nejad**, MSc. ME  
Universiti Teknologi Malaysia  
Faculty of Mechanical Engineering  
[ali17761@yahoo.com](mailto:ali17761@yahoo.com)



**Reza Hodjati**, MSc. CE  
Universiti Teknologi Malaysia  
Faculty of Civil Engineering  
Dep. of Structure and Material  
[rezahodjati670@gmail.com](mailto:rezahodjati670@gmail.com)

Scientific paper - Preliminary note

**Iman Faridmehr, Mohd Hanim Osman, Mamood Md. Tahir, Ali Farokhi Nejad, Reza Hodjati**

## Evaluation of extreme load performance of pre-Northridge connections

Disastrous consequences of a partial collapse of the Ronan Point apartment in 1968, along with the 1994 Northridge earthquake, exposed the vulnerability of steel moment frames subjected to extreme loading. The reports of these two catastrophic events revealed the significant role of the beam-to-column connection where the damage was mainly formed. A numerical and experimental investigation was conducted in accordance with 2010 AISC Seismic Provisions and UFC 4-023-03 Guideline. An inadequate cyclic behaviour and rotational capacity resulted from the analysis where the fracture in the vicinity of groove welding was due to a poorly designed connection.

### Key words:

pre-Northridge welded-bolted connection, interstorey drift angle, seismic and progressive collapse performance

Prethodno priopćenje

**Iman Faridmehr, Mohd Hanim Osman, Mamood Md. Tahir, Ali Farokhi Nejad, Reza Hodjati**

## Procjena ponašanja "Pre-Northridge" priključaka na ekstremna opterećenja

Katastrofalne posljedice djelomičnog urušavanja apartmana Ronan Point 1968. i potresa u Northridgeu 1994. razotkrile su osjetljivost čeličnih okvira izloženih ekstremnim opterećenjima. Izvješća ovih dvaju katastrofalnih događaja pokazala su značajnu ulogu priključka nosač-stup gdje su se pretežno događala oštećenja. Numeričko i eksperimentalno istraživanje provedeno je u skladu sa 2010 AISC seizmičkim odredbama i UFC 4-023-03 smjernicama. Nisko ciklično ponašanje i rotacijski kapacitet proizlaze iz analize gdje je lom u blizini sučeonog zavara bio način otkazivanja uzoraka.

### Ključne riječi:

"Pre-Northridge" priključci, međukatni kut zaokreta, ponašanje pri seizmičkom i progresivnom kolapsu

Vorherige Mitteilung

**Iman Faridmehr, Mohd Hanim Osman, Mamood Md. Tahir, Ali Farokhi Nejad, Reza Hodjati**

## Bewertung des Verhaltens von "Pre-Northridge" Verbindungen unter extremen Belastungen

Die katastrophalen Folgen des teilweisen Einsturzes der Wohnung Ronan Point 1968 und des Northridge-Erdbebens 1994 enthüllten die Verletzlichkeit von Stahlrahmenkonstruktionen unter extremen Belastungen. Berichte über diese katastrophalen Ereignisse weisen auf eine bedeutende Rolle der Verbindungen von Trägern und Säulen hin, die den größten Schaden vorzeigten. Numerische und experimentelle Untersuchungen sind nach der AISC seismischen Verordnung 2010 und den UFC 4-023-03 Richtlinien. Die Analysen weisen auf ein schlechtes zyklisches Verhalten und niedrige Rotationskapazität hin, wobei das Versagen in der Nähe der Schweißnaht sich als häufigster Versagensmodus herausstellte.

### Schlüsselwörter:

"Pre-Northridge" Verbindungen, seismisches und progressives Einsturzverhalten

## 1. Introduction

No serious concerns about reliability of the design and construction procedures for steel moment frame connections existed prior to the 1994 Northridge, California, earthquake, which led to initiation of severe damage in beam-to-column joints that experienced rotation levels below the yield capacity of the framing members. This unexpected brittle fracture was in contrast with the intended design philosophy regarding these frames, which anticipated energy dissipation through formation of ductile plastic hinges in steel beams. Therefore, the behaviour of fully restrained connections has been closely investigated by researchers ever since. A research on seismic performance of steel moment frames was conducted by the SAC Joint Venture, and funded by the Federal Emergency Management Agency, FEMA [1], in the United States. Thus, a series of reports such as FEMA 350 [2] and FEMA 351 [3] was published with respect to seismic design of steel beam - column connections. MD Engelhardt and AS Husain [4] carried out cyclic load tests on eight full-scale pre-Northridge connections. The objective was to investigate the need for supplemental welds on the beam web connections. The results indicated that plastic rotations developed by the beams prior to connection failure were poor when all connections failed by fracture at or near the beam flange groove welds. In 2005, Chen and Cheng-Chih et al [5] investigated experimentally and numerically the cyclic behaviour of pre-Northridge connections. The experimental results explicitly revealed the brittle fracture of the beam flange, initiated from the root of the weld access hole. Moreover, the stress concentration in the weld access hole region had the potential to cause the beam flange fracture during numerical analysis. Accordingly, the seismic performance of pre-Northridge steel frame buildings has been widely investigated [6-8]. These studies were aimed at investigating the effects of connection failure on structural response of steel buildings in case of an earthquake action. Premature fractures were observed in all investigations, and the types of fractures were similar to those observed in the field following the earthquake. At present, test protocols designated in Appendix S of the AISC Seismic Provisions [9] are used to undertake the quality acceptance procedure for all moment resisting connections incorporated in special or intermediate steel moment frames. The ability of the connection to withstand large inelastic deformations using controlled ductile yielding in specific behavioural modes is the target of such test protocols.

Similarly, disastrous consequences of partial collapse of the Ronan Point apartment tower in 1968 also raised serious concerns over the resistance of structures to progressive collapse. The 9/11 terrorist attacks which led to the total collapse of the World Trade Centre in 2001 peaked the progressive-collapse-related concerns among scientists. Many papers have so far been published with respect to the progressive collapse phenomenon. Khandelwal, K. and El-Tawil, S. [10] performed a numerical simulation in 2007 to show the number of key design variables that influence the formation of catenary action in special steel-made moment resisting frame sub-assemblages. In another numerical investigation, Jinkoo Kim and Dawoon An [11] studied the effect of catenary action on the

progressive collapse potential of steel moment frame structures. The results show that the maximum deflection caused by sudden removal of a column decreases when the catenary action is taken into account. In addition, a test program on a steel frame subjected to blast was conducted by Karns et al. [12] in 2009. The study included both numerical and experimental evaluations of the behaviour of different beam-column joints subjected to blast. In another study conducted by Chung-Che Chou et al. [13], three moment connections were rehabilitated by welding full-depth side plates between the column face and the beam flange inner side so as to validate rehabilitation performance. The connection performance during progressive collapse has been addressed in several numerical and experimental investigations [12, 14-17]. The most striking result of these investigations is the fact that semi-rigid connections are more vulnerable to progressive collapse than the fully-rigid ones. Moreover, it has been proven that the bending moment will decrease significantly in beams when catenary action occurs. It has gradually become a general practice for engineers to consider progressive collapse resistance in their designs. Some provisions (strategies and rules) regarding the design of buildings against identifiable and unidentifiable accidental actions are given in Eurocode EN 1991-1-7 [18]. Yet, no direct provisions are given in this code regarding the warfare and terrorist activities, external explosions, residual stability of buildings, or other civil engineering related projects that are subject to seismic action or fire, etc. In addition, the UK designers have been considering for more than 26 years possible regulations for the design against disproportionate collapse in case of tall buildings (5 storeys and above). Furthermore, general regulations on the design of structures against progressive collapse are provided in BS 6399 [19], while more specific provisions for steel, concrete and masonry structures are given in BS 5950 [20], BS 8110 [21], and BS 5628 [22], respectively. Generally, three alternative measures are incorporated, sometimes jointly, in European practice for the purpose of achieving structural robustness and reducing the risk of disproportionate collapse. These measures are listed as follows:

- Decreasing the possibility of accidental loading.
- Avoiding propagation of possible initial failure along with increasing redundancy, including the indirect method and the alternative load path method.
- Designing the structure to tolerate accidental loading, also known as the specific load resistance method.

In the US, guidelines issued by the Department of Defence, DoD [23], and General Services Administration guidelines, GSA [24], include detailed methodologies that are aimed at reducing potential for the progressive collapse of structures. The fundamental analysis approach employed in these guidelines is the Alternate Path (AP) method. This approach allows local failure once the structure is subjected to an extreme load; yet, it seeks to provide alternate load paths so that the initial damage can be controlled and the major collapse averted. There is a common perception that seismic detailing can improve

collapse resistance of steel structures. However, a seismic force demands a different type of force in structures compared to progressive collapse. In other words, the effect potentially large catenary tensile forces (developed during progressive collapse) have on connection performance has not as yet been adequately studied. It should be noted that the ability of a connection to resist vertical loads by developing a string-like mechanism is referred to as the catenary action. The vulnerability of pre-Northridge beam to column connections in case of extreme loading is the main objective of this study. Hence, numerical simulations and experimental tests were conducted to study fundamental design variables, especially the plastic rotation angle of the beam to column connections that affect the resistant capacity, and the failure mode of connections in case of cyclic loading and progressive collapse, which in turn is simulated by push-down analyses. Therefore, the interstorey drift angle in accordance with 2010 AISC Seismic Provisions [9], and the plastic hinge rotation limitations prescribed by DoD [23], were the fundamental acceptance criteria for evaluation of the seismic and progressive collapse performance, respectively. The models were scaled down to 1/6th of their real size and set up in the Laboratory of Structures and Materials, Universiti Teknologi Malaysia (UTM). The numerical part was conducted using the FEA software ABAQUS [25].

## 2. Performance of pre-Northridge connections subjected to extreme loading

After the Northridge earthquake, damage reports indicated that prevalence of bottom flange weld fractures in the absence of inelastic beam deformations was evident in the pre-Northridge connection (Figure 1). From an economic point of view, the Northridge Earthquake of 1994 was very costly, and it caused millions of dollars of damage to the building industry.

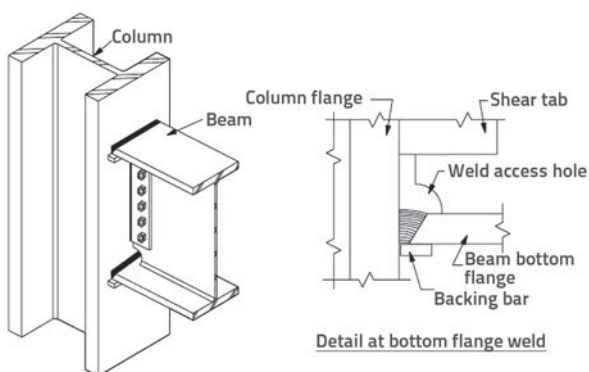

Figure 1. Typical Pre-Northridge welded flange - bolted web moment connection

Hence, extensive research activities have been conducted worldwide to reduce this unexpected damage. Generally, there are two major strategic approaches aimed at improving connection details:

- Strengthening strategy: elements such as cover plates, haunches, side plates, and vertical ribs, are utilized to upgrade or enhance the load carrying capacity of the connection region with respect to that of the base elements (beams or columns). The strategy allows "pushing" a plastic hinge away from the vulnerable connection region.
- Weakening strategy: the most prominent example of this strategy is the Reduced Beam Section or RBS connection, where a beam element (usually flange) is intentionally weakened in bending (by reducing the width of the flanges) to create a "fuse" for ductile yield mechanism without connection failure.

There is an old perception in the structural engineering community that seismically designed structures, such as moment and braced frames, have better resistance to progressive collapse. In other words, there is an implicit assumption that the seismic design and detailing will lead to an enhanced resistance to progressive collapse. In fact, due to lack of design guidelines for progressive collapse, the seismic design is frequently advocated by researchers and practitioners for cases in which prevention of progressive collapse is a design objective, while there is no systematic study to date that would show how the seismic design and detailing influences a structural system's behaviour in a progressive collapse situation. This is an important issue that has to be addressed because seismic forces impose a very different type of demand on a structure, when compared to collapse. For example, the moment frame seismic forces end up in high moment demands in the connection region. However, collapse is associated with high tensile forces, which may adversely influence the performance of seismically designed connections. In a column loss event, the catenary action of beams is highly dependent on the characteristics of connections, as illustrated in Figure 2. Up to now, no sufficient documents have been obtained to reveal that pre-Northridge connections possess sufficient robustness to permit development of plastic rotations at beam ends together with large tensile forces. Therefore, the behaviour of this type of connection under collapse leads to an open issue that requires thorough analysis before such systems could be recommended for progressive collapse scenarios.

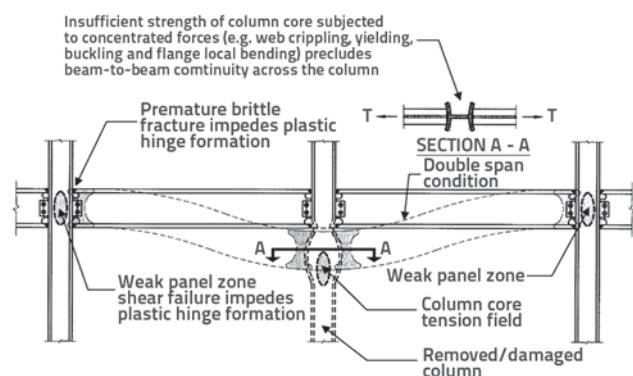
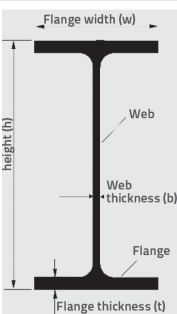

Figure 2. Inability to protect against progressive collapse after loss of column, GSA [19]

Table 1. Beam, column and connection sections selected in this study

Element	Size [mm]	Cross-section	Moment of Inertia [mm <sup>4</sup> ]
<b>Beam Section</b> Height Web thickness Flange width Flange thickness	50 2 40 2		104000
<b>Column Section</b> Height Web thickness Flange width Flange thickness	70 4 70 4		690000

### 3. Research methodology and modelling setup

#### 3.1. Case studies under investigation

The case studies of this research involve two 1/6th-scale beam-to-column connections incorporating I shaped cross-sections subjected to cyclic and push-down tests. The frames were designed according to the requirements contained in the "Specification for Structural Steel Buildings (ANSI/AISC 360-10) [9]. Details of the proposed connection for seismic and progressive collapse assessments are shown in Figure 3 and Table 1.

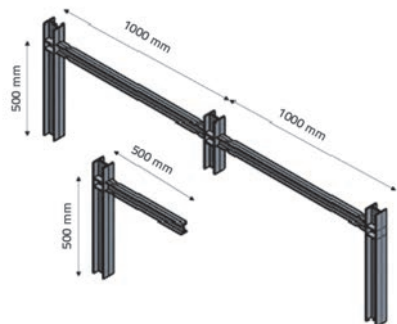

Figure 3. Case studies for seismic and progressive collapse assessments

#### 3.2. Fabrication and modelling setup

The fabrication of test specimens was conducted through collaboration of the university laboratory personnel and commercial fabricators. The Gas Metal Arc Welding (GMAW) process was used in this study. The GMAW, commonly known as the Metal Inert Gas (MIG), is a group of arc welding processes in which powered feed rolls (wire feeder) feed a continuous electrode (the wire) inside the weld pool (Figure 4). By the time the welding process commences, an electric arc is made between the weld pool and the tip of the wire. The melting of the wire is operated in a progressive manner at the same rate at which it is being fed and consequently, the weld pool is implemented. For simultaneous protection of the weld pool and arc against atmospheric contamination, a nozzle concentric with the welding wire guide tube is incorporated to convey a shield of inert (non-reactive) gas. The speed, comparative freedom from distribution, continuity and reliability of automatic welding, as well as the control and versatility of manual welding, are listed as the advantages of this type of welding application. The incorporation of this technique in mechanized set-ups has been rapidly accepted. A handheld gun was used to successfully perform the MIG welding as a semiautomatic process. Since the voltage, speed, arc (stick-out) length, and wire feed rate set to plate thickness, are listed as

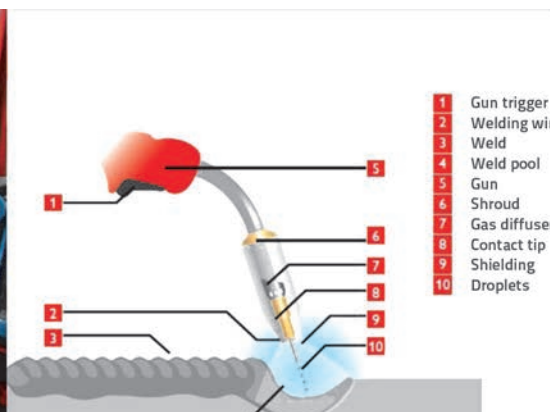

Figure 4. View of welding transfer and accessories

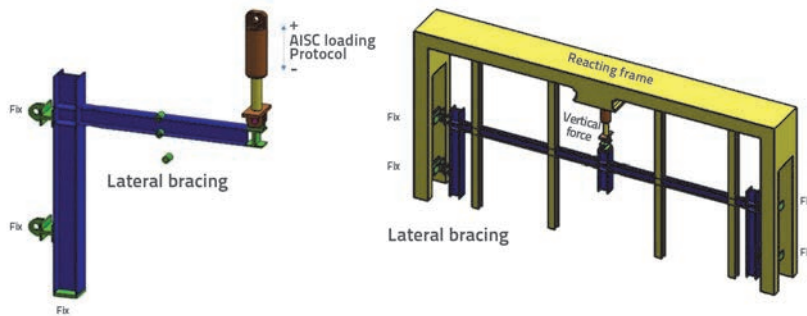

Figure 5. Modelling set up for seismic and progressive collapse assessments



Figure 6. Dynamic actuator and hydraulic jack used for seismic and progressive collapse evaluations

common welding parameters, the filler metal transfer method was determined by the arc voltage and wire feed rate. Once the welding process was completed, lime was used to observe the yielding within the connection region.

The seismic and progressive collapse performance of the 1/6 scale testing specimens was assessed using different loading protocols and lateral restraint assemblies (Figure 5).

The missing column scenario (Alternate Path method) was incorporated as the progressive collapse test method for this study where an instantaneous disastrous event was supposed to destruct the interior column of the structure. In the Alternate Path method, the vertical load was gradually increased using the hydraulic jack on top of the missing column, as shown in Figure 6. Both sides of the beams were laterally restrained at 150 and 800 mm away from the centreline of the specimen column. A 250-KN hydraulic pseudo-dynamic actuator with a maximum piston stroke of 500 mm to the tip of the beam was chosen to conduct and evaluate the cyclic test of the specimens (Figure 6). The middling length of beam from the centreline of the specimen column was the location of lateral restraint of both sides of the beams. A number of strain gauges were installed at predictive hinge locations of steel beams, usually at beam ends, to measure internal forces of the specimens. Linear Variable Differential Transducers (LVDTs) were used to ensure an accurate measurement of vertical deflection of the specimen at the location of the removed column and tip of the beam. In addition, the following assumptions were made in this study:

- The specimens were constrained in plane (two-dimensional tests only). The out-of-plane effect of beams concurring to the joint was neglected.
- The "conservative" approach, based on ignorance of slab effects, was used.

- The initial conditions of the specimens were assumed to be zero stresses resulting from gravity and live loads in addition to zero velocity.

To successfully convert a scaled-down model to a full-scale one, a number of fundamental scaling factors must be used including  $S_E$ , the scaling factor for the material elastic modulus,  $S_\sigma$ , the scaling factor for stress,  $S_l$ , the scaling factor for length,  $S_\epsilon$ , the scaling factor for strain, and finally SM, the scaling factor for mass that is dominantly applied in dynamic simulations. Since the prototype and model in this study are both made of the same steel material, then  $S_E = 1$ , [26]. The following formulas are used to calculate the above mentioned scaling factors:

$$S_l = \frac{\text{prototype length}}{\text{model length}} = \frac{6}{1} = 6 \tag{1}$$

$$S_\epsilon = \frac{S_M}{S_l} = 1 \tag{2}$$

$$S_\sigma = S_E \cdot S_\epsilon = S_E \tag{3}$$

As a result, equations 1 to 3 will be incorporated to calculate all other scaling factors of interest (Table 2).

Table 2. Scale factors to convert results to a full scale model

Quantities	Symbol	Scale factor value
Material-Related Properties		
Modulus of Elasticity	$S_E$	1
Strain	$S_\epsilon$	1
Stress	$S_\sigma$	1
Poisson's Ratio	$\nu$	1
Geometry		
Linear Displacement	$S_l$	6
Area	$S_l^2$	36
Moment of Inertia	$S_l^4$	1296
Elastic & Plastic Section Modulus	$S_l^3$	216
Loading		
Concentrated Load	$S_E S_l^2$	36
Moment or Torque	$S_E S_l^3$	216
Shear Force	$S_E S_l^2$	36

### 3.3. Finite element modelling procedure

The FE software ABAQUS/STANDARD [20] was used in the FEA phase of the study to perform an appropriate modelling of large deformations and strains. The eight-node solid C3D8R element with six degrees of freedom, simultaneously representing three force components and three moment components, was applied to obtain more accurate results from the software model. Furthermore, the true stress-strain curve was used to properly model behaviour of the material [27]. The following formulas are used to determine displacements and strains for a FEA representation:

$$e = \frac{\Delta l}{l} \tag{4}$$

$$S = \frac{P}{A_0} \tag{5}$$

$$\sigma = S (1+e) \tag{6}$$

$$\varepsilon = \ln (1+e) \tag{7}$$

where  $\sigma$  and  $\varepsilon$  are the true stress and strain values determined from equations 6 and 7, while  $e$  and  $S$  are the engineering strain and stress values, respectively, as obtained from the uniaxial tensile test (equations 4 and 5). True and engineering stress-strain curves, and the universal testing machine used in the testing, are shown in Figure 7.

The yield stress, ultimate tensile strength, and elongation values obtained during the tensile strength testing amounted to 320 MPa, 510 MPa, and 18 %, respectively. Material properties of the sheet steel plate used in this research are similar to Grade 50 according to American standard ASTM A572-07. Notice that this grade is equivalent to European standard S420M/EN 10025-4. In all the FEA cases, and at all degrees of freedom, the column base was fixed and the load was applied by controlling displacement in vertical directions. The quasi static loading at the rate of 2mm/s was chosen for the testing. The hex element

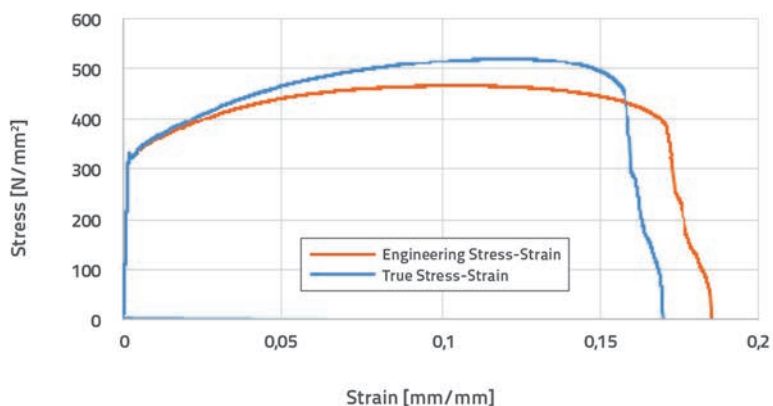

Figure 7. Material properties for true stress-strain and engineering stress-strain curves (left), universal testing machine (right)



was used in all models so as to ensure a finer size mesh for the model.

### 3.4. Loading protocol

The 2010 AISC Seismic Provisions [9] were considered in selecting the loading sequence for this study. The series of load steps, and the number of cycles needed for each step, are specified in the AISC Protocol (Figure 8). Each load step corresponds to the total interstorey drift angle. The testing began by application of load steps, and by recording the data points at regular intervals. By the time each load step was completed, appropriate observations were recorded. The loading was stopped as soon as the strength of the specimen reduced to 40 percent of the maximum strength. On the other hand, the vertical push-down analysis was performed by gradually increasing vertical displacement at the location of the removed column in order to study the rotational capacity of the connection, and the structure’s resistance to this deformation.

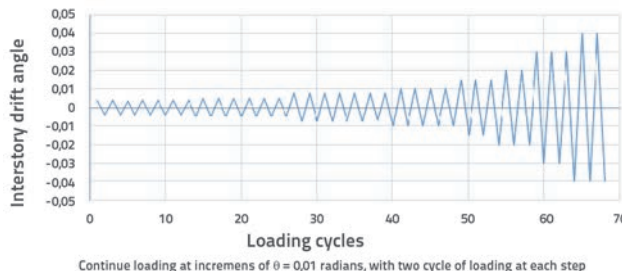

Figure 8. Loading protocol used for seismic assessment

### 3.5. Acceptance criteria based on AISC 341-10 and UFC 4-023-03

Based on AISC Seismic Provisions [9], the SMF shall be designed to provide the significant inelastic drift capacity through flexural yielding of the SMF beams, and limited yielding of the column panel zones. Furthermore, columns shall be designed to be

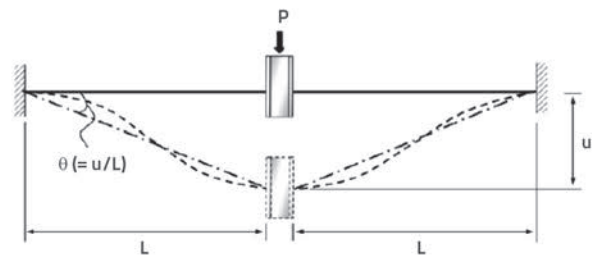
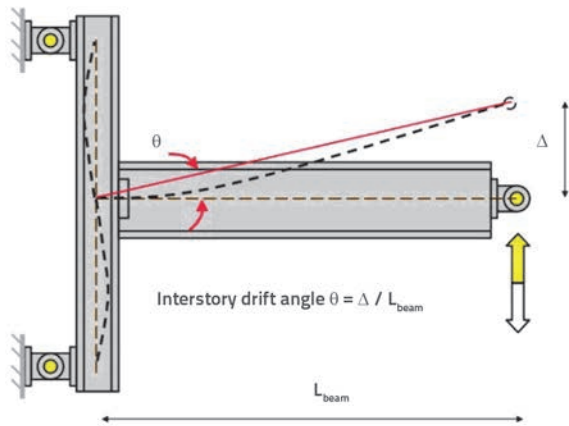

Figure 9. Definition of interstorey drift angle and connection rotation capacity

generally stronger than the fully yielded and strain-hardened beams or girders. Finally, the following seismic requirements were to be satisfied by the proposed connection:

- The interstorey drift angle of at least 0.04 rad must be sustained by the connection (Figure 9).
- The flexural resistance of the connection calculated at the column face must be equal to at least  $0.80 \cdot M_p$  of the connected beam at an inter storey drift angle of 0.04 rad, where  $M_p$  is plastic moment.

An adequate rotational capacity of connections is fundamental for the prevention of progressive collapse (Figure 9). Moment connections that have been prequalified for rotational capacity due to bending alone may not be able to concurrently resist the interaction of axial tension and bending moment, which is an essential performance attribute for preventing progressive collapse. While the tension stiffness ("cable-like" action) can significantly increase the load carrying capacity of the system over bending moment alone, the beam-to-column connection must be able to transfer the large flange tension forces developed from the combination of bending moment and axial tension. Table 5-2 from the UFC 4-023-03 [23] highlights the design strength and rotational capacities of the beam-to-column connections that

are used in the assessment of progressive collapse. Acceptance criteria of the resistance of beam to column connections to progressive collapse are presented in Table 3.

Table 3. Acceptance criteria for fully restrained moment connections

Connection type	Plastic rotation angle ( $\theta$ ), [rad]	
	Primary element	Secondary element
Welded unreinforced flange (WUF)	$0,0284 - 1,57 \cdot 10^{-5} d$	$0,043 - 2,36 \cdot 10^{-5} d$

$d$  = depth of beam, in mm

## 4. Results and discussion

### 4.1. Progressive collapse assessment

Results of the FEA and experimental phases of this study are presented in this section. The main variable in the assessment of the progressive collapse phenomenon is the plastic rotation angle ( $\theta$ ), which is defined as the vertical deflection of the column ( $u$ ) divided by the clear span length of the beam ( $L$ ) (Figure 9).



Figure 10. Specimen damage at the end of progressive collapse test and plastic equivalent strain distribution

Table 4. Summary of progressive collapse evaluation results

Vertical force at first fracture [kN]		Maximum vertical force at the end of test [kN]		Joint rotation at first fracture [rad]		Joint rotation at the end of the test [rad]		Mode of failure	
Analysis	Test	Analysis	Test	Analysis	Test	Analysis	Test	Analysis	Test
6,9	6,2	7,8	7,1	0,005	0,004	0,018	0,014	Connection Failure	Connection Failure

The fracture of the groove welding between the beam flange and column face at the tension side of the beam, along with further propagation of the beam web cracking, was the governing failure mode according to experimental assessment. The specimen was capable of resisting the vertical load of 6 kN prior to initiation of the groove weld fracture. Strain gauges placed at the beam flange did not record strains higher than 1800  $\mu\epsilon$  (micro-strain), which pointed to the limited performance of the connection to develop catenary action. The connection resisted the plastic rotation angle of 0.015 rad prior to severe degradation and, therefore, the specimen did not meet the DoD guideline requirements [23]. The damaged state of the specimen, and the plastic equivalent strain distribution after the final stage of the progressive collapse test, is shown in Figure 10.

The numerical and experimental visualized plots of vertical load, versus the plastic hinge rotation angle of the progressive collapse tests for specimens, are shown in Figure 11. According to Figure 11, there is a good correlation between the experimental and numerical results in terms of the yield point, strain hardening and mode of failure. However, there is an obvious difference for maximum plastic hinge rotations between the FEA and experimental testing. This shows that different behaviour of

welding in the numerical and experimental phase of the study is the cause of such difference in performance. Hence, it could be concluded that the performance of RBS connection was strongly dependent on the groove welding.

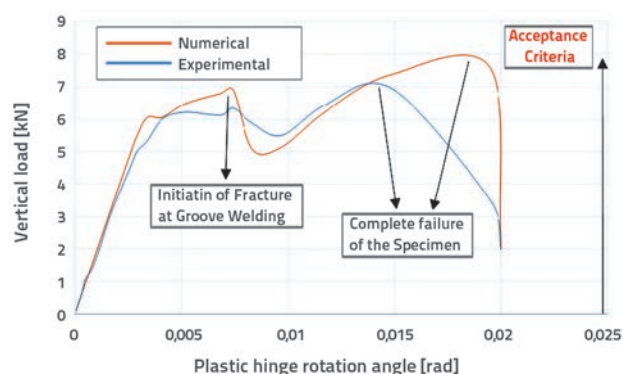

Figure 11. Vertical load vs. plastic hinge rotation angle for progressive collapse tests

A comparison between the numerical and experimental results of the progressive collapse performance of the RBS connection is presented in Table 4.

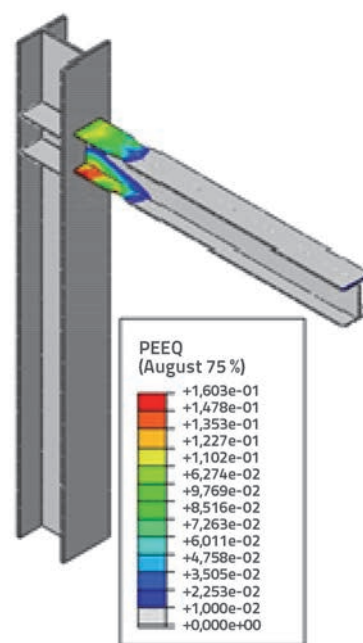
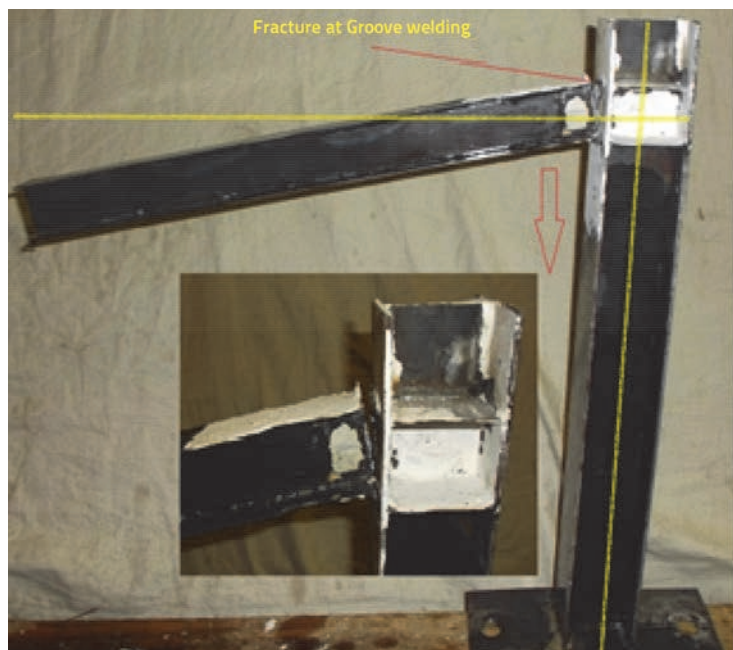

Figure 12. Specimen damage at the end of cyclic test (left), plastic equivalent strain distribution (right)



Table 5. Summary of seismic evaluation results

$M / M_p$ first fracture		$M / M_p$ Maximum		Interstorey drift angle at first fracture [rad]		Interstorey drift angle at the end of the test [rad]		Mode of failure	
Analysis	Test	Analysis	Test	Analysis	Test	Analysis	Test	Analysis	Test
0,71	0,65	0,74	0,68	0,015	0,01	0,027	0,023	Connection Failure	Connection Failure

$M_p$  - Plastic moment

## 4.2. Seismic Assessment

Seismic performance of connections is discussed in this section. The interstorey drift angle, considered as a fundamental parameter in the investigation of seismic performance, is shown in Figure 9. A poor specimen performance under cyclic loading was reported. Although it was anticipated that the plastic hinge will form at the beam, the welding fracture was the actual failure mode of the specimen. At the first stage of failure, the groove welding showed early or brittle fracture at an interstorey drift angle of 0.01 rad. Progressing through the loading history, the propagation of the weld fracture along the groove welds of the beam flange and the column face was initiated. During the cycle of 0.018 rad, an increase in the crack length of up to 1 mm was observed, which led to severe strength degradation. Strain gauges placed on beam flanges showed records lower than  $1800 \mu\epsilon$  (micro-strain), which is an indication of limited performance of the connection to develop fully plastic capacity of the connecting beam. Specimen damage at the end of the cyclic test, and plastic equivalent strain distribution, are shown in Figure 12.

Moments computed at the column face versus the interstorey drift angles, are recognized as the global cyclic response of the specimen shown in Figure 13. Numerical modelling and experimental testing results were in good agreement as to the overall cyclic behaviour.

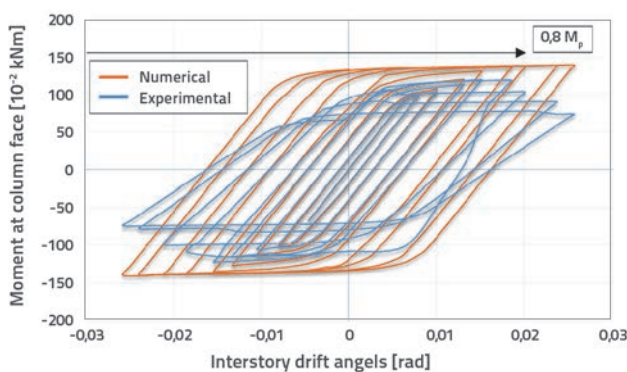

Figure 13. Moments at column face versus interstorey drift angles

Notice that the constitutive model for the material behaviour prediction was an elasto-plastic model, and the simulation was

continued until degradation by damage. Accordingly, stiffness degradation cannot be seen numerically in contrast with experimental testing, where stiffness degradation was related to the localisation of damage in the welding zone. Besides, numerical results also confirmed the formation of plastic hinges in the vicinity of groove welding. Therefore, the vulnerability of groove welds to probable fractures was increased.

A comparison between the recorded experimental (test) and numerical (analysis) results of the seismic evaluation of the connection is presented in Table 5.

## 5. Summary of findings and concluding remarks

Seismic and progressive collapse performance of the Pre-Northridge connection was investigated in this study. The fundamental acceptance criteria for seismic and progressive collapse evaluation incorporated in this study include the interstorey drift angle and flexural strength based on 2010 AISC Seismic Provisions [9], and the plastic rotation angle in conformance with UFC 4-023-03 [23] guideline, respectively. The following conclusions can be made based on the numerical and experimental results obtained in this study:

- The numerical and experimental results prove that the fracture at the groove weld between the beam-to-column interfaces is the failure mode of the specimen during the push-down analysis, where it resisted only the plastic rotation angle of 0.015 rad prior to severe degradation. Moreover, this result points to the limited performance of the connection in developing the full inelastic capacity of the connecting beam. Based on the above mentioned results, the connection does not qualify for resisting progressive collapse in accordance with UFC 4-023-03 guidelines.
- According to cyclic results, the connection exhibits poor performance and does not meet requirements given in 2010 AISC Seismic Provisions, as it resists only an interstorey drift angle of 0.02 rad. Furthermore, the increased vulnerability of groove welds to possible fractures results from concentration of plastic strains in the vicinity of groove welds, which is against its intended design philosophy.
- According to progressive collapse data, the failure mode and the formation of catenary action, are controlled by the tensile capacities of the beam-column joint after large rotations. This indicates that a high tensile resistance must

be adopted for beam-column joints, instead of pure tying resistance, once the joints undergo large rotations. If large rotations are not taken into account at the design phase, the joints with poor rotation capacities will not be able to achieve the preferred design tying resistances.

- The beam to column connection experienced high moment demands and high tensile forces during the cyclic and push-down analyses, respectively. Nevertheless, seismic detailing will eventually improve resistance to progressive collapse.
- The seismic rehabilitation of pre-Northridge connections is a must for existing buildings. Welding a haunch beneath the beam, and a pair of rib plates beneath the beam top flange,

would be a good strategy in this scenario. It is anticipated that this strategy could effectively reduce the plastic strain demand in the groove welded joint of the beam top flange.

## Acknowledgements

The authors wish to thank the esteemed technical staff of the Laboratory of Structures and Materials, Universiti Teknologi Malaysia (UTM) for their cooperation and support in this study. The financial support provided by Universiti Teknologi Malaysia (UTM) for the conduct of experimental work is also appreciated.

## REFERENCES

- [1] Agency, F.E.M., *Federal Emergency Management Agency*, U.D.o.H. Security, Editor. 2002: United States of America.
- [2] Agency, F.E.M., *Recommended Seismic Design Criteria for New Steel Moment-Frame Buildings "FEMA 350"*, U.D.o.H. Security, Editor. 2000: United States of America.
- [3] Agency, F.E.M., *Recommended Seismic Evaluation and Upgrade Criteria for Existing Welded Steel Moment-Frame Buildings "FEMA 351"*, U.D.o.H. Security, Editor. 2000: United States of America.
- [4] Engelhardt, M., Husain, A.: *Cyclic-loading performance of welded flange-bolted web connections*. Journal of Structural Engineering, 1993. 119 (12): pp. 3537-3550.
- [5] Chen, C.-C., et al. : *Cyclic behaviour of unreinforced and rib-reinforced moment connections*. Journal of Constructional Steel Research, 2005. 61 (1): pp. 1-21.
- [6] Wang, C.-H., Wen, Y.-K.: *Evaluation of pre-Northridge low-rise steel buildings. I: Modeling*. Journal of Structural Engineering, 2000. 126 (10): pp. 1160-1168.
- [7] Whittaker, A., Gilani, A., Bertero, V.: *Evaluation of pre-Northridge steel moment-resisting frame joints*. The Structural Design of Tall Buildings, 1998. 7 (4): pp. 263-283.
- [8] Lee, K., Foutch, D.A.: *Seismic performance evaluation of pre-Northridge steel frame buildings with brittle connections*. Journal of Structural Engineering, 2002. 128 (4): pp. 546-555.
- [9] Specifications, A.C.o., *Specification for Structural Steel Buildings (ANSI/AISC 360-10)*. 2010, American Institute of Steel Construction, Inc.
- [10] Khandelwal, K., El-Tawil, S.: *Collapse behavior of steel special moment resisting frame connections*. Journal of Structural Engineering, 2007. 133 (5): pp. 646-655.
- [11] Kim, J., An, D.: *Evaluation of progressive collapse potential of steel moment frames considering catenary action*. The structural design of tall and special buildings, 2009. 18 (4): pp. 455-465.
- [12] Karns, J.E., et al.: *Behaviour of varied steel frame connection types subjected to air blast, debris impact, and/or post-blast progressive collapse load conditions*. Austin, TX, United States, 2009: pp. 1868-1877.
- [13] Chou, C.C., et al.: *Seismic rehabilitation performance of steel side plate moment connections*. Earthquake Engineering & Structural Dynamics, 2010. 39 (1): pp. 23-44.
- [14] Liu, J.: *Preventing progressive collapse through strengthening beam-to-column connection, Part 1: Theoretical analysis*. Journal of Constructional Steel Research, 2010. 66 (2): pp. 229-237.
- [15] Lee, C.-H., et al.: *Simplified nonlinear progressive collapse analysis of welded steel moment frames*. Journal of Constructional Steel Research, 2009. 65 (5): pp. 1130-1137.
- [16] Liu, Y., Xu, L., Grierson, D.E.: *Influence of Semi Rigid Connections and Local Joint Damage on Progressive Collapse of Steel Frameworks*. Computer Aided Civil and Infrastructure Engineering, 2010. 25 (3): pp. 184-204.
- [17] Kim, T., Kim, J.: *Collapse analysis of steel moment frames with various seismic connections*. Journal of Constructional Steel Research, 2009. 65 (6): pp. 1316-1322.
- [18] EN 1991-1-7. Eurocode 1 - EN 1991-1-7: Actions on structures - Part 1-7: General actions - Accidental actions, 2006.
- [19] BS 6399. BS 6399: Loading for buildings: Part 1: Code of practice for dead and imposed loads. British Standards Institute, 1996.
- [20] BS 5950. BS 5950: Structural use of steelwork in building: Part 1: Code of practice for design - Rolled and welded sections. British Standards Institute, 2000.
- [21] BS 8110. BS 8110: Structural use of concrete: Part 1: Code of practice for design and construction. British Standards Institute, 2000.
- [22] BS 5628. BS 5628: Code of practice for use of masonry: Part 1: Structural use of unreinforced masonry. British Standards Institute, 1978.
- [23] Department of Defense, *Design of Buildings to Resist Progressive Collapse, UFC 4-023-03*. 2010.
- [24] The U.S. General Services Administration, *Progressive Collapse Design Guidelines Applied to Concrete Moment-Resisting Frame Buildings*. 2003: Washington (DC).
- [25] ABAQUS/Standard user's manual. Vol. 1. 2001: Hibbitt, Karlsson & Sorensen.
- [26] Tsitos, A.: *Experimental and Numerical Investigation of the Progressive Collapse of Steel Frames*. Doctor of Philosophy Dissertation, The University at Buffalo, the State University of New York. 2009
- [27] Faridmehr, I., et al.: *Correlation between Engineering Stress-Strain and True Stress-Strain Curve*. American Journal of Civil Engineering and Architecture, 2014. 2 (1): pp. 53-59.