

# Liquefied Natural Gas Ship Route Planning Model Considering Market Trend Change

Jaeyoung Cho<sup>a</sup>, Gino J. Lim<sup>a</sup>, Taofeek Biobaku<sup>a</sup>,  
Selim Bora<sup>b</sup>, Hamid Parsaei<sup>b</sup>

## KEY WORDS

- ~ Liquefied natural gas
- ~ Supply chain
- ~ Ship routing
- ~ Boil-off gas
- ~ Stochastic programming

We consider a new biannual liquefied natural gas (LNG) ship routing and scheduling problem and a stochastic extension under boil-off gas (BOG) uncertainty while serving geographically dispersed multiple customers using a fleet of heterogeneous vessels. We are motivated not only by contract trend changes to shorter ones but also by technological advances in LNG vessel design. The mutual coincidence of both transitions enables developing a new LNG shipping strategy to keep up with emerging market trend. We first propose a deterministic LNG scheduling model formulated as a multiple vehicle routing problem (VRP). The model is then extended to consider BOG using a two-stage stochastic modeling approach in which BOG is a random variable. Since the VRP is typically a combinatorial optimization problem, its stochastic extension is much harder to solve. In order to overcome this computational burden, a Monte Carlo sampling optimization is used to reduce the number of scenarios in the stochastic model while ensuring good quality of solutions. The solutions are evaluated using expected value of perfect information (EVPI) and value of stochastic solution (VSS). The result shows that our proposed model yields more stable solutions than the deterministic model. The study was made possible by the NPRP award [NPRP 4-1249-2-492] from the Qatar National Research Fund (a member of the Qatar Foundation).

a. Department of Industrial Engineering, University of Houston, Houston, TX  
e-mail: [jcho12@uh.edu](mailto:jcho12@uh.edu)

b. Texas A&M University at Qatar, Doha, Qatar  
e-mail: [selim.bora@qatar.tamu.edu](mailto:selim.bora@qatar.tamu.edu)

## 1. INTRODUCTION

Global LNG industry is expected to grow about 40 % until 2016 not only as LNG is highlighted as a clean and efficient energy source than other fossil fuels but also as North America raises shale gas production and Asian demand increases steadily (US Department of Energy, 2005; US Department of Energy, 2014). Traditional LNG contracts have 20-30 years of long term duration which ensures stable energy supply and demand (Hartley et al., 2013). In recent years, however, it has been observed that the portion of short-term contracts and spot demand are rapidly increasing in LNG market (Christiansen et al., 2009). The changing demand pattern is directly relevant to the LNG supply policy to satisfy customers. Accordingly, it is required to review the current LNG transportation strategy.

LNG vessels usually sail in the fully loaded condition or with minimum filling of LNG to cool down the tank temperature because partly loaded vessels can make an adverse sloshing impact to the containment system and vessel structure (Shin, et al., 2003). Thanks to recent advances in ship design technology, newly constructed LNG vessels can voyage without completely filling the tanks (Tessier, 2001; Suvisaari, 2012).

With these supporting reasons, we are looking at the transformation of LNG marine transportation model to catch up with the changing business environment. Next generation of LNG shipping model may need to satisfy multiple customers with different contract durations utilizing various types of LNG vessels with different technological constraints and cargo capacities. If that happens, the total sailing time of a LNG vessel in a route may be longer than the schedule from the current LNG routing model. As a result, one must consider gas loss during the shipment because gas evaporates in proportion to the time of voyage.

As we will describe in the following paragraphs, this paper deals with three problems: 1) LNG inventory routing and scheduling, 2) stochastic or robust optimization modeling of uncertain factors in LNG supply chain, and 3) BOG in a cargo tank. In a previous study, an LNG inventory routing problem was formulated in mixed integer program to satisfy monthly demand considering sales activities and inventory level at the regasification terminal (Grønhaug and Christiansen, 2009). LNG supply chain optimization problems are proposed to decide sailing schedule and vessel assignments. This problem is similar to our study, but it differs as it serves single customer in a route (Andersson et al., 2010). Traditional LNG demand is mostly identified by well-determined long-term contracts, and so annual delivery program is developed with diverse fleet of LNG carriers. However, this model is not suitable to include spot-demand and short-term contracts (Rakke et al., 2011).

LNG supply chain inherently includes numerous uncertain factors. Nevertheless, uncertainty has drawn little attention in the quantitative research community. For example, Bopp

et al. formulated price and demand uncertainty in natural gas distribution using stochastic programming (Bopp et al., 1996). Halvorsen-Weare and Fagerholt (2013) considered sailing time uncertainty in LNG supply chain caused by disruptive weather conditions. Their model was based on historical weather data in 3-12 month time horizon. However, neither of these studies have considered uncertain internal system dynamics of LNG carriers, but mostly focused on the impact from external environments.

We recognized that there are limited items of literature regarding BOG effect in LNG supply chain, which is discussed in this paper. In an early stage of research, the focus was on discovering the characteristics of BOG in a partially filled tank and developing mathematical models (Chatterjee and Geist, 1972). In addition, the occurrence and the effect of BOG on LNG supply chain have been examined dividing the time phases into three categories: loading, unloading and marine transportation (Dobrota, et al., 2013). Although the concept of evaporated gas involving LNG inventory routing problem has been studied, BOG was often considered as a constant (Grønhaug, et al., 2010).

Therefore, the purpose of this paper is to present a new mathematical formulation of LNG routing and scheduling in the form of vehicle routing problem (LNG VRP) that can cover overall contract patterns including long-term, short-term and spot demand. We exploit a fleet of LNG carriers with partial loading and unloading capability of cargoes to serve multiple customers in routes. We especially consider evaporated gas losses during voyage by developing a two-stage stochastic model.

The remaining part of this paper is organized as follows: Section 2 describes the proposed problem. Section 3 provides mathematical formulations of the LNG ship routing and scheduling problem in a deterministic form and stochastic extension considering BOG. Then Section 4 presents the computational study with test case description and settings, numerical results and sensitivity analysis. Finally, the paper is concluded in Section 5.

## 2. PROBLEM DESCRIPTION

This model generates biannual shipping schedule to maximize the profit meeting all customer demands while ensuring the optimal LNG production and inventory level at the liquefaction terminal in each time period. The shipping plan includes not only long-term contract but also short-term and spot. All operating vessels must initiate a tour from a liquefaction terminal at the depot and complete the tour after unloading cargoes visiting regasification terminals at remote demand locations by designated sea routes.

All LNG carriers have its own specific tank capacity, loading conditions and average vessel speed must observe. The tank capacity is from 140,000 billion cubic meters (bcm) up to 216,000 bcm. The fleet of heterogeneous vessels can be divided into two

groups depending on loading conditions: Type I (no partial tank filling) and Type II (partial tank filling is allowed). Type I vessels are prohibited from partial loading, which means that the amount of LNG in a tank must be over any specific level or empty tank to avoid sloshing impact. This type of vessels can only serve individual customers unless the additional short-term or spot demand is very small. Type II vessels have no restriction on partial tank filling so that multiple customers can be served by an assigned LNG vessel within the given tank capacity. We formulate this problem as LNG VRP model in mixed integer programming considering the rate of BOG. In addition, we give a small buffer on the time window by allowing few days of plus and minus from the target delivery date to ensure a flexibility of transportation.

### 3. MATHEMATICAL FORMULATIONS

#### 3.1 Deterministic model

The deterministic LNG VRP model is presented in this section and the indices and sets, data and decision variables are the following:

##### Indices and Sets:

S	Set of LNG terminals;
T	Set of time periods;
K	Set of LNG tankers;
$s \in S$	Index of LNG terminal;
$t \in T$	Index of time period;
$k \in K$	Index of LNG tanker;
$G(V,A)$	Directed graph nodes $V=\{1,2,\dots, S =s+max(s)(t-1)\}$ as the set of terminals and $A=\{(i,j):i,j \in V,i \neq j\}$ as the set of arcs in the planning time horizon;
$h \in H$	Index of the origin (depot), where $h=1+ S (t-1)=max(s)(t-1)$ in the planning time horizon, $H \subseteq V$ ;
$r \in R$	Index of Type I LNG tanker, $R \subseteq K$ .

##### Data:

$DAY_{ij}$	Estimated travel time from $i$ to $j$ ;
$DSC_k$	Daily shipping cost of vessel type $k$ ;
$D_{j,t}$	Demand at $j$ in time period $t$ ;
REV	Unit revenue of LNG per billion cubic meters (bcm) ;
$CYC_j$	Expected target delivery date at $j$ ;
$VC_k$	Cargo capacity of vessel $k$ ;
$VN_k$	Total number of vessel $k$ ;
$STCOST_t$	Unit storage cost in time period $t$ ;
$PDCOST_t$	Unit production cost in time period $t$ ;
TM	Maximum number of terminals can be visited in a route;
M	Big-M;
$\alpha$	Cargo filling limit ratio (%) of Type I LNG tankers;
$\beta$	Time window - number of acceptable days from target delivery date;
$\epsilon$	Boil-off rate (BOR) (%) [ $\epsilon, \bar{\epsilon}$ ];

$\delta$  Storage level at liquefaction terminal [ $\delta, \bar{\delta}$ ].

##### Decision variables:

$y_{ij}$	Amount of LNG delivering from $i$ to $j$ ;
$x^1_{ij,k}$	= 1 if vessel $k$ operates from terminal $i$ to terminal $j$ 0 otherwise
$x_t^2$	Production level in time period $t$ ;
$x_t^3$	Inventory level in time period $t$ ;
$x_i^4$	Vessel arrival time (date) at $i$ , and $x_i^4 = 0$ ;
$x_i^5$	Accumulated travel time (days) from initial supply terminal to $j$ , and set departure time at the depot as $x_i^5 = 0$ ;
$u_i$	Flow in the vessel after it visits $i$ .

Then, LNG VRP formulation is as follows.

#### 3.1.1 Objective function

Maximize

$x \in X, y \in Y$

$$\sum_{(i,j) \in A} REV \cdot (1 - \epsilon DAY_{ij}) y_{ij} \quad (1a)$$

$$-\sum_{t \in T} (PC_t x_t^2) \quad (1b)$$

$$-\sum_{t \in T} SC_t x_t^3 \quad (1c)$$

$$-\sum_{(i,j) \in A} \sum_{k \in K} (DAY_{ij} DSC_k x^1_{ij,k}) \quad (1d)$$

The objective function maximizes the overall revenue considering all potential cost factors in the supply chain.

The first term of the objective maximizes profit by subtracting the cost of evaporated gas in accordance with BOR, duration of shipping and the amount of LNG in a cargo tank (1a). The second (1b) and third term (1c) minimize production and storage cost. These values are dependent not only on the production level and storage level but also on the amount of BOG and ship routes decisions indirectly from the term (1a). The term (1d) of the objective is to minimize overall vessel operating cost based on daily shipping cost of each vessels and ship duration from a previous terminal to next destination.

### 3.1.2 Constraints

The LNG VRP model considers multiple time periods in a model. However, it is formulated as single time period model by re-indexing the terminal index with time period index. So, index of terminals implies about what terminal may be served in which time period. Therefore, constraints (2) and (3) nullify the repeating indices of liquefaction terminals in the model.

$$\sum_{k \in K} x^1_{s, s+|S|(t-1), k} = 0, \quad \forall s \in S, t \in T \setminus \{1\}, \quad (2)$$

$$\sum_{k \in K} x^1_{s+|S|(t-1), s, k} = 0, \quad \forall s \in S, t \in T \setminus \{1\}, \quad (3)$$

When a route decision is made, a vessel assignment also has to be determined simultaneously. Once a vessel is assigned, the vessel must complete the tour without being replaced by other vessels returning to the liquefaction terminal. Constraints (4) control this condition checking vessel flows from previous tour decision and the next tour decision.

$$x^1_{i, j, k} \leq \sum_{l \in V} x^1_{j, l, k} \leq N - (N - 1) x^1_{i, j, k}, \quad \forall (i, j) \in A, k \in K, \quad (4)$$

When a ship is assigned to a route, the amount of laden LNG cargo must be less than the tank capacity of a vessel (5), while the number of operating vessels also must be less than the number of vessels in a fleet (6).

$$y_{i, j} \leq \sum_{k \in K} VC_k x^1_{i, j, k}, \quad \forall (i, j) \in A, \quad (5)$$

$$\sum_{j \in V} \sum_{h \in V} x^1_{h, j, k} \leq VN_k, \quad \forall k \in K, \quad (6)$$

Constraints (7) ensure that all departed vessels must return to the original liquefaction terminal after completing yours. Constraints (8) and (9) establish the condition that a customer can receive a shipment by one designated vessel in each time period.

$$\sum_{j \in V} \sum_{k \in K} x^1_{h, j, k} = \sum_{i \in V} \sum_{k \in K} x^1_{i, j, k}, \quad \forall h \in H, \quad (7)$$

$$\sum_{j \in V} \sum_{k \in K} x^1_{i, j, k} = 1, \quad \forall i \in V \setminus \{1\}, \quad (8)$$

$$\sum_{i \in V} \sum_{k \in K} x^1_{i, j, k} = 1, \quad \forall j \in V \setminus \{1\}, \quad (9)$$

As stated above, all departed vessels from the depot must return to the origin, and should not terminate the tour while making any sub-tours. For each routing decision, Miller-Tucker-Zemlin (MTZ) sub-tour elimination constraints filter any possible sub-tours in constraints (10) (Miller et al., 1960).

$$u_i - u_j + TM \sum_{k \in K} x^1_{i, j, k} \leq TM - 1, \quad \forall (i, j) \in A, \quad (10)$$

Constraints (11) denote the relation between the amount of LNG loading to a cargo tank and the demands in each time period. Particularly, as evaporated gas losses are expected during transportation, an additional amount of LNG is considered in the constraints.

$$\sum_{i \in V} (1 - \epsilon_{DAY}) Y_{i, j} - \sum_{t \in T} D_{j, t} = \sum_{l \in V} y_{j, l}, \quad \forall j \in V \setminus \{1\}, \quad (11)$$

Once a laden LNG vessel unloads all cargoes at regasification terminals, the returning vessel must be empty in practice excluding the minimum amount of LNG cargo for cooling purposes. So, constraints (12) set the cargo level of laden LNG vessel returning to a liquefaction terminal as '0'.

$$\sum_{i \in V} Y_{i, h} = 0, \quad \forall h \in H, \quad (12)$$

Based on LNG contract terms, a specific amount of LNG cargoes have to be delivered to customers at the expected time on regasification terminals allowing a few days grace period from the expected time. Constraints (13) and (14) accumulate the sailing time of an operating vessel and constraints (15) set the time window from an expected delivery date on a target customer.

$$x_j^5 \geq x_i^5 + \text{DAY}_{ij} - M(1 - x_{ij,k}^1), \quad \forall (i,j) \in A, k \in K, \quad (13)$$

$$x_j^4 \geq x_i^5 + \text{DAY}_{ij} - M(1 - x_{i,1,k}^1), \quad \forall i \in \{1\}, k \in K, \quad (14)$$

$$|x_j^5 - \text{CYC}_j| \leq 0.5 \beta, \quad \forall j \in A, \quad (15)$$

As type I LNG vessels have strict filling limits on cargo tanks during voyages, constraints (16) set this condition based on the allowed filling limit ratio ( $\alpha$ ).

$$y_{ij} \geq \alpha \text{VC}_r x_{ij,r}^1, \quad \forall (i,j) \in A, r \subseteq K, \quad (16)$$

Planning inventories and production levels are determined by the demand level in each time period in constraint (17). Safety stock and maximum storage level at the depot is set up in constraints (18).

$$x_t^2 - x_t^3 + x_{t-1}^3 = \sum_{j \in V} D_{t,j}, \quad \forall t \in T, \quad (17)$$

$$\underline{\delta} \leq x_t^3 \leq \bar{\delta}, \quad \forall t \in T, \quad (18)$$

### 3.2 A stochastic extension of BOG impact to the LNG VRP

We reformulated the proposed deterministic model into a two-stage stochastic model considering BOG uncertainty. The random elements are the following:

#### Random elements:

- $\Omega$  Set of scenarios;
- $\omega \in \Omega$  Index of scenario;
- $p_\omega \in P$  The probability mass function in accordance with scenario  $\omega$ .

The stochastic model can be written as (Birge and Louveaux, 2011):

$$\begin{aligned} \min_{x \in X} \quad & c^T x + q(x) \\ \text{s.t.} \quad & Ax = b \end{aligned} \quad (19)$$

and the recourse function  $q(x)$  can be written as (20) as we consider discrete probability distribution  $P$ :

$$q(x) = \mathbb{E}_\omega Q(x, \omega) = \sum_{(i,j) \in A} \sum_{\omega \in \Omega} p_\omega Q(x, \omega) \quad (20)$$

where

$$q(x, \omega) = \min_{y \in Y} d_\omega^T y \quad (21)$$

$$T_\omega x + W_\omega y = h_\omega$$

We denote  $\mathbb{E}_\omega$  as a mathematical expectation, and  $\omega$  as a scenario with respect to probability space  $(\Omega, P)$ . In the two-stage LNG routing problem,  $Q(x, \omega)$  is the optimal value of BOG (second stage problem). First-stage decisions are expressed in vector  $x$  and second-stage decisions are actions represented by  $y$ . Accordingly, the objective function of deterministic model can be reformulated into a stochastic form in (22). Constraints (23) are replacing constraints (11) as well.

$$\sum_{(i,j) \in A} \sum_{\omega \in \Omega} \text{REV} \cdot p_\omega (1 - \varepsilon_\omega \text{DAY}_{ij}) y_{ij, \omega} - \sum_{t \in T} (\text{PC}_t x_t^2 + \text{SC}_t x_t^3) \quad (22)$$

$$-\sum_{(i,j) \in A} \sum_{k \in K} (\text{DAY}_{ij} \text{DSC}_k x_{ij,k}^1) - \sum_{i \in V} x_i^4,$$

$$\sum_{i \in V} (1 - \varepsilon_{\omega} \text{DAY}_{ij}) y_{ij,\omega} - \sum_{t \in T} d_{j,t} \quad \forall j \in V \setminus \{1\}, \omega. \quad (23)$$

$$= \sum_{i \in V} y_{j,i,\omega}$$

### 3.3 Monte Carlo sampling

The stochastic version of LNG VRP model has an infinite number of BOG scenarios. In this research, however, we use the Monte Carlo sampling-based optimization that may reduce the computational burden while generating decent solutions in a reasonable time with a limited number of scenarios.

Let  $\omega_1, \dots, \omega_n$  be random generated sample drawn from  $P$ . Following the law of large numbers, for a given vector  $x$ , we have

$$n^{-1} \sum_{n \in N} Q(x, \omega_n) \quad \text{with probability one.} \quad (24)$$

$$\rightarrow \mathbb{E}_{\omega} Q(x, \omega)$$

Therefore  $Q(x) = \mathbb{E}_{\omega} Q(x, \omega)$  is represented by the sample mean  $\hat{Q}_n(x) = n^{-1} \sum_{n \in N} Q(x, \omega_n)$  and the constraints (22) can be rewritten as constraints (25).

$$\frac{1}{n} \sum_{(i,j) \in A} \sum_{\omega_n \in \Omega} \text{REV} \cdot (1 - \varepsilon_{\omega_n} \text{DAY}_{ij}) y_{ij,\omega_n} - \sum_{t \in T} (PC_t x_t^2 + SC_t x_t^3) \quad (25)$$

$$- \sum_{(i,j) \in A} \sum_{k \in K} (\text{DAY}_{ij} \text{DSC}_k x_{i,j,k}^1) - \sum_{i \in V} x_i^4$$

## 4. COMPUTATIONAL STUDY

The computational study presented in this chapter evaluates the deterministic LNG VRP model and two-stage stochastic model under BOG uncertainty by comparing each solution. In section 4.1 the numerical example is described along with the experimental settings to solve the models. In section 4.2 optimal routing solutions are depicted on a diagram with analysis on scheduling decisions. And then, the solution differences between deterministic and stochastic model is compared by means of Expected Value of Perfect Information (EVPI) and Value of Stochastic Solution (VSS). Further sensitivity analysis is done to investigate how the ratio between Type I and II vessels in a fleet influence to optimal solutions and what are implied meanings of the composition of vessels.

### 4.1 Test case description and settings

The LNG VRP has been solved by GAMS/CPLEX (Brooke, 2010). We set relative termination tolerance as 3 % (optcr = 0.03) and time limits as 10 hours (reslim = 36000) in GAMS/CPLEX model. All following experimental outcomes were optimized on a 3.00 GHz Intel Xeon machine with 400 GB of memory, running CPLEX version 12.6.

We tested the incidence of Qatar, the biggest LNG exporter with 5 contracted importers over the world planning a biannual shipping schedule. For the delivery, supplier owns total 18 LNG vessels including 12 Type I vessels and 6 Type II vessels (See Appendices A). The average sailing speed is 19.5 nautical miles per hour (kn). All sea routes are determined and the distances between terminals are given as constants (See Appendices B). Each demand is classified as long-term, short-term or spot with expected target delivery dates with  $\pm 4$  days as time window (See Appendices C). Overall planning horizon is from D+0 to D+192 days. Daily BOG in a tank ranges 0.1 % ~ 0.15 % follows a normal distribution,  $N(0.00125, 0.000104567^2)$ . Inventory level is in between 5,000 bcm and 10,000 bcm at the depot (See Appendices D). To solve the stochastic model, we repeated 10 times of Monte Carlo optimization.

### 4.2 Numerical results

Figure 1 shows the optimized 6 month routing plan from D+1 to D+192 observing target delivery dates with times windows per each time period. In the schedule, 11 routes are generated and 9 LNG carriers are assigned to the routes. Among the assigned vessels, there are 4 Type II vessels serving two demand cargoes in a route, and another 7 Type I vessels deliver cargoes to single customer in a tour.

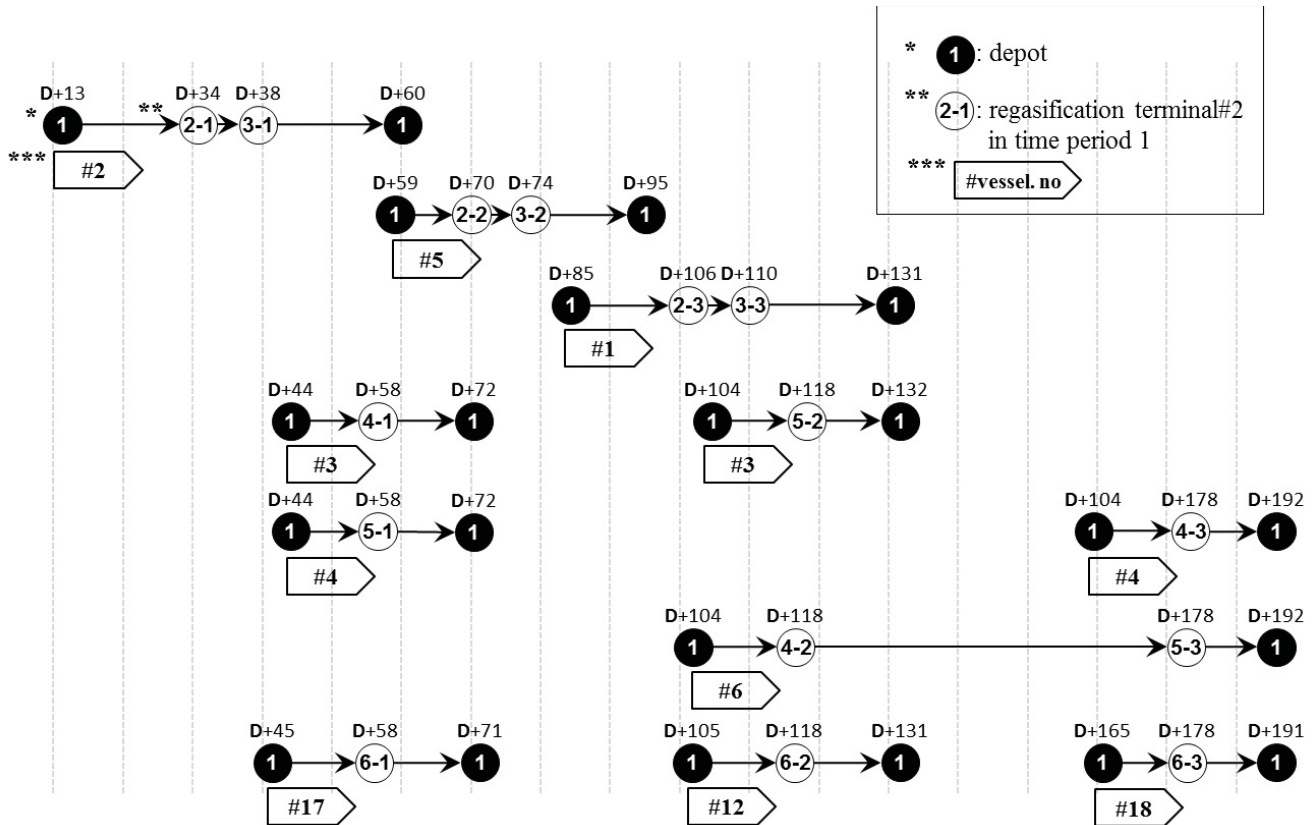

Figure 1. LNG ship routing plan from D+1 to D+192.

The measures to evaluate stochastic solutions are EVPI and VSS. EVPI is the difference between Wait and See (WS) and stochastic solution (RP) which expresses the value of information. WS is defined as a probability-weighted average of deterministic solution assuming any specific scenario realization. In this experiment, we can calculate  $EVPI = WS - RP = 1,096,784,497 -$

$1,096,737,898 = 46,599$ . On the other hand, VSS is RP minus EEV in this maximization problem which is the expected result of using mean value problem. In this test problem,  $EEV = 1,096,737,898$  and so we can know the value  $VSS = RP - EEV = 12,557$  verifying the general relations between the defined measures;  $EEV \leq RP \leq WS$  in Figure 2: (Birge and Louveaux, 2011).

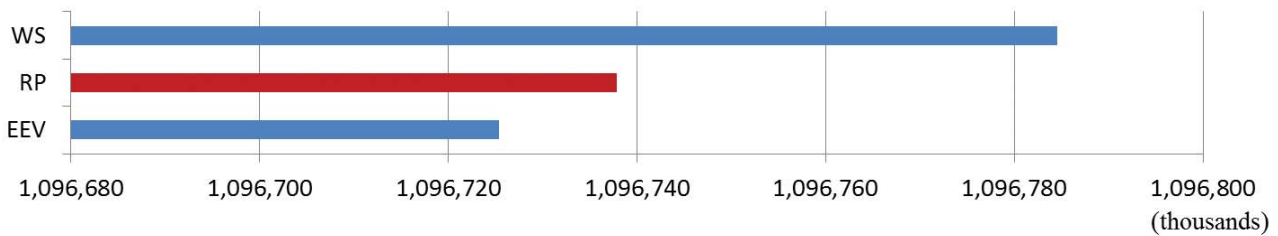
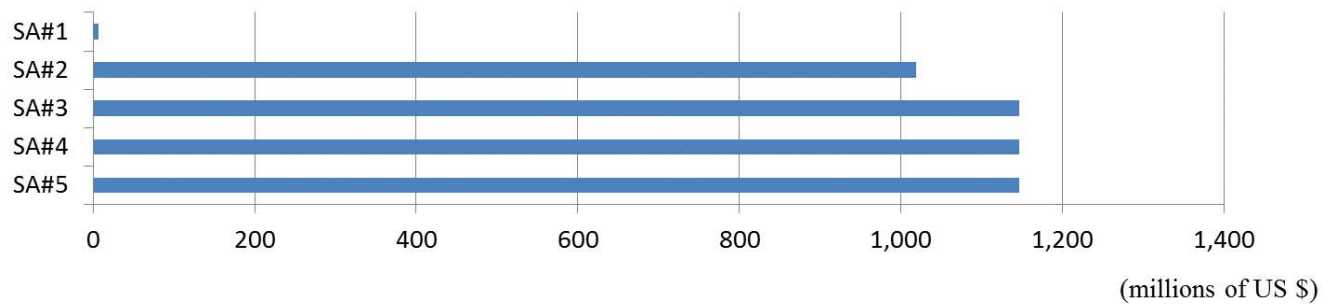

Figure 2. Optimal solutions of WS, RP and EEV.



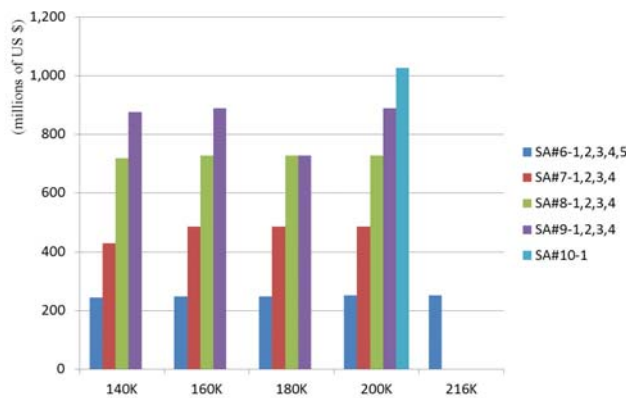

**Figure 3.**  
Sensitivity analysis: SA#1-5.

We conducted sensitivity analysis (SA) by varying the number of vessels between Type I and II vessels in a fleet:

(1) SA #1-#5: SA#1 is the instance that all vessels are in Type I. SA#5 is the case that all vessels are in Type II. In SA#2, 3&4, it examined the sensitivity of adding numbers of Type II vessels. As a result in Figure 3, we observed that there are significant gap between SA#1 and SA#2. This means that removing restrictions on cargo partial filling allows serving multiple customers if transportation is cost beneficial. In SA#3 and 5, there is no change because additional vessels are not necessary to maximize the profit. So, in term of long-term vessel procurement, decisions to acquire additional vessels may be critical to avoid unnecessary costs.

(2) SA #6-#10: It analyzes the impact of increasing number of vessels per each vessel type from 140,000 bcm to 216,000 bcm. Figure 4 shows that increasing profit is roughly proportional to the number of Type II vessels. Hence, it is recommended to replace the current Type I vessels to Type II.



**Figure 4.**  
Sensitivity analysis #6-#10.

## 5. CONCLUSIONS

In this paper, we proposed a deterministic LNG VRP model and formulated the problem using the notion of multiple vehicle routing problem. Based on this model, further extension of two-stage stochastic model was also presented applying Monte Carlo optimization techniques.

Traditional LNG ship routing and scheduling problem only aims to satisfy long-term contract. However, as short-term and spot demand are rapidly increasing in LNG market, and also as LNG vessel technology can relax strict restrictions on filling limits of cargo tanks, we exactly reflected these changing environmental factors into our model. The LNG VRP model can generate six months of shipping and inventory and production schedule to serve multiple customers in a route assigning an appropriate LNG vessel.

In the computational study, we showed the effectiveness of our model optimizing ship routes and schedules within the planning time horizon. As we compare the deterministic LNG VRP and its stochastic version by the measures of EVPI and VSS, we clarified the stability of stochastic solutions comparing to deterministic one. As verified in the sensitivity analysis, replacing Type I to Type II vessels in a fleet may increase more expected profit. However, it must be considered to identify how many Type II vessels are required to maximize overall profit.

As stated in the model, BOR is affected by various uncertain interactive factors, and so it needs further research to develop a mathematical model to measure accurate BOR. Even though we consider many elements as deterministic components, there are still many inherent uncertainties causing severe disruptions in LNG supply chain such as hurricane, dust storm, Tsunami, political unrest and piracy may significantly disturb planned shipping or degrade overall capability of LNG supply chain and so, we expect that this will be additional research interests in the future.



## APPENDICES

**Table 1.**

Specification of LNG tankers.

No.	Tank capacity (unit: bcm)	Daily shipping cost (unit: US dollars)	Vessel type
#01	140,000	200,000	II
#02	140,000	195,000	II
#03	140,000	190,000	II
#04	140,000	185,000	II
#05	160,000	195,000	II
#06	160,000	190,000	II
#07	160,000	185,000	I
#08	160,000	180,000	I
#09	180,000	195,000	I
#10	180,000	190,000	I
#11	180,000	185,000	I
#12	180,000	180,000	I
#13	200,000	195,000	I
#14	200,000	190,000	I
#15	200,000	185,000	I
#16	200,000	180,000	I
#17	200,000	175,000	I
#18	216,000	180,000	I

**Table 2.**

Distance between terminals.

	(unit: kn)				
	Ter.#1	Ter.#2	Ter.#3	Ter.#4	Ter.#5
Depot	9,882	9,770	6,576	6,350	6,233
Ter.#1		533	9,191	5,073	9,940
Ter.#2			9,208	4,891	9,957
Ter.#3				11,513	954
Ter.#4					11,141

**Table 3.**

Customers demand in each time periods.

Time periods	No.	Demand (bcm)	Target date (from D+0 days)	Contract type
#1	#02	60,000	D+36	spot demand
	#03	62,500	D+36	short-term
	#04	65,000	D+60	long-term
	#05	175,000	D+60	long-term
	#06	60,000	D+60	long-term
#2	#08	60,000	D+72	spot demand
	#09	62,500	D+72	short-term
	#10	65,000	D+72	long-term
	#11	175,000	D+120	long-term
	#12	60,000	D+120	long-term
#3	#14	60,000	D+108	spot demand
	#15	62,500	D+108	short-term
	#16	65,000	D+180	long-term
	#17	175,000	D+180	long-term
	#18	60,000	D+180	long-term

**Table 4.**

Other parameters.

Item	Data	Unit
Unit Price	105	US dollars / bcm
Storage operating cost	105	US dollars / bcm
Production cost	105	US dollars / bcm
Maximum storage level	10,000	bcm
Minimum storage level	5000	bcm
BOG level	[0.001, 0.0015]	percent
Filling limit of vessels type #07- #18	0.9	percent
Vessel speed	19.5	kn
Time window (from a target date)	±4	days

**Table 5.**  
Sensitivity analysis instances.

SA	Objective value	No. of Type II vessels				
		140K [0,4]	160K [0,4]	180K [0,4]	200K [0,5]	216K [0,1]
#1	7,137,500	0	0	0	0	0
#2	1,018,532,546	1	1	1	1	1
#3	1,146,492,567	2	2	2	2	1
#4	1,146,492,567	3	3	3	4	1
#5	1,146,492,567	4	4	4	5	1
#6-1	244,638,911	1	0	0	0	0
#6-2	248,293,911	0	1	0	0	0
#6-3	248,293,911	0	0	1	0	0
#6-4	252,543,911	0	0	0	1	0
#6-5	252,458,911	0	0	0	0	1
#7-1	430,355,322	2	0	0	0	0
#7-2	487,665,322	0	2	0	0	0
#7-3	487,495,322	0	0	2	0	0
#7-4	487,495,322	0	0	0	2	0
#8-1	718,026,733	3	0	0	0	0
#8-2	726,951,733	0	3	0	0	0
#8-3	726,781,733	0	0	3	0	0
#8-4	726,781,733	0	0	0	3	0
#9-1	875,478,702	4	0	0	0	0
#9-2	888,143,702	0	4	0	0	0
#9-3	726,781,733	0	0	4	0	0
#9-4	887,973702	0	0	0	4	0
#10-1	1,026,012546	0	0	0	5	0

**REFERENCES**

Andersson, H., Christiansen, M. and Fagerholt, K., (2010), Transportation planning and inventory management in the LNG supply chain, in: Energy, natural resources and environmental economics, pp. 427-439, Springer Berlin Heidelberg, [http://dx.doi.org/10.1007/978-3-642-12067-1\\_24](http://dx.doi.org/10.1007/978-3-642-12067-1_24)

U.S. Energy Information Administration, (2014), Annual Energy Outlook 2014 with projections to 2040, U.S. Department of Energy, available at: [http://www.eia.gov/forecasts/aeo/pdf/0383\(2014\).pdf](http://www.eia.gov/forecasts/aeo/pdf/0383(2014).pdf), [accessed 15 July 2014].

Birge, J. R. and Louveaux, a. F., (2011), Introduction to stochastic programming, Springer, <http://dx.doi.org/10.1007/978-1-4614-0237-4>

Bopp, A. E., Kannan, V. R., Palocsay, S. W. and Stevens, S. P., (1996), An optimization model for planning natural gas purchases, transportation, storage and deliverability.

Omega, 24(5), pp. 511-522, [http://dx.doi.org/10.1016/0305-0483\(96\)00025-4](http://dx.doi.org/10.1016/0305-0483(96)00025-4)

Brooke, A. K., (2010), GAMS/CPLEX 12. User notes. GAMS Development Corporation.

Chatterjee, N. and Geist, J. M., (1972), Effects of stratification on boil-off rates in LNG tanks. Pipeline and Gas Journal, 199(11), pp. 40-45.

Christiansen, M., Fagerholt, K., Hasle, G., Minsaas, A. and Nygreen, B., (2009), An ocean of opportunities. OR/MS Today, pp. 24-31.

Christiansen, M., Fagerholt, K., Nygreen, B. and Ronen, D., (2013), Ship routing and scheduling in the new millennium, European Journal of Operations Research, 228(3), pp. 467-483., <http://dx.doi.org/10.1016/j.ejor.2012.12.002>

- Coelho, L. C. and Laporte, G., (2013), The exact solution of several classes of inventory-routing problems, *Computers & Operations Research*, 40(2), pp. 558-565., <http://dx.doi.org/10.1016/j.cor.2012.08.012>
- Dobrota, Đ., Lalić, B. and Komar, (2013), Problem of Boil-off in LNG Supply Chain, *Transactions on Maritime Science*, 2(02), pp. 91-100., <http://dx.doi.org/10.7225/toms.v02.n02.001>
- Grønhaug, R. and Christiansen, M., (2009), *Supply chain optimization for the liquefied natural gas business*, Berlin Heidelberg: Springer, [http://dx.doi.org/10.1007/978-3-540-92944-4\\_10](http://dx.doi.org/10.1007/978-3-540-92944-4_10)
- Grønhaug, R., Christiansen, M., Desaulniers, G. and Desrosiers, J., (2010), A branch and price method for a liquefied natural gas inventory routing problem, *Transportation Science*, 44(3), pp. 400-415., <http://dx.doi.org/10.1287/trsc.1100.0317>
- Halvorsen-Weare, E. E. and Fagerholt, K., (2013), Routing and scheduling in a liquefied natural gas shipping problem with inventory and berth constraints, *Annals of Operations Research*, 203(1), pp. 167-186, <http://dx.doi.org/10.1007/s10479-010-0794-y>
- Halvorsen-Weare, E. E., Fagerholt, K. and Rönnqvist, M., (2013), Vessel routing and scheduling under uncertainty in the liquefied natural gas business. *Computers & Industrial Engineering*, 64(1), pp. 290-301., <http://dx.doi.org/10.1016/j.cie.2012.10.011>
- Hartley, P. R., Mitchell, G., Mitchell, C. and Baker, J. A., (2013), *The Future of Long-Term LNG Contracts*, Crawley: University of Western Australia Business School.
- Huang, S. H. and Lin, P. C., (2010), A modified ant colony optimization algorithm for multi-item inventory routing problems with demand uncertainty, *Transportation Research Part E: Logistics and Transportation Review*, 46(5), pp. 598-611., <http://dx.doi.org/10.1016/j.tre.2010.01.006>
- US Department of Energy, (2005), *Liquefied Natural Gas: Understanding the basic facts*, US Department of Energy, available at: [http://energy.gov/sites/prod/files/2013/04/f0/LNG\\_primerupd.pdf](http://energy.gov/sites/prod/files/2013/04/f0/LNG_primerupd.pdf), [accessed 17 July 2014.].
- Miller, C. E., Tucker, A. W. and Zemlin, R. A., (1960), Integer programming formulation of traveling salesman problems, *Journal of the ACM (JACM)*, 7(4), pp. 326-329., <http://dx.doi.org/10.1145/321043.321046>
- Rakke, J. G., Stålhane, M., Moe, C. R., Christiansen, M., Andersson, H. F. and Norstad, I., (2011), A rolling horizon heuristic for creating a liquefied natural gas annual delivery program. *Transportation Research Part C: Emerging Technologies*, 19(5), pp. 896-911., <http://dx.doi.org/10.1016/j.trc.2010.09.006>
- Shin, Y., Kim, J. W., Lee, H. and Hwang, C., (2003), Sloshing impact of LNG cargoes in membrane containment systems in the partially filled condition, *13th International Offshore and Polar Engineering Conference*, Vol. 3, pp. 509-515.
- Stålhane, M., Rakke, J. G., Andersson, H., Christiansen, M. and Fagerholt, K., (2012), A construction and improvement heuristic for a liquefied natural gas inventory routing problem, *Computers & Industrial Engineering*, 62(1), pp. 245-255., <http://dx.doi.org/10.1016/j.cie.2011.09.011>
- Suvisaari, S., (2012), Delivering LNG in smaller volumes, *Wärtsilä Technical Journal*, 01, pp. 21-25.
- Tessier, J., (2001), Operating membrane LNG carriers-partial loading cases for 160,000 m<sup>3</sup> vessels and beyond, *The 13th International Conference & Exhibition on Liquefied Natural Gas*, Seoul, Korea, May 14-17, available at: <http://www.ivt.ntnu.no/ept/fag/tep4215/innhold/LNG%20Conferences/2001/Data/PAPERSVO/SESSION6/Ps6-6-te.pdf>, [accessed 4 June 2014.].
- Zakaria, M. S., Osman, K., Saadun, M. N., Manaf, M. Z., Hanafi, M. and Hafidzal, M., (2013), Computational Simulation of Boil-off Gas Formation inside Liquefied Natural Gas tank using Evaporation Model in ANSYS Fluent, *Applied Mechanics and Materials*, 393(2013), pp. 839-844., <http://dx.doi.org/10.4028/www.scientific.net/AMM.393.839>