

EFFECT OF Nb AND Ti ON MICROSTRUCTURE AND MECHANICAL PROPERTIES OF 30% Ni / 18% Cr CAST STEEL AFTER ANNEALING

Received - Primljeno: 2001-01-07

Accepted - Prihvaćeno: 2002-01-20

Original Scientific Paper - Izvorni znanstveni rad

The study discusses the microstructure and mechanical properties of eight tested 0.3 % C - 30 % Ni - 18 % Cr cast steels stabilized with niobium and titanium after annealing in the cycle of 900 °C / 300 h. The niobium content in the cast steels varied from 0.0 to 2.0 % and that of titanium from 0.0 to 1.2 % by weight. Microstructure was examined using both light microscope and a scanning electron microscope with Link IS-IS attachment as well as an X-ray diffractometer. Depending on the chemical composition of cast steel, the following phases were identified: carbides of MC and $M_{23}C_6$ type and a phase rich in silicon, nickel, niobium and / or titanium, which was supposed to be a phase G. Relationships between the microstructure and mechanical properties of cast steel at 20 and 900 °C were examined as well.

Key words: cast steel, microstructure, mechanical properties, annealing

Utjecaj Nb i Ti na mikrostrukturu i mehanička svojstva lijevanog čelika 30 % Ni / 18 % Cr nakon žarenja.

Studija raspravlja o mikrostrukturi i svojstvima osam testiranih lijevanih čelika - 0,3% C, 30 % Ni, 18 % Cr stabiliziranih niobijem i titanijem nakon žarenja u ciklusu od 900 °C / 300 h. Težinski udio niobija u lijevanim čelicima je varirao od 0,0 do 2,0 % a titanija od 0,0 do 1,2 %. Mikrostruktura se ispitala i svjetlosnim mikroskopom i skener-elektronskim mikroskopom s priključkom na link IS-IS kao i na rentgenski difraktometar. Ovisno o kemijskom sastavu lijevanog čelika, identificirane su slijedeće faze: karbidi tipa MC i $M_{23}C_6$ i faze bogate silicijem, niklom, niobijem i / ili titanijem, a koju se smatra da je faza G. Također se ispitivao i odnos između mikrostrukture i mehaničkih svojstava lijevanog čelika na temperaturi od 20 i 900 °C.

Ključne riječi: ljevani čelik, mikrostruktura, mehanička svojstva, žarenje

INTRODUCTION

Creep-resistant construction elements of furnaces for thermal and thermo-chemical treatment are in prevailing part made from austenitic nickel-chromium cast steel. One of the possible methods of increasing an operating life of these castings is by additions of Nb and/ or Ti introducing into their chemical composition. As a result of this, a better stability of the structure is achieved during operation [1].

This study is a fragment of more extensive research aiming at the development of a 0.3 %C - 30 % Ni - 18 % Cr cast steel with additions of Nb and Ti to be used for parts of furnace construction for the carburizing treatment. The results of structure examinations under the microscope were given along with the results of mechanical tests performed on cast steels with various content of Nb and/ or Ti, subjected before tests to a 900 °C / 300 h annealing cycle.

B. Piekarski, M. Garbiak, Institute of Materials Engineering, Technical University of Szczecin, Szczecin, Poland

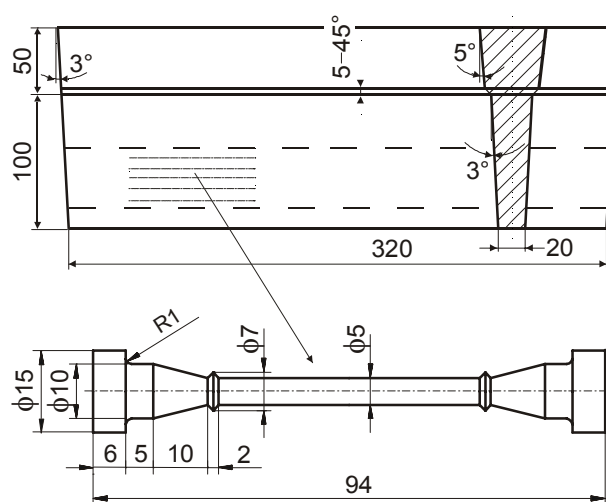

Figure 1. Shape and dimensions of the ingots and specimens for mechanical properties tests

Slika 1. Oblik i dimenzija ingota i uzoraka namijenjenih ispitivanjima mehaničkih svojstava

EXPERIMENTAL

Using an output of the research done previously [2], as a construction material for parts of the carburizing furnace, cast steel of the following composition (% by weight) was selected: 0.25 - 0.35 % C; 29-31 % Ni; 17-19 % Cr; 1.2 - 1.5 % Si. In continuation of this research, it was decided to check to what extent it may be advisable to add niobium and/or titanium as well as increase of silicon content in this cast steel. This research trend is consistent with the present state of art and forecasts regarding development of alloys of this type [3].

Following the plan of experiments, test melts were made [4], and after preliminary studies eight alloys were selected for further investigation. The alloys were melted in an open induction furnace with acid lining. Ingots were cast in sand moulds. The shape and dimensions of the ingots are shown in Figure 1.. The chemical composition of the cast steels is given in Table 1..

Table 1. **Chemical composition of experimental alloys, wt-%**
 Tablica 1. **Kemijski sastav slitina podvrgnutih eksperimentima, tež. %**

| Alloy | C | Si | Mn | P | S |
|-------|------|------|------|-------|-------|
| 1 | 0.29 | 1.91 | 0.97 | 0.013 | 0.009 |
| 2 | 0.34 | 1.61 | 0.97 | 0.017 | 0.012 |
| 3 | 0.36 | 2.07 | 0.94 | 0.013 | 0.010 |
| 4 | 0.31 | 2.21 | 0.95 | 0.018 | 0.012 |
| 5 | 0.30 | 1.34 | 0.91 | 0.015 | 0.009 |
| 6 | 0.31 | 2.41 | 0.96 | 0.015 | 0.010 |
| 7 | 0.39 | 2.48 | 0.94 | 0.019 | 0.010 |
| 8 | 0.30 | 1.62 | 0.92 | 0.017 | 0.009 |
| Alloy | Cr | Ni | Nb | Ti | |
| 1 | 17.9 | 29.2 | 0.03 | 0.03 | |
| 2 | 18.3 | 29.4 | 0.52 | 0.30 | |
| 3 | 18.3 | 29.2 | 0.10 | 0.70 | |
| 4 | 18.3 | 29.6 | 0.00 | 1.00 | |
| 5 | 18.3 | 29.5 | 1.67 | 0.05 | |
| 6 | 18.2 | 29.3 | 1.71 | 0.05 | |
| 7 | 18.2 | 29.2 | 1.66 | 0.68 | |
| 8 | 17.5 | 29.3 | 1.75 | 0.83 | |

The ingots were annealed at 900 °C for 300 hours. From these ingots specimens were next machined and used for the following examinations:

- observations under microscope of the polished sections and X-ray chemical analysis in microregions of the specimens performed on a Philips XL30 microscope equipped with a Link IS-IS X-ray dispersion spectrometer;
- identification of the precipitated phases, after their extraction from the matrix [5];

- mechanical testing at 20 and 900 °C. In static tensile test the following mechanical properties were determined: $R_{0.2}$ - 0.2 % yield strength, R_m - ultimate strength, and A_{10} - elongation ($l_0 = 10d$). The shape and dimensions of the specimens are shown in Figure 1. Since necking occurred in specimens at several places, the determination of reduction in area was not possible. The results of the measurements are compiled in Table 2..

Table 2. **Mechanical properties of examined alloys***
 Tablica 2. **Mehanička svojstva ispitivanih slitina**

| Alloy | $R_{0.2}$, MPa | R_m , MPa | A_{10} , % |
|----------------------------------|-----------------|---------------|--------------|
| Test temperature: 20 / 900 °C | | | |
| 1 | 253.5 / 78.9 | 490.4 / 118.7 | 6.70 / 24.5 |
| 2 | 243.5 / 77.1 | 442.7 / 117.2 | 6.40 / 19.0 |
| 3 | 242.6 / 72.6 | 428.3 / 111.0 | 5.90 / 24.3 |
| 4 | 236.4 / 68.7 | 400.0 / 101.2 | 6.40 / 30.4 |
| 5 | 239.1 / 80.5 | 447.8 / 120.3 | 8.00 / 20.7 |
| 6 | 231.9 / 74.8 | 429.2 / 119.1 | 8.00 / 31.3 |
| 7 | 225.1 / 62.6 | 429.1 / 104.8 | 8.30 / 33.4 |
| 8 | 186.3 / 57.9 | 427.0 / 98.7 | 7.30 / 22.9 |
| * Average from four measurements | | | |

RESULTS AND DISCUSSION

In as-cast condition the alloy structure is composed of an austenitic matrix and primary carbide precipitates present on the grain boundaries and in interdendritic spaces. A comparison of microstructures in these alloys leads to a

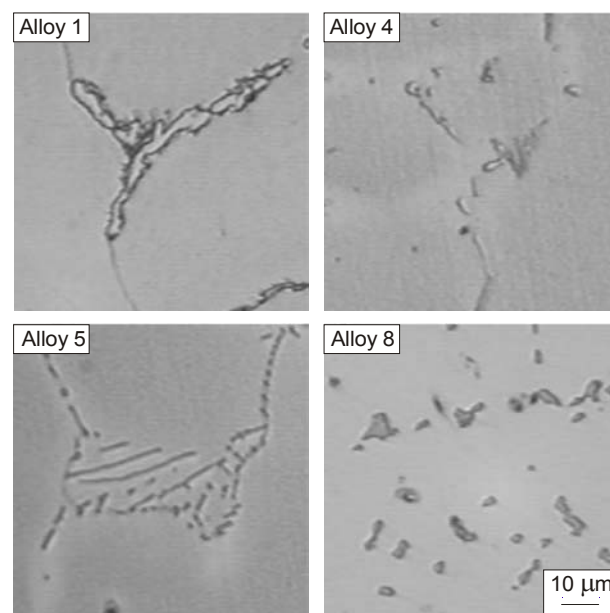

Figure 2. **Microstructure of examined alloys in as-cast condition**
 Slika 2. **Mikrostruktura ispitivanih slitina u lijevanom stanju**

conclusion that increasing, separately or jointly, the content of niobium and/or titanium in the cast steel has an important effect on the grain refinement and that it changes carbides morphology [6] - Figure 2.

As regards the chemical composition of these alloys, it can be expected that carbide eutectic may contain complex carbides, in this specific case these will be chromium carbides of the $M_{23}C_6$ type and simple MC carbides. Introducing titanium and niobium jointly into cast steel should result in the formation of isolated precipitates of the carbides of these elements, with each of the elements present in all the precipitates [7]. In cast steel no. 1, the heavy lamellar chromium carbides are observed to exist mainly on the ternary grain boundaries - Figure 2. In the remaining alloys in as-cast state, carbides of niobium and/or titanium of various shapes are prevailing. In cast steels nos. 4 and 5, where the additions of titanium and niobium have been introduced separately, the structure contains single TiC or NbC carbides, respectively, of two different shapes. In terms of quantity, the large lamellar carbides are prevailing; the remaining carbides are very fine and of globular shape. In interdendritic spaces the eutectic carbides jointly form a pattern, so typical of these alloys, called the Chinese script [8]. This is specially well visible in alloy no. 5 - Figure 2. In alloys nos. 2, 3, 7 and 8, containing both titanium and niobium, the morphology of eutectic carbides is quite different. Titanium carbides appear in the structure as fine polygon-shaped precipitates of random distribution. They are always surrounded by the precipitates of niobium carbides. Such location of titanium carbides proves that during the solidification process they have nucleated and grown definitely much earlier, acting as a leading phase for the fraction of niobium carbides. Irrespective of this, niobium carbides may also occur as independent precipitates, preserving their smooth and compact shape [6].

Figure 3. shows that annealing has provoked some important changes in alloy microstructure. First of all, in the first six cast steels, inside and around the austenite grain boundaries, large amounts of very fine secondary precipitates are present. It is very probable that these precipitates are chromium carbides of the $M_{23}C_6$ type [1]. Their content as well as the size decrease with increasing content of the stabilising elements in cast steel; fine precipitates inside the austenite grains are the first ones to disappear; large precipitates forming a continuous network along the austenite boundaries disappear later. In cast steels nos. 5, 6 and 7, only fine secondary precipitates are observed to enclose the primary eutectic carbides. The latter ones, due to ageing, have grown thicker, though still preserving their as-cast morphology. On the contrary, cast steel no. 8 is free from the fine, secondary precipitates of this type. Hence it can be concluded that carbon contained in the alloy was all bound into the primary carbides.

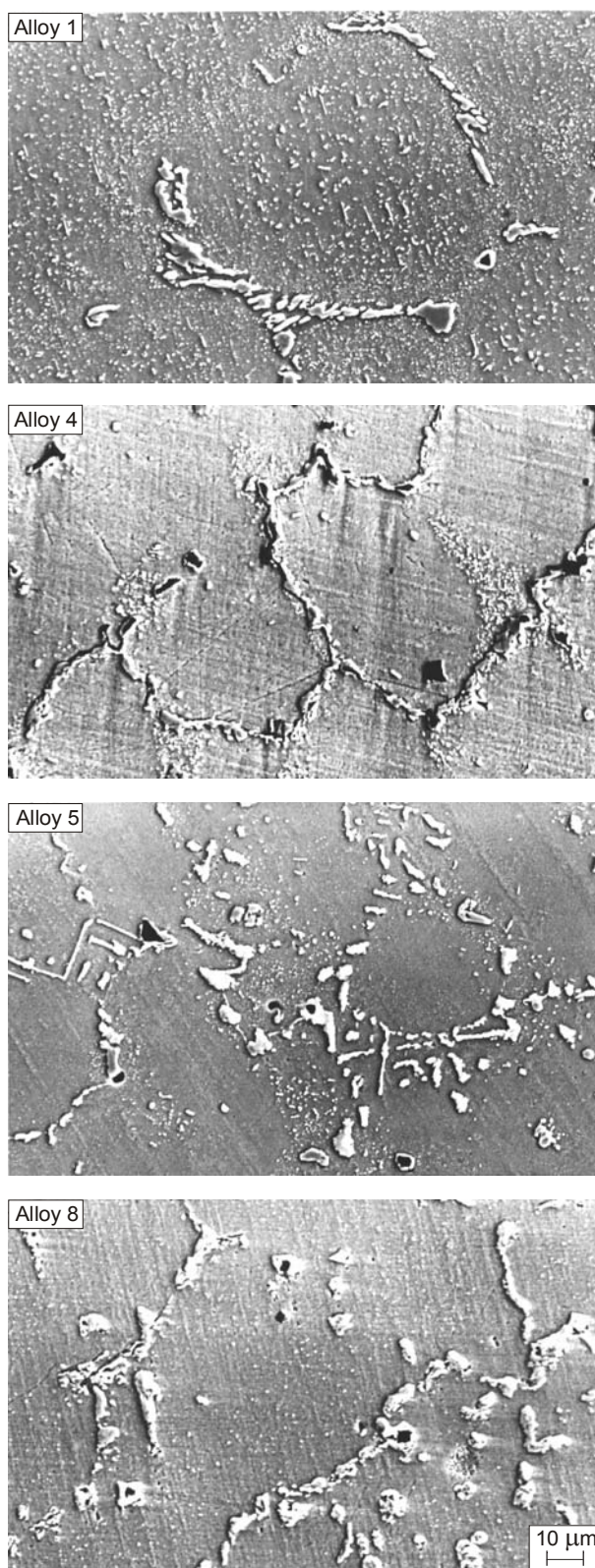
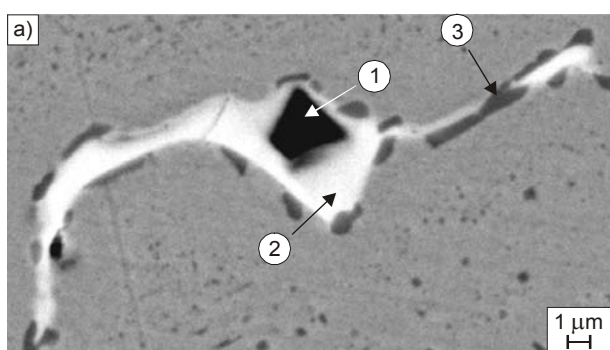

Figure 3. Microstructure of examined alloys after ageing 900 °C / 300h

Slika 3. Mikrostruktura ispitivanih slitina nakon otvrdnjavanja starenjem na 900 °C / 1300 h

The microstructures examined at higher magnifications also reveal the presence of other secondary precipitates, with the exception of alloys nos 1 and 2. Figures 4. and 5. show multi-phase complexes of precipitates observed in alloys nos. 2 and 8, followed by the results of microanalysis of their chemical composition. The image of microstructure on the grain boundaries in alloy no. 2 (Figure 4a) indicates the presence of at least three phases. The first phase - rich mainly in titanium (phase 1), the second - rich in niobium (phase 2), and the third one - rich in chromium (phase 3) - Figure 4.b. Their average chemical composition (Figure 4.b) enables the first two phases to be identified as carbides of MC type (TiC and NbC, respectively), while the third phase is supposed to be chromium carbide of the $M_{23}C_6$ type. An



b)

| | Si | Fe | Cr | Ni | Nb | Ti |
|--------|------|------|------|------|------|------|
| 1 | - | 0.6 | 1.0 | 0.3 | 12.7 | 85.4 |
| 2 | - | 0.9 | 1.0 | 0.4 | 76.1 | 21.6 |
| 3 | - | 14.6 | 80.5 | 4.9 | - | - |
| matrix | 2.10 | 49.1 | 17.3 | 31.5 | - | - |

Figure 4. Multiphase complex precipitates on the grain boundaries in the alloy 8: a) over view, b) results of quantitative microprobe analysis of precipitates and matrix, wt-%

Slika 4. Višefazni kompleks precipitata na granicama zrna u slitini 8: a) pregled, b) rezultati kvantitativne analize mikroprobe precipitata

isomorphous structure of the NbC and TiC carbides suggests that phase 1 can be identified as a titanium carbide with high content of niobium, while phase 2 can be niobium carbide with high content of titanium. The higher total content of the stabilizing elements allows the formation of not only MC type carbides, where both elements are characterized by strong solubility in each other, but also of the secondary binary carbides - alloy no. 8, Figure 5.a. Between the carbides (titanium in black colour and light niobium), a transition zone has been formed. At the same time, around a TiC-NbC complex a light colour envelope is visible. The linear distribution of elements shows that the envelope is rich, first of all, in silicon and nickel - Figure 5.b. The presence of the envelopes can prove the transformation of MC carbides which is supposed to take place during annealing.

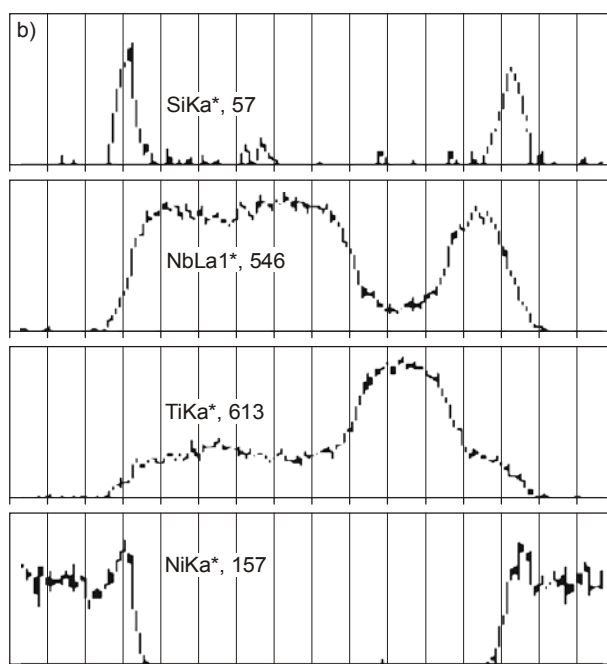
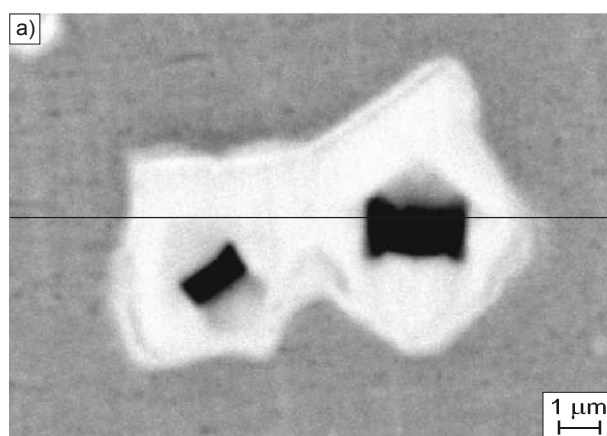

Figure 5. Multiphase complex precipitates on the grain boundaries in the alloy 8: a) over view, b) concentration profiles of alloying elements across the matrix and the precipitates

Slika 5. Višefazni kompleks precipitata na granicama zrna u slitini 8: a) pregled, b) koncentracija profila i elemenata slitine preko matrice i precipitata

To enlarge information on the phase composition of the examined alloys, they were separated by electrolytic extraction from the matrix and were subjected next to an X-ray structure examination. The results of the X-ray phase analysis of the isolates are compiled in Figure 6. taking as an example alloys nos. 2, 4, 5 and 8. On this drawing, the observations made previously have been documented:

- alloys nos. 2, 4 and 5 - the isolate contains carbides of MC type (in accordance with the chemical composition of alloy, these are the NbC and/or TiC carbides) and carbides of the $M_{23}C_6$ type;

- alloy no. 8 - on diffraction pattern three reflexes corresponding to three types of MC carbides are visible; the angular range Q is $40 - 42^\circ$. Two are characterized by low intensity (NbC and TiC), while the third one is located in between the former two, which can prove the formation of a solution of the secondary carbides. On the diffraction pattern it was designated by symbol (Nb, Ti)C. On the other hand, the reflexes of chromium carbide $M_{23}C_6$ are not found in this pattern. There are, however, reflexes characterized by very high intensity which

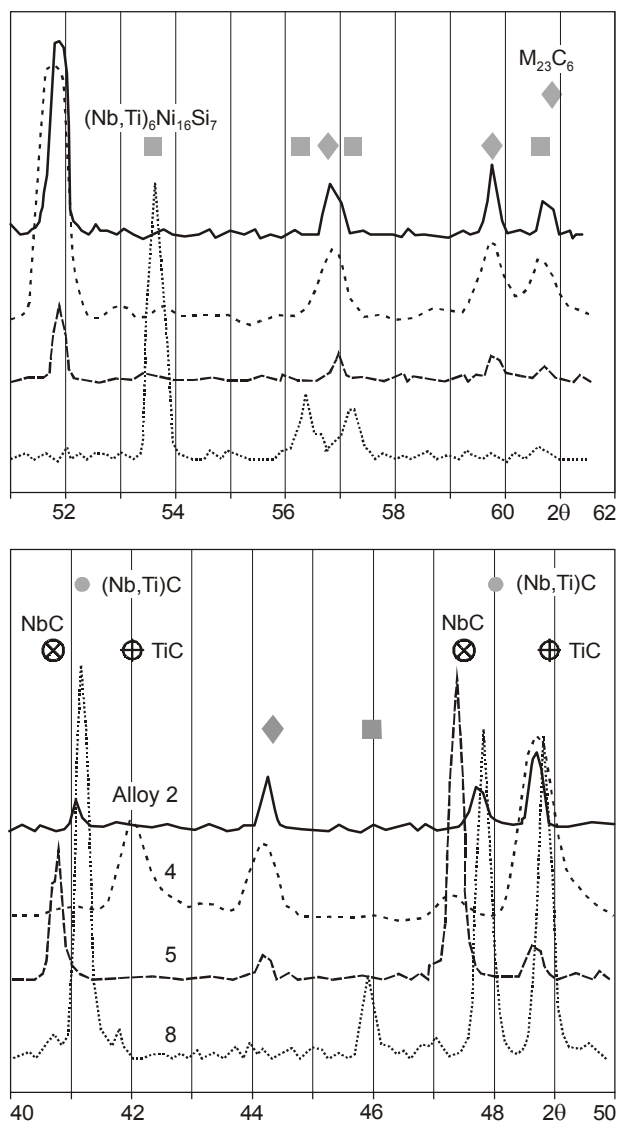

Figure 6. X-ray diffraction spectra from electrolytically extracted residues
Slika 6. Spektar ogiba rentgenskih zraka ostataka izdvojenih elektrolitičkim putem

have been assigned to the phase G and designated by symbol $(Nb, Ti)_6Ni_{16}Si_7$. Due to the presence of independent lines belonging only to this phase, characterized by high intensity, it was possible to measure its lattice con-

stant. The obtained value has been 11.23×10^{-10} m, which is consistent with the results quoted by [9].

On the other hand, the results shown in Figure 6. cannot be regarded as sufficient proof of the occurrence of phase G in the remaining alloys. The results of the chemical analyses carried out in microregions of the specimens testify that the phase rich in Ni and Si is present in all cast steels except alloys nos. 1 and 2. It is formed on the MC carbide-matrix interface - Figure 7.. The results of the present study are not sufficient to explain the mechanism of the phase G formation. In alloy no. 8 (Figure 5.) the transformation $MC \rightarrow G$ may proceed in situ, while in alloys nos. 4 and 5 the fine precipitates of chromium carbides, present near the phase G, can play some role in this transformation - Figure 7..

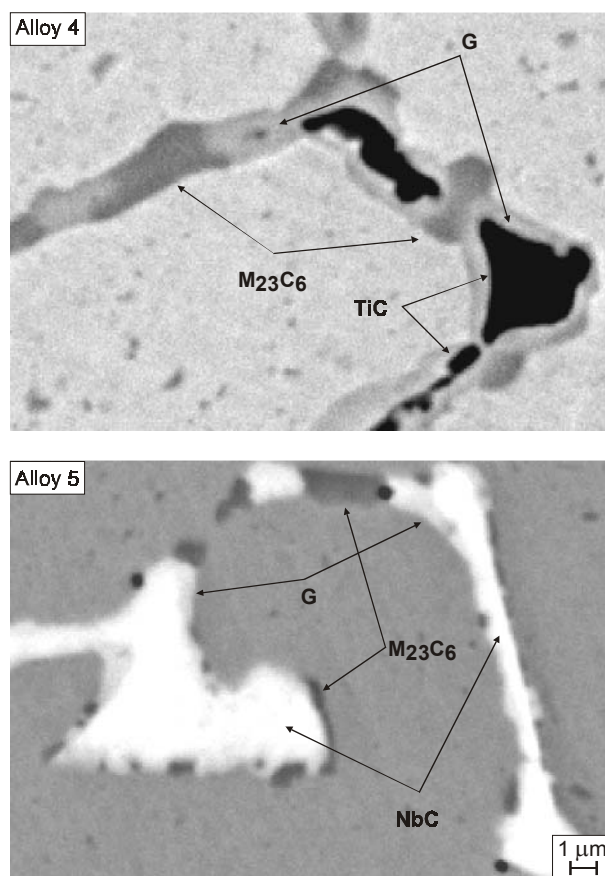

Figure 7. Examples of the formation of G phase on the grain boundary
Slika 7. Primjeri stvaranja faze G na granici površine zrna

Using the method of regression of the second order, the equations describing the relationships between the results of the measurements compiled in Table 2 and the chemical composition of cast steel [6] were derived. The variables x_i (C, Si, Mn, Nb and Ti) were reduced to a standard form within the range of 0.5-1.5 according to the relationship:

$$x_i = (x - x_{min}) / (x_{max} - x_{min}) + 0.5 \quad (1)$$

At the same time, the following parameters were computed: R -correlation coefficient, S -unbiased variance estimator, F -Snedecor's test value. Below the derived equations are given along with the indexes of statistical estimation:

$$\begin{aligned} R_{0.2} &= 257.1 + 10.9x_C^2 - 36.1x_{Nb}x_{Ti}, \\ R &= 0.98, S = 5.5, F = 57.4 \end{aligned} \quad (2)$$

$$\begin{aligned} R_{0.2}^{900} &= 76.5 - 10.9x_{Nb}x_{Ti} + 3.1x_{Mn}^{-1}x_{Ti}^{-1}, \\ R &= 0.98, S = 1.9, F = 74.4 \end{aligned} \quad (3)$$

$$\begin{aligned} R_m &= 430.9 - 23.2x_{Mn}x_{Ti} + 17.3x_{Nb}^{-1}x_{Ti}^{-1}, \\ R &= 0.95, S = 10.6, F = 24.2 \end{aligned} \quad (4)$$

$$\begin{aligned} R_M^{900} &= 125 - 5.2x_{Nb}x_{Ti} - 8.7x_{Ti}^2, \\ R &= 0.99, S = 1.9, F = 89.9 \end{aligned} \quad (5)$$

$$\begin{aligned} A_{10} &= 6.07 + 0.83x_{Nb}^2, \\ R &= 0.90, S = 0.47, F = 25.0 \end{aligned} \quad (6)$$

$$\begin{aligned} A_{10}^{900} &= 17.7 + 6.8x_{Si}^2, \\ R &= 0.95, S = 1.91, F = 57.7 \end{aligned} \quad (7)$$

The equations given above enable an estimation of the direction and degree of niobium and/or titanium effect on the quantities measured in static tensile test. The form of equations (2) to (5) indicates that the combined or individual increase in the content of both elements reduces the values of $R_{0.2}$ and R_m in cast steel at both ambient temperature as well as at 900 °C, the effect of titanium being definitely much more unfavorable in this respect - equations (3) to (5). Looking for a physical sense of the examined relationships it should be pointed out that an increase in the content of niobium and/or titanium in cast steel results in:

- decrease in the content of fine secondary chromium carbides inside the austenite grains which can play the role of a reinforcing phase;
- increase in the content of phases which, by forming continuous and heavy precipitates on the grain boundaries, exert an adverse effect on the mechanical properties of cast steel;
- increase in the content of phase G; precipitating mainly on the grain boundaries it is responsible for embrittlement at both room and elevated temperatures [11].

In equations (2) - (4) an important effect of carbon and manganese content on the value of the examined relationships can be seen. On the other hand, the silicon content, varying in cast steel over a wide range of values (from 1.3 to 2.5%) has proved to be of no major importance. The

form of equations (6) and (7) does not enable an interpretation as clear as in the case of the previous equations. On the one hand, the elements are present which, when occurring in large amounts in the alloy, can promote the precipitation of phase G [11-12]. On the other hand, like in the case of equation (6), an increase in niobium content bounds carbon into simple carbides, leaving the grains inside free from the secondary precipitates. It can also be expected that the factors which reduce the values of $R_{0.2}$ and R_m of cast steel may simultaneously provoke an increase in ductility.

SUMMARY

The studies performed so far enable drawing of the following conclusions:

1. Introducing niobium and titanium to 0.3 % C - 30 % Ni - 18 % Cr cast steel results in formation in the structure of niobium and titanium carbides with high content of both these elements.
2. The niobium and titanium carbides forming in cast steel are not stable. Due to annealing at 900 °C they are transformed into an intermetallic phase rich in silicon, nickel, niobium and/ or titanium; probably this is the phase G.
3. An increase in the niobium and/ or titanium content is accompanied by a decrease of the yield strength and ultimate strength of cast steel at both ambient temperature and at 900 °C.

REFERENCES

1. B. Mikułowski: Stopy żaroodporne i żarowytrzymałe - Nadstopy, Wydaw. AGH, Kraków (1997)
2. J. Kubicki, B. Piekarski: Metalurgija, 40 (2000) 1, 47-50
3. G. Y. Lai, Heat-Resistant Materials for Furnace Parts, Trays, and Fixtures, ASM Handbook - Heat Treating, (1991) 444, 510-518
4. B. Piekarski: Wpływ Si, Nb i Ti na temperaturę początku i końca krzepnięcia staliwa austenitycznego typu 18/30. Mater. Konf. AMT'92, Stopy żelaza "B", Warszawa - Popowo, (1992) 215-216
5. M. Garbiak, B. Piekarski: Microstructure and mechanical properties of Ni-Cr stabilised austenitic cast steel, Mater. 2nd Inter. Conf., 27-29th April 2000, Tallinn, Estonia, (2000) 244-247
6. M. Garbiak, M., B. Piekarski: Microstructure of as-cast austenitic cast steel type G-X30NiCrSi 30.18 with additions of Nb and Ti. Proceedings of EUROMAT 94, (B. Vorsatz and E. Szöke (Ed.)), Balatonszéplak, Hungary, (1994) 2, 555-559
7. T. Thorvaldsson, G., L. Dunlop: Met. Sci., (1982) 184-190
8. H. Wen-Tai, R. W. K. Honeycombe: Mater. Sci. Technol., (1985) 1, 390-397
9. D. J. Powell, R. Pilkington, D. A. Miller: Acta Metall., (1988) 3, 713-724
10. B. Piekarski: Effect of Nb and Ti additions on microstructure of austenitic cast steel, to be published in Mater. Char. (manuscript)
11. A. Hernas: Żarowytrzymałość stali i stopów - cz. I. Wydaw. Polit. Śląskiej, Gliwice (1999)
12. R. A. P. Ibañez at el.: Mater. Char., (1993) 243-249