

CHANG, M. H.  
JUANG, S. H.



ISSN 0007-215X  
eISSN 1845-5859

## THEORETICAL DESIGN STUDY ON SHAFTING ALIGNMENT CALCULATION FOR HIGH SPEED CRAFT

UDC 629.5.03

Original scientific paper

### Summary

The design reliability of the theory applied when calculating the sensitivity of shafting alignment must be determined especially at the initial design stage of shafting arrangement and calculation for the vertical static bearing loads (reaction forces) and pressures in order to obtain positive uniform values, which have to comply with the design requirements of the High Speed Craft Code of Classification Society. Any poor design of shafting arrangement for each vertical static bearing location and/or bearing off-set design value may cause a failed shafting alignment calculation and a non-uniform bearing load or over excessive bearing load and pressure on the propulsion shaft stern tube/strut supporting bearing and possible further damage, for example, excessive wastage and/or crack on a damaged aft shaft strut bearing for a high speed craft.

The objective of this study was to find and verify the design reliability of the applied theoretical method for calculating the suitable design values of each vertical static bearing load and pressure on the propulsion shafting system at the initial design stage of shafting arrangement. The design values for each vertical static bearing load and pressure calculated by theoretical design methodologies of the finite element method (FEM) and the three moment equation method (TMEM) were compared with the shipyard original design values for the same design case of propulsion shafting system. The design deviation of the vertical static bearing from the shipyard original design values was determined in order to decide which design methodology (TMEM or FEM) would be adopted and developed for further numerical algorithm design on shafting alignment optimization. According to the obtained results, both the FEM and the TMEM theoretical design accuracy and reliability were well matched with the shipyard original design values. In addition, the TMEM design results for each static bearing load and pressure proved to be more close to the shipyard original design values.

Keywords: *high speed craft; shafting alignment calculation; static bearing load; Finite Element Method (FEM); Three Moment Equation Method (TMEM)*

## 1. Introduction

The design task of shafting alignment calculation for high speed craft is one of the most important stages in ship propulsion system designing which may reduce the possibility of propulsion shafting system damage occurrence. The former design experience on shafting alignment calculation and arrangement in the Taiwan shipbuilding industry shows that some of the local shipyard designers still apply the trial-and-error design method for shafting alignment calculation and arrangement at the initial stage of shafting arrangement design. But this design method is not based on engineering knowledge and is generally time-consuming and cost-wasting.

Moreover, the application of the trial-and-error design method may result in failures in design of shafting alignment and arrangement. This may cause the damages of the shafting bearings located on the stern tube bearing or aft shaft strut bearing, or the reduction gear input bearing and output bearing capacity for high speed craft. It can be concluded on the basis of the previous experience on damages that the main reasons causing the excessive wastage and/or crack on the shaft strut bearing and stern tube bearing (Fig. 1) for indirect propulsion shafting system and for direct propulsion shafting system (Fig. 2) are the lack of reliable design information. It also includes inappropriate theoretical design methodology and design program, and other reference design data on shafting alignment calculation by local designers. Therefore, the local designers always entrust the design task of shafting alignment calculation and shafting arrangement to the manufacturers of the main engine, reduction gear or propeller, or to the famous foreign shipyards such as LURSSEEN ASIA to carry out the design and calculation of shafting alignment at the initial stage of shafting arrangement design. This paper highlights the background of this problem in order to provide designers with a reliable design program and research results for the proposed theoretical design methodology of shafting alignment calculation especially at the initial design stage of shafting arrangement and calculation whenever a new design case of propulsion shafting system occurs.

Generally, there are three main design theories for shafting alignment calculation: the finite element method (FEM), the transfer-matrix method (TMM) [1], and the three moment equation method (TMEM). They are used by shipyard designers for calculating the design values of shaft alignment. However, the theoretical design deviations on static bearing load and pressure between the FEM, the TMEM, and the design calculation method adopted by shipyard designers have not been previously studied and determined.

Hence, the presented study compares the design values of vertical static bearing load and pressure obtained by the FEM and TMEM theoretical design with the shipyard original design values based on a straight shaft line without hull deflection [2] for the same design case of the propulsion shafting system of a high speed craft in order to survey and find the design reliability and accuracy of the FEM and TMEM theoretical methodologies. Furthermore, a numerical algorithm design program for automatic optimization of the shafting alignment calculation results has been developed on the theoretical basis of TMEM for a quick design analysis of shafting arrangement and alignment calculation precision [3].

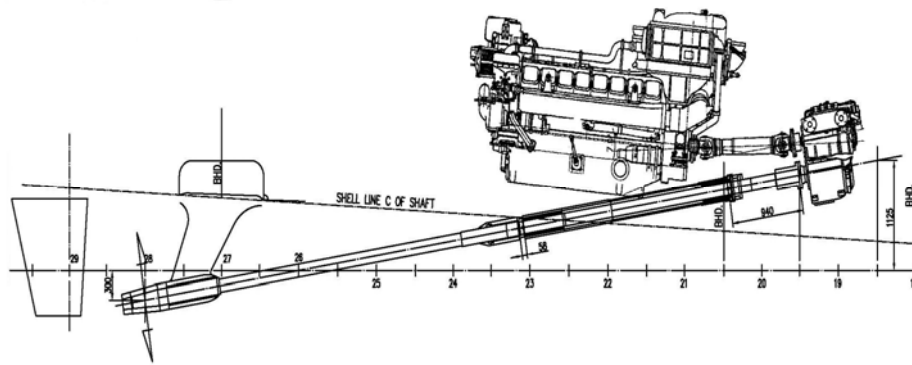

**Figure 1** Indirect propulsion shafting system

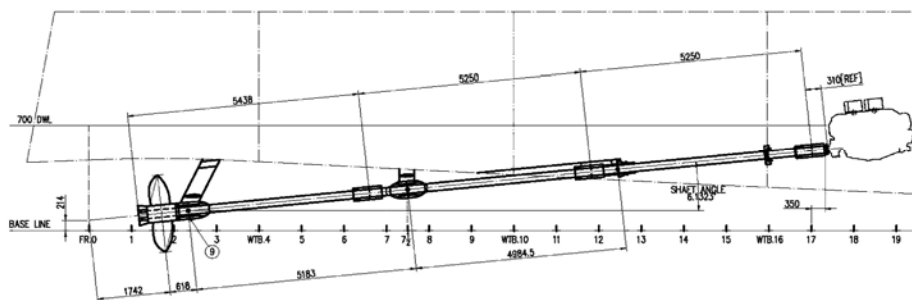

**Figure 2** Direct propulsion shafting system

Apart from the introductory section, this paper is organized as follows. Section 2 describes the design scope, objectives, and the design stipulation of bearing pressure of shafting alignment for high speed craft. The theoretical calculation background for the derivations of FEM and TMEM are given in Section 3. Section 4 compares the FEM and TMEM theoretical design values of each vertical static bearing load and pressure with the original design values from the shipyard specialized in shaft alignment design calculation in order to verify the design accuracy and reliability of the proposed design methodologies. Section 5 presents the shafting numerical analysis results for each vertical static bearing load and pressure and evaluates the difference between the total input shafting loads and the bearing reactions applied on the design shafting system. Some concrete conclusions are given in Section 6.

## 2. Design scope

### 2.1 Definition of high speed craft

According to the International Code of Safety for High Speed Craft, 1994 (1994 HSC Code) adopted by the IMO Maritime Safety Committee, at the 63<sup>rd</sup> session in February 1994, by Resolution MSC.36 (63), and the Amendment as of 2000, the speed defined for high speed craft is expressed in the following formula.

‘High speed craft’ is a craft capable of maximum speed equal to or exceeding [4]:

$$V = 3.7 \nabla^{0.1667} \text{ [m/s]} \quad (1)$$

where

$V$  = Ship speed [m/s]

$\nabla$  = Volume of displacement corresponding to the design waterline [m<sup>3</sup>]

## 2.2 Design objective

(1) The first objective is to design the uniform static bearing load and bearing pressure on positive value for propulsion shafting, especially at the initial design stage of the propulsion shafting calculation and arrangement, and to ensure that the stress loads in the shafting are within the original design range. In addition, the designed shaft static bearing loads and reduction gear bearing loads have to comply with the requirements of the High Speed Craft Code of Classification Society and the requirements of reduction gear manufacturer.

(2) To study and verify the FEM and TMEM theoretical design accuracy and reliability for each static bearing load and pressure in relation to the original design values calculated by the shipyard.

(3) To develop and provide a reliable calculation program and software for the initial design stage of shafting alignment calculation for high speed craft, and also to offer more reliable design information and reference data on shafting alignment for local shipyard designers and the researchers.

## 2.3 Study range for shafting alignment

Generally, the design of shafting alignment is performed in two design stages. The first design stage is the preliminary design and calculation of the uniform bearing load of shafting alignment in order to evaluate and confirm the suitable shafting arrangement at the initial design stage. The second design stage is the onsite shafting installation work of sag and gap calculation after launching [5], which is not being employed in this study. This paper mainly focuses on the initial design stage of shafting alignment considering the bearing load values in vertical plane. The design target is to check whether the vertical static shafting bearing loads are complied with the requirements of the High Speed Craft Code of Classification Society and the original design values set by the shipyard. Thus, this study only focuses on the first design stage of shafting alignment for the direct propulsion, which consists of the reduction gear output bearing, shaft coupling, intermediate shaft, stern tube and its bush bearings, forward and aft shaft struts, propulsion shaft and propeller, as shown in Figure 3 [6].

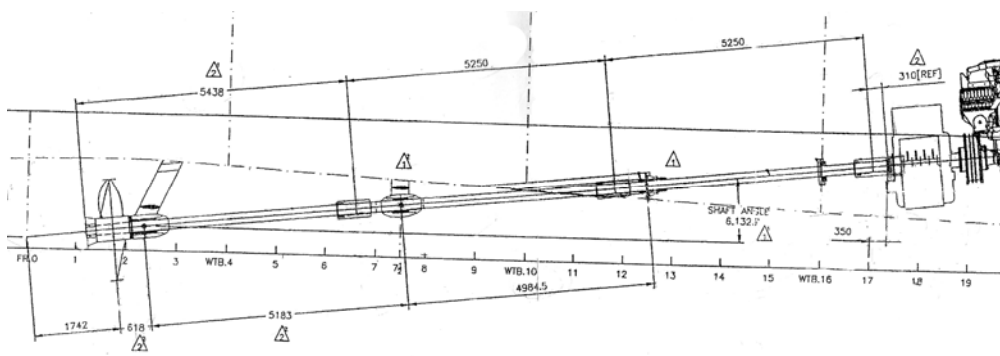

**Figure 3** Direct propulsion shafting system for analysis [6]

## 2.4 Design criteria

In addition, the design bearing pressures must meet the stipulations of the High Speed Craft Code of Classification Society. According to the Rules and Regulations for the Classification of Special Service Craft by Lloyd's Register of Shipping (LR) from 1996 and 2013, the expected nominal bearings' pressures for stern tube bush bearings next to and

supporting the propeller, and for the other design criteria of intermediate shaft bearings and reduction gear wheel bearings are stipulated as follows [7]:

- (1) Nominal design bearing pressures ( $P$ ) for aft shaft strut bearing, forward shaft strut bearing, and stern tube bush bearing next to and supporting the propeller:
  - (a) Approved reinforced resin bush bearings for water lubricated  
 $P \leq 0.55$  [N/mm<sup>2</sup>]
  - (b) Approved white metal bush bearings for oil lubricated  
 $P \leq 0.8$  [N/mm<sup>2</sup>]
  - (c) Approved cast iron and bronze bush bearing for oil lubricated  
 $P \leq$  within the manufacturer specified limits
  - (d) Approved non-metallic bearings  
 $P \leq$  within the manufacturer specified limits
- (2) Intermediate shaft bearings' loads ( $R$ ):  
 $R \leq 80\%$  of the bearing manufacturer's allowable maximum load [N]
- (3) Reduction gear wheel bearings' loads ( $R$ ):  
 $R \leq$  to be within the gearbox manufacturer specified limits [N], usually specified by maximal allowable difference of gearbox output shaft bearing reactions

### 3. Theoretical background

#### 3.1 Finite Element Method (FEM)

The FEM is used for the theoretical derivation of the shafting model. The basic assumptions in this study consider the propulsion shafting as a continuous beam, the supporting bearing as a rigid body, and the hull deformation between the hull and the supporting bearing as an elastic support. Figure 4 shows a beam element with positive nodal displacements, rotations, forces, and moments [8].

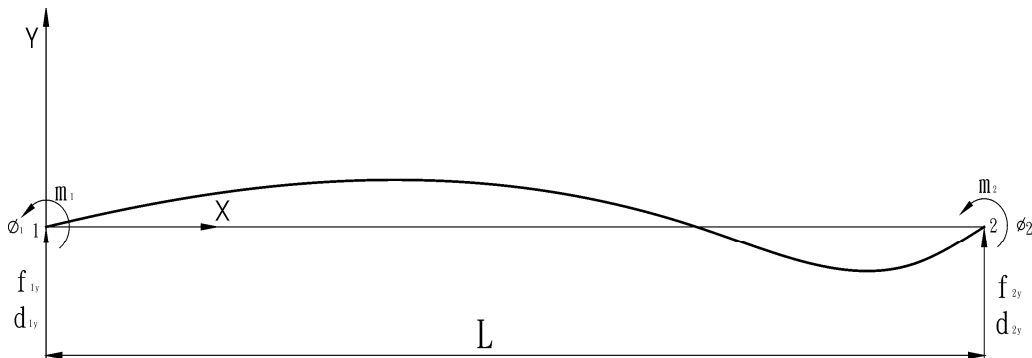

**Figure 4** A beam element with positive nodal displacements, rotations, forces, and moments

Step 1 Select the element type

All nodes in Figure 4 show the sign conventions as follows.

1. Moments ( $m$ ) are positive in the counterclockwise direction [Nm].
2. Rotations ( $\varphi$ ) are positive in the counterclockwise direction.
3. Forces ( $f$ ) are positive in the positive y direction [N].
4. Displacements ( $d$ ) are positive in the positive y direction [mm].

Step 2 Select the displacement function

Each node in Figure 4 has four degrees of freedom, i.e. the transverse displacements  $d_{1y}$  and  $d_{2y}$ , and the small rotations  $\varphi_1$  and  $\varphi_2$  at each node. Assume the transverse displacement variation  $v(x)$  through the element length to be the complete cubic displacement function in Eq. (2).

$$v(x) = a_1 x^3 + a_2 x^2 + a_3 x + a_4 \quad (2)$$

Since the cubic function also satisfies the conditions of displacement and slope continuity at nodes shared by two elements, it thus expresses  $v$  as a function of the nodal degrees of freedom  $d_{1y}$ ,  $d_{2y}$ ,  $\varphi_1$  and  $\varphi_2$  and then obtained equations (3), (4), (5) and (6) read:

$$v(0) = d_{1y} = a_4 \quad (3)$$

$$\frac{dv(0)}{dx} = \varphi_1 = a_3 \quad (4)$$

$$v(L) = d_{2y} = a_1 L^3 + a_2 L^2 + a_3 L + a_4 \quad (5)$$

$$\frac{dv(L)}{dx} = \varphi_2 = 3a_1 L^2 + 2a_2 L + a_3 \quad (6)$$

$\varphi = dv/dx$  is the assumed small rotation. By substituting Eqs. (3), (4), (5), (6) into Eq. (2), it yields

$$v = \left[ \frac{2}{L^3} (d_{1y} - d_{2y}) + \frac{1}{L^2} (\varphi_1 + \varphi_2) \right] x^3 + \left[ -\frac{3}{L^2} (d_{1y} - d_{2y}) - \frac{1}{L} (2\varphi_1 + \varphi_2) \right] x^2 + \varphi_1 x + d_{1y} \quad (7)$$

In matrix form, Eq. (7) is expressed as

$$v = [N] \{d\} \quad (8)$$

where

$$\{d\} = \begin{Bmatrix} d_{1y} \\ \varphi_1 \\ d_{2y} \\ \varphi_2 \end{Bmatrix} \quad (8a)$$

$$\varphi \text{ (slope)} = \frac{dv}{dx} \quad (8b)$$

$$\text{and } [N] = [N_1 \quad N_2 \quad N_3 \quad N_4] \quad (8c)$$

$$\text{in which } N_1 = \frac{1}{L^3} (2x^3 - 3x^2 L + L^3)$$

$$\begin{aligned}
 N_2 &= \frac{1}{L^3} (x^3 L - 2x^2 L^2 + xL^3) \\
 N_3 &= \frac{1}{L^3} (-2x^3 + 3x^2 L) \\
 N_4 &= \frac{1}{L^3} (x^3 L - x^2 L^2)
 \end{aligned} \tag{8d}$$

The  $N_1, N_2, N_3$  and  $N_4$  are called the shape functions for a beam element. The  $\{d\}$  is called transverse displacement vector, which has two components  $d_y$ , and two small rotations  $\phi$  in the positive  $y$  direction.

### Step 3 Relationship between strain/displacement and stress/strain

The following axial strain/displacement relationship is assumed

$$\varepsilon_x (x, y) = \frac{d u}{d x} \tag{9}$$

where  $\varepsilon_x$  is the axial strain, and  $u$  is the axial displacement function. From the deformed configuration of the beam shown in Figures 5 and 6, the relationship between the axial displacement and the transverse displacements is obtained from

$$u = -y \frac{d v}{d x} \tag{10}$$

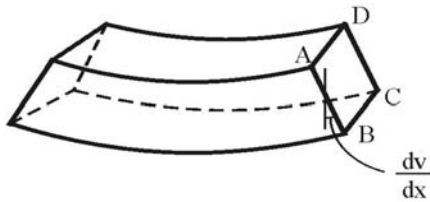

**Figure 5** Beam segment after deformation  
ABCD

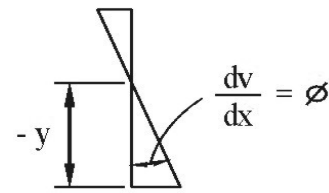

**Figure 6** Rotation angle for cross section

After introducing Eq. (10) into Eq. (9), the axial strain is

$$\varepsilon_x (x, y) = -y \frac{d^2 v}{d x^2} \tag{11}$$

According to the elementary beam theory, the relationships between stress and strain, and stress and moment are as given in Eqs. (12) and (13) respectively.

$$\sigma = \varepsilon \times E \tag{12}$$

$$\sigma = \frac{m y}{I} \tag{13}$$

Introducing Eq. (13) into Eq. (12), the axial strain is expressed as

$$\varepsilon = -\frac{m y}{E I} \tag{14}$$

Applying Eq. (11) into (14) yields

$$m (x) = E I \frac{d^2 v}{d x^2} \tag{15}$$

$$V = EI \frac{d^3 v}{dx^3} \quad (16)$$

where

$$\begin{aligned} \sigma &= \text{stress of beam [N/mm}^2\text{]} \\ E &= \text{Young's modulus [N/mm}^2\text{]} \\ I &= \text{area moment of inertia of beam element [mm}^4\text{]} \\ m(x) &= \text{bending moment of beam element [N-m]} \\ V &= \text{shear force of beam element [N/mm}^2\text{]} \end{aligned}$$

#### Step 4 Derivation of the element stiffness matrix and element equation

Equations (15) and (16) are used to derive the beam stiffness matrix and equations by a direct equilibrium approach into Eq. (17).

$$\begin{aligned} f_{1y} &= V = EI \frac{d^3 v(0)}{dx^3} \\ &= \frac{EI}{L^3} (12d_{1y} + 6L\varphi_1 - 12d_{2y} + 6L\varphi_2) \\ m_1 &= -m = -EI \frac{d^2 v(0)}{dx^2} \\ &= \frac{EI}{L^3} (6Ld_{1y} + 4L^2\varphi_1 - 6Ld_{2y} + 2L^2\varphi_2) \\ f_{2y} &= -V = -EI \frac{d^3 v(L)}{dx^3} \\ &= \frac{EI}{L^3} (-12d_{1y} - 6L\varphi_1 + 12d_{2y} - 6L\varphi_2) \\ m_2 &= m = EI \frac{d^2 v(L)}{dx^2} \\ &= \frac{EI}{L^3} (6Ld_{1y} + 2L^2\varphi_1 - 6Ld_{2y} + 4L^2\varphi_2) \end{aligned} \quad (17)$$

Equation (17) is expressed as a matrix form in Eq. (18).

$$\begin{Bmatrix} f_{1y} \\ m_1 \\ f_{2y} \\ m_2 \end{Bmatrix} = \frac{EI}{L^3} \begin{bmatrix} 12 & 6L & -12 & 6L \\ 6L & 4L^2 & -6L & 2L^2 \\ -12 & -6L & 12 & -6L \\ 6L & 2L^2 & -6L & 4L^2 \end{bmatrix} \begin{Bmatrix} d_{1y} \\ \varphi_1 \\ d_{2y} \\ \varphi_2 \end{Bmatrix} \quad (18)$$

The element stiffness matrix [κ] in Eq. (18) is

$$[K] = \frac{EI}{L^3} \begin{bmatrix} 12 & 6L & -12 & 6L \\ 6L & 4L^2 & -6L & 2L^2 \\ -12 & -6L & 12 & -6L \\ 6L & 2L^2 & -6L & 4L^2 \end{bmatrix} \quad (19)$$

However, the influence of shear forces on the deflections expressed by shear coefficients have been neglected in Eq. 19 for the reason of high bearing span to shaft



diameter. In addition, the bending effect on the shafting system is more significant than that caused by shear forces.

### 3.2 Three Moment Equation Method (TMEM)

The TMEM theoretical derivation is also applied to the same shafting analysis model used in the numerical analysis. The basic assumptions in the TMEM are the same as those in the FEM. Figure 7 shows a free body diagram of the beam element, in which the basic assumptions are positive nodal displacements, rotations, forces, and moments.

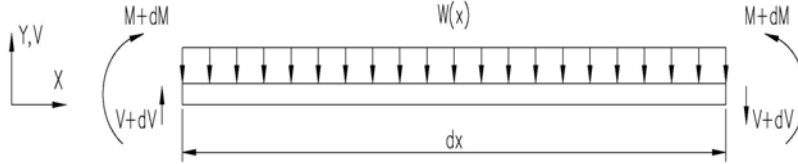

**Figure 7** A free body diagram of beam element

Figure 8 shows that the continuous beam method is the basic design principle of the TMEM when calculating the shafting alignment for the propulsion shafting system. This propulsion shafting system is considered as a continuous beam supported by three fixed supporting points. The symbol  $N$  indicates a middle supporting point in the beam. The  $N-1$  means a supporting point is on the left side, and the  $N+1$  means a supporting point is on the right side along with its beam length of segment  $L_N$  and  $L_{N+1}$  on each end separately. The symbols of  $W_N$  and  $W_{N+1}$  are the uniform load acting on the lengths of segments  $L_N$  and  $L_{N+1}$  on each end, respectively. In this case, two concentrated loads of  $P_N$  and  $P_{N+1}$  are simultaneously acting along the lengths of segments  $L_N$  and  $L_{N+1}$  on each span.

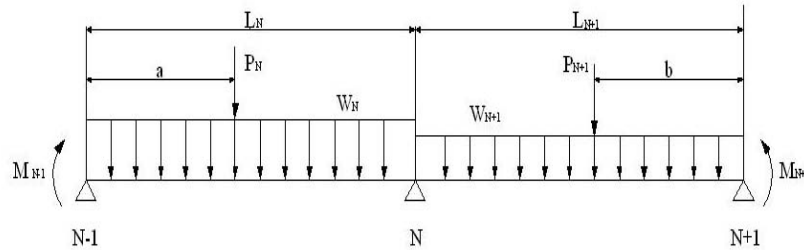

**Figure 8** Illustration for shafting analysis by TMEM

Considering a continuous beam with the deflection angle  $\theta_N = \theta'_N$  at the  $N$  supporting point, the reaction forces at the  $N$  supporting point are obtained from the principle of superposition for  $R_N$  and  $R'_N$  on either sides of this  $N$  supporting point with the offset influence angles of  $\beta_N$  and  $\beta_{N+1}$  [3]. The resulting expression is

$$\begin{aligned}
 & M_{N-1} \left( \frac{L_N}{I_N} \right) + 2M_N \left( \frac{L_N}{I_N} + \frac{L_{N+1}}{I_{N+1}} \right) + M_{N+1} \left( \frac{L_{N+1}}{I_{N+1}} \right) \\
 &= - \frac{W_N L_N^3}{4I_N} - \frac{W_{N+1} L_{N+1}^3}{4I_{N+1}} - \frac{P_N a}{L_N I_N} (L_N^2 - a^2) \\
 & - \frac{P_{N+1} b}{I_{N+1} L_{N+1}} (L_{N+1}^2 - b^2) - 6E \left( \frac{\delta_{N-1} - \delta_N}{L_N} + \frac{\delta_{N+1} - \delta_N}{L_{N+1}} \right)
 \end{aligned} \tag{20}$$

The corresponding reaction force to the  $N$  supporting point for this continuous beam is

$$R_N = \frac{M_{N-1} - M_N}{L_N} + \frac{M_{N+1} - M_N}{L_{N+1}} + \frac{P_N a}{L_N} \quad (21)$$

$$+ \frac{P_{N+1} b}{L_{N+1}} + \frac{W_N L_N}{2} + \frac{W_{N+1} L_{N+1}}{2}$$

- $M$  = bending moment on each supporting bearing [N-m]
- $L$  = span length between each supporting bearing point [mm]
- $W$  = weight of distribution load on each shaft [N]
- $I$  = moment of inertia of beam element [mm<sup>4</sup>]
- $P$  = concentrated loads acting on shaft [N]
- $A$  = length distance between concentrated load  $P_n$  to the supporting bearing point  $N-1$  [mm]
- $b$  = length distance between concentrated load  $P_{n+1}$  to the supporting bearing point  $N+1$  [mm]
- $\delta$  = off-set values on each supporting bearing point to the shafting straight line on propulsion shafting system [mm]
- $R$  = reaction force on each supporting bearing point [N]
- $\theta$  = deflection angle on each supporting bearing point [rad]
- $\beta$  = offset influence angle of each supporting bearing point on the shafting system [rad]

Equations (20) and (21) are named as Clapeyron's theorem. Finally, this theory is applied for obtaining the bearing loads and bending moments when calculating the shafting alignment for high speed craft.

#### 4. Numerical analysis

FEM numerical analysis software, ANSYS Workbench, and the coding TMEM design program, which are based on different theories, are used to calculate the vertical static bearing loads and pressures for this modeling design case of high speed patrol boat propulsion shafting system. Some numerical results are presented in detail in the sections that follow.

##### 4.1 Modeling analysis of propulsion shafting

In accordance with the shipyard original design calculation model of the shafting alignment based on a cold straight shaft line for the initial design stage, Figures 9 and 10 show a direct propulsion shafting system and its modeling for the purpose of analysis.

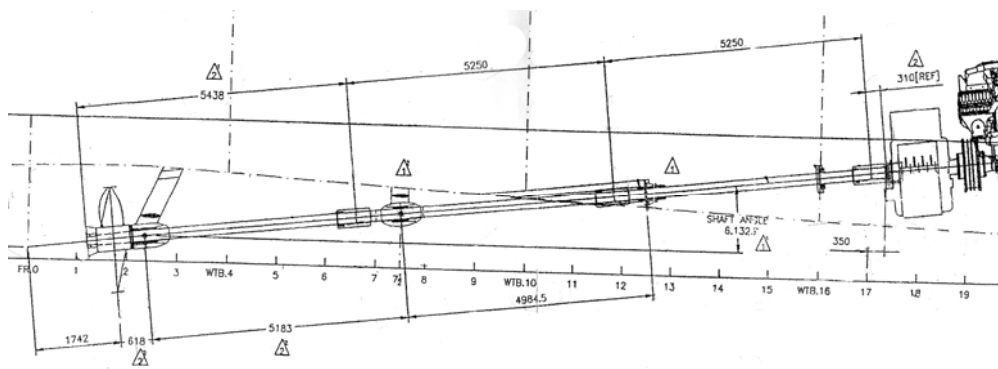
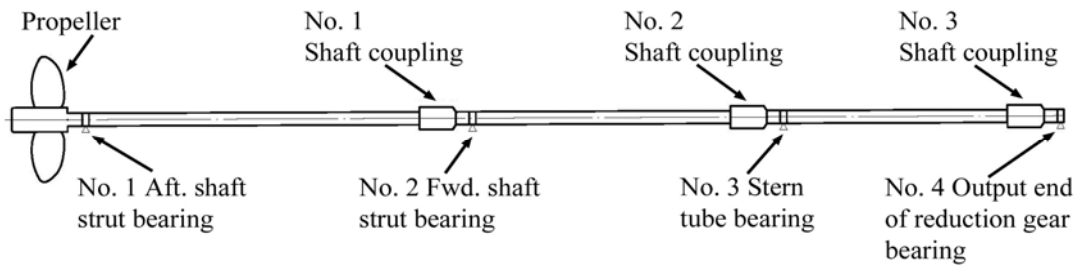

Figure 9 Direct propulsion shafting system



**Figure 10** Direct propulsion shafting model for analysis

#### 4.2 Design input shafting data and particulars

It consists of the reduction gear output shaft bearing, three shaft couplings, two intermediate shafts, stern tube and its bush bearings, one propulsion shaft, one forward shaft struts and its bearing, one aft shaft struts and its bearing, and one propeller.

The design input parameters and the shafting alignment data for a built high speed patrol boat and its ship particulars are as follows:

- (1) Two intermediate shafts:  
205 [mm] ( $\phi$ )  $\times$  5.250 [mm] (L)  $\times$  13390 [N] (1365 Kgf) / each shaft
- (2) One propeller shaft:  
205 [mm] ( $\phi$ )  $\times$  5438 [mm] (L)  $\times$  13489 [N] (1375Kgf)
- (3) Material of intermediate shaft and propeller shaft:  
Aquamet 22 Stainless Steel
- (4) Mechanical properties:  
Young's modulus: 209 [GPa]  
Mass Density:  $7.85 \times 10^{-6}$  [Kg/mm<sup>3</sup>]  
Tensile Yield: 379 [MPa]  
Tensile Ultimate: 689 [MPa]  
Poisson's Ratio: 0.272
- (5) Weight of propeller: 12802 [N] ( 1.305 Kgf )
- (6) Three shaft couplings:  
Weight of shaft coupling: 2796 [N] ( 285 Kgf ) / each
- (7) Weight of propeller and tail shaft from the center of aft shaft strut to the aft end of tail shaft: 15941[N] ( 1625 Kgf )
- (8) Bending moment on outer end of propeller: 100440 [N-m]
- (9) Distance between outer end of propeller and center of aft shaft strut: 1236 [mm]
- (10) Distance between center of aft shaft strut and center of forward shaft strut: 5183 [mm]
- (11) Distance between center of forward shaft strut and stern tube bearing: 4984.5 [mm]
- (12) Distance between center of stern tube bearing and reduction gear output shaft bearing: 5225 [mm]
- (13) Distance between center of aft shaft strut and first shaft coupling: 4276 [mm]

- (14) Distance between center of forward shaft strut and second shaft coupling: 4400 [mm]
- (15) Distance between center of stern tube bearing and third shaft coupling: 4700 [mm]

### 4.3 FEM analysis

In the first design approach, a 3D drawing software (Solid Works) was used to model the direct propulsion shafting system according to the shafting system design drawing and arrangement. Secondly, the numerical analysis software from ANSYS Workbench was applied for the analysis of the static bearing loads, the shafting maximum and minimum equivalent stress and shear force, the design safety factor, etc, in the shafting system. Figure 11 shows the meshes condition when the shafting model is discretized into different elements for the numerical analysis performed by the auto-mesh function from the numerical analysis software from ANSYS Workbench.

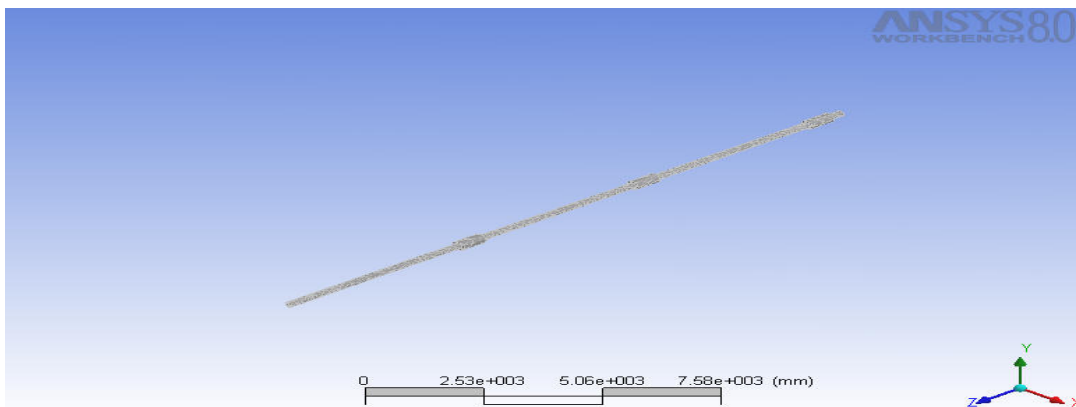

**Figure 11** Geometry analysis model of shafting

After the meshing analysis is completed in the shaft model, the ANSYS Workbench software was applied for solving the numerical solution to the propulsion shafting system, and to display the bearing stress loads in the propulsion shafting initial design stage. The numerical results highlighted in this study include the equivalent stresses, shear forces, maximum deformation and safety factor for this shafting system.

Figure 12 demonstrates that, under a static load and straight shaft line condition, the maximum equivalent stress is on the output end of the reduction gear shaft bearing (23.527 MPa), and the minimum equivalent stress is on the outer end of the aft propulsion shaft strut bearing (1411.2 Pa).

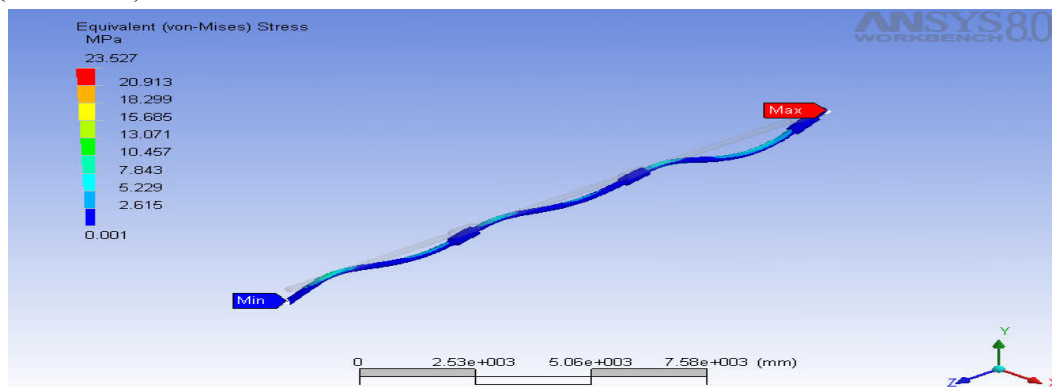

**Figure 12** Maximum and minimum equivalent stress and their location on shafting

Figure 13 shows that the maximum shear stress (12.728 MPa) is located on the output end of the reduction gear shaft bearing. The minimum shear stress (622 Pa) is on the outer end of aft propulsion shaft strut bearing for a straight shaft line under a static load.

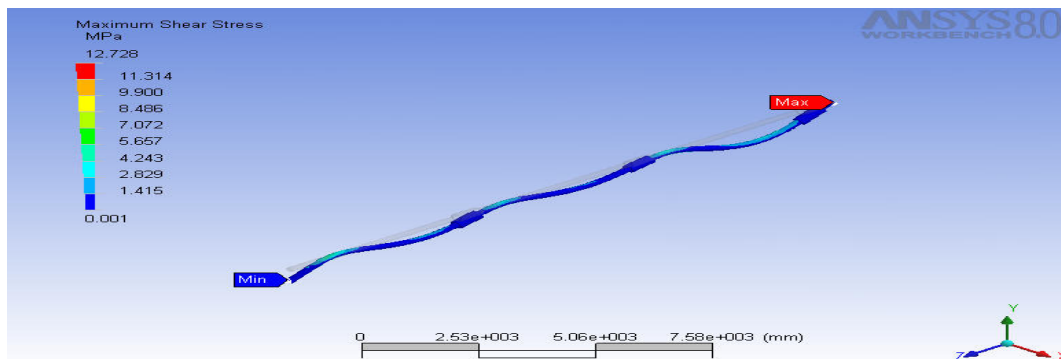

**Figure 13** Maximum and minimum shear stress and their location on shafting

Figure 14 shows that the maximum deformation (0.462 mm) is located between the output end of the reduction gear shaft bearing and the stern tube bush bearing in the straight shaft line condition.

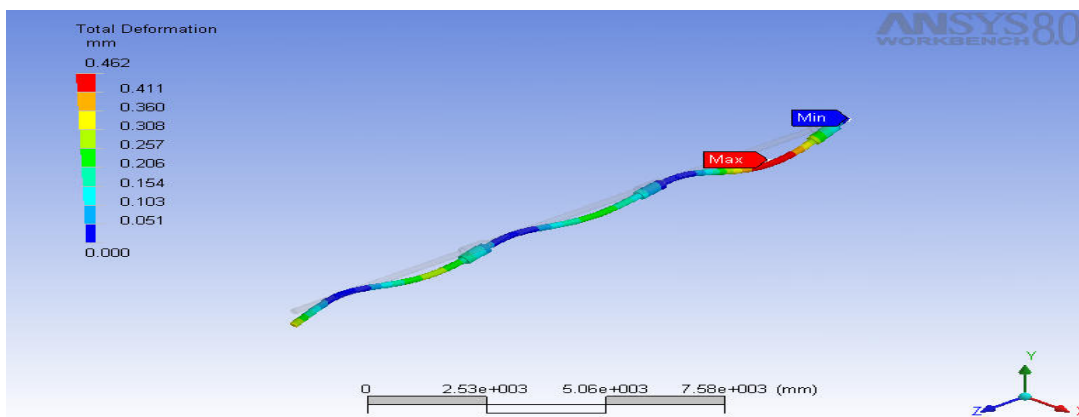

**Figure 14** Maximum deformation and its location on shafting

Figure 15 shows that the minimum safety factor to this shafting defined with respect to the allowable stresses dependent upon shafting material properties is 15 and it is located on the outer end of the aft propulsion shaft strut bearing in the straight shaft line condition. The safety factor to the whole shafting is higher than the requirement listed in the mechanical design handbook.

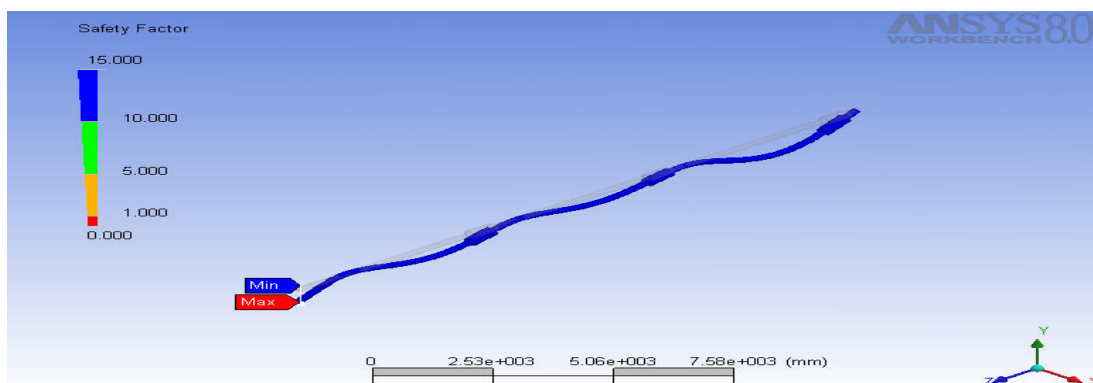

**Figure 15** Minimum safety factor and its location on shafting

Moreover, Table 1 shows the deviation values of the each design static bearing load obtained by the FEM numerical analysis and original design values proposed by the shipyard [9].

**Table 1** Deviation in bearing loads obtained by FEM and shipyard original design values

Bearing Nos. Design method and deviation	No. 1 Aft shaft strut bearing	No.2 Forward shaft strut bearing	No.3 Stern tube bearing	No.4 Reduction Gear output shaft bearing
FEM	23547 N	15646 N	16756 N	8004 N
Shipyard original design	22035 N	14313 N	18482 N	7681 N
Deviation value of design bearing load	1512 N	1333 N	-1726 N	323 N

Table 2 shows the values for the design bearing load and bearing pressure obtained by ANSYS Workbench for each fixed bearing point.

**Table 2** Bearing loads and pressures obtained by FEM

Bearing Nos. Design criteria	No. 1 Aft shaft strut bearing	No.2 Forward shaft strut bearing	No.3 Stern tube bearing	No.4 Reduction Gear output shaft bearing
Bearing length (mm)	500	300	300	---
Shaft diameter (mm)	205	205	205	---
Bearing loads (N)	23547 N	15646 N	16756 N	8004 N
Bearing pressure (N/mm <sup>2</sup> )	0.230 N	0.254 N	0.272 N	---
HSC Rule requirements of bearing pressure (N/mm <sup>2</sup> )	≤ 0.55	≤ 0.55	≤ 0.55	Maker requirements

Clearly, the analysis results fully comply with the 0.55 N/mm<sup>2</sup> bearing pressure specified by the High Speed Craft (HSC) Code of Classification Society and are very close to the shipyard original design values in a static straight shaft line condition.

#### 4.4 TMEM analysis

The computer program TMEM based on new theory is applied to solve each static bearing load and pressure for the shafting alignment calculation in the same design case of shafting system for a high speed patrol boat (Fig. 16).

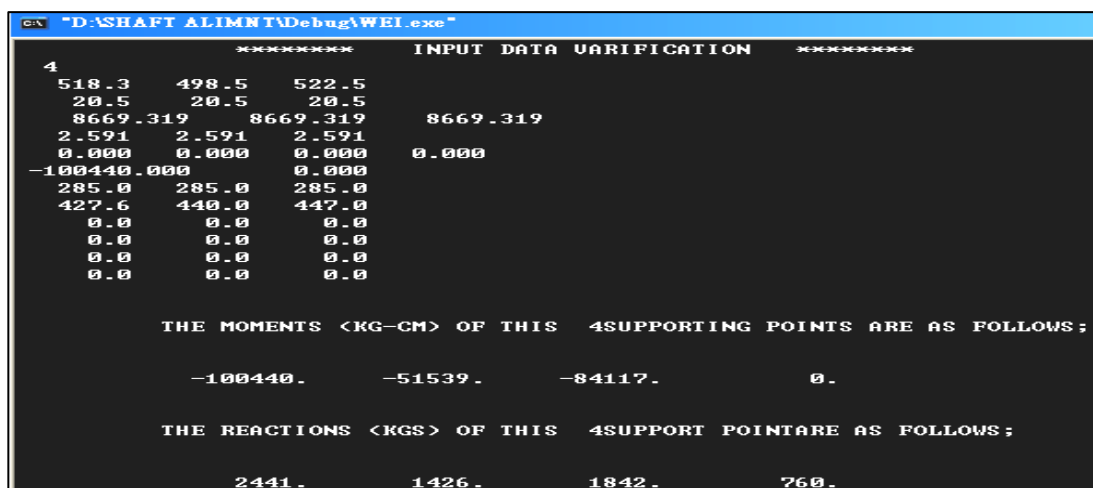

**Figure 16** TMEM analysis results for shafting bearing load

Table 3 shows the deviation of the static bearing loads obtained by TMEM design program from the original design values proposed by the shipyard.

**Table 3** Deviation in bearing loads obtained by TMEM from shipyard original design values

<b>Design method and deviation</b>	<b>Bearing Nos.</b>	<b>No. 1 Aft shaft strut bearing</b>	<b>No.2 Forward shaft strut bearing</b>	<b>No.3 Stern tube bearing</b>	<b>No.4 Reduction Gear output shaft bearing</b>
TMEM		23922 N	13975 N	18052 N	7448 N
Shipyard original design		22035 N	14313 N	18482 N	7681 N
Deviation value of esign bearing load		1887 N	-338 N	-430 N	-233 N

Table 4 shows the analysis results for bearing loads and bearing pressures obtained by TMEM design program.

**Table 4** Bearing loads and pressures obtained by TMEM

<b>Design criteria</b>	<b>Bearing Nos.</b>	<b>No. 1 Aft shaft strut bearing</b>	<b>No.2 Forward shaft strut bearing</b>	<b>No.3 Stern tube bearing</b>	<b>No.4 Reduction Gear output shaft bearing</b>
Bearing length (mm)		500	300	300	---
Shaft diameter (mm)		205	205	205	---
Bearing loads (N)		23922 N	13975 N	18052 N	7448 N
Bearing pressure (N/mm <sup>2</sup> )		0.233	0.227	0.293 N	---
HSC Rule requirements of bearing pressure (N/mm <sup>2</sup> )		≤ 0.55	≤ 0.55	≤ 0.55	Maker requirements

The obtained results expressing the design bearing loads and pressures shown in Table 4 are also consistent with the requirements of 0.55 N/mm<sup>2</sup> bearing pressure stipulated by the High Speed Craft (HSC) Code of Classification Society, and are also very close to the shipyard original design values.

## 5. Results and discussion

That the design target for the analysis was to verify FEM and TMEM design deviation values for vertical static bearing loads and pressures in relation to the shipyard original design values. These design theories are applied for calculating and designing a sensitive shafting system especially at the initial design stage of shafting arrangement. The main purpose of this study was mainly to provide shipyard designers with reliable design information and data based on shafting alignment calculation tools and design theoretical methodologies in order to enable them to make the design of shafting alignment in accuracy and without further damage to the shafting supporting bearing and reduction gear bearing.

The FEM, TMEM and shipyard original design calculation results for the same design case of propulsion shafting system show that the difference and deviation percentage between the total input shafting loads and the bearing reactions are -0.11%, -0.98% and -2.36% , respectively (Table 5), that is, the design accuracy of the modeling analysis of design shafting has been verified. In design practice of shafting alignment calculation, the difference and deviation in shafting design should be within ± 2.5% of design margin.

**Table 5** Difference between total input shafting loads and the bearing reactions applied on the design shafting system

Shafting analysis method			
Difference between total input shafting loads and the bearing reactions	FEM	TMEM	Shipyards original design
Total input shafting weight	64025 N	64025 N	64025 N
Total bearing reaction loads	63953 N	63397 N	62511 N
Deviation percentage of design input shafting loads and the bearing reactions	-0.11%	-0.98%	-2.36%

The vertical static bearing load designed in this study verifies that the deviation in static bearing load is lower than  $\pm 10\%$  of the maximum acceptable bearing load deviation from the shipyard original design. It also verifies that the results for each static bearing load comply with the requirements of the High Speed Craft Code of Classification Society (Table 6).

**Table 6** The deviations in bearing loads obtained by FEM and TMEM from the shipyard original design values

Bearing Nos.	No.1 Aft shaft strut bearing	No.2 Fwd shaft strut bearing	No.3 Stern tube bearing	No.4 output end reduction gear bearing
Design bearing loads deviation				
FEM	6.86%	9.31%	-9.33%	4.20%
TMEM	8.56%	-2.36%	-2.33%	-3.03%
Shipyards original design	22035 N	14313 N	18482 N	7681 N

## 6. Conclusions

The main conclusions of this study are outlined as follows.

(1) The advantage of applying ANSYS Workbench numerical analysis software reveals the whole design shafting condition for analysis. It clearly indicates and illustrates the maximum and maximum equivalent stress, shear force, and location of shafting deformation associated with the minimum safety factor on this shafting system. The FEM can be selected in one-dimensional, two-dimensional, or three-dimensional analysis, depending on problem characteristics. However, the TMEM is based on one-dimensional assumptions. In general, one-dimensional approach is more conservative, that is, the design may be over-designed in size. As for drawbacks, the FEM must be run on the computer to obtain the design data, and it also takes time to precisely model a 3D meshing model by software for further numerical analysis. On the contrary, the TMEM is more time and costing saving for executing the design analysis of shafting alignment calculation by its coding design program.

(2) The applied FEM and TMEM design theories verified that the vertical static bearing loads and pressures are matched well with the shipyard original design values calculated for the same shafting design case. The maximum and minimum deviation of vertical static bearing load is located on the stern tube bearing. That is, the maximum deviation of vertical static bearing load is -9.33% for the FEM analysis, and the minimum one is -2.33% for the TMEM. This deviation value is less than  $\pm 10\%$  of the maximum acceptable bearing load deviation in practical design for shafting alignment calculation. In addition, this study also



verified that the design bearing pressure was within a uniform positive value and that it complied with the Rule's design requirements of  $0.55\text{N/mm}^2$  of bearing pressure for the High Speed Craft Code of Classification Society.

(3) The deviations between total input shafting loads and bearing reactions applied on the same design shafting system were found to be  $-0.11\%$  for the FEM analysis and  $-0.98\%$  for the TMEM analysis, which is better than the shipyard original design value of  $-2.36\%$ . Moreover, the FEM and TMEM design results for the difference and deviation percentage between total input shafting loads and the bearing reactions are also lower than the value of  $\pm 2.5\%$  in shipyard design practice.

(4) The design results of TMEM design vertical static bearing load and pressure are more close to the shipyard original design values. Hence, a further numerical algorithm program for automatic optimization of design values for each static supporting bearing load, bearing pressure, bearing location and bearing vertical off-set is developed for such a theoretical basis to enable a quick and precise design analysis for shafting alignment calculation and arrangement

## REFERENCES

- [1] Vulić, N.: "Modeling of Propulsion Shaft Line and Basic Procedure of Shafting Alignment Calculation", Brodogradnja, Vol. 59, No.3, (2008), pp. 223-227.
- [2] Low, K.H., and Lim, S.H.: "Propulsion Shaft Alignment Method and Analysis for Surface Crafts", Advances in Engineering Software, Vol. 35, (2004), pp. 45-58.
- [3] Juang, S.H., Chang, M.H., and Huang, J.C.: "Applying the ARPSO Algorithm to Shafting Alignment Optimization Design", Brodogradnja, Vol. 63, No.2, (2012), pp. 140-152.
- [4] "Resolution of MSC.36(63), and its Amendments MSC.175(70) and MSC.222(82)", Maritime Security Committee (MSC), International Code of Safety for High Speed Craft.
- [5] Wei, W.M.: "Technical Research on Shafting Alignment of Long-Stroke and Large-Bore Marine Main Diesel Engine of Regular Vessel", Journal of Marine Sciences, Vol. 3, (1995), pp. 67-113.
- [6] Ching Fu Shipbuilding Co., Ltd., "K4300401 Shafting Arrangement", (2000).
- [7] Lloyd's Register of Shipping (LR), "Rules and Regulations for Classification of Special Service Craft", Part 11 Chapter 2 and Part 13 Chapter 4, (1996 and 2013).
- [8] Logan, D.L.: Finite Element Method, 3rd ed. (2002), Brooks/Cole.
- [9] Ching-Fu Shipbuilding Co., Ltd., "K4300404 Shafting Alignment Calculation", (2000).

Submitted: 11.04.2014

Accepted: 15.08.2014

CHANG, M.H. (First Author) [mhchang@crclass.org](mailto:mhchang@crclass.org)  
JUANG, S. H. (Corresponding Author) [shjuang@mail.ntou.edu.tw](mailto:shjuang@mail.ntou.edu.tw)  
Dept. of Mechanical & Mechatronic, National Taiwan Ocean University  
2, Pein-Ning Road, Keelung 20224, Taiwan, R.O.C.