

# DETERMINATION OF SUBSTRATE LOG-NORMAL DISTRIBUTION IN THE AZ91/SiC<sub>p</sub> COMPOSITE

Received – Prispjelo: 2014-02-29  
Accepted – Prihvaćeno: 2014-07-15  
Preliminary Note – Prethodno priopćenje

The aim in this work is to develop a log-normal distribution of heterogeneous nucleation substrates for the composite based on AZ91 alloy reinforced by SiC particles. The computational algorithm allowing the restore of the nucleation substrates distribution was used. The experiment was performed for the AZ91 alloy containing 1 % wt. of SiC particles. Obtained from experiment, the grains density of magnesium primary phase and supercooling were used to algorithm as input data.

**Key words:** The AZ91/SiC<sub>p</sub> composite, particle, heterogeneous nucleation, log-normal distribution of substrate.

## INTRODUCTION

The AZ91/SiC<sub>p</sub> composites, with their lower density and good mechanical properties, are more attractive material for automobile and aerospace industries. The grain size of magnesium primary phase in these composites substantially affects their mechanical properties. The effect of the SiC particles in refining the grain size in the matrix phase is not attributed only to enhanced nucleation. There are other effects such as restriction of grain growth arising from the pushing of particles. Particles being pushed could, for example, impede solute redistribution at the solid-liquid interface [1].

The literature offers many examples of the application of the simulation method for the heterogeneous nucleation. One of this method is based on the hemispherical cap model proposed by Greer et al. [2, 3]. It allows a prediction of the grain size as a function of the particle size log-normal distribution, the volumetric content of ceramic inoculants, the cooling rate and the alloy constitution. Because used size of SiC particles (45 μm) and fact that these particles are not good inoculants for AZ91 alloy, the aim in this work is to develop a log-normal distribution of heterogeneous nucleation substrates and given by the following formula:

$$N(d) = \frac{N_0}{\sigma \cdot d \sqrt{2\pi}} \cdot \exp\left(-\frac{(\ln(d) - \ln(d_0))^2}{2 \cdot \sigma^2}\right) \quad (1)$$

where:  $N_0$  – total population of nucleation substrate / m<sup>-3</sup>;  $d_0$  – geometric mean of log-normal distribution / m;  $\sigma$  – geometric standard deviation of log-normal distribution;  $d$  – mean diameter of nucleation substrate / m.

## EXPERIMENTAL METHODS

The magnesium alloy AZ91 was selected as the matrix for this work, Table 1.

Table 1 **The chemical composition of AZ91**

Chemical composition / wt. %						
Al	Zn	Mn	Si	Fe	Cu	Ni
9,0	0,6	0,2	0,03	0,002	0,003	0,001

The sample contained 1 wt % sharp SiC particles (from Polmineral) with nominal arithmetic mean diameters of 45 μm. The AZ91 alloy was melted in a steel crucible, using an electric resistance furnace filled with SF<sub>6</sub> / CO<sub>2</sub> shielding gas, and kept at 700 °C for one hour before adding the SiC particles pre-heated to 450 °C. The melt was mechanically stirred for two minutes to ensure a uniform distribution of the SiC particles (similar to the procedure of Luo [4]), and then cast into a resin-hardened sand mould [5, 6]. The mould was designed to produce four 100 x 100 mm plates with a thickness of 10, 15, 20 or 30 mm, giving a range of cooling rates.

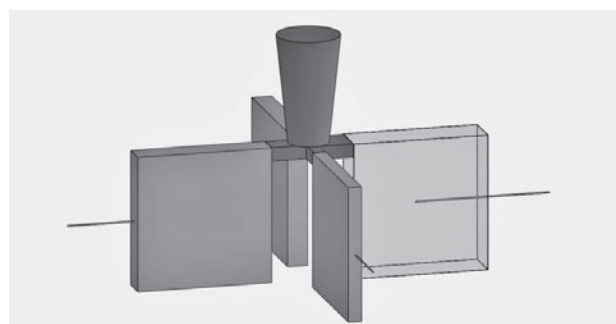

**Figure 1** Gating system and model of four plates used for casting four 100 x 100 mm<sup>2</sup> composite plates with thicknesses of 10, 15, 20 or 30 mm

J. Lelito, P. L. Źak, B. Gracz, M. Szucki, D. Kalisz, P. Malinowski, J. S. Suchy, W. K. Krajewski. AGH University of Science and Technology, Faculty of Foundry Engineering, Kraków, Poland

To obtain the cooling curves of the samples, a four-channel data-logging system with an acquisition rate of five readings per second was used to record the change in temperature vs. time from a K-type thermocouple positioned in the centre of each plate (approx. 50 mm above the base plate shown in Figure 1). A number of cuboid samples with a cross section of 35 × 35 mm<sup>2</sup> and height of 45 mm. The thermocouple was located in the centre of the cuboid crucible.

Metallographic specimens, taken from the cast plates at a distance of 3 mm from the hot junction of the embedded thermocouples, were ground and polished using conventional preparation methods, and then etched at room temperature. The specimens for grain density measurement were etched for about 90 s in a solution containing 50 ml distilled water, 150 ml ethanol and 1 ml ethanoic acid [1]. The etched specimens were examined in white polarized light (using crossed polars and a first-order retardation plate). The planar grain density was measured using the image-analysis software NIS-Elements 3.0. The planar grain density  $N_A$  was obtained from a population of 100 grains, and the volumetric density  $N_V$  is calculated from  $N_A$  using equation (2).

$$N_V = \frac{2}{\pi} N_A \left( \frac{1}{l} \right)_{\text{mean}} \quad (2)$$

where:  $(1/l)_{\text{mean}}$  is the mean value of the inverse diameters of all observed grain intercepts.

### COMPUTATIONAL ALGORITHM

The developed algorithm is based on next input data: experimental values characterizing the composite (maximal supercooling, grain densities), thermodynamic parameters of the composite (volumetric entropy of fusion and interfacial energy at the boundary liquid/crystallite) and assumed total number of nucleation substrates ( $N_0$ ), interval of substrate size ( $D_{\text{min}} - D_{\text{max}}$ ), within which a value of geometric mean will be looking for, interval of a standard deviation, integration step, maximal number of integration steps and the assumed tolerance for integral calculations accuracy.

The supercooling at which a nucleation substrate becomes active is that at which there can be free growth of the nucleated grain from the substrate. Greer et al. suggested that this critical supercooling is inversely proportional to the nucleation substrate diameter [2]:

$$\Delta T_{fg} = \frac{4 \sigma_{lc}}{\Delta S_V d} \quad (3)$$

where:  $\Delta T_{fg}$  - free growth supercooling, K,  $\sigma_{lc}$  - interfacial energy on the boundary, Jm<sup>-2</sup>,  $\Delta S_V$  - entropy of fusion per unit volume, Jm<sup>-3</sup>K<sup>-1</sup>.

Thus, on cooling an alloy containing nucleation substrates, nucleation occurs first on the largest substrates. The equation (3) allows determining the minimal dimension of the substrate  $d_{\text{mini}}$  and can be described by:

$$d_{\text{min}}^i = \frac{4 \sigma_{lc}}{\Delta S_V \Delta T_{\text{max}}^i} \quad (4)$$

Basing on equation (1), value of misfit functional  $J(\sigma_i, d_0^k)$  can be calculated:

$$J(\sigma^i, d_0^k) = \sum_{i=1}^n [N_V^i - N_{Vt}^i(\sigma^i, d_0^k)]^2 \quad (5)$$

where:  $N_V^i$  - experimental grain density, m<sup>-3</sup>,  $N_{Vt}^i$  - theoretical grain density calculated by numerical integration of equation (1), m<sup>-3</sup>:

$$N_{Vt}^i(\sigma^i, d_0^k) = \int_{d_{\text{min}}^i}^{+\infty} N(d, \sigma^i, d_0^k, N_0) \delta d \quad (6)$$

In other words, the computational algorithm generates a sequence of distribution depended on the distribution geometrical mean, on the standard deviation and on the previously assumed  $N_0$ , and then allows to determine the theoretical density of active nucleation substrates (integral of lower limit  $d_{\text{min}}$ ). The misfit functional (5), enabling the selection of the distribution the best resembling the actual distribution of the heterogeneous nucleation substrate in the given composite. The graphical diagram of the developed algorithm was presented by Gracz [7] and show in the Figure 2.

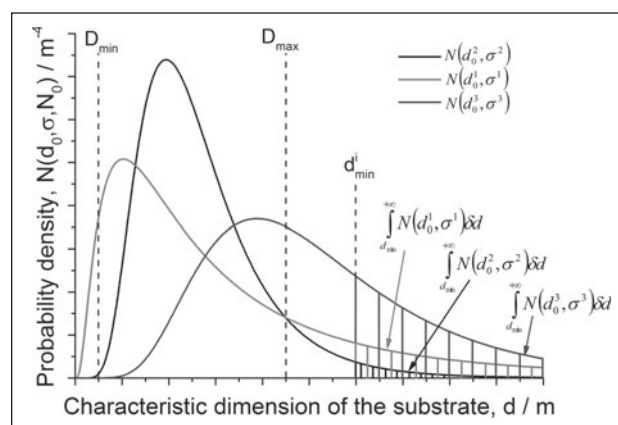

Figure 2 Diagram of the computational algorithm [7]

### RESULTS

The input data for presented computational algorithm are  $\Delta S_V = 6,51 \cdot 10^5 \text{ Jm}^{-3}\text{K}^{-1}$  and  $\sigma_{lc} = 0,115 \text{ Jm}^{-2}$  [8] and obtained resulted from the experimental investigation, Table 2.

Table 2 The volumetric grain density and maximal supercooling obtained from experimental investigation

Plate thicknes / mm	Maximal supercooling / K	Grain density, / m <sup>-3</sup>
10	8,259	1,493·10 <sup>11</sup>
15	7,680	1,235·10 <sup>11</sup>
20	6,876	0,787·10 <sup>11</sup>
30	6,367	0,442·10 <sup>11</sup>

These data allowed determining the nucleation substrate size distribution for the AZ91 / 1 % SiC<sub>p</sub> composite described by equation (7).

$$N(d) = \frac{2,426 \cdot 10^{12}}{d} \cdot \exp\left(-\frac{(\ln(d) - 20,429)^2}{6,308}\right) \quad (7)$$

The final effect of the representation were showed in Figures 3 and 4.

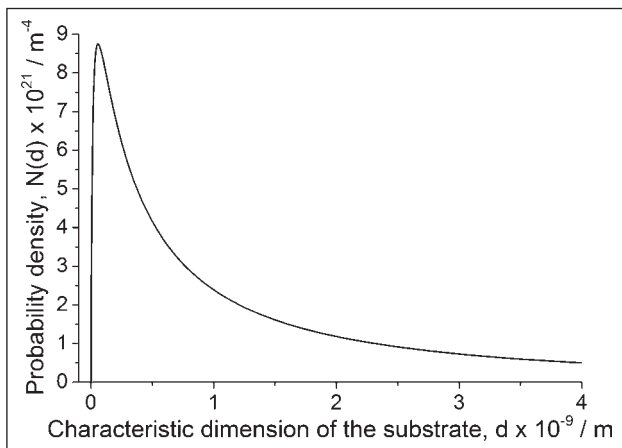

**Figure 3** Diagram of nucleation substrate size distribution for the AZ91 / 1 % SiC<sub>p</sub> composite on the base of equation (7)

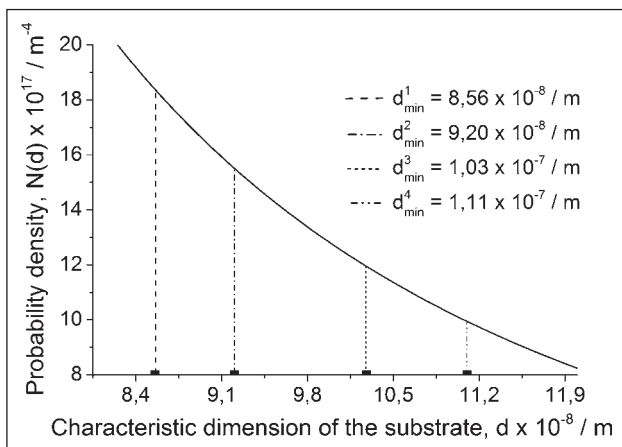

**Figure 4** Diagram of nucleation substrate size distribution for the AZ91 / 1 % SiC<sub>p</sub> composite on the base of equation (7) with minimal substrate dimension for experimental data

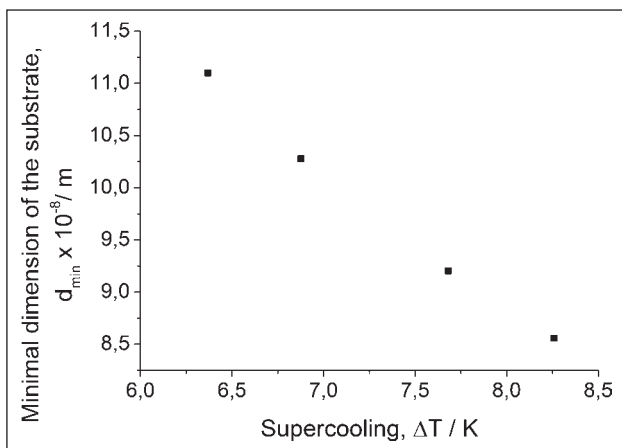

**Figure 5** The minimal dimension of the active substrate as a function of supercooling

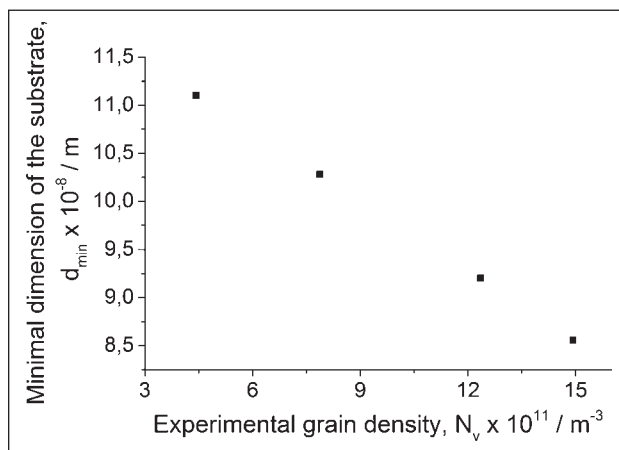

**Figure 6** The minimal dimension of the active substrate as a function of experimental grain density

Basing on the equation (4) the minimal active substrate, which took part in heterogeneous nucleation process, was calculated for different condition (Table 2) and showed as diagram in the Figures 5 and 6.

### CONCLUSIONS

Used algorithm allowed determining the nucleation substrate size distribution for the composite and described by equation (7). Equation (7) and given cooling rate used in the free-growth model allowed to calculate grain density of magnesium primary phase in the AZ91 / 1 % SiC<sub>p</sub>.

Applying the inverse modelling allows not only taking into account active nucleation particles but also to consider the situation when the nucleation occurs on more than one surface of a particle.

### Acknowledgement

The authors acknowledge financial support from the National Science Center grant No. UMO-2011/03/B/ST8/05217 (AGH no. 18.18.170.459).

### REFERENCES

- [1] J. Lelito, P. L. Zak, A. A. Shirzadi, A. L. Greer, W. K. Krajewski, J. S. Suchy, K. Haberl, P. Schumacher, Acta Materialia, 60 (2012), 2950-2958.
- [2] A. L. Greer, A. M. Bunn, A. Tronche, P. V. Evans, D. J. Bristow, Acta Materialia, 48 (2000), 2823-2835.
- [3] T. E. Quested, A. L. Greer, Acta Materialia, 52 (2004), 3859-3868.
- [4] A. Luo, Scripta Metall. Mater., 31 (1994), 1253-1258.
- [5] J. Dańko, R. Dańko, M. Holtzer, Metalurgija, 42 (2003) 3, 173-177.
- [6] R. Dańko, Metalurgija, 50 (2011) 2, 93-96.
- [7] B. Gracz, Wydawnictwo Naukowe AKAPIT (2013), 364-368.
- [8] R. Gunther, Ch. Hartig, R. Bormann, Acta Materialia, 54 (2006), 5591-5597.

**Note:** The responsible translator for English language: “ANGOS” Translation Office, Poland, Kraków.