

University of Nebraska - Lincoln

DigitalCommons@University of Nebraska - Lincoln

Final Reports & Technical Briefs from Mid-America Transportation Center

Mid-America Transportation Center

2010

Safety Investigation and Guidance for Work-Zone Devices in Freight Transportation Systems Subjected to Passenger Car and Truck Impacts with New Crash Standards

Ronald K. Faller Ph.D., P.E.

University of Nebraska - Lincoln, rfaller1@unl.edu

Dean L. Sicking Ph.D., P.E.

University of Nebraska - Lincoln, dsicking1@unl.edu

Karla A. Lechtenberg M.S.C.E., E.I.T.

University of Nebraska - Lincoln, kpolivka2@unl.edu

James C. Holloway M.S.C.E., E.I.T.

University of Nebraska - Lincoln, jholloway1@unl.edu

Jennifer D. Schmidt

University of Nebraska-Lincoln, jennifer.rasmussen@unl.edu

Follow this and additional works at: <https://digitalcommons.unl.edu/matcreports>



Part of the [Civil Engineering Commons](#)

Faller, Ronald K. Ph.D., P.E.; Sicking, Dean L. Ph.D., P.E.; Lechtenberg, Karla A. M.S.C.E., E.I.T.; Holloway, James C. M.S.C.E., E.I.T.; and Schmidt, Jennifer D., "Safety Investigation and Guidance for Work-Zone Devices in Freight Transportation Systems Subjected to Passenger Car and Truck Impacts with New Crash Standards" (2010). *Final Reports & Technical Briefs from Mid-America Transportation Center*. 12. <https://digitalcommons.unl.edu/matcreports/12>

This Article is brought to you for free and open access by the Mid-America Transportation Center at DigitalCommons@University of Nebraska - Lincoln. It has been accepted for inclusion in Final Reports & Technical Briefs from Mid-America Transportation Center by an authorized administrator of DigitalCommons@University of Nebraska - Lincoln.



MID-AMERICA TRANSPORTATION CENTER

Report # MATC-UNL: 100

Final Report



Safety Investigation and Guidance for Work-Zone Devices in Freight Transportation Systems Subjected to Passenger Car and Truck Impacts with New Crash Standards

Ronald K. Faller, Ph.D., P.E.

Research Assistant Professor
Midwest Roadside Safety Facility (MwRSF)
Nebraska Transportation Center
University of Nebraska-Lincoln

Dean L. Sicking, Ph.D., P.E.

Karla A. Lechtenberg, M.S.M.E., E.I.T.

James C. Holloway, M.S.C.E., E.I.T.

Jennifer D. Schmidt, M.S.C.E., E.I.T.



2010

A Cooperative Research Project sponsored by the
U.S. Department of Transportation Research and
Innovative Technology Administration

The contents of this report reflect the views of the authors, who are responsible for the facts and the accuracy of the information presented herein. This document is disseminated under the sponsorship of the Department of Transportation University Transportation Centers Program, in the interest of information exchange.
The U.S. Government assumes no liability for the contents or use thereof.

MATC



TESTING CERT # 2937.01

Safety Investigation and Guidance for Work-Zone Devices in Freight Transportation Systems Subjected to Passenger Car and Truck Impacts with New Crash Standards

Submitted by:

Jennifer D. Schmidt, M.S.C.E., E.I.T.
Graduate Research Assistant

Ronald K. Faller, Ph.D., P.E.
Research Assistant Professor

Karla A. Lechtenberg, M.S.M.E., E.I.T.
Research Associate Engineer

Dean L. Sicking, Ph.D., P.E.
Professor and MwRSF Director

James C. Holloway, M.S.C.E., E.I.T.
Test Site Manager

Midwest Roadside Safety Facility
Nebraska Transportation Center
University of Nebraska-Lincoln
130 Whittier Building
2200 Vine St.
Lincoln, Nebraska 68583-0853
(402) 472-0965

Submitted to

Mid-America Transportation Center
U.S. Department of Transportation
Region VII University Transportation Center
University of Nebraska-Lincoln
2200 Vine St.
Lincoln, Nebraska 68583-0152

Smart Work Zone Deployment Initiative
Center for Transportation Research Education
Iowa State University
2711 S. Loop Drive, Suite 4700
Ames, Iowa 50010-8664

MwRSF Research Report No. TRP-03-225-10
March 1, 2010

TECHNICAL REPORT DOCUMENTATION PAGE

1. Report No. TRP-03-225-10	2.	3. Recipient's Accession No.	
4. Title and Subtitle Safety Investigation and Guidance for Work-Zone Devices in Freight Transportation Systems Subjected to Passenger Car and Truck Impacts with New Crash Standards		5. Report Date March 1, 2010	
7. Author(s) Schmidt, J.D., Faller, R.K., Lechtenberg, K.A., Sicking, D.L., Holloway, J.C.		8. Performing Organization Report No. TRP-03-225-10	
9. Performing Organization Name and Address Midwest Roadside Safety Facility (MwRSF) Nebraska Transportation Center University of Nebraska-Lincoln 130 Whittier Building, 2200 Vine St. Lincoln, Nebraska 68583-0853		10. Project/Task/Work Unit No.	
12. Sponsoring Organization Name and Address Mid-America Transportation Center U.S. Department of Transportation Region VII University Transportation Center University of Nebraska-Lincoln 2200 Vine St. Lincoln, Nebraska 68583-0152 Smart Work Zone Deployment Initiative Center for Transportation Research Education Iowa State University 2711 S. Loop Drive, Suite 4700 Ames, Iowa 50010-8664		11. Contract © or Grant (G) No.	
15. Supplementary Notes Prepared in cooperation with U.S. Department of Transportation, Federal Highway Administration.		13. Type of Report and Period Covered Draft Report: 2008 – 2010	
16. Abstract (Limit: 200 words) Crashworthy, work-zone, portable sign support systems accepted under NCHRP Report No. 350 were analyzed to predict their safety performance according to the TL-3 MASH evaluation criteria. An analysis was conducted to determine which hardware parameters of sign support systems would likely contribute to the safety performance with MASH. The accuracy of the method was evaluated through full-scale crash testing. Four full-scale crash tests were conducted with a pickup truck. Two tall-mounted, sign support systems with aluminum sign panels failed the MASH criteria due to windshield penetration. One low-mounted system with a vinyl, roll-up sign panel failed the MASH criteria due to windshield and floorboard penetration. Another low-mounted system with an aluminum sign panel successfully met the MASH criteria. Four full-scale crash tests were conducted with a small passenger car. The low-mounted tripod system with an aluminum sign panel failed the MASH criteria due to windshield penetration. One low-mounted system with aluminum sign panel failed the MASH criteria due to excessive windshield deformation, and another similar system passed the MASH criteria. The low-mounted system with a vinyl, roll-up sign panel successfully met the MASH criteria. Hardware parameters of work-zone sign support systems that were determined to be important for failure with MASH include sign panel material, the height to the top of the mast, the presence of flags, sign-locking mechanism, base layout and system orientation. Flowcharts were provided to assist manufacturers when designing new sign support systems.		14. Sponsoring Agency Code SWZDI Contract No. 11533 MATC TRB RiP No. 17141	
17. Document Analysis/Descriptors Highway Safety, Crash Test, Compliance Test, MASH, Work-Zone Device, and Temporary Sign Stand		18. Availability Statement No restrictions. Document available from: National Technical Information Services, Springfield, Virginia 22161	
19. Security Class (this report) Unclassified	20. Security Class (this page) Unclassified	21. No. of Pages 377	22. Price

Disclaimer Statement

This report was funded in part through grant(s) from Dicke Safety Products, the Federal Highway Administration, U.S. Department of Transportation, the Mid-America Transportation Center, and the Smart Work Zone Deployment Initiative at the Center for Transportation Research Education, Iowa State University. The contents of this report reflect the views and opinions of the authors who are responsible for the facts and the accuracy of the data presented herein. The contents do not necessarily reflect the official views or policies of the Mid-America Transportation Center, the Center for Transportation Research Education, Dicke Safety Products, nor the Federal Highway Administration, or the U.S. Department of Transportation. This report does not constitute a standard, specification, regulation, product endorsement, or an endorsement of manufacturers.

Uncertainty of Measurement Statement

The Midwest Roadside Safety Facility (MwRSF) has determined the uncertainty of measurements for several parameters involved in standard full-scale crash testing and non-standard testing of roadside safety features. Information regarding the uncertainty of measurements for critical parameters is available upon request by the sponsor and the Federal Highway Administration.

Independent Approving Authority

The Independent Approving Authority (IAA) for this project was Ms. Karla A. Lechtenberg, Research Associate Engineer, of the Midwest Roadside Safety Facility, University of Nebraska Lincoln.

Acknowledgements

The authors wish to acknowledge several sources that made a contribution to this project: (1) the Mid-America Transportation Center, the Smart Work Zone Deployment Initiative at the Center for Transportation Research Education, Dicke Safety Products, and the U.S. Department of Transportation for sponsoring this project and (2) MwRSF personnel for conducting the crash tests.

Acknowledgement is also given to the following individuals who made a contribution towards the completion of this research project.

Midwest Roadside Safety Facility

J.D. Reid, Ph.D., Professor
R.W. Bielenberg, M.S.M.E., E.I.T., Research Associate Engineer
S.K. Rosenbaugh, M.S.C.E., E.I.T., Research Associate Engineer
C.L. Meyer, B.S.M.E., E.I.T., Research Associate Engineer
A.T. Russell, B.S.B.A., Shop Manager
K.L. Krenk, B.S.M.A, Maintenance Mechanic
A.T. McMaster, Laboratory Mechanic
Undergraduate and Graduate Research Assistants

Mid-America Transportation Center

Laurence Rilett, Ph.D., P.E., Professor and MATC Director

Center for Transportation Research Education – Iowa State University

Thomas J. McDonald, Program Manager, Smart Work Zone Deployment Initiative (SWZDI)

Federal Highway Administration

Nicholas Artimovich, II, Highway Safety Engineer, Office of Safety Design
Matt Lupes, P.E., Highway Safety Engineer, Office of Safety Design

Iowa Department of Transportation

Daniel Sprengler, Traffic Control Engineer

Nebraska Department of Roads

Matt Neemann, Traffic Control Engineer

TABLE OF CONTENTS

TECHNICAL REPORT DOCUMENTATION PAGE i

DISCLAIMER STATEMENT ii

UNCERTAINTY OF MEASUREMENT STATEMENT ii

INDEPENDENT APPROVING AUTHORITY ii

ACKNOWLEDGEMENTS iii

TABLE OF CONTENTS iv

LIST OF FIGURES vii

LIST OF TABLES xii

1 INTRODUCTION 1

 1.1 Problem Statement 1

 1.2 Research Objectives 2

 1.3 Scope 3

2 LITERATURE REVIEW 4

 2.1 Background 4

 2.2 NCHRP Report No. 350 Work-Zone Testing 7

 2.2.1 Full-Scale Tests 7

 2.3 MASH Testing of Permanent Sign Support Systems 47

3 RESEARCH APPROACH 48

4 CRASH DATA 50

 4.1 Parameter Analysis 59

 4.1.1 Initial Analysis 61

 4.1.2 Final Analysis 62

 4.2 System Analysis 63

 4.3 System Selection 68

5 WORK-ZONE SIGN SUPPORT SYSTEMS 70

 5.1 Portable Sign Support Systems 72

6 TEST REQUIREMENTS AND EVALUATION CRITERIA 93

 6.1 Test Requirements 93

 6.2 Evaluation Criteria 94

7 TEST CONDITIONS 97

 7.1 Test Facility 97

7.2 Vehicle Tow and Guidance System	97
7.3 Test Vehicles	97
7.4 Simulated Occupant	112
7.5 Data Acquisition Systems	112
7.5.1 Accelerometers	112
7.5.2 Rate Transducers	113
7.5.3 Pressure Tape Switches	114
7.5.4 High-Speed Photography	114
8 FULL-SCALE CRASH TEST NO. WZ09-1 (SYSTEM NOS. 1A AND 1B)	120
8.1 Test No. WZ09-1	120
8.2 Weather Conditions	120
8.3 Test Description	120
8.4 System and Component Damage	122
8.5 Vehicle Damage	123
8.6 Occupant Risk	124
8.7 Discussion	124
9 FULL-SCALE CRASH TEST NO. WZ09-2 (SYSTEM NOS. 2A AND 2B)	139
9.1 Test No. WZ09-2	139
9.2 Weather Conditions	139
9.3 Test Description	139
9.4 System and Component Damage	141
9.5 Vehicle Damage	142
9.6 Occupant Risk	143
9.7 Discussion	143
10 FULL-SCALE CRASH TEST NO. WZ09-3 (SYSTEM NOS. 3A AND 3B)	159
10.1 Test No. WZ09-3	159
10.2 Weather Conditions	159
10.3 Test Description	159
10.4 System and Component Damage	161
10.5 Vehicle Damage	162
10.6 Occupant Risk	163
10.7 Discussion	163
11 FULL-SCALE CRASH TEST NO. WZ09-4 (SYSTEM NOS. 4A AND 4B)	180
11.1 Test No. WZ09-4	180
11.2 Weather Conditions	180
11.3 Test Description	180
11.4 System and Component Damage	182
11.5 Vehicle Damage	183
11.6 Occupant Risk	183
11.7 Discussion	184
12 DISCUSSION	199
12.1 Importance of System Parameters	204

13 COMPUTER SIMULATION213

- 13.1 Introduction.....213
- 13.2 Sign Support System Model214
- 13.3 Initial Simulation219
 - 13.3.1 Results.....219
- 13.4 Full-Scale Simulation.....219
 - 13.4.1 Model Validation220
 - 13.4.2 Results.....220
- 13.5 Conclusions.....227

14 SUMMARY, CONCLUSIONS, AND RECOMMENDATIONS230

15 REFERENCES243

16 APPENDICES247

- Appendix A. Analysis Spreadsheets.....248
- Appendix B. Material Specifications259
- Appendix C. Dimensional Measurements of Portable Sign Supports.....264
- Appendix D. Vehicle Center of Gravity Determination.....278
- Appendix E. Vehicle Deformation Records.....283
- Appendix F. Accelerometer and Rate Transducer Plots, Test No. WZ09-1.....293
- Appendix G. Accelerometer and Rate Transducer Plots, Test No. WZ09-2.....308
- Appendix H. Accelerometer and Rate Transducer Plots, Test No. WZ09-3.....335
- Appendix I. Accelerometer and Rate Transducer Plots, Test No. WZ09-4.....362

LIST OF FIGURES

Figure 1. Existing Work-Zone Traffic Control Devices in Simulated Truck Bogie Testing	6
Figure 2. Features of a Typical Work-Zone Sign Support System.....	8
Figure 3. Historical Tests of Low-Mounted Sign Support Systems	45
Figure 4. Historical Tests of High-Mounted Sign Support Systems	45
Figure 5. TL-3 MASH Impact Prediction with Pickup Truck – X-footprint Base	64
Figure 6. TL-3 MASH Impact Prediction with Pickup Truck – Parallel Dual Uprights	65
Figure 7. TL-3 MASH Impact Prediction with Small Car – X-footprint Base.....	66
Figure 8. TL-3 MASH Impact Prediction with Small Car – Parallel Dual Uprights.....	67
Figure 9. Test Layout, Test No. WZ09-1.....	73
Figure 10. Test Layout, Test No. WZ09-2.....	74
Figure 11. Test Layout, Test No. WZ09-3.....	75
Figure 12. Test Layout, Test No. WZ09-4.....	76
Figure 13. System No. 1A Details, Test No. WZ09-1	77
Figure 14. System No. 1A Details, Test No. WZ09-1	78
Figure 15. System No. 1B Details, Test No. WZ09-1	79
Figure 16. System No. 1B Details, Test No. WZ09-1	80
Figure 17. System No. 2A Details, Test No. WZ09-2.....	81
Figure 18. System No. 2A Details, Test No. WZ09-2.....	82
Figure 19. System No. 2B Details, Test No. WZ09-2.....	83
Figure 20. System No. 2B Details, Test No. WZ09-2.....	84
Figure 21. System No. 3A Details, Test No. WZ09-3.....	85
Figure 22. System No. 3A Details, Test No. WZ09-3.....	86
Figure 23. System No. 3B Details, Test No. WZ09-3.....	87
Figure 24. System No. 3B Details, Test No. WZ09-3.....	88
Figure 25. System No. 4A Details, Test No. WZ09-4.....	89
Figure 26. System No. 4A Details, Test No. WZ09-4.....	90
Figure 27. System No. 4B Details, Test No. WZ09-4.....	91
Figure 28. System No. 4B Details, Test No. WZ09-4.....	92
Figure 29. Test Vehicle, Test No. WZ09-1	98
Figure 30. Vehicle Dimensions, Test No. WZ09-1	99
Figure 31. Test Vehicle, Test No. WZ09-2	101
Figure 32. Vehicle Dimensions, Test No. WZ09-2	102
Figure 33. Test Vehicle, Test No. WZ09-3	103
Figure 34. Vehicle Dimensions, Test No. WZ09-3	104
Figure 35. Test Vehicle, Test No. WZ09-4	105
Figure 36. Vehicle Dimensions, Test No. WZ09-4	106
Figure 37. Target Geometry, Test No. WZ09-1	108
Figure 38. Target Geometry, Test No. WZ09-2	109
Figure 39. Target Geometry, Test No. WZ09-3	110
Figure 40. Target Geometry, Test No. WZ09-4	111
Figure 41. Camera Locations, Speeds, and Lens Settings, Test No. WZ09-1.....	116
Figure 42. Camera Locations, Speeds, and Lens Settings, Test No. WZ09-2.....	117
Figure 43. Camera Locations, Speeds, and Lens Settings, Test No. WZ09-3.....	118
Figure 44. Camera Locations, Speeds, and Lens Settings, Test No. WZ09-4.....	119

Figure 45. Summary of Test Results and Sequential Photographs, Test No. WZ09-1A.....125
Figure 46. Summary of Test Results and Sequential Photographs, Test No. WZ09-1B126
Figure 47. Additional Sequential Photographs, Test No. WZ09-1A127
Figure 48. Additional Sequential Photographs, Test No. WZ09-1B128
Figure 49. Documentary Photographs, Test No. WZ09-1129
Figure 50. Impact Location, Test No. WZ09-1A.....130
Figure 51. Impact Location, Test No. WZ09-1B.....131
Figure 52. Vehicle Final Position and Trajectory Marks, Test No. WZ09-1132
Figure 53. System Damage, Test No. WZ09-1A.....133
Figure 54. System Damage, Test No. WZ09-1A.....134
Figure 55. System Damage, Test No. WZ09-1B135
Figure 56. System Damage, Test No. WZ09-1B136
Figure 57. Vehicle Damage, Test No. WZ09-1137
Figure 58. Vehicle Damage, Test No. WZ09-1138
Figure 59. Summary of Test Results and Sequential Photographs, Test No. WZ09-2A.....145
Figure 60. Summary of Test Results and Sequential Photographs, Test No. WZ09-2B146
Figure 61. Additional Sequential Photographs, Test No. WZ09-2A147
Figure 62. Additional Sequential Photographs, Test No. WZ09-2B148
Figure 63. Documentary Photographs, Test No. WZ09-2149
Figure 64. Impact Location, Test No. WZ09-2A.....150
Figure 65. Impact Location, Test No. WZ09-2B.....151
Figure 66. Vehicle Final Position and Trajectory Marks, Test No. WZ09-2152
Figure 67. System Damage, Test No. WZ09-2A.....153
Figure 68. System Damage, Test No. WZ09-2A.....154
Figure 69. System Damage, Test No. WZ09-2B155
Figure 70. System Damage, Test No. WZ09-2B156
Figure 71. Vehicle Damage, Test No. WZ09-2157
Figure 72. Vehicle Damage, Test No. WZ09-2158
Figure 73. Summary of Test Results and Sequential Photographs, Test No. WZ09-3A.....165
Figure 74. Summary of Test Results and Sequential Photographs, Test No. WZ09-3B166
Figure 75. Additional Sequential Photographs, Test No. WZ09-3.....167
Figure 76. Additional Sequential Photographs, Test No. WZ09-3.....168
Figure 77. Additional Sequential Photographs, Test No. WZ09-3A169
Figure 78. Documentary Photographs, Test No. WZ09-3170
Figure 79. Impact Location, Test No. WZ09-3A.....171
Figure 80. Impact Location, Test No. WZ09-3B.....172
Figure 81. Vehicle Final Position and Trajectory Marks, Test No. WZ09-3173
Figure 82. System Damage, Test No. WZ09-3A.....174
Figure 83. System Damage, Test No. WZ09-3A.....175
Figure 84. System Damage, Test No. WZ09-3B176
Figure 85. System Damage, Test No. WZ09-3B177
Figure 86. Vehicle Damage, Test No. WZ09-3178
Figure 87. Vehicle Damage, Test No. WZ09-3179
Figure 88. Summary of Test Results and Sequential Photographs, Test No. WZ09-4A.....185
Figure 89. Summary of Test Results and Sequential Photographs, Test No. WZ09-4B.....186
Figure 90. Additional Sequential Photographs, Test No. WZ09-4.....187

Figure 91. Additional Sequential Photographs, Test No. WZ09-4B	188
Figure 92. Documentary Photographs, Test No. WZ09-4	189
Figure 93. Impact Location, Test No. WZ09-4A.....	190
Figure 94. Impact Location, Test No. WZ09-4B.....	191
Figure 95. Vehicle Final Position and Trajectory Marks, Test No. WZ09-4	192
Figure 96. System Damage, Test No. WZ09-4A.....	193
Figure 97. System Damage, Test No. WZ09-4A.....	194
Figure 98. System Damage, Test No. WZ09-4B	195
Figure 99. System Damage, Test No. WZ09-4B	196
Figure 100. Vehicle Damage, Test No. WZ09-4	197
Figure 101. Vehicle Damage, Test No. WZ09-4	198
Figure 102. System No. 4A, X-Footprint Base Floorboard Penetration.....	200
Figure 103. System No. 3A, Frangible Mast	200
Figure 104. System No. 1B, Base-Bending Mast	201
Figure 105. System No. 2B, Tripod Oriented at 90 Degrees	202
Figure 106. System No. 1A, Flag Holder Penetrating the Roof	203
Figure 107. System No. WZ09-2A and the Finite Element Model	215
Figure 108. Mesh Detail at Base and Enlarged View of Breakaway Holes	216
Figure 109. Steel Stress – Strain Curve	217
Figure 110. Comparison of Full-Scale Crash Test and Simulation Results	221
Figure 111. Comparison of Full-Scale Crash Test and Simulation Result	222
Figure 112. Velocity of Mast vs. Time	223
Figure 113. Contact Force between Sign Panel and Windshield.....	224
Figure 114. Energy vs. Time.....	225
Figure 115. Longitudinal Velocity vs. Time.....	225
Figure 116. Internal Energy and Hourglass Energy vs. Time.....	226
Figure 117. Windshield Deformation	227
Figure 118. Windshield Deformation vs. Time	227
Figure 119. TL-3 MASH Impact Prediction with Pickup Truck – X-Footprint Base	239
Figure B-1. System No. 1B Sign Panel.....	260
Figure B-2. System No. 1B Legs Square Tubing	261
Figure B-3. System No. 1B Mast Square Tubing	262
Figure B-4. System No. 1B Outer Sleeve Square Tubing	263
Figure D-1. Vehicle Mass Distribution, Test No. WZ09-1	279
Figure D-2. Vehicle Mass Distribution, Test No. WZ09-2	280
Figure D-3. Vehicle Mass Distribution, Test No. WZ09-3	281
Figure D-4. Vehicle Mass Distribution, Test No. WZ09-4	282
Figure E-1. Roof Deformation Data, Test No. WZ09-1	284
Figure E-2. Windshield Deformation Data, Test No. WZ09-1.....	285
Figure E-3. Roof Deformation Data, Test No. WZ09-2	286
Figure E-4. Windshield Deformation Data, Test No. WZ09-2.....	287
Figure E-5. Roof Deformation Data Set 1, Test No. WZ09-3.....	288
Figure E-6. Roof Deformation Data Set 2, Test No. WZ09-3.....	289
Figure E-7. Windshield Deformation Data, Test No. WZ09-3.....	290
Figure E-8. Roof Deformation Data Set 1, Test No. WZ09-4.....	291
Figure E-9. Roof Deformation Data Set 2, Test No. WZ09-4.....	292

Figure F-1. 10-ms Average Longitudinal Deceleration (EDR-4), Test No. WZ09-1A.....294
Figure F-2. Longitudinal Occupant Impact Velocity (EDR-4), Test No. WZ09-1A295
Figure F-3. Longitudinal Occupant Displacement (EDR-4), Test No. WZ09-1A296
Figure F-4. 10-ms Average Lateral Deceleration (EDR-4), Test No. WZ09-1A.....297
Figure F-5. Lateral Occupant Impact Velocity (EDR-4), Test No. WZ09-1A.....298
Figure F-6. Lateral Occupant Displacement (EDR-4), Test No. WZ09-1A.....299
Figure F-7. Vehicle Angular Displacements (EDR-4), Test No. WZ09-1A300
Figure F-8. 10-ms Average Longitudinal Deceleration (EDR-4), Test No. WZ09-1B.....301
Figure F-9. Longitudinal Occupant Impact Velocity (EDR-4), Test No. WZ09-1B.....302
Figure F-10. Longitudinal Occupant Displacement (EDR-4), Test No. WZ09-1B.....303
Figure F-11. 10-ms Average Lateral Deceleration (EDR-4), Test No. WZ09-1B304
Figure F-12. Lateral Occupant Impact Velocity (EDR-4), Test No. WZ09-1B305
Figure F-13. Lateral Occupant Displacement (EDR-4), Test No. WZ09-1B306
Figure F-14. Vehicle Angular Displacements (EDR-4), Test No. WZ09-1B307
Figure G-1. 10-ms Average Longitudinal Deceleration (EDR-3), Test No. WZ09-2A.....309
Figure G-2. Longitudinal Occupant Impact Velocity (EDR-3), Test No. WZ09-2A.....310
Figure G-3. Longitudinal Occupant Displacement (EDR-3), Test No. WZ09-2A.....311
Figure G-4. 10-ms Average Lateral Deceleration (EDR-3), Test No. WZ09-2A312
Figure G-5. Lateral Occupant Impact Velocity (EDR-3), Test No. WZ09-2A313
Figure G-6. Lateral Occupant Displacement (EDR-3), Test No. WZ09-2A314
Figure G-7. 10-ms Average Longitudinal Deceleration (DTS), Test No. WZ09-2A.....315
Figure G-8. Longitudinal Occupant Impact Velocity (DTS), Test No. WZ09-2A.....316
Figure G-9. Longitudinal Occupant Displacement (DTS), Test No. WZ09-2A317
Figure G-10. 10-ms Average Lateral Deceleration (DTS), Test No. WZ09-2A318
Figure G-11. Lateral Occupant Impact Velocity (DTS), Test No. WZ09-2A.....319
Figure G-12. Lateral Occupant Displacement (DTS), Test No. WZ09-2A.....320
Figure G-13. Vehicle Angular Displacements (DTS), Test No. WZ09-2A321
Figure G-14. 10-ms Average Longitudinal Deceleration (EDR-3), Test No. WZ09-2B322
Figure G-15. Longitudinal Occupant Impact Velocity (EDR-3), Test No. WZ09-2B323
Figure G-16. Longitudinal Occupant Displacement (EDR-3), Test No. WZ09-2B324
Figure G-17. 10-ms Average Lateral Deceleration (EDR-3), Test No. WZ09-2B.....325
Figure G-18. Lateral Occupant Impact Velocity (EDR-3), Test No. WZ09-2B326
Figure G-19. Lateral Occupant Displacement (EDR-3), Test No. WZ09-2B327
Figure G-20. 10-ms Average Longitudinal Deceleration (DTS), Test No. WZ09-2B328
Figure G-21. Longitudinal Occupant Impact Velocity (DTS), Test No. WZ09-2B.....329
Figure G-22. Longitudinal Occupant Displacement (DTS), Test No. WZ09-2B.....330
Figure G-23. 10-ms Average Lateral Deceleration (DTS), Test No. WZ09-2B331
Figure G-24. Lateral Occupant Impact Velocity (DTS), Test No. WZ09-2B332
Figure G-25. Lateral Occupant Displacement (DTS), Test No. WZ09-2B333
Figure G-26. Vehicle Angular Displacements (DTS), Test No. WZ09-2B.....334
Figure H-1. 10-ms Average Longitudinal Deceleration (EDR-3), Test No. WZ09-3A.....336
Figure H-2. Longitudinal Occupant Impact Velocity (EDR-3), Test No. WZ09-3A.....337
Figure H-3. Longitudinal Occupant Displacement (EDR-3), Test No. WZ09-3A.....338
Figure H-4. 10-ms Average Lateral Deceleration (EDR-3), Test No. WZ09-3A339
Figure H-5. Lateral Occupant Impact Velocity (EDR-3), Test No. WZ09-3A340
Figure H-6. Lateral Occupant Displacement (EDR-3), Test No. WZ09-3A341

Figure H-7. 10-ms Average Longitudinal Deceleration (DTS), Test No. WZ09-3A.....342
Figure H-8. Longitudinal Occupant Impact Velocity (DTS), Test No. WZ09-3A.....343
Figure H-9. Longitudinal Occupant Displacement (DTS), Test No. WZ09-3A344
Figure H-10. 10-ms Average Lateral Deceleration (DTS), Test No. WZ09-3A345
Figure H-11. Lateral Occupant Impact Velocity (DTS), Test No. WZ09-3A346
Figure H-12. Lateral Occupant Displacement (DTS), Test No. WZ09-3A.....347
Figure H-13. Vehicle Angular Displacements (DTS), Test No. WZ09-3A348
Figure H-14. 10-ms Average Longitudinal Deceleration (EDR-3), Test No. WZ09-3B349
Figure H-15. Longitudinal Occupant Impact Velocity (EDR-3), Test No. WZ09-3B350
Figure H-16. Longitudinal Occupant Displacement (EDR-3), Test No. WZ09-3B351
Figure H-17. 10-ms Average Lateral Deceleration (EDR-3), Test No. WZ09-3B.....352
Figure H-18. Lateral Occupant Impact Velocity (EDR-3), Test No. WZ09-3B353
Figure H-19. Lateral Occupant Displacement (EDR-3), Test No. WZ09-3B354
Figure H-20. 10-ms Average Longitudinal Deceleration (DTS), Test No. WZ09-3B355
Figure H-21. Longitudinal Occupant Impact Velocity (DTS), Test No. WZ09-3B.....356
Figure H-22. Longitudinal Occupant Displacement (DTS), Test No. WZ09-3B.....357
Figure H-23. 10-ms Average Lateral Deceleration (DTS), Test No. WZ09-3B358
Figure H-24. Lateral Occupant Impact Velocity (DTS), Test No. WZ09-3B359
Figure H-25. Lateral Occupant Displacement (DTS), Test No. WZ09-3B360
Figure H-26. Vehicle Angular Displacements (DTS), Test No. WZ09-3B.....361
Figure I-1. 10-ms Average Longitudinal Deceleration (EDR-3), Test No. WZ09-4A.....363
Figure I-2. Longitudinal Occupant Impact Velocity (EDR-3), Test No. WZ09-4A364
Figure I-3. Longitudinal Occupant Displacement (EDR-3), Test No. WZ09-4A365
Figure I-4. 10-ms Average Lateral Deceleration (EDR-3), Test No. WZ09-4A.....366
Figure I-5. Lateral Occupant Impact Velocity (EDR-3), Test No. WZ09-4A.....367
Figure I-6. Lateral Occupant Displacement (EDR-3), Test No. WZ09-4A.....368
Figure I-7. Vehicle Angular Displacements (DTS), Test No. WZ09-4A.....369
Figure I-8. 10-ms Average Longitudinal Deceleration (EDR-3), Test No. WZ09-4B.....370
Figure I-9. Longitudinal Occupant Impact Velocity (EDR-3), Test No. WZ09-4B.....371
Figure I-10. Longitudinal Occupant Displacement (EDR-3), Test No. WZ09-4B372
Figure I-11. 10-ms Average Lateral Deceleration (EDR-3), Test No. WZ09-4B373
Figure I-12. Lateral Occupant Impact Velocity (EDR-3), Test No. WZ09-4B374
Figure I-13. Lateral Occupant Displacement (EDR-3), Test No. WZ09-4B.....375
Figure I-14. Vehicle Angular Displacements (DTS), Test No. WZ09-4B376

LIST OF TABLES

Table 1. Work-Zone Sign Support Systems Design Variations	10
Table 2. Prior Full Scale Crash Testing System Details.....	12
Table 3. Actual and Predicted Performance Methods of Failure.....	51
Table 4. Important Vehicle Dimensions	52
Table 5. Predicted Chance of Failing MASH.....	53
Table 6. System Predictions.....	54
Table 7. Predicted Chance of System Failures by Parameter	60
Table 8. Recommended Portable Sign Support Systems for Testing	69
Table 9. List of Crash Tests	72
Table 10. MASH TL-3 Crash Test Conditions.....	94
Table 11. MASH Evaluation Criteria for Traffic Control Devices	95
Table 12. MASH Failure Criteria	96
Table 13. Weather Conditions, Test No. WZ09-1	120
Table 14. Sequential Description of Impact Events, Test No. WZ09-1A	121
Table 15. Sequential Description of Impact Events, Test No. WZ09-1B.....	122
Table 16. Weather Conditions, Test No. WZ09-2	139
Table 17. Sequential Description of Impact Events, Test No. WZ09-2A	140
Table 18. Sequential Description of Impact Events, Test No. WZ09-2B.....	141
Table 19. Weather Conditions, Test No. WZ09-3	159
Table 20. Sequential Description of Impact Events, Test No. WZ09-3A	160
Table 21. Sequential Description of Impact Events, Test No. WZ09-3B.....	161
Table 22. Summary of OIV, ORA, THIV, and PHD Values, Test No. WZ09-3	163
Table 23. Weather Conditions, Test No. WZ09-4.....	180
Table 24. Sequential Description of Impact Events, Test No. WZ09-4A	181
Table 25. Sequential Description of Impact Events, Test No. WZ09-4B.....	182
Table 26. Summary of Sign System Parts	218
Table 27. Summary of Safety Performance Evaluation Results, Test No. WZ09-1	231
Table 28. Summary of Safety Performance Evaluation Results, Test No. WZ09-2	232
Table 29. Summary of Safety Performance Evaluation Results, Test No. WZ09-3	233
Table 30. Summary of Safety Performance Evaluation Results, Test No. WZ09-4	234
Table 31. Parameters Deemed Critical for Potential System Failure	237
Table A-1. Predicted Chance of Failure for Sign Testing with Pickup Truck.....	249
Table A-2. Predicted Chance of Failure for Sign Testing with Small Car	254
Table C-1. Portable Sign Support System Dimensional Measurements.....	265
Table C-2. Portable Sign Support System Dimensional Measurements.....	266
Table C-3. Portable Sign Support System Dimensional Measurements.....	267
Table C-4. Portable Sign Support System Dimensional Measurements.....	268
Table C-5. Portable Sign Support System Dimensional Measurements.....	269
Table C-6. Portable Sign Support System Dimensional Measurements.....	270
Table C-7. Portable Sign Support System Dimensional Measurements.....	271
Table C-8. Portable Sign Support System Dimensional Measurements.....	272
Table C-9. Portable Sign Support System Dimensional Measurements.....	273
Table C-10. Portable Sign Support System Dimensional Measurements.....	274
Table C-11. Portable Sign Support System Dimensional Measurements.....	275

Table C-12. Tripod Portable Sign Support System Dimensional Measurements.....275
Table C-13. Tripod Portable Sign Support System Dimensional Measurements.....276
Table C-14. Tripod Portable Sign Support System Dimensional Measurements.....276
Table C-15. Tripod Portable Sign Support System Dimensional Measurements.....276
Table C-16. Tripod Portable Sign Support System Dimensional Measurements.....277
Table C-17. Tripod Portable Sign Support System Dimensional Measurements.....277
Table C-18. Tripod Portable Sign Support System Dimensional Measurements.....277

1 INTRODUCTION

1.1 Problem Statement

A wide variety of traffic control devices, such as plastic drums, barricades, portable sign support systems, and rigid panel sign supports, are used in work zones. These devices are used to enhance the safety of the work zones by controlling the traffic through these hazardous areas. Unfortunately, the devices themselves may be potentially hazardous to occupants of errant vehicles. Thus, the Federal Highway Administration (FHWA) and the *Manual on Uniform Traffic Control Devices (MUTCD)* [1] require that work-zone traffic control devices must demonstrate acceptable crashworthiness in order to be used on the National Highway System (NHS).

The National Cooperative Highway Research Program (NCHRP) Report No. 350, *Recommended Procedures for the Safety Performance Evaluation of Highway Features* [2] set forth the first guidelines for the safety performance of work-zone traffic control devices. This document recommended that work-zone traffic control devices should be subjected to two full-scale crash tests with a small passenger car. From 1998 through the present, full-scale crash testing on work-zone traffic control devices, such as plastic drums, barricades, portable sign support systems, and rigid panel sign support systems, have been conducted at the University of Nebraska-Lincoln [3-26]. Many of these devices have been accepted by the FHWA as crashworthy devices. If a device shows a propensity to penetrate into the occupant compartment, NCHRP Report No. 350 recommended that an additional crash test should be conducted with a pickup truck. Even though penetration into the occupant compartment was the primary concern for virtually all temporary sign support systems, the FHWA has not required crash testing with a pickup truck for any work-zone traffic control devices.

The American Association of State Highway and Transportation Officials (AASHTO) has published the *Manual for Assessing Safety Hardware* (MASH) [27], which replaced NCHRP Report No. 350 as the new safety performance guidelines used for crash testing and evaluating roadside safety devices. MASH requires that all new work-zone traffic control devices be crash tested with both a small car and a full-size pickup truck. Work-zone sign support systems have been specifically developed to meet NCHRP Report No. 350 safety evaluation guidelines for the 1,808-lb (820-kg) small car impact condition. Therefore, certain parameters of current crashworthy sign support systems may cause these devices to have an unacceptable safety performance when impacted with larger vehicles. Most of the temporary sign support systems approved under NCHRP Report No. 350 were designed to bridge the windshield and strike the roof for taller systems or to breakaway and pass over the top of the car without contacting the windshield. However, this behavior is dependent upon the front-end profile of the 1,808-lb (820-kg) small car. Vehicles with longer or taller front-end profiles could allow the sign system to contact the windshield and produce undesirable behavior. Therefore, the devices found in work zones along the NHS may not be crashworthy with many vehicles larger than the 1,808-lb (820-kg) small car. As a result, additional research was needed to determine the magnitude of this potential safety problem.

1.2 Research Objectives

One of the research objectives for this study was to evaluate the safety performance of selected, crashworthy, portable sign support systems approved under NCHRP Report No. 350 to determine whether these systems are likely to meet the MASH safety performance criteria. A further objective of the study was to develop general guidelines for determining which design

characteristics produce an increased risk for penetrating the occupant compartment on a wide range of passenger vehicles.

1.3 Scope

The research effort began with an analytical study of prior full-scale and bogie vehicle crash tests of work-zone, portable sign support systems. These crash tests were categorized by their predicted methods of failure under MASH by comparing observed sign and mast trajectories from tests with small cars to other vehicle geometries. The accuracy of this method was evaluated by selecting sign systems with a high propensity for failure with full-scale crash testing. Two full-scale crash tests were performed with a small car sedan, while two crash tests were performed with a pickup truck. For each crash test, two portable sign support systems were impacted within each test run, thus resulting in the evaluation of eight systems. The test results were then compared to predicted behavior and, when necessary, the predictions were revised. Recommendations were then made that should help manufacturers to design and highway engineers to select work-zone sign support systems that are likely to provide safe impact performance for a wide range of passenger vehicles.

2 LITERATURE REVIEW

2.1 Background

NCHRP Report No. 350 [2] set forth the first guidelines for the safety performance of work-zone traffic control devices. This document recommended that traffic control devices should be subjected to two full-scale crash tests with an 1,808-lb (820-kg) small passenger car, designated 820C. For Test Level 3 (TL-3) conditions, the slow-speed test was specified at 21.7 mph (35 km/h), while 62.1 mph (100 km/h) was required for the high-speed test. The low-speed test was intended to evaluate the breakaway, fracture, or yielding mechanism of the devices, whereas the high-speed test was intended to evaluate vehicular stability. The FHWA has not required the low-speed test for any work-zone traffic control devices weighing less than 100 lb (45 kg) and, as a result, this test was not normally necessary. These tests were normally conducted perpendicular to the device (0 degrees). However, these devices were often situated on the roadway where an impact could occur at other angle orientations, such as at 90 degrees at an intersection roadway. Thus, it became generally recognized that an additional test should be performed on such devices at the target speed of 62.1 mph (100 km/h) and at a target impact angle of 90 degrees. NCHRP Report No. 350 states that “if the primary concern regarding the impact behavior of a traffic control device is penetration of the test article or parts thereof into the occupant compartment as opposed to occupant impact velocity and ridedown acceleration and/or vehicular stability, it may be preferable to use the 2000P vehicle [4,409-lb (2,000-kg) ¾-ton pickup truck] in lieu of or in addition to the 820C vehicle. The choice will depend on the front profile of the two vehicles in relation to the geometry of the test article and elements thereon that could potentially penetrate the occupant compartment.” However, because a 2000P

test was not specifically required, this test was never conducted, even when occupant compartment penetration was the primary safety concern.

Following the completion of several crash test evaluations of various work-zone traffic control devices, Midwest Roadside Safety Facility (MwRSF) researchers recognized that the design of many work-zone traffic control devices was tuned to the geometry of small passenger cars with a relatively short hood and low roof structure. Consequently, there was concern that these systems might behave much differently when impacted by a vehicle with a longer hood and/or a higher roof.

In 2003, the Dicke Tool Company funded a project at the MwRSF to evaluate the safety performance of NCHRP Report No. 350-accepted work-zone sign support systems for impacts with a ¾-ton pickup truck. These crash tests were performed with a bogie vehicle configured with a frontal profile that replicated the geometry of a 2000P pickup truck. An evaluation of the results from the bogie testing revealed a propensity for some FHWA-accepted, portable sign support systems to impact the windshield region of a simulated pickup truck during high-speed collisions, as shown in Figure 1. Although the bogie vehicle was not configured with an actual glass windshield, the results demonstrated a significant risk for test article penetration through the windshield.

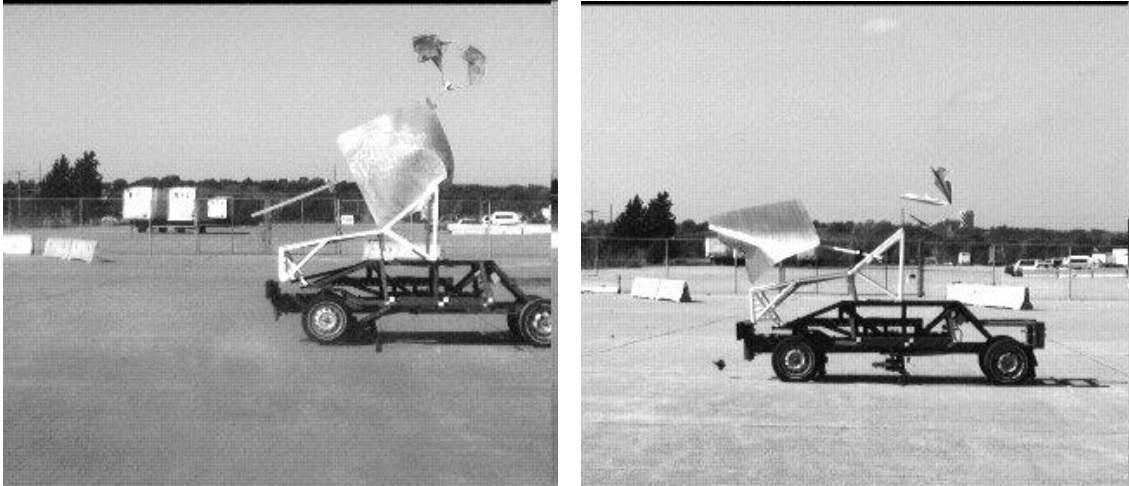

Figure 1. Existing Work-Zone Traffic Control Devices in Simulated Truck Bogie Testing

In the late 1990's, roadside safety experts, State DOT representatives, Federal government officials, and industry personnel began discussions and preparations relative to eventually updating the NCHRP Report No. 350 safety performance guidelines used for evaluating the performance of roadside safety devices. The update was intended to improve upon existing procedures, make considerations for changes in vehicle fleet, provide criteria for new roadside hardware categories, and re-evaluate the appropriateness of the impact conditions.

In 1997, NCHRP Project 22-14(1) was undertaken at the Texas Transportation Institute (TTI) to evaluate the relevance of the crash testing procedures, assess the need to update NCHRP Report No. 350, and provide recommendations for their implementation. In 2002, NCHRP Project 22-14(2) was initiated at MwRSF to prepare the revised safety performance evaluation guidelines and assess the effects of the proposed guidelines on existing hardware. These revised safety performance evaluation criteria, MASH [27], were recently approved by AASHTO.

Over the last six years, MwRSF researchers prepared the MASH guidelines and evaluated the appropriateness of these proposed guidelines through the use of full-scale crash testing on many different hardware categories. Test vehicle selection for full-scale crash testing was updated to reflect the current vehicle fleet, which included a revised small passenger car,

designated 1100C, weighing 2,425 lb (1,100 kg) as well as a new four-door, half-ton pickup truck, designated 2270P, weighing 5,000 lb (2,268 kg). At the TL-3 condition, the small car test speeds are 19 mph (31 km/h) and 62 mph (100 km/h), while the pickup truck test speed is 62 mph (100 km/h). The maximum occupant compartment deformations allowed in the MASH evaluation criteria are more precisely defined than those provided in NCHRP Report No. 350.

2.2 NCHRP Report No. 350 Work-Zone Testing

There are many variations in the design of portable, work-zone sign support systems. The most common design variations include the base, heights of sign and mast, base/sign holder vertical tubing, mast configuration, sign panel material, sign locking mechanism, the horizontal and vertical crossbracing, and the presence of lights and flags. The general schematics of typical work-zone sign support systems are shown in Figure 2. Although testing appears to indicate that many of these design variations can affect a system's safety performance, the importance of the effects have not been adequately quantified. Common design variations in work-zone sign systems are listed in Table 1.

2.2.1 Full-Scale Tests

Numerous crash tests have been conducted on work-zone sign support systems with NCHRP Report No. 350, as shown in Table 2. Many of these devices have been accepted by the FHWA as meeting the NCHRP Report No. 350 safety criteria.

Historically, work-zone sign support systems with the bottom of the sign panels located 12 in. (305 mm) above the ground have provided acceptable safety performance when subjected to small car crash testing. Prior testing on systems with very short masts have not demonstrated a propensity for the mast to contact nor penetrate the windshield [4,5,8,10,23,25]. Unfortunately, a short mast does not provide much vertical nor lateral support to the sign panel, so the panel can

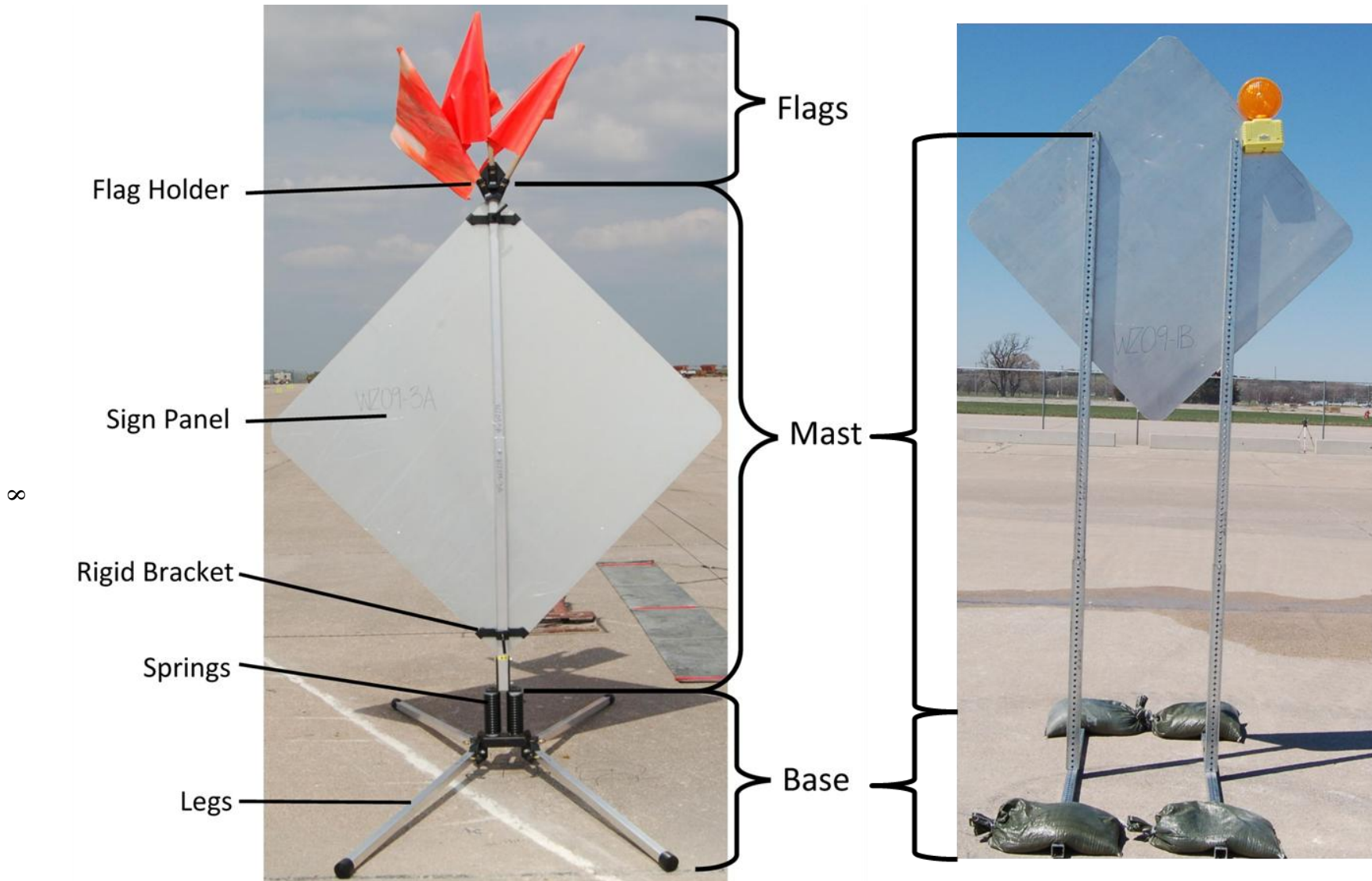

Figure 2. Features of a Typical Work-Zone Sign Support System

lay-over in a heavy wind event, making the sign difficult to read. For this reason, systems with a mast spanning the entire height of the sign panel were found to be more desirable. Further, during full-scale crash testing, the base of the sign support system has been observed to penetrate the floorboard if it became lodged under the car, but this event was a rare phenomenon.

Several system features such as the height of the mast, its fracture or yielding mechanism, and the sign panel weight and attachment, influence the point where the sign system strikes the vehicle. Low-mounted sign supports, with a mast extending to the top of the sign panel or higher, have shown the potential for the mast and sign panel to rotate around the hood and into the windshield [4,5,9-12,16,17,19,20,23,25,26]. On the contrary, high-mounted sign support systems have often bridged the windshield and impacted the roof or did not contact these regions of the small car [4,5,9-11,17,21-23,25,26].

Table 1. Work-Zone Sign Support Systems Design Variations









BASE – legs and bottom support system				
Layout		Connection to Mast		
Name	Shape	Name	Description	
X-footprint		Double vertical springs	2 coil vertical springs	
		Extension spring	1 coil vertical spring	
		Rigid	Welded directly to base	
		Torsion spring	1 or 2 horizontal springs	
		Slipbase	Entire base can release	
H-footprint dual uprights		Mast slides into base	For skid-mounted, H- and II-footprint	
H-footprint single upright				
Parallel dual upright		Mast slides over base	For skid-mounted, H- and II-footprint	
Skid-mounted				
Tripod		Tripod	Plate connecting 3 legs	
Ground single upright		Ground mounted	Rigid connection in ground	
Rubber base		Rubber base connector	Specific connection for rubber base layout	
HEIGHTS				
Height to Bottom of Sign – varies from 12” to 84” Height to Top of Sign – varies from 51” to 152” Height to Top of Mast – varies from 37” to 150” Height to Top of Flags – varies from 75” to 173”				
BASE/SIGN HOLDER VERTICAL TUBING		MAST – vertical support		
Dimension – varies from 3/4” to 2 1/2” Length – varies from 3” to 59” Wall Thickness – varies from 0.06” to 0.18”		No. of Stages –from 1 to 3 telescoping tubes Material – either steel or aluminum Dimension – varies from 1” to 2 1/2” Wall Thickness – varies from 0.06” to 0.18”		
SIGN LOCKING MECHANISM		SIGN PANEL		
Name	Description	Material	Thickness	
Channel Holder	Holds crossbrace vertical	Rigid	Aluminum	0.079” to 0.138”
Roll-up Bracket	Holds crossbracing center		Plastic	0.642”
Nut and Bolt	Bolted thru panel and mast		Plywood	0.500” to 0.680”
Panel Clips	Holder for panel to rest on			
Locking Pin	Pin thru mast and crossbrace	Flexible	Mesh Roll-up	negligible
Crossbrace Lock	Crossbrace support bracket		Vinyl Roll-up	negligible
Rigid Brackets	Corner holder for rigid panels			
Thumbscrew Lock	Screws tight to crossbrace			
Slide Over Lock	Mast slides over base tubing			

Table 1. Work-Zone Sign Support Systems Design Variations (cont.)



CROSSBRACING – supports for flexible sign panels	
Aluminum Vertical	Horizontal
Dimension – varies from 1” to 1 ¼” Length – varies from quarter, half, and full length	Material – aluminum or fiberglass Dimension – 1” (only for aluminum) Thickness – varies from 0.185” to 0.260” Width – varies from 0.976” to 1.575” Length – varies from half or full length
Fiberglass Vertical	
Thickness – varies from 0.189” to 0.394” Width – varies from 1.181” to 1.260” Length – full length	
ATTACHMENTS	ORIENTATION
Flag Staff Material – wood or fiberglass Light Attached – addition of flashing warning light Sandbags Used – for extra leg weight	0 degrees 
	90 degrees 

Table 2. Prior Full Scale Crash Testing System Details

Test System No.	Base		Heights to				Base/Sign Holder Vert Tubing		
	Layout	Connection	Bottom of sign (mm)	Top of sign (mm)	Top of Mast (mm)	Top of flags (mm)	Dimension (mm)	Length (mm)	Wall Thickness (mm)
1	X	Rigid	356	2076	----	2486	38.1	600	1.52
2	X	Rigid	356	2076	----	2486	38.1	600	1.52
3	X	Torsion Spring	311	2019	----	2616	38.1	156	1.52
4	X	Torsion Spring	311	2019	----	2616	38.1	156	1.52
5	X	Extension Spring	1476	3194	3197	3840	50.8	279	3.05
6	X	Extension Spring	1476	3194	3197	3840	50.8	279	3.05
7	X	Rigid	470	2189	----	2677	31.8	584	1.68
8	X	Torsion Spring	337	2057	2388	3010	44.5	76	2.11
9	X	Torsion Spring	352	2073	----	2572	38.1	154	1.65
10	X	Torsion Spring	349	2067	----	2781	38.4	459	1.78
11	X	Torsion Spring	356	2070	----	2613	38.4	459	1.78
12	X	Rigid	327	2048	----	2518	31.8	432	1.68
13	X	Extension Spring	324	2038	----	2686	64.0	241	3.30
14	X	Extension Spring	578	2299	2397	2985	64.0	283	3.35
15	X	Torsion Spring	340	2045	----	2618	38.1	152	2.16
16	X	Dbl Vert Spring	413	2134	----	2692	38.1	152	2.16
17	X	Dbl Vert Spring	445	2161	----	2654	38.1	152	2.16
18	X	Torsion Spring	1740	3442	1740	4020	44.9	130	2.62
19	X	Torsion Spring	470	2178	----	2632	31.8	457	1.61
20	X	Torsion Spring	368	2083	----	2438	38.4	149	2.42
21	X	Rigid	460	2184	----	2642	31.9	584	1.58
22	X	Rigid	394	2108	----	2470	38.3	279	2.36
23	X	Torsion Spring	2120	3860	1942	4365	45.8	132	2.25
24	X	Rigid	467	2180	----	----	31.8	585	2.12
25	X	Torsion Spring	474	2196	2196	2780	45.8	129	2.54
26	X	Torsion Spring	325	2034	----	2599	38.7	154	1.90
27	H dual upright	Rigid	2235	3385	3112	----	44.6	54	2.54
28	X	Rigid	476	2184	----	----	25.8	660	2.95

---- Not Applicable

Table 2. Prior Full Scale Crash Testing System Details (cont.)

Test System No.	Mast (Larger dimensions given if more than one stage)				Sign Locking Mechanism	Sign Panel		Aluminum Vert Crossbrace	
	No. of Stages	Material	Dimension (mm)	Wall Thickness (mm)		Thick (mm)	Material	Dimension (mm)	Length
1	----	----	----	----	Thumbscrew Lock	----	Vinyl Roll-up	----	----
2	----	----	----	----	Thumbscrew Lock	----	Vinyl Roll-up	----	----
3	----	----	----	----	Slide Over Lock	----	Vinyl Roll-up	25.0	Half
4	----	----	----	----	Slide Over Lock	----	Vinyl Roll-up	25.0	Half
5	1	Aluminum	38.1	2.54	Nut & Bolt	----	Vinyl Roll-up	32.0	Full
6	1	Aluminum	38.1	2.54	Nut & Bolt	----	Vinyl Roll-up	32.0	Full
7	----	----	----	----	Slide Over Lock	----	Vinyl Roll-up	25.0	Half
8	3	Aluminum	38.1	2.54	Crossbrace Lock w/Clamp	----	Vinyl Roll-up	----	----
9	----	----	----	----	Slide Over Lock	----	Vinyl Roll-up	25.0	Full
10	----	----	----	----	Thumbscrew Lock	----	Vinyl Roll-up	----	----
11	----	----	----	----	Thumbscrew Lock	----	Vinyl Roll-up	----	----
12	----	----	----	----	Slide Over Lock	----	Vinyl Roll-up	25.0	Quarter
13	----	----	----	----	Slide Over Lock	----	Vinyl Roll-up	32.0	Full
14	2	Aluminum	38.4	2.67	Crossbrace Lock	----	Vinyl Roll-up	----	----
15	----	----	----	----	Slide Over Lock	----	Vinyl Roll-up	26.0	Half
16	----	----	----	----	Slide Over Lock	----	Vinyl Roll-up	25.0	Half
17	----	----	----	----	Slide Over Lock	----	Vinyl Roll-up	26.0	Full
18	2	Aluminum	38.4	2.53	Slide Over Lock	----	Vinyl Roll-up	25.0	Half
19	----	----	----	----	Slide Over Lock	----	Vinyl Roll-up	25.0	Half
20	----	----	----	----	Thumbscrew Lock	----	Vinyl Roll-up	----	----
21	----	----	----	----	Slide Over Lock	----	Vinyl Roll-up	25.0	Quarter
22	----	----	----	----	Thumbscrew Lock	----	Vinyl Roll-up	----	----
23	2	Aluminum	31.7	2.54	Slide Over Lock	----	Vinyl Roll-up	25.4	Half
24	----	----	----	----	Slide Over Lock	----	Vinyl Roll-up	25.6	Half
25	2	Aluminum	38.1	2.50	Crossbrace Lock	----	Vinyl Roll-up	----	----
26	----	----	----	----	Slide Over Lock	----	Vinyl Roll-up	25.4	Half
27	1	Aluminum	38.7	3.22	Nut & Bolt	2.1	Aluminum	----	----
28	----	----	----	----	Thumbscrew Lock	----	Vinyl Roll-up	----	----

---- Not Applicable

Table 2. Prior Full Scale Crash Testing System Details (cont.)

Test System No.	Fiberglass Vert Crossbrace			Horizontal Crossbrace					Flag Staff Material	Light Attached	Orientation	Sandbags Used
	Thickness (mm)	Width (mm)	Length	Material	Dimension (mm)	Thickness (mm)	Width (mm)	Length				
1	6.0	32.0	Full	Fiberglass	----	5.0	29.0	Full	Wood	N	0	N
2	6.0	32.0	Full	Fiberglass	----	5.0	29.0	Full	Wood	N	90	N
3	----	----	----	Aluminum	25.0	----	----	Half	Wood	Y	0	N
4	----	----	----	Aluminum	25.0	----	----	Half	Wood	Y	90	N
5	6.0	32.0	Full	Fiberglass	----	5.0	32.0	Full	Wood	N	0	N
6	6.0	32.0	Full	Fiberglass	----	5.0	32.0	Full	Wood	N	90	N
7	6.0	32.0	Full	Fiberglass	----	6.0	32.0	Full	Fiberglass	Y	0	N
8	6.0	32.0	Full	Fiberglass	----	6.0	32.0	Full	Wood	Y	0	N
9	----	----	----	Fiberglass	----	5.0	31.0	Full	Wood	N	0	N
10	9.0	31.0	Full	Fiberglass	----	6.0	31.0	Full	Fiberglass	N	0	N
11	10.0	31.0	Full	Fiberglass	----	6.0	31.0	Full	Wood	N	0	N
12	8.0	31.0	Full	Fiberglass	----	6.0	31.0	Full	Fiberglass	N	0	N
13	5.0	31.0	Full	Fiberglass	----	5.0	31.0	Full	Wood	Y	0	N
14	8.0	31.0	Full	Fiberglass	----	5.0	31.0	Full	Wood	Y	0	N
15	----	----	----	Fiberglass	----	5.0	30.0	Half	Wood	N	0	N
16	----	----	----	Fiberglass	----	5.0	30.0	Half	Wood	N	0	N
17	----	----	----	Fiberglass	----	5.0	31.0	Full	Wood	N	0	N
18	----	----	----	Fiberglass	----	5.0	40.0	Half	Wood	N	0	N
19	6.0	31.0	Full	Fiberglass	----	5.0	31.0	Full	Fiberglass	N	0	N
20	10.0	30.0	Full	Fiberglass	----	5.0	31.0	Full	Fiberglass	N	0	N
21	6.0	31.0	Full	Fiberglass	----	5.0	31.0	Full	Fiberglass	N	0	N
22	6.0	31.0	Full	Fiberglass	----	5.0	31.0	Full	Fiberglass	N	0	N
23	----	----	----	Fiberglass	----	5.0	30.0	Half	Wood	N	0	N
24	7.9	31.3	Full	Fiberglass	----	6.3	31.2	Full	----	N	0	N
25	6.6	30.8	Full	Fiberglass	----	6.3	30.7	Full	Wood	N	0	N
26	----	----	----	Fiberglass	----	5.3	30.1	Half	Wood	N	90	N
27	----	----	----	----	----	----	----	----	----	N	0	Y
28	4.8	30.8	Full	Fiberglass	----	4.8	30.8	Full	----	N	0	N

---- Not Applicable

Table 2. Prior Full Scale Crash Testing System Details (cont.)

Test System No.	Actual Performance Under NCHRP 350			
	Test Vehicle	Test Level	Pass/Fail	Method of Failure ¹
1	Festiva	3	P	----
2	Festiva	3	P	----
3	Festiva	3	P	----
4	Festiva	3	F	4
5	Festiva	3	P	----
6	Festiva	3	P	----
7	Festiva	3	F	1,2,3
8	Festiva	3	P	----
9	Festiva	3	P	----
10	Festiva	3	F	1,2,3
11	Festiva	3	P	----
12	Festiva	3	F	1,2,3
13	Festiva	3	P	----
14	Festiva	3	F	1,2,3
15	Festiva	3	P	----
16	Festiva	3	P	----
17	Festiva	3	P	----
18	Festiva	3	F	5
19	Festiva	3	P	----
20	Festiva	3	P	----
21	Festiva	3	F	1,2,3,4
22	Festiva	3	P	----
23	Festiva	3	F	1,2,3
24	Festiva	3	F	1,2,3,4
25	Festiva	3	F	1,2,3,4
26	Festiva	3	F	1,2,3,4
27	Festiva	3	F	1,2,3
28	Festiva	3	P	----

¹Method of Failure: 1-Severe Windshield Cracking, 2-Windshield Indentation, 3-Obstruction of Driver Visibility, 4-Windshield Penetration, 5-Other Penetration, 6-Roof Deformation, 7-Invalid Test

---- Not Applicable

Table 2. Prior Full Scale Crash Testing System Details (cont.)

Test System No.	Base		Heights to				Base/Sign Holder Vert Tubing		
	Layout	Connection	Bottom of sign (mm)	Top of sign (mm)	Top of Mast (mm)	Top of flags (mm)	Dimension (mm)	Length (mm)	Wall Thickness (mm)
29	X	Rigid	476	2184	----	----	25.9	660	3.50
30	X	Rigid	476	2191	----	3124	25.8	660	2.95
31	X	Rigid	476	2200	----	3124	25.9	660	3.50
32	Skid-mounted post	Rigid	394	2095	1443	----	27.3	326	unknown
33	Skid-mounted post	Rigid	394	2095	1443	----	27.3	326	unknown
34	Tripod	----	320	1940	----	1900	Legs: 25.4	1570	2.95
35	Tripod	----	320	1940	----	1900	Legs: 25.4	1570	2.95
36	X	Torsion Spring	2105	3820	2105	4391	44.6	129	2.25
37	X	Sgl Vert Spring	270	1988	----	2407	38.2	104	3.20
38	X	Dbl Vert Spring	430	2155	2220	2845	----	333 (spring)	----
39	X	Dbl Vert Spring	451	2171	2211	2855	----	333 (spring)	----
40	X	Dbl Vert Spring	1490	3220	3345	3944	----	400 (spring)	----
41	X	Dbl Vert Spring	1490	3220	3345	3988	----	400 (spring)	----
42	X	Torsion Spring	2134	3835	3835	4394	44.7	130	2.61
43	X	Torsion Spring	2134	3835	3835	4394	44.7	130	2.61
44	X	Extension Spring	2134	3854	3626	4185	44.8	178	2.53
45	X	Extension Spring	2134	3854	3626	4185	44.8	178	2.53
46	X	Torsion Spring	460	2165	2315	2956	44.4	132	2.16
47	X	Torsion Spring	460	2165	2315	2956	44.4	132	2.16
48	X	Torsion Spring	356	2073	----	2635	38.5	157	2.20
49	X	Sgl Vert Spring	305	2013	----	2400	38.4	105	2.80
50	X	Torsion Spring	457	2184	2299	2915	44.4	132	2.16
51	X	Torsion Spring	457	2184	2299	2915	44.4	132	2.16
52	X	Torsion Spring	1524	3258	3778	4401	44.7	130	2.61
53	X	Torsion Spring	1524	3258	3778	4401	44.7	130	2.61

---- Not Applicable

Table 2. Prior Full Scale Crash Testing System Details (cont.)

Test System No.	Mast (Larger dimensions given if more than one stage)				Sign Locking Mechanism	Sign Panel		Aluminum Vert Crossbrace	
	No. of Stages	Material	Dimension (mm)	Wall Thickness (mm)		Thick (mm)	Material	Dimension (mm)	Length
29	----	----	----	----	Thumbscrew Lock	----	Vinyl Roll-up	----	----
30	----	----	----	----	Thumbscrew Lock	----	Vinyl Roll-up	----	----
31	----	----	----	----	Thumbscrew Lock	----	Vinyl Roll-up	----	----
32	1	Steel	38.6	1.52	Bracket w/ Nut & Bolt	12.7	Plywood	----	----
33	1	Steel	38.6	1.52	Bracket w/ Nut & Bolt	12.7	Plywood	----	----
34	----	----	----	----	Panel Clips	----	Vinyl Roll-up	----	----
35	----	----	----	----	Panel Clips	----	Vinyl Roll-up	----	----
36	2	Aluminum	38.3	2.72	Slide Over Lock & Nut & Bolt btwn stand & mast	----	Vinyl Roll-up	25.6	Half
37	----	----	----	----	Thumbscrew Lock	----	Vinyl Roll-up	----	----
38	2	Steel	38.4	2.25	Locking Pin	----	Vinyl Roll-up	----	----
39	2	Aluminum	38.2	2.45	Locking Pin	----	Vinyl Roll-up	----	----
40	2	Aluminum	38.2	3.02	Locking Pin	----	Vinyl Roll-up	----	----
41	2	Aluminum	38.2	3.02	Locking Pin	----	Vinyl Roll-up	----	----
42	2	Aluminum	38.1	2.50	Crossbrace Lock	----	Vinyl Roll-up	----	----
43	2	Aluminum	38.1	2.50	Crossbrace Lock	----	Vinyl Roll-up	----	----
44	2	Aluminum	38.1	2.54	Crossbrace Lock	----	Vinyl Roll-up	----	----
45	2	Aluminum	38.1	2.54	Crossbrace Lock	----	Vinyl Roll-up	----	----
46	2	Aluminum	38.1	2.98	Crossbrace Lock	----	Mesh Roll-up	----	----
47	2	Aluminum	38.1	2.98	Crossbrace Lock	----	Mesh Roll-up	----	----
48	----	----	----	----	Slide Over Lock	----	Vinyl Roll-up	25.5	Half
49	----	----	----	----	Crossbrace Lock	----	Vinyl Roll-up	----	----
50	2	Aluminum	38.1	2.98	Thumbscrew Lock	16.3	Plastic	----	----
51	2	Aluminum	38.1	2.98	Thumbscrew Lock	16.3	Plastic	----	----
52	2	Aluminum	38.1	2.50	Thumbscrew Lock	16.3	Plastic	----	----
53	2	Aluminum	38.1	2.50	Thumbscrew Lock	16.3	Plastic	----	----

---- Not Applicable

Table 2. Prior Full Scale Crash Testing System Details (cont.)

Test System No.	Fiberglass Vert Crossbrace			Horizontal Crossbrace					Flag Staff Material	Light Attached	Orientation	Sandbags Used
	Thickness (mm)	Width (mm)	Length	Material	Dimension (mm)	Thickness (mm)	Width (mm)	Length				
29	4.8	30.8	Full	Fiberglass	----	4.8	30.8	Full	----	Y	0	N
30	4.8	30.8	Full	Fiberglass	----	4.8	30.8	Full	Fiberglass	Y	0	N
31	4.8	30.8	Full	Fiberglass	----	4.8	30.8	Full	Fiberglass	Y	0	N
32	----	----	----	----	----	----	----	----	----	Y	90	N
33	----	----	----	----	----	----	----	----	----	Y	0	N
34	9.5	30.9	Full	Fiberglass		6.4	31.1	Full	Wood	Y	90	N
35	9.5	30.9	Full	Fiberglass		6.4	31.1	Full	Wood	N	0	N
36	----	----	----	Fiberglass	----	5.1	29.8	Half	Wood	N	0	N
37	9.5	30.9	Full	Fiberglass	----	4.9	30.0	Full	Fiberglass	N	0	N
38	9.6	31.2	Full	Fiberglass	----	5.0	31.1	Full	Wood	N	90	N
39	9.6	31.2	Full	Fiberglass	----	5.0	31.1	Full	Wood	N	0	N
40	9.6	31.2	Full	Fiberglass	----	5.0	31.1	Full	Wood	N	90	N
41	9.6	31.2	Full	Fiberglass	----	5.0	31.1	Full	Wood	N	0	N
42	9.5	30.9	Full	Fiberglass	----	4.9	30.0	Full	Wood	N	0	N
43	9.5	30.9	Full	Fiberglass	----	4.9	30.0	Full	Wood	N	90	N
44	9.5	30.9	Full	Fiberglass	----	4.9	30.0	Full	Wood	N	0	N
45	9.5	30.9	Full	Fiberglass	----	4.9	30.0	Full	Wood	N	90	N
46	6.7	30.5	Full	Fiberglass	----	4.8	31.1	Full	Wood	N	0	N
47	6.7	30.5	Full	Fiberglass	----	4.8	31.1	Full	Wood	N	90	N
48	----	----	----	Fiberglass	----	4.9	24.8	Half	Wood	N	90	N
49	9.6	30.2	Full	Fiberglass	----	4.8	29.7	Full	Fiberglass	N	90	N
50	----	----	----	----	----	----	----	----	Wood	N	90	N
51	----	----	----	----	----	----	----	----	Wood	N	0	N
52	----	----	----	----	----	----	----	----	Wood	N	90	N
53	----	----	----	----	----	----	----	----	Wood	N	0	N

---- Not Applicable

Table 2. Prior Full Scale Crash Testing System Details (cont.)

Test System No.	Actual Performance Under NCHRP 350			
	Test Vehicle	Test Level	Pass/Fail	Method of Failure ¹
29	Festiva	3	P	----
30	Festiva	3	P	----
31	Festiva	3	P	----
32	Festiva	3	F	1,2,3,4
33	Festiva	3	F	1,2,3
34	Festiva	2	F	1,2,3,4
35	Festiva	2	P	----
36	Festiva	3	P	----
37	Festiva	3	P	----
38	Festiva	3	F	1,2,3
39	Festiva	3	F	1,2,3,4
40	Festiva	3	F	1,2,3
41	Festiva	3	P	----
42	Festiva	3	P	----
43	Festiva	3	P	----
44	Festiva	3	P	----
45	Festiva	3	P	----
46	Metro	3	P	----
47	Metro	3	F	1,2
48	Festiva	3	P	----
49	Festiva	3	P	----
50	Metro	3	P	----
51	Metro	3	P	----
52	Metro	3	P	----
53	Metro	3	P	----

¹Method of Failure: 1-Severe Windshield Cracking, 2-Windshield Indentation, 3-Obstruction of Driver Visibility, 4-Windshield Penetration, 5-Other Penetration, 6-Roof Deformation, 7-Invalid Test

---- Not Applicable

Table 2. Prior Full Scale Crash Testing System Details (cont.)

Test System No.	Base		Heights to				Base/Sign Holder Vert Tubing		
	Layout	Connection	Bottom of sign (mm)	Top of sign (mm)	Top of Mast (mm)	Top of flags (mm)	Dimension (mm)	Length (mm)	Wall Thickness (mm)
54	X	Torsion Spring	305	2026	2305	2927	44.9	130	2.22
55	X	Torsion Spring	305	2026	2305	2927	44.9	130	2.22
56	X	Sgl Vert Spring	318	2022	----	2572	19.2	216	2.16
57	X	Extension Spring	305	2022	2267	2643	44.5	133	2.33
58	Tripod	(added weight)	368	1994	----	1911	25.4	1581	1.74
59	Tripod	(added weight)	368	1994	----	1911	25.4	1581	1.74
60	Tripod	(added weight)	381	1911	----	1911	25.4	1567	1.85
61	Tripod	(short top)	330	1880	----	----	25.6	1302	2.54
62	X	Torsion Spring	305	2013	2400	3004	44.8	128	2.24
63	X	Torsion Spring	305	2003	2375	2991	44.7	128	2.28
64	Ground single upright	ground mtd	276	1982	2136	----	38.0	462	5.00
65	Ground single upright	ground mtd	288	2013	2136	----	38.0	457	5.00
66	Parallel dual upright	Mast slides into vertical stub	344	2005	1525	(Light) 1705	45.0	300	2.75
67	Parallel dual upright	Mast slides into vertical stub	344	2005	1525	(Light) 1705	45.0	300	2.75
68	Parallel dual upright	Mast slides into vertical stub	344	2173	2030	----	45.0	302	2.75
69	Parallel dual upright	Mast slides into vertical stub	1245	2160	2030	----	45.0	302	2.75
70	Parallel dual upright	Mast slides into vertical stub	473	2137	1829	(Light) 1626	38.1	302	2.75
71	Parallel dual upright	Mast slides into vertical stub	473	2137	1829	(Light) 1626	38.1	302	2.75
72	X	Torsion Spring	1518	3239	3162	3778	44.9	340	2.56
73	X	Torsion Spring	1518	3239	3162	3778	44.9	340	2.56
74	X	Torsion Spring	305	2013	2299	2927	44.9	340	2.61
75	X	Torsion Spring	305	2013	2299	2927	44.9	340	2.61

---- Not Applicable

Table 2. Prior Full Scale Crash Testing System Details (cont.)

Test System No.	Mast (Larger dimensions given if more than one stage)				Sign Locking Mechanism	Sign Panel		Aluminum Vert Crossbrace	
	No. of Stages	Material	Dimension (mm)	Wall Thickness (mm)		Thick (mm)	Material	Dimension (mm)	Length
54	2	Aluminum	38.2	2.55	Crossbrace Lock	----	Mesh Roll-up	----	----
55	2	Aluminum	38.2	2.55	Crossbrace Lock	----	Mesh Roll-up	----	----
56	----	----	----	----	Slide Over Lock	----	Mesh Roll-up	25.6	Half
57	2	Aluminum	38.1	2.56	Crossbrace Lock	----	Vinyl Roll-up	----	----
58	----	----	----	----	Panel Clips	----	Vinyl Roll-up	----	----
59	----	----	----	----	Panel Clips	----	Vinyl Roll-up	----	----
60	----	----	----	----	Panel Clips	----	Vinyl Roll-up	----	----
61	----	----	----	----	Panel Clips	----	Vinyl Roll-up	----	----
62	2	Aluminum	38.2	2.55	Crossbrace Lock	----	Mesh Roll-up	----	----
63	2	Aluminum	38.2	2.55	Crossbrace Lock	----	Vinyl Roll-up	----	----
64	1	Steel	25.0	4.50	Roll-up Bracket	----	Vinyl Roll-up	----	----
65	1	Steel	25.0	4.50	Rigid Brackets	2.8	Aluminum	----	----
66	2	Telespar Steel Tubing	38.0	2.70	Nut & Bolt	2.8	Aluminum	----	----
67	2	Telespar Steel Tubing	38.0	2.70	Nut & Bolt	2.8	Aluminum	----	----
68	2	Telespar Steel Tubing	38.0	2.75	Nut & Bolt	2.8	Aluminum	----	----
69	2	Telespar Steel Tubing	38.0	2.75	Nut & Bolt	3.0	Aluminum	----	----
70	2	Telespar Steel Tubing	44.5	2.05	Nut & Bolt	3.0	Aluminum	----	----
71	2	Telespar Steel Tubing	44.5	2.05	Nut & Bolt	3.0	Aluminum	----	----
72	3	Aluminum	38.4	2.58	Roll-up Bracket	----	Vinyl Roll-up	----	----
73	3	Aluminum	38.4	2.58	Roll-up Bracket	----	Vinyl Roll-up	----	----
74	2	Aluminum	38.3	2.62	Crossbrace Lock	----	Vinyl Roll-up	----	----
75	2	Aluminum	38.3	2.62	Crossbrace Lock	----	Vinyl Roll-up	----	----

---- Not Applicable

Table 2. Prior Full Scale Crash Testing System Details (cont.)

Test System No.	Fiberglass Vert Crossbrace			Horizontal Crossbrace					Flag Staff Material	Light Attached	Orientation	Sandbags Used
	Thickness (mm)	Width (mm)	Length	Material	Dimension (mm)	Thickness (mm)	Width (mm)	Length				
54	6.3	30.5	Full	Fiberglass	----	6.3	30.6	Full	Wood	N	0	N
55	6.3	30.5	Full	Fiberglass	----	6.3	30.6	Full	Wood	N	90	N
56	----	----	----	Fiberglass	----	4.9	29.9	Half	Wood	N	90	N
57	6.4	30.7	Full	Fiberglass	----	4.7	31.1	Full	Wood	N	0	N
58	6.3	30.5	Full	Fiberglass	----	6.4	30.5	Full	Wood	N	0	N
59	6.3	30.5	Full	Fiberglass	----	6.4	30.5	Full	Wood	N	90	N
60	6.6	30.9	Full	Fiberglass	----	6.5	30.9	Full	Wood	N	90	N
61	6.6	30.7	Full	Fiberglass	----	5.0	29.7	Full	----	N	90	N
62	6.6	30.7	Full	Fiberglass	----	5.0	29.7	Full	Wood	N	90	N
63	6.5	30.9	Full	Fiberglass	----	6.6	30.9	Full	Wood	N	90	N
64	9.6	31.2	Full	Fiberglass	---	5.1	30.8	Full	----	N	0	N
65	----	----	----	----	----	----	----	----	----	N	0	N
66	----	----	----	----	----	----	----	----	----	N	0	Y
67	----	----	----	----	----	----	----	----	----	N	90	Y
68	----	----	----	----	----	----	----	----	----	N	0	Y
69	----	----	----	----	----	----	----	----	----	N	90	Y
70	----	----	----	----	----	----	----	----	----	N	0	Y
71	----	----	----	----	----	----	----	----	----	N	90	Y
72	8.1	31.1	Full	Fiberglass	----	5.1	29.8	Full	Wood	N	90	N
73	8.1	31.1	Full	Fiberglass	----	5.1	29.8	Full	Wood	N	0	N
74	8.1	31.1	Full	Fiberglass	----	5.1	29.8	Full	Wood	N	90	N
75	8.1	31.1	Full	Fiberglass	----	5.1	29.8	Full	Wood	N	0	N

---- Not Applicable

Table 2. Prior Full Scale Crash Testing System Details (cont.)

Test System No.	Actual Performance Under NCHRP 350			
	Test Vehicle	Test Level	Pass/Fail	Method of Failure ¹
54	Metro	3	P	----
55	Metro	3	F	1,2,3,4
56	Festiva	3	P	----
57	Festiva	3	F	1,2,3
58	Festiva	2	P	----
59	Festiva	2	---	7
60	Festiva	2	P	----
61	Festiva	2	P	----
62	Metro	3	F	1,2,3,4
63	Metro	3	P	----
64	Metro	3	F	1,2,3,4
65	Metro	3	F	1,2,3,4
66	Metro	3	F	1,2,3,4
67	Metro	3	P	----
68	Metro	3	P	----
69	Metro	3	F	1,2,3,4
70	Metro	3	F	1,2,3,4
71	Metro	3	F	1,2,3,4
72	Metro	3	P	----
73	Metro	3	P	----
74	Metro	3	P	----
75	Metro	3	P	----

¹Method of Failure: 1-Severe Windshield Cracking, 2-Windshield Indentation, 3-Obstruction of Driver Visibility, 4-Windshield Penetration, 5-Other Penetration, 6-Roof Deformation, 7-Invalid Test

---- Not Applicable

Table 2. Prior Full Scale Crash Testing System Details (cont.)

Test System No.	Base		Heights to				Base/Sign Holder Vert Tubing		
	Layout	Connection	Bottom of sign (mm)	Top of sign (mm)	Top of Mast (mm)	Top of flags (mm)	Dimension (mm)	Length (mm)	Wall Thickness (mm)
76	X	Slip Base	1613	3277	3277	(Light) 3473	51.1	597	2.78
77	X	Slip Base	1613	3277	3277	(Light) 3473	51.1	597	2.78
78	X	Slip Base	1638	3302	3302	----	51.1	597	2.78
79	X	Slip Base	1638	3302	3302	----	51.1	597	2.78
80	X	Torsion Spring	400	2061	2294	2920	44.8	337	2.39
81	X	Torsion Spring	400	2061	2294	2920	44.8	337	2.39
82	X	Torsion Spring	381	2042	2301	2922	44.8	337	2.39
83	X	Torsion Spring	381	2042	2301	2922	44.8	337	2.39
84	Parallel dual upright	Mast slides into vertical stub	911	3254	2740	(Light) 2794	50.8	151	2.64
85	Parallel dual upright	Mast slides into vertical stub	911	3254	2740	(Light) 2794	50.8	151	2.64
86	Parallel dual upright	Mast slides into vertical stub	1540	3264	2743	(Light) 2597	50.8	152	2.67
87	Parallel dual upright	Mast slides into vertical stub	1540	3264	2743	(Light) 2597	50.8	152	2.67
88	Parallel dual upright	Mast slides over vertical stub	335	1995	959	(Light) 1481	38.1	305	2.74
89	Parallel dual upright	Mast slides over vertical stub	333	1994	959	(Light) 1480	38.1	305	2.74
90	Parallel dual upright w/ 2 horiz braces	Mast slides into vertical stub	333	1578	1511	----	50.8	127	4.50
91	Parallel dual upright w/ 2 horiz braces	Mast slides into vertical stub	333	1578	1511	----	50.8	127	4.50
92	Parallel dual upright w/ 2 horiz braces	Mast slides into vertical stub	333	1578	1511	----	50.8	127	4.50
93	Parallel dual upright w/ 2 horiz braces	Mast slides into vertical stub	305	2029	1219	----	63.5	178	4.50

---- Not Applicable

Table 2. Prior Full Scale Crash Testing System Details (cont.)

Test System No.	Mast (Larger dimensions given if more than one stage)				Sign Locking Mechanism	Sign Panel		Aluminum Vert Crossbrace	
	No. of Stages	Material	Dimension (mm)	Wall Thickness (mm)		Thick (mm)	Material	Dimension (mm)	Length
76	1	Steel	44.9	2.15	Nut & Bolt	2.0	Aluminum	----	----
77	1	Steel	44.9	2.15	Nut & Bolt	2.0	Aluminum	----	----
78	1	Steel	44.9	2.15	Nut & Bolt	2.0	Aluminum	----	----
79	1	Steel	44.9	2.15	Nut & Bolt	2.0	Aluminum	----	----
80	2	Aluminum	38.5	2.73	Panel Brackets	3.5	Aluminum	----	----
81	2	Aluminum	38.5	2.73	Panel Brackets	3.5	Aluminum	----	----
82	2	Aluminum	38.5	2.73	Panel Brackets	2.4	Aluminum	----	----
83	2	Aluminum	38.5	2.73	Panel Brackets	2.4	Aluminum	----	----
84	2	Telespar Steel Tubing	44.5	2.63	Nut & Bolt	15.9	Plywood	----	----
85	2	Telespar Steel Tubing	44.5	2.63	Nut & Bolt	15.9	Plywood	----	----
86	2	Telespar Steel Tubing	50.0	2.77	Nut & Bolt	15.9	Plywood	----	----
87	2	Telespar Steel Tubing	50.0	2.77	Nut & Bolt	15.9	Plywood	----	----
88	2	Telespar Steel Tubing	50.8	2.74	Nut & Bolt	2.7	Aluminum	----	----
89	2	Telespar Steel Tubing	50.8	2.74	Nut & Bolt	2.7	Aluminum	----	----
90	1	Steel	38.1	2.50	Nut & Bolt	2.8	Aluminum	----	----
91	1	Steel	38.1	2.50	Nut & Bolt	2.8	Aluminum	----	----
92	1	Steel	38.1	2.50	Nut & Bolt	2.8	Aluminum	----	----
93	1	Steel	50.8	4.50	Nut & Bolt	2.8	Aluminum	----	----

---- Not Applicable

Table 2. Prior Full Scale Crash Testing System Details (cont.)

Test System No.	Fiberglass Vert Crossbrace			Horizontal Crossbrace					Flag Staff Material	Light Attached	Orientation	Sandbags Used
	Thickness (mm)	Width (mm)	Length	Material	Dimension (mm)	Thickness (mm)	Width (mm)	Length				
76	----	----	----	----	----	----	----	----	----	N	0	Y
77	----	----	----	----	----	----	----	----	----	N	90	Y
78	----	----	----	----	----	----	----	----	----	N	0	Y
79	----	----	----	----	----	----	----	----	----	N	90	Y
80	----	----	----	----	----	----	----	----	Wood	N	0	N
81	----	----	----	----	----	----	----	----	Wood	N	90	N
82	----	----	----	----	----	----	----	----	Wood	N	0	N
83	----	----	----	----	----	----	----	----	Wood	N	90	N
84	----	----	----	----	----	----	----	----	----	N	90	Y
85	----	----	----	----	----	----	----	----	----	N	0	Y
86	----	----	----	----	----	----	----	----	----	N	90	Y
87	----	----	----	----	----	----	----	----	----	N	0	Y
88	----	----	----	----	----	----	----	----	----	N	0	Y
89	----	----	----	----	----	----	----	----	----	N	90	Y
90	----	----	----	----	----	----	----	----	----	N	0	N
91	----	----	----	----	----	----	----	----	----	N	90	N
92	----	----	----	----	----	----	----	----	----	N	0	N
93	----	----	----	----	----	----	----	----	----	N	0	N

---- Not Applicable

Table 2. Prior Full Scale Crash Testing System Details (cont.)

Test System No.	Actual Performance Under NCHRP 350			
	Test Vehicle	Test Level	Pass/Fail	Method of Failure ¹
76	Metro	3	P	----
77	Metro	3	P	----
78	Metro	3	P	----
79	Metro	3	P	----
80	Metro	3	F	1,2,3
81	Metro	3	F	2,4
82	Metro	3	F	1,2,3
83	Metro	3	P	----
84	Metro	3	F	1,2,3,4,5
85	Metro	3	P	----
86	Metro	3	P	----
87	Metro	3	P	----
88	Bogie	3	F	1,2,3
89	Bogie	3	F	1,2,3
90	Bogie	3	P	----
91	Bogie	3	P	----
92	Bogie	3	F	1,2,3,4
93	Bogie	3	P	----

¹Method of Failure: 1-Severe Windshield Cracking, 2-Windshield Indentation, 3-Obstruction of Driver Visibility, 4-Windshield Penetration, 5-Other Penetration, 6-Roof Deformation, 7-Invalid Test

---- Not Applicable

Table 2. Prior Full Scale Crash Testing System Details (cont.)

Test System No.	Base		Heights to				Base/Sign Holder Vert Tubing		
	Layout	Connection	Bottom of sign (mm)	Top of sign (mm)	Top of Mast (mm)	Top of flags (mm)	Dimension (mm)	Length (mm)	Wall Thickness (mm)
94	Parallel dual upright w/ 2 horiz braces	Mast slides into vertical stub	311	2035	1219	----	63.5	178	4.50
95	Parallel dual upright	Mast slides over vertical stub	1524	3048	2743	----	50.8	154	2.69
96	Parallel dual upright	Mast slides over vertical stub	1524	3048	2743	----	50.8	154	2.69
97	X	Dbl Vert Spring	1524	3251	3366	3937	44.5	483	2.41
98	X	Dbl Vert Spring	1524	3251	3366	3937	44.5	483	2.41
99	X	Dbl Vert Spring	1524	3251	3366	3937	44.5	483	2.41
100	X	Dbl Vert Spring	1524	3251	3366	3937	44.5	483	2.41
101	X	Dbl Vert Spring	1524	3251	3366	3937	44.5	483	2.41
102	X	Dbl Vert Spring	1524	3251	3366	3937	44.5	483	2.41
103	X	Dbl Vert Spring	1524	3251	3366	3937	44.5	483	2.41
104	X	Dbl Vert Spring	457	2184	2300	2794	44.5	203	2.71
105	X	Dbl Vert Spring	457	2184	2300	2794	44.5	203	2.71
106	X	Dbl Vert Spring	457	2184	2300	----	44.5	203	2.71
107	X	Dbl Vert Spring	457	2184	2300	2794	44.5	203	2.71
108	X	Dbl Vert Spring	457	2184	2300	2794	44.5	203	2.71
109	X	Dbl Vert Spring	457	2184	2300	2794	44.5	203	2.71
110	X	Dbl Vert Spring	457	2184	2300	2794	44.5	203	2.71
111	X	Dbl Vert Spring	457	2184	2300	2794	44.5	203	2.71
112	X	Dbl Vert Spring	1524	3251	3366	3937	44.5	483	2.41
113	X	Dbl Vert Spring	1524	3251	3366	3937	44.5	483	2.41
114	X	Dbl Vert Spring	1524	3251	3366	3937	44.5	483	2.41
115	X	Dbl Vert Spring	305	2032	----	2515	unknown	unknown	unknown
116	X	Dbl Vert Spring	305	2032	----	2515	unknown	unknown	unknown
117	X	Dbl Vert Spring	305	2032	----	----	unknown	unknown	unknown

---- Not Applicable

Table 2. Prior Full Scale Crash Testing System Details (cont.)

Test System No.	Mast (Larger dimensions given if more than one stage)				Sign Locking Mechanism	Sign Panel		Aluminum Vert Crossbrace	
	No. of Stages	Material	Dimension (mm)	Wall Thickness (mm)		Thick (mm)	Material	Dimension (mm)	Length
94	1	Steel	50.8	4.50	Nut & Bolt	2.8	Aluminum	----	----
95	2	Telespar Steel Tubing	50.8	2.74	Nut & Bolt	17.3	Plywood	----	----
96	2	Telespar Steel Tubing	50.8	2.74	Nut & Bolt	17.3	Plywood	----	----
97	2	Aluminum	38.1	2.54	Rigid Brackets	3.2	Aluminum	----	----
98	2	Aluminum	38.1	2.54	Rigid Brackets	3.2	Aluminum	----	----
99	2	Aluminum	38.1	2.54	Rigid Brackets	2.0	Aluminum	----	----
100	2	Aluminum	38.1	2.54	Rigid Brackets	2.0	Aluminum	----	----
101	2	Aluminum	38.1	2.54	Rigid Brackets	3.2	Aluminum	----	----
102	2	Aluminum	38.1	2.54	Rigid Brackets & Nut & Bolt	3.2	Aluminum	----	----
103	2	Aluminum	38.1	2.54	Nut & Bolt	3.2	Aluminum	----	----
104	2	Aluminum	38.1	2.54	Nut & Bolt	2.0	Aluminum	----	----
105	2	Aluminum	38.1	2.54	Nut & Bolt	2.0	Aluminum	----	----
106	2	Aluminum	38.1	2.54	Rigid Brackets & Nut & Bolt	2.0	Aluminum	----	----
107	2	Aluminum	38.1	2.54	Rigid Brackets & Nut & Bolt	2.0	Aluminum	----	----
108	2	Aluminum	38.1	2.54	Rigid Brackets	2.0	Aluminum	----	----
109	2	Aluminum	38.1	2.54	Rigid Brackets	2.0	Aluminum	----	----
110	2	Aluminum	38.1	2.54	Rigid Brackets	2.0	Aluminum	----	----
111	2	Aluminum	38.1	2.54	Rigid Brackets	2.0	Aluminum	----	----
112	2	Aluminum	38.1	2.54	Rigid Brackets	3.2	Aluminum	----	----
113	2	Aluminum	38.1	2.54	Rigid Brackets	2.0	Aluminum	----	----
114	2	Aluminum	38.1	2.54	Rigid Brackets	2.0	Aluminum	----	----
115	----	----	----	----	Channel Holder	----	Vinyl Roll-up	----	----
116	----	----	----	----	Channel Holder	----	Vinyl Roll-up	----	----
117	----	----	----	----	Thumbscrew Lock	----	Vinyl Roll-up	----	----

---- Not Applicable

Table 2. Prior Full Scale Crash Testing System Details (cont.)

Test System No.	Fiberglass Vert Crossbrace			Horizontal Crossbrace					Flag Staff Material	Light Attached	Orientation	Sandbags Used
	Thickness (mm)	Width (mm)	Length	Material	Dimension (mm)	Thickness (mm)	Width (mm)	Length				
94	----	----	----	----	----	----	----	----	----	N	90	N
95	----	----	----	----	----	----	----	----	----	N	90	Y
96	----	----	----	----	----	----	----	----	----	N	0	Y
97	----	----	----	----	----	----	----	----	Wood	N	0	N
98	----	----	----	----	----	----	----	----	Wood	N	90	N
99	----	----	----	----	----	----	----	----	Wood	N	0	N
100	----	----	----	----	----	----	----	----	Wood	N	90	N
101	----	----	----	----	----	----	----	----	Wood	N	0	N
102	----	----	----	----	----	----	----	----	Wood	N	0	N
103	----	----	----	----	----	----	----	----	Wood	N	0	N
104	----	----	----	----	----	----	----	----	Wood	N	0	N
105	----	----	----	----	----	----	----	----	Wood	N	90	N
106	----	----	----	----	----	----	----	----	----	N	0	N
107	----	----	----	----	----	----	----	----	Wood	N	90	N
108	----	----	----	----	----	----	----	----	Wood	N	0	N
109	----	----	----	----	----	----	----	----	Wood	N	90	N
110	----	----	----	----	----	----	----	----	Wood	N	0	N
111	----	----	----	----	----	----	----	----	Wood	N	90	N
112	----	----	----	----	----	----	----	----	Wood	N	90	N
113	----	----	----	----	----	----	----	----	Wood	N	0	N
114	----	----	----	----	----	----	----	----	Wood	N	90	N
115	9.5	31.8	Full	Fiberglass	----	4.8	31.8	Full	Fiberglass	N	0	N
116	9.5	31.8	Full	Fiberglass	----	4.8	31.8	Full	Fiberglass	N	90	N
117	9.5	31.8	Full	Fiberglass	----	4.8	31.8	Full	----	N	0	N

---- Not Applicable

Table 2. Prior Full Scale Crash Testing System Details (cont.)

Test System No.	Actual Performance Under NCHRP 350			
	Test Vehicle	Test Level	Pass/Fail	Method of Failure ¹
94	Bogie	3	P	----
95	Metro	3	F	1,2,3,4,5,6
96	Metro	3	F	1,2,3
97	Bogie	3	P	----
98	Bogie	3	P	----
99	Bogie	3	P	----
100	Bogie	3	P	----
101	Bogie	3	P	----
102	Bogie	3	P	----
103	Bogie	3	P	----
104	Bogie	3	P	----
105	Bogie	3	F?	1,2,3
106	Bogie	3	F?	1,2
107	Bogie	3	F?	1,2,3
108	Bogie	3	F	1,2,3
109	Bogie	3	F	1,2,3
110	Bogie	3	F	1,2,3
111	Bogie	3	P	----
112	Bogie	3	P	----
113	Bogie	3	P	----
114	Bogie	3	P	----
115	Bogie	3	F	1,2,3
116	Bogie	3	P	----
117	Bogie	3	P	----

¹Method of Failure: 1-Severe Windshield Cracking, 2-Windshield Indentation, 3-Obstruction of Driver Visibility, 4-Windshield Penetration, 5-Other Penetration, 6-Roof Deformation, 7-Invalid Test
 ---- Not Applicable

Table 2. Prior Full Scale Crash Testing System Details (cont.)

Test System No.	Base		Heights to				Base/Sign Holder Vert Tubing		
	Layout	Connection	Bottom of sign (mm)	Top of sign (mm)	Top of Mast (mm)	Top of flags (mm)	Dimension (mm)	Length (mm)	Wall Thickness (mm)
118	X	Dbl Vert Spring	305	2032	----	----	unknown	unknown	unknown
119	X	Sgl Vert Spring	343	1308	----	----	----	unknown	----
120	X	Sgl Vert Spring	343	1308	----	----	----	unknown	----
121	X	Dbl Vert Spring	457	2184	2300	2794	44.5	203	2.71
122	X	Dbl Vert Spring	457	2184	2300	2794	44.5	203	2.71
123	X	Dbl Vert Spring	457	2184	2300	2794	44.5	203	2.71
124	X	Dbl Vert Spring	457	2184	2300	2794	44.5	203	2.71
125	X	Dbl Vert Spring	1524	3251	3366	3937	44.5	483	2.41
126	X	Dbl Vert Spring	1524	3251	3366	3937	44.5	483	2.41
127	X	Dbl Vert Spring	1524	3251	3366	3937	44.5	483	2.41
128	X	Dbl Vert Spring	1524	3251	3366	----	44.5	483	2.41
129	X	Dbl Vert Spring	1524	3251	3366	3937	44.5	483	2.41
130	X	Dbl Vert Spring	1524	3251	3366	3937	44.5	483	2.41
131	X	Dbl Vert Spring	2134	3861	3976	4445	44.5	533	2.41
132	X	Dbl Vert Spring	2134	3861	3976	4445	44.5	533	2.41
133	X	Dbl Vert Spring	1490	3220	3345	3944	----	400 (spring)	----
134	X	Dbl Vert Spring	1490	3220	3345	3944	----	400 (spring)	----
135	X	Dbl Vert Spring	381	2108	2388	2896	----	unknown	----
136	X	Dbl Vert Spring	381	2108	2388	2896	----	unknown	----
137	ground single upright	ground mtd	447	2172	----	----	32.0	765	3.20
138	ground single upright	ground mtd	457	2181	----	----	32.0	762	3.20
139	ground single upright	ground mtd	457	2181	----	----	32.0	766	3.20
140	H single upright	Mast slides over vertical stub	873	1635	1575	----	50.8	305	2.65
141	H single upright	Mast slides over vertical stub	883	1645	1575	----	50.8	305	2.79
142	H single upright	Mast slides over vertical stub	876	1638	1575	----	50.8	305	2.79

---- Not Applicable

Table 2. Prior Full Scale Crash Testing System Details (cont.)

Test System No.	Mast (Larger dimensions given if more than one stage)				Sign Locking Mechanism	Sign Panel		Aluminum Vert Crossbrace	
	No. of Stages	Material	Dimension (mm)	Wall Thickness (mm)		Thick (mm)	Material	Dimension (mm)	Length
118	----	----	----	----	Thumbscrew Lock	----	Vinyl Roll-up	----	----
119	----	----	----	----	Thumbscrew Lock	----	Vinyl Roll-up	----	----
120	----	----	----	----	Thumbscrew Lock	----	Vinyl Roll-up	----	----
121	2	Aluminum	38.1	2.54	Roll-up Bracket	----	Vinyl Roll-up	----	----
122	2	Aluminum	38.1	2.54	Roll-up Bracket	----	Vinyl Roll-up	----	----
123	2	Aluminum	38.1	2.54	Rigid Brackets	2.0	Aluminum	----	----
124	2	Aluminum	38.1	2.54	Rigid Brackets	2.0	Aluminum	----	----
125	2	Aluminum	38.1	2.54	Rigid Brackets	2.0	Aluminum	----	----
126	2	Aluminum	38.1	2.54	Rigid Brackets	2.0	Aluminum	----	----
127	2	Aluminum	38.1	2.54	Nut & Bolt	2.0	Aluminum	----	----
128	2	Aluminum	38.1	2.54	Nut & Bolt	2.0	Aluminum	----	----
129	2	Aluminum	38.1	2.54	Roll-up Bracket	----	Vinyl Roll-up	----	----
130	2	Aluminum	38.1	2.54	Roll-up Bracket	----	Vinyl Roll-up	----	----
131	2	Aluminum	38.1	2.54	Roll-up Bracket	----	Vinyl Roll-up	----	----
132	2	Aluminum	38.1	2.54	Roll-up Bracket	----	Vinyl Roll-up	----	----
133	2	Aluminum	38.2	3.02	Rigid Brackets	2.0	Aluminum	----	----
134	2	Aluminum	38.2	3.02	Rigid Brackets	2.0	Aluminum	----	----
135	2	Steel	25.0	2.00	Rigid Brackets	2.0	Aluminum	----	----
136	2	Steel	25.0	2.00	Rigid Brackets	2.0	Aluminum	----	----
137	----	----	----	----	Roll-up Bracket	----	Vinyl Roll-up	----	----
138	----	----	----	----	Roll-up Bracket	----	Vinyl Roll-up	----	----
139	----	----	----	----	Roll-up Bracket	----	Vinyl Roll-up	----	----
140	2	Telespar Steel Tubing	63.5	3.30	Nut & Bolt	2.6	Aluminum	----	----
141	2	Telespar Steel Tubing	63.5	3.30	Nut & Bolt	2.3	Aluminum	----	----
142	2	Telespar Steel Tubing	63.5	3.30	Nut & Bolt	2.6	Aluminum	----	----

---- Not Applicable

Table 2. Prior Full Scale Crash Testing System Details (cont.)

Test System No.	Fiberglass Vert Crossbrace			Horizontal Crossbrace					Flag Staff Material	Light Attached	Orientation	Sandbags Used
	Thickness (mm)	Width (mm)	Length	Material	Dimension (mm)	Thickness (mm)	Width (mm)	Length				
118	9.5	31.8	Full	Fiberglass	----	4.8	31.8	Full	----	N	90	N
119	9.5	31.8	Full	Fiberglass	----	4.8	31.8	Full	----	N	0	N
120	9.5	31.8	Full	Fiberglass	----	4.8	31.8	Full	----	N	90	N
121	9.5	31.8	Full	Fiberglass	----	4.8	31.8	Full	Wood	N	0	N
122	9.5	31.8	Full	Fiberglass	----	4.8	31.8	Full	Wood	N	90	N
123	----	----	----	----	----	----	----	----	Wood	N	0	N
124	----	----	----	----	----	----	----	----	Wood	N	90	N
125	----	----	----	----	----	----	----	----	Wood	N	0	N
126	----	----	----	----	----	----	----	----	Wood	N	90	N
127	----	----	----	----	----	----	----	----	Wood	N	0	N
128	----	----	----	----	----	----	----	----	----	N	90	N
129	8.0	31.8	Full	Fiberglass	----	4.8	31.8	Full	Wood	N	0	N
130	8.0	31.8	Full	Fiberglass	----	4.8	31.8	Full	Wood	N	90	N
131	8.0	31.8	Full	Fiberglass	----	4.8	31.8	Full	Wood	N	0	N
132	8.0	31.8	Full	Fiberglass	----	4.8	31.8	Full	Wood	N	90	N
133	----	----	----	----	----	----	----	----	Wood	N	0	N
134	----	----	----	----	----	----	----	----	Wood	N	90	N
135	----	----	----	----	----	----	----	----	Wood	N	0	N
136	----	----	----	----	----	----	----	----	Wood	N	90	N
137	6.4	32.0	Full	Fiberglass	----	4.8	32.0	Full	----	Y	0	N
138	6.4	32.0	Full	Fiberglass	----	4.8	32.0	Full	----	N	90	N
139	6.4	32.0	Full	Fiberglass	----	4.8	32.0	Full	----	N	0	N
140	----	----	----	----	----	----	----	----	----	N	0	Y
141	----	----	----	----	----	----	----	----	----	N	0	Y
142	----	----	----	----	----	----	----	----	----	N	0	Y

---- Not Applicable

Table 2. Prior Full Scale Crash Testing System Details (cont.)

Test System No.	Actual Performance Under NCHRP 350			
	Test Vehicle	Test Level	Pass/Fail	Method of Failure ¹
118	Bogie	3	F	1,2,3
119	Bogie - Truck	3	P	----
120	Bogie - Truck	3	P	----
121	Bogie - Truck	3	F	1,2,3,4
122	Bogie - Truck	3	F	1,2,3,4
123	Bogie - Truck	3	?	1,2,3,6
124	Bogie - Truck	3	F	1,2,3,4
125	Bogie - Truck	3	?	1,2,3
126	Bogie - Truck	3	F	1,2,3,4
127	Bogie - Truck	3	P	----
128	Bogie - Truck	3	F	1,2,3,4,6
129	Bogie - Truck	3	?	1,2,3
130	Bogie - Truck	3	?	1,2,3
131	Bogie - Truck	3	?	2
132	Bogie - Truck	3	P	----
133	Bogie - Truck	3	F	1,2,3
134	Bogie - Truck	3	F	1,2,3,4,6
135	Bogie - Truck	3	?	1,2,3,6
136	Bogie - Truck	3	F	1,2,3,4
137	Metro	3	F	1,2,3
138	Bogie	3	P	----
139	Bogie	3	P	----
140	Bogie	3	F	1,2,3
141	Bogie	3	F	1,2,3,4
142	Bogie	3	F	1,2,3,4

¹Method of Failure: 1-Severe Windshield Cracking, 2-Windshield Indentation, 3-Obstruction of Driver Visibility, 4-Windshield Penetration, 5-Other Penetration, 6-Roof Deformation, 7-Invalid Test

---- Not Applicable

Table 2. Prior Full Scale Crash Testing System Details (cont.)

Test System No.	Base		Heights to				Base/Sign Holder Vert Tubing		
	Layout	Connection	Bottom of sign (mm)	Top of sign (mm)	Top of Mast (mm)	Top of flags (mm)	Dimension (mm)	Length (mm)	Wall Thickness (mm)
143	H single upright	Mast slides over vertical stub	876	1638	1575	----	50.8	305	2.77
144	H single upright	Mast slides over vertical stub	879	1641	1575	----	50.8	305	2.74
145	H single upright	Mast slides over vertical stub	562	1883	1886	----	50.8	305	2.79
146	H single upright	Mast slides over vertical stub	568	1876	1886	----	50.8	305	2.77
147	Parallel dual upright	Mast slides over vertical stub	410	2238	2172	----	38.1	302	2.79
148	Parallel dual upright	Mast slides over vertical stub	413	2242	2172	----	38.1	305	2.79
149	Parallel dual upright	Mast slides over vertical stub	619	2445	2382	----	38.1	305	2.79
150	Parallel dual upright	Mast slides over vertical stub	619	2451	2388	----	38.1	302	3.10
151	Parallel dual upright	Mast slides over vertical stub	616	2445	2375	----	38.4	302	2.84
152	Parallel dual upright w/horiz brace	Mast slides over vertical stub	311	2146	2089	----	38.1	305	2.79
153	Parallel dual upright	Mast slides over vertical stub	508	2032	1994	----	38.1	305	2.79
154	Parallel dual upright	Mast slides over vertical stub	772	2291	2235	----	38.1	305	2.79
155	Parallel dual upright	Mast slides over vertical stub	740	1988	1562	----	38.1	302	2.79
156	Parallel dual upright	Mast slides over vertical stub	740	1988	1562	----	38.1	302	2.79
157	Parallel dual upright	Mast slides over vertical stub	740	1988	1562	----	38.1	305	2.79

---- Not Applicable

Table 2. Prior Full Scale Crash Testing System Details (cont.)

Test System No.	Mast (Larger dimensions given if more than one stage)				Sign Locking Mechanism	Sign Panel		Aluminum Vert Crossbrace	
	No. of Stages	Material	Dimension (mm)	Wall Thickness (mm)		Thick (mm)	Material	Dimension (mm)	Length
143	2	Telespar Steel Tubing	63.5	3.30	Nut & Bolt	2.3	Aluminum	----	----
144	2	Telespar Steel Tubing	63.5	3.30	Nut & Bolt	2.3	Aluminum	----	----
145	2	Telespar Steel Tubing	63.5	3.60	Nut & Bolt	3.5	Aluminum	----	----
146	2	Telespar Steel Tubing	63.5	3.60	Nut & Bolt	2.5	Aluminum	----	----
147	2	Telespar Steel Tubing	50.8	3.30	Nut & Bolt	2.5	Aluminum	----	----
148	2	Telespar Steel Tubing	50.8	4.00	Nut & Bolt	2.5	Aluminum	----	----
149	2	Telespar Steel Tubing	50.8	3.30	Nut & Bolt	3.3	Aluminum	----	----
150	2	Telespar Steel Tubing	50.8	4.00	Nut & Bolt	3.1	Aluminum	----	----
151	2	Telespar Steel Tubing	50.8	2.90	Nut & Bolt	3.1	Aluminum	----	----
152	2	Telespar Steel Tubing	50.8	3.30	Nut & Bolt	2.5	Aluminum	----	----
153	2	Telespar Steel Tubing	50.8	3.30	Nut & Bolt	2.5	Aluminum	----	----
154	2	Telespar Steel Tubing	50.8	3.30	Nut & Bolt	2.5	Aluminum	----	----
155	2	Telespar Steel Tubing	50.8	3.30	Nut & Bolt	2.8	Aluminum	----	----
156	2	Telespar Steel Tubing	50.8	3.30	Nut & Bolt	2.5	Aluminum	----	----
157	2	Telespar Steel Tubing	50.8	3.30	Nut & Bolt	2.5	Aluminum	----	----

---- Not Applicable

Table 2. Prior Full Scale Crash Testing System Details (cont.)

Test System No.	Fiberglass Vert Crossbrace			Horizontal Crossbrace					Flag Staff Material	Light Attached	Orientation	Sandbags Used
	Thickness (mm)	Width (mm)	Length	Material	Dimension (mm)	Thickness (mm)	Width (mm)	Length				
143	----	----	----	----	----	----	----	----	----	N	0	Y
144	----	----	----	----	----	----	----	----	----	N	90	Y
145	----	----	----	----	----	----	----	----	----	N	0	Y
146	----	----	----	----	----	----	----	----	----	N	90	Y
147	----	----	----	----	----	----	----	----	----	N	0	Y
148	----	----	----	----	----	----	----	----	----	N	90	Y
149	----	----	----	----	----	----	----	----	----	N	0	Y
150	----	----	----	----	----	----	----	----	----	N	0	Y
151	----	----	----	----	----	----	----	----	----	N	90	Y
152	----	----	----	----	----	----	----	----	----	N	0	Y
153	----	----	----	----	----	----	----	----	----	N	0	Y
154	----	----	----	----	----	----	----	----	----	N	0	Y
155	----	----	----	----	----	----	----	----	----	N	0	Y
156	----	----	----	----	----	----	----	----	----	N	90	Y
157	----	----	----	----	----	----	----	----	----	N	90	Y

---- Not Applicable

Table 2. Prior Full Scale Crash Testing System Details (cont.)

Test System No.	Actual Performance Under NCHRP 350			
	Test Vehicle	Test Level	Pass/Fail	Method of Failure ¹
143	Bogie	3	P	----
144	Bogie	3	P	----
145	Bogie	3	P	----
146	Bogie	3	P	----
147	Bogie	3	P	----
148	Bogie	3	F	1,2,3
149	Bogie	3	F	1,2,3,6
150	Bogie	3	P	----
151	Bogie	3	P	----
152	Bogie	3	F	1,2,3,4
153	Bogie	3	F	1,2,3,4
154	Bogie	3	F	1,2,3,4
155	Bogie	3	P	----
156	Bogie	3	F	1,2,3
157	Bogie	3	F	1,2,3,4

¹Method of Failure: 1-Severe Windshield Cracking, 2-Windshield Indentation, 3-Obstruction of Driver Visibility, 4-Windshield Penetration, 5-Other Penetration, 6-Roof Deformation, 7-Invalid Test

---- Not Applicable

Table 2. Prior Full Scale Crash Testing System Details (cont.)

Test System No.	Base		Heights to				Base/Sign Holder Vert Tubing		
	Layout	Connection	Bottom of sign (mm)	Top of sign (mm)	Top of Mast (mm)	Top of flags (mm)	Dimension (mm)	Length (mm)	Wall Thickness (mm)
158	Parallel dual upright w/horiz brace	Mast slides over vertical stub	483	1988	1562	----	38.1	305	2.79
159	Parallel dual upright w/horiz brace	Mast slides over vertical stub	740	1988	1562	----	38.1	302	2.79
160	Parallel dual upright	Mast slides over vertical stub	1565	3229	2784	----	44.5	305	2.84
161	Parallel dual upright	Mast slides over vertical stub	1568	3232	2784	----	44.5	305	2.87
162	Parallel dual upright	Mast slides over vertical stub	2134	3787	3378	----	44.5	305	2.84
163	Parallel dual upright	Mast slides over vertical stub	2134	3787	3378	----	44.5	305	2.87
164	H single upright	Mast slides over vertical stub	2143	2905	2845	----	50.8	305	2.84
165	H single upright	Mast slides over vertical stub	2143	2905	2845	----	50.8	305	2.79
166	Parallel dual upright w/ 3 horiz braces	Mast slides in vertical stub	305	1969	1524	----	32.0	152	2.56
167	X	Torsion Spring	381	2099	2369	2915	47.6	340	2.10
168	X	Torsion Spring	381	2099	2369	2915	47.6	340	2.10
169	X	DbI Vert Spring	305	2019	1892	2591	44.5	203	2.40
170	X	Rigid	914	2629	2629	2997	38.1	279	2.24
171	X	Rigid	(Flag Holder) 1432	----	2616	3321	38.1	279	2.03
172	X	DbI Vert Spring	305	2019	2553	3251	44.5	206	2.63
173	X	DbI Vert Spring	457	2172	1073	2896	44.5	203	2.71
174	Rubber Base	Base connector	305	1994	----	----	41.3	289	3.00
175	Rubber Base	Base connector	305	1994	----	----	41.3	289	2.92

---- Not Applicable

Table 2. Prior Full Scale Crash Testing System Details (cont.)

Test System No.	Mast (Larger dimensions given if more than one stage)				Sign Locking Mechanism	Sign Panel		Aluminum Vert Crossbrace	
	No. of Stages	Material	Dimension (mm)	Wall Thickness (mm)		Thick (mm)	Material	Dimension (mm)	Length
158	2	Telespar Steel Tubing	50.8	3.30	Nut & Bolt	2.5	Aluminum	----	----
159	2	Telespar Steel Tubing	50.8	3.30	Nut & Bolt	2.5	Aluminum	----	----
160	2	Telespar Steel Tubing	57.2	3.30	Nut & Bolt	2.6	Aluminum	----	----
161	2	Telespar Steel Tubing	57.2	3.00	Nut & Bolt	2.6	Aluminum	----	----
162	2	Telespar Steel Tubing	57.2	3.00	Nut & Bolt	2.5	Aluminum	----	----
163	2	Telespar Steel Tubing	57.2	3.00	Nut & Bolt	2.5	Aluminum	----	----
164	2	Telespar Steel Tubing	50.8	2.90	Nut & Bolt	2.7	Aluminum	----	----
165	2	Telespar Steel Tubing	50.8	2.80	Nut & Bolt	2.7	Aluminum	----	----
166	1	Steel	25.0	1.78	Nut & Bolt	2.3	Aluminum	----	----
167	2	Aluminum	38.1	2.54	Rigid Brackets	2.0	Aluminum	----	----
168	2	Aluminum	38.1	2.54	Rigid Brackets	12.7	Plywood	----	----
169	2	Aluminum	38.1	2.65	Roll-up Bracket	----	Vinyl Roll-up	----	----
170	2	Aluminum	31.8	2.59	Roll-up Bracket	----	Vinyl Roll-up	----	----
171	2	Aluminum	31.8	2.53	----	----	5 flags	----	----
172	3	Aluminum	38.1	2.60	Roll-up Bracket	----	Vinyl Roll-up	----	----
173	2	Aluminum	38.1	2.59	Rigid Brackets	12.7	Plywood	----	----
174	----	----	----	----	Channel Holder	----	Vinyl Roll-up	----	----
175	----	----	----	----	Channel Holder	----	Vinyl Roll-up	----	----

---- Not Applicable

Table 2. Prior Full Scale Crash Testing System Details (cont.)

Test System No.	Fiberglass Vert Crossbrace			Horizontal Crossbrace					Flag Staff Material	Light Attached	Orientation	Sandbags Used
	Thickness (mm)	Width (mm)	Length	Material	Dimension (mm)	Thickness (mm)	Width (mm)	Length				
158	----	----	----	----	----	----	----	----	----	N	90	Y
159	----	----	----	----	----	----	----	----	----	N	90	Y
160	----	----	----	----	----	----	----	----	----	N	0	Y
161	----	----	----	----	----	----	----	----	----	N	90	Y
162	----	----	----	----	----	----	----	----	----	N	0	Y
163	----	----	----	----	----	----	----	----	----	N	90	Y
164	----	----	----	----	----	----	----	----	----	N	0	Y
165	----	----	----	----	----	----	----	----	----	N	90	Y
166	----	----	----	----	----	----	----	----	----	N	0	Y
167	----	----	----	----	----	----	----	----	Wood	N	0	N
168	----	----	----	----	----	----	----	----	Wood	N	0	N
169	6.4	31.8	Full	Fiberglass	----	4.8	31.8	Full	Wood	N	0	N
170	4.8	31.8	Full	Fiberglass	----	4.8	31.8	Full	Wood	N	0	N
171	----	----	----	----	----	----	----	----	Wood	N	0	N
172	6.4	31.8	Full	Fiberglass	----	4.8	31.8	Full	Wood	N	0	N
173	----	----	----	----	----	----	----	----	Wood	N	90	N
174	7.9	31.8	Full	Fiberglass	----	4.8	31.8	Full	----	N	0	N
175	7.9	31.8	Full	Fiberglass	----	4.8	31.8	Full	----	N	90	N

---- Not Applicable

Table 2. Prior Full Scale Crash Testing System Details (cont.)

Test System No.	Actual Performance Under NCHRP 350			
	Test Vehicle	Test Level	Pass/Fail	Method of Failure ¹
158	Bogie	3	?	1,2,3
159	Bogie	3	P	----
160	Bogie	3	P	----
161	Bogie	3	P	----
162	Bogie	3	P	----
163	Bogie	3	P	----
164	Bogie	3	P	----
165	Bogie	3	P	----
166	Bogie	3	F	1,2,3,4
167	Metro	3	F	1,2,3
168	Metro	3	F	1,2,3,5
169	Bogie	3	P	----
170	Bogie	3	P	----
171	Bogie	3	P	----
172	Bogie	3	P	----
173	Bogie	3	P	----
174	Bogie	3	?	1,2,3
175	Bogie	3	?	1,2,3

¹Method of Failure: 1-Severe Windshield Cracking, 2-Windshield Indentation, 3-Obstruction of Driver Visibility, 4-Windshield Penetration, 5-Other Penetration, 6-Roof Deformation, 7-Invalid Test

---- Not Applicable

The mast's ability to fracture, break away, or yield affected its rotation. A mast with a frangible base reduced the amount of flex that developed in the sign panel and mast. This relatively quick release of the mast from the stand allowed the sign panel and mast to fall upon the vehicle with little additional force than what was developed through the impact event. On the other hand, when base-bending occurred, the sign panel and mast developed an additional load due to the lower part of the mast flexing away from the vehicle. When the mast was unloaded, the sign panel and mast had the tendency to "whip" downward onto the vehicle. In addition, when the mast bent around the front of the car before releasing from the base, the amount of flex in the sign panel and mast was increased. When the mast bent or had a delayed fracture, the base of the system was likely to be caught under the car, thus pulling the mast and sign panel into the car's hood or windshield. However with frangible masts, fracture usually occurred quickly, and the mast and sign panel were less likely to be pulled down. Thus, the probability of system contact with the roof was increased.

A heavy aluminum or plywood sign panel significantly raised the center of gravity of the mast. If the base fractured, the high center of gravity caused the mast and sign panel to rotate above the hood and windshield of the car. Depending on the height and orientation of the system, significant windshield damage was observed with rigid panels.

There were many design variations in the sign panel locking mechanism that attached the panel to the sign stand. Some were specifically designed for a certain panel material, while others were more universal and held a variety of materials. This affected the performance of the sign, especially in a 90-degree impact orientation. When the locking mechanism allowed the sign panel to flex away from the mast, there was a greater chance for the sign panel and mast to rotate into the windshield and result in extensive damage. On the other hand, if the locking mechanism

held the sign panel flush against the mast, the mast and sign panel rotated into the vehicle and impacted the upper portion of the windshield and/or the front of the roof, sometimes preventing major damage to the windshield [12].

Some of the masts that bridged the windshield on the small car, as shown in Figure 3, would likely impact the windshield of a pickup truck as indicated by the previous truck bogie testing shown in Figure 1. Many sign systems that utilized lower mounting heights for sign panels had masts that rotated around the hood. The height of the mast and sign panel controlled where and how the system impacted the small car. These features would affect where the same sign support system would impact a pickup truck. Some sign systems with taller mounting heights for sign panels and those oriented at 90 degrees easily passed over the small car with only slight contact to the roof, as shown in Figure 4. With the additional height and length of the pickup truck, these same sign systems would likely impact the windshield of the pickup truck.



Figure 3. Historical Tests of Low-Mounted Sign Support Systems



Figure 4. Historical Tests of High-Mounted Sign Support Systems

Vinyl roll-up sign panels have demonstrated problems with the crossbracing striking and penetrating the windshield [4,5,9,10,12]. When the crossbraces were made from fiberglass with a thickness less than $\frac{3}{16}$ in. (4.76 mm), damage to the windshield was limited. However, end users prefer rigid panels (i.e., plastics, aluminum laminates, aluminum, and plywood) due to their improved durability and increased resistance to folding under high winds. Unfortunately, these systems have more safety performance concerns than vinyl roll-up sign panels due to the increased impact force from the rigid material.

Plastic sign panels with no crossbraces were found to quickly release from the top and bottom sign locking brackets and did not result in a very concentrated impact. These plastic sign panels were flexible enough to dissipate some of the energy upon striking the windshield, thereby reducing the impact force between the sign panel and the impacting vehicle [11].

Rigid aluminum sign panels and masts that released quickly from the sign system were found to rotate onto the hood and then rebound into the air with little or no contact with the windshield, especially in the 90-degree orientation with short and tall systems. Sign panels and masts that did not release from the sign system were found to cause little or no damage to the vehicle with tall systems [16].

Flag attachments mounted on sign panels were traditionally believed to provide the worst case impact scenario. This belief was based upon tests wherein the flags and/or flag holder rotated into the windshield and caused damage. With higher systems, the flag holders impacted the roof, thereby eliminating the windshield damage problem [4,10]. However, if the flags disengaged, the metal flag holder itself likely created greater concern by striking and denting the roof [4,5,7,9-12]. Also, fiberglass-stuffed flag assemblies have caused severe denting on the vehicle's windshield and roof [4,7,9,10].

Ground-mounted temporary sign support systems have experienced similar safety performance problems as portable sign supports. Some posts rotated through the soil and caused a delayed release time, thus allowing the post to impact the windshield [14]. Only short-mast, in-ground sign systems have been found acceptable in meeting the NCHRP Report No. 350 safety performance criteria [24].

Sign systems that resemble a tripod shape when oriented 90 degrees to the vehicle were found to have the potential to rotate and rise into the air. This motion caused the top of the support to impact and penetrate the windshield [7,12]. Tripod sign support systems with a lower center of gravity were found to have fewer tendencies to exhibit this behavior.

2.3 MASH Testing of Permanent Sign Support Systems

TTI [28] successfully tested the compliance of two permanent sign support systems under MASH with the 2270P pickup truck. A thin-walled, steel tube sign support that inserted into a socket in a concrete footing was tested with a 5,013-lb (2,274-kg), ½-ton pickup truck. This system incorporated a 5/8-in. (16-mm) thick, plywood sign panel with a mounting height of 7 ft (2.13 m) from the ground to the bottom of the sign panel. A triangular slip-base sign support that anchored in a concrete footing was also tested with a 5,013-lb (2,274-kg), ½-ton pickup truck. The test article had a 5/8-in. (16-mm) thick plywood sign panel with a mounting height of 7 ft (2.13 m) from the ground to the bottom of the sign panel. Testing with the pickup truck was determined to be successful for the two permanent sign support systems, although the sign panel in the triangular slip base configuration produced two tears in the roof. No testing was performed on portable sign support systems.

3 RESEARCH APPROACH

The safety performance of selected NCHRP Report No. 350-accepted, work-zone sign support systems was re-examined in order to determine whether or not these systems would meet the MASH safety guidelines. Therefore, data was collected on all work-zone sign support systems that were crash tested at MwRSF. Sign system parameters and the safety performance results were recorded for each system crash tested.

The front-end geometries of the NCHRP Report No. 350 and MASH test vehicles were identified from available crash test reports. Using the MASH guidelines, the safety performance of the existing sign support systems was estimated by comparing the trajectories of system components during previous tests with the front profile of the new, larger test vehicles. When this analysis indicated that the sign system would likely strike the windshield or roof at a high rate of speed, the system was projected to fail MASH criteria. When the risk of impacting the windshield or the force of impact with the roof was deemed less likely, a subjective evaluation for the risk of failure was made. Sign systems that appeared to have almost no chance of contacting the windshield or roof were projected to pass the MASH criteria.

After evaluating more than 150 NCHRP Report No. 350 crash tests, 19 design parameters of sign support systems were identified that appeared to influence the impact performance of work-zone systems and included:

1. Base Layout
2. Base Connection Type
3. Height to Bottom of Sign
4. Height to Top of Mast
5. Height to Top of Flags
6. Base/Sign Holder Vertical Tubing Dimension
7. Base/Sign Holder Vertical Tubing Length
8. Base/Sign Holder Vertical Tubing Wall Thickness
9. Number of Mast Stages
10. Mast Material

11. Mast Dimension
12. Mast Wall Thickness
13. Sign Locking Mechanism
14. Sign Panel Material
15. Aluminum Vertical Crossbrace Length
16. Fiberglass Vertical Crossbrace Thickness
17. Horizontal Crossbrace Thickness
18. Flag Staff Material
19. Orientation

These parameters were then evaluated in order to determine which produced the highest risk of predicted failure. If 50 percent or more of systems were predicted to fail with a given parameter, then they were further analyzed in combination with other parameters in order to determine sign systems with a high propensity for failure. The resulting combinations were portable sign support systems that had the highest potential to fail the MASH safety performance evaluation criteria.

Four full-scale crash tests were conducted to evaluate the accuracy of the safety performance predictions. The test results were compared to the predictions, and guidelines were developed based on the results.

4 CRASH DATA

System parameters were collected from portable sign support systems that were included in 92 small car full-scale tests using NCHRP Report No. 350 guidelines, 65 small car bogie tests, and 18 pickup truck bogie tests, as shown in Table 2. An individual parameter for a sign system was described as a mechanism, geometrical measurement, or a particular property associated with a component of the system and include:

1. Base Layout
2. Base Connection Type
3. Height to Bottom of Sign
4. Height to Top of Sign
5. Height to Top of Mast
6. Height to Top of Flags
7. Base/Sign Holder Vertical Tubing Dimension
8. Base/Sign Holder Vertical Tubing Length
9. Base/Sign Holder Vertical Tubing Wall Thickness
10. Number of Mast Stages
11. Mast Material
12. Mast Dimension
13. Mast Wall Thickness
14. Sign Locking Mechanism
15. Sign Panel Thickness
16. Sign Panel Material
17. Aluminum Vertical Crossbrace Dimension
18. Aluminum Vertical Crossbrace Length
19. Fiberglass Vertical Crossbrace Thickness
20. Fiberglass Vertical Crossbrace Width
21. Fiberglass Vertical Crossbrace Length
22. Horizontal Crossbrace Material
23. Horizontal Crossbrace Dimension
24. Horizontal Crossbrace Thickness
25. Horizontal Crossbrace Width
26. Horizontal Crossbrace Length
27. Flag Staff Material
28. Attached Light
29. Orientation
30. Use of Sandbags

A sign system sub-parameter was described as a specific category under a parameter and was unique for each system. The sub-parameters were documented for each system under the parameter headings in Table 2. For example, sub-parameters for sign panel material are aluminum, plywood, vinyl, mesh, and plastic. A summary of the actual performance evaluation and method of failure for each crash test are also shown in Table 2. The researchers expanded the NCHRP Report No. 350 evaluation criteria to evaluate systems according to the methods of failure shown in Table 3.

Table 3. Actual and Predicted Performance Methods of Failure

Method of Failure	Description
1	Severe Windshield Cracking and Failure
2	Windshield Indention
3	Obstruction of Driver Visibility
4	Windshield Penetration
5	Other Occupant Compartment Penetration
6	Roof Deformation
7	Test Invalid due to Flying Debris

In an effort to predict whether each of the tabulated portable sign support systems would perform in an acceptable manner with the MASH criteria, the front-end dimensions were compared for the test vehicles specified in NCHRP Report No. 350 and those in MASH, as shown in Table 4. Dimensions were collected from prior test vehicles at MwRSF. Hood length was measured from the front of the engine hood to the base of the windshield and measured along the centerline of the vehicle. The windshield angle was measured with respect to the horizon. The bumper height was measured from the ground to the point of first contact with a sign support system. Windshield length was measured from the base of the windshield to the top

corner of the windshield along the diagonal. Finally, the roof height was measured from the ground to the highest point on the roof.

Table 4. Important Vehicle Dimensions

Parameter	Vehicle			
	820C	1100C	2000P	2270P
Hood Length [in. (mm)]	31.5 (800)	34.7 (881)	45.1 (1146)	41.0 (1041)
Bumper Height [in. (mm)]	18 (457)	18 (457)	26 (660)	27 (686)
Roof Height [in. (mm)]	58.0 (1473)	55.5 (1410)	73.3 (1862)	75.8 (1925)
Windshield Angle	39°	32°	42°	34°
Windshield Length [in. (mm)]	30.2 (767)	28.1 (714)	26.8 (681)	31.5 (800)

Note that the 1100C vehicle had a hood length approximately 3 in. (76 mm) longer, a smaller windshield incline, and a shorter windshield length than the 820C vehicle. Thus, the impact area of the windshield was slightly set back and smaller than that configured for the 820C. On the other hand, the 2270P vehicle had a smaller windshield incline and longer windshield length than the 2000P vehicle. Thus, the impact area of the windshield was larger for the 2270P. The hood length was approximately 4 in. (102 mm) shorter on the 2270P pickup truck, and the front profile was slightly taller than the 2000P pickup truck.

The vehicle geometries were compared to one another when reviewing the crash test videos and photographs. These comparisons were used to predict how each portable sign support system would perform according to the MASH TL-3 evaluation criteria when impacted by both an 1100C small car and a 2270P pickup truck at 62 mph (100 km/h). Since all small car bogie and full-scale vehicle tests were conducted with the 820C small car geometry, predictions for the 1100C and 2270P vehicles were made by comparing the MASH vehicle geometries to the 820C geometry. The pickup truck bogie tests had the 2000P geometry. Thus, predictions from the pickup truck bogie tests were made by comparing the 2000P and 2270P vehicle dimensions.

A ranking from 1 to 4, as shown in Table 5, was given to each portable sign support system based on its predicted chance of failing the MASH evaluation criteria. Each system ranking was paired with the failure modes presented in Table 3. Although the methods of failure were the same in both NCHRP Report No. 350 and MASH, the evaluation criteria were more objectively defined. In MASH, a test is classified as a failure if the maximum windshield indentation is greater than 3 in. (76 mm), a tear develops in the plastic liner, or the roof deformation is greater than 4 in. (102 mm). The ranking and predicted methods of failure for each system during 1100C and 2270P impacts are shown in Table 6. The system parameters are shown in Table 2.

Table 5. Predicted Chance of Failing MASH

Rank	Probability of Failure
1	75-100%
2	50-75%
3	25-50%
4	0-25%

Table 6. System Predictions

Test System No.	MASH Predicted Performance - Car		MASH Predicted Performance - Truck	
	Rank	Method of Failure	Rank	Method of Failure
1	4	----	3	1,2,3
2	4	----	3	1,2,3
3	3	1,2,3	3	1,2,3
4	2	4	3	1,2,3
5	4	----	2	1,2,3
6	4	----	2	1,2,3
7	1	1,2,3	3	1,2,3
8	4	----	2	1,2,3,4
9	2	1,2,3	4	----
10	1	1,2,3	4	----
11	3	1,2	4	----
12	1	1,2,3	4	----
13	4	----	1	1,2,3,4
14	1	1,2,3	2	1,2,3
15	3	1,2	3	1,2
16	4	----	2	1,2
17	4	----	2	1,2
18	2	5	3	1,2,3
19	3	1,2,3,4	4	----
20	3	1,2,3	4	----
21	1	1,2,3,4	2	1,2
22	3	1,2,3	3	1,2,3
23	----	----	----	----
24	1	1,2,3,4	2	1,2,3
25	1	1,2,3,4	2	1,2,3
26	1	1,2,3,4	2	1,2,3,4
27	1	1,2,3	2	1,2,3
28	4	----	4	----
29	4	----	3	1,2,3
30	4	----	4	----
31	4	----	4	----
32	3	1,2,3	3	1,2,3
33	1	1,2,3	3	1,2,3,4
34	1	1,2,3,4	3	1,2
35	3	1,2,3,4	4	----
36	4	----	3	1,2,6
37	4	----	4	----
38	2	1,2,3	3	1,2
39	1	1,2,3,4	3	1,2
40	1	1,2,3	1	1,2,4
41	4	----	2	1,2,4

Table 6. System Predictions (cont.)

Test System No.	MASH Predicted Performance - Car		MASH Predicted Performance - Truck	
	Rank	Method of Failure	Rank	Method of Failure
42	4	----	4	----
43	4	----	4	----
44	4	----	3	1,2,3
45	4	----	3	1,2,3,6
46	3	1,2	2	1,2,3,4
47	4	----	2	1,2,3,4
48	4	----	4	----
49	4	----	3	1,2
50	4	----	3	1,2
51	4	----	2	1,2,3,4
52	4	----	3	1,2,3,6
53	4	----	2	1,2,3
54	3	1,2,3,4	3	1,2,3,4
55	1	1,2,3,4	2	1,2,3
56	4	----	4	----
57	1	1,2,3	2	1,2,3
58	4	----	4	----
59	----	----	----	----
60	4	----	4	----
61	3	1,2,3,4	4	----
62	1	1,2,3,4	3	1,2
63	3	1,2	3	1,2,4
64	1	1,2,3,4	4	----
65	1	1,2,3,4	2	1,2,3,4
66	1	1,2,3,4	3	1,2
67	3	1,2	3	1,2,4
68	4	----	2	1,2
69	1	1,2,3,4	2	1,2,4
70	1	1,2,3,4	3	1,2,3
71	3	1,2,3,4	3	1,2,3
72	4	----	3	1,2,3,4
73	4	----	2	1,2,3,4
74	4	----	3	1,2
75	4	----	1	1,2,3,4
76	4	----	1	1,2,3,4,6
77	4	----	2	1,2,3,6
78	4	----	2	1,2,3,4,6
79	4	----	2	1,2,3,6
80	1	1,2,3	2	1,2,4
81	2	1,2,3	3	1,2
82	1	1,2,3	2	1,2,3

Table 6. System Predictions (cont.)

Test System No.	MASH Predicted Performance - Car		MASH Predicted Performance - Truck	
	Rank	Method of Failure	Rank	Method of Failure
83	3	1,2	2	1,2,4
84	1	1,2,3,4,5	1	1,2,3,4,6
85	4	----	2	1,2,3,4
86	3	1,2,6	1	1,2,3,4,6
87	4	----	1	1,2,3,4
88	1	1,2,3	3	1,2
89	2	1,2,3	3	1,2
90	4	----	4	----
91	4	----	3	1,2
92	1	1,2,3,4	3	1,2
93	2	1,2,3	3	1,2
94	4	----	3	1,2
95	1	1,2,3,4,5,6	1	1,2,3,4
96	1	1,2,3	1	1,2,3,4
97	4	----	3	1,2,3
98	4	----	1	1,2,3,4,6
99	4	----	1	1,2,3
100	3	1,2,3	1	1,2,3,4,6
101	4	----	2	1,2,3
102	4	----	2	1,2,3
103	4	----	2	1,2,3
104	4	----	2	1,2,3,4
105	3	1,2,3	2	1,2,3
106	2	1,2,3	2	1,2,3,4
107	3	1,2,3	2	1,2,3
108	1	1,2,3	2	1,2,3
109	2	1,2,3	3	1,2,3
110	1	1,2,3	3	1,2,3
111	4	----	2	1,2,3
112	4	----	2	1,2,3,4,6
113	4	----	1	1,2,3
114	4	----	1	1,2,3,4,6
115	1	1,2,3	3	1,2,3
116	3	1,2,3	4	----
117	4	----	4	----
118	3	1,2,3	4	----
119	----	----	4	----
120	----	----	4	----
121	----	----	1	1,2,3,4
122	----	----	1	1,2,3,4
123	----	----	3	1,2,3,6

Table 6. System Predictions (cont.)

Test System No.	MASH Predicted Performance - Car		MASH Predicted Performance - Truck	
	Rank	Method of Failure	Rank	Method of Failure
124	----	----	1	1,2,3,4
125	----	----	2	1,2,3
126	----	----	1	1,2,3,4
127	----	----	4	----
128	----	----	1	1,2,3,4,6
129	----	----	3	1,2,3
130	----	----	3	1,2,3
131	----	----	4	----
132	----	----	4	----
133	----	----	1	1,2,3
134	----	----	1	1,2,3,4,6
135	----	----	2	1,2,3,6
136	----	----	1	1,2,3,4
137	1	1,2,3	3	1,2,3
138	3	1,2	4	----
139	4	----	4	----
140	2	1,2,3	4	----
141	1	1,2,3,4	4	----
142	2	1,2,3,4	3	1,2,3
143	4	----	3	1,2,3
144	4	----	4	----
145	4	----	3	1,2,3
146	3	1,2,3	3	1,2,3
147	2	1,2,3,4	2	1,2,3,4
148	1	1,2,3,4	2	1,2,3,4
149	1	1,2,3,6	2	1,2,3,4
150	2	1,2,6	2	1,2,3,4
151	3	1,2,3	3	1,2,3
152	1	1,2,3,4	4	----
153	1	1,2,3,4	2	1,2,3,4
154	1	1,2,3,4	2	1,2,3,4
155	4	----	3	1,2,3
156	1	1,2,3,4	3	1,2,3
157	1	1,2,3,4	3	1,2,3
158	3	1,2,3	4	----
159	4	----	4	----
160	4	----	1	1,2,3,6
161	4	----	1	1,2,3,4
162	4	----	2	1,2,3,6
163	4	----	2	1,2,3,6
164	4	----	2	1,2,3,4

Table 6. System Predictions (cont.)

Test System No.	MASH Predicted Performance - Car		MASH Predicted Performance - Truck	
	Rank	Method of Failure	Rank	Method of Failure
165	4	----	1	1,2,3,4
166	2	1,2,3	3	1,2,3
167	1	1,2,3	2	1,2,3,4
168	1	1,2,3,5	2	1,2,3,4
169	4	----	4	----
170	4	----	3	1,2
171	4	----	3	1,2
172	4	----	3	1,2,3
173	4	----	3	1,2,3,4
174	3	1,2,3	4	----
175	3	1,2,3	4	----

After reviewing crash test videos and making failure predictions, only 19 of the 30 system parameters noted in Table 2 were further considered. MwRSF researchers selected these 19 system parameters that were deemed to contribute to the safety performance of portable sign supports and include:

1. Base Layout
2. Base Connection Type
3. Height to Bottom of Sign
4. Height to Top of Mast
5. Height to Top of Flags
6. Base/Sign Holder Vertical Tubing Dimension
7. Base/Sign Holder Vertical Tubing Length
8. Base/Sign Holder Vertical Tubing Wall Thickness
9. Number of Mast Stages
10. Mast Material
11. Mast Dimension
12. Mast Wall Thickness
13. Sign Locking Mechanism
14. Sign Panel Material
15. Aluminum Vertical Crossbrace Length
16. Fiberglass Vertical Crossbrace Thickness
17. Horizontal Crossbrace Thickness
18. Flag Staff Material
19. Orientation

Although these parameters were believed to individually influence the safety performance of a portable sign support system, combinations of parameters were also believed to contribute to reduced safety performance. Since there were too many parameters to analyze in combination with one another, an analysis was conducted to determine which parameter combinations would result in the greatest risk of failure for portable sign support systems using the MASH guidelines.

4.1 Parameter Analysis

A total of 175 systems were analyzed for pickup truck performance, and 157 systems were analyzed for small car performance. These systems included both successes and failures of NCHRP Report No. 350. Only the most critical methods of failure were analyzed and included: (4) windshield penetration, (5) other occupant compartment penetration, and (6) roof deformation. Only systems that were predicted to fail 50 to 100 percent of the time (Rank 1 or 2) by a critical method of failure were analyzed.

Portable sign support systems were categorized based on their sub-parameters. The total number of systems with a sub-parameter and the total number of systems with that sub-parameter that were predicted to fail were recorded, with a sample of the parameters shown in Table 7. The complete listing of all parameters and sub-parameters for the pickup truck and small car is shown in Appendix A. As an example, under Base Layout in Table 7, five systems were tested that had a ground mounted single post, and 1 of those systems was predicted to fail with a 50 to 100 percent chance of failure. The failure percentage was calculated to determine which sub-parameters had the highest rates of predicted failure.

Table 7. Predicted Chance of System Failures by Parameter

50-100% Chance of Failure	50-100% Chance of Failure Compared to No. of Systems	No. of Systems Tested	(mm)	(in)
Base Layout				
1	20%	5	Ground mounted single post	
0	0%	1	H dual upright	
2	22%	9	H single upright	
17	61%	28	Parallel dual upright	
0	0%	9	Parallel dual upright w/braces	
0	0%	2	Rubberbase	
0	0%	2	Skid-mounted	
0	0%	6	Tripod	
32	28%	113	X	
52	30%	175	Total	
Base Type				
16	34%	47	Double vertical spring	
1	8%	12	Extension spring	
1	20%	5	Ground mounted	
5	31%	16	Mast slides into base	
14	47%	30	Mast slides over base	
0	0%	16	Rigid	
4	100%	4	Slipbase	
0	0%	2	Rubberbase connector	
11	30%	37	Torsion spring	
0	0%	6	Tripod	
52	30%	175	Total	
Height to Bottom of Sign			(mm)	(in)
5	13%	39	305	12
7	24%	29	380	15
10	28%	36	460	18
2	33%	6	600	24
1	20%	5	740	29
2	25%	8	915	36
1	100%	1	1245	49
20	54%	37	1525	60
4	31%	13	2135	84
0	0%	1	none	
52	30%	175	Total	

4.1.1 Initial Analysis

Only those systems with a 50-100% chance of failure and a critical method of failure were considered. These systems were deemed to be the most critical for failure. Of the sub-parameters shown in Tables A-1 and A-2, sub-parameters were eliminated if they had no, or a very small, chance of failure. If the failure percentage of each sub-parameter was 25% or greater, the sub-parameter was still considered. Many sub-parameters remained after analyzing this condition, so the failure percentage was increased to 35%, 45%, 50%, and 60% to determine which specific sub-parameters were predicted to cause the most failures. Increasing the failure percentage level left only a few sub-parameters that were predicted to cause failure, but it also eliminated sub-parameters with large data sets, which reduced the accuracy of the analysis. Decreasing the failure percentage of sub-parameters did not eliminate enough sub-parameters to be able to sort through all combinations of sub-parameters. Trying to choose a system based on individual parameters was nearly impossible, since some sub-parameters were mutually exclusive.

This methodology provided useful information but was not very practical for selecting an existing system. First, the system parameters were considered independently, when in reality, it is likely that combinations of parameters cause failures. Consequently, even with the list of sub-parameters that had a high rate of predicted failure, it was difficult to define a system based on these parameters. Second, it was hard to develop a method for choosing the failure percentage level at which each sub-parameter should be evaluated. Increasing the level eliminated sub-parameters with large data sets, which reduces the accuracy and eliminates the most common systems. Even when examining sub-parameters that were predicted to fail 25% of the time, there were too many parameters to analyze all possible combinations.

4.1.2 Final Analysis

Another methodology was applied to determine the importance of system parameters. If a sub-parameter corresponded with 50 percent or more of predicted critical system failures for either vehicle, then its associated parameter was designated “important.” If a parameter was important for the predicted failure of both the small car and the truck, then it was designated “most important.”

Parameters that were most important were sign panel material, height to the top of the mast, mast stages, mast material, flag staff material, and system orientation. Important parameters for the small car were height to the top of the flags and sign-locking mechanism. The only important parameter for the truck was base layout. All other system parameters were considered to be unimportant.

For the pickup truck, specific sub-parameters were considered critical for causing system failure when combined with other sub-parameters. The critical range for the top mast height was 75 to 132 in. (1,905 to 3,353 mm). Further, failure was more likely to occur for a system configured with a 2-staged, steel mast and an aluminum sign panel. The use of wood-dowel flag staffs as well as the nonuse of flags were also critical, and the 0-degree system orientation was deemed critical for failure. X-footprint sign systems were critical for failure with the pickup truck.

For the small car, specific sub-parameters were considered critical when combined with other parameters. The critical range for the top mast height was 59 to 110 in. (1,499 to 2,794 mm). For the small car, failure was also found to be more likely to occur for a system configured with a 2-staged, steel mast and an aluminum sign panel. A no flags configuration was also

critical, and the 0-degree system orientation was critical for failure. A sign locking mechanism consisting of a nut and bolt connection was also critical for failure with the small car.

4.2 System Analysis

Separate analyses were conducted for system impacts with the small car and pickup truck. For the pickup truck, only those systems which passed the NCHRP Report No. 350 criteria but were predicted to fail the MASH guidelines were included. For the small car, those systems which passed and failed the NCHRP Report No. 350 criteria but were predicted to fail the MASH guidelines were included. Only two systems were predicted to fail the MASH small car test after actually passing NCHRP Report No. 350.

To determine specific systems that had a higher rate of a critical failure, systems were analyzed based on the importance of parameters. For each vehicle, systems with a predicted critical failure were sorted by combinations of three “most important” and “important” parameters. All combinations consisted of sub-parameters with the highest rates of predicted failure and were critical for predicted failure with the MASH criteria. An example of this analysis is shown in the flowcharts in Figures 5 through 8. All of the system combinations that were determined to be critical are shown in Table 8.

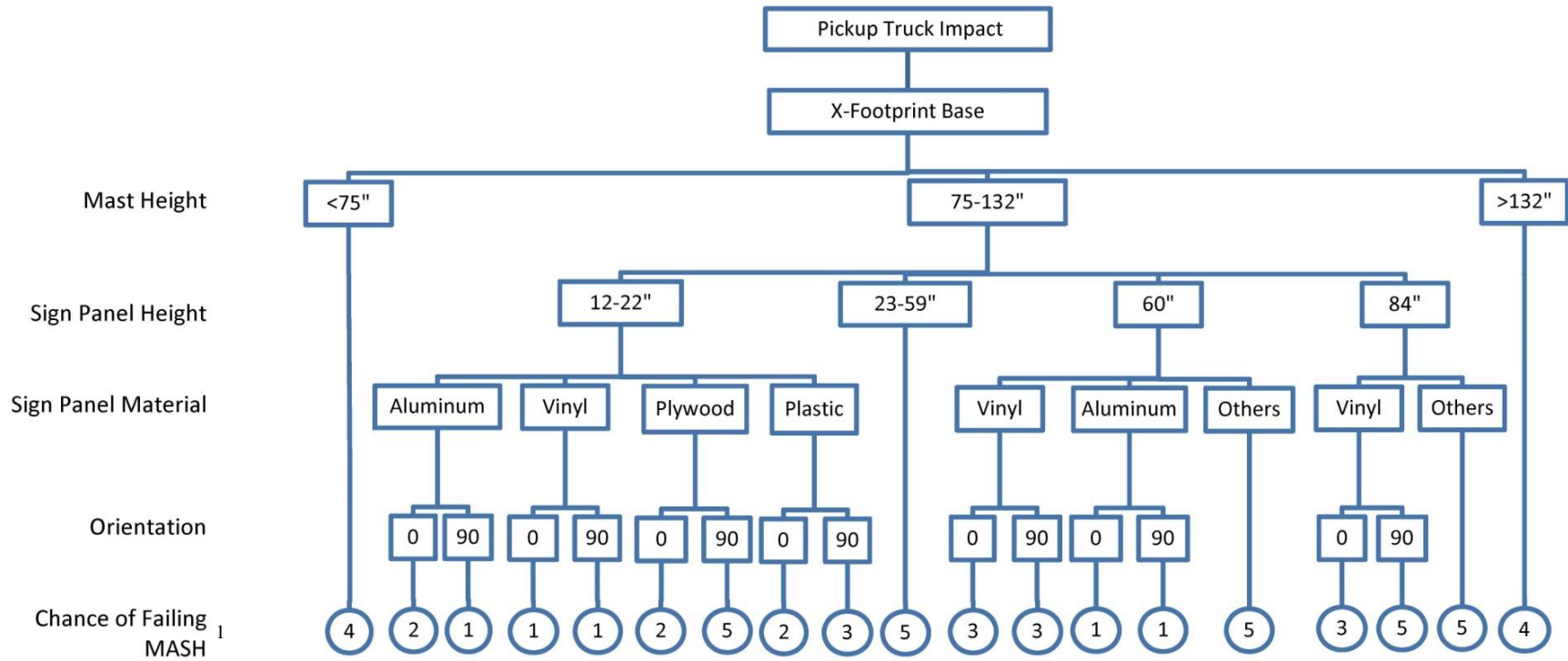

¹Chance of Failing MASH: 1 - 75 to 100%, 2 - 50 to 75%, 3 - 25 to 50%, 4 - 0 to 25%, 5 - Unknown

Figure 5. TL-3 MASH Impact Prediction with Pickup Truck – X-footprint Base

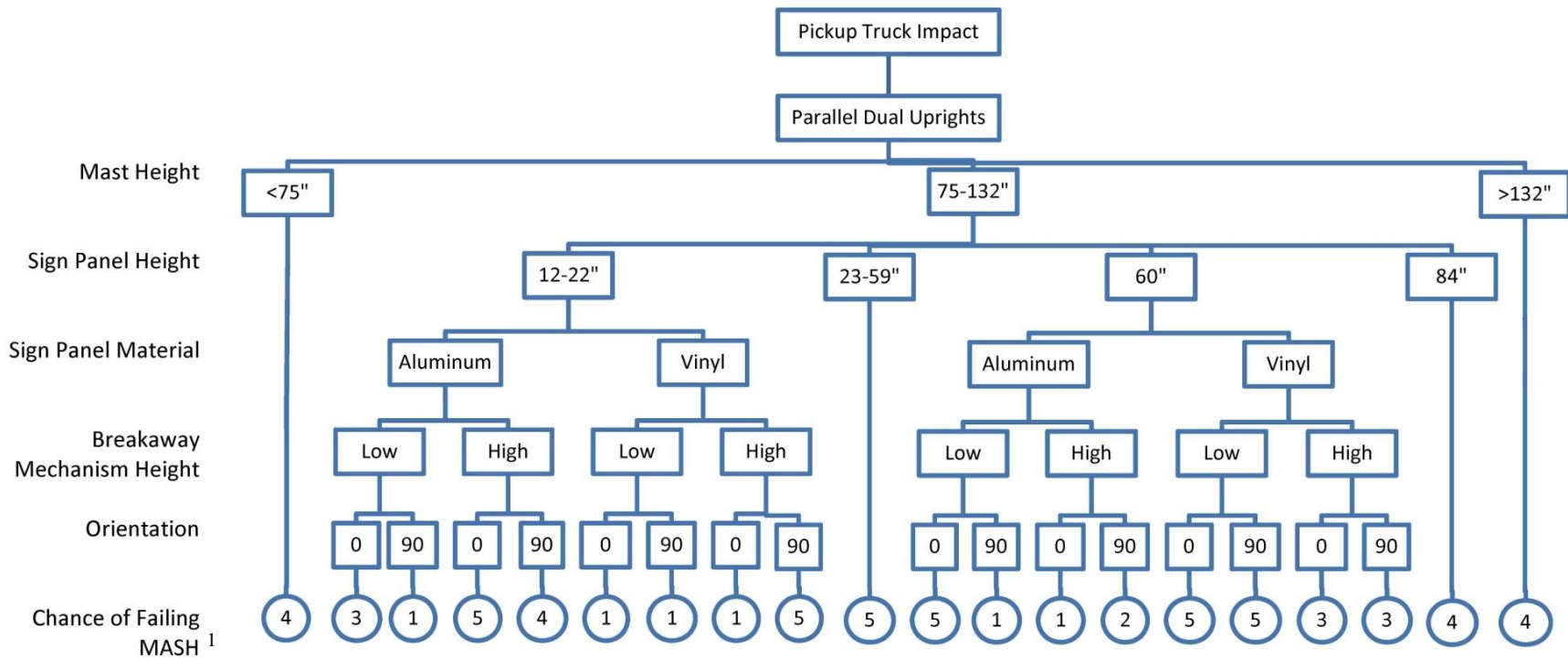

¹Chance of Failing MASH: 1 - 75 to 100%, 2 - 50 to 75%, 3 - 25 to 50%, 4 - 0 to 25%, 5 - Unknown

Figure 6. TL-3 MASH Impact Prediction with Pickup Truck – Parallel Dual Uprights

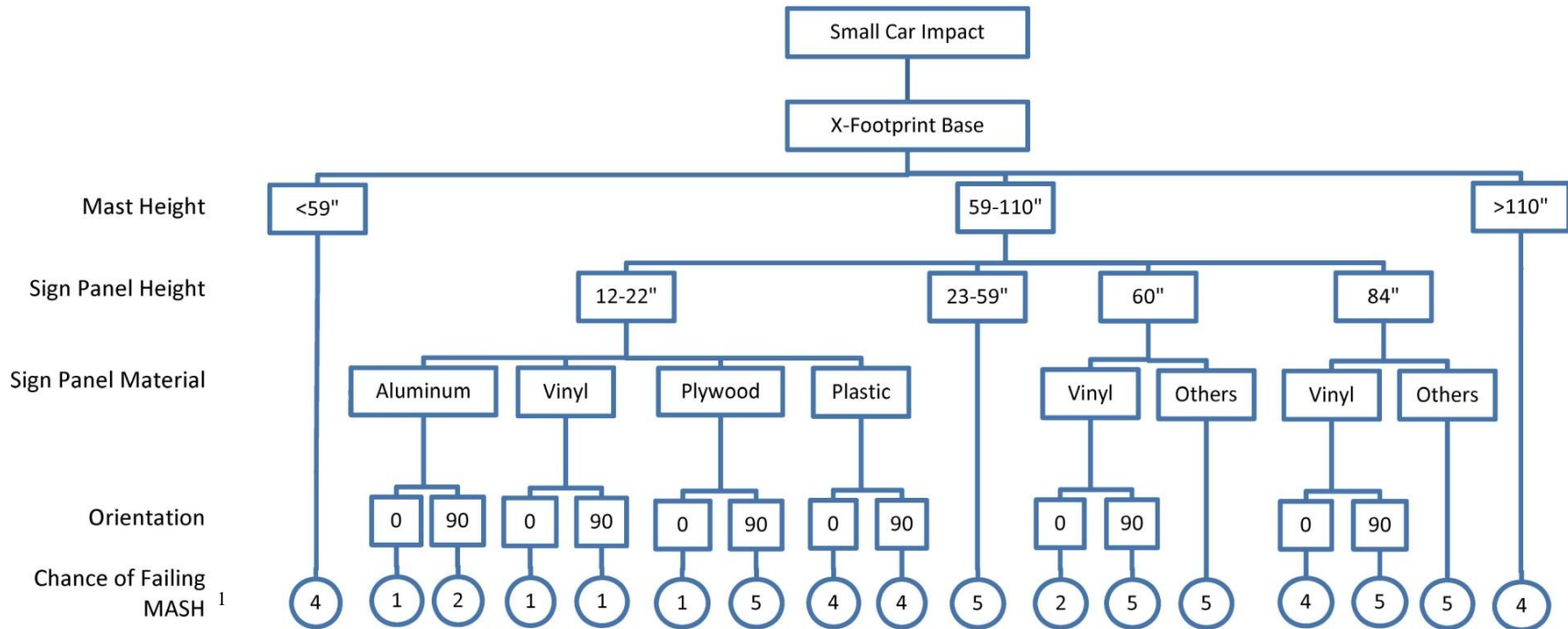

¹Chance of Failing MASH: 1 - 75 to 100%, 2 - 50 to 75%, 3 - 25 to 50%, 4 - 0 to 25%, 5 - Unknown

Figure 7. TL-3 MASH Impact Prediction with Small Car – X-footprint Base

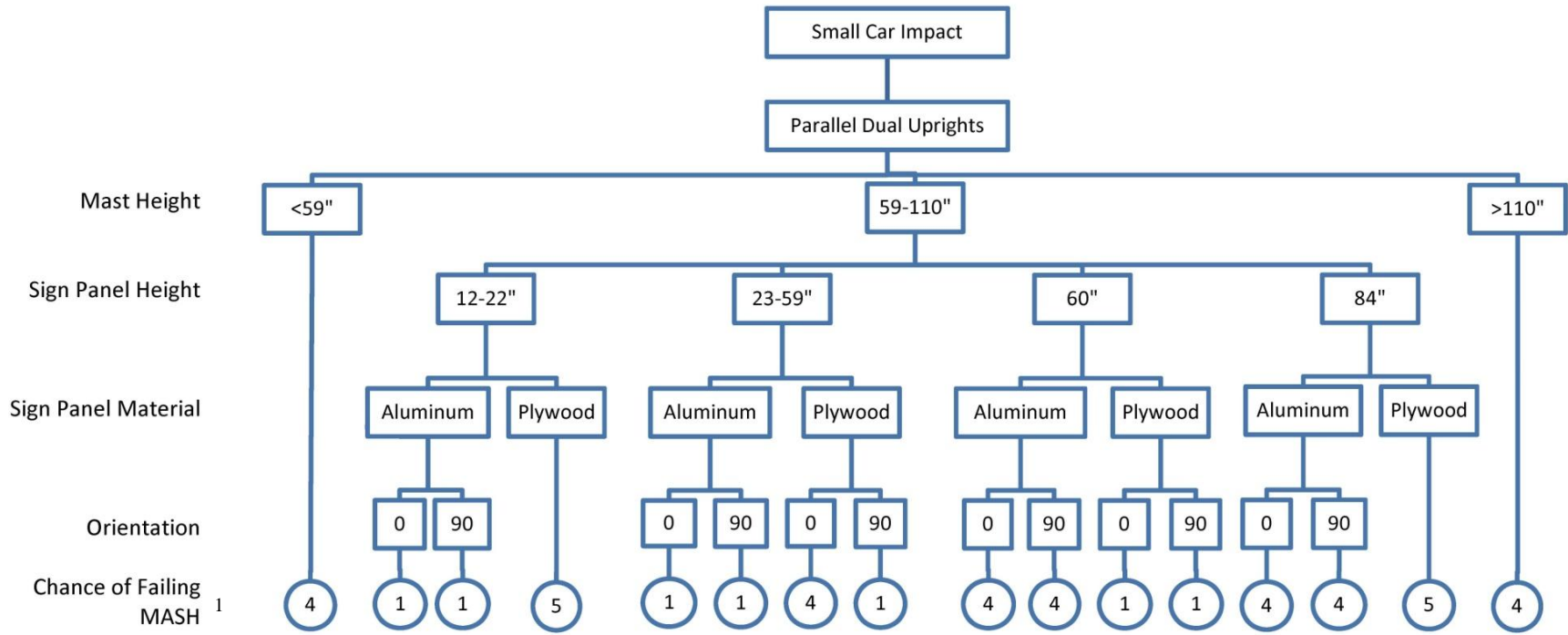

¹Chance of Failing MASH: 1 - 75 to 100%, 2 - 50 to 75%, 3 - 25 to 50%, 4 - 0 to 25%, 5 - Unknown

Figure 8. TL-3 MASH Impact Prediction with Small Car – Parallel Dual Uprights

4.3 System Selection

The work-zone systems shown in Table 8 included all of the devices under consideration for full-scale crash testing. However, it should be noted that these configurations were based on the test data obtained from prior MwRSF impact tests as well as the subsequent analyses. Since the small car analysis was conducted on systems that had passed and failed NCHRP Report No. 350, similar systems that were FHWA-accepted and exist in the marketplace were sought out. Small system parameter changes can significantly change its safety performance. Thus, similar systems with some of the same parameters could perform better or worse than the predicted performance of the baseline device. For this study, it was assumed that systems with most of the same important parameters should have similar performance.

The final portable sign support systems for use in the full-scale crash testing program were chosen in conjunction with the FHWA. Due to limitations on the different types of portable sign support systems tested at MwRSF, the FHWA recommended additional portable sign support systems that incorporated some of the “most important” system parameters and those that were believed to be critical for failure with either the small car or pickup truck vehicles. All of the systems that were selected for MASH testing had also been successfully crash tested to NCHRP Report No. 350 and accepted by the FHWA. Since the objective was not to obtain system approval using the MASH evaluation criteria, it was unnecessary to test the same system at both the 0- and the 90-degree orientations or with both the small car and pickup truck vehicles, as required in MASH.

Table 8. Recommended Portable Sign Support Systems for Testing

PICKUP TRUCK RECOMMENDED SYSTEMS	SMALL CAR RECOMMENDED SYSTEMS
<ul style="list-style-type: none"> • X-stand, double vertical spring, top of mast 90 in. (2,286 mm), bottom of sign 18 in. (457 mm), flags, vinyl or aluminum panel, 0° or 90° 	<ul style="list-style-type: none"> • X-stand, double vertical spring, top of mast 94 in. (2,388 mm), bottom of sign 18 in. (457 mm), flags, aluminum or vinyl panel, 0°
<ul style="list-style-type: none"> • Parallel dual upright, top of mast 86 in. (2,184 mm), bottom of sign 15-24 in. (381-610 mm), no flags, aluminum panel, 0° 	<ul style="list-style-type: none"> • Parallel dual upright, top of mast 84-108 in. (2,134-2,743 mm), bottom of sign 15-24 in. (381-610 mm), no flags, aluminum panel, 0° or 90°
<ul style="list-style-type: none"> • X-stand, torsion spring, top of mast 90 in. (2,286 mm), bottom of sign 12-18 in. (305-457 mm), flags, aluminum or vinyl panel, 0° 	<ul style="list-style-type: none"> • X-stand, torsion spring, top of mast 90 in. (2,286 mm), bottom of sign 12-15 in. (305-381 mm), flags, vinyl panel, 0° or 90°
<ul style="list-style-type: none"> • X-stand, double vertical spring, top of mast 130 in. (3,302 mm), bottom of sign 60 in. (1,524 mm), flags, aluminum panel, 90° 	<ul style="list-style-type: none"> • X-stand, rigid base, no mast, bottom of sign 18 in. (457 mm), flags, vinyl panel with aluminum crossbracing, 0°
<ul style="list-style-type: none"> • Parallel dual upright, top of mast 130 in. (3,302 mm), bottom of sign 60 in. (1,524 mm), no flags, aluminum panel, 90° 	<ul style="list-style-type: none"> • Parallel dual upright, top of mast 60-83 in. (1,524-2,108 mm), bottom of sign 18-36 in. (457-914 mm), no flags, aluminum panel, 0°
<ul style="list-style-type: none"> • X-stand, slipbase, top of mast 130 in. (3,302 mm), bottom of sign 60 in. (1,524 mm), flags, aluminum panel, 0° or 90° 	

The research conducted herein was not comprehensive of all work-zone traffic control devices and therefore, cannot be used to predict acceptance nor failure of a particular work-zone sign support system. The methodology utilized for categorizing and sorting the work-zone systems was specifically tailored to a specific sub-set of systems and for use in the testing for this project. It should be noted that there are other existing work-zone systems not analyzed in this study that would also be critical for failure under the MASH evaluation criteria.

5 WORK-ZONE SIGN SUPPORT SYSTEMS

A total of eight work-zone traffic control devices were crash tested under this study, as described below. The crash tests were all conducted on prior FHWA-accepted, NCHRP Report No. 350-crashworthy, portable sign support systems. All materials for the work-zone traffic control devices were purchased through suppliers.

The eight portable sign support systems included:

1. (System No. 1A – Test Designation No. 3-72) A double-upright coil, spring-mounted sign support with a 48-in. x 48-in. (1,219-mm x 1,219-mm) diamond-shaped aluminum sign panel mounted at a height of $59^{15}/_{16}$ in. (1,522 mm) from the ground to the bottom of the sign panel and with three wood-dowel flags mounted at a height of $135^{5}/_{16}$ in. (3,437 mm) from the ground to the top of the mast.
2. (System No. 1B – Test Designation No. 3-72) A $25^{7}/_{16}$ -in. wide x 72-in. deep x $109^{7}/_{8}$ -in. tall (646-mm x 1,829-mm x 2,791-mm) dual parallel uprights sign support with a 48-in. x 48-in. (1,219-mm x 1,219-mm) diamond-shaped aluminum sign panel mounted at a height of $61^{5}/_{8}$ in. (1,565 mm) from the ground to the bottom of the sign panel and with one warning light mounted at a height of $109^{7}/_{8}$ in. (2,791 mm).
3. (System No. 2A – Test Designation No. 3-71) A double-upright coil, spring-mounted sign support with a 48-in. x 48-in. (1,219-mm x 1,219-mm) diamond-shaped aluminum sign panel mounted at a height of $20^{1}/_{8}$ in. (511 mm) from the ground to the bottom of the sign panel and with three wood-dowel flags mounted at a height of $88^{1}/_{2}$ in. (2,248 mm) from the ground to the top of the mast.
4. (System No. 2B – Test Designation No. 3-71) A tripod-mounted portable sign support with a 48-in. x 48-in. (1,219-mm x 1,219-mm) diamond-shaped aluminum sign panel mounted at a height of $14^{11}/_{16}$ in. (373 mm) from the ground to the bottom of the sign panel and with two wood-dowel flags mounted at a height of 72 in. (1,829 mm) from the ground to the top of the sign panel.
5. (System No. 3A – Test Designation No. 3-71) A double-upright coil, spring-mounted sign support with a 48-in. x 48-in. (1,219-mm x 1,219-mm) diamond-shaped aluminum sign panel mounted at a height of 18 in. (457 mm) from the ground to the bottom of the sign panel and with three wood-dowel flags mounted at a height of 89 in. (2,261 mm) from the ground to the top of the mast.

6. (System No. 3B – Test Designation No. 3-71) A dual-extension, spring-mounted sign support with a 48-in. x 48-in. (1,219-mm x 1,219-mm) diamond-shaped vinyl roll-up sign panel mounted at a height of 21 in. (533 mm) from the ground to the bottom of the sign panel and with two wood-dowel flags mounted at a height of 90½ in. (2,299 mm) from the ground to the top of the mast.
7. (System No. 4A – Test Designation No. 3-72) A double-upright coil, spring-mounted sign support with a 48-in. x 48-in. (1,219-mm x 1,219-mm) diamond-shaped vinyl roll-up sign panel mounted at a height of 13¾ in. (340 mm) from the ground to the bottom of the sign panel and with three wood-dowel flags mounted at a height of 92⁵/₁₆ in. (2,345 mm) from the ground to the top of the mast.
8. (System No. 4B – Test Designation No. 3-72) A double-upright coil, spring-mounted sign support with a 48-in. x 48-in. (1,219-mm x 1,219-mm) diamond-shaped aluminum sign panel mounted at a height of 14¹⁵/₁₆ in. (379 mm) from the ground to the bottom of the sign panel and with three wood-dowel flags mounted at a height of 100¹¹/₁₆ in. (2,557 mm) from the ground to the top of the mast.

A list of the eight crash tests and associated systems is provided in Table 9.

Table 9. List of Crash Tests

WORK-ZONE TRAFFIC CONTROL DEVICES		
Portable Sign Support Systems		
Test No.	System No.	Description
WZ09-1	1A	Double-Upright Coil, Spring-Mounted Sign Support, Aluminum Sign Panel, 90-Degree Impact with 2270P
WZ09-1	1B	Parallel Dual Uprights, Steel Sign Support, Aluminum Sign Panel, Amber Warning Light, Sandbag on Each Leg, 90-Degree Impact with 2270P
WZ09-2	2A	Double-Upright Coil, Spring-Mounted Sign Support, Aluminum Sign Panel, 0-Degree Impact with 1100C
WZ09-2	2B	Tripod-Mounted Sign Support, Aluminum Sign Panel, 90-Degree Impact with 1100C
WZ09-3	3A	Double-Upright Coil, Spring-Mounted Sign Support, Roll-up Sign Panel, 0-Degree Impact with 2270P
WZ09-3	3B	Double-Upright Coil, Spring-Mounted Sign Support, Aluminum Sign Panel, 90-Degree Impact with 2270P
WZ09-4	4A	Double-Upright Coil, Spring-Mounted Sign Support, Aluminum Sign Panel, 0-Degree Impact with 1100C
WZ09-4	4B	Dual Extension, Spring-Mounted Sign Support, Roll-up Sign Panel, 90-Degree Impact with 1100C

For each test, two portable sign support systems were impacted with one vehicle. The two systems were longitudinally placed approximately 60 ft (18 m) apart and offset to impact the left- and right-front quarter points of the vehicle. The test layouts are shown in Figures 9 through 12. Selected material specifications, mill certifications, and certificates of conformity for the non-proprietary systems are shown in Appendix B. For the proprietary systems, these materials were not documented within this report and instead were retained in the project files. MwRSF researchers, in consultation with FHWA personnel, chose to not deliberately divulge the system names or manufacturers of the proprietary devices in order to reduce the propensity for the unapproved use of unsatisfactory test results.

5.1 Portable Sign Support Systems

The portable sign support system details are shown in Figures 13 through 28. The dimensional measurements of the portable sign support systems are found in Appendix C.

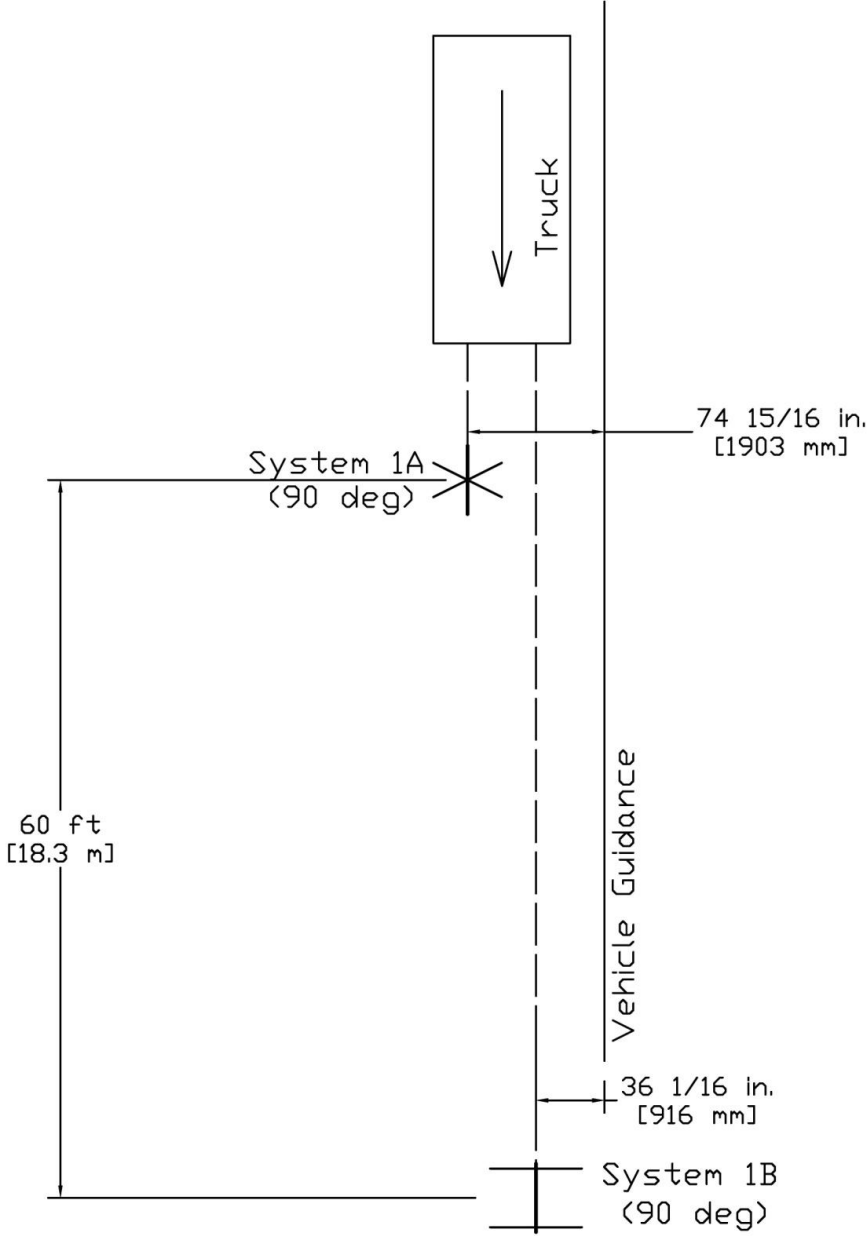

Figure 9. Test Layout, Test No. WZ09-1

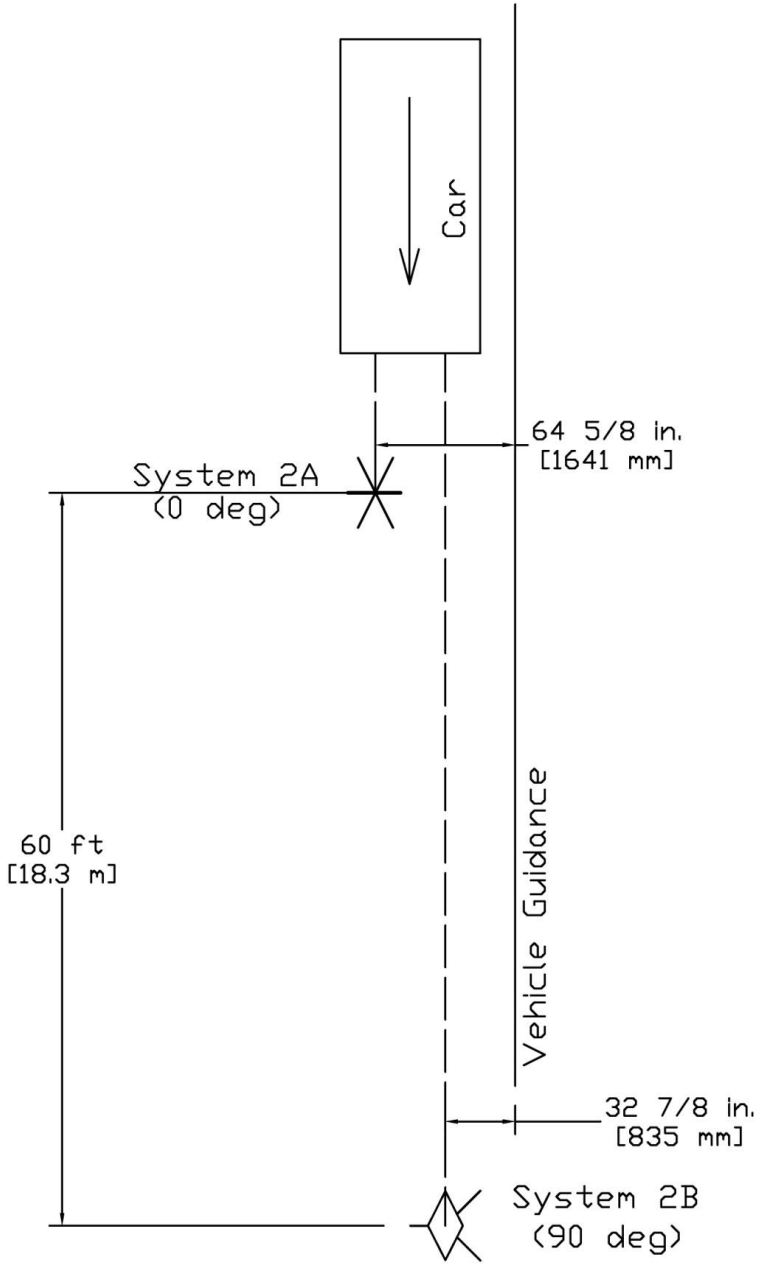

Figure 10. Test Layout, Test No. WZ09-2

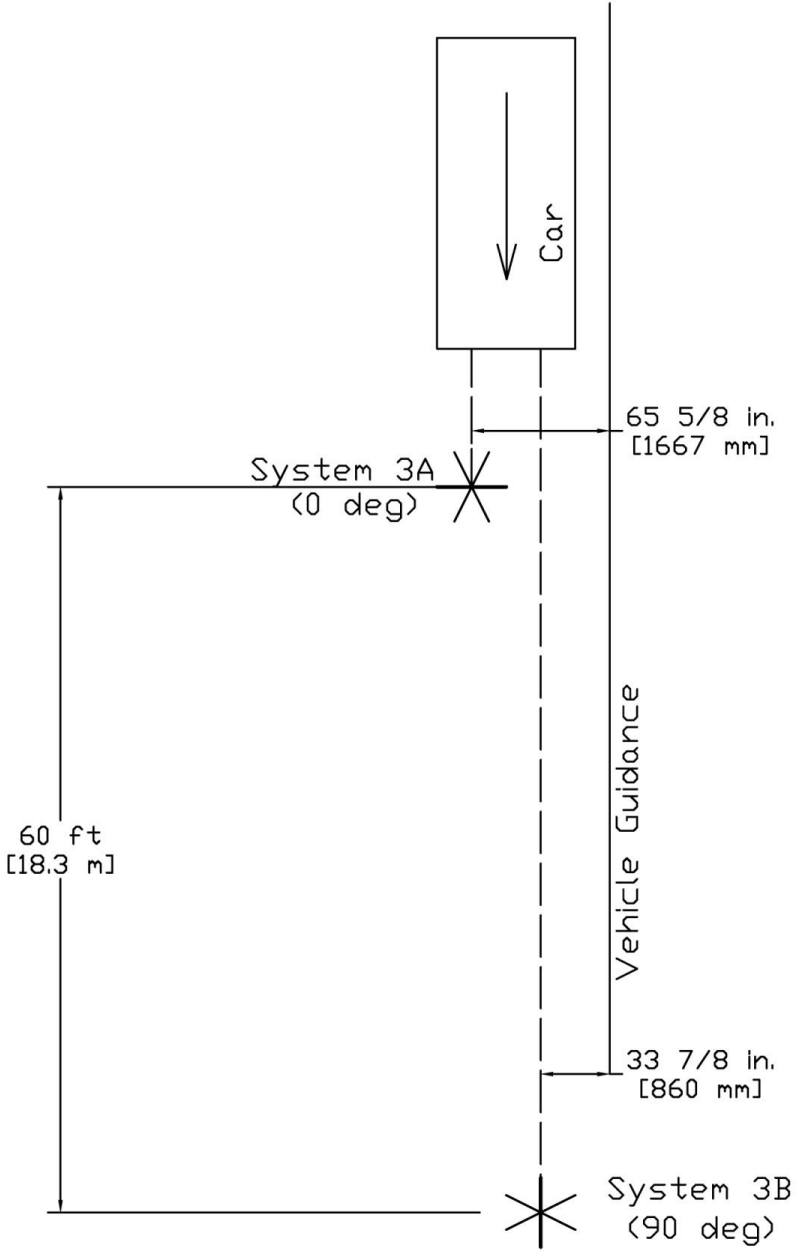

Figure 11. Test Layout, Test No. WZ09-3

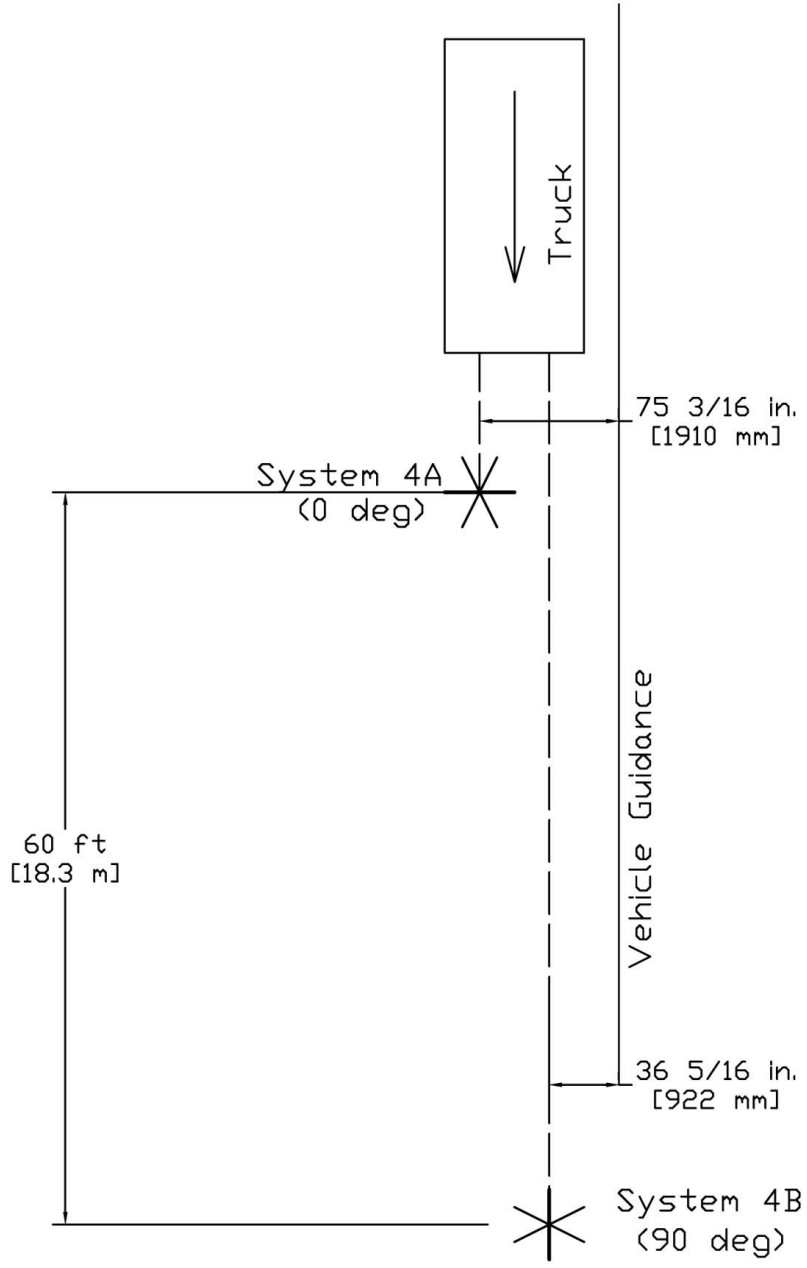

Figure 12. Test Layout, Test No. WZ09-4

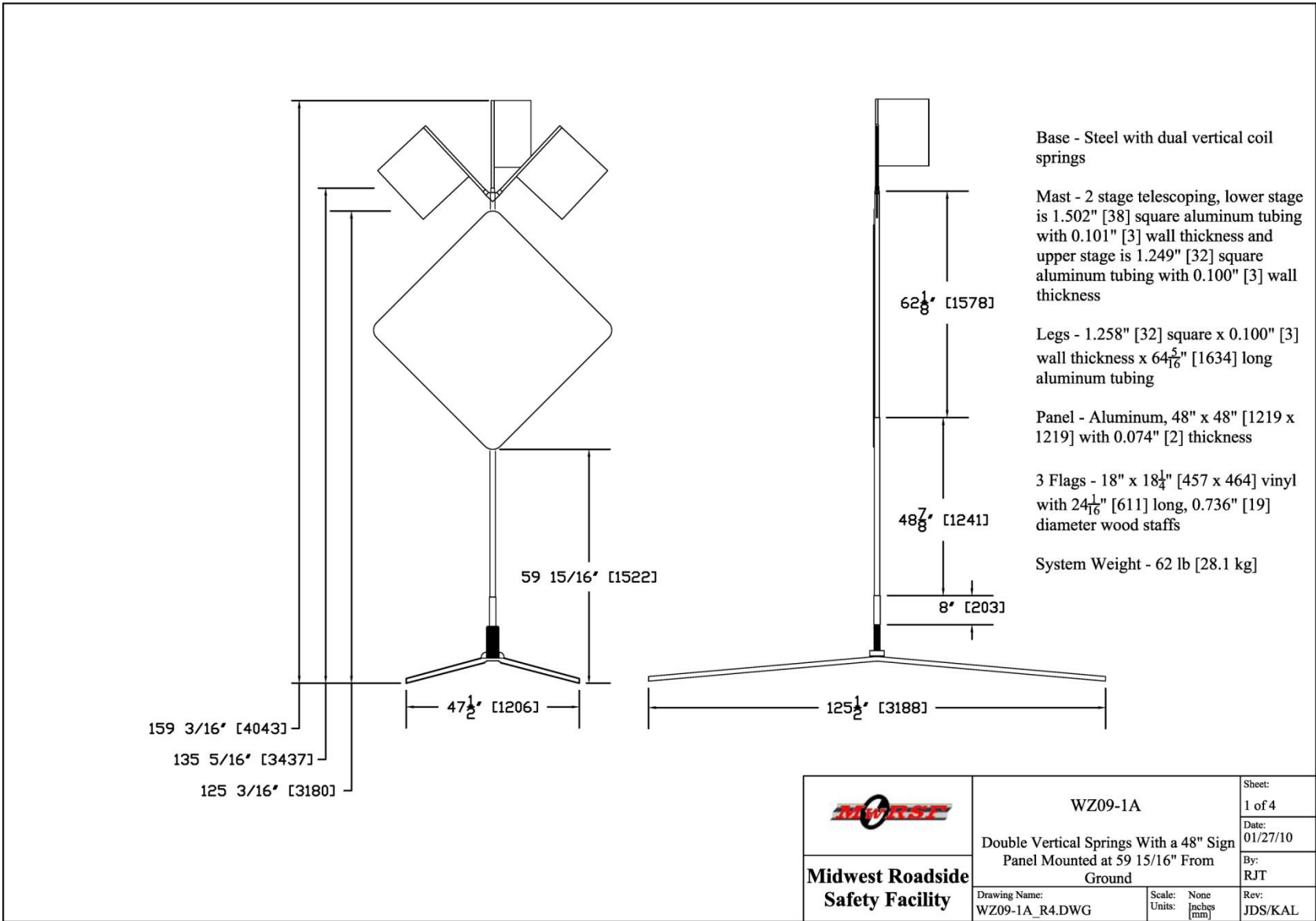
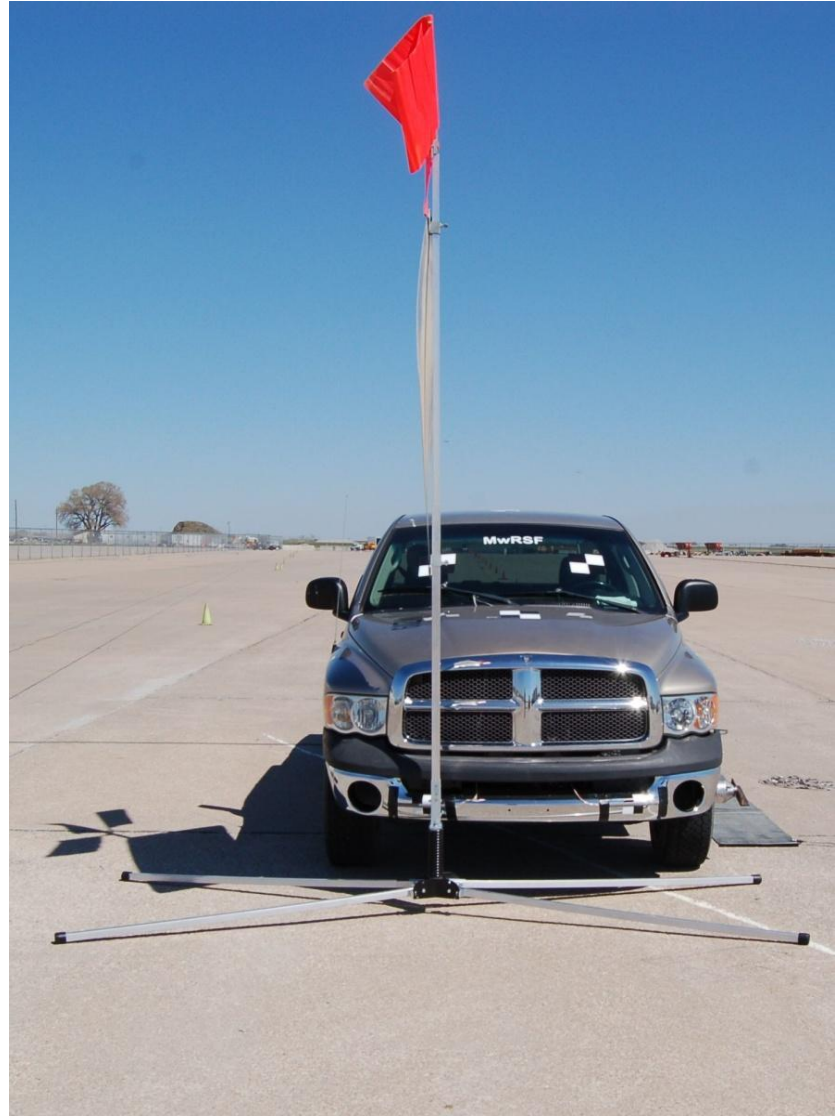

Figure 13. System No. 1A Details, Test No. WZ09-1



Figure 14. System No. 1A Details, Test No. WZ09-1



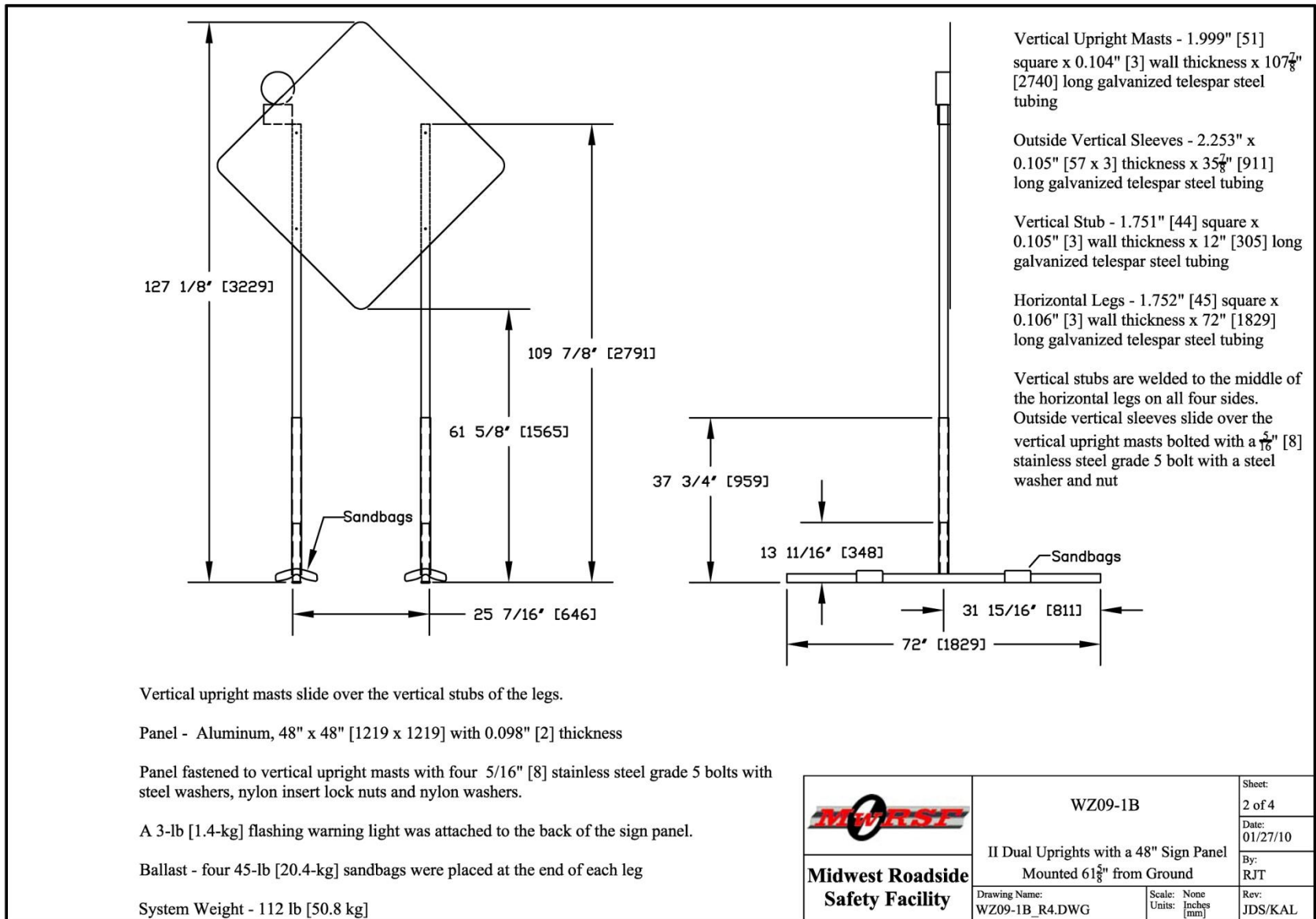

Figure 15. System No. 1B Details, Test No. WZ09-1



Figure 16. System No. 1B Details, Test No. WZ09-1

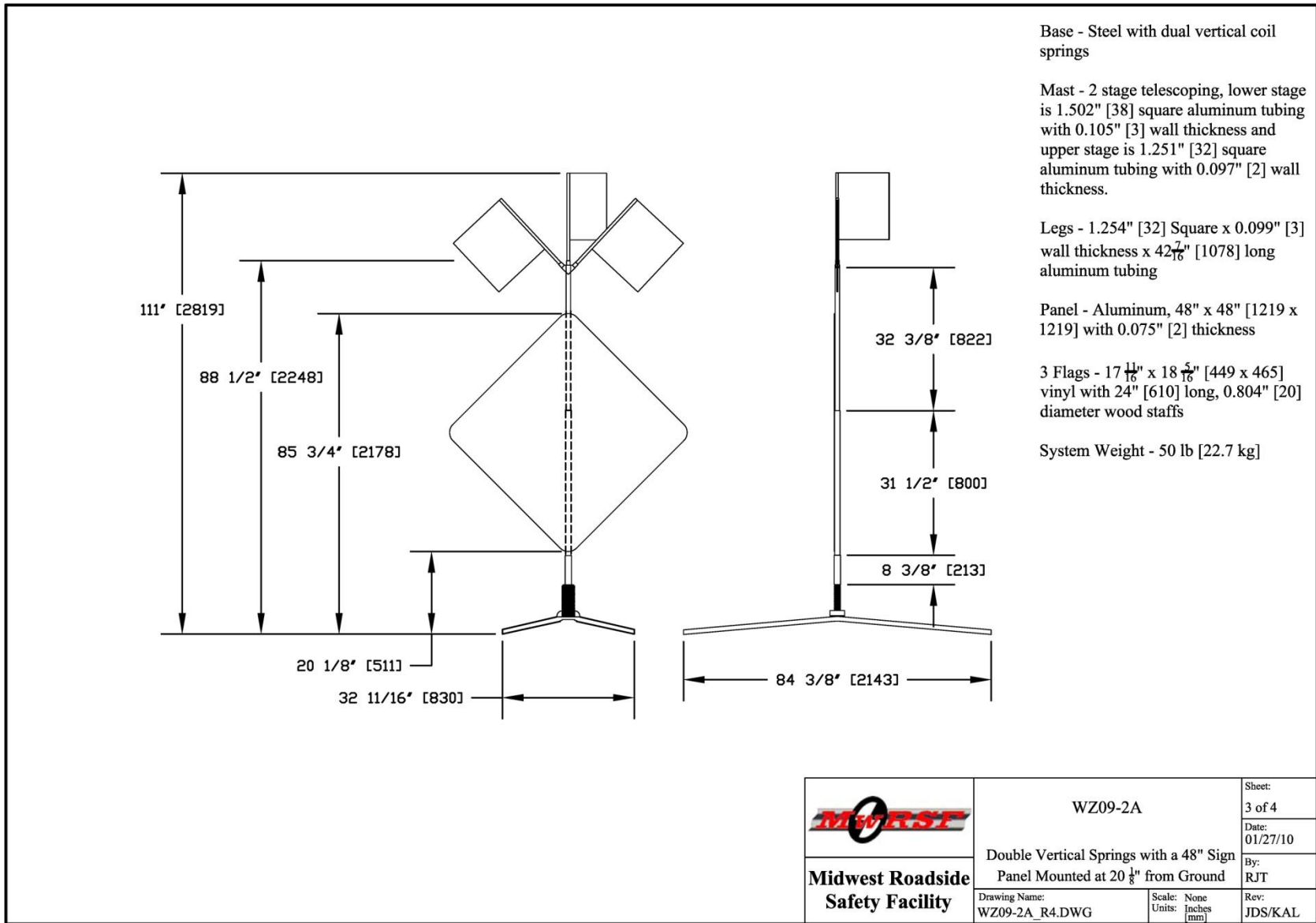
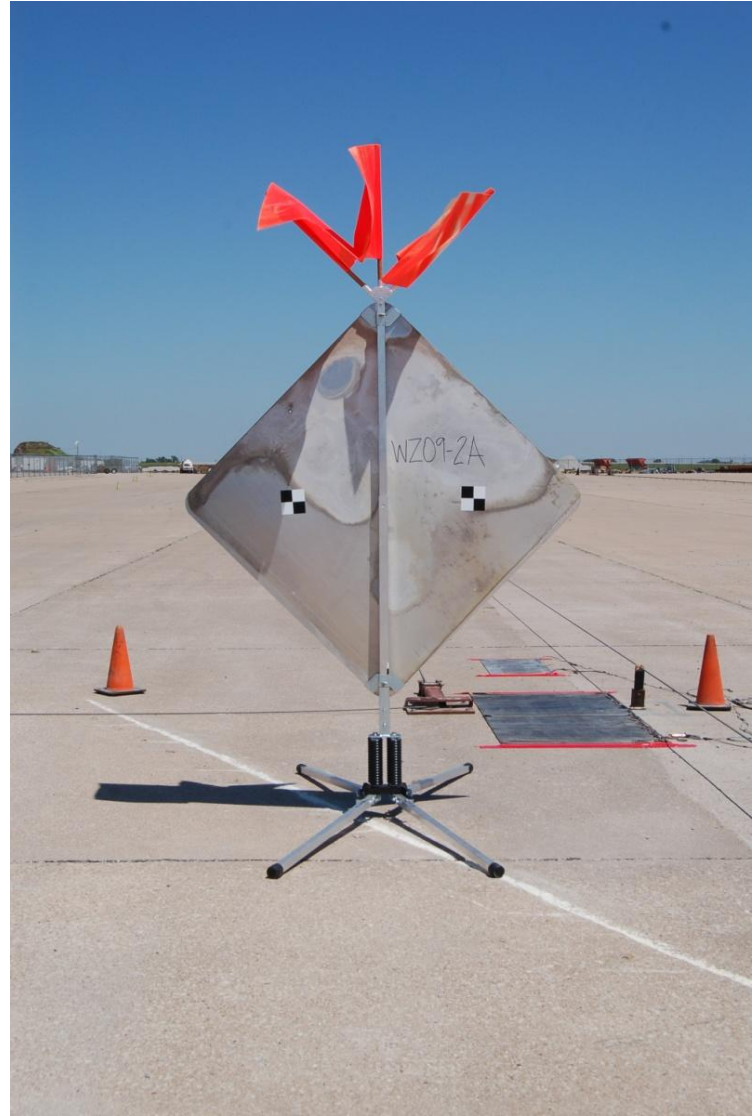

Figure 17. System No. 2A Details, Test No. WZ09-2



Figure 18. System No. 2A Details, Test No. WZ09-2



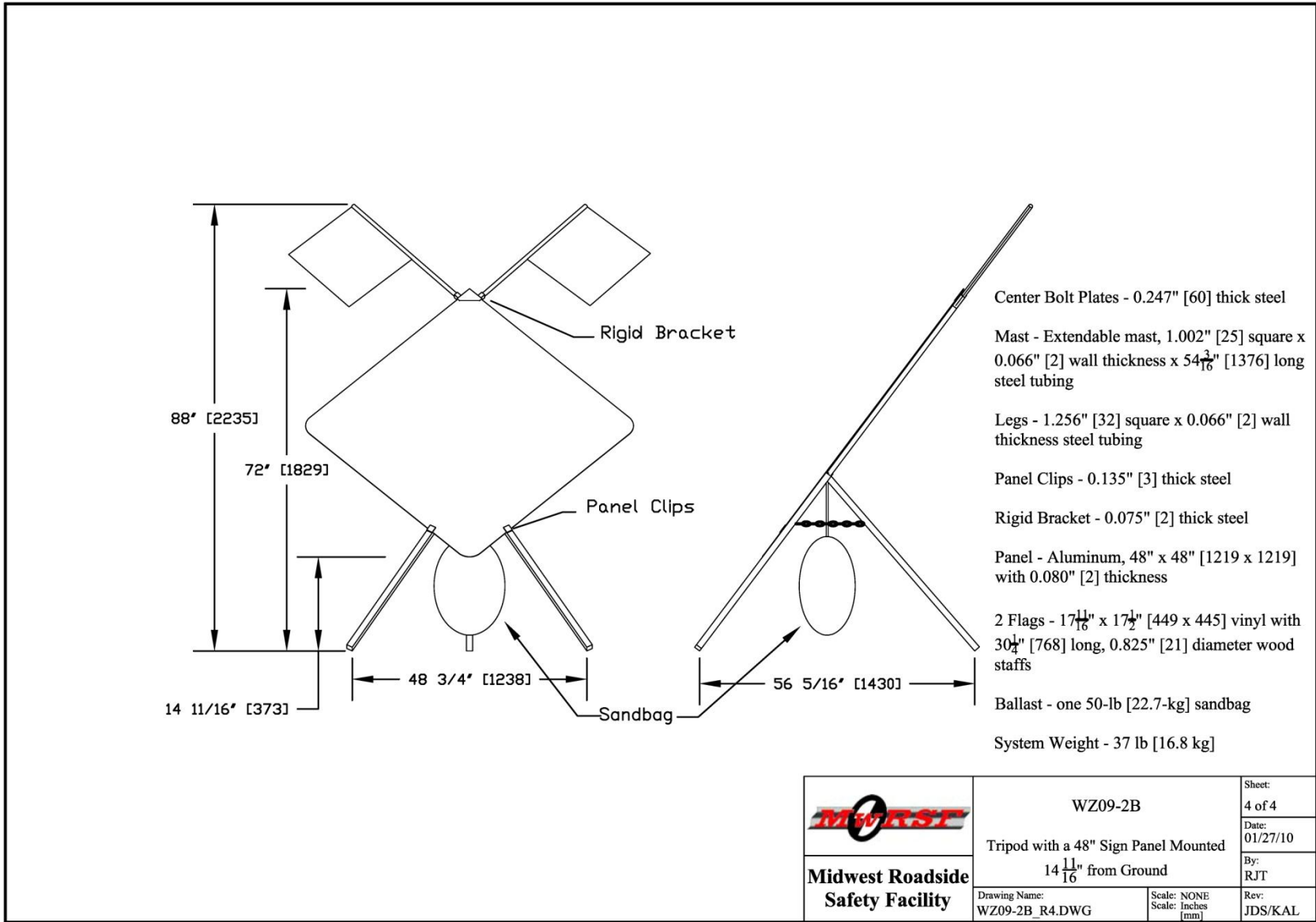

Figure 19. System No. 2B Details, Test No. WZ09-2

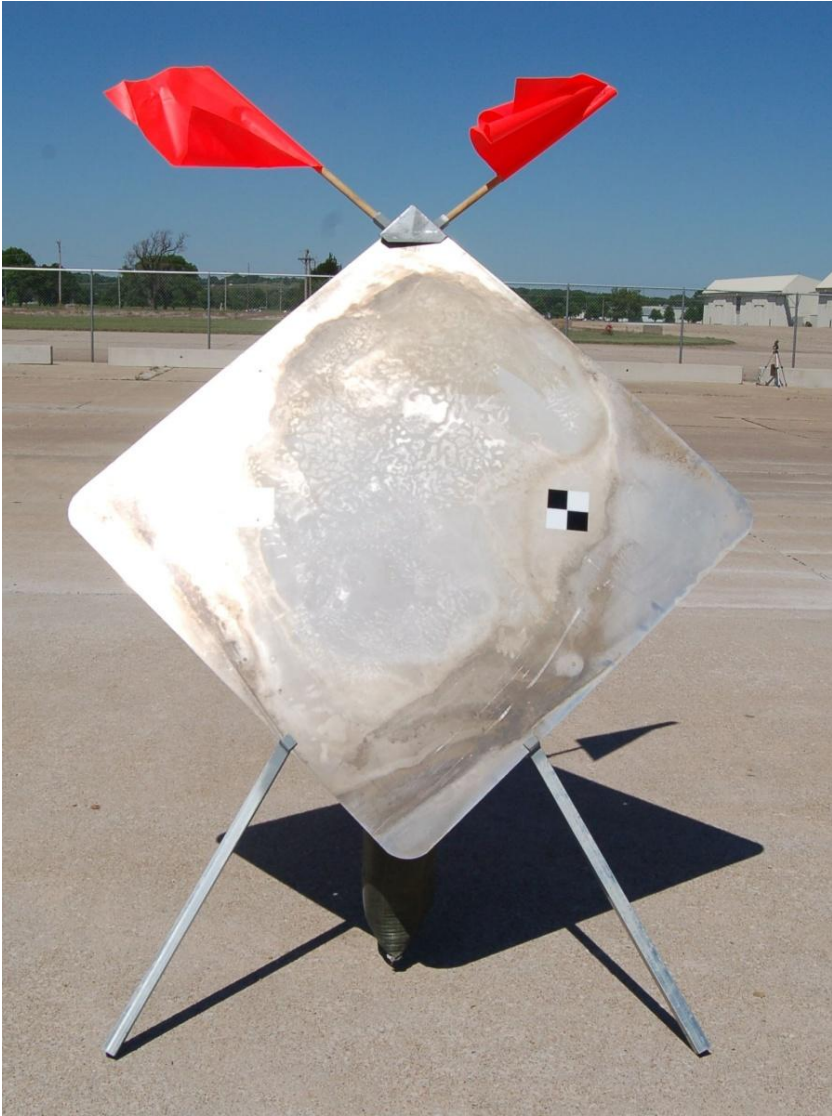

Figure 20. System No. 2B Details, Test No. WZ09-2



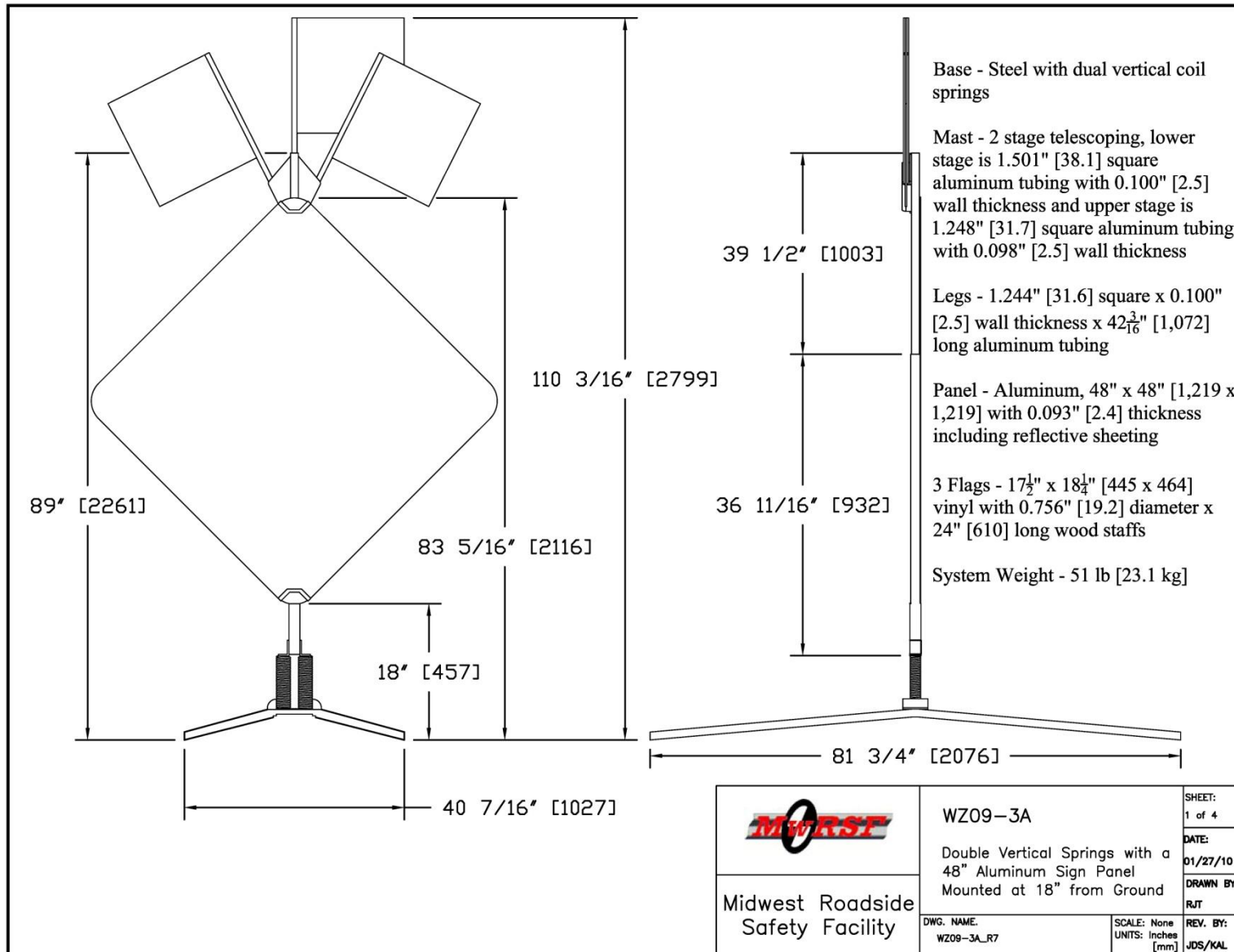

Figure 21. System No. 3A Details, Test No. WZ09-3



Figure 22. System No. 3A Details, Test No. WZ09-3



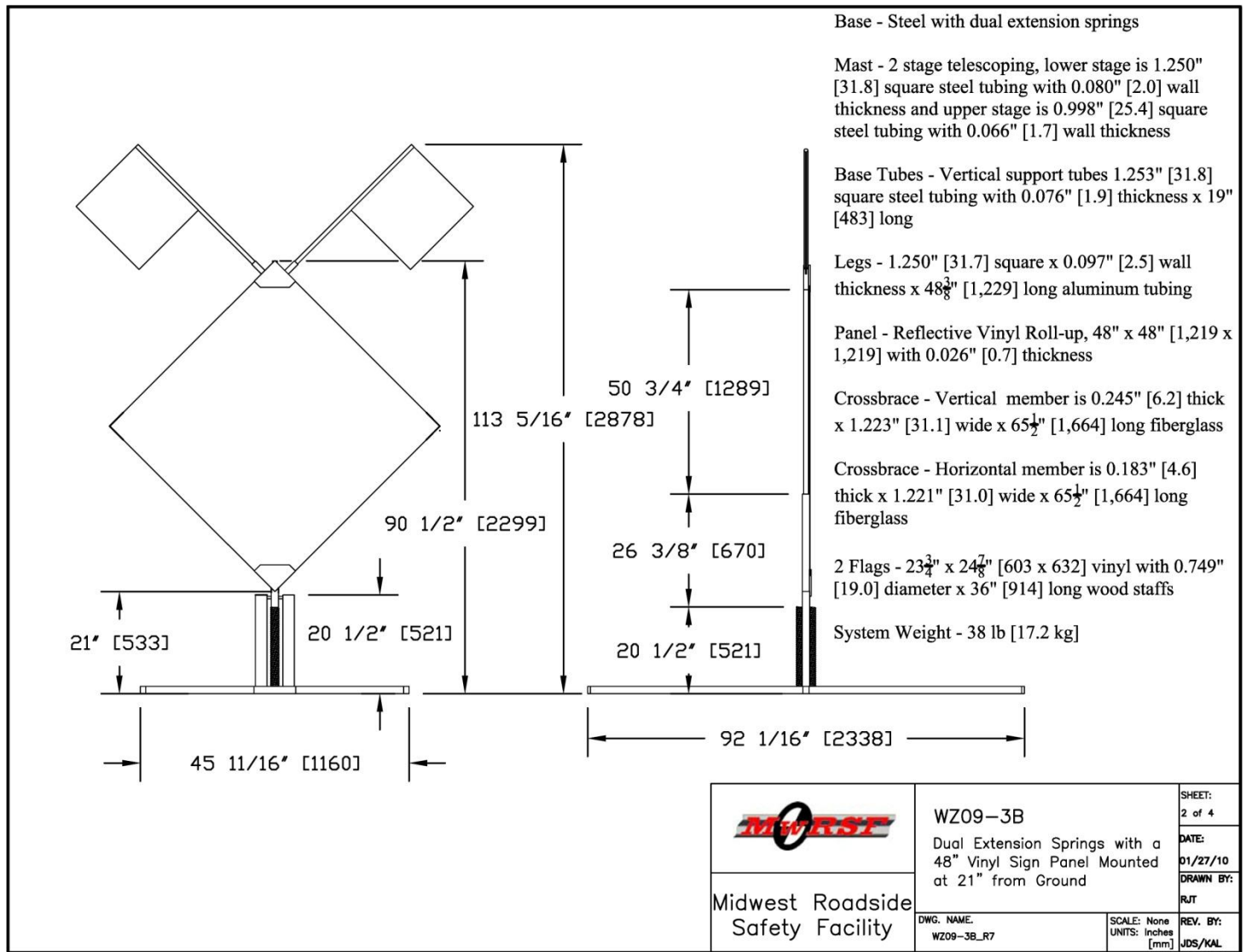

Figure 23. System No. 3B Details, Test No. WZ09-3



Figure 24. System No. 3B Details, Test No. WZ09-3



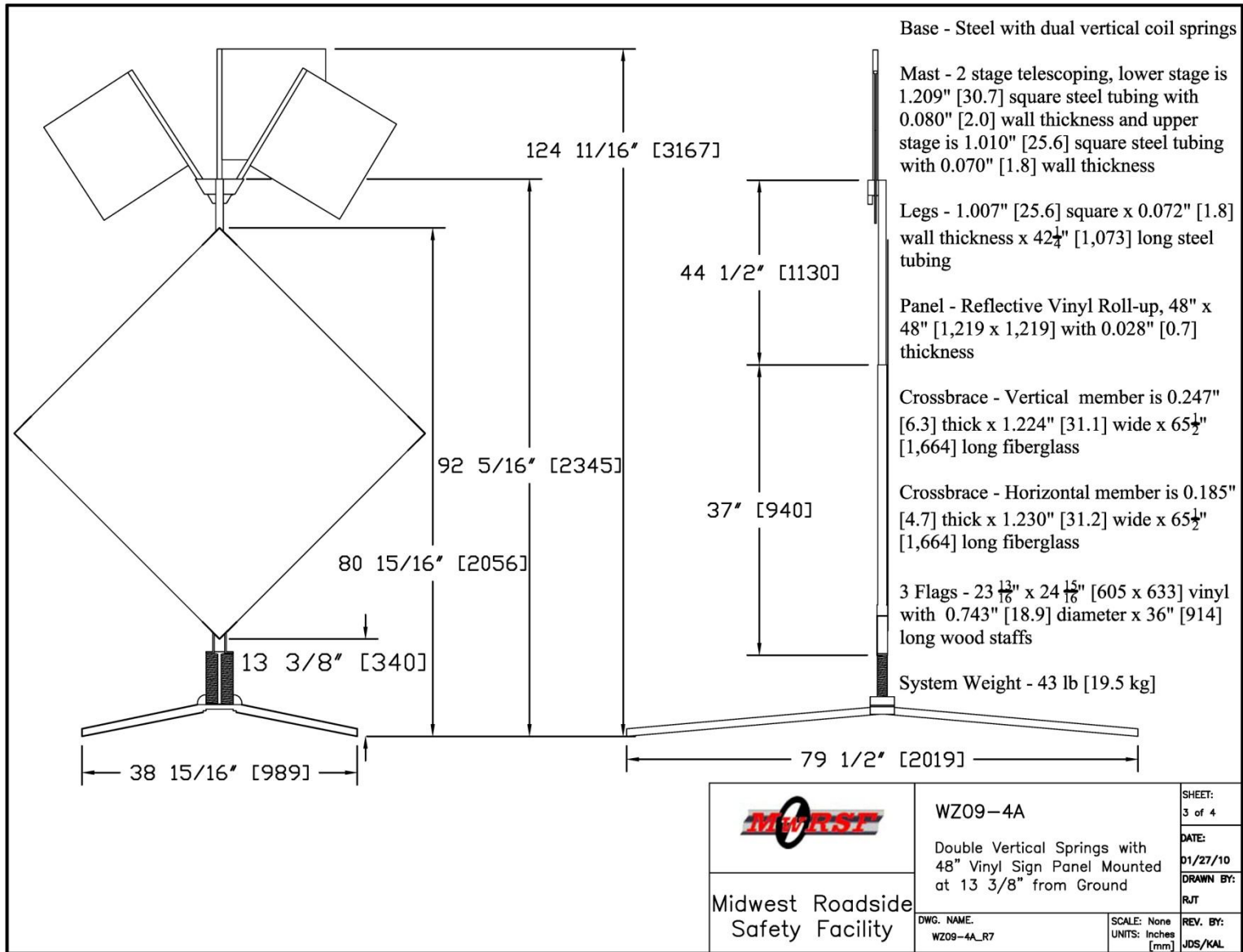

Figure 25. System No. 4A Details, Test No. WZ09-4



Figure 26. System No. 4A Details, Test No. WZ09-4



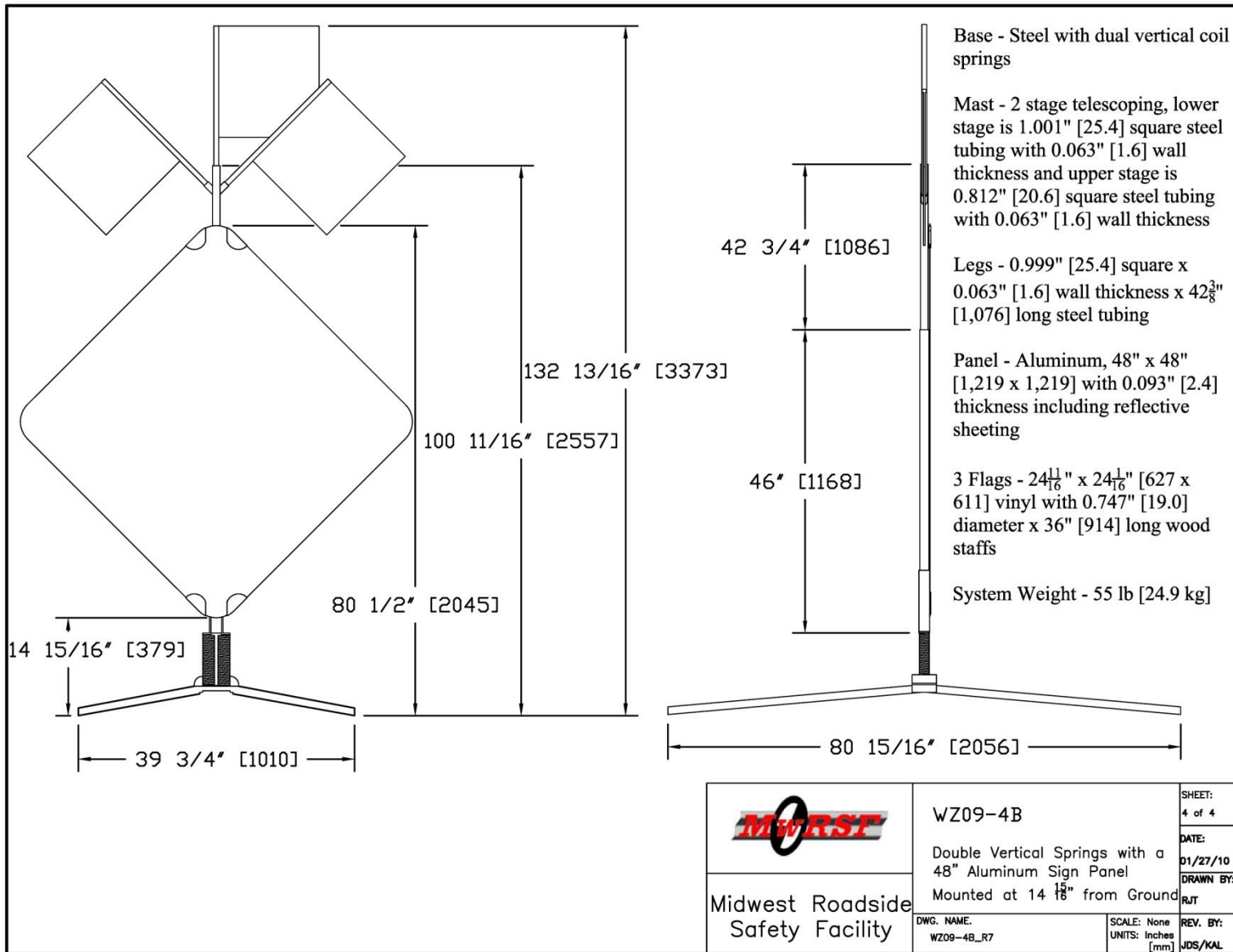

Figure 27. System No. 4B Details, Test No. WZ09-4



Figure 28. System No. 4B Details, Test No. WZ09-4



6 TEST REQUIREMENTS AND EVALUATION CRITERIA

6.1 Test Requirements

Any newly purchased work-zone traffic control devices, such as portable sign supports, must satisfy impact safety standards provided in MASH [27] in order to be accepted by the FHWA for use along the NHS. According to FHWA's Submission Guidelines attached to the July 1997 memorandum, *Action: Identifying Acceptable Highway Safety Features* [29], work-zone traffic control devices fall into Category 2. Devices in this hardware category are not expected to produce a significant change in vehicular velocity. However, these devices may still pose safety risks to motorists since they have the potential to penetrate a windshield, injure a worker, or cause vehicle instability when driven over or lodged under a vehicle.

According to TL-3 of MASH, work-zone traffic control devices must be subjected to three full-scale vehicle crash tests. The three full-scale crash tests are as follows:

1. Test designation no. 3-70 consisting of a 2,425-lb (1,100-kg) small car, designated 1100C, impacting at a nominal speed of 19 mph (31 km/h);
2. Test designation no. 3-71 consisting of a 2,425-lb (1,100-kg) small car, designated 1100C, impacting at a speed of 62 mph (100 km/h);
3. Test designation no. 3-72 consisting of a 5,000-lb (2,268-kg) pickup truck, designated 2270P, impacting at a speed of 62 mph (100 km/h).

The low-speed test is intended to evaluate the breakaway, fracture, or yielding mechanism of the device. The high-speed test is intended to evaluate vehicular stability, test article trajectory, and occupant risk factors. Since most work-zone traffic control devices have a relatively small mass (less than 220 lb or 100 kg), the high-speed crash test is more critical due to the propensity of the test article to penetrate into the occupant compartment. Therefore, test designation no. 3-70 was deemed unnecessary for this project. Testing should be conducted at the critical impact angle (CIA), which is the worst case impact condition in which the traffic

control device will be deployed along the roadway. For safety devices that can be used near an intersection and can be impacted from virtually any direction, testing is recommended at both 90 degrees from normal and at any orientation between 0 and 25 degrees. The test conditions of TL-3 work-zone traffic control devices are summarized in Table 10.

Table 10. MASH TL-3 Crash Test Conditions

Test Article	Test Designation No.	Test Vehicle	Impact Conditions			Evaluation Criteria ¹
			Speed		Angle (deg)	
			mph	km/h		
Work Zone Traffic Control Devices	3-70	1100C	19	31	CIA	B,D,E,F,H,I,N
	3-71	1100C	62	100	CIA	B,D,E,F,H,I,N
	3-72	2270P	62	100	CIA	B,D,E,F,H,I,N

¹ Evaluation criteria explained in Table 11.

6.2 Evaluation Criteria

Evaluation criteria for full-scale vehicle crash testing are based on three appraisal areas: (1) structural adequacy; (2) occupant risk; and (3) vehicle trajectory after collision. Criteria for structural adequacy are intended to evaluate the ability of the work-zone traffic control device to break away, fracture, or yield in a predictable manner. Occupant risk evaluates the degree of hazard to occupants in the impacting vehicle—including windshield damage. Vehicle trajectory after collision is a measure of the potential for the post-impact trajectory of the vehicle to cause subsequent multi-vehicle accidents. In such a scenario, the trajectory of the vehicle after collision may subject occupants of other vehicles to undue hazards or subject the occupants of the impacting vehicle to secondary collisions with other fixed objects. These three evaluation criteria are defined in Table 11. The full-scale vehicle crash tests were conducted and reported in accordance with the procedures provided in MASH for Category 2 devices.

In addition to the standard occupant risk measures, the Post-Impact Head Deceleration (PHD), the Theoretical Head Impact Velocity (THIV), and the Acceleration Severity Index (ASI) were determined and reported on the test summary sheet. Additional discussion on PHD, THIV and ASI is provided in MASH.

Table 11. MASH Evaluation Criteria for Traffic Control Devices

Evaluation Factors	Evaluation Criteria					
Structural Adequacy	B. The test article should readily activate in a predictable manner by breaking away, fracturing, or yielding.					
Occupant Risk	D. Detached elements, fragments or other debris from the test article should not penetrate or show potential for penetrating the occupant compartment, or present undue hazard to other traffic, pedestrians, or personnel in a work zone. Deformations of, or intrusions into, the occupant compartment should not exceed limits set forth in Section 5.3 and Appendix E.					
	E. Detached elements, fragments or other debris from the test article, or vehicular damage should not block the driver's vision or otherwise cause the driver to lose control of the vehicle.					
	F. The vehicle should remain upright during and after collision. The maximum roll and pitch angles are not to exceed 75 degrees.					
	H. Occupant Impact Velocities (OIV) (see Appendix A, Section A5.3 for calculation procedure) should satisfy the following limits:					
	Occupant Impact Velocity Limits					
	<table border="1" style="width: 100%; border-collapse: collapse;"> <thead> <tr> <th data-bbox="548 1434 846 1472">Component</th> <th data-bbox="846 1434 1062 1472">Preferred</th> <th data-bbox="1062 1434 1339 1472">Maximum</th> </tr> </thead> <tbody> <tr> <td data-bbox="548 1472 846 1547">Longitudinal</td> <td data-bbox="846 1472 1062 1547" style="text-align: center;">10 ft/s (3.0 m/s)</td> <td data-bbox="1062 1472 1339 1547" style="text-align: center;">16 ft/s (4.9 m/s)</td> </tr> </tbody> </table>	Component	Preferred	Maximum	Longitudinal	10 ft/s (3.0 m/s)
Component	Preferred	Maximum				
Longitudinal	10 ft/s (3.0 m/s)	16 ft/s (4.9 m/s)				
I. The Occupant Ridedown Acceleration (see Appendix A, Section A5.3 for calculation procedure) should satisfy the following limits:						
Occupant Ridedown Acceleration Limits						
<table border="1" style="width: 100%; border-collapse: collapse;"> <thead> <tr> <th data-bbox="548 1694 846 1732">Component</th> <th data-bbox="846 1694 1062 1732">Preferred</th> <th data-bbox="1062 1694 1339 1732">Maximum</th> </tr> </thead> <tbody> <tr> <td data-bbox="548 1732 846 1812">Longitudinal and Lateral</td> <td data-bbox="846 1732 1062 1812" style="text-align: center;">15.0 g's</td> <td data-bbox="1062 1732 1339 1812" style="text-align: center;">20.49 g's</td> </tr> </tbody> </table>	Component	Preferred	Maximum	Longitudinal and Lateral	15.0 g's	20.49 g's
Component	Preferred	Maximum				
Longitudinal and Lateral	15.0 g's	20.49 g's				
Vehicle Trajectory	N. Vehicle trajectory behind the test article is acceptable.					

Windshield damage is a major area of concern when evaluating the safety performance of a work-zone traffic control device [30]. The windshield should not be shattered nor damaged in such a way that visibility is significantly obstructed. Minor chipping and cracking of the windshield is acceptable. Indentation of the windshield by greater than 3 in. (76 mm), a tear in the plastic liner, and penetration of the test article through the windshield are not permitted. Also, roof deformation greater than 4 in. (102 mm) and any other occupant compartment penetration are not permitted. The six main failure criteria are defined in Table 12.

Table 12. MASH Failure Criteria

METHOD OF FAILURE	
1	Severe windshield cracking and fracture
2	Windshield indentation greater than 3 in. (76 mm)
3	Obstruction of driver visibility
4	Windshield penetration
5	Occupant compartment penetration other than windshield penetration
6	Roof deformation greater than 4 in. (102 mm)

7 TEST CONDITIONS

7.1 Test Facility

The testing facility is located at the Lincoln Air Park on the northwest side of the Lincoln Municipal Airport and is approximately 5 miles (8.0 km) northwest of the University of Nebraska-Lincoln.

7.2 Vehicle Tow and Guidance System

A reverse cable tow system with a 1:2 mechanical advantage was used to propel the test vehicle. The distance traveled and the speed of the tow vehicle were one-half that of the test vehicle. The test vehicle was released from the tow cable before impact with the barrier system. A digital speedometer on the tow vehicle increased the accuracy of the test vehicle impact speed.

A vehicle guidance system developed by Hinch [31] was used to steer the test vehicle. A guide-flag, attached to the front-left wheel and the guide cable, was sheared off before impact with the work-zone traffic control devices. The $\frac{3}{8}$ -in. (9.5-mm) diameter guide cable was tensioned to approximately 3,500 lb (15.6 kN) and supported both laterally and vertically every 100 ft (30.5 m) by hinged stanchions. The hinged stanchions stood upright while holding up the guide cable, but as the vehicle was towed down the line, the guide-flag struck and knocked each stanchion to the ground.

7.3 Test Vehicles

For test no. WZ09-1, a 2002 Dodge Ram 1500 Quad Cab pickup truck was used as the test vehicle. The curb, test inertial, and gross static vehicle weights were 5,119 lb (2,322 kg), 4,990 lb (2,263 kg), and 5,159 lb (2,340 kg), respectively. The test vehicle is shown in Figure 29, and vehicle dimensions are shown in Figure 30.



Figure 29. Test Vehicle, Test No. WZ09-1

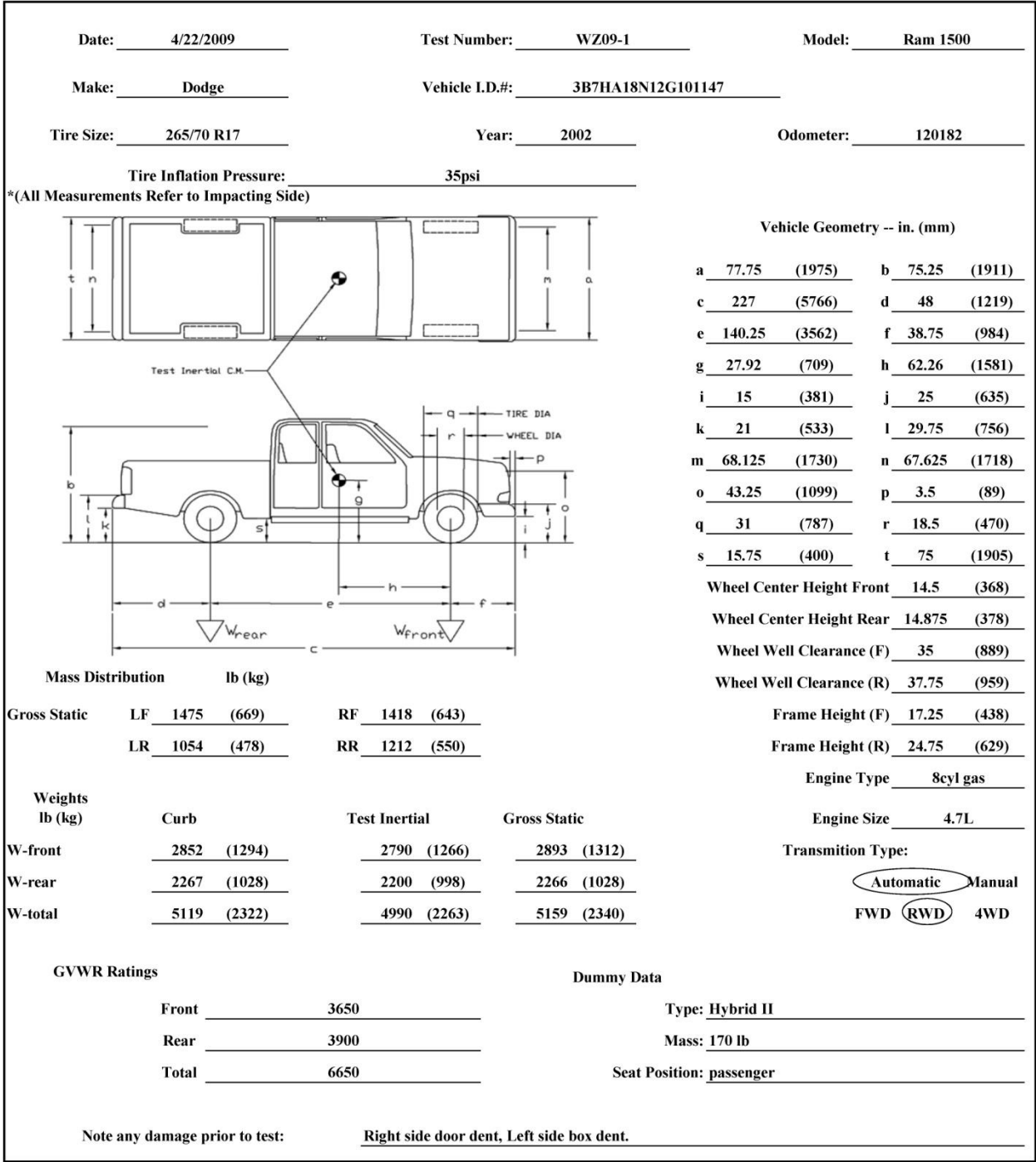

Figure 30. Vehicle Dimensions, Test No. WZ09-1

For test no. WZ09-2, a 2002 Kia Rio passenger car was used as the test vehicle. The curb, test inertial, and gross static vehicle weights were 2,309 lb (1,047 kg), 2,404 lb (1,090 kg), and 2,573 lb (1,167 kg), respectively. The test vehicle is shown in Figure 31, and vehicle dimensions are shown in Figure 32.

For test no. WZ09-3, a 2002 Kia Rio passenger car was used as the test vehicle. The curb, test inertial, and gross static vehicle weights were 2,309 lb (1,047 kg), 2,407 lb (1,092 kg), and 2,575 lb (1,168 kg), respectively. The test vehicle is shown in Figure 33, and vehicle dimensions are shown in Figure 34.

For test no. WZ09-4, a 2002 Dodge Ram 1500 Quad Cab pickup truck was used as the test vehicle. The curb, test inertial, and gross static vehicle weights were 5,119 lb (2,322 kg), 4,988 lb (2,263 kg), and 5,157 lb (2,339 kg), respectively. The test vehicle is shown in Figure 35, and vehicle dimensions are shown in Figure 36.

The longitudinal component of the centers of gravity (c.g.) was determined using the measured axle weights. The Suspension Method ([32](#)) was used to determine the vertical component of the c.g. for the pickup truck test vehicles. This method is based on the principle that the c.g. of any freely suspended body is in the vertical plane through the point of suspension. The vehicle was suspended successively in three positions, and the respective planes containing the c.g. were established. The intersection of these planes pinpointed the c.g. location. The location of the final c.g. is shown in Figures 30 and 37 for test no. WZ09-1. The location of the final c.g. is shown in Figures 32 and 38 for test no. WZ09-2. The location of the final c.g. is shown in Figures 34 and 39 for test no. WZ09-3. The location of the final c.g. is shown in Figures 36 and 40 for test no. WZ09-4. Data used for the c.g. calculations and ballast information is shown in Appendix D.



Figure 31. Test Vehicle, Test No. WZ09-2

Date: 4/22/2009 Test Number: WZ09-2 Model: RIO
Make: KIA Vehicle I.D.#: KNADC123326141647
Tire Size: P175 / 65R14 Year: 2002 Odometer: 59138
Tire Inflation Pressure: 29

*(All Measurements Refer to Impacting Side)

Vehicle Geometry -- in. (mm)

a	<u>63.5 (1613)</u>	b	<u>56.25 (1429)</u>
c	<u>165.75 (4210)</u>	d	<u>37 (940)</u>
e	<u>94.75 (2407)</u>	f	<u>34 (864)</u>
g	<u>18 (457)</u>	h	<u>38.94 (989)</u>
i	<u>8.25 (210)</u>	j	<u>20 (508)</u>
k	<u>11.25 (286)</u>	l	<u>21.75 (552)</u>
m	<u>56 (1422)</u>	n	<u>56.75 (1441)</u>
o	<u>26 (660)</u>	p	<u>3 (76)</u>
q	<u>15.5 (394)</u>	r	<u>22.5 (572)</u>
s	<u>11.75 (298)</u>	t	<u>65.5 (1664)</u>
Wheel Center Height Front		<u>10.5 (267)</u>	
Wheel Center Height Rear		<u>10.875 (276)</u>	
Wheel Well Clearance (F)		<u>24.5 (622)</u>	
Wheel Well Clearance (R)		<u>24.25 (616)</u>	
Frame Height (F)		<u>15.75 (400)</u>	
Frame Height (R)		<u>7.75 (197)</u>	
Engine Type		<u>4 cyl Gas</u>	
Engine Size		<u>1.5L</u>	
Transmission Type:			
		<u>Automatic</u> <u>Manual</u>	
		<u>FWD</u> <u>RWD</u> <u>4WD</u>	

Mass Distribution		lb (kg)	
Gross Static	LF	<u>724 (328)</u>	RF <u>767 (348)</u>
	LR	<u>507 (230)</u>	RR <u>575 (261)</u>
Weights		lb (kg)	
	Curb	Test Inertial	
		Gross Static	
W-front	<u>1429 (648)</u>	<u>1409 (639)</u>	<u>1491 (676)</u>
W-rear	<u>880 (399)</u>	<u>995 (451)</u>	<u>1082 (491)</u>
W-total	<u>2309 (1047)</u>	<u>2404 (1090)</u>	<u>2573 (1167)</u>

GVWR Ratings		Dummy Data	
Front	<u>1634</u>	Type:	<u>Hybrid I</u>
Rear	<u>1561</u>	Mass:	<u>170 lb</u>
Total	<u>3195</u>	Seat Position:	<u>Passenger</u>

Note any damage prior to test: Driver door dents and small dent right front fender.

Figure 32. Vehicle Dimensions, Test No. WZ09-2



Figure 33. Test Vehicle, Test No. WZ09-3

Date: <u>9/14/2009</u>		Test Number: <u>WZ09-3</u>		Model: <u>Rio (1100C)</u>																																																																																																																									
Make: <u>Kia</u>		Vehicle I.D.#: <u>KNADC123326141647</u>																																																																																																																											
Tire Size: <u>P175/65 R14</u>		Year: <u>2002</u>		Odometer: <u>59138</u>																																																																																																																									
Tire Inflation Pressure: <u>29 Psi</u>																																																																																																																													
*(All Measurements Refer to Impacting Side)																																																																																																																													
			Vehicle Geometry -- in. (mm)																																																																																																																										
			<table border="0" style="width: 100%;"> <tr> <td>a</td><td><u>63.5</u></td><td>(1613)</td> <td>b</td><td><u>55.25</u></td><td>(1403)</td> </tr> <tr> <td>c</td><td><u>165.75</u></td><td>(4210)</td> <td>d</td><td><u>37</u></td><td>(940)</td> </tr> <tr> <td>e</td><td><u>94.75</u></td><td>(2407)</td> <td>f</td><td><u>34</u></td><td>(864)</td> </tr> <tr> <td>g</td><td><u>18</u></td><td>(457)</td> <td>h</td><td><u>38.94</u></td><td>(989)</td> </tr> <tr> <td>i</td><td><u>8</u></td><td>(203)</td> <td>j</td><td><u>21</u></td><td>(533)</td> </tr> <tr> <td>k</td><td><u>10</u></td><td>(254)</td> <td>l</td><td><u>22.5</u></td><td>(572)</td> </tr> <tr> <td>m</td><td><u>56</u></td><td>(1422)</td> <td>n</td><td><u>56.75</u></td><td>(1441)</td> </tr> <tr> <td>o</td><td><u>25</u></td><td>(635)</td> <td>p</td><td><u>2.5</u></td><td>(64)</td> </tr> <tr> <td>q</td><td><u>22.5</u></td><td>(572)</td> <td>r</td><td><u>15.25</u></td><td>(387)</td> </tr> <tr> <td>s</td><td><u>12</u></td><td>(305)</td> <td>t</td><td><u>65.5</u></td><td>(1664)</td> </tr> <tr> <td colspan="3">Wheel Center Height Front</td><td colspan="3"><u>10.5</u> (267)</td> </tr> <tr> <td colspan="3">Wheel Center Height Rear</td><td colspan="3"><u>11</u> (279)</td> </tr> <tr> <td colspan="3">Wheel Well Clearance (F)</td><td colspan="3"><u>24.25</u> (616)</td> </tr> <tr> <td colspan="3">Wheel Well Clearance (R)</td><td colspan="3"><u>24.25</u> (616)</td> </tr> <tr> <td colspan="3">Frame Height (F)</td><td colspan="3"><u>7</u> (178)</td> </tr> <tr> <td colspan="3">Frame Height (R)</td><td colspan="3"><u>16</u> (406)</td> </tr> <tr> <td colspan="3">Engine Type</td><td colspan="3"><u>4 cyl. Gas</u></td> </tr> <tr> <td colspan="3">Engine Size</td><td colspan="3"><u>1.5L</u></td> </tr> <tr> <td colspan="3">Transmission Type:</td><td colspan="3"> <input checked="" type="radio"/> Automatic <input type="radio"/> Manual </td> </tr> <tr> <td colspan="3"></td><td colspan="3"> <input checked="" type="radio"/> FWD <input type="radio"/> RWD <input type="radio"/> 4WD </td> </tr> </table>			a	<u>63.5</u>	(1613)	b	<u>55.25</u>	(1403)	c	<u>165.75</u>	(4210)	d	<u>37</u>	(940)	e	<u>94.75</u>	(2407)	f	<u>34</u>	(864)	g	<u>18</u>	(457)	h	<u>38.94</u>	(989)	i	<u>8</u>	(203)	j	<u>21</u>	(533)	k	<u>10</u>	(254)	l	<u>22.5</u>	(572)	m	<u>56</u>	(1422)	n	<u>56.75</u>	(1441)	o	<u>25</u>	(635)	p	<u>2.5</u>	(64)	q	<u>22.5</u>	(572)	r	<u>15.25</u>	(387)	s	<u>12</u>	(305)	t	<u>65.5</u>	(1664)	Wheel Center Height Front			<u>10.5</u> (267)			Wheel Center Height Rear			<u>11</u> (279)			Wheel Well Clearance (F)			<u>24.25</u> (616)			Wheel Well Clearance (R)			<u>24.25</u> (616)			Frame Height (F)			<u>7</u> (178)			Frame Height (R)			<u>16</u> (406)			Engine Type			<u>4 cyl. Gas</u>			Engine Size			<u>1.5L</u>			Transmission Type:			<input checked="" type="radio"/> Automatic <input type="radio"/> Manual						<input checked="" type="radio"/> FWD <input type="radio"/> RWD <input type="radio"/> 4WD		
a	<u>63.5</u>	(1613)	b	<u>55.25</u>	(1403)																																																																																																																								
c	<u>165.75</u>	(4210)	d	<u>37</u>	(940)																																																																																																																								
e	<u>94.75</u>	(2407)	f	<u>34</u>	(864)																																																																																																																								
g	<u>18</u>	(457)	h	<u>38.94</u>	(989)																																																																																																																								
i	<u>8</u>	(203)	j	<u>21</u>	(533)																																																																																																																								
k	<u>10</u>	(254)	l	<u>22.5</u>	(572)																																																																																																																								
m	<u>56</u>	(1422)	n	<u>56.75</u>	(1441)																																																																																																																								
o	<u>25</u>	(635)	p	<u>2.5</u>	(64)																																																																																																																								
q	<u>22.5</u>	(572)	r	<u>15.25</u>	(387)																																																																																																																								
s	<u>12</u>	(305)	t	<u>65.5</u>	(1664)																																																																																																																								
Wheel Center Height Front			<u>10.5</u> (267)																																																																																																																										
Wheel Center Height Rear			<u>11</u> (279)																																																																																																																										
Wheel Well Clearance (F)			<u>24.25</u> (616)																																																																																																																										
Wheel Well Clearance (R)			<u>24.25</u> (616)																																																																																																																										
Frame Height (F)			<u>7</u> (178)																																																																																																																										
Frame Height (R)			<u>16</u> (406)																																																																																																																										
Engine Type			<u>4 cyl. Gas</u>																																																																																																																										
Engine Size			<u>1.5L</u>																																																																																																																										
Transmission Type:			<input checked="" type="radio"/> Automatic <input type="radio"/> Manual																																																																																																																										
			<input checked="" type="radio"/> FWD <input type="radio"/> RWD <input type="radio"/> 4WD																																																																																																																										
<table border="0" style="width: 100%;"> <tr> <td colspan="2">Mass Distribution</td> <td colspan="2">lb (kg)</td> <td colspan="2"></td> </tr> <tr> <td>Gross Static</td> <td>LF</td> <td><u>716</u></td> <td>(325)</td> <td>RF</td> <td><u>787</u></td> <td>(357)</td> </tr> <tr> <td></td> <td>LR</td> <td><u>520</u></td> <td>(236)</td> <td>RR</td> <td><u>552</u></td> <td>(250)</td> </tr> <tr> <td colspan="2">Weights</td> <td colspan="2">lb (kg)</td> <td colspan="2">Test Inertial</td> <td colspan="2">Gross Static</td> </tr> <tr> <td>W-front</td> <td></td> <td><u>1429</u></td> <td>(648)</td> <td><u>1413</u></td> <td>(641)</td> <td><u>1503</u></td> <td>(682)</td> </tr> <tr> <td>W-rear</td> <td></td> <td><u>880</u></td> <td>(399)</td> <td><u>994</u></td> <td>(451)</td> <td><u>1072</u></td> <td>(486)</td> </tr> <tr> <td>W-total</td> <td></td> <td><u>2309</u></td> <td>(1047)</td> <td><u>2407</u></td> <td>(1092)</td> <td><u>2575</u></td> <td>(1168)</td> </tr> </table>						Mass Distribution		lb (kg)				Gross Static	LF	<u>716</u>	(325)	RF	<u>787</u>	(357)		LR	<u>520</u>	(236)	RR	<u>552</u>	(250)	Weights		lb (kg)		Test Inertial		Gross Static		W-front		<u>1429</u>	(648)	<u>1413</u>	(641)	<u>1503</u>	(682)	W-rear		<u>880</u>	(399)	<u>994</u>	(451)	<u>1072</u>	(486)	W-total		<u>2309</u>	(1047)	<u>2407</u>	(1092)	<u>2575</u>	(1168)																																																																				
Mass Distribution		lb (kg)																																																																																																																											
Gross Static	LF	<u>716</u>	(325)	RF	<u>787</u>	(357)																																																																																																																							
	LR	<u>520</u>	(236)	RR	<u>552</u>	(250)																																																																																																																							
Weights		lb (kg)		Test Inertial		Gross Static																																																																																																																							
W-front		<u>1429</u>	(648)	<u>1413</u>	(641)	<u>1503</u>	(682)																																																																																																																						
W-rear		<u>880</u>	(399)	<u>994</u>	(451)	<u>1072</u>	(486)																																																																																																																						
W-total		<u>2309</u>	(1047)	<u>2407</u>	(1092)	<u>2575</u>	(1168)																																																																																																																						
GVWR Ratings Front <u>1634</u> Rear <u>1561</u> Total <u>3195</u>			Dummy Data Type: <u>Hybrid 1</u> Mass: <u>170 lb</u> Seat Position: <u>Passenger</u>																																																																																																																										
Note any damage prior to test: <u>Vehicle was repaired from WZ09-2 damage.</u>																																																																																																																													

Figure 34. Vehicle Dimensions, Test No. WZ09-3



Figure 35. Test Vehicle, Test No. WZ09-4

Date: <u>9/16/2009</u>	Test Number: <u>WZ09-4</u>	Model: <u>Ram 1500 (2270P)</u>																																								
Make: <u>Dodge</u>	Vehicle I.D.#: <u>3B7HA18N12G101147</u>																																									
Tire Size: <u>265/70 R17</u>	Year: <u>2002</u>	Odometer: <u>120182</u>																																								
Tire Inflation Pressure: <u>35psi</u>																																										
*(All Measurements Refer to Impacting Side)																																										
		<p style="text-align: center;">Vehicle Geometry -- in. (mm)</p> <table style="width: 100%; border-collapse: collapse;"> <tr><td>a</td><td><u>77.75 (1975)</u></td><td>b</td><td><u>75.25 (1911)</u></td></tr> <tr><td>c</td><td><u>227 (5766)</u></td><td>d</td><td><u>48 (1219)</u></td></tr> <tr><td>e</td><td><u>140.25 (3562)</u></td><td>f</td><td><u>38.75 (984)</u></td></tr> <tr><td>g</td><td><u>28.09 (714)</u></td><td>h</td><td><u>62.26 (1581)</u></td></tr> <tr><td>i</td><td><u>15.5 (394)</u></td><td>j</td><td><u>28 (711)</u></td></tr> <tr><td>k</td><td><u>21 (533)</u></td><td>l</td><td><u>29 (737)</u></td></tr> <tr><td>m</td><td><u>68.125 (1730)</u></td><td>n</td><td><u>67.625 (1718)</u></td></tr> <tr><td>o</td><td><u>44 (1118)</u></td><td>p</td><td><u>3.5 (89)</u></td></tr> <tr><td>q</td><td><u>31 (787)</u></td><td>r</td><td><u>18.5 (470)</u></td></tr> <tr><td>s</td><td><u>16 (406)</u></td><td>t</td><td><u>75 (1905)</u></td></tr> </table> <p>Wheel Center Height Front <u>14.5 (368)</u> Wheel Center Height Rear <u>14.875 (378)</u> Wheel Well Clearance (F) <u>36 (914)</u> Wheel Well Clearance (R) <u>38 (965)</u> Frame Height (F) <u>18.25 (464)</u> Frame Height (R) <u>25.5 (648)</u> Engine Type <u>8cyl. Gas</u> Engine Size <u>4.7L</u> Transmission Type: <input checked="" type="radio"/> Automatic <input type="radio"/> Manual FWD <input checked="" type="radio"/> RWD <input type="radio"/> 4WD</p>	a	<u>77.75 (1975)</u>	b	<u>75.25 (1911)</u>	c	<u>227 (5766)</u>	d	<u>48 (1219)</u>	e	<u>140.25 (3562)</u>	f	<u>38.75 (984)</u>	g	<u>28.09 (714)</u>	h	<u>62.26 (1581)</u>	i	<u>15.5 (394)</u>	j	<u>28 (711)</u>	k	<u>21 (533)</u>	l	<u>29 (737)</u>	m	<u>68.125 (1730)</u>	n	<u>67.625 (1718)</u>	o	<u>44 (1118)</u>	p	<u>3.5 (89)</u>	q	<u>31 (787)</u>	r	<u>18.5 (470)</u>	s	<u>16 (406)</u>	t	<u>75 (1905)</u>
a	<u>77.75 (1975)</u>	b	<u>75.25 (1911)</u>																																							
c	<u>227 (5766)</u>	d	<u>48 (1219)</u>																																							
e	<u>140.25 (3562)</u>	f	<u>38.75 (984)</u>																																							
g	<u>28.09 (714)</u>	h	<u>62.26 (1581)</u>																																							
i	<u>15.5 (394)</u>	j	<u>28 (711)</u>																																							
k	<u>21 (533)</u>	l	<u>29 (737)</u>																																							
m	<u>68.125 (1730)</u>	n	<u>67.625 (1718)</u>																																							
o	<u>44 (1118)</u>	p	<u>3.5 (89)</u>																																							
q	<u>31 (787)</u>	r	<u>18.5 (470)</u>																																							
s	<u>16 (406)</u>	t	<u>75 (1905)</u>																																							
<p>Mass Distribution</p> <table style="width: 100%; border-collapse: collapse;"> <thead> <tr> <th></th> <th colspan="2">lb (kg)</th> </tr> </thead> <tbody> <tr> <td>Gross Static</td> <td>LF <u>1432 (650)</u></td> <td>RF <u>1457 (661)</u></td> </tr> <tr> <td></td> <td>LR <u>1110 (503)</u></td> <td>RR <u>1158 (525)</u></td> </tr> </tbody> </table>			lb (kg)		Gross Static	LF <u>1432 (650)</u>	RF <u>1457 (661)</u>		LR <u>1110 (503)</u>	RR <u>1158 (525)</u>																																
	lb (kg)																																									
Gross Static	LF <u>1432 (650)</u>	RF <u>1457 (661)</u>																																								
	LR <u>1110 (503)</u>	RR <u>1158 (525)</u>																																								
<p>Weights</p> <table style="width: 100%; border-collapse: collapse;"> <thead> <tr> <th></th> <th>Curb</th> <th>Test Inertial</th> <th>Gross Static</th> </tr> </thead> <tbody> <tr> <td>W-front</td> <td><u>2852 (1294)</u></td> <td><u>2784 (1263)</u></td> <td><u>2889 (1310)</u></td> </tr> <tr> <td>W-rear</td> <td><u>2267 (1028)</u></td> <td><u>2204 (1000)</u></td> <td><u>2268 (1029)</u></td> </tr> <tr> <td>W-total</td> <td><u>5119 (2322)</u></td> <td><u>4988 (2263)</u></td> <td><u>5157 (2339)</u></td> </tr> </tbody> </table>			Curb	Test Inertial	Gross Static	W-front	<u>2852 (1294)</u>	<u>2784 (1263)</u>	<u>2889 (1310)</u>	W-rear	<u>2267 (1028)</u>	<u>2204 (1000)</u>	<u>2268 (1029)</u>	W-total	<u>5119 (2322)</u>	<u>4988 (2263)</u>	<u>5157 (2339)</u>																									
	Curb	Test Inertial	Gross Static																																							
W-front	<u>2852 (1294)</u>	<u>2784 (1263)</u>	<u>2889 (1310)</u>																																							
W-rear	<u>2267 (1028)</u>	<u>2204 (1000)</u>	<u>2268 (1029)</u>																																							
W-total	<u>5119 (2322)</u>	<u>4988 (2263)</u>	<u>5157 (2339)</u>																																							
<p>GVWR Ratings</p> <table style="width: 100%; border-collapse: collapse;"> <tr><td>Front</td><td><u>3650</u></td></tr> <tr><td>Rear</td><td><u>3900</u></td></tr> <tr><td>Total</td><td><u>5119</u></td></tr> </table>		Front	<u>3650</u>	Rear	<u>3900</u>	Total	<u>5119</u>	<p>Dummy Data</p> <p>Type: <u>Hybrid II</u> Mass: <u>170 lb</u> Seat Position: <u>Passenger</u></p>																																		
Front	<u>3650</u>																																									
Rear	<u>3900</u>																																									
Total	<u>5119</u>																																									
<p>Note any damage prior to test: <u>Repaired damage from WZ09-1</u></p>																																										

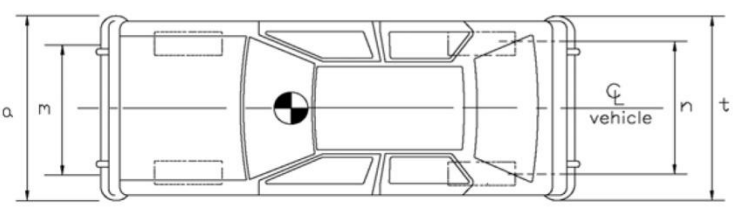
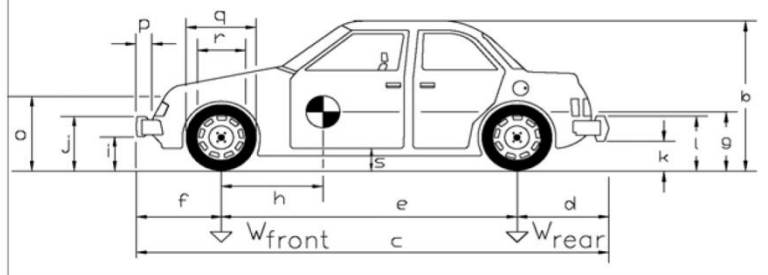
Figure 36. Vehicle Dimensions, Test No. WZ09-4

Square, black- and white-checked targets were placed on the vehicles to aid in the analysis of the high-speed videos, as shown in Figures 37 through 40. Round, checked targets were placed at the center of gravity on the left-side door, the right-side door, and the roof of the vehicle. The remaining targets were located for references so that they could be viewed from the high-speed cameras for video analysis.

The front wheels of the test vehicles were aligned for camber, caster, and toe-in values of zero so that the vehicles would track properly along the guide cable. A 5B flash bulb was mounted on the both sides of the vehicles' dash to pinpoint the time of impact with each of the portable sign supports on the high-speed videos. The flash bulbs were fired by pressure tape switches mounted at the quarter points on the front face of the bumpers. A remote controlled brake system was installed in the test vehicles, so the vehicles could be brought safely to a stop after the tests.

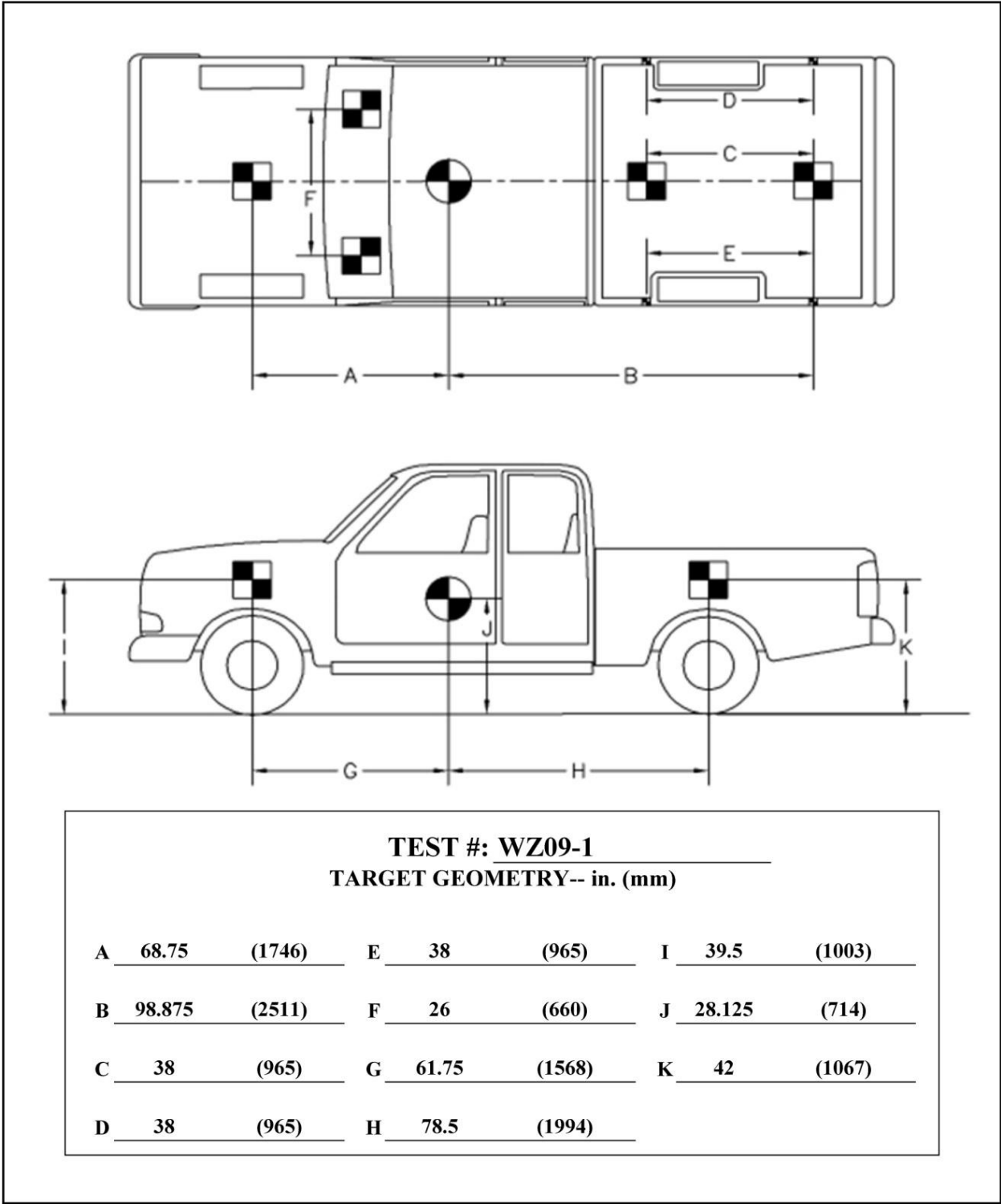

Figure 37. Target Geometry, Test No. WZ09-1

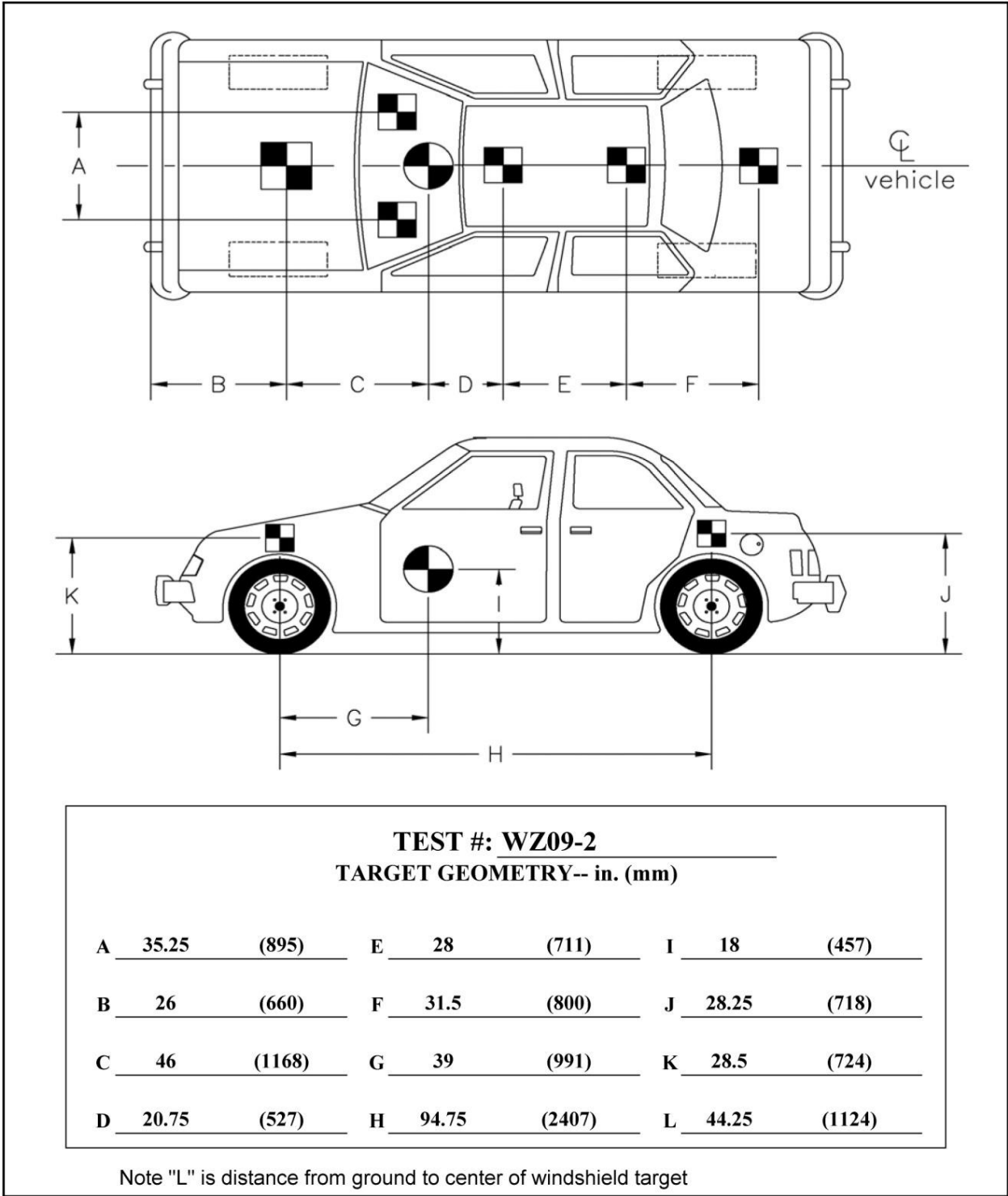

Figure 38. Target Geometry, Test No. WZ09-2

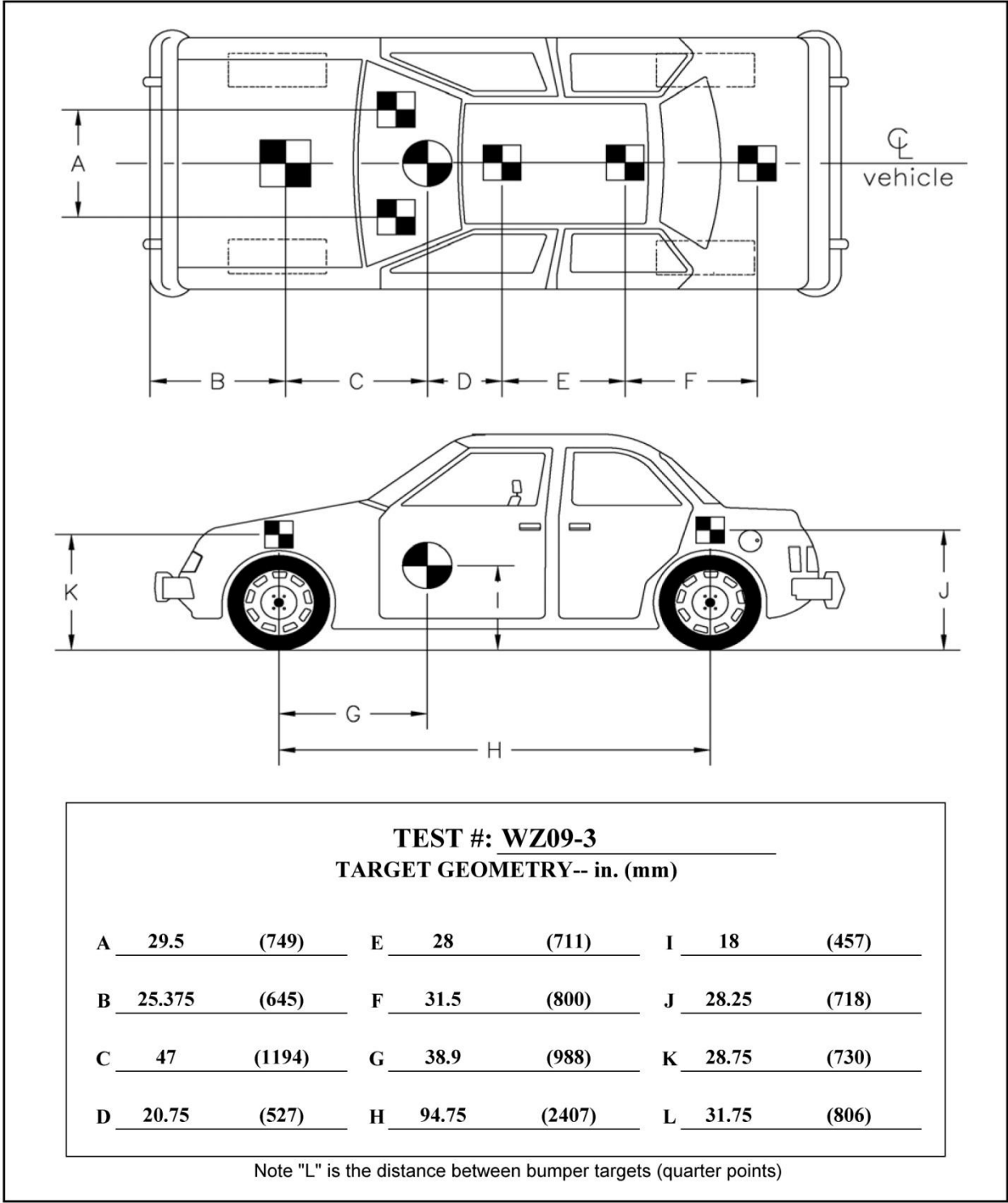

Figure 39. Target Geometry, Test No. WZ09-3

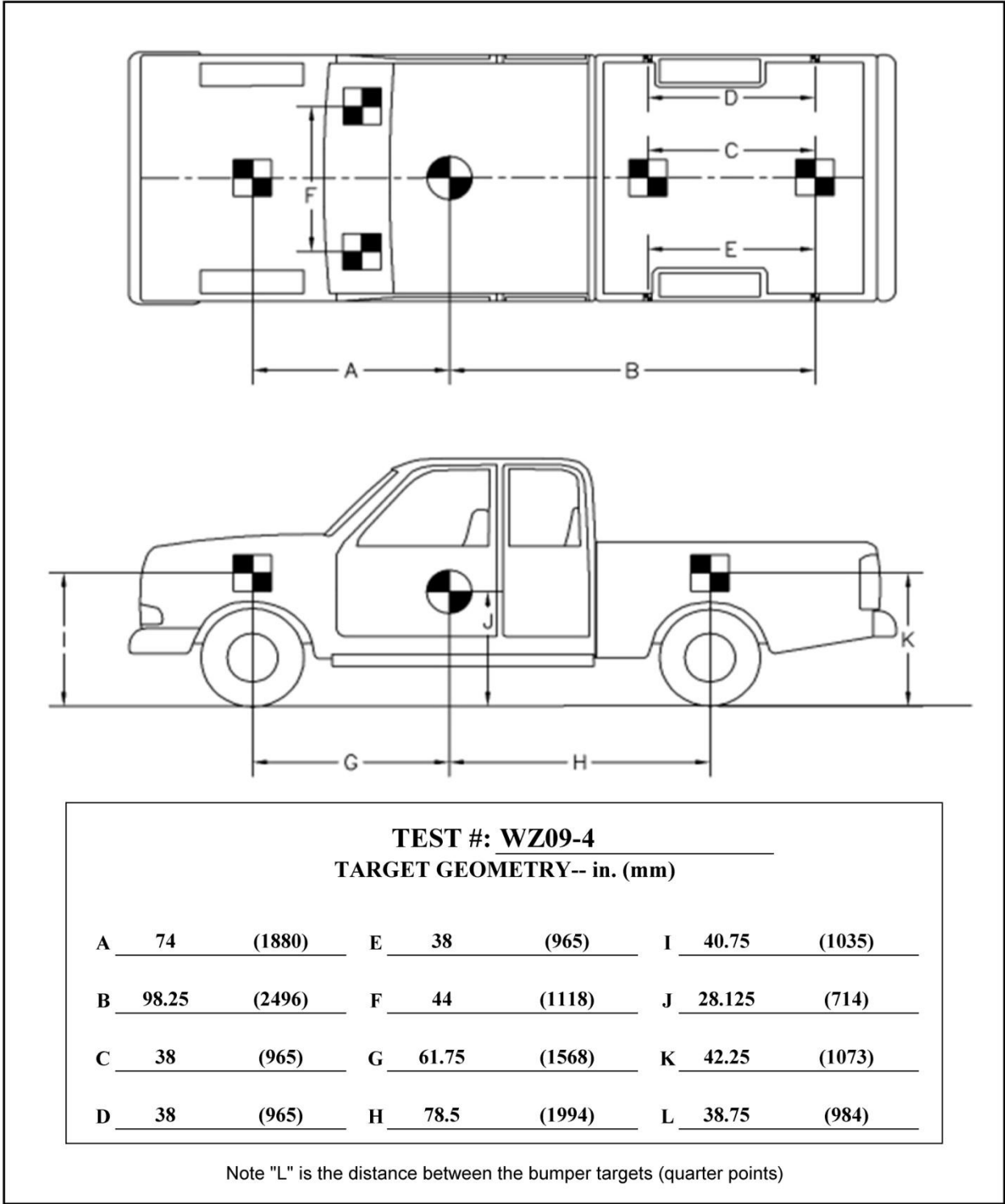

Figure 40. Target Geometry, Test No. WZ09-4

7.4 Simulated Occupant

For test nos. WZ09-1 through WZ09-4, a Hybrid II 50th Percentile Adult Male Dummy was placed in the right-front seat of the test vehicle with the seat belt fastened. The dummy was equipped with clothing and footwear and had a final weight of 170 lb (77 kg). The dummy was manufactured by Android Systems of Carson California under model no. 572 and serial no. 451. As recommended by MASH, the dummy was not included in the calculation of the c.g location.

7.5 Data Acquisition Systems

7.5.1 Accelerometers

Three environmental shock and vibration sensor/recorder systems were used to measure the accelerations in the longitudinal, lateral, and vertical directions. All of the accelerometers were mounted near the center of gravity of the test vehicles. For test no. WZ09-1, the EDR-3 and EDR-4 accelerometers were used. For test nos. WZ09-2, WZ09-3, and WZ09-4, the EDR-3 and DTS accelerometers were used.

One triaxial piezoresistive accelerometer system, Model EDR-4 6DOF-500/1200, was developed and manufactured by Instrumented Sensor Technology (IST) of Okemos, Michigan and includes three differential channels as well as three single-ended channels. The EDR-4 6DOF-500/1200 was configured with 24 MB of RAM memory, a range of ± 500 g's, a sample rate of 10,000 Hz, and a 1,677 Hz anti-aliasing filter. "EDR4COM" and "DynaMax Suite" computer software programs and a customized Microsoft Excel worksheet were used to analyze and plot the accelerometer data.

The second system was a two-Arm piezoresistive accelerometer system developed by Endevco of San Juan Capistrano, California. Three accelerometers were used to measure each of the longitudinal, lateral, and vertical accelerations independently at a sample rate of 10,000 Hz.

The accelerometers were configured and controlled using a system developed and manufactured by Diversified Technical Systems, Inc. (DTS) of Seal Beach, California. More specifically, data was collected using a DTS Sensor Input Module (SIM), Model TDAS3-SIM-16M. The SIM was configured with 16 MB SRAM memory and 8 sensor input channels with 250 kB SRAM/channel. The SIM was mounted on a TDAS3-R4 module rack. The module rack was configured with isolated power/event/communications, 10BaseT Ethernet and RS232 communication, and an internal backup battery. Both the SIM and module rack were crashworthy. The computer software program “DTS TDAS Control” and a customized Microsoft Excel worksheet were used to analyze and plot the accelerometer data.

The third system, Model EDR-3, was a triaxial piezoresistive accelerometer system developed and manufactured by IST of Okemos, Michigan. The EDR-3 was configured with 256 kB of RAM memory, a range of ± 200 g's, a sample rate of 3,200 Hz, and a 1,120 Hz low-pass filter. The computer software program “DynaMax 1 (DM-1)” and a customized Microsoft Excel worksheet were used to analyze and plot the accelerometer data.

7.5.2 Rate Transducers

An Analog Systems 3-axis rate transducer with a range of 1,200 degrees/sec in each of the three directions (roll, pitch, and yaw) was used to measure the rates of motion of the test vehicle in test no. WZ09-1. The rate transducer was mounted inside the body of the EDR-4 6DOF-500/1200. Data was recorded at 10,000 Hz to a second data acquisition board inside the EDR-4 6DOF-500/1200 housing. The raw data measurements were then downloaded, converted to the appropriate Euler angles for analysis, and plotted. “EDR4COM” and “DynaMap Suite” computer software programs and a customized Microsoft Excel worksheet were used to analyze and plot the angular rate sensor data.

A different angular rate transducer, the ARS-1500, with a range of 1,500 degrees/sec in each of the three directions (roll, pitch, and yaw) was used to measure the rates of rotation of the test vehicles in test nos. WZ09-2, WZ09-3, and WZ09-4. The angular rate sensor was mounted on an aluminum block inside the test vehicle near the center of gravity. Data was recorded at 10,000 Hz to the SIM unit. The raw data measurements were then downloaded, converted to the proper Euler angles for analysis, and plotted. The computer software program “DTS TDAS Control” and a customized Microsoft Excel worksheet were used to analyze and plot the angular rate sensor data.

7.5.3 Pressure Tape Switches

For test nos. WZ09-1 through WZ09-4, two sets of three pressure-activated tape switches, spaced at 6.6-ft (2-m) intervals, were used to determine the speed of the vehicle before impact with each device. Each tape switch fired a strobe light which sent an electronic timing signal to the data acquisition system as the right-front tire of the test vehicle passed over it. Test vehicle speeds were determined from electronic timing mark data recorded using TestPoint and LabVIEW computer software programs. Strobe lights and high-speed video analysis are used only as a backup in the event that vehicle speed cannot be determined from the electronic data.

7.5.4 High-Speed Photography

Three high-speed AOS X-PRI digital video cameras, three JVC digital video cameras, and two Canon digital video cameras were utilized to film test no. WZ09-1. A schematic of the camera locations, camera lens information, and camera operating speeds are shown in Figure 41.

One high-speed AOS VITcam digital video camera, three high-speed AOS X-PRI digital video cameras, four JVC digital video cameras, and two Canon digital video cameras were

utilized to film test no. WZ09-2. A schematic of the camera locations, camera lens information, and camera operating speeds are shown in Figure 42.

Two high-speed AOS VITcam digital video cameras, three high-speed AOS X-PRI digital video cameras, and four JVC digital video cameras were utilized to film test no. WZ09-3. A schematic of the camera locations, camera lens information, and camera operating speeds are shown in Figure 43.

Two high-speed AOS VITcam digital video cameras, three high-speed AOS X-PRI digital video cameras, four JVC digital video cameras, and one Canon digital video camera were utilized to film test no. WZ09-4. A schematic of the camera locations, camera lens information, and camera operating speeds are shown in Figure 44. The high-speed videos were analyzed using ImageExpress MotionPlus software. Actual camera speed and camera divergence factors were considered in the analysis of the high-speed videos.

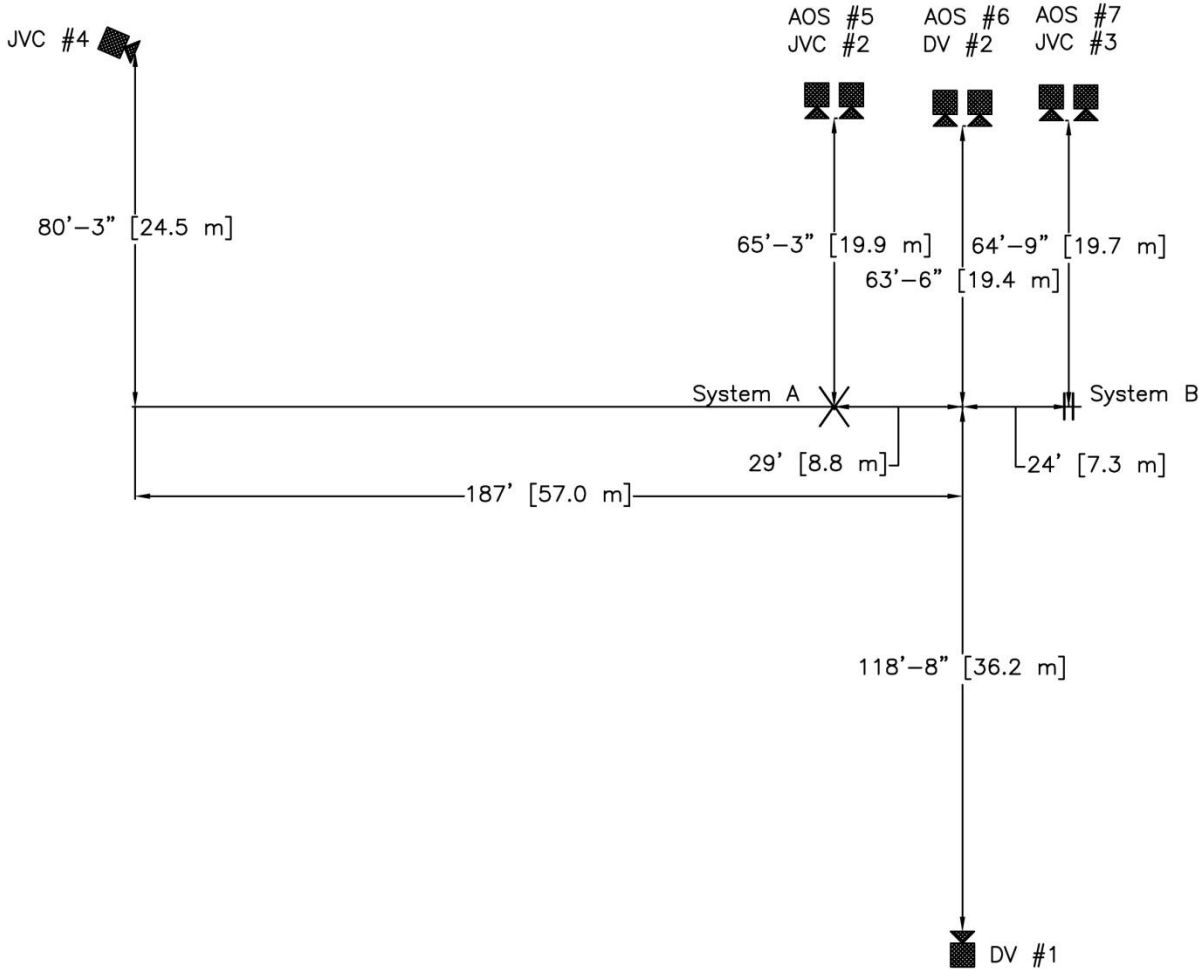

	No.	Type	Operating Speed (frames/sec)	Lens	Lens Setting
High-Speed Video	5	AOS X-PRI	500	Sigma 24-70	50
	6	AOS X-PRI	500	Cosmicar 12.5 fixed	-
	7	AOS X-PRI	500	Sigma 50 fixed	-
Digital Video	2	JVC - GZ-MG27u (Everio)	29.97		
	3	JVC - GZ-MG27u (Everio)	29.97		
	4	JVC - GZ-MG27u (Everio)	29.97		
	1	Canon-ZR90	29.97		
	2	Canon-ZR10	29.97		

Figure 41. Camera Locations, Speeds, and Lens Settings, Test No. WZ09-1

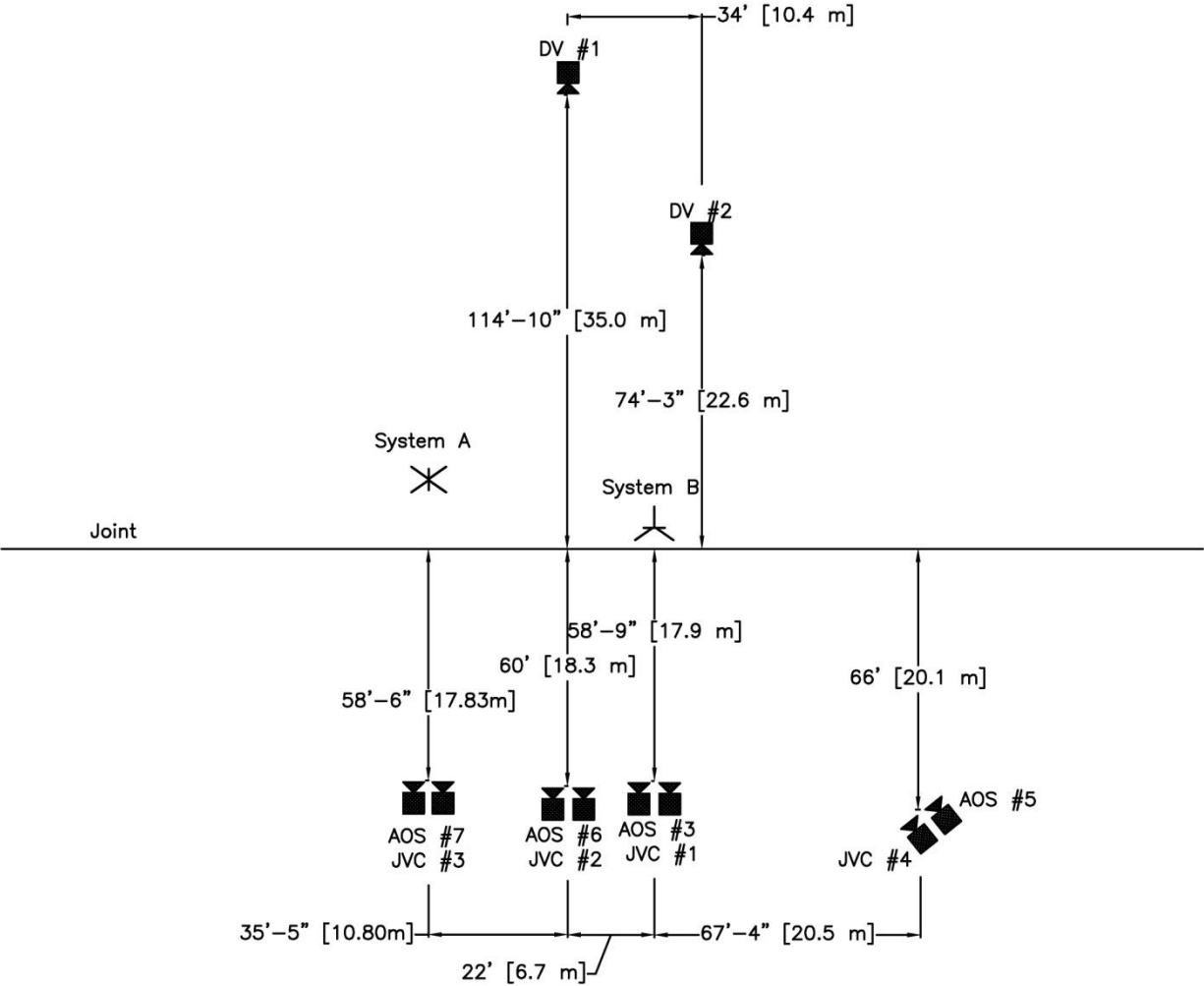

	No.	Type	Operating Speed (frames/sec)	Lens	Lens Setting
High-Speed Video	3	AOS VITcam CTM	500	Fujinon 50 mm fixed	-
	5	AOS X-PRI	500	Sigma 24-70	70
	6	AOS X-PRI	500	Cosmicar 12.5 mm fixed	-
	7	AOS X-PRI	500	Sigma 50 mm fixed	-
Digital Video	1	JVC - GZ-MC500 (Everio)	29.97		
	2	JVC - GZ-MG27u (Everio)	29.97		
	3	JVC - GZ-MG27u (Everio)	29.97		
	4	JVC - GZ-MG27u (Everio)	29.97		
	1	Canon-ZR90	29.97		
	2	Canon-ZR10	29.97		

Figure 42. Camera Locations, Speeds, and Lens Settings, Test No. WZ09-2

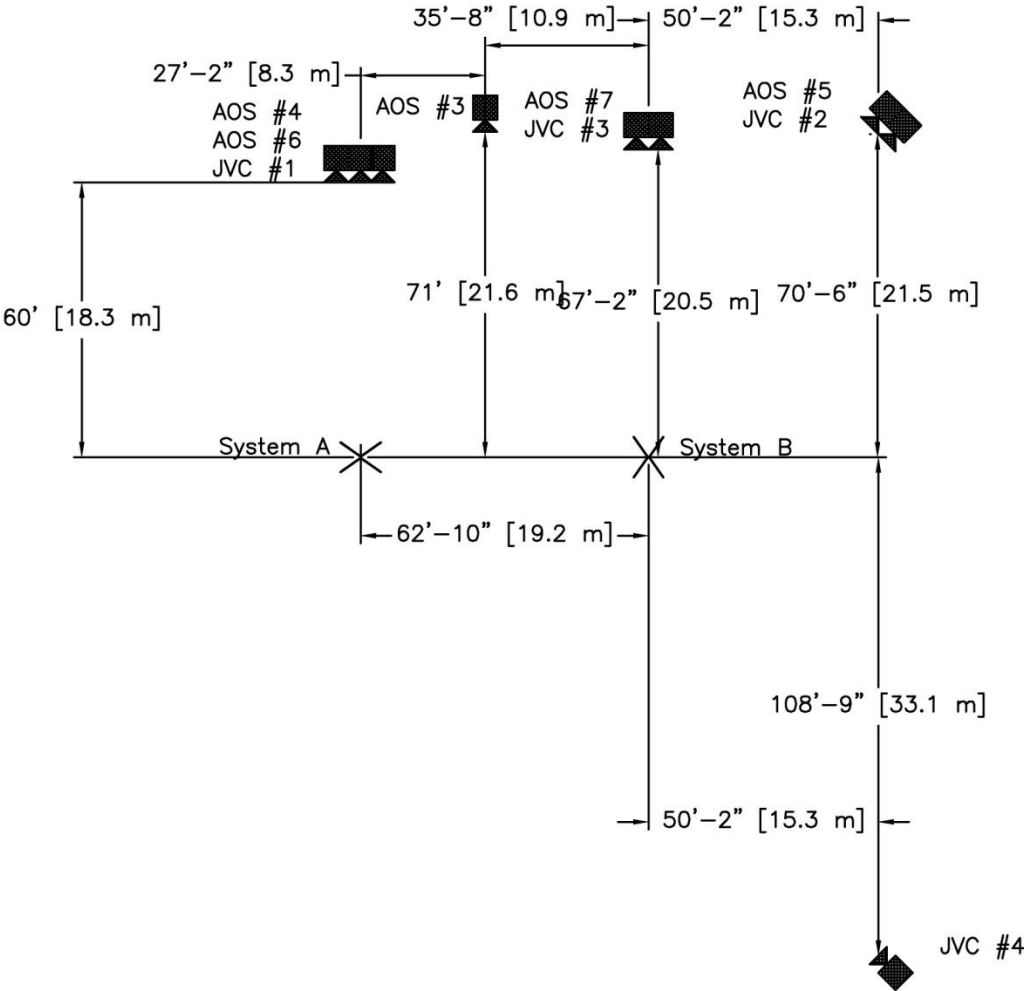

	No.	Type	Operating Speed (frames/sec)	Lens	Lens Setting
High-Speed Video	3	AOS VITcam CTM	500	Cosmicar 12.5 mm fixed	-
	4	AOS VITcam CTM	500	Sigma 24-125 mm	135
	5	AOS X-PRI	500	Tamron 100-300 mm	135
	6	AOS X-PRI	500	Sigma 24-70 mm	50
	7	AOS X-PRI	500	Fujinon 50 mm fixed	-
Digital Video	1	JVC - GZ-MC500 (Everio)	29.97		
	2	JVC - GZ-MG27u (Everio)	29.97		
	3	JVC - GZ-MG27u (Everio)	29.97		
	4	JVC - GZ-MG27u (Everio)	29.97		

Figure 43. Camera Locations, Speeds, and Lens Settings, Test No. WZ09-3

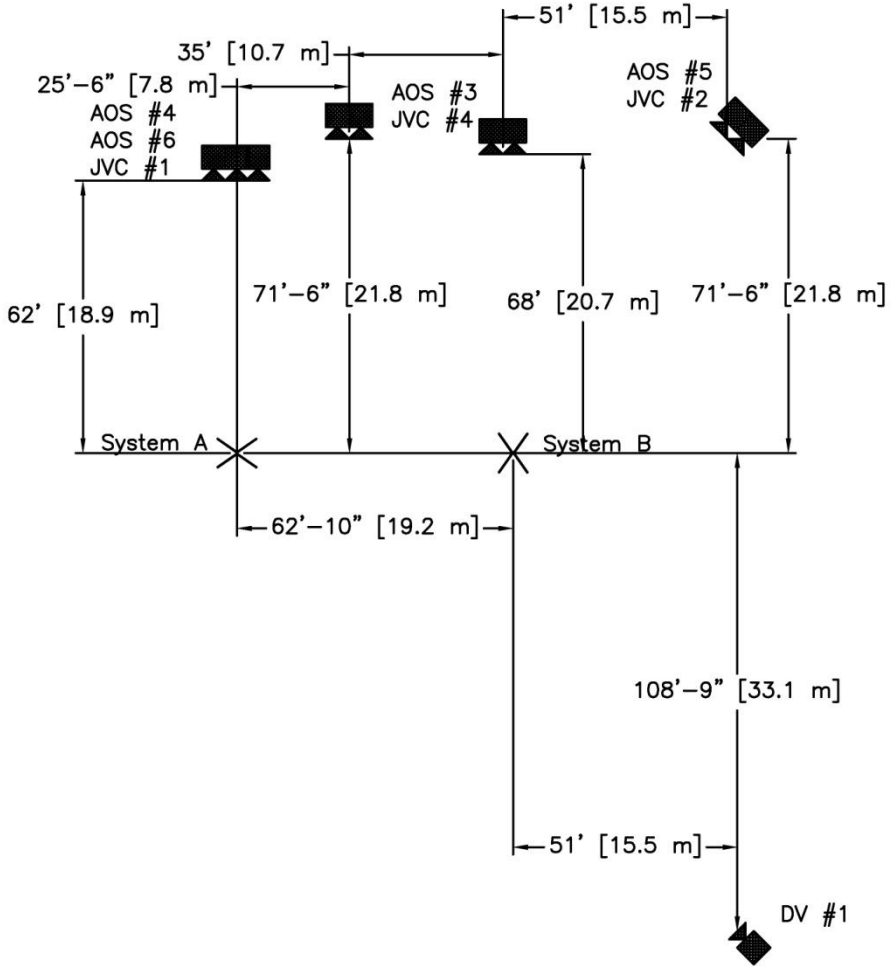

	No.	Type	Operating Speed (frames/sec)	Lens	Lens Setting
High-Speed Video	3	AOS VITcam CTM	500	Cosmicar 12.5 mm fixed	-
	4	AOS VITcam CTM	500	Sigma 24-125 mm	135
	5	AOS X-PRI	500	Tamron 100-300 mm	135
	6	AOS X-PRI	500	Sigma 24-70 mm	50
	7	AOS X-PRI	500	Fujinon 50 mm fixed	-
Digital Video	1	JVC - GZ-MC500 (Everio)	29.97		
	2	JVC - GZ-MG27u (Everio)	29.97		
	3	JVC - GZ-MG27u (Everio)	29.97		
	4	JVC - GZ-MG27u (Everio)	29.97		
	1	Canon-ZR90	29.97		

Figure 44. Camera Locations, Speeds, and Lens Settings, Test No. WZ09-4

8 FULL-SCALE CRASH TEST NO. WZ09-1 (SYSTEM NOS. 1A AND 1B)

8.1 Test No. WZ09-1

The 5,159-lb (2,340-kg) pickup truck with a simulated occupant seated in the right-front seat impacted System No. 1A, a work-zone sign support oriented end-on to the vehicle, at a speed of 63.4 mph (102.1 km/h) and at an angle of 90 degrees. The pickup truck then impacted System No. 1B, a work-zone sign support oriented end-on to the vehicle, at a speed of 62.0 mph (99.8 km/h) and at an angle of 90 degrees. A summary of the test results and sequential photographs are shown in Figures 45 and 46. Additional sequential photographs are shown in Figures 47 and 48. Documentary photographs of the crash test are shown in Figure 49.

8.2 Weather Conditions

Test no. WZ09-1 was conducted on April 22, 2009 at approximately 1:30 pm. The weather conditions, as per the National Oceanic and Atmospheric Administration (station 14939/LNK), were documented and are shown in Table 13.

Table 13. Weather Conditions, Test No. WZ09-1

Temperature	80° F
Humidity	22%
Wind Speed	0 mph
Wind Direction	0° from True North
Sky Conditions	Sunny
Visibility	10 Statute Miles
Pavement Surface	Dry
Previous 3-Day Precipitation	0.0 in.
Previous 7-Day Precipitation	0.3 in.

8.3 Test Description

For System No. 1A, initial vehicle impact was to occur with the centerline of the mast 2 in. (51 mm) to the left of the right-side quarter point on the pickup truck's bumper, as shown in Figure 50. The actual point of impact was with the centerline of the mast 5½ in. (140 mm) to the

left of the right-side quarter point. For System No. 1B, initial vehicle impact was to occur with the centerline of the impact-side mast 2 in. (51 mm) to the right of the left-side quarter point on the pickup truck’s bumper, as shown in Figure 51. The actual point of impact was with the centerline of the mast 2 in. (51 mm) to the right of the left-side quarter point.

A sequential description of the impact events for test no. WZ09-1A is shown in Table 14. Approximately 0.580 seconds after the first impact, the second impact occurred. A sequential description of the impact events for test no. WZ09-1B is shown in Table 15. The vehicle came to rest 567 ft – 6 in. (173.0 m) downstream from the second impact and 22 ft – 10 in. (6.9 m) laterally toward the left of the second impact. The vehicle trajectory and final position are shown in Figures 45, 46, and 52.

Table 14. Sequential Description of Impact Events, Test No. WZ09-1A

TIME (sec)	EVENT
0	Front bumper impacted the mast of System No. 1A
0.004	The mast fractured away from the base
0.008	The bottom of sign released from the bracket, and the upper mast started bending
0.010	Sign panel began to fall and two flags detached from the flag holder
0.012	Truck traversed over the legs
0.046	Sign panel impacted windshield, and mast rotated toward the truck
0.050	Top of sign panel impacted roof
0.088	Sign disengaged from the mast at the upper bracket
0.096	Third flag disengaged as the mast continued to rotate toward the vehicle
0.128	The flag holder penetrated the roof
0.144	Sign panel disengaged from the roof of the vehicle
0.176	The flag holder disengaged from the roof, and the mast rotated over the truck

Table 15. Sequential Description of Impact Events, Test No. WZ09-1B

TIME (sec)	EVENT
0	Front bumper impacted the mast of System No. 1B
0.004	Impact-side leg fractured
0.006	Sign panel began rotating as impact-side mast bent around front of hood
0.014	Sign panel bent at its vertical center
0.020	Impacted mast contacted non-impacted mast
0.028	Non-impact side leg fractured
0.080	Sign panel corner contacted windshield
0.084	Sign stand became completely airborne
0.104	Light contacted upper-left corner of windshield and roof
0.122	Impact-side mast lost contact with the hood and pushed the light through windshield
0.160	Sign panel reached maximum bending
0.320	Sign panel lost contact with the windshield and rotated off the right side of the truck

8.4 System and Component Damage

Damage to System Nos. 1A and 1B is shown in Figures 53 through 56. System No. 1A encountered severe damage to the sign support stand. Two of the four legs were still attached to the base but were not in their original positions. One of the attached legs was bent moderately, and the other was bent slightly. The other two legs were fractured completely at the leg release/lock mechanism and were slightly bent. The angled base plates attaching the legs were bent, and the plate above the springs was slightly bent. The lower mast was fractured at the breakaway holes. The upper mast was slightly bent. The upper rigid bracket was significantly deformed outwards. All corners of the sign panel were dented and scratched. All three flags were undamaged, and one was located in the bed of the pickup truck.

System No. 1B encountered moderate damage. The impact-side leg fractured at the vertical stub and was bent onto itself. The non-impact side leg fractured at the vertical stub and was bent moderately. The impact-side mast was dented above the outer sleeve. The bottom of the

non-impact side outer sleeve, mast, and vertical sleeve had a crease and were dented in. Tearing in the sign panel occurred at both bottom bolt locations. The sign panel was bent around the attached light. A slight bend occurred in the impact-side mast around the bottom bolt. Scratches were found on the warning light, and glass pieces were embedded in the plastic light box.

8.5 Vehicle Damage

Vehicle damage is shown in Figures 57 and 58. The bumper was dented inward where it contacted System Nos. 1A and No. 1B. Small scuffs were found on the plastic bumper on the right side and at both impact locations. The upper-right side of the grill was scratched. The left corner of the grill was broken, and the engine hood sustained a cut at the left-side impact location. The hood was pushed backward and upward at the left-front corner, and the left-front half of the hood was scratched. The windshield was sliced through at the center of the right target where it was contacted by the sign panel from System No. 1A. The upper-center windshield contained a large hole along the roofline where the sign panel of System No. 1B impacted. Another large hole occurred in the upper-left corner of the windshield where the light and mast of System No. 1B impacted. Significant windshield indentation and cracking occurred. The roof was dented and encountered scratches at the right-side impact location. Small dents were found in the front of the roof at the left-side impact location. A small hole was observed in the middle of the roof and slightly off center to the right side where the flag holder of System No. 1B impacted.

Maximum windshield indentation was 13 in. (330 mm) on the right side from System No. 1A and 9 in. (229 mm) on the left side from System No. 1B. Maximum roof crush was 3¾ in. (95 mm) at the roof edge of the windshield on the right side from System No. 1A. A complete description of vehicle deformations and the corresponding locations are provided in Appendix E.

8.6 Occupant Risk

Occupant impact velocities and maximum 0.010-sec occupant ridedown accelerations were not calculated due to the small change in velocity during the impacts. The recorded data from the accelerometers and the rate transducers are shown graphically in Appendix F. No meaningful data was captured by the EDR-3 in test no. WZ09-1.

8.7 Discussion

Following test no. WZ09-1, a safety performance evaluation was conducted, and the performance of System No. 1A was determined to be unacceptable according to the MASH criteria. It was deemed unacceptable due to the flag holder penetrating the roof, the sign panel penetrating the windshield, windshield indentation greater than 3 in. (76 mm), and significant windshield cracking. Deformations of, and intrusion into, the occupant compartment did occur as System No. 1A penetrated into the occupant compartment on the right side of the windshield when the corner of the sign panel sliced through the windshield and also when the metal flag holder penetrated the roof into the occupant compartment.

System No. 1B was also determined to be unacceptable according to the MASH criteria due to the light and mast penetrating the windshield, windshield indentation greater than 3 in. (76 mm), and significant windshield cracking, which caused the obstruction of driver visibility and the loss of structure in both glass layers in the windshield. Deformations of, and intrusion into, the occupant compartment did occur as System No. 1B penetrated into the occupant compartment near the upper-center region and upper-left corner of the windshield when the light, mast, and sign panel contacted the windshield. The vehicle's trajectory did not intrude into adjacent traffic lanes.

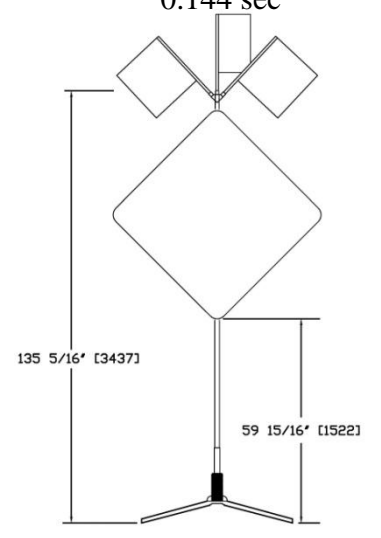
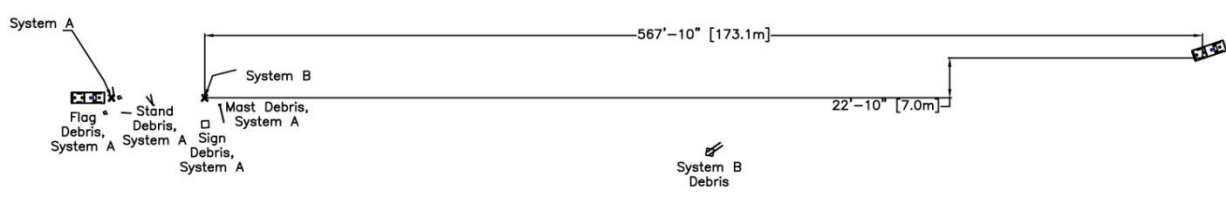

- Test Agency.....MwRSF
- Test Number.....WZ09-1A
- Date4/22/09
- MASH Test Designation Number.....3-72
- Test Article.....Portable Sign Support
 - Height to Bottom of Sign.....59¹⁵/₁₆ in. (1,522 mm)
 - Mast Material.....Aluminum Tubing
- Key Component – X-Footprint Base
 - Length.....125½ in. (3,188 mm)
 - Width.....47½ in. (1,207 mm)
- Key Component – Aluminum Sign Panel
 - Dimension.....48 in. x 48 in. (1,219 mm x 1,219 mm)
 - Thickness.....0.074 in. (1.9 mm)
- Vehicle Make and Model.....2002 Dodge Ram 1500 Quad Cab Pickup
 - Curb.....5,119 lb (2,322 kg)
 - Test Inertial.....4,990 lb (2,263 kg)
 - Gross Static.....5,159 lb (2,340 kg)
- Impact Conditions
 - Speed.....63.4 mph (102.0 km/h)
 - Angle.....90 deg
 - Impact Location.....centerline of mast
- Exit Conditions
 - Angle.....90 deg

- Vehicle Stability.....Satisfactory
- Vehicle Stopping Distance (longitudinal).....567 ft - 6 in. (173.0 m) from Impact B
- Vehicle Stopping Distance (lateral).....22 ft - 10 in. (6.9 m) left of Impact B
- Maximum Angular Displacements (EDR-4)
 - Yaw.....1.20 deg
 - Pitch.....-0.41 deg
 - Roll.....0.84 deg
- Vehicle Damage.....Severe Windshield Damage
 - VDS^[33].....12-FR-1
 - CDC^[34].....12FRAN1
 - Maximum Interior Deformation.....NA
- Test Article Damage.....Moderate

Figure 45. Summary of Test Results and Sequential Photographs, Test No. WZ09-1A



0.000 sec

0.028 sec

0.080 sec

0.104 sec

0.160 sec

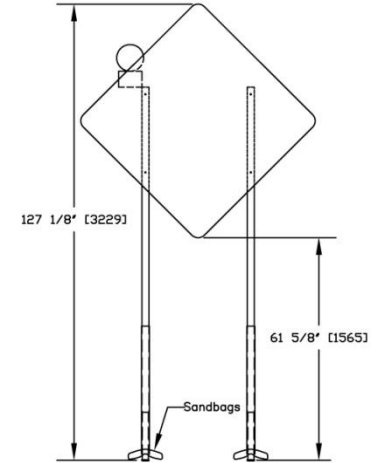
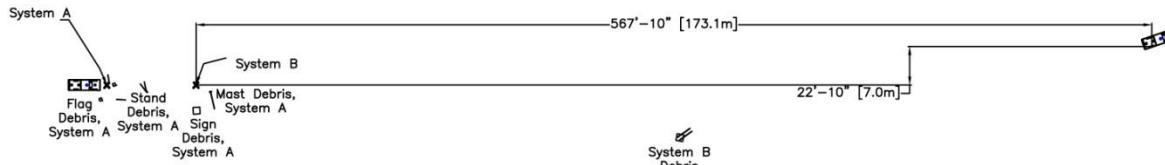

- Test Agency MwRSF
- Test Number WZ09-1B
- Date 4/22/09
- MASH Test Designation Number 3-72
- Test Article Portable Sign Support
 - Height to Bottom of Sign 61 5/8 in. (1,565 mm)
 - Mast Material Telespar Steel Tubing
- Key Component – H-Footprint Base
 - Length 72 in. (1,829 mm)
 - Width 25 7/16 in. (646 mm)
- Key Component – Aluminum Sign Panel
 - Dimension 48 in. x 48 in. (1,219 mm x 1,219 mm)
 - Thickness 0.075 in. (1.9 mm)
- Key Component – Ballast
 - Weight 4 – 50 lb (22.7 kg) sandbags
- Vehicle Make and Model 2002 Dodge Ram 1500 Pickup
 - Curb 5,119 lb (2,322 kg)
 - Test Inertial 4,990 lb (2,263 kg)
 - Gross Static 5,159 lb (2,340 kg)
- Impact Conditions
 - Speed 62.0 mph (99.8 km/h)
 - Angle 90 deg
 - Impact Location centerline of mast

- Exit Conditions
 - Angle 90 deg
- Vehicle Stability Satisfactory
- Vehicle Stopping Distance (longitudinal) 567 ft - 6 in. (173.0 m) from Impact B
- Vehicle Stopping Distance (lateral) 22 ft - 10 in. (6.9 m) left of Impact B
- Maximum Angular Displacements (EDR-4)
 - Yaw -1.51 deg
 - Pitch -0.34 deg
 - Roll -1.05 deg
- Vehicle Damage Severe Windshield Damage
 - VDS^[33] 12-FL-1
 - CDC^[34] 12FYAN1
 - Maximum Interior Deformation NA
- Test Article Damage Moderate

Figure 46. Summary of Test Results and Sequential Photographs, Test No. WZ09-1B



0.000 sec



0.018 sec



0.050 sec



0.102 sec



0.144 sec



0.380 sec



Figure 47. Additional Sequential Photographs, Test No. WZ09-1A



0.000 sec



0.020 sec



0.064 sec



0.104 sec



0.180 sec



0.272 sec



Figure 48. Additional Sequential Photographs, Test No. WZ09-1B



Figure 49. Documentary Photographs, Test No. WZ09-1



Figure 50. Impact Location, Test No. WZ09-1A



Figure 51. Impact Location, Test No. WZ09-1B

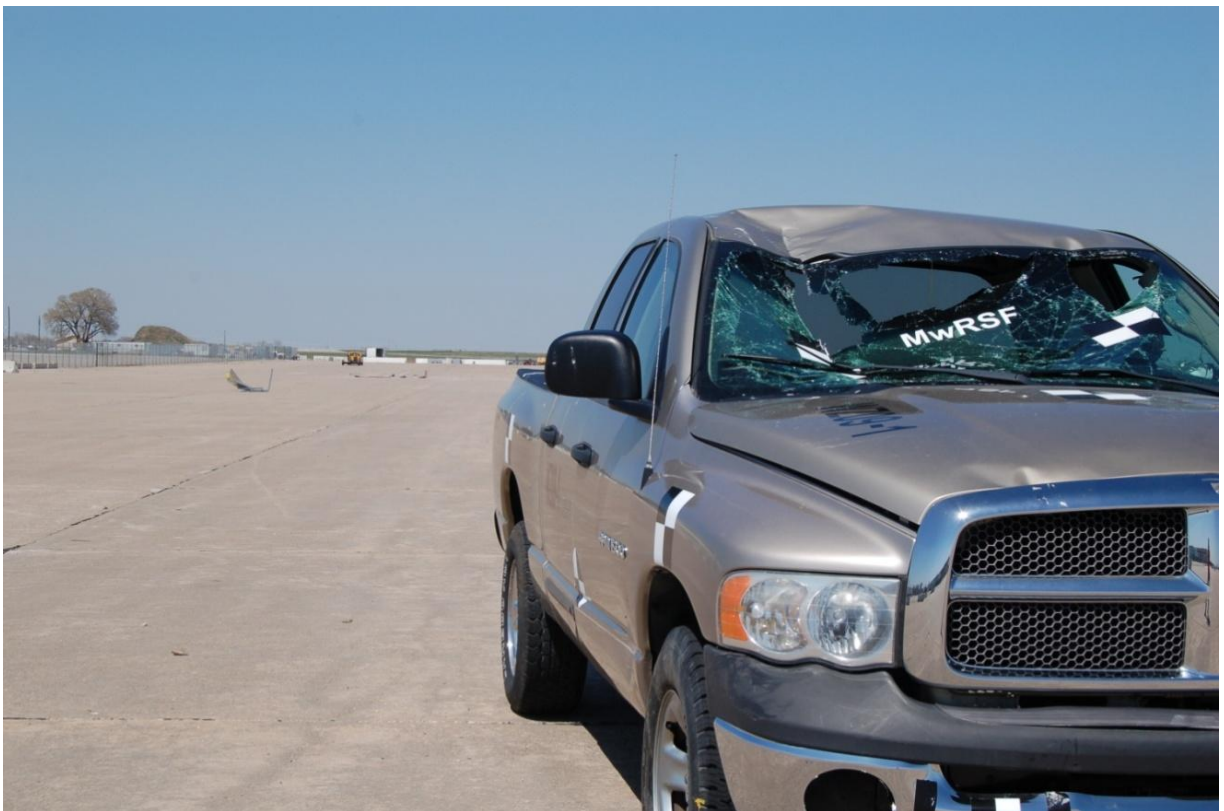

Figure 52. Vehicle Final Position and Trajectory Marks, Test No. WZ09-1

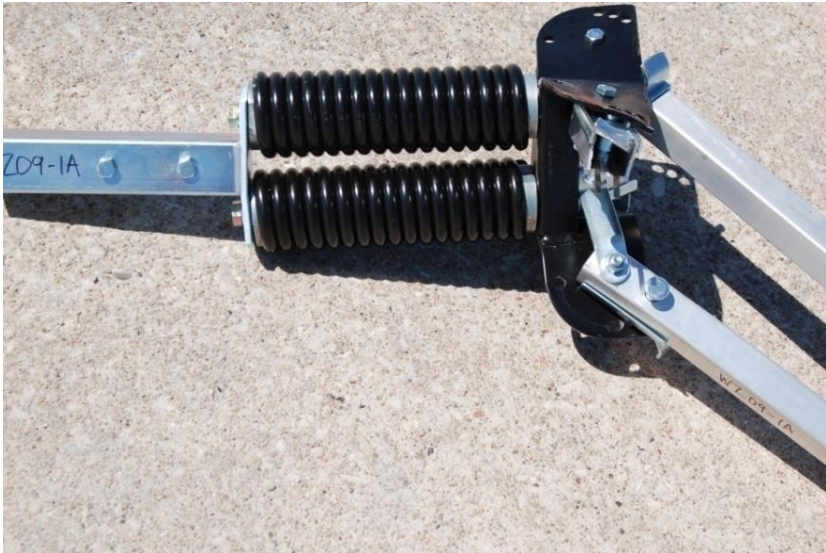

Figure 53. System Damage, Test No. WZ09-1A

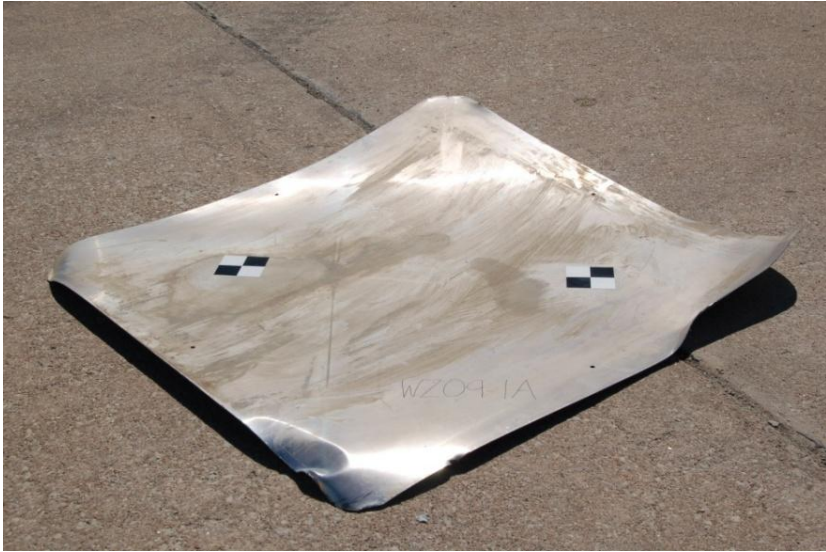

Figure 54. System Damage, Test No. WZ09-1A



Figure 55. System Damage, Test No. WZ09-1B

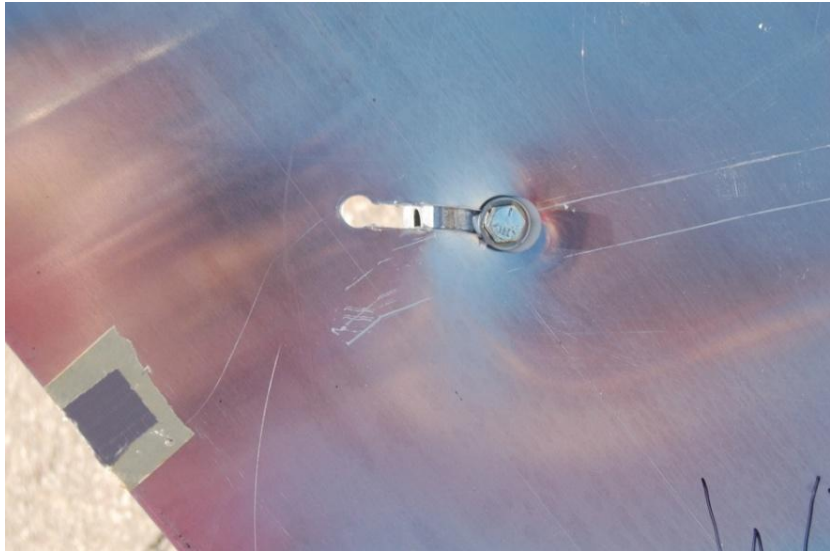
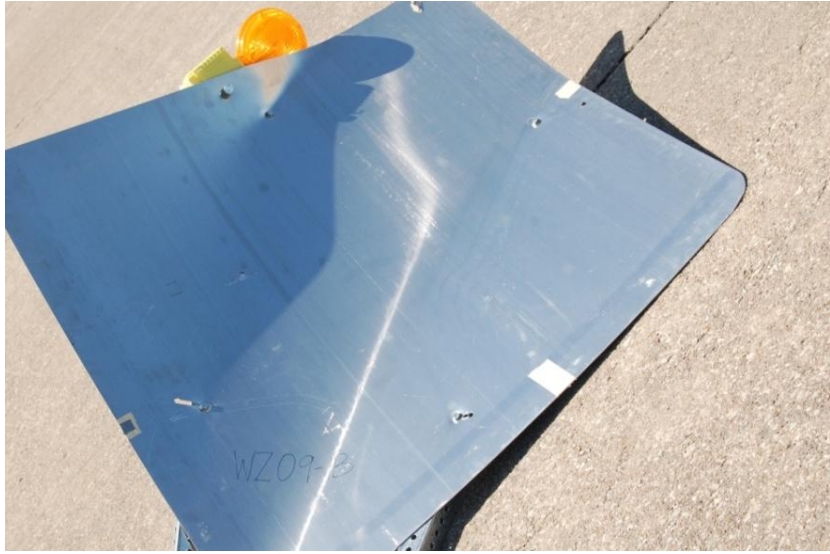

Figure 56. System Damage, Test No. WZ09-1B



Figure 57. Vehicle Damage, Test No. WZ09-1



Figure 58. Vehicle Damage, Test No. WZ09-1

9 FULL-SCALE CRASH TEST NO. WZ09-2 (SYSTEM NOS. 2A AND 2B)

9.1 Test No. WZ09-2

The 2,573-lb (1,167-kg) small car with a simulated occupant seated in the right-front seat impacted System No. 2A, a work-zone sign support oriented head-on to the vehicle, at a speed of 64.1 mph (103.2 km/h) and at an angle of 0 degrees. The small car then impacted System No. 2B, a work-zone sign support oriented end-on to the vehicle, at a speed of 61.4 mph (98.8 km/h) and at an angle of 90 degrees. A summary of the test results and sequential photographs are shown in Figures 59 and 60. Additional sequential photographs are shown in Figures 61 and 62. Documentary photographs of the crash test are shown in Figure 63.

9.2 Weather Conditions

Test no. WZ09-2 was conducted on May 28, 2009 at approximately 12:30 pm. The weather conditions, as per the National Oceanic and Atmospheric Administration (station 14939/LNK), were documented and are shown in Table 16.

Table 16. Weather Conditions, Test No. WZ09-2

Temperature	77° F
Humidity	31%
Wind Speed	9 mph
Wind Direction	340° from True North
Sky Conditions	Sunny
Visibility	10 Statute Miles
Pavement Surface	Dry
Previous 3-Day Precipitation	0.32 in.
Previous 7-Day Precipitation	0.61 in.

9.3 Test Description

For System No. 2A, initial vehicle impact was to occur with the centerline of the mast at the right-side quarter point on the car's bumper, as shown in Figure 64. The actual point of impact was 3 in. (76 mm) to the left of the right-side quarter point. For System No. 2B, initial

vehicle impact was to occur with the center of the sign panel at the left-side quarter point on the car's bumper, as shown in Figure 65. The actual point of impact was at the left-side quarter point. A sequential description of the impact events for test no. WZ09-2A is shown in Table 17. Approximately 0.678 seconds after the first impact, the second impact occurred. A sequential description of the impact events for test no. WZ09-2B is shown in Table 18. The vehicle came to rest 285 ft – 8 in. (87.1 m) downstream from the first impact and 16 ft – 4 in. (5.0 m) laterally towards the left of the first impact. The vehicle trajectory and final position are shown in Figures 59, 60, and 66.

Table 17. Sequential Description of Impact Events, Test No. WZ09-2A

TIME (sec)	EVENT
0	Front bumper impacted the mast of System No. 2A
0.002	Mast began buckling as the car overrode it, and the sign panel contacted hood and began dragging across it
0.008	Mast fractured near impact height
0.010	Base was traversed over, the mast rotated toward the car, and the lower rigid bracket released from mast
0.012	Base became wedged under the car and traveled along with the car
0.016	Two flag staffs fractured and disengaged from the mast
0.044	Sign panel impacted the lower windshield and pushed the impact flash bulb into the windshield
0.052	Windshield glass disengaged from flash bulb impact
0.078	Rearview mirror became detached and fell into the occupant compartment
0.102	Top edge of sign panel detached from the bracket, and the mast rotated over the car
0.110	Sign panel lost contact with the windshield as glass disengaged from the windshield
0.180	Sign panel lost contact with the roof, and the mast continued to rotate
0.212	Lower mast separated from the upper mast
0.292	Third flag disengaged as the mast continued to rotate

Table 18. Sequential Description of Impact Events, Test No. WZ09-2B

TIME (sec)	EVENT
0	Left headlight and quarter panel impacted the sign panel and impact-side leg of System No. 2B
0.002	Impact-side leg began to deform and moved downstream, and the lower impact-side edge of the sign panel began to deform
0.004	Bumper impacted sandbag and began to crush backward from the sign panel impact
0.008	Sign panel began to rotate into the hood of the car
0.010	Front impact-side leg became airborne
0.012	Rear leg became airborne
0.014	Front non-impact side leg became airborne
0.022	Non-impact side flag staff fractured
0.030	Impact-side flag staff fractured
0.050	Bottom of sign detached from base and began to bend upward
0.064	Top bracket impacted windshield and penetrated into the occupant compartment as the sign panel began to deform around left A-pillar
0.122	Mast was parallel with the ground and continued to rotate backward off to the left side of the car
0.216	Sign panel became fully detached from the tripod

9.4 System and Component Damage

Damage to System Nos. 2A and 2B is shown in Figures 67 through 70. System No. 2A encountered severe damage to the sign support stand. The lower mast fractured at the breakaway holes and landed upstream of the impact. The base, with all four legs attached, remained intact under the car. The angled plate attaching two of the legs was bent and torn at one of the bolt holes. The other angled plate's corner was deformed and crushed from dragging. Both coil springs were significantly deformed and bent over. The upper rigid bracket deformed out. The flag holders were slightly bent, and the bottoms of two flag staffs were fractured. The upper mast was bent slightly. The lower rigid bracket was slightly deformed out. The sign panel was deformed out with a crease at the top corner from the rigid panel bracket.

System No. 2B encountered moderate damage. The stand remained intact with the windshield until the termination of braking. Two legs were bent slightly, but all three legs remained intact with the bolt plates. The bolts in the upper bolt plate were fractured. The upper bolt plate was deformed out. Both flag staffs fractured, and the ends of the staffs were located inside the car. The sandbag tore, but the rope remained attached to the stand and the bag. The panel was slightly deformed with tears and scratches.

9.5 Vehicle Damage

Vehicle damage is shown in Figures 71 and 72. The left side of the front plastic bumper was scuffed and cut where it contacted System No. 2B, and it was deformed outward from the left-front quarter panel. The lower-left side of the plastic bumper was deformed backward and torn. The left headlight was fractured. The left-front quarter panel was dented at the front. The left-front corner of the hood was deformed down. The right side of the engine hood and roof were scuffed from the sign panel of System No. 2A. A concentrated point of impact was found at the bottom-right corner of the windshield from the flash bulb deforming into the windshield. A large hole was found at the top of the windshield slightly to the left of center where the upper rigid bracket and mast of System No. 2B impacted. The entire windshield encountered cracking with severe cracking at the upper half of the windshield. The rearview mirror disengaged from the windshield, and glass was found on both the front and back seats.

Maximum windshield indentation was 2¼ in. (57 mm) on the right side from System No. 2A and 7¾ in. (197 mm) on the left side from System No. 2B. Maximum roof crush was ¾ in. (19 mm) on the left side. A complete description of vehicle deformations and the corresponding locations are provided in Appendix E.

9.6 Occupant Risk

Occupant impact velocities and maximum 0.010-sec occupant ridedown accelerations were not calculated due to the small change in velocity during the impacts. The recorded data from the accelerometers and the rate transducers are shown graphically in Appendix G.

9.7 Discussion

Following test no. WZ09-2, a safety performance evaluation was conducted, and the performance of System No. 2A was determined to be successful according to the MASH criteria. The windshield damage from System Nos. 2A and 2B overlapped at the middle third of the windshield, but the damage to the right third of the windshield was specifically from System No. 2A. A concentrated point of impact from the flash bulb on the lower windshield, and not the test article, occurred in the lower-right corner of the windshield. All other cracking and indentation on the right side of the windshield was from the test article. Detached elements and debris from System No. 2A contacted the windshield, and moderate cracking occurred. A maximum deformation of 2¼ in. (57 mm) occurred on the right side of the windshield, which is below the 3 in. (76 mm) maximum value defined in MASH. There was no penetration of the windshield and no tear in the plastic liner. Moderate windshield cracking also occurred along the upper-right two-thirds of the windshield when the sign panel from System No. 2A released and impacted the windshield, as determined from high-speed video analysis. The cracking appeared to be the same at the upper-middle region of the windshield as well as to the right side. The maximum deformations at the top of the windshield are unknown due to overlapping damage with System No. 2B, but the deformations were less than 3 in. (76 mm). Therefore, the system performance was determined to be acceptable.

System No. 2B was determined to be unacceptable according to the MASH criteria due to significant windshield cracking, windshield indentation greater than 3 in. (76 mm), and windshield penetration. Deformations of, and intrusion into, the occupant compartment did occur as System No. 2B penetrated into the occupant compartment near the upper-center region of the windshield when the mast contacted the windshield. Even though the mast impacted the top of the windshield, which was already weakened from the impact with System No. 2A, the penetration was significant and was believed to have occurred without the prior damage. The vehicle's trajectory did not intrude into adjacent traffic lanes.



0.000 sec

0.010 sec

0.044 sec

0.110 sec

0.180 sec

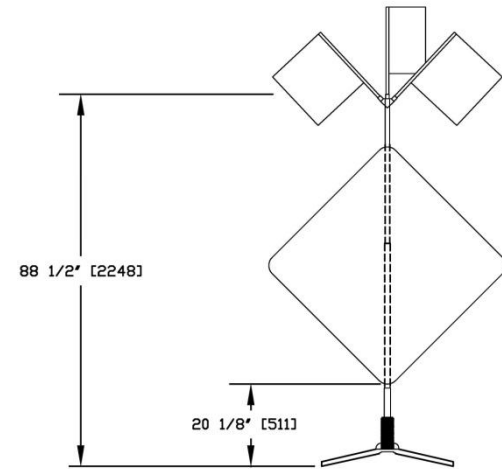
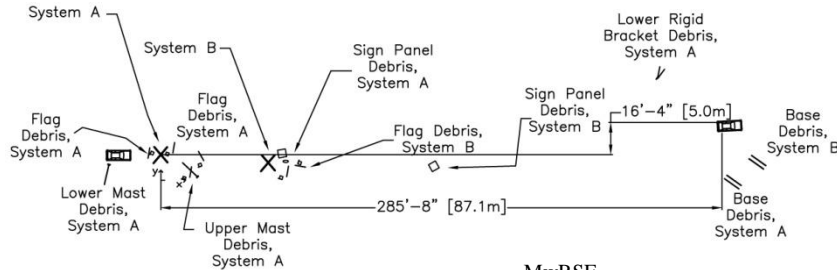

145

- Test Agency MwRSF
- Test Number WZ09-2A
- Date 5/28/09
- MASH Test Designation Number 3-71
- Test Article Portable Sign Support
 - Height to Bottom of Sign 20 1/8 in. (511 mm)
 - Mast Material Aluminum Tubing
- Key Component – X-Footprint Base
 - Length 84 3/4 in. (2,143 mm)
 - Width 32 3/4 in. (832 mm)
- Key Component – Aluminum Sign Panel
 - Dimension 48 in. x 48 in. (1,219 mm x 1,219 mm)
 - Thickness 0.075 in. (1.9 mm)
- Vehicle Make and Model 2002 Kia Rio Sedan
 - Curb 2,309 lb (1,047 kg)
 - Test Inertial 2,404 lb (1,090 kg)
 - Gross Static 2,573 lb (1,167 kg)
- Impact Conditions
 - Speed 64.1 mph (103.2 km/h)
 - Angle 0 deg
 - Impact Location centerline of mast
- Exit Conditions
 - Angle 0 deg

- Vehicle Stability Satisfactory
- Vehicle Stopping Distance (longitudinal) 285 f t- 8 in. (87.1 m) from Impact A
- Vehicle Stopping Distance (lateral) 16 ft - 4 in. (5.0 m) left of Impact A
- Maximum Angular Displacements (DTS)
 - Yaw -2.08 deg
 - Pitch 3.90 deg
 - Roll -1.02 deg
- Vehicle Damage Moderate Windshield Damage
 - VDS^[33] 12-FR-1
 - CDC^[34] 12FZAW1
 - Maximum Interior Deformation NA
- Test Article Damage Severe

Figure 59. Summary of Test Results and Sequential Photographs, Test No. WZ09-2A



0.000 sec

0.022 sec

0.050 sec

0.064 sec

0.122 sec

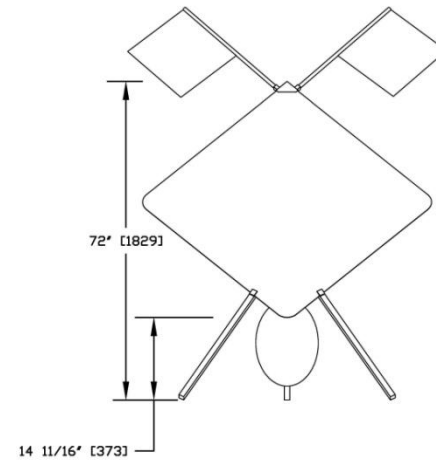
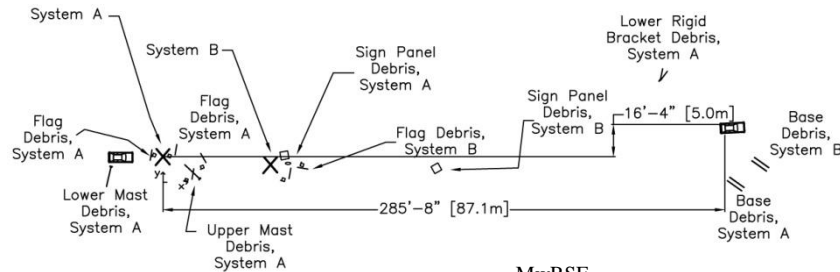

- Test Agency MwRSF
- Test Number WZ09-2B
- Date 5/28/09
- MASH Test Designation Number 3-71
- Test Article Portable Sign Support
 - Height to Bottom of Sign 14¹¹/₁₆ in. (373 mm)
 - Base Material Steel Tubing
- Key Component – Tripod Base
 - Length 56⁵/₁₆ in. (1,430 mm)
 - Width 48³/₄ in. (1,238 mm)
- Key Component – Ballast
 - Weight 50 lb (22.7 kg) sandbag
- Key Component – Aluminum Sign Panel
 - Dimension 48 in. x 48 in. (1,219 mm x 1,219 mm)
 - Thickness 0.080 in. (2.0 mm)
- Vehicle Make and Model 2002 Kia Rio Sedan
 - Curb 2,309 lb (1,047 kg)
 - Test Inertial 2,404 lb (1,090 kg)
 - Gross Static 2,573 lb (1,167 kg)
- Impact Conditions
 - Speed 61.4 mph (98.8 km/h)
 - Angle 90 deg
 - Impact Location centerline of sign panel

- Exit Conditions
 - Angle 90 deg
- Vehicle Stability Satisfactory
- Vehicle Stopping Distance (longitudinal) 285 ft - 8 in. (87.1 m) from Impact A
- Vehicle Stopping Distance (lateral) 16 ft - 4 in. (5.0 m) left of Impact A
- Maximum Angular Displacements (DTS)
 - Yaw 3.06 deg
 - Pitch 2.55 deg
 - Roll 0.89 deg
- Vehicle Damage Severe Windshield Damage
 - VDS^[33] 12-FL-1
 - CDC^[34] 12FYAN1
 - Maximum Interior Deformation NA
- Test Article Damage Moderate

Figure 60. Summary of Test Results and Sequential Photographs, Test No. WZ09-2B



0.000 sec



0.112 sec



0.006 sec



0.156 sec



0.036 sec



0.200 sec



0.110 sec



0.230 sec



0.242 sec



0.368 sec



0.380 sec



0.440 sec

Figure 61. Additional Sequential Photographs, Test No. WZ09-2A



0.000 sec



0.016 sec



0.020 sec



0.066 sec



0.076 sec



0.216 sec

Figure 62. Additional Sequential Photographs, Test No. WZ09-2B



Figure 63. Documentary Photographs, Test No. WZ09-2



Figure 64. Impact Location, Test No. WZ09-2A



Figure 65. Impact Location, Test No. WZ09-2B



Figure 66. Vehicle Final Position and Trajectory Marks, Test No. WZ09-2



Figure 67. System Damage, Test No. WZ09-2A



Figure 68. System Damage, Test No. WZ09-2A



Figure 69. System Damage, Test No. WZ09-2B



Figure 70. System Damage, Test No. WZ09-2B



Figure 71. Vehicle Damage, Test No. WZ09-2



Figure 72. Vehicle Damage, Test No. WZ09-2

10 FULL-SCALE CRASH TEST NO. WZ09-3 (SYSTEM NOS. 3A AND 3B)

10.1 Test No. WZ09-3

The 2,575-lb (1,168-kg) small car with a simulated occupant seated in the right-front seat impacted System No. 3A, a work-zone sign support oriented head-on to the vehicle, at a speed of 66.0 mph (106.1 km/h) and at an angle of 0 degrees. The small car then impacted System No. 3B, a work-zone sign support oriented end-on to the vehicle, at a speed of 62.7 mph (100.9 km/h) and at an angle of 90 degrees. A summary of the test results and sequential photographs are shown in Figures 73 and 74. Additional sequential photographs are shown in Figures 75 through 77. Documentary photographs of the crash test are shown in Figure 78.

10.2 Weather Conditions

Test no. WZ09-3 was conducted on September 14, 2009 at approximately 2:45 pm. The weather conditions, as per the National Oceanic and Atmospheric Administration (station 14939/LNK), were documented and are shown in Table 19.

Table 19. Weather Conditions, Test No. WZ09-3

Temperature	77° F
Humidity	47%
Wind Speed	6 mph
Wind Direction	160° from True North
Sky Conditions	Partly Sunny
Visibility	10 Statute Miles
Pavement Surface	Dry
Previous 3-Day Precipitation	0.16 in.
Previous 7-Day Precipitation	0.25 in.

10.3 Test Description

For System No. 3A, initial vehicle impact was to occur with the centerline of the mast at the right-side quarter point on the car's bumper, as shown in Figure 79. The actual point of impact was 1½ in. (38 mm) to the left of the right-side quarter point. For System No. 3B, initial

vehicle impact was to occur with the centerline of the mast at the left-side quarter point on the car's bumper, as shown in Figure 80. The actual point of impact was at the left-side quarter point.

A sequential description of the impact events for test no. WZ09-3A is shown in Table 20. Approximately 0.640 seconds after the first impact, the second impact occurred. A sequential description of the impact events for test no. WZ09-3B is shown in Table 21. The vehicle came to rest 445 ft – 2 in. (135.7 m) downstream from the first impact and 5 ft – 8 in. (1.7 m) laterally towards the right of the first impact. The vehicle trajectory and final position are shown in Figures 73, 74, and 81.

Table 20. Sequential Description of Impact Events, Test No. WZ09-3A

TIME (sec)	EVENT
0	Front bumper impacted the mast of System No. 3A
0.002	Vertical coil springs deflected backward
0.004	Bottom of the sign panel released from the rigid bracket
0.006	The sign panel contacted the top of the grill
0.010	Non-impact side legs deformed, and all the flags disengaged from the flag holder
0.014	Lower mast fractured at the base tube
0.018	Sign panel traversed across the hood
0.038	Sign panel contacted windshield, and the flash bulb deformed into the windshield
0.052	Top of the sign panel released from the rigid bracket
0.054	Sign panel contacted the roof
0.070	Sign panel became attached to the windshield
0.080	Top of the mast contacted the back of the sign panel above the roof
0.120	Mast rotated over the car

Table 21. Sequential Description of Impact Events, Test No. WZ09-3B

TIME (sec)	EVENT
0	Front bumper impacted the impact-side base tube of System No. 3B
0.002	Base tubes deflected downstream, and the bumper contacted the sign panel
0.004	The sign panel disengaged from the bottom rigid bracket
0.006	The top of the upper stage of the mast deflected upstream
0.010	Impact-side legs lost contact with ground, and the non-impact side legs deformed
0.010	Upper mast separated from the lower rigid bracket sleeve
0.014	Car began to traverse over the base
0.028	Horizontal crossbrace end contacted the windshield
0.068	Lower rigid bracket sleeve separated from the base
0.110	Horizontal crossbrace end contacted the roof as the mast and sign panel rotated over the car
0.150	Non-impact side flag disengaged from the flag holder
0.278	Stand contacted the rear bumper of the vehicle
0.432	Impact-side flag disengaged from the flag holder

10.4 System and Component Damage

Damage to System Nos. 3A and 3B is shown in Figures 82 through 85. System No. 3A encountered moderate damage. The three flags released from the flag holder. Both springs were deformed to a horizontal position. The front of base plate deformed inward, and the front legs were pushed closer together. The lower mast completely fractured at the top of bolt side plates and was crushed at the fracture point. The lower mast aluminum was torn below the fracture point at one corner. The sign panel remained intact with the car, and reflective material was scraped on the front face. The sign panel was also deformed outward with a small hole near the top. Damage to the concrete surface around the original location of System No. 3A included gouges 2½ ft (0.8 m) downstream of the impact, where the bottom part of the lower mast contacted the concrete.

System No. 3B encountered moderate damage. The two flags released from the flag holder. One leg completely fractured at the locking bolt. One leg was deformed slightly outward, and another leg was deformed significantly outward. The upper mast and sign panel remained intact. Scuff marks were found on the back of the sign panel and on the vertical and horizontal crossbracing around the roll-up bracket. The sign panel was torn around the lower vertical fiberglass pocket. The outer sleeve fractured just above the bolt, and the corners of the lower rigid bracket and bracket sleeve were scuffed. The angled base plates were deformed outward and scuffed on the corners. The base tubes crushed inward and twisted slightly, and the lower part of the outer sleeve was crushed below the fracture point.

10.5 Vehicle Damage

Vehicle damage is shown in Figures 86 and 87. The lower and upper plastic front bumpers were fractured at both the left- and right-side impact locations. The bolts underneath the car were scuffed on the left and right sides. The left front of the engine hood was dented and scraped, and black scuff marks were found on the left side of the hood. Minor scraping occurred along the right side of the hood. Significant windshield cracking occurred with a concentrated point of impact from the right-side flash bulb deforming into the windshield. Orange reflective material was embedded in the windshield cracks on the right side. A hole was found in the upper-middle region of the windshield where the rearview mirror was attached. A small scrape was found on the right-front roof, and minor scuffing occurred along the right side of the roof.

Maximum windshield indentation was 4 in. (102 mm) on the right side from System No. 3A and 2 ¼ in. (57 mm) on the left side from System No. 3B. There was no significant roof deformation. A complete description of vehicle deformations and the corresponding locations are provided in Appendix E.

10.6 Occupant Risk

The calculated occupant impact velocities (OIVs) and maximum 0.010-sec occupant ridedown accelerations (ORAs) in both the longitudinal and lateral directions are shown in Table 22. It is noted that the OIVs and ORAs were within the suggested limits provided in MASH. The calculated THIV and PHD values are also shown in Table 22. The results of the occupant risk analysis, as determined from the accelerometer data, are summarized in Figures 73 and 74. The recorded data from the accelerometers and the rate transducers are shown graphically in Appendix H.

Table 22. Summary of OIV, ORA, THIV, and PHD Values, Test No. WZ09-3

Evaluation Criteria		Transducer			
		WZ09-3A		WZ09-3B	
		EDR-3	DTS	EDR-3	DTS
OIV ft/s (m/s)	Longitudinal	NA	-9.15 (-2.79)	NA	-3.88 (-1.18)
	Lateral	NA	0.14 (0.04)	NA	-0.39 (-0.12)
ORA g's	Longitudinal	NA	0.77	NA	0.79
	Lateral	NA	0.79	NA	0.43
THIV ft/s (m/s)		NA	9.28 (2.83)	NA	3.94 (1.20)
PHD g's		NA	0.95	NA	0.84

NA – Flail space model did not detect occupant impact

10.7 Discussion

Following test no. WZ09-3, a safety performance evaluation was conducted, and the performance of System No. 3A was determined to be unacceptable according to the MASH criteria. It was deemed unacceptable due to significant windshield cracking and windshield

indentation greater than 3 in. (76 mm). Deformations of the occupant compartment did occur as the sign panel from System No. 3A contacted and indented the windshield a maximum of 4 in. (102 mm). The top of the mast contacted the back of the sign panel that was intact with the windshield and roof and left a small hole in the panel. In the event that the sign panel releases from the windshield, there is a potential for the mast to contact and penetrate the roof.

System No. 3B was determined to be acceptable according to the MASH criteria since the maximum deformation on the left side of the windshield was only 2¼ in. (57 mm). Windshield cracking was insufficient to cause obstruction of visibility, and the horizontal fiberglass crossbrace did not appear to have the potential for windshield penetration. The vehicle's trajectory did not intrude into adjacent traffic lanes.



0.000 sec

0.006 sec

0.038 sec

0.080 sec

0.120 sec

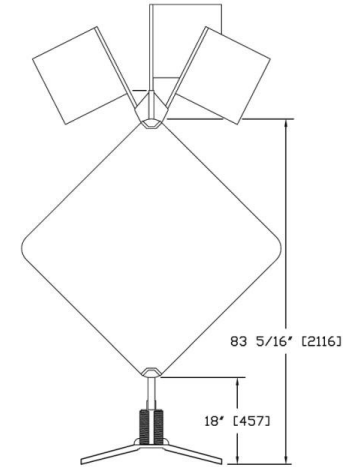
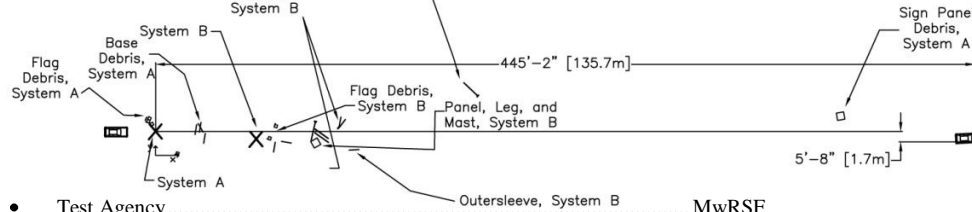

- Test Agency MwRSF
- Test Number WZ09-3A
- Date 9/14/09
- MASH Test Designation Number 3-71
- Test Article Portable Sign Support
 - Height to Bottom of Sign 18 in. (457 mm)
 - Mast Material Aluminum Tubing
- Key Component – X-Footprint Base
 - Length 81¾ in. (2,076 mm)
 - Width 40⁷/₁₆ in. (1,027 mm)
- Key Component – Aluminum Sign Panel
 - Dimension 48 in. x 48 in. (1,219 mm x 1,219 mm)
 - Thickness 0.093 in. (2.4 mm)
- Vehicle Make and Model 2002 Kia Rio Sedan
 - Curb 2,309 lb (1,047 kg)
 - Test Inertial 2,404 lb (1,090 kg)
 - Gross Static 2,573 lb (1,167 kg)
- Impact Conditions
 - Speed 66.0 mph (106.1 km/h)
 - Angle 0 deg
 - Impact Location centerline of mast
- Exit Conditions
 - Angle 0 deg
- Vehicle Stability Satisfactory
- Vehicle Stopping Distance (longitudinal) 445 ft - 2 in. (135.7 m) from Impact A
- Vehicle Stopping Distance (lateral) 5 ft - 8 in. (1.7 m) right of Impact A

- Occupant Ridedown Acceleration (DTS)
 - Longitudinal 0.77 g's < 20.49 g's
 - Lateral 0.79 g's < 20.49 g's
- Occupant Impact Velocity (DTS)
 - Longitudinal -9.15 ft/s (-2.79 m/s) < 16.4 ft/s (5.0 m/s)
 - Lateral 0.14 ft/s (0.04 m/s) < 16.4 ft/s (5.0 m/s)
- THIV (DTS – not required) 9.28 ft/s (2.83 m/s)
- PHD (DTS – not required) 0.95 g's
- Maximum Angular Displacements (DTS)
 - Yaw 4.59 deg
 - Pitch -3.84 deg
 - Roll 1.23 deg
- Vehicle Damage Severe Windshield Deformation
 - VDS^[33] 12-FR-1
 - CDC^[34] 12FZAW1
 - Maximum Interior Deformation NA

Figure 73. Summary of Test Results and Sequential Photographs, Test No. WZ09-3A

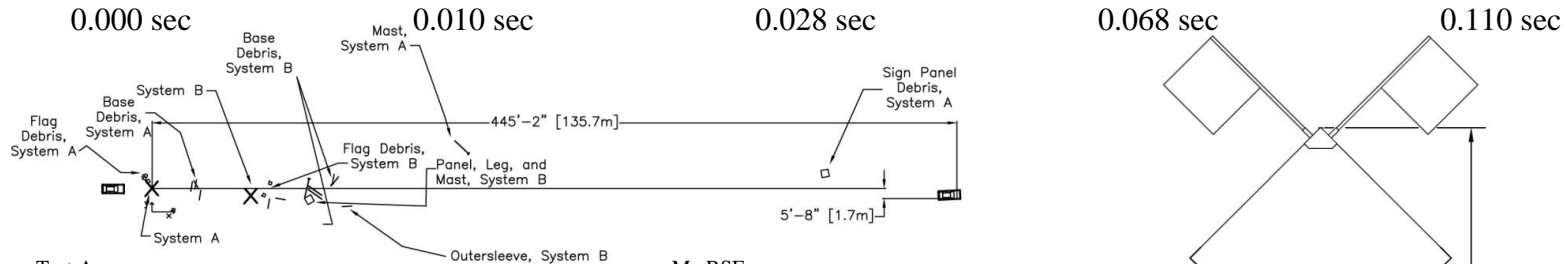

- Test Agency MwRSF
- Test Number WZ09-3B
- Date 9/14/09
- MASH Test Designation Number 3-71
- Test Article Portable Sign Support
 - Height to Bottom of Sign 21 in. (533 mm)
 - Base Material Steel Tubing
- Key Component – X-Footprint Base
 - Length 92 1/16 in. (2,338 mm)
 - Width 45 11/16 in. (1,160 mm)
- Key Component – Vinyl Roll-up Sign Panel
 - Dimension 48 in. x 48 in. (1,219 mm x 1,219 mm)
 - Thickness 0.026 in. (0.7 mm)
- Vehicle Make and Model 2002 Kia Rio Sedan
 - Curb 2,309 lb (1,047 kg)
 - Test Inertial 2,404 lb (1,090 kg)
 - Gross Static 2,573 lb (1,167 kg)
- Impact Conditions
 - Speed 62.7 mph (100.9 km/h)
 - Angle 90 deg
 - Impact Location centerline of mast
- Exit Conditions
 - Angle 90 deg
- Vehicle Stability Satisfactory
- Vehicle Stopping Distance (longitudinal) 445 ft - 2 in. (135.7 m) from Impact A
- Vehicle Stopping Distance (lateral) 5 ft - 8 in. (1.7 m) right of Impact A

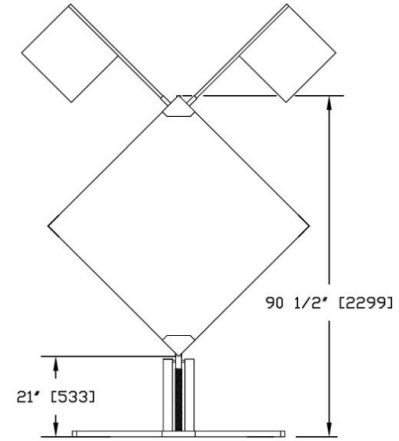

- Occupant Ridedown Acceleration (DTS)
 - Longitudinal 0.79 g's < 20.49 g's
 - Lateral 0.43 g's < 20.49 g's
- Occupant Impact Velocity (DTS)
 - Longitudinal -3.88 ft/s (-1.18 m/s) < 16.4 ft/s (5.0 m/s)
 - Lateral -0.39 ft/s (-0.12 m/s) < 16.4 ft/s (5.0 m/s)
- THIV (DTS – not required) 3.94 ft/s (1.20 m/s)
- PHD (DTS – not required) 0.84 g's
- Maximum Angular Displacements (DTS)
 - Yaw 3.22 deg
 - Pitch 1.47 deg
 - Roll -2.64 deg
- Vehicle Damage Moderate Windshield Deformation
 - VDS^[33] 12-FL-1
 - CDC^[34] 12FLAN1
 - Maximum Interior Deformation NA
- Test Article Damage Moderate

Figure 74. Summary of Test Results and Sequential Photographs, Test No. WZ09-3B



0.000 sec



0.640 sec



0.012 sec



0.652 sec



0.034 sec



0.666 sec



0.054 sec



0.692 sec



0.142 sec



0.730 sec



0.246 sec



0.774 sec

Figure 75. Additional Sequential Photographs, Test No. WZ09-3

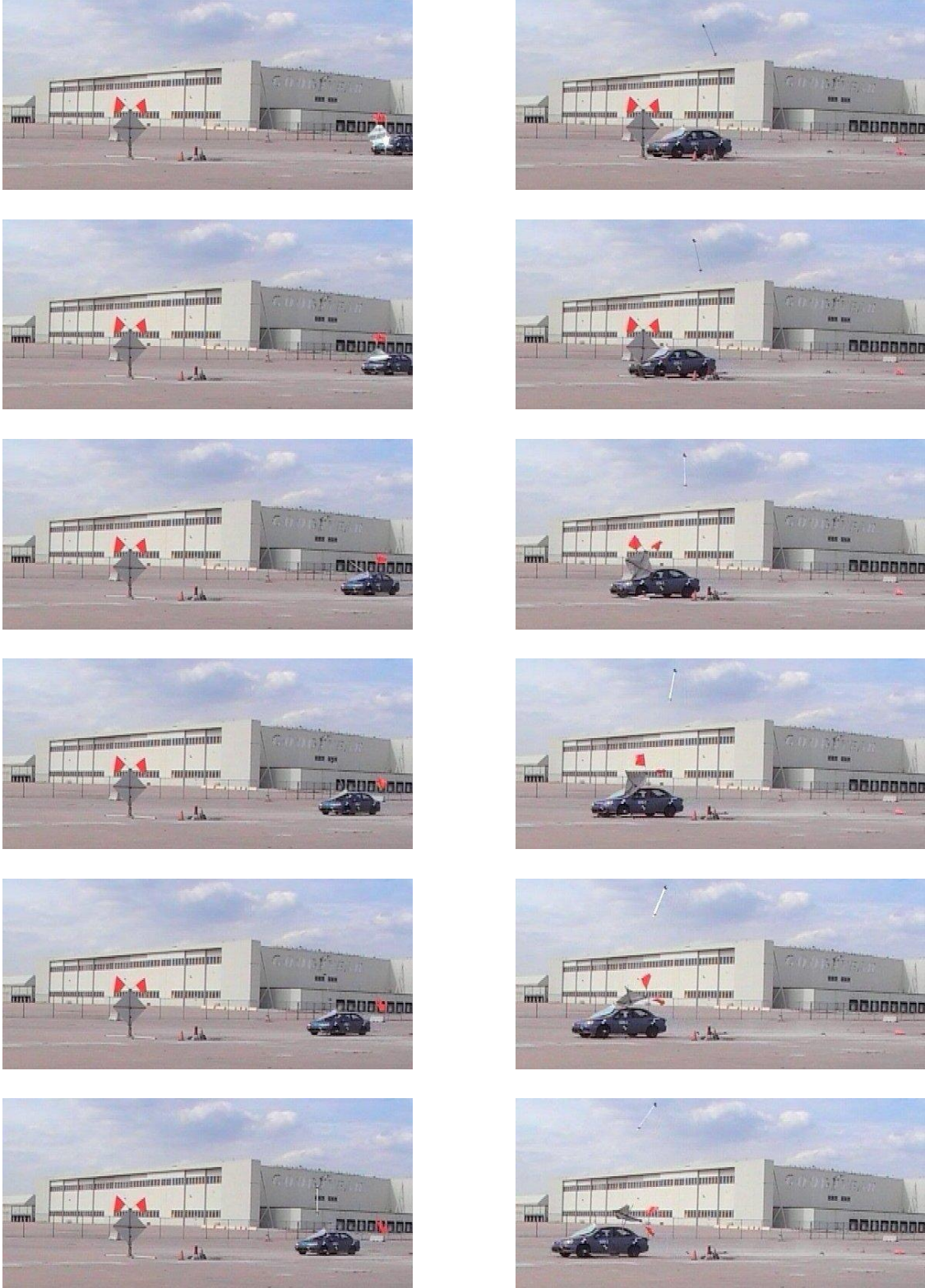

Figure 76. Additional Sequential Photographs, Test No. WZ09-3



0.000 sec



0.012 sec



0.020 sec

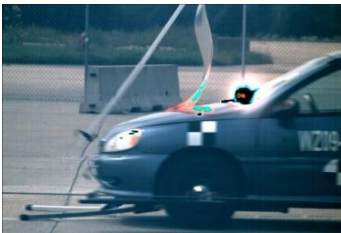

0.026 sec



0.032 sec



0.062 sec

Figure 77. Additional Sequential Photographs, Test No. WZ09-3A



Figure 78. Documentary Photographs, Test No. WZ09-3



Figure 79. Impact Location, Test No. WZ09-3A



Figure 80. Impact Location, Test No. WZ09-3B



Figure 81. Vehicle Final Position and Trajectory Marks, Test No. WZ09-3



Figure 82. System Damage, Test No. WZ09-3A



Figure 83. System Damage, Test No. WZ09-3A



Figure 84. System Damage, Test No. WZ09-3B



177

Figure 85. System Damage, Test No. WZ09-3B



Figure 86. Vehicle Damage, Test No. WZ09-3



179

Figure 87. Vehicle Damage, Test No. WZ09-3

11 FULL-SCALE CRASH TEST NO. WZ09-4 (SYSTEM NOS. 4A AND 4B)

11.1 Test No. WZ09-4

The 5,157-lb (2,339-kg) pickup truck with a simulated occupant seated in the right-front seat impacted System No. 4A, a work-zone sign support oriented head-on to the vehicle, at a speed of 65.8 mph (105.9 km/h) and at an angle of 0 degrees. The pickup truck then impacted System No. 4B, a work-zone sign support oriented end-on to the vehicle, at a speed of 64.4 mph (103.7 km/h) and at an angle of 90 degrees. A summary of the test results and sequential photographs are shown in Figures 88 and 89. Additional sequential photographs are shown in Figures 90 and 91. Documentary photographs of the crash test are shown in Figure 92.

11.2 Weather Conditions

Test no. WZ09-4 was conducted on September 16, 2009 at approximately 12:00 pm. The weather conditions, as per the National Oceanic and Atmospheric Administration (station 14939/LNK), were documented and are shown in Table 23.

Table 23. Weather Conditions, Test No. WZ09-4

Temperature	80° F
Humidity	41%
Wind Speed	5 mph
Wind Direction	80° from True North
Sky Conditions	Sunny
Visibility	10 Statute Miles
Pavement Surface	Dry
Previous 3-Day Precipitation	0.0 in.
Previous 7-Day Precipitation	0.16 in.

11.3 Test Description

For System No. 4A, initial vehicle impact was to occur with the centerline of the mast at the right-side quarter point on the pickup truck's bumper, as shown in Figure 93. The actual point of impact was 1½ in. (38 mm) to the left of the right-side quarter point. For System No. 4B,

initial vehicle impact was to occur with the centerline of the mast to the right of the left-side quarter point on the pickup truck’s bumper, as shown in Figure 94. The actual point of impact was 2 in. (51 mm) to the right of the left-side quarter point.

A sequential description of the impact events for test no. WZ09-4A is shown in Table 24. Approximately 0.61 seconds after the first impact, the second impact occurred. A sequential description of the impact events for test no. WZ09-4B is shown in Table 25. The vehicle came to rest 432 ft – 2 in. (131.7 m) downstream from the first impact and 88 ft – 8 in. (27.0 m) laterally towards the right of the first impact. The vehicle trajectory and final position are shown in Figures 88, 89, and 95.

Table 24. Sequential Description of Impact Events, Test No. WZ09-4A

TIME (sec)	EVENT
0	Front bumper impacted the lower mast of System No. 4A
0.006	Top of the sign panel detached from the roll-up sign holder
0.014	Connection between the lower and upper mast failed
0.016	First flag staff fractured in the flag holder
0.026	Sign panel impacted the hood of the truck
0.028	Second flag staff fractured in the flag holder
0.048	Front legs impacted the undercarriage of the vehicle
0.070	Flag holder impacted the windshield
0.076	Flag holder impacted the roof
0.078	Flag holder disengaged from the mast
0.080	Third flag staff fractured in the flag holder

Table 25. Sequential Description of Impact Events, Test No. WZ09-4B

TIME (sec)	EVENT
0	Grill impacted the sign panel of System No. 4B
0.002	Upper mast began to bend
0.008	Sign panel crushed the hood
0.016	The sign panel impacted the front bumper
0.022	Sign panel disengaged from the lower rigid bracket
0.024	Front bumper impacted the lower mast
0.036	Left-front tire traversed over the impact-side legs
0.038	Upper and lower mast connections failed
0.058	Sign panel disengaged from the upper rigid bracket
0.072	Upper mast rotated above the windshield
0.144	Upper mast rotated above the roof

11.4 System and Component Damage

Damage to System Nos. 4A and 4B is shown in Figures 96 through 99. System No. 4A encountered severe damage. All three flag staffs fractured at the top of the flag holder, and the ends remained intact with the flag holder. The vertical crossbracing tore through the top of sign panel. The upper mast was bent slightly and separated from the lower mast. The flag holder separated from the upper mast and had scratches and denting on one corner. The base was carried underneath the truck the entire time. One leg penetrated the floorboard and was bent significantly. One leg was wedged behind the right-front wheel and was bent slightly. The lower mast almost completely fractured 1½ in. (38 mm) above the top bent plates. The springs deformed to a horizontal position and were scraped on their sides. All legs released from their original lock positions.

System No. 4B encountered moderate damage. Both bent angle plates were deformed. All legs were released from their original lock positions. One leg was dented slightly, and another leg was bent significantly. Scraping occurred on the sides of the springs, and the springs

were deformed slightly near their bottoms. The lower mast fractured 1½ in. (38 mm) above the top bent plates. The upper mast separated from the lower mast with no damage. The lower rigid bracket separated and was deformed significantly and crushed. The sign panel was crushed inward at the impact-side corner.

11.5 Vehicle Damage

Vehicle damage is shown in Figures 100 and 101. The bumper was dented inward where it contacted System No. 4A and where it contacted System No. 4B. The grill was sliced at the upper-left region. The left front of the engine hood was dented inward and sliced. Scraping occurred on the right-front corner of the hood. A small dent was found in the right-front corner of the hood, and a scratch was found down the right side of the hood. A concentrated tear occurred in the upper-right corner of the windshield where it was contacted by the flag holder from System No. 4A. Two hairline cracks were found beginning at the lower-left corner of the windshield and spanning to the upper-right corner of the windshield. A dent and a scratch were found at the right-front region of the roof. A small hole was found in the floorboard on the left side with one of the legs of System No. 4A protruding through it. The right-front tire was deflated, and one leg of System No. 4A was wedged behind the right-front tire. The front bumper was pushed down and scuffed from a secondary impact with a concrete barrier prior to stopping.

Maximum windshield indentation was ¾ in. (9.5 mm) in the upper-right corner. There was no significant roof deformation. A complete description of vehicle deformations and the corresponding locations are provided in Appendix E.

11.6 Occupant Risk

Occupant impact velocities and maximum 0.010-sec occupant ridedown accelerations were not calculated due to the small change in velocity during the impacts. The recorded data

from the accelerometers and the rate transducers are shown graphically in Appendix I. Due to technical difficulties, the DTS unit did not collect acceleration data, but it did collect angular data from the rate transducer.

11.7 Discussion

Following test no. WZ09-4, a safety performance evaluation was conducted, and the performance of System No. 4A was determined to be unacceptable according to the MASH criteria. It was deemed unacceptable due to the mast penetrating the windshield and a leg penetrating into the occupant compartment. Deformations of, and intrusion into, the occupant compartment did occur as System No. 4A penetrated into the upper-right corner of the windshield and the occupant compartment on the floorboard behind the left-front seat. Also, one of the legs on System No. 4A was wedged behind the right-front tire which inhibited the braking system on the pickup truck. This caused the pickup truck to veer to the right and impact a concrete barrier prior to stopping. This result could be considered a danger to workers in the work-zone area as well as to the occupants of vehicle depending on what objects would have been located to the right side of the roadway.

System No. 4B was determined to be acceptable according to the MASH criteria since the components of System No. 4B did not contact the pickup truck's windshield or roof. Deformations of, and intrusion into, the occupant compartment did not occur, and System No. 4B did not show any potential for occupant compartment penetration. The impact with System No. 4B did not affect the vehicle's trajectory.

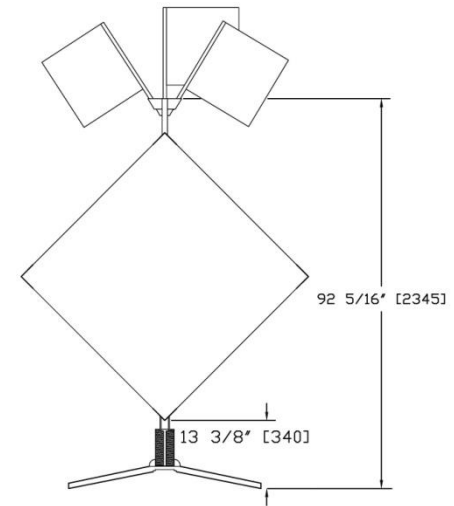
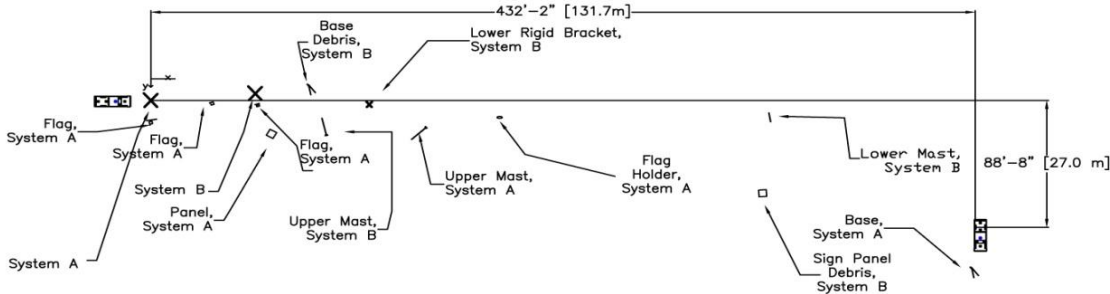

- Test AgencyMwRSF
- Test NumberWZ09-4A
- Date9/16/09
- MASH Test Designation Number3-72
- Test Article Portable Sign Support
 - Height to Bottom of Sign 13 3/8 in. (340 mm)
 - Mast MaterialSteel Tubing
- Key Component – X-Footprint Base
 - Length 79 1/2 in. (2,019 mm)
 - Width 38 15/16 in. (989 mm)
- Key Component – Vinyl Roll-up Sign Panel
 - Dimension48 in. x 48 in. (1,219 mm x 1,219 mm)
 - Thickness 0.028 in. (0.7 mm)
- Vehicle Make and Model2002 Dodge Ram 1500 Quad Cab Pickup
 - Curb5,119 lb (2,322 kg)
 - Test Inertial4,990 lb (2,263 kg)
 - Gross Static5,159 lb (2,340 kg)
- Impact Conditions
 - Speed65.8 mph (105.9 km/h)
 - Angle 0 deg
 - Impact Locationcenterline of mast
- Exit Conditions
 - Angle 0 deg

- Vehicle Stability Satisfactory
- Vehicle Stopping Distance (longitudinal)432 ft - 2 in. (131.7 m) from Impact A
- Vehicle Stopping Distance (lateral)88 ft - 8 in. (27.0 m) right of Impact A
- Maximum Angular Displacements (DTS)
 - Yaw 1.17 deg
 - Pitch2.07 deg
 - Roll3.97 deg
- Vehicle Damage Windshield Penetration/Floorboard Penetration
 - VDS^[33] 12-FR-1
 - CDC^[34] 12FRGN1
 - Maximum Interior DeformationNA
- Test Article DamageSevere

Figure 88. Summary of Test Results and Sequential Photographs, Test No. WZ09-4A

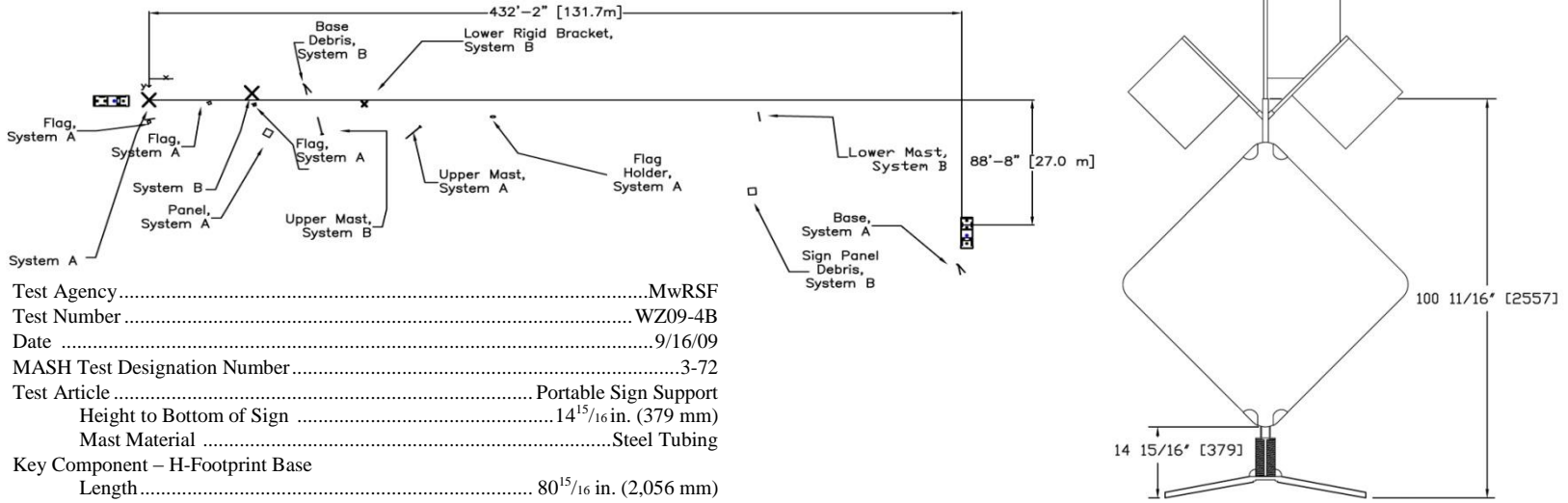

- Test AgencyMwRSF
- Test Number WZ09-4B
- Date 9/16/09
- MASH Test Designation Number3-72
- Test Article Portable Sign Support
 - Height to Bottom of Sign 14¹⁵/₁₆ in. (379 mm)
 - Mast MaterialSteel Tubing
- Key Component – H-Footprint Base
 - Length 80¹⁵/₁₆ in. (2,056 mm)
 - Width 39³/₄ in. (1,010 mm)
- Key Component – Aluminum Sign Panel
 - Dimension48 in. x 48 in. (1,219 mm x 1,219 mm)
 - Thickness 0.093 in. (2.4 mm)
- Vehicle Make and Model2002 Dodge Ram 1500 Quad Cab Pickup
 - Curb5,119 lb (2,322 kg)
 - Test Inertial4,990 lb (2,263 kg)
 - Gross Static5,159 lb (2,340 kg)
- Impact Conditions
 - Speed64.4 mph (103.7 km/h)
 - Angle 90 deg
 - Impact Locationcenterline of mast
- Exit Conditions
 - Angle 90 deg

- Vehicle Stability Satisfactory
- Vehicle Stopping Distance (longitudinal)432 ft - 2 in. (131.7 m) from Impact A
- Vehicle Stopping Distance (lateral)88 ft - 8 in. (27.0 m) right of Impact A
- Maximum Angular Displacements (DTS)
 - Yaw -1.38 deg
 - Pitch -2.01 deg
 - Roll -0.61 deg
- Vehicle DamageMinor Hood Damage
 - VDS^[33] 12-FL-1
 - CDC^[34] 12-FLLU1
 - Maximum Interior DeformationNA
- Test Article Damage Moderate

Figure 89. Summary of Test Results and Sequential Photographs, Test No. WZ09-4B



0.000 sec



0.610 sec



0.016 sec



0.618 sec



0.046 sec



0.632 sec



0.078 sec



0.652 sec



0.088 sec



0.656 sec



0.178 sec



0.744 sec

Figure 90. Additional Sequential Photographs, Test No. WZ09-4



0.000 sec



0.020 sec



0.064 sec



0.104 sec



0.180 sec



0.272 sec

Figure 91. Additional Sequential Photographs, Test No. WZ09-4B



Figure 92. Documentary Photographs, Test No. WZ09-4



Figure 93. Impact Location, Test No. WZ09-4A



Figure 94. Impact Location, Test No. WZ09-4B



Figure 95. Vehicle Final Position and Trajectory Marks, Test No. WZ09-4



Figure 96. System Damage, Test No. WZ09-4A



Figure 97. System Damage, Test No. WZ09-4A



Figure 98. System Damage, Test No. WZ09-4B



Figure 99. System Damage, Test No. WZ09-4B



Figure 100. Vehicle Damage, Test No. WZ09-4



Figure 101. Vehicle Damage, Test No. WZ09-4

12 DISCUSSION

Following the analysis of the crash test results for the portable sign support systems, some general observations were made with respect to the following: (1) the vertical position, failure type, and release time of the sign stand's fracture point, breakaway mechanism, or yielding hinge; (2) the stiffness and material of the sign panel; (3) the sign panel attachment mechanism; and (4) the addition of flag and light attachments. The possible hazards to the adjacent traffic and work-zone crews were also found to be significant in rare circumstances.

Stands with excessive stub lengths remaining after impact can potentially catch on the undercarriage of the vehicle and drag along under the vehicle with heavy contact (System No. 4A). When the legs are oriented head-on to the vehicle, the stand can rotate such that the legs contact and penetrate the vehicle's floorboard. Even though the ground clearance is much greater for the pickup truck when compared to the small car, the potential for penetration has been shown to be a problem with both vehicles. As shown in Figure 102, when the vertical springs at the base were pushed over, the two front legs of the system were forced upward into the undercarriage of the pickup truck resulting in one leg penetrating the left-side floorboard.

A mast with a frangible base reduces the amount of flex that develops in the sign panel and mast (System Nos. 1A, 2A, 3A, and 4A). This relatively quick release of the mast from the stand allows the sign panel and mast to fall upon the vehicle with little additional force than what normally occurs through the impact event, as shown in Figure 103. However, this force can still be sufficient to cause indentation or penetration of the windshield. On the other hand, when base bending occurs, as shown in Figure 104, the sign panel and the top of mast are accelerated downward into the windshield (System No. 1B). When the mast was unloaded, the sign panel and mast have the tendency to "whip" downward onto the vehicle. In addition, a base-bending



Figure 102. System No. 4A, X-Footprint Base Floorboard Penetration



Figure 103. System No. 3A, Frangible Mast

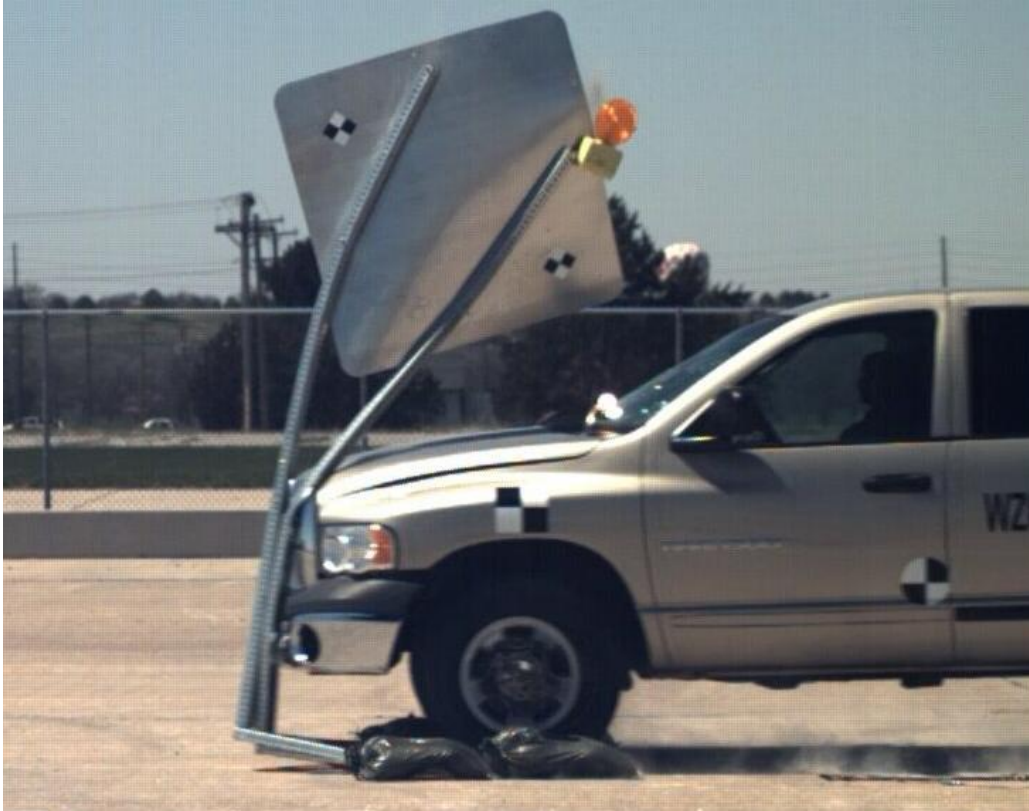

Figure 104. System No. 1B, Base-Bending Mast

mast typically releases from the stand late in the event, if at all, which adds to the amount of flex in the sign panel and mast. When the mast bends or has a delayed fracture, it is more likely that the sign panel or flag assembly will impact the windshield at a high rate of speed. When the connection between the upper and lower masts fails upon impact, the mast and sign panel cause insignificant damage (System Nos. 3B and 4B).

Sign stands that resemble a tripod shape when oriented 90 degrees to the vehicle were found to have a potential to rotate and rise into the air, resulting in the top of the support impacting and penetrating the windshield, as shown in Figure 105 (System No. 2B). Since the legs and mast were not intended to breakaway or yield significantly, the motion and weight of the entire system had the potential for significant windshield damage.



Figure 105. System No. 2B, Tripod Oriented at 90 Degrees

Thinner 0.08-in. (2-mm) aluminum sign panels that were connected to the mast with rigid brackets were found to disengage easily upon impact from the brackets (System Nos. 1A, 2A, 3A, and 4B). In some cases, the release of the sign panel may be detrimental to the safety performance evaluation (System Nos. 1A, 2A, and 3A), whereas in other instances, the release of the sign panel may be beneficial to the safety performance evaluation (System No. 4B). The thicker 0.10-in. (3-mm) aluminum panels (System No. 1B) and the thinner 0.08-in. (2-mm) aluminum panels (System No. 2B) remained attached to the mast if the sign locking mechanism did not allow the panel to disengage upon impact. When this occurs, the additional weight of the aluminum panels allows the systems to impact the vehicle with an additional impulse, often causing windshield penetration (System Nos. 1B and 2B).

Many of the wood-dowel flags disengaged from the flag holder without contacting the vehicle (System Nos. 1A, 3A, and 3B). In some cases, the lack of flags left the flag holder or

mast end exposed with the potential to rotate into and penetrate the roof, as shown in Figure 106 (System Nos. 1A). Some of the wood dowels fractured in their holders, thus disengaging the flags. However, the flags and the exposed flag holder did not show any potential for vehicle damage (System No. 2A). Some flag holders did not disengage the flags upon impact; therefore, these flags and holders followed the trajectory of the mast (System No. 4B). Most of the time, the addition of flags did not negatively affect the safety performance of a work-zone traffic control device. However, if the wood dowels fracture as the flag holder or mast penetrates the windshield, the fractured ends become flying debris and a potential hazard to the occupants of vehicles (System No. 2B). Fiberglass flag staffs would have performed in a different manner than the wood-dowel flags, but it is unclear what effect they would have on the safety performance of any of the work-zone traffic control devices.



Figure 106. System No. 1A, Flag Holder Penetrating the Roof

Other attachments, such as flashing warning lights, also have the potential for significant windshield damage (System No. 1B). Although windshield penetration could still occur without the presence of a light, the extra weight of the light creates a larger impact force on the windshield thus resulting in more damage.

Finally, following an analysis of the test results, it was evident that the debris from the portable sign support systems tended to be thrown along the path of the impacting vehicle. The relative hazard posed to the traffic and work-zone crews located adjacent to the sign systems is somewhat subjective in nature. Depending on the specific site conditions at which these devices are being used, the sign system debris was determined to be less of a hazard to adjacent traffic and work-zone crews than the moving vehicle itself. In rare cases, the system can become wedged in the undercarriage potentially inhibiting braking and resulting in an uncontrollable vehicle trajectory (System No. 4A). While this reaction is dependent on many factors, such as the impact location and orientation, probable vehicle trajectories after impact should be closely considered for certain work-zone traffic control devices.

12.1 Importance of System Parameters

A parametric analysis was used to predict which sign support system parameters influence the safety performance of work-zone systems evaluated under the MASH criteria. Those predicted to be most important with either test vehicle were sign panel material, height to top of mast, mast stages, mast material, flag staff material, and orientation. The only parameter that was predicted to be important exclusively for the pickup truck was base layout. Parameters that were predicted to be only important for the small car were height to top of flags and the sign locking mechanism. The sign support system parameters were re-evaluated after the full-scale crash tests to determine their actual contribution to system performance.

Three of the sign panels tested with the pickup truck were aluminum, which was predicted to be important. In System No. 1A, the aluminum sign panel was very important to the failure of the system, as a lighter-weight or more flexible panel may not have sliced through the windshield. The aluminum sign panel in System No. 1B flexed significantly which caused the rotation of the sign support into the windshield. Since the aluminum sign panel in System No. 4B was mounted at a low height, the panel did not contact the windshield. In System No. 4A, the vinyl roll-up sign panel and crossbracing did not show any potential for windshield contact. Therefore, only rigid sign panel materials are considered to fall into the most critical category for influencing the safety performance of a system when tested with the pickup truck.

Three of the sign panels tested with the small car were aluminum, which was predicted to be important. The aluminum sign panels in System Nos. 2A and 3A flexed outward and disengaged from the brackets, thus causing major damage to the windshield. The weight and rigidness of the panel caused most of the damage, and a vinyl panel of equivalent size would not be expected to produce significant damage. For System No. 2B, the aluminum sign panel crushed, which rotated the sign support around the engine hood until the panel disengaged from the brackets. The aluminum sign panel added weight to the system, which increased the contact force between the mast and the windshield. In System No 3B, the vinyl sign panel and crossbracing did not show any potential for significant windshield deformation or penetration. Therefore, only rigid sign panel materials are classified as the most critical for failure with the small car. Each rigid sign panel material performs very different. Aluminum can flex, whereas plywood will fracture when subjected to a force. Plywood and aluminum panels both could be critical for failure, and both should be analyzed and tested separately.

Not only is the sign panel material important, the reflective sheeting on the face of the aluminum may decrease the safety performance of a system. System Nos. 2A and 3A were nearly identical sign support systems, except that System No. 2A had a blank aluminum sign panel and System No. 3A had an aluminum sign panel with reflective sheeting. The system with reflective sheeting caused 4 in. (102 mm) of windshield deformation and remained intact with the windshield after the impact, while the system without reflective sheeting only caused 2¼ in. (57 mm) of indentation and the panel slid over the windshield and roof of the vehicle. The friction between the reflective sheeting and the windshield was an additional force during the impact that could have contributed to the additional deformation.

The critical range for the top of mast height was predicted to be 75 to 132 in. (1,905 to 3,353 mm) for the pickup truck. System No. 1A [135⁵/₁₆ in. (3,437 mm) top of mast height] was 3 in. (76 mm) above the critical top of mast height for the pickup truck, but the mast did not show any potential to contact the windshield. The height to the bottom of the sign panel was critical in this case for the sign panel to slice through the windshield. The critical height to top of mast range was determined by the critical predicted methods of failure, most of which were failures by windshield penetration. Thus, increasing the height increases the chance of roof deformation or penetration, which also occurred. System No. 1B [109⁷/₈ in. (2,791 mm) top of mast height] was in the critical range for height to top of mast. This height contributed to the light, mast, and sign panel contacting the windshield, as the deformation of the mast around the hood caused the upper portion of the mast to rotate and push the light and sign panel through the windshield. System No. 4A [92⁵/₁₆ in. (2,345 mm) top of mast height] was at a critical mast height for the mast to penetrate the windshield. The steel flag holder, which was attached to the top of the mast, impacted the windshield causing a ¾-in. (10-mm) localized indentation with a tear in the

windshield's plastic layer for the pickup truck. A lower mast height would increase the chance of windshield penetration, and a taller mast height would decrease the chance of windshield penetration with this system configuration. System No. 4B [100⁵/₁₆ in. (2,557 mm) height to top of mast] had a mast that separated at mid-height, which caused the upper mast to rotate above and clear the pickup truck's windshield and the lower mast to pass under the truck.

All work-zone systems that were crash tested with small cars were in the critical range for height to top of mast, which was predicted to be 59 to 110 in. (1,499 to 2,794 mm). System Nos. 2A [88½ in. (2,248 mm) top of mast height] and 3A [89 in. (2,261 mm) top of mast height] did not show any potential for the mast to strike the windshield. However, the height to the top of mast was found to be dependent on the sign panel mounting height, and the sign panel was at a height where it contacted and caused deformation to the windshield. In System No. 2B [72 in. (1,829 mm) top of mast height], the rigid bracket at the top of the mast contacted and penetrated the windshield, which made this height on a tripod system very critical for failure. The mast in System No. 3B [90½ in. (2,299 mm) top of mast height] separated at mid-height, thus causing the upper mast to rotate above and clear the windshield and the lower mast to pass under the car.

System Nos. 1A, 1B, 4A, and 4B were classified as having 2-stage masts, which was predicted to be critical for the pickup truck vehicle. Even though System No. 1B did not have a telescoping 2-stage mast, it had two vertical masts, each with an outer sleeve similar to a larger dimension lower mast. The number of mast stages was not considered to be as important as the height to top of mast, since the number of stages was directly related to the height to top of mast.

System Nos. 2A, 3A, and 3B had 2-stage masts that were directly related to the height to the top of mast, so the conclusions are the same as those found for the mast height. System No. 2B was a tripod that has a unique mast. It was classified as a single-stage mast, and the mast

definitely caused the failure which was attributed to the height to the top of the mast more-so than the mast stages.

Steel mast material was predicted to be important for the pickup truck. System No. 1A had an aluminum mast which fractured and disengaged quickly. The height of the system and quick fracture of the aluminum mast allowed the mast and sign panel to rotate into and penetrate the windshield. System No. 1B had two steel masts that bent around the hood, thus causing the masts, light, and sign panel to rotate into and penetrate the windshield. Since base bending of the mast occurred rather than fracture, an additional force developed through the flexing of the mast. This behavior caused the sign panel to impact the windshield with a greater force. The lower steel mast in System No. 4A did not break away, which allowed the lower mast and base to become entangled in the undercarriage of the pickup truck, resulting in floorboard penetration. The steel masts in System No. 4B separated at the connection between the upper and lower masts, and resulted in no damage from the mast.

The mast material that was determined to be important for small car failure was also steel. System Nos. 2A and 3A had aluminum masts which fractured and disengaged quickly, so the masts rotated over the windshield and roof. System No. 2B had a steel mast that impacted and penetrated the windshield. In this case, the size and weight of the mast and flag holder assembly contributed to failure. It is expected that an aluminum material also would have caused a failure, since the stiffness of the mast material did not contribute to the failure as much as the size and shape. System No. 3B had a steel mast which did not appear to cause any damage to the car. The general trend in work-zone traffic control devices is that most breakaway masts tend to be made out of aluminum, whereas most non-breakaway masts tend to be steel. So, it is more likely that the breakaway mechanisms in some systems cause quick rotation into the windshield,

and the lack of breakaway mechanisms in other systems cause the mast and base to deform around the hood and later impact the windshield.

Both the use of wood-dowel flags and the nonuse of flags on systems were important for the pickup truck. For this testing, the addition of flags was chosen for traffic control devices for which they were accepted and predicted to be critical by the system analysis. The addition of the flags was subjective in nature. System No. 1A had flags that disengaged and caused no damage, but this left the metal flag holder exposed and, consequently, caused a small hole in the roof of the occupant compartment. The system would have had the same performance with or without the flags, since the flag holder caused the damage. System No. 1B was the only system tested with no flags, and the addition of flags would most likely not have affected the safety performance evaluation. The three flag staffs in System No. 4A all fractured at the flag holder and caused no damage. The exposed flag holder, which separated from the mast, hit the windshield and showed the potential of causing more damage if it would have hit lower on the windshield. All three flags in System No. 4B remained attached to the flag holder and did not cause any damage.

The nonuse of flag staffs was also determined to be important for the small car, but no systems were tested in this configuration due to the results of the system analysis. In System No. 2A, two of the flag staffs fractured and the third disengaged from the holder. The flags and flag holder did not cause any damage nor pose any threat to the occupants. In System No. 2B, the two flag staffs fractured as the upper part of the mast penetrated the windshield, and the ends of the flags staffs were left inside the occupant compartment. The fractured flag staffs were a potential hazard to the occupants as was the flag holder since it penetrated the windshield. System Nos. 3A and 3B had flags that disengaged, thus causing no damage.

No conclusions can be drawn about a specific orientation. Both 0- and 90-degree orientations caused failures in both vehicles. Therefore, orientation became an important parameter when analyzed with a critical combination of other parameters. The 0-degree orientation was found to be the most critical in the analysis, but five systems were tested at the 90-degree orientation. Orientation is not an important parameter independently, since the performance of a system in either orientation is dependent on the combination of other system parameters. Three of the five systems that were tested at the 90-degree orientation (System Nos. 1A, 1B, and 2B) failed the MASH criteria with a critical method of failure. Two of the three systems that were tested at the 0-degree orientation (System Nos. 3A and 4A) failed. The 90-degree orientation with rigid sign panels is very critical when the sharp rigid corners are located at the windshield height.

System No. 1A had an X-footprint base, which was predicted to be a critical base layout with the pickup truck. However, no evidence showed that the base layout contributed to the failure since the truck easily traversed over the base after the mast fractured. System Nos. 4A and 4B also both had X-footprint bases. System No. 1B had a parallel dual upright base. Since only one mast was impacted, it caused the sign panel and opposite mast to rotate toward a 0-degree orientation as it contacted the windshield. This behavior was caused by the parallel dual mast system with no reinforcement between the legs of the base. Although base layout was found to be an important parameter through the parameter analysis, this finding may have occurred because most of the historical crash-tested systems had either X-footprint or parallel dual upright bases, and it is not that important toward the contribution to the observed system failures. The one system with an X-footprint base oriented at 0 degrees (System No. 4A) had a leg that penetrated the floorboard of the pickup truck. Since the legs are intended to fold up for easy

portability, when impacted, the legs tend to release from their locked positions, allowing them to fold up into the undercarriage. This phenomenon does not occur when the system is oriented at 90 degrees (System Nos. 1A and 4B).

For the small car, the nonuse of flags was found to be important in the analysis for the height to top of the flags. No systems were tested without flags, although System No. 2A [111 in. (2,819 mm) top of flags height], System No. 3A [$110^{3/16}$ in. (2,799 mm) top of flags height], and System No. 3B [$113^{5/16}$ in. (2,878 mm) top of flags height] would have performed the same with or without flags since the flags disengaged from the flag holder without any contact to the vehicle. Since an analysis was not conducted on System No. 2B [$87^{7/8}$ in. (2,232 mm) top of flags height], flags were used in this test to replicate a prior test with an 820C small car. The flag staffs in System No. 2B fractured when they impacted the vehicle but did not cause significant damage. The wood-dowel flags did fracture inside the vehicle, thus causing debris which could injure the occupants. The height to the top of the flags was not important since it is a function of the height to the top of the mast. The presence of flags needs to be further analyzed for individual systems to determine whether they are important.

The sign locking mechanism that was important for failure with the small car vehicle was a nut and bolt connection, but this was not tested. Rigid brackets were used to support the aluminum sign panels in System Nos. 2A, 2B, and 3A, and a roll-up bracket was used with the vinyl sign panel in System No. 3B. In System Nos. 2A and 3A, the rigid brackets disengaged the sign panel and caused the sign panel to impact and indent the windshield. In System No. 2B, the rigid bracket and panel clips held the sign panel flush with the mast until the mast penetrated the windshield. The large rigid bracket on the end of the mast was responsible for the significant amount of windshield damage. The sign locking mechanism may be a contributor to failure of

portable sign supports, but it is also dependent on the sign panel material and the original design of the locking mechanism. Some mechanisms were designed to disengage the panel, and some were designed to keep the panel connected to the rest of the system, depending on which produced a safe performance for a particular portable sign support system.

The horizontal fiberglass crossbrace in System No. 3B released from the outer sleeve and then contacted the windshield. The roll-up bracket kept the sign panel intact with the mast, which may have led to more windshield damage, but the damage was insufficient to cause the system to fail the MASH criteria. System No. 3B also had rigid brackets attached to the mast, but these brackets did not contribute to the damage on the vehicle.

13 COMPUTER SIMULATION

13.1 Introduction

In addition to the full-scale crash tests, computer simulation was performed to evaluate the performance of one sign support system. Very little research has been done in the finite element analysis of work-zone sign support systems. Due to limitations in the small car finite element model, the simulation cannot be used to definitively predict failure but can be used to determine whether full-scale crash testing is necessary for a particular sign system. The glass material of the windshield has not been validated to accurately predict deformation or penetration, which are the two most common causes for failure of work-zone sign support systems. The simulation can be used to track the trajectory of the sign system as well as contact forces on the car in order to determine if the sign system would even impact the vehicle during a full scale crash test. Simulations of work-zone sign support systems could determine if full-scale crash tests are warranted, thus decreasing the development costs for manufacturers when designing a new system.

The portable sign support system from test no. WZ09-2A was impacted with a Geo Metro in a LS-DYNA simulation [35]. The Geo Metro V3 reduced-element model provided by the National Crash Analysis Center was used for the simulation effort. The Geo Metro is the finite element vehicle model which most closely represents the geometry of the 1100C Kia Rio test vehicle. Although the Geo Metro model weighed less than the Kia Rio, the weight is insignificant when impacting a light-weight sign system.

The validation of the simulation was accomplished in two stages. First, the material properties of the system parts were defined using only the Geo Metro bumper impacting the sign system. Then, the impact was simulated with a full car model and was validated again for test no.

WZ09-2A. The objective was to accurately predict the trajectory and failure of the sign system when compared to the actual full-scale crash test.

13.2 Sign Support System Model

Seventeen parts were used to model System No. WZ09-2A, as labeled in Figure 107. The flags and flag holder were determined to be insignificant in the test so they were excluded. Bolts and small connector plates were also excluded from the model, since the connections could be modeled accurately through LS-DYNA constraints.

The critical section to the safety performance of the sign stand was the base and fracture mechanism. System No. WZ09-2A was designed with eight holes in the lower mast at the top of the base tube, where fracture was intended to occur upon impact. A fine mesh was used for the springs and around the breakaway holes located in the lower mast and for the springs as shown in Figure 108. The lower and upper masts, the legs, and the sign panel were made from an unknown aluminum. The rigid brackets, base tube, top plate, springs, base plate, and base angle plates were made from an unknown steel. Since the material properties could not be achieved without tensile specimen tests, some estimates were made regarding the material properties. The stress-strain curve used for all steel parts was taken from *Project 2: Material Definition & Analysis* [36] and is shown in Figure 109. Since none of the steel parts tear or fracture, the failure criteria of the steel material was not as important as the failure criteria of the aluminum material.

Aluminum properties were initially taken from *Tension Test of Metals* [37]. The modulus of elasticity was 9,320 ksi (64.26 GPa), and the yield stress was 41.47 ksi (0.286 GPa). Since the lower mast was the critical section for fracture, the aluminum material properties needed to closely replicate those used in the full-scale crash test. The failure point at a stress of 42.77 ksi (0.295 GPa) and strain of 0.16 produced the closest results visually in the final simulation.

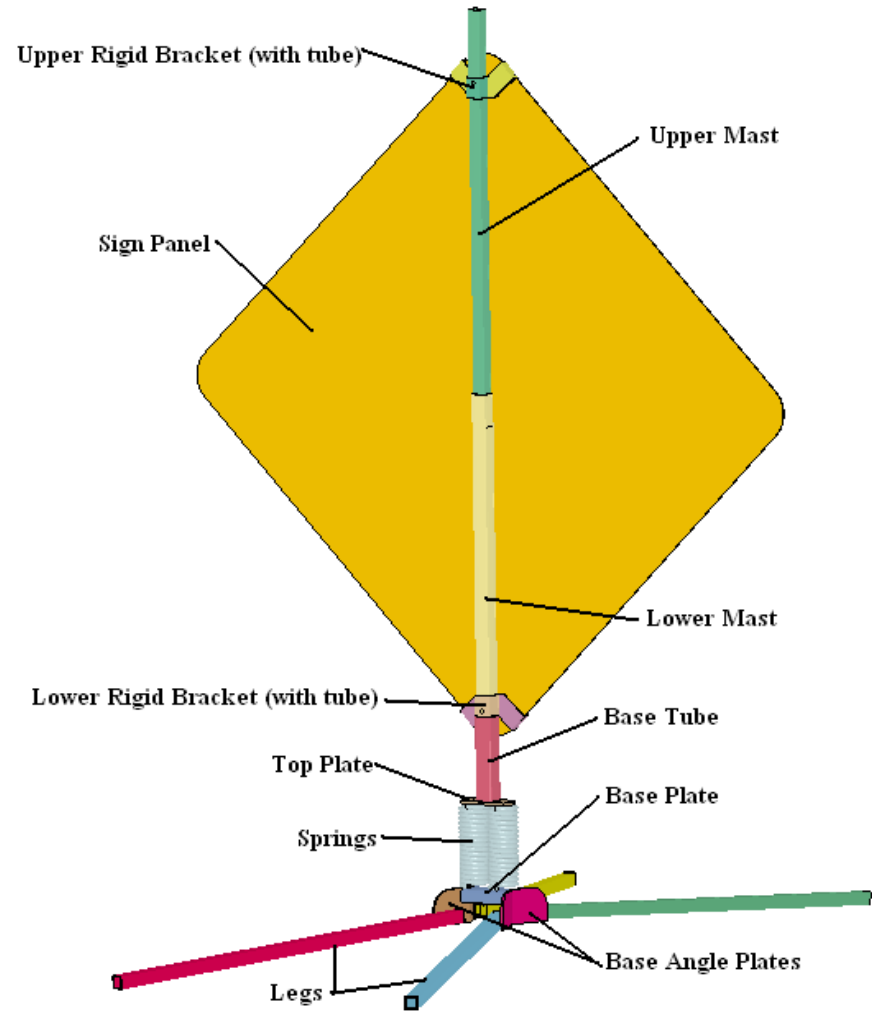

Figure 107. System No. WZ09-2A and the Finite Element Model

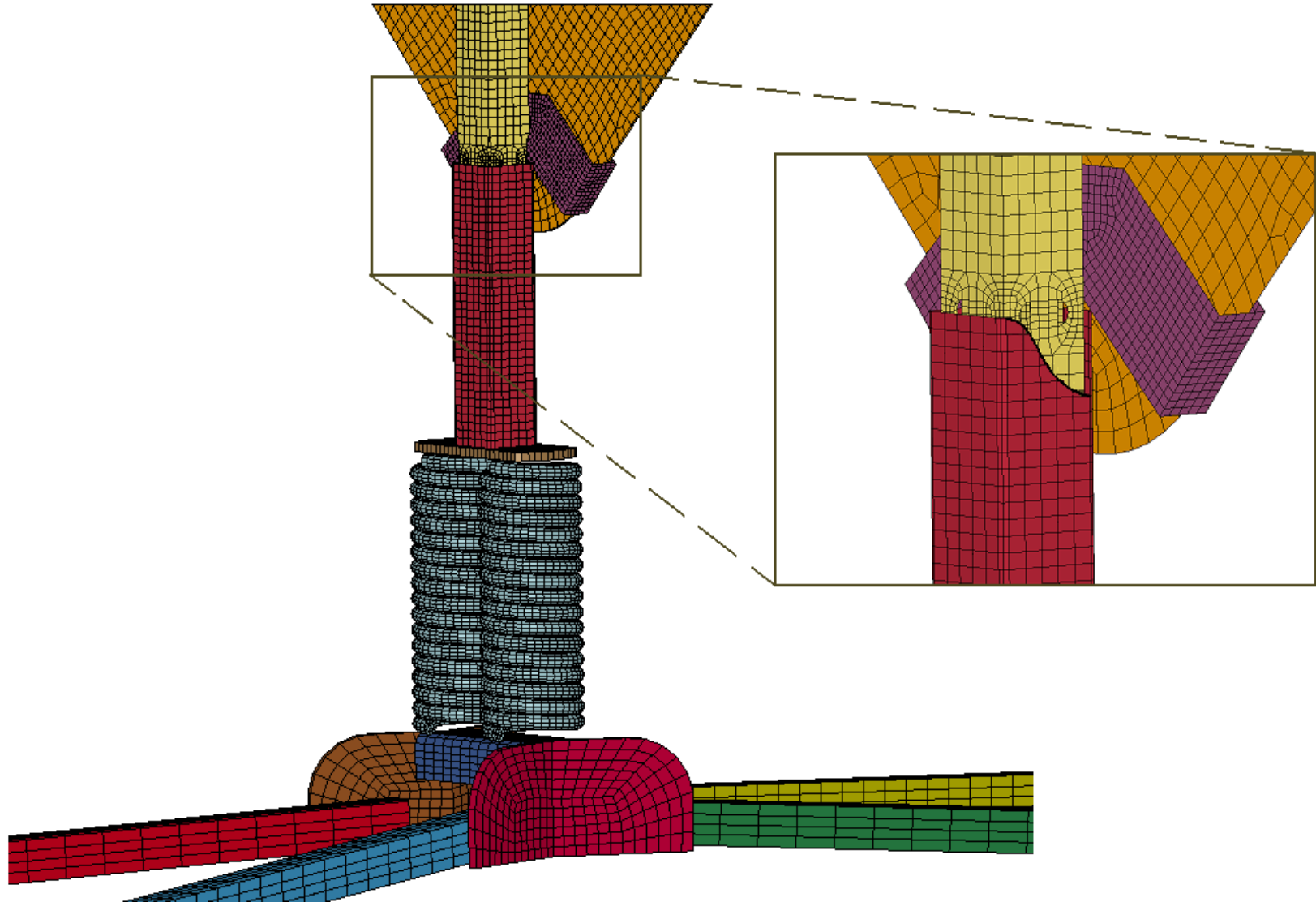

Figure 108. Mesh Detail at Base and Enlarged View of Breakaway Holes

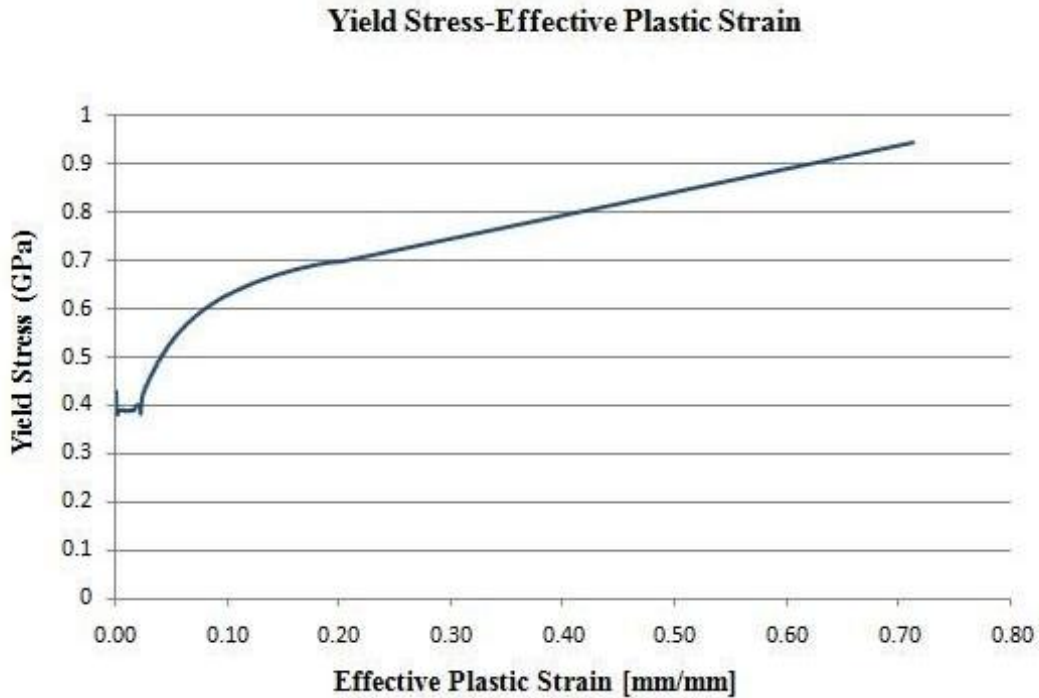

Figure 109. Steel Stress – Strain Curve

All parts were meshed as shell elements, except for the springs. The shell element formulation was Belytschko-Tsay [35]. The solid element formulation used for the solid springs was initially constant stress solid elements, but was later switched to fully-integrated, selectively-reduced elements to reduce the hourglass energy in the model. A summary of each part is shown in Table 26.

Rivets were used to constrain the top and bottom of the springs to the top plate and bent plate. In reality, washers fit securely inside the springs and are bolted through the top plate and bent plate. These washers were not modeled to simplify the connections, but *CONSTRAINED_RIVET holds a constant distance between the springs, top plate, and base plate and allows for rotation, which has the same performance of the washers. Rivets were also used to constrain the legs and base angle plates, which allowed the legs to rotate similar to the pin used in the actual system.

Table 26. Summary of Sign System Parts

Part	Weight [lb]	Material	Element Formulation
Leg1	1.76	Aluminum Tube	Belytschko-Tsay shell
Leg2	1.76	Aluminum Tube	Belytschko-Tsay shell
Leg3	1.76	Aluminum Tube	Belytschko-Tsay shell
Leg4	1.76	Aluminum Tube	Belytschko-Tsay shell
AnglePlate1	1.75	Steel	Belytschko-Tsay shell
AnglePlate2	1.75	Steel	Belytschko-Tsay shell
Bent Plate	0.99	Steel	Belytschko-Tsay shell
Upper Mast	1.68	Aluminum Tube	Belytschko-Tsay shell
Lower Mast	2.21	Aluminum Tube	Belytschko-Tsay shell
Top Plate	0.87	Steel	Belytschko-Tsay shell
Base Tube	1.60	Steel	Belytschko-Tsay shell
Springs	11.76	Steel	fully integrated S/R solid
Upper Bracket Tube	0.21	Steel	Belytschko-Tsay shell
Upper Bracket	0.80	Steel	Belytschko-Tsay shell
Lower Bracket Tube	0.25	Steel	Belytschko-Tsay shell
Lower Bracket	0.80	Steel	Belytschko-Tsay shell
Sign Panel	17.92	Aluminum Sheet	Belytschko-Tsay shell

Spot welds were used to constrain all other parts in the sign system. The connections between the base angle plates and base plate, the upper mast and lower mast, the lower mast and top plate, and the base tube and the top plate were all defined without failure. No failure was defined since these connections did not move during test no. WZ09-2A. Other connections that failed during the crash test were assigned failure criteria to visually match the results of the test. The *CONSTRAINED_SPOTWELD between the lower rigid bracket tube and the lower mast had a 450 lb (2 kN) normal force at failure and a 225 lb (1 kN) shear force at failure. The *CONSTRAINED_SPOTWELD between the upper rigid bracket tube and the upper mast had a 2,248 lb (10 kN) normal force at failure and a 1,124 lb (5 kN) shear force at failure. The upper bracket did not fail during the full-scale test, so the force to break the welds was higher. The

spotwelds between the upper rigid bracket and upper rigid bracket tubes had a 1,349 lb (6 kN) normal force at failure and a 674 lb (3 kN) shear force at failure. The spotwelds between the lower rigid bracket and lower rigid bracket tube had a 450 lb (2 kN) normal force at failure and a 225 lb (1 kN) shear force at failure.

13.3 Initial Simulation

A steel bumper taken from the Geo Metro model was given a point mass of 1,764 lb (800 kg) to simulate the entire mass of the 1,808 lb (820 kg) vehicle. The bumper was used in place of the full car model to save computational time in refining the material properties. The bumper was placed in the model at the approximate height of the Geo Metro bumper and given an initial velocity of 60 mph (26.83 mm/ms). The *CONTACT_AUTOMATIC_SINGLE_SURFACE was used as the contact between all sign system parts and the bumper.

13.3.1 Results

Initially, the lower mast did not fracture cleanly because some elements stretched a long distance before all of the nodes failed. The failure criteria for the aluminum material was at a stress of 43.5 ksi (0.30 GPa) and a strain of 0.13. Refining the mesh around the breakaway holes in the lower mast caused the fracture to occur along a smooth surface. The failure point on the aluminum stress-strain curve was then modified to get the lower mast to fracture at the same time as the full-scale crash test.

13.4 Full-Scale Simulation

After the mast fracture was simulated accurately with the bumper impacting the sign stand, the full Geo Metro model replaced the bumper. The Geo Metro impacted the centerline of the sign system at 60 mph (26.83 mm/ms) and at a 0 degree orientation. Once again, *CONTACT_AUTOMATIC_SINGLE_SURFACE was used for the contact definition.

Hourglass control was applied to all of the shell parts in the sign system because visible hourglassing occurred.

13.4.1 Model Validation

The three ways to validate the simulation are velocity comparisons, the failure mechanism, and the visual trajectory and dynamics of the parts. Velocity from the full-scale test was measured from the high-speed test video using video analysis software. The velocity is somewhat subjective due to the resolution of the video and the small displacements over each time frame.

The ridedown acceleration of the car was small due to the low mass of the sign stand compared to the vehicle. Even though an accelerometer was used during test no WZ09-2A, the acceleration traces could not be compared to the simulation. Due to the small change in velocity, noise occurs in the acceleration plots, which makes the acceleration traces unrealistic even when filtered.

13.4.2 Results

A comparison between the simulation and the full-scale test video is shown in Figures 110 and 111. The lower mast fractured at the breakaway holes, which was critical for the trajectory of the sign system to be accurate. The fracture appears accurate when compared to the full-scale crash test, except the lower mast in the full-scale crash test lags the simulation by 3 ms. The trajectories of all parts appear similar for the first 40 ms. Around 50 ms, the sign panel in the simulation began to slip out of the upper rigid bracket therefore the sign panel does not bend as much as was observed in the full-scale crash test. At this same time, the bottom of the mast began to rotate slower than observed in test no. WZ09-2A.

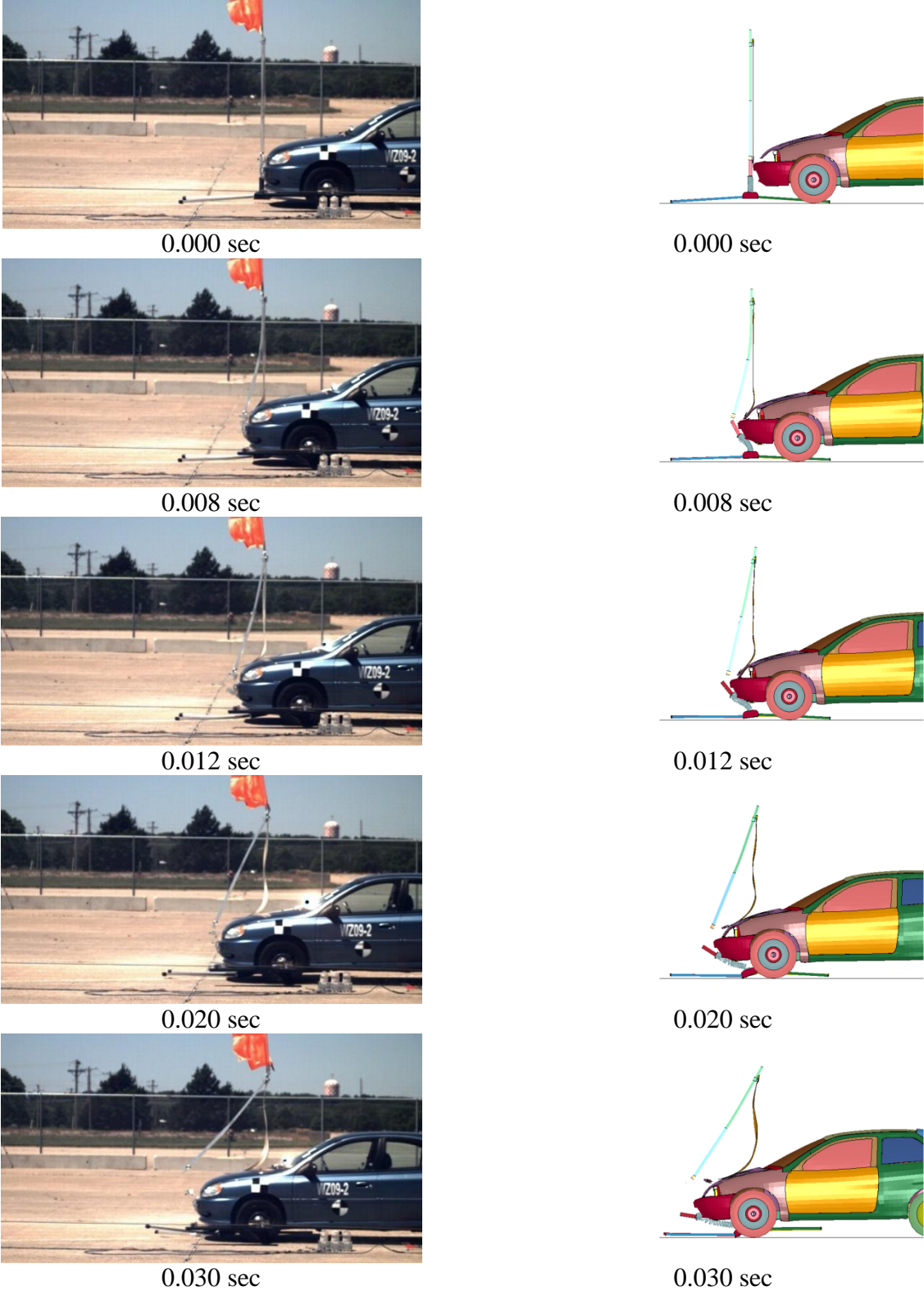

Figure 110. Comparison of Full-Scale Crash Test and Simulation Results

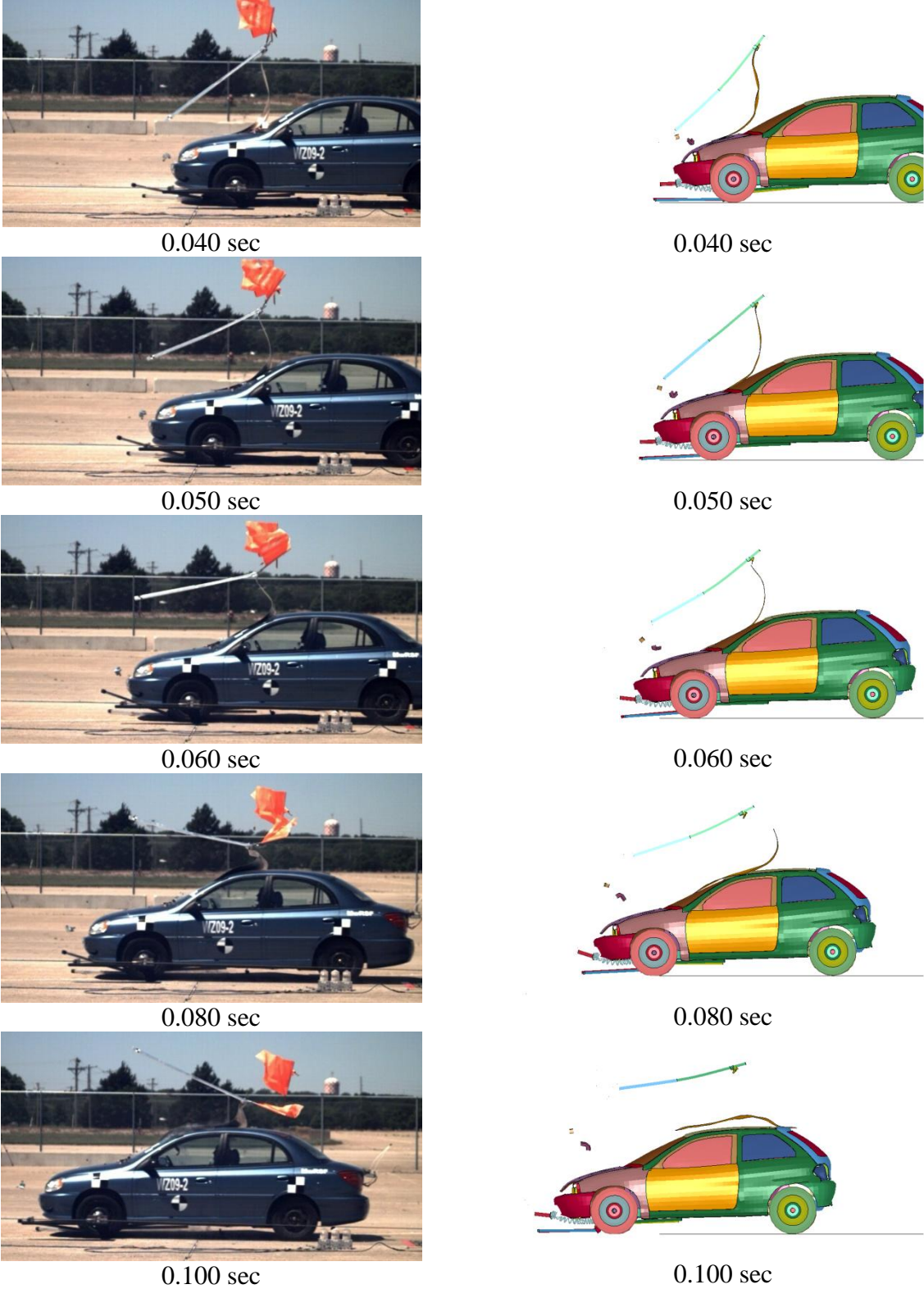

Figure 111. Comparison of Full-Scale Crash Test and Simulation Result

A target was placed above the fracture point on the lower mast in test no. WZ09-2A. The velocity of the target was compared to the velocity at an equivalent point on the mast in the simulation and is shown in Figure 112. The full-scale crash test and the simulation achieved the same peak values, and the curves were nearly identical except for a phase shift. The curves oscillate because the mast vibrates through the air after the impact event.

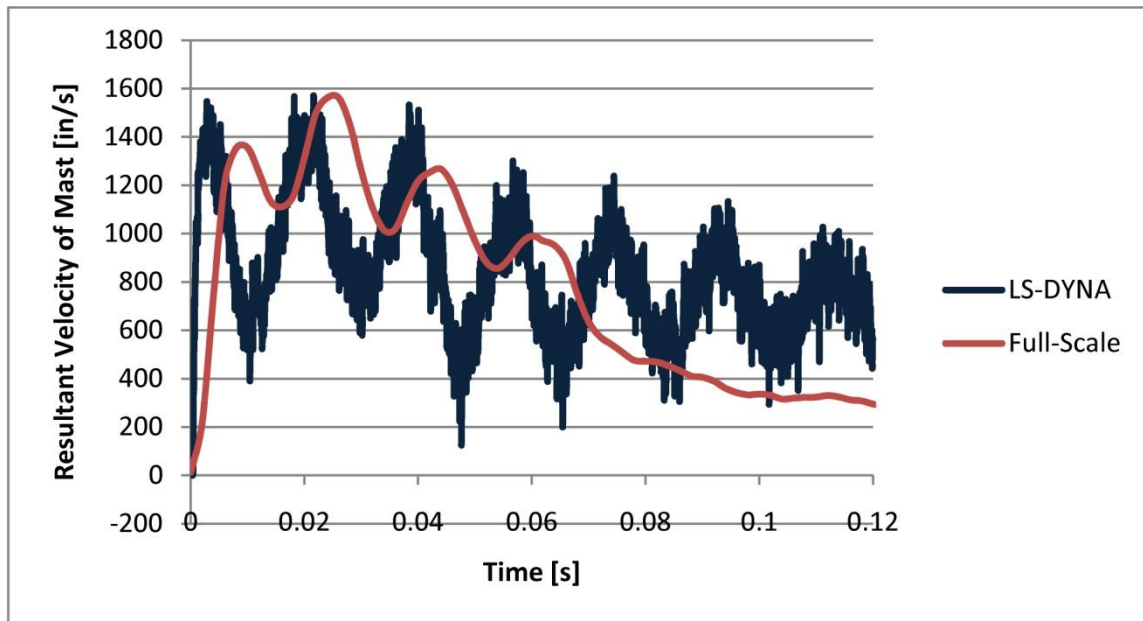

Figure 112. Velocity of Mast vs. Time

Since the mass of the sign stand is small and the actual accelerations are low, the force exerted on the sign stand should also be low. The contact force was filtered with Butterworth (BW) at 100 Hz. The contact force between the sign panel and windshield is shown in Figure 113. A maximum force of 654 lb (2.91 kN) occurred at the initial impact. There is no validation data to compare if this force is accurate, but it seems slightly high to cause 2¼ in. (57 mm) of windshield deformation.

The internal energy is very small compared to the total energy, as shown in Figure 114. The total energy was found to be 229,000 ft-lbf (310,000 J), which is very close to the predicted value of 218,000 ft-lbf (295,000 J). The velocity change was small, as shown in Figure 115, so

very little of the kinetic energy was converted to internal energy. The velocity change in test no. WZ09-2A was 2.2 mph (1.0 mm/ms), which is approximately the same observed in the simulation which was 1.1 mph (0.5 mm/ms).

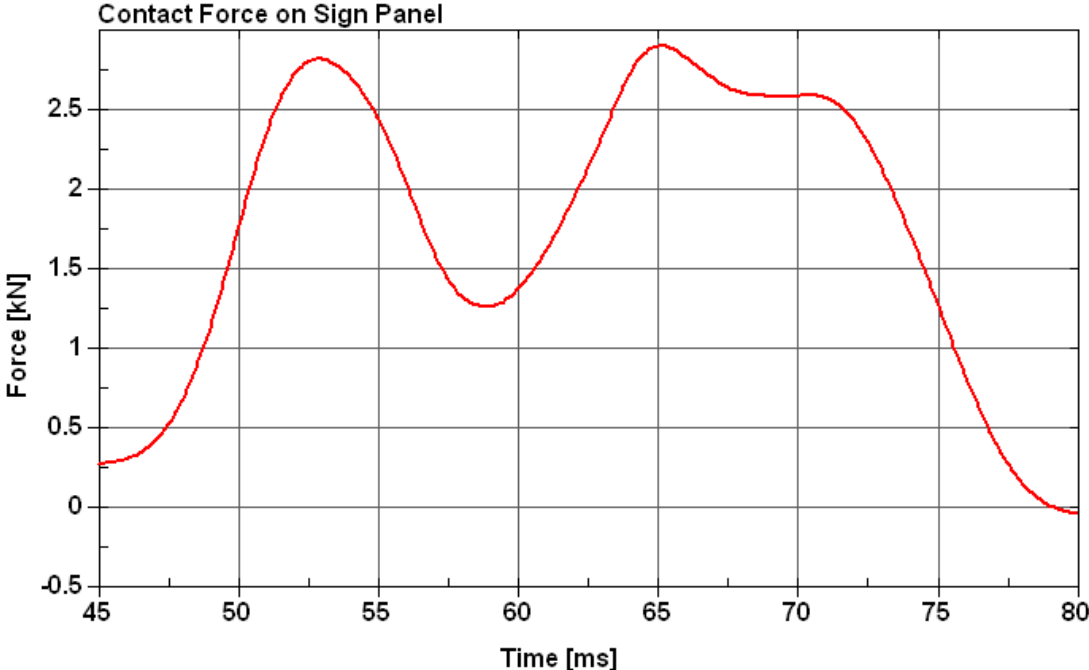

Figure 113. Contact Force between Sign Panel and Windshield

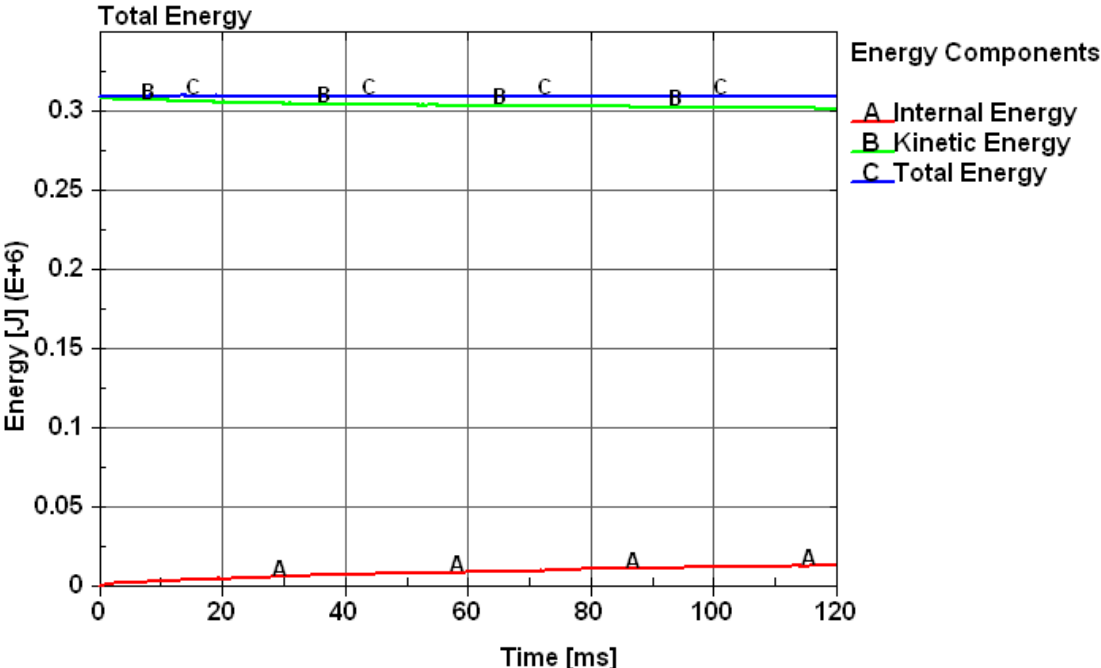

Figure 114. Energy vs. Time

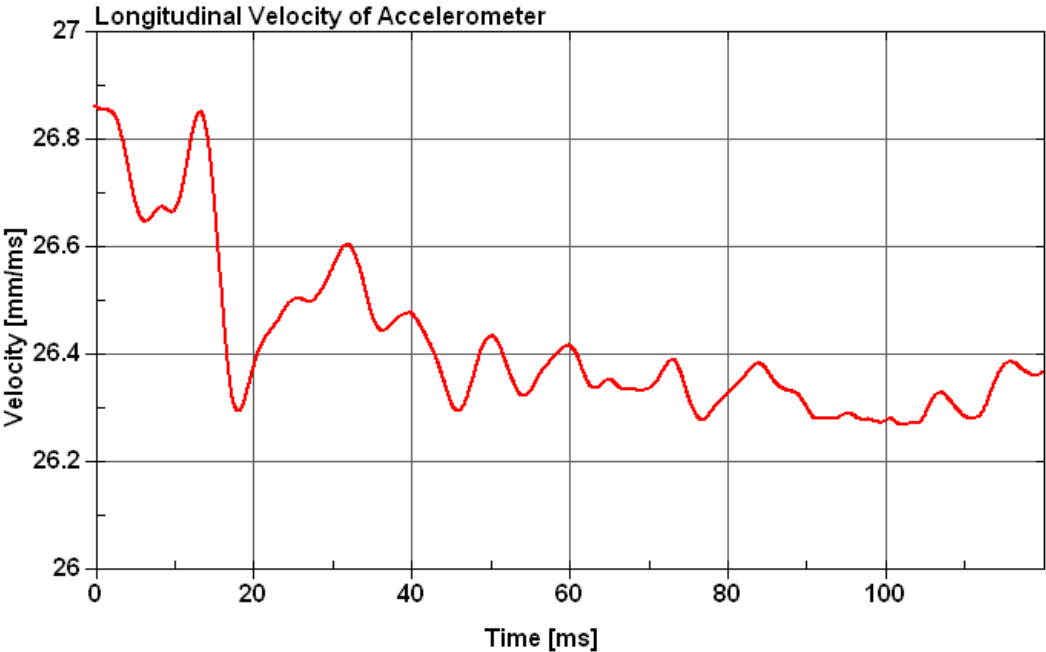

Figure 115. Longitudinal Velocity vs. Time

Excessive hourglassing was initially a problem in the simulation. The *HOURLASS control was applied to all of the shell elements in the sign system. The springs were changed

from the default constant-stress element formulation to fully-integrated selectively-reduced element formulation to remove all hourglass energy in the springs. Many shell and solid element parts in the Geo Metro model were also changed to fully-integrated elements. The hourglass energy was negligible compared to the internal energy, as shown in Figure 116, which was an acceptable level in a simulation.

Although the windshield material model was believed to be inaccurate in predicting deformations, the windshield deformed similar to what was found in test no. WZ09-2A. A comparison of the deformation in the simulation is shown in Figure 117. The vertical displacement of the windshield was compared over time, as shown in Figure 118. The maximum vertical deformation in the simulation was 2.24 in. (56.8 mm). The maximum windshield deformation in the full scale crash test was 2¼ in. (57 mm).

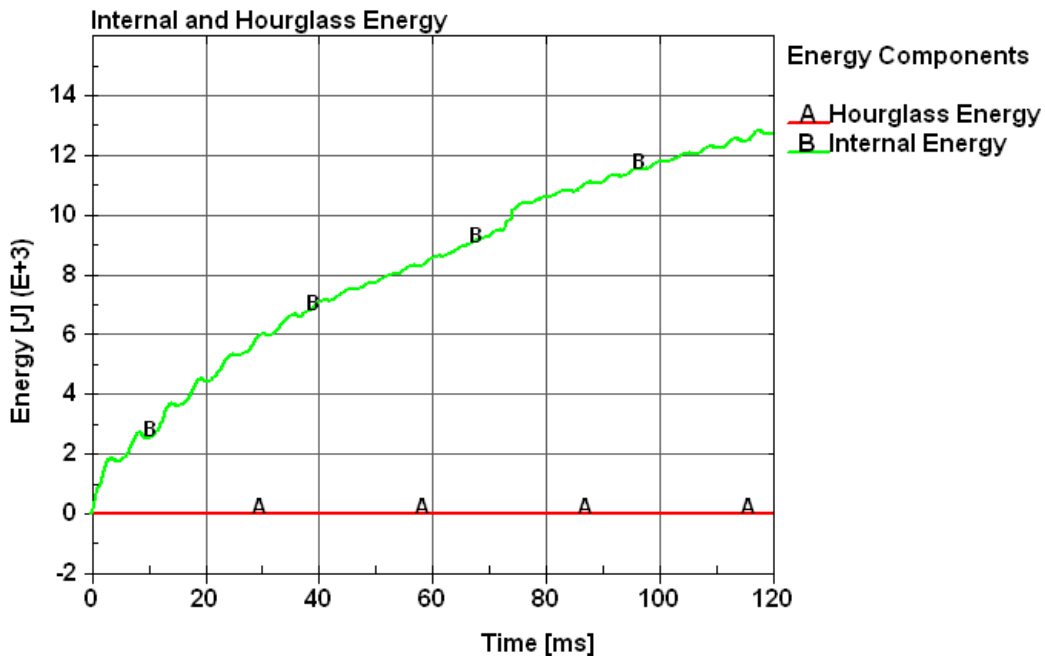

Figure 116. Internal Energy and Hourglass Energy vs. Time

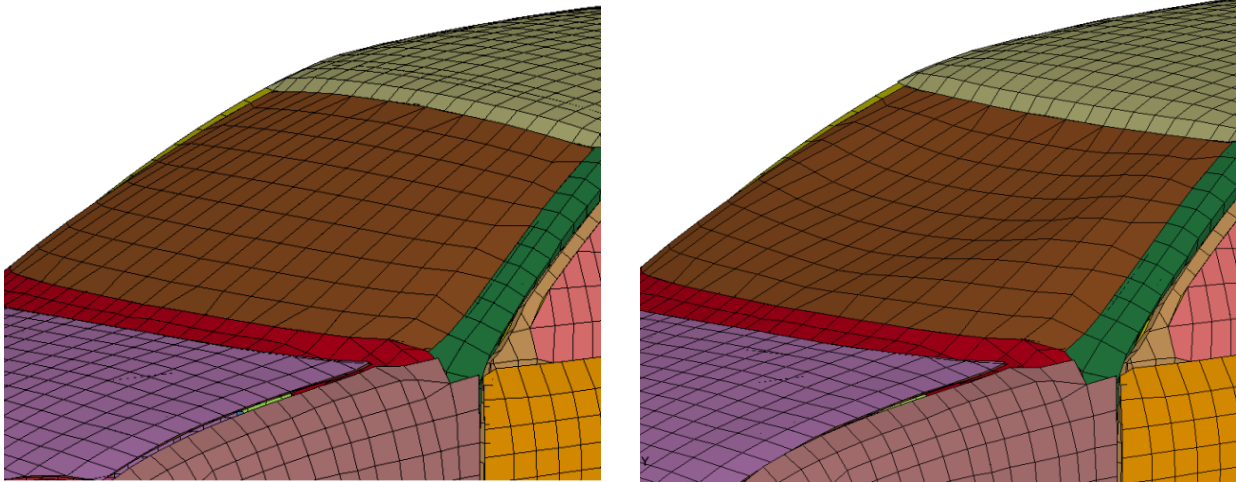

Figure 117. Windshield Deformation

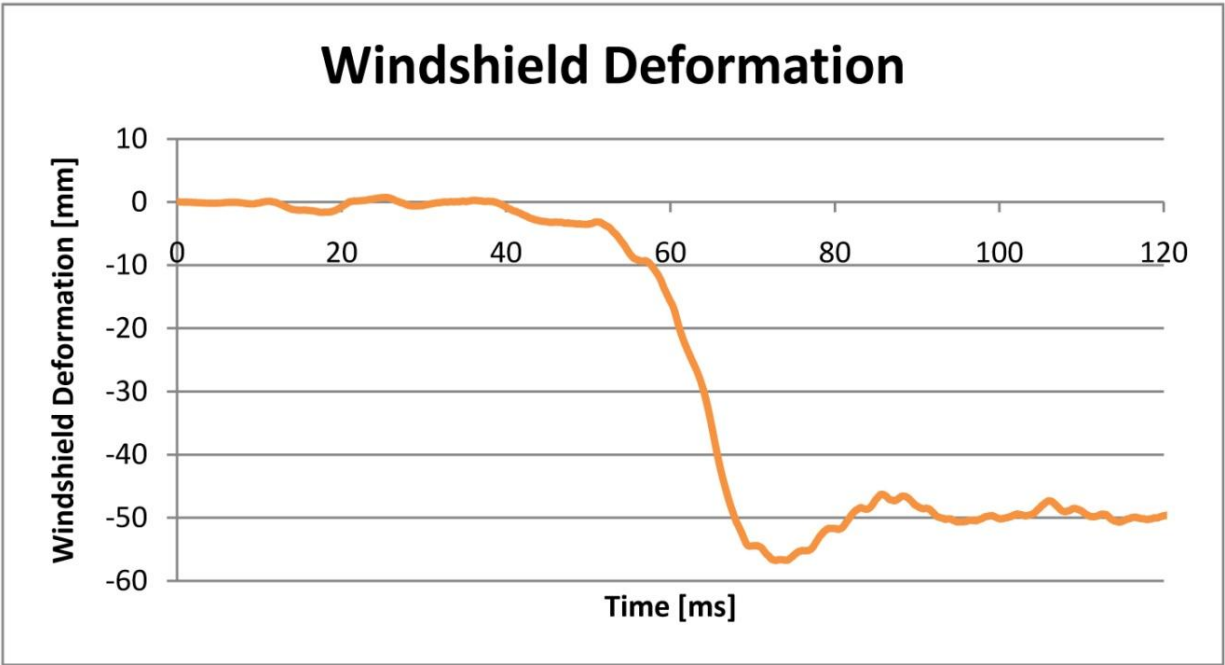

Figure 118. Windshield Deformation vs. Time

13.5 Conclusions

System No. WZ09-2A was impacted with a Geo Metro in an LS-DYNA simulation. Once the sign system model was created and meshed, basic material properties were defined for all parts. The sign system was first impacted with a bumper with an equivalent mass of the Geo Metro to save computational time. Aluminum material properties were refined until the lower

mast fractured at the breakaway holes and at the correct time. The full Geo Metro model was then implemented in the simulation.

The velocity of the mast arm compared very favorably to the results obtained from the full-scale crash test. The test lagged the simulation, but if the simulation velocity curve was shifted 3 ms (the time that the test mast fracture lags) the peaks would be very close. The kinetic energy of both simulations was very close to the predicted energy of 218,000 ft-lbf (295,000 J). The internal energy was small compared to the total energy, which was predicted since the velocity change was so small after the impact event.

The dynamics and trajectory of the sign system closely matched that observed in the full-scale crash test for the first 50 ms of the simulation. The trajectory of the mast after this time was not important because the simulation had already shown that the sign panel would contact the entire windshield. The fracture of the mast was the critical event in the simulation, and it was achieved accurately, even though it occurred 3 ms earlier than in test no. WZ09-2A.

The simulation showed that a full-scale crash test was warranted for this particular work-zone sign support system. Even though finite element modeling cannot be used to predict the success or failure of work-zone traffic control devices with the MASH evaluation criteria, it can be used to determine where and how the device will impact a vehicle. Modeling sign systems has its limitations because it is hard to know how the system and connections will perform upon impact without a full-scale crash test. Future finite element modeling with work-zone sign support systems can be used during the design phase of new systems. Simulations can be used to predict whether the system will impact the vehicle significantly. If so, the system could be redesigned in the model until minimal vehicle contact occurred—a good indicator that the system will perform acceptably with the MASH criteria. Simulation cannot be used as a

replacement to full-scale crash testing, but could save on the cost of testing with a poor performing system. Work-zone traffic control device simulations could also be very beneficial when trying to design and manufacture new sign systems in the future.

14 SUMMARY, CONCLUSIONS, AND RECOMMENDATIONS

An analytical study was conducted to evaluate the safety performance of work-zone, portable sign support systems accepted under NCHRP Report No. 350 to determine whether these systems are likely to meet the MASH safety performance criteria. The sign support system parameters that were predicted to be most important for resulting in system failure under MASH with either test vehicle included mast stages, mast material, sign panel material, height to top of mast, flag staff material, and orientation. These system parameters, along with other important parameters for each vehicle, were analyzed in combination with one another in order to select portable sign support systems with a high propensity for failure. The accuracy of this method for predicting MASH performance was evaluated through full-scale crash testing of systems with a high propensity for failure, followed by a comparison of the test results to the predicted performance. A total of eight crash tests were conducted on various portable sign support systems. A summary of the safety performance evaluations is provided in Tables 27 through 30.

Three of the work-zone traffic control devices satisfactorily met the safety performance evaluation criteria for one of the two required TL-3 crash tests set forth in MASH. These devices include:

(System No. 2A – Test Designation No. 3-71) A double-upright coil, spring-mounted, sign support with a 48-in. x 48-in. (1,219-mm x 1,219-mm) diamond-shaped aluminum sign panel mounted at a height of 20 $\frac{1}{8}$ in. (511 mm) from the ground to the bottom of the sign panel and with three wood-staffed flags mounted at a height of 88 $\frac{1}{2}$ in. (2,248 mm) from the ground to the top of the mast.

(System No. 3B – Test Designation No. 3-71) A dual-extension, spring-mounted, sign support with a 48-in. x 48-in. (1,219-mm x 1,219-mm) diamond-shaped vinyl roll-up sign panel mounted at a height of 21 in. (533 mm) from the ground to the bottom of the sign panel and with two wood-staffed flags mounted at a height of 90 $\frac{1}{2}$ in. (2,299 mm) from the ground to the top of the mast.

Table 27. Summary of Safety Performance Evaluation Results, Test No. WZ09-1

Evaluation Factors	Evaluation Criteria	Test No. WZ09-1A	Test No. WZ09-1B	
Structural Adequacy	B. The test article should readily activate in a predictable manner by breaking away, fracturing, or yielding.	S	S	
Occupant Risk	D. Detached elements, fragments or other debris from the test article should not penetrate or show potential for penetrating the occupant compartment, or present undue hazard to other traffic, pedestrians, or personnel in a work zone. Deformations of, or intrusions into, the occupant compartment should not exceed limits set forth in Section 5.3 and Appendix E.	U	U	
	E. Detached elements, fragments or other debris from the test article, or vehicular damage should not block the driver's vision or otherwise cause the driver to lose control of the vehicle.	U	U	
	F. The vehicle should remain upright during and after collision. The maximum roll and pitch angles are not to exceed 75 degrees.	S	S	
	H. Occupant Impact Velocities (OIV) (see Appendix A, Section A5.3 for calculation procedure) should satisfy the following limits:	S	S	
	Occupant Impact Velocity Limits			
	Component			Preferred
	Longitudinal	10 ft/s (3.0 m/s)	16 ft/s (4.9 m/s)	
I. The Occupant Ridedown Acceleration (see Appendix A, Section A5.3 for calculation procedure) should satisfy the following limits:	S	S		
Occupant Ridedown Acceleration Limits				
Component			Preferred	Maximum
Longitudinal and Lateral	15.0 g's	20.49 g's		
Vehicle Trajectory	N. Vehicle trajectory behind the test article is acceptable.	S	S	
Method of Failure ¹		1,2,3,4,5	1,2,3,4	

S - Satisfactory U - Unsatisfactory NA - Not Applicable

¹Method of Failure

- | | |
|---|--|
| 1 - Severe windshield cracking and fracture | 4 - Windshield penetration |
| 2 - Windshield indentation | 5 - Other occupant compartment penetration |
| 3 - Obstruction of Driver Visibility | 6 - Roof deformation |

Table 28. Summary of Safety Performance Evaluation Results, Test No. WZ09-2

Evaluation Factors	Evaluation Criteria	Test No. WZ09-2A	Test No. WZ09-2B	
Structural Adequacy	B. The test article should readily activate in a predictable manner by breaking away, fracturing, or yielding.	S	S	
Occupant Risk	D. Detached elements, fragments or other debris from the test article should not penetrate or show potential for penetrating the occupant compartment, or present undue hazard to other traffic, pedestrians, or personnel in a work zone. Deformations of, or intrusions into, the occupant compartment should not exceed limits set forth in Section 5.3 and Appendix E.	S	U	
	E. Detached elements, fragments or other debris from the test article, or vehicular damage should not block the driver's vision or otherwise cause the driver to lose control of the vehicle.	S	U	
	F. The vehicle should remain upright during and after collision. The maximum roll and pitch angles are not to exceed 75 degrees.	S	S	
	H. Occupant Impact Velocities (OIV) (see Appendix A, Section A5.3 for calculation procedure) should satisfy the following limits:	S	S	
	Occupant Impact Velocity Limits			
	Component			Preferred
Longitudinal	10 ft/s (3.0 m/s)	16 ft/s (4.9 m/s)		
I. The Occupant Ridedown Acceleration (see Appendix A, Section A5.3 for calculation procedure) should satisfy the following limits:	S	S		
Occupant Ridedown Acceleration Limits				
Component			Preferred	Maximum
Longitudinal and Lateral	15.0 g's	20.49 g's		
Vehicle Trajectory	N. Vehicle trajectory behind the test article is acceptable.	S	S	
Method of Failure ¹		NA	1,2,3,4	

S - Satisfactory U - Unsatisfactory NA - Not Applicable

¹Method of Failure

- | | |
|---|--|
| 1 - Severe windshield cracking and fracture | 4 - Windshield penetration |
| 2 - Windshield indentation | 5 - Other occupant compartment penetration |
| 3 - Obstruction of Driver Visibility | 6 - Roof deformation |

Table 29. Summary of Safety Performance Evaluation Results, Test No.WZ09-3

Evaluation Factors	Evaluation Criteria	Test No. WZ09-3A	Test No. WZ09-3B	
Structural Adequacy	B. The test article should readily activate in a predictable manner by breaking away, fracturing, or yielding.	S	S	
Occupant Risk	D. Detached elements, fragments or other debris from the test article should not penetrate or show potential for penetrating the occupant compartment, or present undue hazard to other traffic, pedestrians, or personnel in a work zone. Deformations of, or intrusions into, the occupant compartment should not exceed limits set forth in Section 5.3 and Appendix E.	U	S	
	E. Detached elements, fragments or other debris from the test article, or vehicular damage should not block the driver's vision or otherwise cause the driver to lose control of the vehicle.	U	S	
	F. The vehicle should remain upright during and after collision. The maximum roll and pitch angles are not to exceed 75 degrees.	S	S	
	H. Occupant Impact Velocities (OIV) (see Appendix A, Section A5.3 for calculation procedure) should satisfy the following limits:	S	S	
	Occupant Impact Velocity Limits			
	Component			Preferred
Longitudinal	10 ft/s (3.0 m/s)	16 ft/s (4.9 m/s)		
I. The Occupant Ridedown Acceleration (see Appendix A, Section A5.3 for calculation procedure) should satisfy the following limits:	S	S		
Occupant Ridedown Acceleration Limits				
Component			Preferred	Maximum
Longitudinal and Lateral	15.0 g's	20.49 g's		
Vehicle Trajectory	N. Vehicle trajectory behind the test article is acceptable.	S	S	
Method of Failure ¹		1,2,3	NA	

S - Satisfactory U - Unsatisfactory NA - Not Applicable

¹Method of Failure

- | | |
|---|--|
| 1 - Severe windshield cracking and fracture | 4 - Windshield penetration |
| 2 - Windshield indentation | 5 - Other occupant compartment penetration |
| 3 - Obstruction of Driver Visibility | 6 - Roof deformation |

Table 30. Summary of Safety Performance Evaluation Results, Test No. WZ09-4

Evaluation Factors	Evaluation Criteria	Test No. WZ09-4A	Test No. WZ09-4B	
Structural Adequacy	B. The test article should readily activate in a predictable manner by breaking away, fracturing, or yielding.	S	S	
Occupant Risk	D. Detached elements, fragments or other debris from the test article should not penetrate or show potential for penetrating the occupant compartment, or present undue hazard to other traffic, pedestrians, or personnel in a work zone. Deformations of, or intrusions into, the occupant compartment should not exceed limits set forth in Section 5.3 and Appendix E.	U	S	
	E. Detached elements, fragments or other debris from the test article, or vehicular damage should not block the driver's vision or otherwise cause the driver to lose control of the vehicle.	S	S	
	F. The vehicle should remain upright during and after collision. The maximum roll and pitch angles are not to exceed 75 degrees.	S	S	
	H. Occupant Impact Velocities (OIV) (see Appendix A, Section A5.3 for calculation procedure) should satisfy the following limits:	S	S	
	Occupant Impact Velocity Limits, ft/s (m/s)			
	Component			Preferred
Longitudinal	10 ft/s (3.0 m/s)	16 ft/s (4.9 m/s)		
I. The Occupant Ridedown Acceleration (see Appendix A, Section A5.3 of MASH for calculation procedure) should satisfy the following limits:	S	S		
Occupant Ridedown Acceleration Limits (g's)				
Component			Preferred	Maximum
Longitudinal and Lateral	15.0 g's	20.49 g's		
Vehicle Trajectory	N. Vehicle trajectory behind the test article is acceptable.	S	S	
Method of Failure ¹		4,5	NA	

S - Satisfactory U - Unsatisfactory NA - Not Applicable

¹Method of Failure

- | | |
|---|--|
| 1 - Severe windshield cracking and fracture | 4 - Windshield penetration |
| 2 - Windshield indentation | 5 - Other occupant compartment penetration |
| 3 - Obstruction of Driver Visibility | 6 - Roof deformation |

(System No. 4B – Test Designation No. 3-72) A double-upright coil, spring-mounted, sign support with a 48-in. x 48-in. (1,219-mm x 1,219-mm) diamond-shaped aluminum sign panel mounted at a height of $14^{15}/_{16}$ in. (379 mm) from the ground to the bottom of the sign panel and with three wood-staffed flags mounted at a height of $100^{11}/_{16}$ in. (2,557 mm) from the ground to the top of the mast.

Five work-zone traffic control devices performed unsatisfactorily according to the MASH evaluation criteria even though prior acceptable performance was obtained according to NCHRP Report No. 350. These devices include:

(System No. 1A – Test Designation No. 3-72) A double-upright coil, spring-mounted, sign support with a 48-in. x 48-in. (1,219-mm x 1,219-mm) diamond-shaped aluminum sign panel mounted at a height of $59^{15}/_{16}$ in. (1,522 mm) from the ground to the bottom of the sign panel and with three wood-staffed flags mounted at a height of $135^5/_{16}$ in. (3,437 mm) from the ground to the top of the mast.

(System No. 1B – Test Designation No. 3-72) A $25^7/_{16}$ -in. wide x 72-in. deep x $109^7/_{8}$ -in. tall (646-mm x 1,829-mm x 2,791-mm) parallel dual upright sign support with a 48-in. x 48-in. (1,219-mm x 1,219-mm) diamond-shaped aluminum sign panel mounted at a height of $61^3/_{8}$ in. (1,565 mm) from the ground to the bottom of the sign panel and with one warning light mounted at a height of $109^7/_{8}$ in. (2,791 mm).

(System No. 2B – Test Designation No. 3-71) A tripod-mounted, portable sign support with a 48-in. x 48-in. (1,219-mm x 1,219-mm) diamond-shaped aluminum sign panel mounted at a height of $14^{11}/_{16}$ in. (373 mm) from the ground to the bottom of the sign panel and with two wood-staffed flags mounted at a height of 72 in. (1,829 mm) from the ground to the top of the sign panel.

(System No. 3A – Test Designation No. 3-71) A double-upright coil, spring-mounted, sign support with a 48-in. x 48-in. (1,219-mm x 1,219-mm) diamond-shaped aluminum sign panel mounted at a height of 18 in. (457 mm) from the ground to the bottom of the sign panel and with three wood-staffed flags mounted at a height of 89 in. (2,261 mm) from the ground to the top of the mast.

(System No. 4A – Test Designation No. 3-72) A double-upright coil, spring-mounted, sign support with a 48-in. x 48-in. (1,219-mm x 1,219-mm) diamond-shaped vinyl roll-up sign panel mounted at a height of $13^3/_{8}$ in. (340 mm) from the ground to the bottom of the sign panel and with three wood-staffed flags mounted at a height of $92^5/_{16}$ in. (2,345 mm) from the ground to the top of the mast.

For portable sign support systems, their safety performance is based on the behavior of many sign parameters such as the stiffness and strength of the mast and stand, height of sign panel and mast, sign panel material, and flag and light attachments. Consequently, slight

differences in system details can potentially lead to very different results. Extreme care should be taken when attempting to categorize similar products for various manufacturers. Full-scale crash testing is the only way to verify the safety performance of a particular device.

The research conducted herein was not comprehensive of all work-zone traffic control devices and therefore cannot be used to predict acceptance or failure of a particular work-zone traffic control device. The methodology utilized for categorizing and sorting the work-zone systems was specifically tailored to select a specific sub-set of systems and for use in the testing for this project. There are other existing work-zone systems that were not analyzed in this study that would also be critical for failure under the MASH evaluation criteria.

For the pickup truck, all four systems that were full-scale crash-tested were predicted to have a critical failure with the MASH evaluation criteria, and three of the four systems failed with significant windshield penetration. For the small car, System No. 2A, which was predicted to fail with the MASH evaluation criteria, had a successful evaluation with 2¼ in. (57 mm) of windshield indentation. System No. 2B with the small car was recommended to be re-tested with the MASH evaluation criteria and failed with significant windshield penetration. System No. 3A was predicted to fail MASH and did fail due to excessive windshield deformation. System No. 3B was also predicted to fail but passed with 2¼ in. (57 mm) of windshield deformation.

Since all of the portable sign support systems had previously passed the TL-3 small car criteria defined in NCHRP Report No. 350, it was expected that many systems tested with the MASH small car would also perform satisfactorily. While this result may have been true for System Nos. 3B, both System Nos. 2B and 3A failed the MASH small car test. Most current crashworthy sign systems should perform satisfactorily with the MASH small car. However, it is recommended that those systems with a marginal pass or those systems exhibiting any of the

important parameters shown in Table 31 for the small car should be re-tested with MASH test designation no. 3-71 to verify safety performance. The sign locking mechanism, and specifically rigid brackets, needs to be analyzed to determine if the sign panel will or will not disengage upon impact, which would help predict its safety performance.

Since no work-zone, portable sign support systems have been full-scale crash tested with a pickup truck prior to this study, it is recommended that those systems which are similar to those tested herein or designs exhibiting any of the important parameters shown in Table 31 for the pickup truck be tested with MASH test designation no. 3-72 to verify their safety performance. Other sign panel materials besides aluminum need to be evaluated in combinations with other parameters to determine what is important for a specific system. Rigid sign materials should be crash tested in the condition used in the field with reflective sheeting. Individual portable sign support systems need to be analyzed based on the most critical attachments and orientations.

Table 31. Parameters Deemed Critical for Potential System Failure

Parameter	Pickup Truck	Small Car
Sign Panel Material	Aluminum	Aluminum
Height to Top of Mast	75-135 in.	59-110 in.
Presence of Flags	Without Flags	With and Without Flags
Orientation	Both 0 and 90 degrees	Both 0 and 90 degrees
Sign Locking Mechanism	NA	Rigid Brackets
Base Layout	X-footprint	NA

The breakaway mechanism (or lack thereof) is a key component of portable sign support systems that affect where and how the mast or sign panel will strike the vehicle. This feature was not considered as an independent parameter within this study because not all breakaway sign systems function as they were intended to, and some sign systems not specifically classified as

breakaway do break away upon impact. Therefore, it was difficult to classify portable sign support systems as breakaway or non-breakaway since they may not perform as originally intended. In general, the breakaway mechanism (or lack thereof) needs to be analyzed on individual systems in conjunction with other system parameters in order to determine if it is beneficial or detrimental to the safety performance of the system.

Manufacturers can use the analysis and crash testing from this project to design work-zone sign support systems that are likely to provide safe impact performance for a wide range of passenger vehicles. A flowchart predicting MASH performance is shown in Figures 119 through 122. The flowchart only provides an estimate of the chance of failing the MASH criteria by excessive windshield and/or roof deformation as well as by penetration. Floorboard penetration should be analyzed on an individual system basis. X-footprint bases in the 0-degree orientation should be considered critical for failure by floorboard penetration with the pickup truck.

The flowcharts can be used to predict performance of work-zone, portable sign support systems with TL-3 impacts defined in MASH. The charts flow from the top starting with the vehicle type, then base type, mast height, sign panel height, breakaway mechanism height (for X-footprint base), orientation, and ending at the bottom with the predicted chance of failing MASH. Manufacturers can use the flowcharts when designing new systems to see which combinations of parameters may lead to an unsuccessful performance with the MASH criteria.

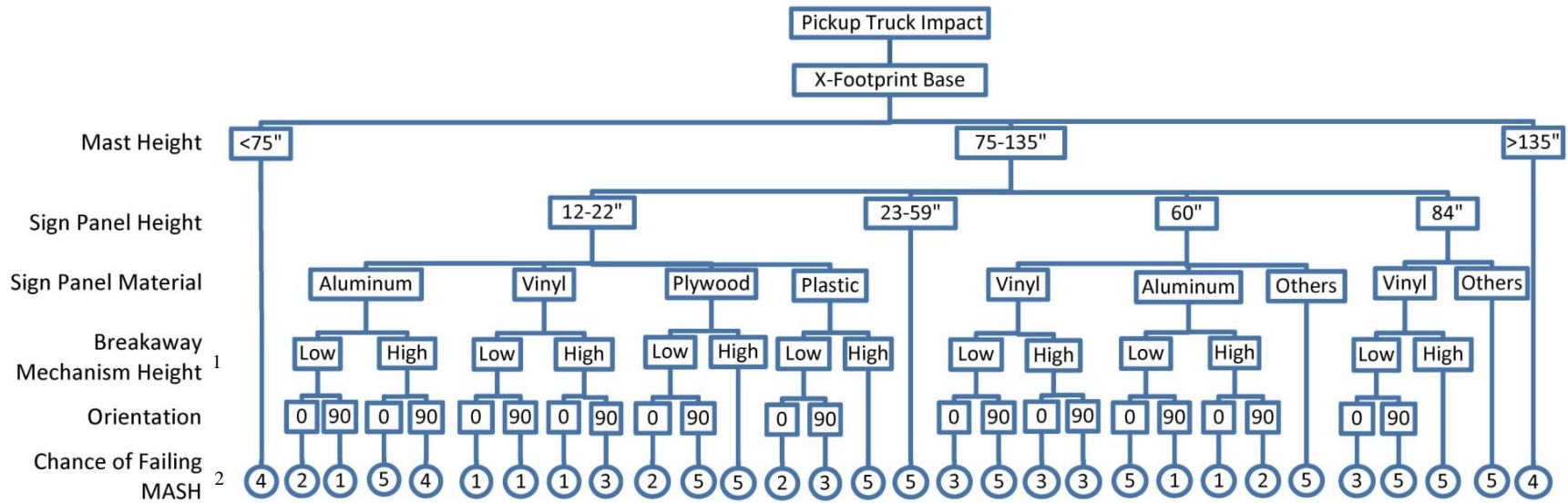

¹Breakaway Mechanism Height: Low ≤ 24", High > 24" or no breakaway mechanism

²Chance of Failing MASH: 1 - 75 to 100%, 2 - 50 to 75%, 3 - 25 to 50%, 4 - 0 to 25%, 5 - Unknown

Figure 119. TL-3 MASH Impact Prediction with Pickup Truck – X-Footprint Base

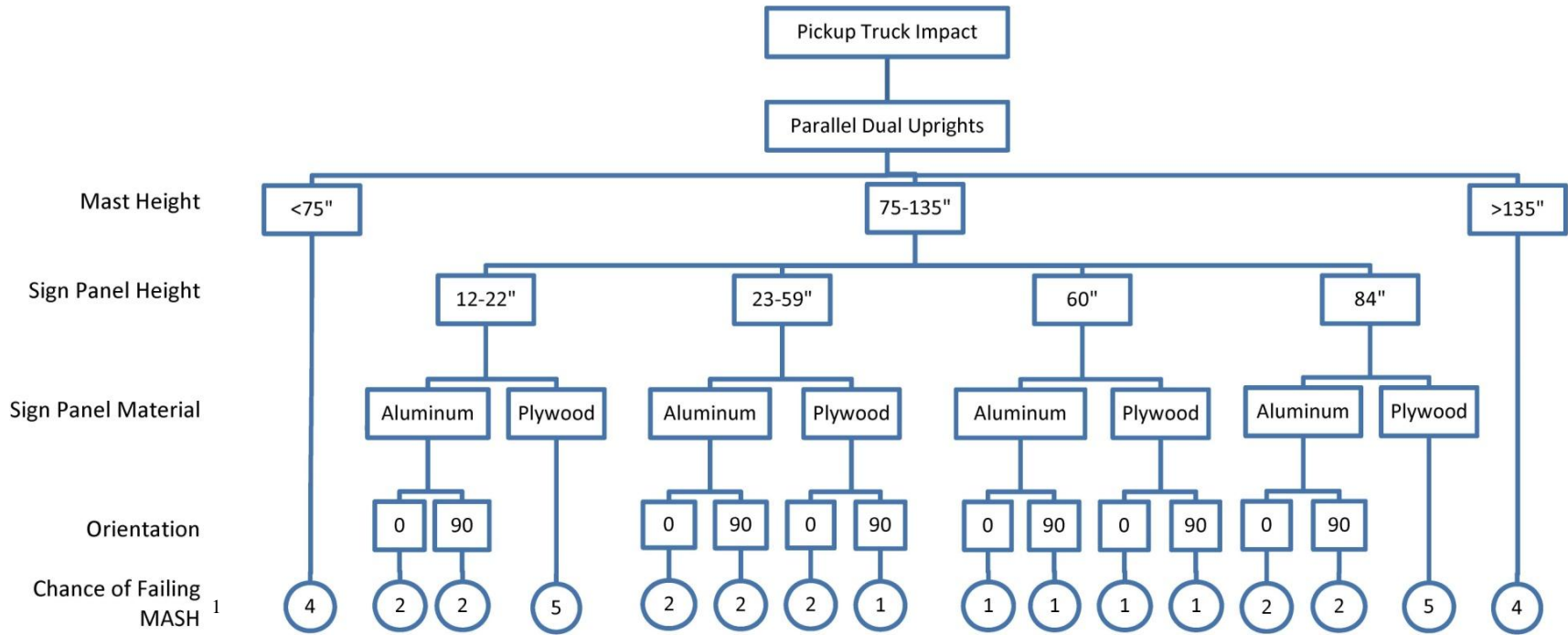

¹Chance of Failing MASH: 1 - 75 to 100%, 2 - 50 to 75%, 3 - 25 to 50%, 4 - 0 to 25%, 5 - Unknown

Figure 120. TL-3 MASH Impact Prediction with Pickup Truck – Parallel Dual Uprights

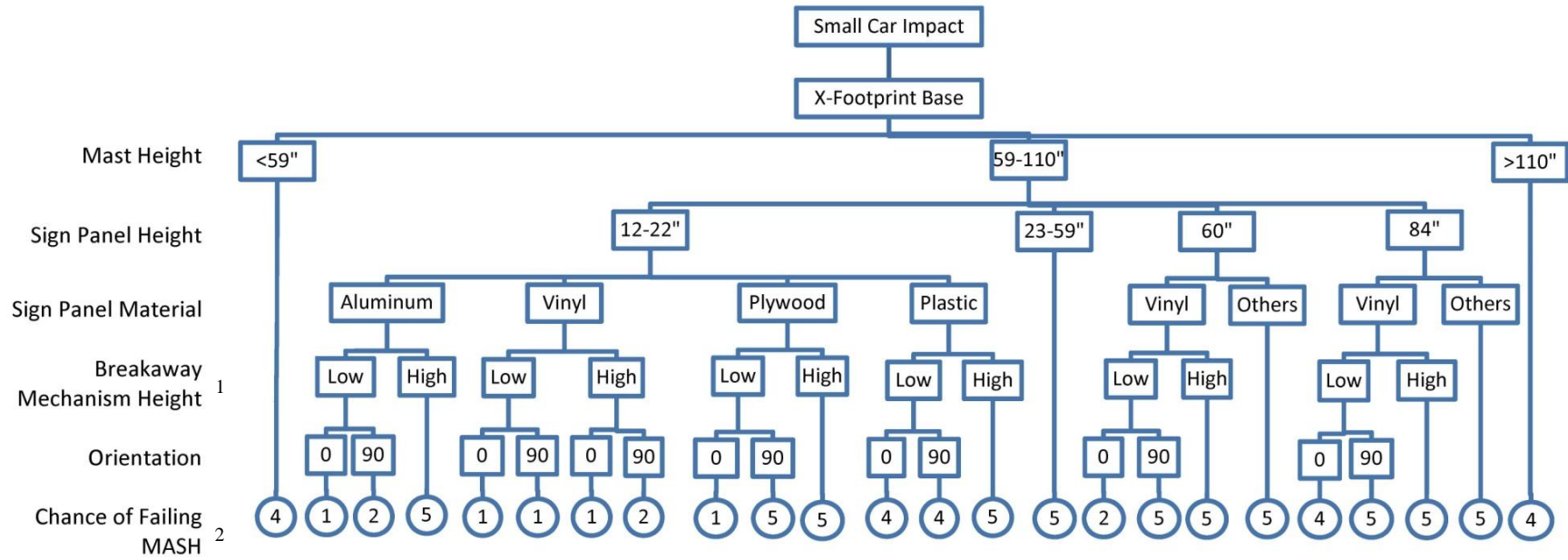

¹Breakaway Mechanism Height: Low ≤ 24", High > 24" or no breakaway mechanism

²Chance of Failing MASH: 1 - 75 to 100%, 2 - 50 to 75%, 3 - 25 to 50%, 4 - 0 to 25%, 5 - Unknown

Figure 121. TL-3 MASH Impact Prediction with Small Car – X-Footprint Base

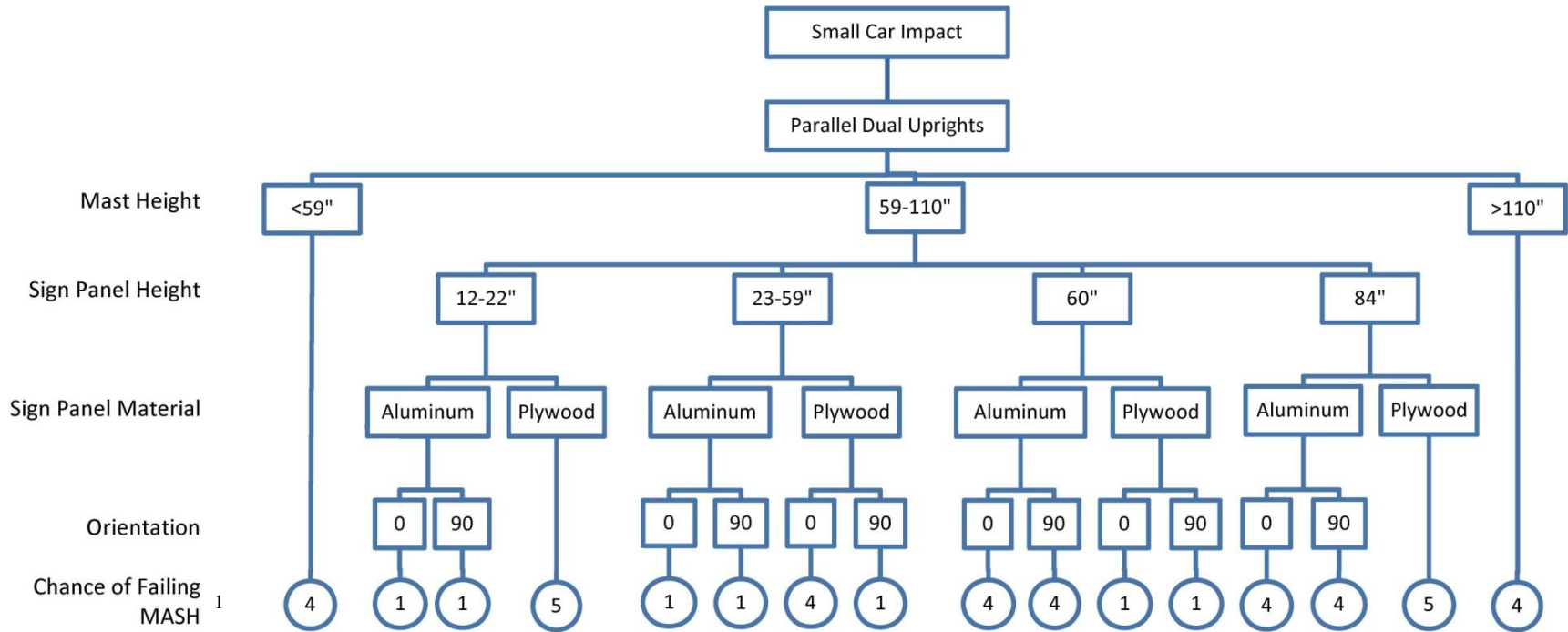

¹Chance of Failing MASH: 1 - 75 to 100%, 2 - 50 to 75%, 3 - 25 to 50%, 4 - 0 to 25%, 5 - Unknown

Figure 122. TL-3 MASH Impact Prediction with Small Car – Parallel Dual Uprights

15 REFERENCES

1. *Manual on Uniform Traffic Control Devices for Streets and Highways*. 2003 Edition with Revision 1 Dated November 2004 and Revision 2 Dated December 2007. U.S. Department of Transportation, Federal Highway Administration, 2003.
2. Ross, H.E., D.L. Sicking, R.A. Zimmer, and J.D. Michie. *Recommended Procedures for the Safety Performance Evaluation of Highway Features*. National Cooperative Highway Research Program (NCHRP) Report No. 350, Transportation Research Board, Washington, D.C., 1993.
3. Magdaleno, J.A., R.K. Faller, K.R. Kittrell, and E.R. Post. *Full-Scale Crash Tests on Plastic Drums with Type III Object Markers*. Final Report to the Missouri Highway and Transportation Department, Transportation Research Report No. 87-2, University of Nebraska-Lincoln, April 1988.
4. Polivka, K.A., R.K. Faller, J.C. Holloway, J.R. Rohde, and D.L. Sicking. *Crash Tests of Work Zone Traffic Control Devices*. Final Report to Dicke Tool Company, Transportation Research Report No. TRP-03-79-98, Midwest Roadside Safety Facility, University of Nebraska-Lincoln, December 7, 1998.
5. Polivka, K.A., R.K. Faller, J.C. Holloway, J.R. Rohde, and D.L. Sicking. *Crash Tests of Work Zone Traffic Control Devices – Phase II*. Final Report to Dicke Tool Company, Transportation Research Report No. TRP-03-81-99, Midwest Roadside Safety Facility, University of Nebraska-Lincoln, April 6, 1999.
6. Polivka, K.A., R.K. Faller, J.C. Holloway, J.R. Rohde, and D.L. Sicking. *Compliance Testing of Iowa's Skid-Mounted Sign Device*. Final Report to Iowa Department of Transportation, Transportation Research Report No. TRP-03-86-99, Midwest Roadside Safety Facility, University of Nebraska-Lincoln, July 23, 1999.
7. Polivka, K.A., R.K. Faller, J.C. Holloway, J.R. Rohde, and D.L. Sicking. *Crash Tests of Work Zone Traffic Control Devices – Phase III*. Final Report to Dicke Tool Company, Transportation Research Report No. TRP-03-87-99, Midwest Roadside Safety Facility, University of Nebraska-Lincoln, July 27, 1999.
8. Polivka, K.A., R.K. Faller, J.C. Holloway, J.R. Rohde, and D.L. Sicking. *Evaluation of Temporary Sign Stands and Flag Systems – Phase I*. Final Report to Lang Products International, Inc., Transportation Research Report No. TRP-03-82-99, Midwest Roadside Safety Facility, University of Nebraska-Lincoln, September 1, 1999.
9. Polivka, K.A., R.K. Faller, J.C. Holloway, J.R. Rohde, and D.L. Sicking. *Crash Testing of MDI's Portable Work Zone Signs – 1999 – Phase I*. Final Report to Marketing Displays International, Transportation Research Report No. TRP-03-89-99, Midwest Roadside Safety Facility, University of Nebraska-Lincoln, September 16, 1999.

10. Polivka, K.A., R.K. Faller, J.C. Holloway, J.R. Rohde, and D.L. Sicking. *Crash Tests of Work Zone Traffic Control Devices – Phase IV*. Final Report to Dicke Tool Company, Transportation Research Report No. TRP-03-92-99, Midwest Roadside Safety Facility, University of Nebraska-Lincoln, March 21, 2000.
11. Polivka, K.A., R.K. Faller, J.C. Holloway, J.R. Rohde, and D.L. Sicking. *Crash Tests of Endurance™ Work Zone Signs*. Final Report to Reflexite North America and General Electric Company, Transportation Research Report No. TRP-03-93-00, Midwest Roadside Safety Facility, University of Nebraska-Lincoln, May 19, 2000.
12. Polivka, K.A., R.K. Faller, J.C. Holloway, J.R. Rohde and D.L. Sicking. *Crash Tests of Work Zone Traffic Control Devices – Phase V*. Final Report to Dicke Tool Company, Transportation Research Report No. TRP-03-96-00, Midwest Roadside Safety Facility, University of Nebraska-Lincoln, July 18, 2000.
13. Polivka, K.A., R.K. Faller, J.C. Holloway, J.R. Rohde, and D.L. Sicking. *Safety Performance Evaluation of Minnesota’s Aluminum Type III Barricade*. Final Report to the Midwest State’s Regional Pooled Fund Program, Transportation Research Report No. TRP-03-101-00, Project No. SPR-3(017)-Year 10, Midwest Roadside Safety Facility, University of Nebraska-Lincoln, October 19, 2000.
14. Polivka, K.A., R.K. Faller, J.C. Holloway, J.R. Rohde, and D.L. Sicking. *Safety Performance Evaluation of Missouri’s Temporary Sign Stands*. Final Report to Missouri Department of Transportation, Transportation Research Report No. TRP-03-97-00, Midwest Roadside Safety Facility, University of Nebraska-Lincoln, December 13, 2000.
15. Polivka, K.A., R.K. Faller, J.C. Holloway, J.R. Rohde, and D.L. Sicking. *Safety Performance Evaluation of the PST-III Portable Type III Barricade*. Final Report to Plastic Safety Systems, Inc., Transportation Research Report No. TRP-03-103-00, Midwest Roadside Safety Facility, University of Nebraska-Lincoln, December 15, 2000.
16. Polivka, K.A., R.K. Faller, J.C. Holloway, J.R. Rohde, and D.L. Sicking. *Safety Performance Evaluation of Minnesota’s Aluminum Work Zone Signs*. Final Report to the Midwest State’s Regional Pooled Fund Research Program, Transportation Research Report No. TRP-03-107-01, Project No. SPR-3(017)-Year 11, Midwest Roadside Safety Facility, University of Nebraska-Lincoln, January 29, 2002.
17. Polivka, K.A., R.K. Faller, J.C. Holloway, J.R. Rohde, and D.L. Sicking. *Crash Tests of Work Zone Traffic Control Devices - Phase VI*. Final Report to Dicke Tool Company, Transportation Research Report No. TRP-03-112-01, Midwest Roadside Safety Facility, University of Nebraska-Lincoln, March 20, 2002.
18. Polivka, K.A., R.K. Faller, J.C. Holloway, J.R. Rohde, and D.L. Sicking. *Safety Performance Evaluation of Plastic Safety System’s Work Zone Devices*. Final

Report to Plastic Safety Systems, Inc., Transportation Research Report No. TRP-03-108-01, Midwest Roadside Safety Facility, University of Nebraska-Lincoln, August 7, 2002.

19. Jacoby, C.H. Federal Highway Administration (FHWA), *NCHRP 350 Approval Letter No. WZ-129 for D.P. Sawyer's Low Height Temporary Rigid Sign Panel Sign Stand*. To Ron Faller, Midwest Roadside Safety Facility, University of Nebraska-Lincoln, August 12, 2002.
20. Polivka, K.A., R.K. Faller, J.C. Holloway, and J.R. Rohde. *Safety Performance Evaluation of Minnesota's Low-Height, Temporary Rigid Panel Sign Stand*. Final Report to the Midwest State's Regional Pooled Fund Program, Transportation Research Report No. TRP-03-129-03, Project No. SPR-3(017)-Year 12, Midwest Roadside Safety Facility, University of Nebraska-Lincoln, January 23, 2003.
21. Polivka, K.A., R.K. Faller, J.C. Holloway, J.R. Rohde, and D.L. Sicking. *Safety Performance Evaluation of Michigan's Temporary Traffic Control Devices*. Final Report to the Michigan Department of Transportation, Transportation Research Report No. TRP-03-128-02, Midwest Roadside Safety Facility, University of Nebraska-Lincoln, January 27, 2003.
22. Polivka, K.A., R.K. Faller, J.C. Holloway, J.R. Rohde, and D.L. Sicking. *Safety Performance Evaluation of Michigan's 4x5 Portable Sign Support*. Final Report to the Michigan Department of Transportation, Transportation Research Report No. TRP-03-135-03, Midwest Roadside Safety Facility, University of Nebraska-Lincoln, June 20, 2003.
23. Baxter, J.R. Federal Highway Administration (FHWA), *NCHRP 350 Approval Letter No. WZ-141 for Dicke Tool's Portable Sign Stands*. To Grant Dicke, Dicke Tool Company, Downers Grove, Illinois, December 30, 2003.
24. Polivka, K.A., R.K. Faller, J.R. Rohde, J.C. Holloway, and D.L. Sicking. *Safety Performance Evaluation of Missouri's Ground-Mounted Temporary Sign Stands Phase II*. Final Report to the Missouri Department of Transportation, Transportation Research Report No. TRP-03-158-05, Midwest Roadside Safety Facility, University of Nebraska-Lincoln, March 8, 2005.
25. Baxter, J.R. Federal Highway Administration (FHWA), *NCHRP 350 Approval Letter No. WZ-213 for Dicke Tool's Portable Sign Stands*. To Paul Wander, Dicke Tool Company, Downers Grove, Illinois, October 13, 2005.
26. Polivka, K.A., R.K. Faller, J.C. Holloway, and J.R. Rohde. *Safety Performance Evaluation of Minnesota's Temporary Rigid Panel Sign Stand Systems*. Final Report to the Midwest States' Regional Pooled Fun Program, Transportation Research Report No. TRP-03-166-07, Project No. SPR-3(017)-Year 12, Midwest Roadside Safety Facility, University of Nebraska-Lincoln, February 8, 2007.
27. *Manual for Assessing Safety Hardware (MASH)*, American Association of State Highway

and Transportation Officials, Washington, D.C., 2009.

28. Bligh, R.P. and W.I. Menges. *Initial Assessment of Compliance of Texas Roadside Safety Hardware with Proposed Update to NCHRP Report 350*. Research Report No. 5526-1, Texas Transportation Institute, Texas A&M University, College Station, Texas, April 2007.
29. *Memorandum on Action: Identifying Acceptable Highway Safety Features*. 25 July 1997. File Designation HNG-14. Washington, D.C.: Federal Highway Administration (FHWA), 1997.
30. Federal Highway Administration (FHWA) *Windshield Damage for Category II Work Zone Traffic Control Devices Guidance For Pass/Fail*. November 2005. http://safety.fhwa.dot.gov/roadway_dept/policy_guide/road_hardware/memo1105/attach3a.cfm (accessed 12 April 2009).
31. Hinch, J., T.L. Yang, and R. Owings. *Guidance Systems for Vehicle Testing*. Springfield, VA: ENSCO, Inc., 1986.
32. *Center of Gravity Test Code - SAE J874 March 198*,. *SAE Handbook Vol. 4*. Warrendale, PA: Society of Automotive Engineers, Inc., 1986.
33. *Vehicle Damage Scale for Traffic Investigators*. Second Edition. Technical Bulletin No. 1, Traffic Accident Data (TAD) Project. Chicago, IL: National Safety Council, 1971.
34. *Collision Deformation Classification – Recommended Practice J224 March 1980*. Handbook Volume 4. Warrendale, PA: Society of Automotive Engineers (SAE), 1985.
35. Halquist, J.O. *LS-DYNA Keyword User's Manual*. Version 971. Livermore, CA: Livermore Software Technology Corporation, May 2007.
36. Meyer, C. and J.D. Schmidt. *Material Definition & Analysis*. ME950 Impact Engineering Project 2. 12 November 2008.
37. Clark, M., M. Richart, J. Schmidt, A. Stutzman. *Tension Test of Metals*. CE378 Materials of Construction Lab 1. 14 February 2007.

16 APPENDICES

Appendix A. Analysis Spreadsheets

Table A-1. Predicted Chance of Failure for Sign Testing with Pickup Truck

50-100% Chance of Failure	50-100% Chance of Failure Compared to No. of Systems	No. of Systems Tested	(mm)	(in)
Base Layout				
1	20%	5	Ground mounted single post	
0	0%	1	H dual upright	
2	22%	9	H single upright	
17	61%	28	Parallel dual upright	
0	0%	9	Parallel dual upright w/braces	
0	0%	2	Rubberbase	
0	0%	2	Skid-mounted	
0	0%	6	Tripod	
32	28%	113	X	
52	30%	175	Total	
Base Type				
16	34%	47	Double vertical spring	
1	8%	12	Extension spring	
1	20%	5	Ground mounted	
5	31%	16	Mast slides into base	
14	47%	30	Mast slides over base	
0	0%	16	Rigid	
4	100%	4	Slipbase	
0	0%	2	Rubberbase connector	
11	30%	37	Torsion spring	
0	0%	6	Tripod	
52	30%	175	Total	
Height to Bottom of Sign			(mm)	(in)
5	13%	39	305	12
7	24%	29	380	15
10	28%	36	460	18
2	33%	6	600	24
1	20%	5	740	29
2	25%	8	915	36
1	100%	1	1245	49
20	54%	37	1525	60
4	31%	13	2135	84
0	0%	1	none	
52	30%	175	Total	

Table A-1. Predicted Chance of Failure for Sign Testing with Pickup Truck (cont.)

50-100% Chance of Failure	50-100% Chance of Failure Compared to No. of Systems	No. of Systems Tested	(mm)	(in)
Height to Top of Mast				
0	0%	3	950	37
0	0%	2	1200	47
0	0%	18	1500	59
1	13%	8	1900	75
4	44%	9	2100	83
19	49%	39	2300	91
0	0%	3	2600	102
10	100%	10	2800	110
1	20%	5	3200	126
15	58%	26	3350	132
0	0%	2	3600	142
0	0%	6	3800	150
2	5%	44	None	
52	30%	175	Total	
Height to Top of Flags				
			(mm)	(in)
0	0%	5	1900	75
0	0%	7	2400	94
2	11%	18	2600	102
5	36%	14	2800	110
7	44%	16	2900	114
3	43%	7	3000	118
0	0%	4	3200	126
1	25%	4	3800	150
8	40%	20	4000	157
0	0%	2	4200	165
0	0%	8	4400	173
26	37%	70	none	
52	30%	175	Total	
Base/Sign Holder Vertical Tubing Dimension				
			(mm)	(in)
0	0%	1	19	0.75
1	7%	14	26	1.02
0	0%	9	32	1.26
8	22%	37	38	1.50
24	33%	72	45	1.77
14	58%	24	51	2.01
1	25%	4	64	2.52
5	50%	10	none	
0	0%	4	unknown	
52	30%	175	Total	

Table A-1. Predicted Chance of Failure for Sign Testing with Pickup Truck (cont.)

50-100% Chance of Failure	50-100% Chance of Failure Compared to No. of Systems	No. of Systems Tested	(mm)	(in)
Base/Sign Holder Vertical Tubing Length				
1	25%	4	80	3
10	28%	36	140	6
5	25%	20	200	8
1	11%	9	280	11
13	38%	34	305	12
6	43%	14	340	13
10	38%	26	430	17
4	22%	18	600	24
0	0%	6	1500	59
2	0%	8	unknown	
52	30%	175	Total	
Base/Sign Holder Vertical Tubing Wall Thickness				
			(mm)	(in)
0	0%	13	1.5	0.06
7	32%	22	2	0.08
21	31%	68	2.5	0.10
17	36%	47	3	0.12
1	25%	4	3.5	0.14
1	14%	7	4.5	0.18
5	50%	10	none	
0	0%	4	unknown	
52	30%	175	Total	
Mast Stages				
5	33%	15	1	
43	39%	110	2	
2	50%	4	3	
2	4%	46	none	
52	30%	175	Total	
Mast Material				
24	32%	74	Aluminum	
26	47%	55	Steel	
2	4%	46	none	
52	30%	175	Total	
Mast Dimension				
			(mm)	(in)
3	100%	3	25	0.98
0	0%	3	32	1.26
25	31%	81	38	1.50
6	75%	8	45	1.77
12	52%	23	51	2.01
4	100%	4	57	2.24
0	0%	7	64	2.52
2	4%	46	none	
52	30%	175	Total	

Table A-1. Predicted Chance of Failure for Sign Testing with Pickup Truck (cont.)

50-100% Chance of Failure	50-100% Chance of Failure Compared to No. of Systems	No. of Systems Tested	(mm)	(in)
Mast Wall Thickness				
0	0%	2	1.5	0.06
6	67%	9	2	0.08
22	29%	77	2.5	0.10
14	74%	19	3	0.12
5	28%	18	3.5	0.14
2	100%	2	4	0.16
0	0%	2	4.5	0.18
2	4%	46	none	
52	30%	175	Total	
Sign Locking Mechanism				
0	0%	2	Channel Holder	
1	13%	8	Roll-up Bracket	
25	42%	60	Nut & Bolt	
6	24%	25	Panel Clips	
2	50%	4	Locking Pin	
4	24%	17	Crossbrace Lock	
11	52%	21	Rigid Brackets	
1	5%	19	Thumbscrew lock	
2	11%	18	Slide Over Lock	
0	0%	1	none	
52	30%	175	Total	
Sign Panel Material				
33	42%	79	Aluminum	
2	33%	6	Mesh	
1	25%	4	Plastic	
7	70%	10	Plywood	
9	12%	75	Vinyl	
0	0%	1	none	
52	30%	175	Total	
Aluminum Vertical Crossbrace Length				
1	20%	5	Full	
1	8%	13	Half	
0	0%	2	Quarter	
50	32%	155	None	
52	30%	175	Total	

Table A-1. Predicted Chance of Failure for Sign Testing with Pickup Truck (cont.)

50-100% Chance of Failure	50-100% Chance of Failure Compared to No. of Systems	No. of Systems Tested	(mm)	(in)
Fiberglass Vertical Crossbrace Thickness				
1	17%	6	5	0.20
1	5%	20	6	0.24
2	33%	6	7	0.28
2	15%	13	8	0.31
0	0%	8	9	0.35
4	25%	16	10	0.39
42	40%	106	none	
52	30%	175	Total	
Horizontal Crossbrace Thickness			(mm)	(in)
10	16%	64	5	0.20
1	7%	14	6	0.24
0	0%	1	7	0.28
0	0%	2	25	0.98
41	44%	94	none	
52	30%	175	Total	
Flag Staff Material				
0	0%	13	Fiberglass	
26	28%	93	Wood	
26	38%	69	none	
52	30%	175	Total	
Orientation				
28	27%	105	0°	
24	34%	70	90°	
52	30%	175	Total	

Table A-2. Predicted Chance of Failure for Sign Testing with Small Car

50-100% Chance of Failure	50-100% Chance of Failure Compared to No. of Systems	No. of Systems Tested	(mm)	(in)
Base Layout				
2	40%	5	Ground mounted single post	
0	0%	1	H dual upright	
2	22%	9	H single upright	
13	46%	28	Parallel dual upright	
2	22%	9	Parallel dual upright w/braces	
0	0%	2	Rubberbase	
0	0%	2	Skid-mounted	
1	17%	6	Tripod	
10	11%	95	X	
30	19%	157	Total	
Base Type				
1	3%	31	Double vertical spring	
0	0%	10	Extension spring	
2	40%	5	Ground mounted	
5	31%	16	Mast slides into base	
12	40%	30	Mast slides over base	
2	13%	16	Rigid	
0	0%	4	Slipbase	
0	0%	2	Rubberbase connector	
7	19%	37	Torsion spring	
1	17%	6	Tripod	
30	19%	157	Total	
Height to bottom of sign			(mm)	(in)
9	23%	39	300	12
4	16%	25	380	15
6	19%	32	460	18
2	33%	6	600	24
3	60%	5	740	29
3	38%	8	915	36
1	100%	1	1245	49
2	7%	29	1525	60
0	0%	11	2135	84
0	0%	1	none	
30	19%	157	Total	

Table A-2. Predicted Chance of Failure for Sign Testing with Small Car (cont.)

50-100% Chance of Failure	50-100% Chance of Failure Compared to No. of Systems	No. of Systems Tested	(mm)	(in)
Height to top of mast				
0	0%	3	950	37
0	0%	2	1200	47
6	33%	18	1500	59
3	38%	8	1900	75
7	78%	9	2100	83
7	21%	33	2300	91
0	0%	3	2600	102
2	20%	10	2800	110
0	0%	7	3200	126
0	0%	16	3350	132
0	0%	2	3600	142
0	0%	4	3800	150
5	12%	42	None	
30	19%	157	Total	
Height to top of flags				
			(mm)	(in)
1	20%	5	1900	75
0	0%	7	2400	94
3	17%	18	2600	102
1	10%	10	2800	110
3	21%	14	2900	114
1	14%	7	3000	118
0	0%	4	3200	126
0	0%	4	3800	150
1	8%	13	4000	157
0	0%	2	4200	165
0	0%	6	4400	173
20	30%	67	none	
30	19%	157	Total	
Base/Sign Holder Vertical Tubing Dimension				
			(mm)	(in)
0	0%	1	19	0.75
3	21%	14	26	1.02
2	22%	9	32	1.26
12	32%	37	38	1.50
7	12%	60	45	1.77
5	21%	24	51	2.01
0	0%	4	64	2.52
1	25%	4	none	
0	0%	4	unknown	
30	19%	157	Total	

Table A-2. Predicted Chance of Failure for Sign Testing with Small Car (cont.)

50-100% Chance of Failure	50-100% Chance of Failure Compared to No. of Systems	No. of Systems Tested	(mm)	(in)
Base/Sign Holder Vertical Tubing Length				
0	0%	4	80	3
9	25%	36	140	6
0	0%	16	200	8
0	0%	9	280	11
14	41%	34	305	12
2	14%	14	340	13
2	11%	18	430	17
2	13%	16	600	24
1	17%	6	1500	59
0	0%	4	unknown	
30	19%	157	Total	
Base/Sign Holder Vertical Tubing Wall Thickness				
			(mm)	(in)
2	15%	13	1.5	0.06
5	23%	22	2	0.08
4	7%	56	2.5	0.10
15	32%	47	3	0.12
0	0%	4	3.5	0.14
3	43%	7	4.5	0.18
1	25%	4	none	
0	0%	4	unknown	
30	19%	157	Total	
Mast Stages				
1	7%	15	1	
22	23%	94	2	
0	0%	4	3	
7	16%	44	none	
30	19%	157	Total	
Mast Material				
6	10%	60	Aluminum	
17	32%	53	Steel	
7	16%	44	none	
30	19%	157	Total	
Mast Dimension				
			(mm)	(in)
0	0%	1	25	0.98
0	0%	3	32	1.26
9	13%	67	38	1.50
2	25%	8	45	1.77
10	43%	23	51	2.01
0	0%	4	57	2.24
2	29%	7	64	2.52
7	16%	44	none	
30	19%	157	Total	

Table A-2. Predicted Chance of Failure for Sign Testing with Small Car (cont.)

50-100% Chance of Failure	50-100% Chance of Failure Compared to No. of Systems	No. of Systems Tested	(mm)	(in)
Mast Wall Thickness				
0	0%	2	1.5	0.06
1	14%	7	2	0.08
10	15%	65	2.5	0.10
1	6%	17	3	0.12
9	50%	18	3.5	0.14
2	100%	2	4	0.16
0	0%	2	4.5	0.18
7	16%	44	none	
30	19%	157	Total	
Sign Locking Mechanism				
0	0%	2	Channel Holder	
1	13%	8	Roll-up Bracket	
17	29%	58	Nut & Bolt	
1	5%	19	Panel Clips	
1	25%	4	Locking Pin	
3	18%	17	Crossbrace Lock	
2	15%	13	Rigid Brackets	
0	0%	17	Thumbscrew lock	
5	28%	18	Slide Over Lock	
0	0%	1	none	
30	19%	157	Total	
Sign Panel Material				
16	23%	69	Aluminum	
2	33%	6	Mesh	
0	0%	4	Plastic	
3	30%	10	Plywood	
9	13%	67	Vinyl	
0	0%	1	none	
30	19%	157	Total	
Aluminum Vertical Crossbrace Length				
0	0%	5	Full	
4	31%	13	Half	
1	50%	2	Quarter	
25	18%	137	None	
30	19%	157	Total	

Table A-2. Predicted Chance of Failure for Sign Testing with Small Car (cont.)

50-100% Chance of Failure	50-100% Chance of Failure Compared to No. of Systems	No. of Systems Tested	(mm)	(in)
Fiberglass Vertical Crossbrace Thickness				
0	0%	6	5	0.20
2	10%	20	6	0.24
2	33%	6	7	0.28
1	11%	9	8	0.31
1	13%	8	9	0.35
2	17%	12	10	0.39
22	23%	96	none	
30	19%	157	Total	
Horizontal Crossbrace Thickness				
			(mm)	(in)
6	11%	56	5	0.20
4	29%	14	6	0.24
0	0%	1	7	0.28
1	50%	2	25	0.98
19	23%	84	none	
30	19%	157	Total	
Flag Staff Material				
1	8%	13	Fiberglass	
9	12%	77	Wood	
20	30%	67	none	
30	19%	157	Total	
Orientation				
18	19%	96	0°	
12	20%	61	90°	
30	19%	157	Total	

Appendix B. Material Specifications

US U.S. STANDARD SIGN
11400 ADDISON STREET
FRANKLIN PARK, IL 60131
1-800-537-4790 • 847-455-6606 • FAX 847-455-3330

MATERIAL CERTIFICATION

CUSTOMER ORDER NO. 39624.4554

U.S. STANDARD ORDER NO. USS21015

S
O
L
D

T
O

3-D Specialties, Inc.
Box 1615
1110 - 25th Avenue North
Fargo, ND 58107

PHYSICAL PROPERTIES (typ., approx. 60°F)

Tensile 39 ksi min.
Yield 32 ksi min.
Elongation 4 % min.

ITEM(S) .063/.080/.100 x various x various
5052-H38 aluminum sheet
SHIP DATE _____

CHEMICAL ANALYSIS: RANGES AND LIMITS Composition in % max. unless shown as a range or min.

Aluminum Alloy	Silicon		Iron		Copper	Manganese	Magnesium	Chromium	Zinc	Ti	Others		Aluminum
	1.0	Si + Fe	0.7	0.7	0.05-0.20	0.05			0.10		Each	Total	
											0.05	0.15	
1100	1.0	Si + Fe	0.7	0.7	0.05-0.20	0.05			0.10		0.05	0.15	99.00 Min.
2011	0.40		0.7	0.7	5.0-6.0				0.30		0.05 ¹	0.15	Remainder
2014	0.50-1.2		0.7	0.7	3.9-5.0	0.40-1.2	0.20-0.8	0.10	0.25	0.15	0.05	0.15	Remainder
2017	0.20-0.80		0.7	0.7	3.5-4.5	0.40-1.0	0.40-0.8	0.10	0.25	0.15	0.05	0.15	Remainder
2024	0.50	0.50	0.50	0.50	3.8-4.9	0.30-0.9	1.2-1.8	0.10	0.25	0.15	0.05	0.15	Remainder
2219	0.20	0.30	0.30	0.30	5.8-6.8	0.20-0.40	0.02		0.10	.02-1.0	0.05 ⁴	0.15	Remainder
3003	0.6		0.7	0.7	0.05-0.20	1.0-1.5			0.10		0.05	0.15	Remainder
3105	0.6		0.7	0.7	0.30	0.30-0.8	0.20-0.8	0.20	0.40	0.10	0.05	0.15	Remainder
5005	0.30		0.7	0.7	0.20	0.20	0.50-1.1	0.10	0.25		0.05	0.15	Remainder
** 5052	0.25		0.40	0.40	0.10	0.10	2.2-2.8	0.15-0.35	0.10		0.05	0.15	Remainder
5083	0.40		0.40	0.40	0.10	0.40-1.0	4.0-4.9	0.05-0.25	0.25	0.15	0.05	0.15	Remainder
5086	0.40		0.50	0.50	0.10	0.20-0.7	3.5-4.5	0.05-0.25	0.25	0.15	0.05	0.15	Remainder
5454	0.25		0.40	0.40	0.10	0.50-1.0	2.4-3.0	0.05-0.20	0.25	0.20	0.05	0.15	Remainder
5456	0.25		0.40	0.40	0.10	0.50-1.0	4.7-5.5	0.05-0.20	0.25	0.20	0.05	0.15	Remainder
5657	0.08		0.10	0.10	0.10	0.03	0.6-1.0		0.05		0.02 ²	0.05	Remainder
6061	0.40-0.8		0.7	0.7	0.15-0.40	0.15	0.8-1.2	0.04-0.35	0.25	0.15	0.05	0.15	Remainder
6063	0.20-0.6		0.35	0.35	0.10	0.10	0.45-0.9	0.10	0.10	0.10	0.05	0.15	Remainder
6282	0.40-0.8		0.7	0.7	0.15-0.40	0.15	0.8-1.2	0.04-0.14	0.25	0.15	0.05 ³	0.15	Remainder
7075	0.40		0.50	0.50	1.2-2.0	0.30	2.1-2.9	0.18-0.28	5.1-6.1	0.20	0.05	0.15	Remainder
CAST Tooling	1.0		1.10	1.10	0.70-1.60	1.00	0.8-2.1	0.30	2.2-4.2	0.25	0.05	0.15	Remainder
Alclad 2024 Clad	0.7	Si + Fe	0.50	0.50	0.10	0.05	.05		0.10	0.03	0.03 ⁴		99.30 Min.
Core	0.50		0.50	0.50	3.8-4.9	0.30-0.9	1.2-1.8	0.10	0.25		0.05	0.15	Remainder
Alclad 7075 Clad	0.7	Si + Fe	0.10	0.10	0.10	0.10	0.10		0.8-1.3		0.05	0.15	Remainder
Core	0.40		0.50	0.50	1.2-2.0	0.30	2.1-2.9	0.18-0.28	5.1-6.1	0.20	0.05	0.15	Remainder

¹Lead and Bismuth each 0.20-0.6%
⁴Vanadium 0.05-0.15%; Zirconium 0.10-0.25%

²Gallium 0.03% max; Vanadium 0.05% max

³Lead and Bismuth 0.40-0.7%
⁵Vanadium 0.05 Max.

We certify that the ORDER ITEM described on this document was shipped in accordance with your order. The producer of the material has certified to us that it conforms to the chemical composition limits shown above.

Barbara Skjerven
U. S. STANDARD SIGN CO.

Figure B-1. System No. 1B Sign Panel

ALLIED TUBE & CONDUIT

MECHANICAL TEST REPORT

CUSTOMER: M35451 ENJ COMPANY

PRODUCT SPECIFICATIONS ASTM(LATEST REV.):

ATC: N/A / N/A

COIL 618004 / HEAT 7380438: C%.170 MN%.470 P%.005 S%.004 SI% .001

DATE

<u>PRODUCED</u>	<u>PART NO.</u>	<u>DESCRIPTION</u>
5/21/08	74-1436	SQ RAW 1.750 X 12 X 288.375PSQ

FINISHED PRODUCT PROPERTIES

<u>U.T.S</u>	<u>Y.S.</u>	<u>-%E-</u>
<u>ksi(MPa)</u>	<u>ksi(MPa)</u>	<u>2IN</u>
62.2[430]	48.4[335]	52.0

We hereby certify the above is correct as contained in the records of the Corporation.

TERMS AND CONDITIONS OF SALE

This report is for informational purposes only. Allied sells only on the terms and conditions set forth in its quotation and acknowledgment forms.

WARRANTY INFORMATION

All warranties made by Allied Tube & Conduit on its products and all applicable warranty limitations, disclaimers and other information regarding warranties are contained exclusively in Allied's quotation and acknowledgement forms and are available upon request. Nothing contained herein shall give rise to or amend any expressed or implied warranties or any disclaimers or limitation thereof.

6/23/08

MTR-01 REV B

Figure B-2. System No. 1B Legs Square Tubing

Appendix C. Dimensional Measurements of Portable Sign Supports

Table C-1. Portable Sign Support System Dimensional Measurements

Stand Type	LEGS							
	Material	Telescoping Legs? (Y or N)	Non-Telescoping			Telescoping		
			Tubing Dimension (in. sqr.)	Length (in.)	Tube Wall Thickness (in.)	Tubing Dimension (in. sqr.)	Length (in.)	Tube Wall Thickness (in.)
System No. 1A (X-footprint)	Aluminum	N	1.258	64 5/16	0.100	-	-	-
System No. 1B (II-footprint)	Telespar Steel Tubing	N	1.752	72	0.106	-	-	-
System No. 2A (X-footprint)	Aluminum	N	1.254	42 7/16	0.099	-	-	-
System No. 3A (X-footprint)	Aluminum	N	1.244	42 3/16	0.100	-	-	-
System No. 3B (X-footprint)	Aluminum	N	1.250	48 3/8	0.097	-	-	-
System No. 4A (X-footprint)	Steel	N	1.007	42 1/4	0.072	-	-	-
System No. 4B (X-footprint)	Steel	N	0.999	42 3/8	0.063	-	-	-

Table C-2. Portable Sign Support System Dimensional Measurements

Stand Type	Type of Sign Lock Mechanism (Check One)					Double Torsion Spring? (Y or N)	Double Vertical Spring? (Y or N)	Rigid w/ Metal Leg Flanges? (Y or N)
	Slide Over Lock	Roll-up Bracket	Thumbscrew Lock	Nut & Bolt	Rigid Bracket			
System No. 1A (X-footprint)					X	N	Y	N
System No. 1B (II-footprint)				X		N	N	N
System No. 2A (X-footprint)					X	N	Y	N
System No. 3A (X-footprint)					X	N	Y	N
System No. 3B (X-footprint)		X				N	Y	N
System No. 4A (X-footprint)		X				N	Y	N
System No. 4B (X-footprint)					X	N	Y	N

Table C-3. Portable Sign Support System Dimensional Measurements

Stand Type	BASE/SIGN HOLDER						MAXIMUM	
	Lower (or Only) Vertical Tubing			Upper Vertical Tubing (Outer Sleeve)			Base Width (in.)	Base Length (in.)
	Dimension (in. sqr.)	Length (in.)	Thickness (in.)	Dimension (in. sqr.)	Length (in.)	Thickness (in.)		
System No. 1A (X-footprint)	1.759	8	0.102	-	-	-	47 1/2	125 1/2
System No. 1B (II-footprint)	1.751	12	0.105	2.253	35 7/8	0.105	25 7/16	72
System No. 2A (X-footprint)	1.756	8 1/16	0.103	-	-	-	32 11/16	84 3/8
System No. 3A (X-footprint)	-	-	-	-	-	-	40 7/16	81 3/4
System No. 3B (X-footprint)	1.253	19	0.076	-	-	-	45 11/16	92 1/16
System No. 4A (X-footprint)	-	-	-	-	-	-	38 15/16	79 1/2
System No. 4B (X-footprint)	-	-	-	-	-	-	39 3/4	80 15/16

Table C-4. Portable Sign Support System Dimensional Measurements

Stand Type	MAST					
	Mast? (Y or N)	Number of Stages	Lower (or only) Tubing			
			Material	Tubing Dimension (in. sqr.)	Wall Thickness (in.)	Length (in.)
System No. 1A (X-footprint)	Y	2	Aluminum	1.502	0.101	57
System No. 1B (II-footprint)	Y	2	Steel	1.999	0.104	107 7/8
System No. 2A (X-footprint)	Y	2	Aluminum	1.502	0.105	39 5/8
System No. 3A (X-footprint)	Y	2	Aluminum	1.501	0.100	36 11/16
System No. 3B (X-footprint)	Y	2	Steel	1.250	0.080	26 3/8
System No. 4A (X-footprint)	Y	2	Steel	1.209	0.080	37
System No. 4B (X-footprint)	Y	2	Steel	1.001	0.063	46 1/16

Table C-5. Portable Sign Support System Dimensional Measurements

Stand Type	MAST							
	Middle Tubing				Upper Tubing			
	Material	Tubing Dimension (in. sqr.)	Wall Thickness (in.)	Length (in.)	Material	Tubing Dimension (in. sqr.)	Wall Thickness (in.)	Length (in.)
System No. 1A (X-footprint)	Aluminum	1.249	0.100	72	-	-	-	-
System No. 1B (II-footprint)	Aluminum	-	-	-	-	-	-	-
System No. 2A (X-footprint)	Aluminum	1.251	0.097	40	-	-	-	-
System No. 3A (X-footprint)	Aluminum	1.248	0.098	42 13/16	-	-	-	-
System No. 3B (X-footprint)	Steel	0.998	0.066	54 1/8	-	-	-	-
System No. 4A (X-footprint)	Steel	1.010	0.070	48 1/2	-	-	-	-
System No. 4B (X-footprint)	Steel	0.812	0.063	49 5/16	-	-	-	-

Table C-6. Portable Sign Support System Dimensional Measurements

Sign Type	CROSSBRACE — VERTICAL MEMBER						CENTER HUB	
	Material	Square Dimension (in. sqr.)	Wall Thickness (in.)	Thickness (in.)	Width (in.)	Length (in.)	Material	Leg Length (in.)
System No. 1A (rigid aluminum)	-	-	-	-	-	-	-	-
System No. 1B (rigid aluminum)	-	-	-	-	-	-	-	-
System No. 2A (rigid aluminum)	-	-	-	-	-	-	-	-
System No. 3A (rigid aluminum)	-	-	-	-	-	-	-	-
System No. 3B (vinyl rollup)	Fiberglass	-	-	0.245	1.223	65 1/2	-	-
System No. 4A (vinyl rollup)	Fiberglass	-	-	0.247	1.224	65 1/2	-	-
System No. 4B (rigid aluminum)	-	-	-	-	-	-	-	-

Table C-7. Portable Sign Support System Dimensional Measurements

Sign Type	CENTER HUB		CROSSBRACE — HORIZONTAL MEMBER					
	Square Dimension (in. sqr.)	Shape	Material	Square Dimension (in. sqr.)	Wall Thickness (in.)	Thickness (in.)	Width (in.)	Length (in.)
System No. 1A (rigid aluminum)	-	-	-	-	-	-	-	-
System No. 1B (rigid aluminum)	-	-	-	-	-	-	-	-
System No. 2A (rigid aluminum)	-	-	-	-	-	-	-	-
System No. 3A (rigid aluminum)	-	-	-	-	-	-	-	-
System No. 3B (vinyl rollup)	-	-	Fiberglass	-	-	0.183	1.221	65 1/2
System No. 4A (vinyl rollup)	-	-	Fiberglass	-	-	0.185	1.230	65 1/2
System No. 4B (rigid aluminum)	-	-	-	-	-	-	-	-

Table C-8. Portable Sign Support System Dimensional Measurements

Sign Type	PANEL						TOP FLAGS	
	Material	Thickness (in.)	Thickness at Seam (in.)	Length (in.)	Width (in.)	Color & Wordings	Flag	
							Material	Number of
System No. 1A (rigid aluminum)	Aluminum	0.074	-	48	48	blank	Vinyl	3
System No. 1B (rigid aluminum)	Aluminum	0.098	-	48	48	blank	-	None
System No. 2A (rigid aluminum)	Aluminum	0.075	-	48	48	blank	Vinyl	3
System No. 3A (rigid aluminum)	Aluminum	0.093	-	48	48	fl. orange Right Lane	Vinyl	3
System No. 3B (vinyl rollup)	Reflective Vinyl	0.026	-	48	48	fl. orange Stop	Vinyl	2
System No. 4A (vinyl rollup)	Reflective Vinyl	0.028	-	48	48	fl. orange Stop	Vinyl	3
System No. 4B (rigid aluminum)	Aluminum	0.093	-	48	48	fl. orange Right Lane	Vinyl	3

Table C-9. Portable Sign Support System Dimensional Measurements

Sign Type	TOP FLAGS							
	Flag			Staff				
	Thickness (in.)	Length (in.)	Width (in.)	Material	Length (in.)	Thickness (in.)	Width (in.)	Diameter (in.)
System No. 1A (rigid aluminum)	-	18	18 1/4	Wood	24 1/16	-	-	0.736
System No. 1B (rigid aluminum)	-	-	-	-	-	-	-	-
System No. 2A (rigid aluminum)	-	17 11/16	18 5/16	Wood	24	-	-	0.804
System No. 3A (rigid aluminum)	-	17 1/2	18 1/4	Wood	24	-	-	0.756
System No. 3B (vinyl rollup)	-	24 7/8	23 3/4	Wood	36	-	-	0.749
System No. 4A (vinyl rollup)	-	24 15/16	23 13/16	Wood	36	-	-	0.743
System No. 4B (rigid aluminum)	-	24 11/16	24 1/16	Wood	36	-	-	0.747

Table C-10. Portable Sign Support System Dimensional Measurements

System Numbers	HEIGHTS TO				Other General Information
	Bottom of Sign (in.)	Top of Sign (in.)	Top of Mast (in.)	Top of Flags (in.)	
System No. 1A	59 15/16	125 3/16	135 5/16	159 3/16	
System No. 1B	61 5/8	127 1/8	109 7/8	-	
System No. 2A	20 1/8	85 3/4	88 1/2	111	
System No. 3A	18	83 5/16	89	110 3/16	
System No. 3B	21	89 1/2	90 1/2	113 5/16	
System No. 4A	13 3/8	80 15/16	92 5/16	124 11/16	
System No. 4B	14 15/16	80 1/2	100 11/16	132 13/16	

Table C-11. Portable Sign Support System Dimensional Measurements

System Numbers	Test Numbers	STAND		SIGN	
		Type	Weight (lb)	Type	Weight (lb)
System No. 1A	WZ09-1	X-footprint with dual vertical springs	42	48 x 48 x 0.08 Aluminum	17
System No. 1B	WZ09-1	II-footprint with dual masts	86	48 x 48 x 0.10 Aluminum	22
System No. 2A	WZ09-2	X-footprint with dual vertical springs	32	48 x 48 x 0.08 Aluminum	17
System No. 3A	WZ09-3	X-footprint with dual vertical springs	33	48 x 48 x 0.08 Aluminum	19
System No. 3B	WZ09-3	X-footprint with dual vertical springs	33	48x48 Vinyl Rollup	6
System No. 4A	WZ09-4	X-footprint with dual vertical springs	37	48x48 Vinyl Rollup	6
System No. 4B	WZ09-4	X-footprint with dual extension springs	37	48 x 48 x 0.08 Aluminum	19

Table C-12. Tripod Portable Sign Support System Dimensional Measurements

Stand Type	LEGS					MAXIMUM	
	Material	Number of Legs	Tubing Dimension (in. sqr.)	Length (in.)	Tube Wall Thickness (in.)	Base Width (in.)	Base Length (in.)
System No. 2B (tripod)	Steel	3 - 2 Front	1.257	49 15/16	0.067	51 5/16	59
		- 1 Back	1.256	46 1/8	0.064		

Table C-13. Tripod Portable Sign Support System Dimensional Measurements

Stand Type	Distance Between		Top of Mast Height (in.)	Bolt Plate			Panel Lock Mechanism	
	Front Two Legs (in.)	Front and Back Legs (in.)		Thickness (in.)	Width (in.)	Length (in.)	Type	Thickness (in.)
System No. 2B (tripod)	48 3/4	56 5/16	72	U: 0.244	1.258	5.498	rigid bracket	0.075
				L: 0.250	1.262	3.192	panel clips	0.135

Table C-14. Tripod Portable Sign Support System Dimensional Measurements

Stand Type	MAST					
	Mast? (Y or N)	Number of Stages	Lower (or only) Tubing			
			Material	Tubing Dimension (in. sqr.)	Wall Thickness (in.)	Length (in.)
System No. 2B (tripod)	Y	1	Steel	1.002	0.066	54 3/16

Table C-15. Tripod Portable Sign Support System Dimensional Measurements

Sign Type	PANEL						TOP FLAGS	
	Material	Thickness (in.)	Thickness at Seam (in.)	Length (in.)	Width (in.)	Color & Wording	Flag	
							Material	Number of
System No. 2B (rigid aluminum)	Aluminum	0.080	-	48	48	blank	Vinyl	2

Table C-16. Tripod Portable Sign Support System Dimensional Measurements

Sign Type	TOP FLAGS							
	Flag			Staff				
	Thickness (in.)	Length (in.)	Width (in.)	Material	Length (in.)	Thickness (in.)	Width (in.)	Diameter (in.)
System No. 2B (rigid aluminum)	0.010	17 11/16	17 1/2	Wood	30 1/4	-	-	0.825

Table C-17. Tripod Portable Sign Support System Dimensional Measurements

System Numbers	HEIGHTS TO			Other General Information
	Bottom of Sign (in.)	Top of Sign (in.)	Top of Flags (in.)	
System No. 2B	14 11/16	72	88	

Table C-18. Tripod Portable Sign Support System Dimensional Measurements

System Numbers	Test Numbers	STAND		SIGN	
		Type	Weight (lb)	Type	Weight (lb)
System No. 2B	WZ09-2	Tripod	19	48 x 48 x 0.08 Aluminum	18

Appendix D. Vehicle Center of Gravity Determination

WZ09-1 Vehicle: Ram 1500

		Vehicle CG Determination			HOR M	Vert M
VEHICLE	Equipment	Weight	Long CG	Vert CG		
+	Unbalasted Truck(Curb)	5119	62.1343	28.20813	318065.5	144397.4
+	Brake receivers/wires	6	105	51	630	306
+	Brake Frame	5	36.5	26	182.5	130
+	Brake Cylinder (Nitrogen)	22	76	28	1672	616
+	Strobe/Brake Battery	6	73	29	438	174
+	Hub	27	0	14.75	0	398.25
+	CG Plate (EDRs)	8	57.5	32.5	460	260
-	Battery	-42	-7	38.5	294	-1617
-	Oil	-9	6	17	-54	-153
-	Interior	-78	66	45	-5148	-3510
-	Fuel	-161	107	20	-17227	-3220
-	Coolant	-21	-23	35	483	-735
-	Washer fluid	-2	-15	36	30	-72
BALLAST	Water	85	107	20	9095	1700
	DTS Rack	20	72.5	26.5	1450	530
	Misc.				0	0
TOTAL WEIGHT		4985			310371	139204.7
					62.26098	27.92471

wheel base	140.25	Calculated Test Inertial Weight		
MASH Targets	Targets	CURRENT	Difference	
Test Inertial Weight	5000	4985	-15.0	
Long CG	62	62.26	0.26098	
Vert CG	28	27.92	-0.07529	

Note, Long. CG is measured from front axle of test vehicle

Curb Weight		
	Left	Right
Front	1477	1375
Rear	1116	1151
FRONT	2852	
REAR	2267	
TOTAL	5119	

Actual test inertial weight (from scales)		
	Left	Right
Front	1470	1320
Rear	1028	1172
FRONT	2790	
REAR	2200	
TOTAL	4990	

Vehicle Mass Distribution, Test No. WZ09-1

Test: **WZ09-2**

Vehicle: **RIO**

		Vehicle CG Determination		
VEHICLE	Equipment	Weight	Long CG	HOR M
+	Unbalasted Car	2309	36.11	83380
+	Brake receivers/wires	9	127	1143
+	Brake Frame	5	29.5	147.5
+	Brake Cylinder	28	62.5	1750
+	Strobe Battery	5	56.5	282.5
+	Hub	13	0	0
+	CG Plate (EDRs)	15	41	615
+	DTS	20	48	960
-	Battery	-35	-9	315
-	Oil	-3	-8.5	25.5
-	Interior	-46	35	-1610
-	Fuel	-11	76	-836
-	Coolant	-7	-19	133
-	Washer fluid	0	-13	0
BALLAST	Water	90	76	6840
	Misc.			0
	Misc.			0
TOTAL WEIGHT		2392		93145.5
				38.94043

wheel base 94.75

MASH targets		CURRENT	Difference
Test Inertial Weight	2420 (+/-)55	2392	-28.0
Long CG	39 (+/-)4	38.94	-0.05957

Note, Long. CG is measured from front axle of test vehicle

Curb Weight		
	Left	Right
Front	685	744
Rear	450	430
FRONT	1429	
REAR	880	
TOTAL	2309	

Dummy = 166lbs.

Actual test inertial weight (from scales)		
	Left	Right
Front	708	701
Rear	483	512
FRONT	1409	
REAR	995	
TOTAL	2404	

Figure D-1. Vehicle Mass Distribution, Test No. WZ09-2

Test: **WZ09-3** Vehicle: **Rio (1100C)**

VEHICLE	Equipment	Vehicle CG Determination		HOR M
		Weight	Long CG	
+	Unbalasted Car	2309	36.11	83380
+	Brake receivers/wires	9	127	1143
+	Brake Frame	5	29.5	147.5
+	Brake Cylinder	28	62.5	1750
+	Strobe Battery	5	56.5	282.5
+	Hub	13	0	0
+	CG Plate (EDRs)	15	41	615
+	DTS	20	48	960
-	Battery	-35	-9	315
-	Oil	-3	-8.5	25.5
-	Interior	-46	35	-1610
-	Fuel	-11	76	-836
-	Coolant	-7	-19	133
-	Washer fluid	0	-13	0
BALLAST	Water	90	76	6840
	Misc.			0
	Misc.			0
TOTAL WEIGHT		2392		93145.5
				38.94043

wheel base 94.75

MASH targets	CURRENT	Difference
Test Inertial Weight	2420 (+/-)55	2392 -28.0
Long CG	39 (+/-)4	38.94 -0.05957

Note, Long. CG is measured from front axle of test vehicle

Curb Weight		
	Left	Right
Front	685	744
Rear	450	430
FRONT	1429	
REAR	880	
TOTAL	2309	

Dummy = 166lbs.

Actual test inertial weight (from scales)		
	Left	Right
Front	697	716
Rear	503	491
FRONT	1413	
REAR	994	
TOTAL	2407	

Figure D-2. Vehicle Mass Distribution, Test No. WZ09-3

WZ09-4		Vehicle: Ram 1500 (2270P)				
		Vehicle CG Determination				
VEHICLE	Equipment	Weight	Long CG	Vert CG	HOR M	Vert M
+	Unbalasted Truck(Curb)	5119	62.1343	28.20813	318065.5	144397.4
+	Brake receivers/wires	6	105	51	630	306
+	Brake Frame	5	36.5	27	182.5	135
+	Brake Cylinder (Nitrogen)	22	76	29	1672	638
+	Strobe/Brake Battery	6	73	29	438	174
+	Hub	27	0	14.75	0	398.25
+	CG Plate (EDRs)	8	57.5	32.5	460	260
-	Battery	-42	-7	38	294	-1596
-	Oil	-9	6	17	-54	-153
-	Interior	-78	66	35	-5148	-2730
-	Fuel	-161	107	20	-17227	-3220
-	Coolant	-21	-23	35	483	-735
-	Washer fluid	-2	-15	36	30	-72
BALLAST	Water	85	107	20	9095	1700
	DTS	20	72.5	27.5	1450	550
	Misc.				0	0
TOTAL WEIGHT		4985			310371	140052.7
					62.26098	28.09482

wheel base	140.25	Calculated Test Inertial Weight		
MASH Targets	Targets	CURRENT	Difference	
Test Inertial Weight	5000	4985	-15.0	
Long CG	62	62.26	0.26098	
Vert CG	28	28.09	0.09482	

Note, Long. CG is measured from front axle of test vehicle

Curb Weight		
	Left	Right
Front	1477	1375
Rear	1116	1151
FRONT	2852	
REAR	2267	
TOTAL	5119	

Actual test inertial weight (from scales)		
	Left	Right
Front	1418	1366
Rear	1091	1113
FRONT	2784	
REAR	2204	
TOTAL	4988	

Figure D-3. Vehicle Mass Distribution, Test No. WZ09-4

Appendix E. Vehicle Deformation Records

Roof Crush

TEST: WZ09-1
VEHICLE: Ram 1500

POINT	X	Y	Z	X'	Y'	Z'	DEL X	DEL Y	DEL Z
1	46.75	-18.5	-3.25	46.75	-18.5	-2.5	0	0	0.75
2	48.25	-9.5	-3.5	48	-9.5	-2	-0.25	0	1.5
3	48.25	0	-3.25	47.75	0	-1	-0.5	0	2.25
4	47.75	9.5	-2.5	47.25	9.5	0.75	-0.5	0	3.25
5	46.5	19.25	-1.5	46	19	1.25	-0.5	-0.25	2.75
6	38.75	-16	-6	39	-16.5	-5.75	0.25	-0.5	0.25
7	38.25	-5	-6.25	38.25	-5.5	-6	0	-0.5	0.25
8	37.75	6.5	-5.75	37.5	6	-5	-0.25	-0.5	0.75
9	37	17.5	-4.5	36.5	17	-3.75	-0.5	-0.5	0.75
10	26.5	-14.25	-6	26.5	-14.25	-6	0	0	0
11	26.5	-0.5	-5.75	26.25	-0.5	-5.75	-0.25	0	0
12	26.5	12.25	-5	26.5	12.5	-4.75	0	0.25	0.25
13	15.5	-17.5	-7.25	15.25	-17.25	-7.5	-0.25	0.25	-0.25
14	16	-0.5	-7.25	16	-0.5	-7	0	0	0.25
15	17	15	-6	16.75	15	-6.25	-0.25	0	-0.25
MAX.			48.5			44.75	0	0	-3.75
17							0	0	0
18							0	0	0
19							0	0	0
20							0	0	0
21							0	0	0
22							0	0	0
23							0	0	0
24							0	0	0
25							0	0	0
26							0	0	0
27							0	0	0
28							0	0	0
29							0	0	0
30							0	0	0
31							0	0	0

Max is at roof edge of glass, passenger side, 1.5inches in from roof seam.

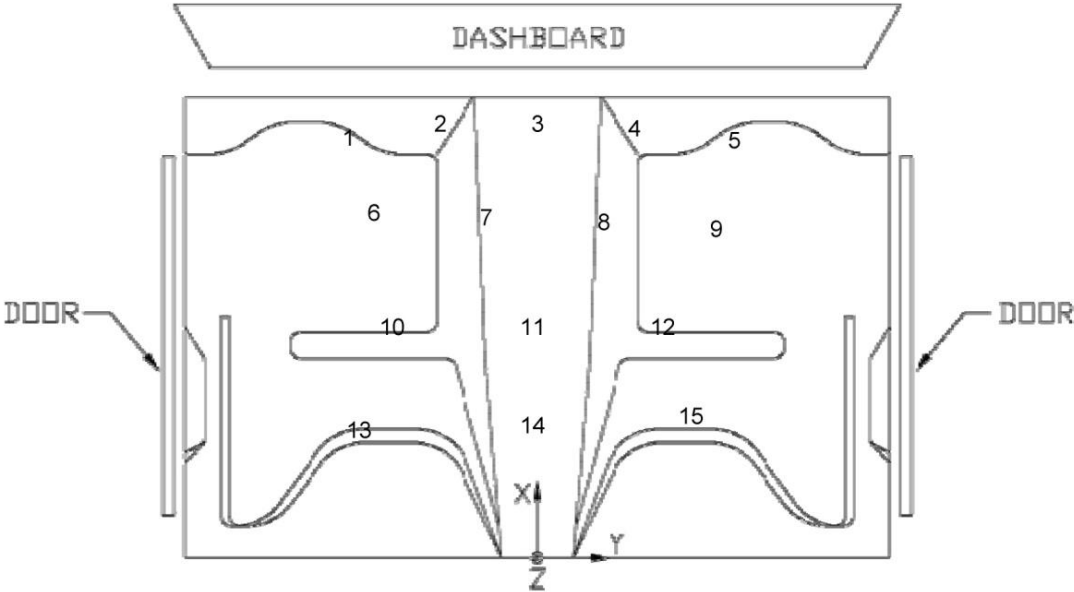

Figure E-1. Roof Deformation Data, Test No. WZ09-1

Windshield crush measurements

Test: WZ09-1

Date Measured: 4/23/2009

Crush measurements:

Location from passenger side roof corner of windshield

	Lateral (X)	Longitudinal (Y)	Pre test	Post test	Crush
Point 1	12	7	4	17	13
Point 2	28	14	2.25	11.25	9
Point 3	44	9	4.25	8.5	4.25
Max Crush	12	7	4	17	13



Figure E-2. Windshield Deformation Data, Test No. WZ09-1

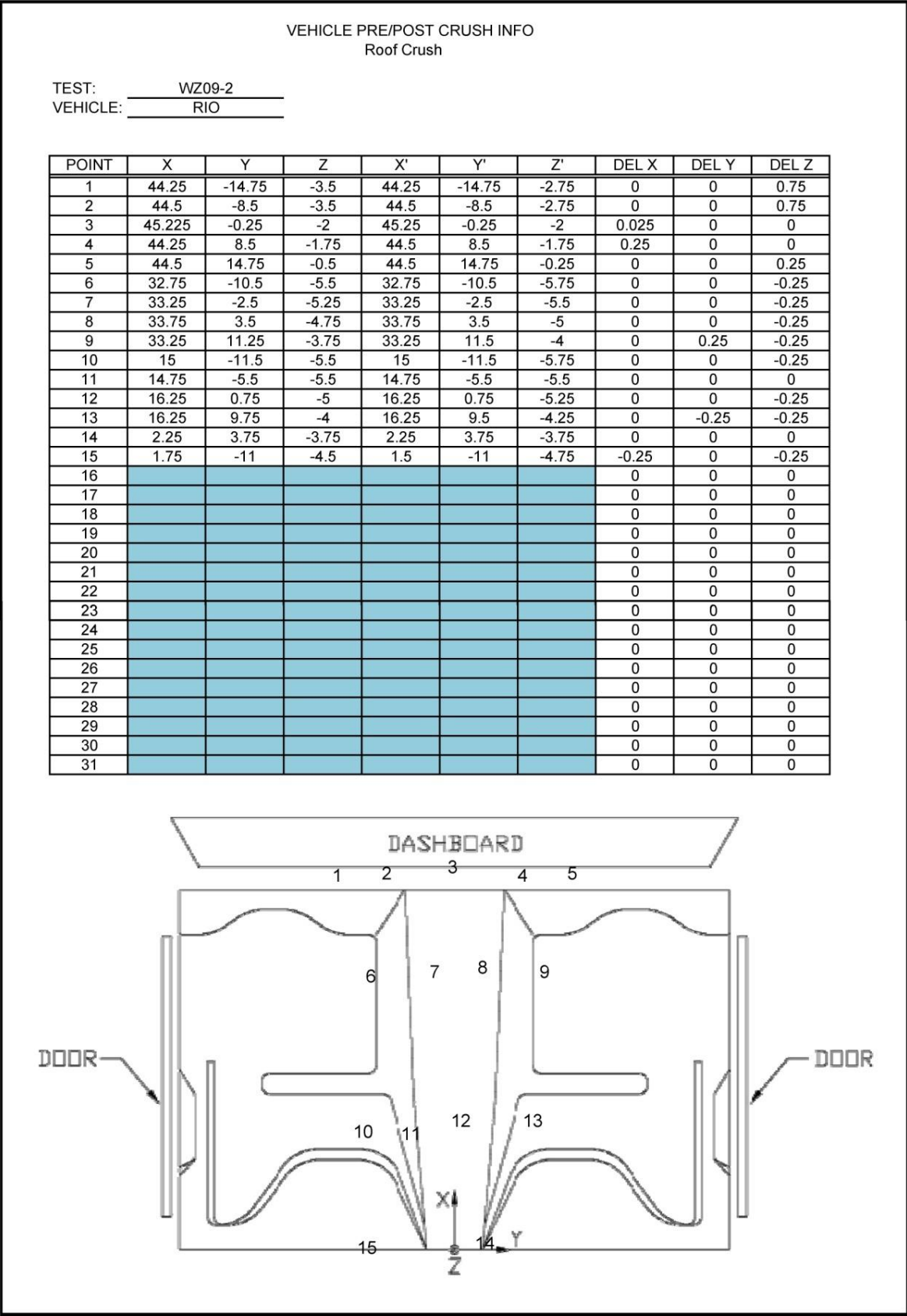

Figure E-3. Roof Deformation Data, Test No. WZ09-2

Windshield crush measurements

Test: WZ09-2

Date Measured: 5/28/2009

Crush measurements:

Location from passenger side upper roof corner of windshield (0,0)

	Lateral (X)	Longitudinal (Y)	Pre test	Post test	Crush
Point 1	9	11	5.25	7.5	2.25
Point 2	25	9	4.75	9.5	4.75
Point 3	26	13	4.75	12.5	7.75
Max Crush	12	13	4.75	12.5	7.75



Figure E-4. Windshield Deformation Data, Test No. WZ09-2

VEHICLE PRE/POST CRUSH
INTERIOR CRUSH - SET 1

TEST: WZ09-3
VEHICLE: Rio (1100C)

	POINT	X	Y	Z	X'	Y'	Z'	DEL X	DEL Y	DEL Z
DASH	A1							0	0	0
	A2	These points are not needed due to the type of barrier tested						#VALUE!	0	0
	A3							0	0	0
	A4							0	0	0
	A5							0	0	0
	A6							0	0	0
SIDE PANEL	B1							0	0	0
	B2	These points are not needed due to the type of barrier tested						#VALUE!	0	0
	B3							0	0	0
IMPACT SIDE DOOR	C1							0	0	0
	C2							0	0	0
	C3	These points are not needed due to the type of barrier tested						#VALUE!	0	0
	C4							0	0	0
	C5							0	0	0
	C6							0	0	0
ROOF	D1	43.75	-14.75	3.75	44.25	-14.5	3.5	0.5	0.25	-0.25
	D2	44.25	-8.5	4.5	44.5	-8.5	4.25	0.25	0	-0.25
	D3	45.25	-0.25	4.75	45	0	4.5	-0.25	0.25	-0.25
	D4	44.5	8.75	5	44.25	8.75	4.75	-0.25	0	-0.25
	D5	44.5	14.75	4.75	44.25	15	4.5	-0.25	0.25	-0.25
	D6	32.5	-10.5	6.25	32.5	-10.5	6.25	0	0	0
	D7	33.25	-2.5	7	33.75	-2.25	6.75	0.5	0.25	-0.25
	D8	33.75	3.5	7	33.25	3.5	7.25	-0.5	0	0.25
	D9	33.25	11.5	7	33.25	11.5	7	0	0	0
	D10	15	-11.75	4.5	14.75	-11.5	4.25	-0.25	0.25	-0.25
	D11	14.75	-5.75	5	14.75	-5.75	5	0	0	0
	D12	16.5	1	5.5	16.25	0.75	5.25	-0.25	-0.25	-0.25
	D13	16.25	9.5	5.5	16.25	9.5	5.5	0	0	0
	D14	2.25	3.75	3	2.25	3.5	3	0	-0.25	0
	D15	1.5	-11.25	2	1.75	-10.75	2	0.25	0.5	0

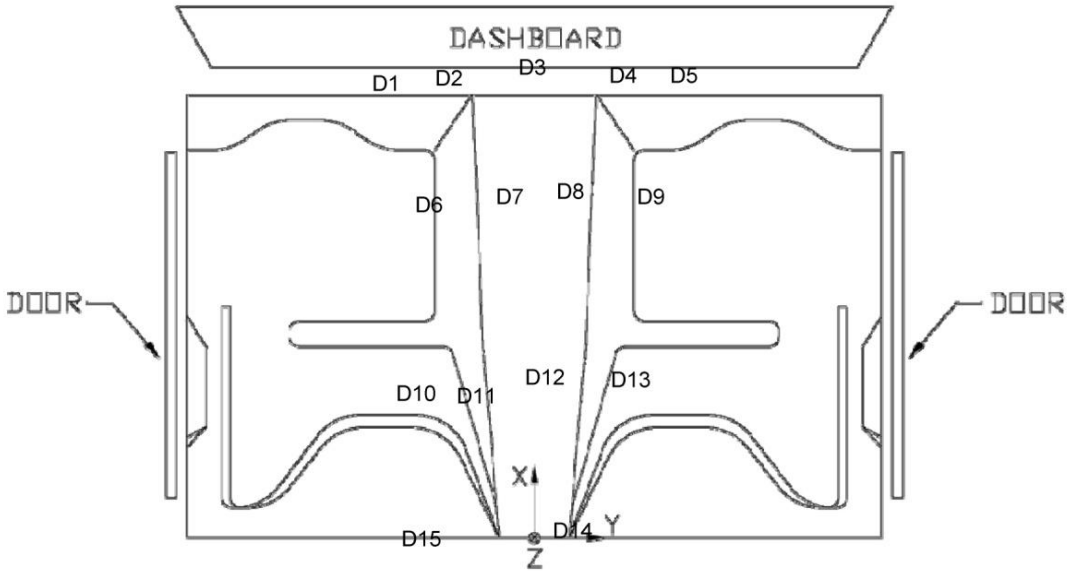

Figure E-5. Roof Deformation Data Set 1, Test No. WZ09-3

VEHICLE PRE/POST CRUSH
INTERIOR CRUSH - SET 2

TEST: WZ09-3
VEHICLE: Rio (1100C)

	POINT	X	Y	Z	X'	Y'	Z'	DEL X	DEL Y	DEL Z
DASH	A1							0	0	0
	A2							0	0	0
	A3	These points are not needed due to the type of barrier tested						#VALUE!	0	0
	A4							0	0	0
	A5							0	0	0
	A6							0	0 </td <td>0</td>	0
SIDE PANEL	B1							0	0	0
	B2	These points are not needed due to the type of barrier tested						#VALUE!	0	0
	B3							0	0	0
IMPACT SIDE DOOR	C1							0	0	0
	C2							0	0	0
	C3	These points are not needed due to the type of barrier tested						#VALUE!	0	0
	C4							0	0	0
	C5							0	0	0
	C6							0	0	0
ROOF	D1	34.75	-34	2	35	-34	2	0.25	0	0
	D2	34.75	-27.75	2.25	34.75	-27.75	2.25	0	0	0
	D3	35.25	-19.75	2	35	-19.5	1.75	-0.25	0.25	-0.25
	D4	34.5	-10.75	1.75	34.25	-10.75	1.5	-0.25	0	-0.25
	D5	35	-4.5	0.75	35	-4.5	0.75	0	0	0
	D6	22.75	-29.5	5.25	22.5	-29.5	5	-0.25	0	-0.25
	D7	23.25	-21.5	5	23.5	-21.5	5	0.25	0	0
	D8	23.75	-15.75	4.75	24	-16	4.75	0.25	-0.25	0
	D9	23.5	-7.75	4	23.5	-7.75	4	0	0	0
	D10	5	-30	4.5	5.25	-30	4.5	0.25	0	0
	D11	4.75	-24	4.75	4.75	-18	4.75	0	6	0
	D12	6.5	-17.75	4.75	6.25	-17.75	4.75	-0.25	0	0
	D13	6.5	-9	4	6.5	-8.75	4	0	0.25	0
	D14	-7.75	-14.5	3	-7.75	-14.5	3	0	0	0
	D15	-8.5	-29.25	3	-8.25	-29	3.25	0.25	0.25	0.25

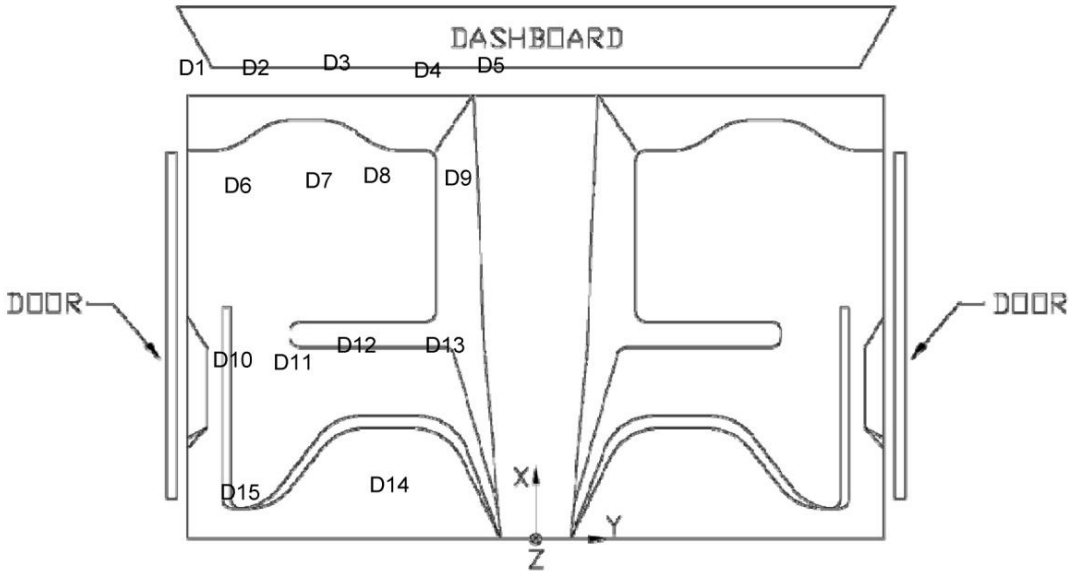

Figure E-6. Roof Deformation Data Set 2, Test No. WZ09-3

Windshield crush measurements

Test: WZ09-3

Date Measured: 9/16/2009

Crush measurements:

Location from the top passenger side roof corner of windshield

	Lateral (X)	Longitudinal (Y)	Pre test	Post test	Crush
Point A	6.5	14.5	5.25	9.25	4
Point B	15.5	17.75	4.5	8.25	3.75
Point C	23.75	10.5	5	7.75	2.75
Point D	34.75	12.25	5.5	7.75	2.25
Max Crush	6.5	14.75	5.25	9.25	4



Figure E-7. Windshield Deformation Data, Test No. WZ09-3

VEHICLE PRE/POST CRUSH
INTERIOR CRUSH - SET 1

TEST: WZ09-4
VEHICLE: Ram 1500 (2270P)

	POINT	X	Y	Z	X'	Y'	Z'	DEL X	DEL Y	DEL Z
DASH	A1							0	0	0
	A2	These points are not needed due to the type of barrier tested						#VALUE!	0	0
	A3							0	0	0
	A4							0	0	0
	A5							0	0	0
	A6							0	0	0
SIDE PANEL	B1							0	0	0
	B2	These points are not needed due to the type of barrier tested						#VALUE!	0	0
	B3							0	0	0
IMPACT SIDE DOOR	C1							0	0	0
	C2							0	0	0
	C3	These points are not needed due to the type of barrier tested						#VALUE!	0	0
	C4							0	0	0
	C5							0	0	0
	C6							0	0	0
ROOF	D1	46.75	-18.75	29.75	47	-18.5	29.5	0.25	0.25	-0.25
	D2	48.25	-9.75	29.75	48.25	-9.75	29.5	0	0	-0.25
	D3	48.25	0	29.5	48.25	0	29.5	0	0	0
	D4	47.75	9.5	29	47.5	9.75	29	-0.25	0.25	0
	D5	46.5	19	28	46.25	19.25	27.75	-0.25	0.25	-0.25
	D6	38.75	-16	31.75	38.75	-16	31.5	0	0	-0.25
	D7	38.25	-5.5	32	38.25	-5.25	32	0	0.25	0
	D8	37.75	6.5	31.25	37.75	6.5	31.25	0	0	0
	D9	37.25	17.25	30.25	37	17.25	30	-0.25	0	-0.25
	D10	26.5	-14.25	31	26.25	-14.25	30.75	-0.25	0	-0.25
	D11	26.5	-0.5	31	26.5	-0.5	30.75	0	0	-0.25
	D12	26.5	12.5	30	26.5	12.5	30	0	0	0
	D13	15.25	-17	32	15.5	-17.25	31.75	0.25	-0.25	-0.25
	D14	16	-0.25	31.75	16	-0.25	31.5	0	0	-0.25
	D15	17	15	30.75	16.75	15	30.75	-0.25	0	0

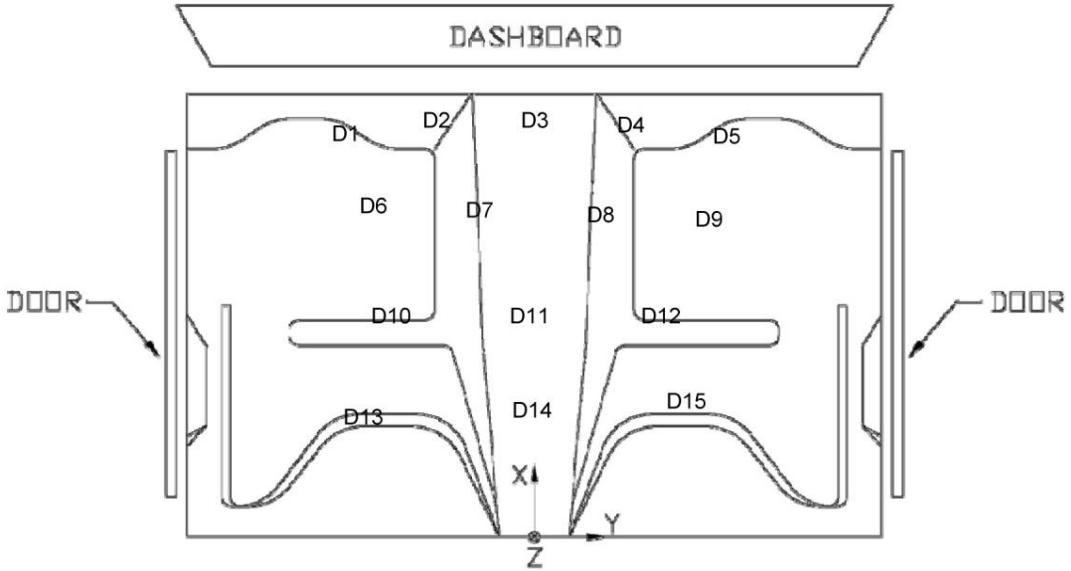

Figure E-8. Roof Deformation Data Set 1, Test No. WZ09-4

VEHICLE PRE/POST CRUSH
INTERIOR CRUSH - SET 2

TEST: WZ09-4
VEHICLE: Ram 1500 (2270P)

	POINT	X	Y	Z	X'	Y'	Z'	DEL X	DEL Y	DEL Z
DASH	A1							0	0	0
	A2							0	0	0
	A3	These points are not needed due to the type of barrier tested						#VALUE!	0	0
	A4							0	0	0
	A5							0	0	0
	A6							0	0	0
SIDE PANEL	B1							0	0	0
	B2	These points are not needed due to the type of barrier tested						#VALUE!	0	0
	B3							0	0	0
IMPACT SIDE DOOR	C1							0	0	0
	C2							0	0	0
	C3	These points are not needed due to the type of barrier tested						#VALUE!	0	0
	C4							0	0	0
	C5							0	0	0
	C6							0	0	0
ROOF	D1	53.75	-41	27.25	53.75	-41	27	0	0	-0.25
	D2	55.5	-32.25	28	55.25	-32.25	27.75	-0.25	0	-0.25
	D3	55.5	-22.5	28.5	55.5	-22.75	28.5	0	-0.25	0
	D4	54.75	-13	28.75	54.75	-13	29	0	0	0.25
	D5	53.25	-3.5	28.5	53	-3.5	28.5	-0.25	0	0
	D6	46	-38.75	30.5	46	-38.75	30.5	0	0	0
	D7	45.75	-28	31.5	54.5	-28	31.5	8.75	0	0
	D8	45	-16.25	32	45	-16.25	32	0	0	0
	D9	44.25	-5.5	32	44.25	-5.75	31.75	0	-0.25	-0.25
	D10	33.5	-36.5	31.25	33.75	-36.5	31.25	0.25	0	0
	D11	33.75	-23	32.25	33.75	-22.75	32	0	0.25	-0.25
	D12	33.75	-10	32.5	33.75	-10	32.5	0	0	0
	D13	23	-39.5	33	23	-39.5	33	0	0	0
	D14	23.75	-22.75	34	23.75	-22.75	34.25	0	0	0.25
	D15	24.5	-7.5	34.25	24.25	-7.5	34.25	-0.25	0	0

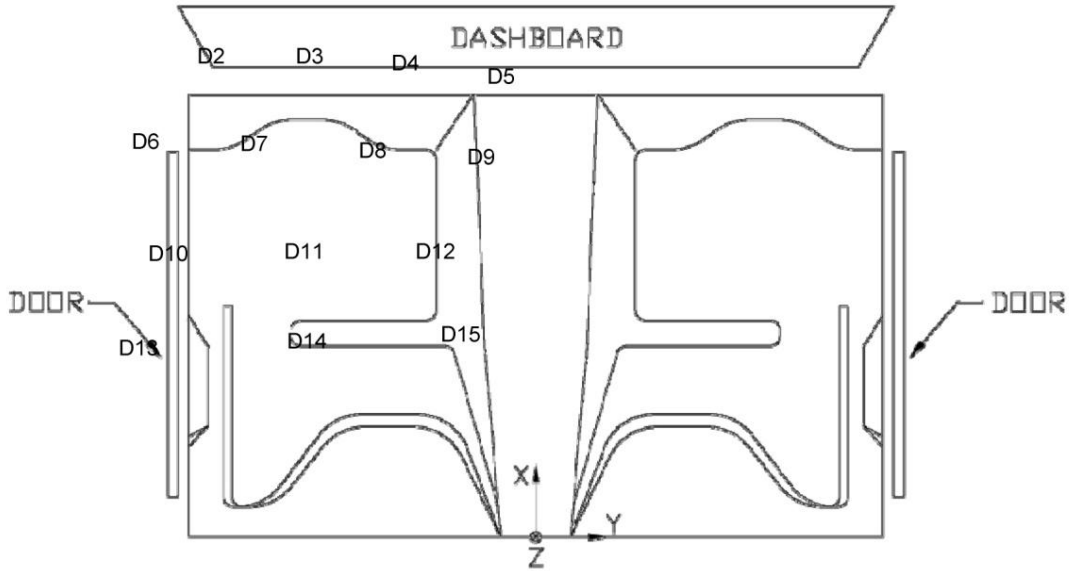

Figure E-9. Roof Deformation Data Set 2, Test No. WZ09-4

Appendix F. Accelerometer and Rate Transducer Plots, Test No. WZ09-1

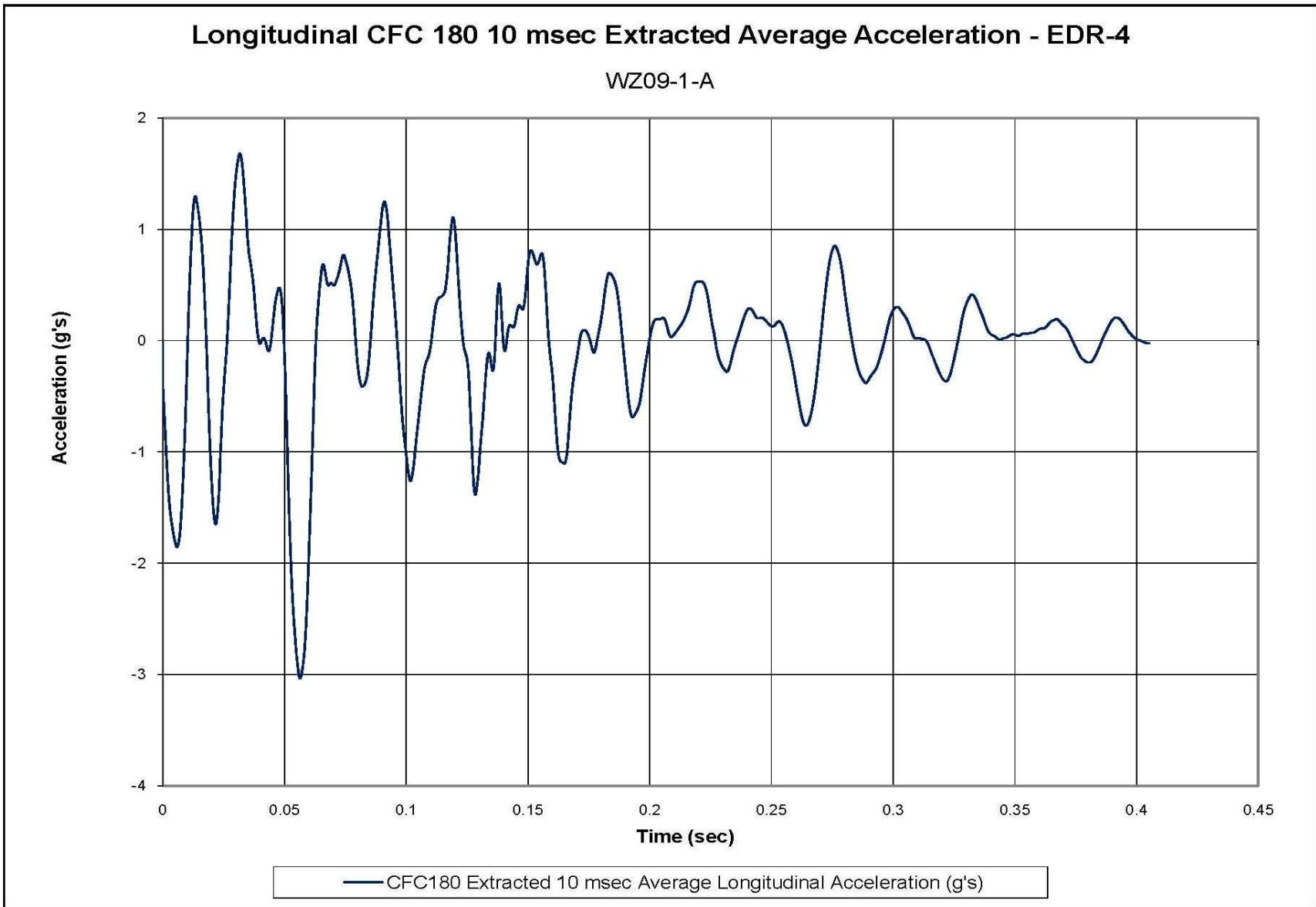

Figure F-1. 10-ms Average Longitudinal Deceleration (EDR-4), Test No. WZ09-1A

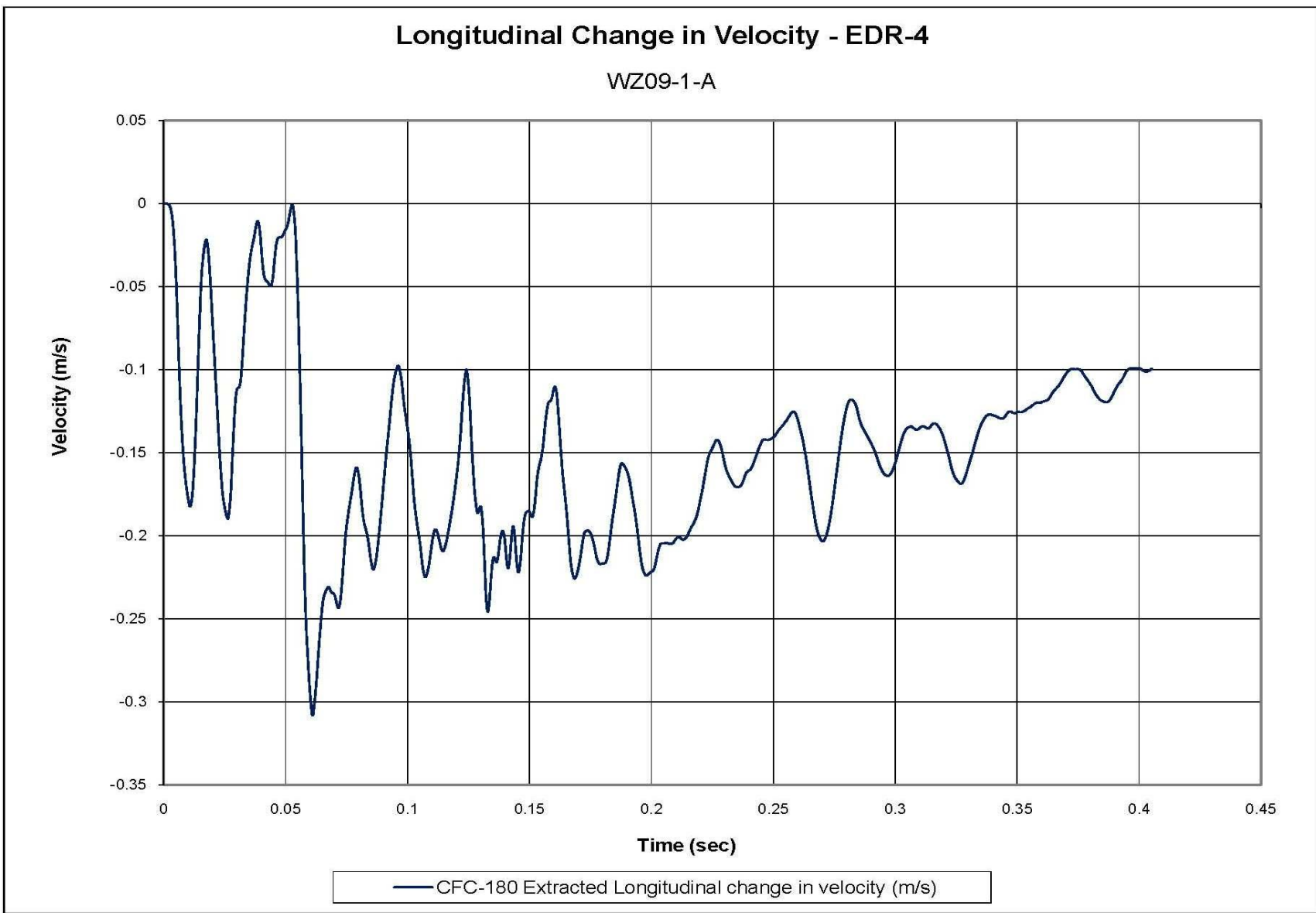

Figure F-2. Longitudinal Occupant Impact Velocity (EDR-4), Test No. WZ09-1A

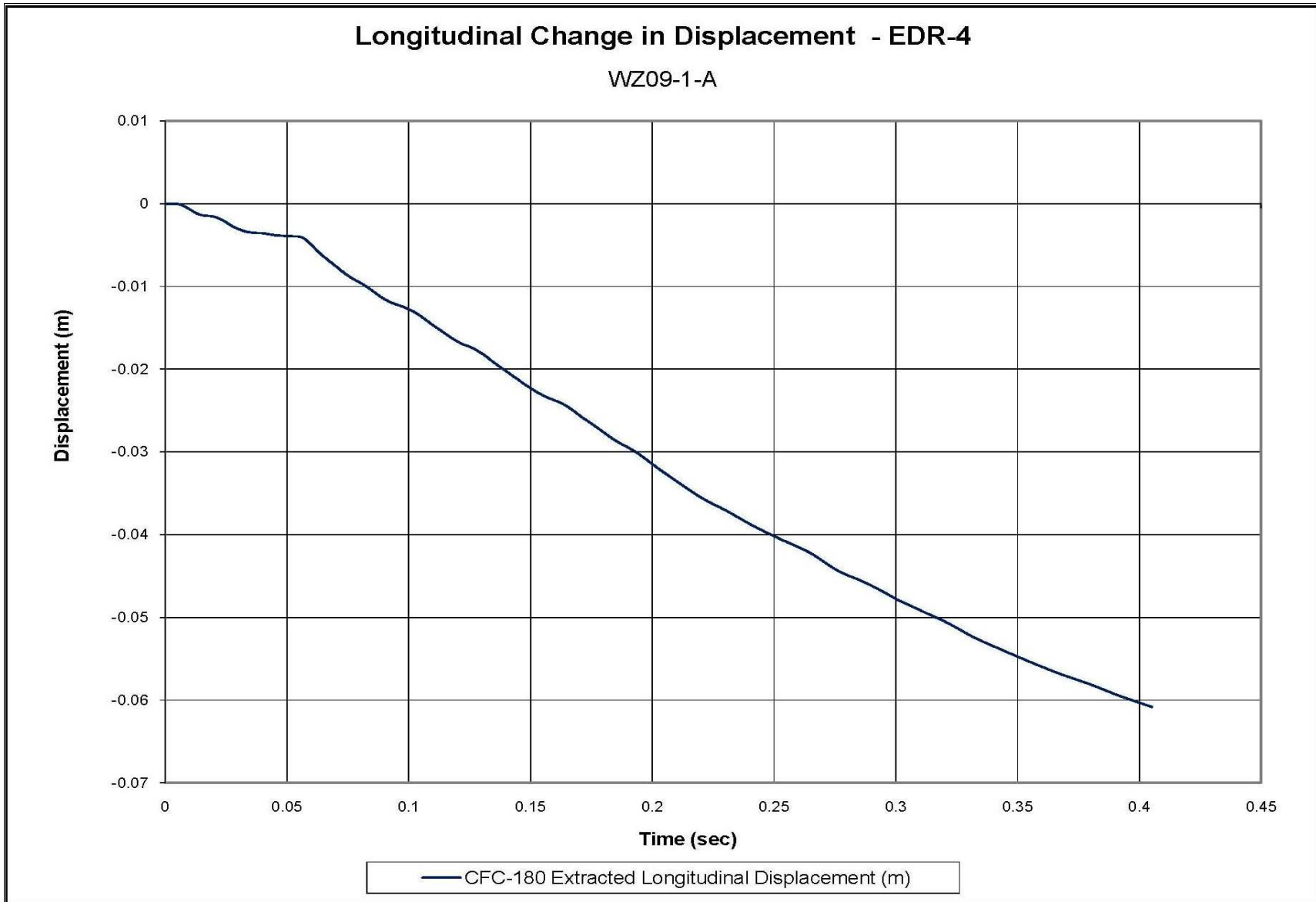

Figure F-3. Longitudinal Occupant Displacement (EDR-4), Test No. WZ09-1A

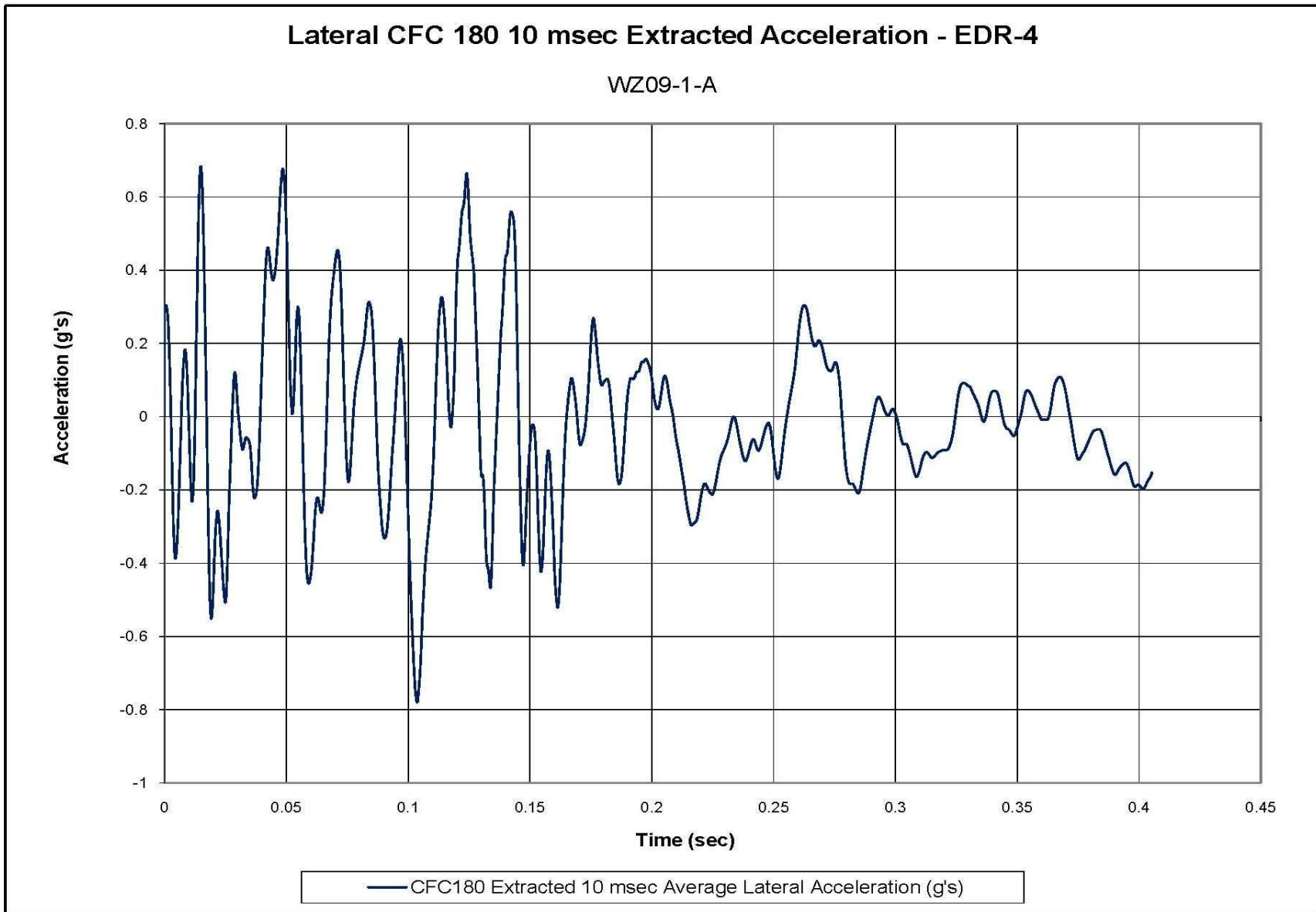

Figure F-4. 10-ms Average Lateral Deceleration (EDR-4), Test No. WZ09-1A

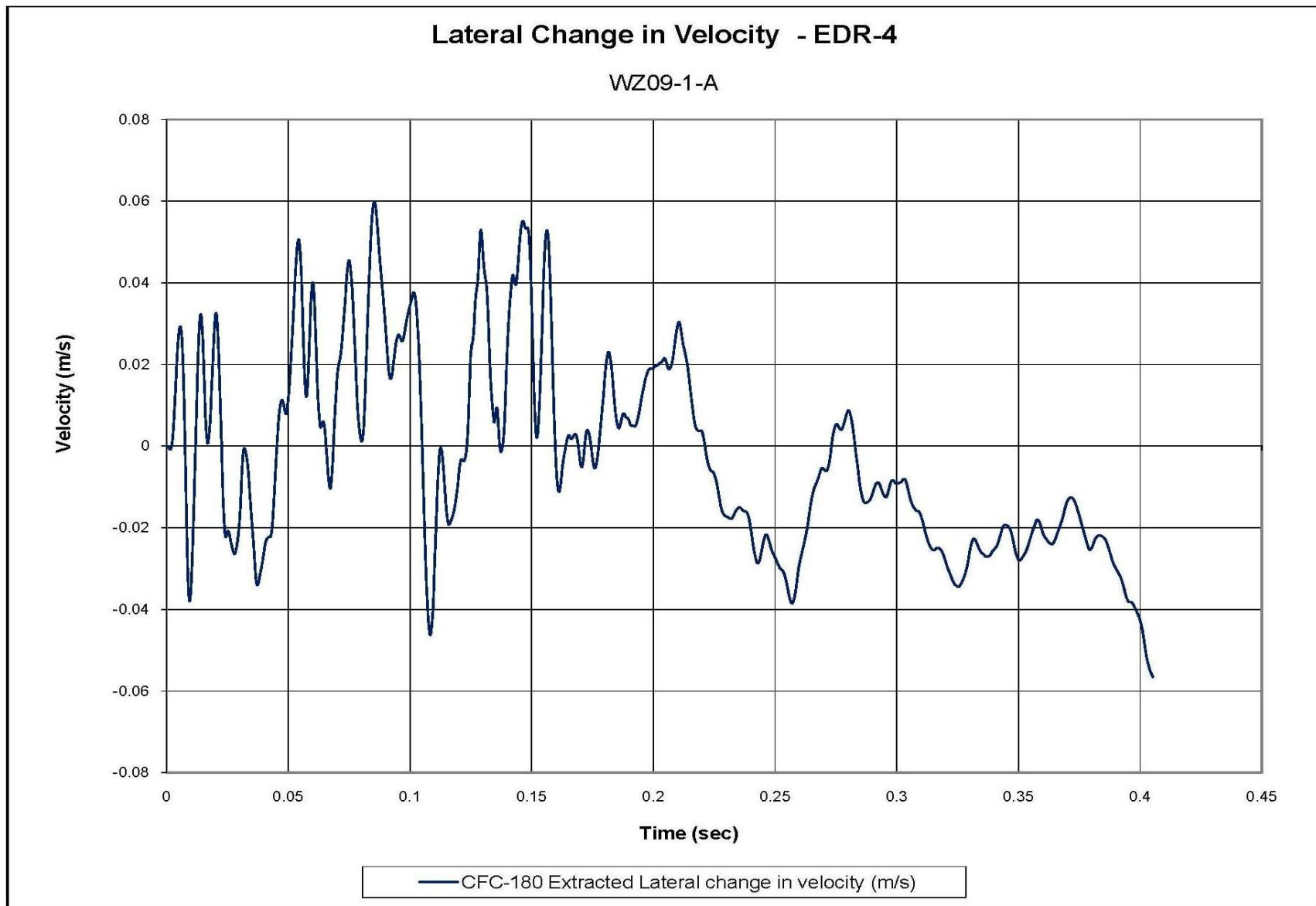

Figure F-5. Lateral Occupant Impact Velocity (EDR-4), Test No. WZ09-1A

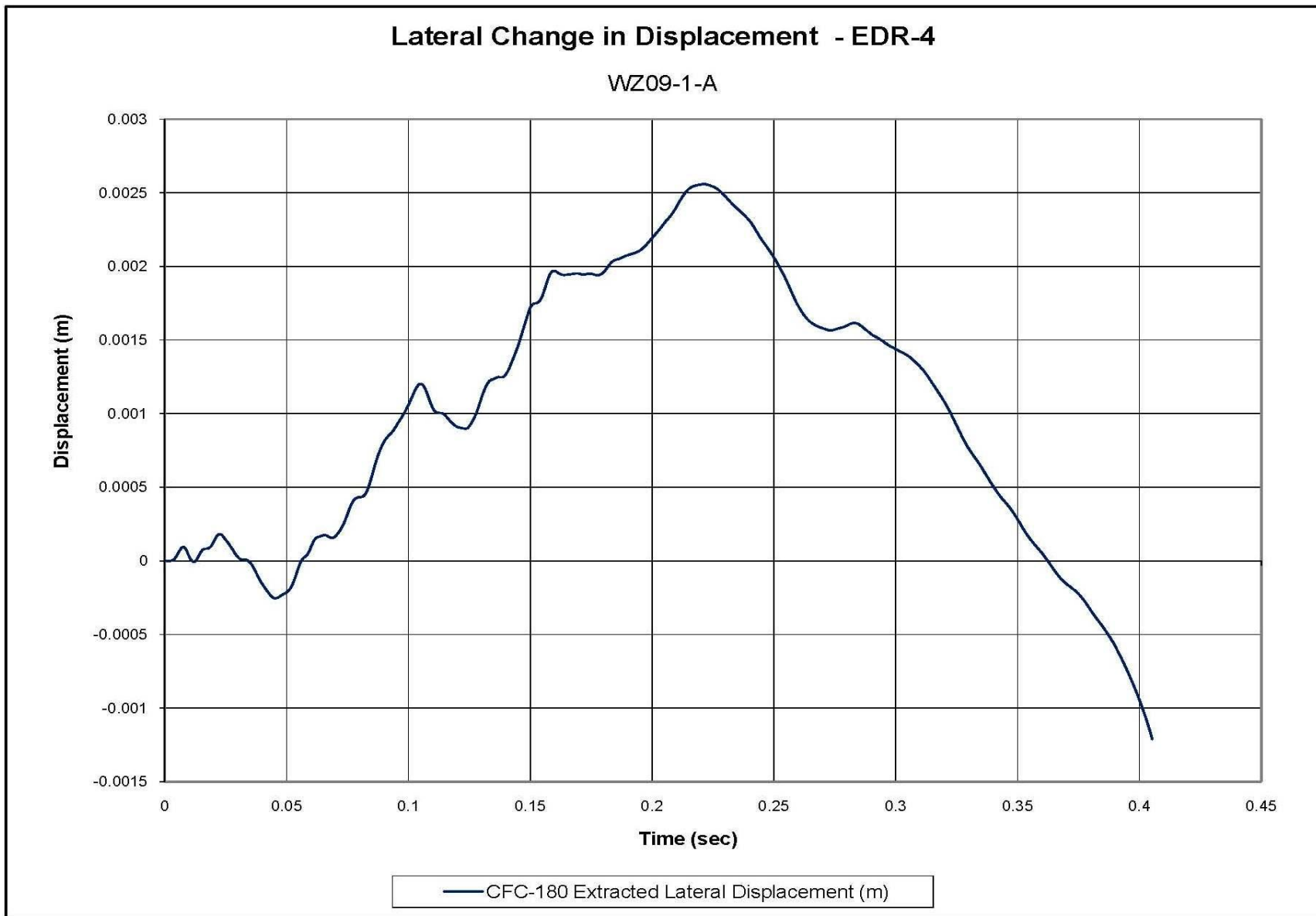

Figure F-6. Lateral Occupant Displacement (EDR-4), Test No. WZ09-1A

300

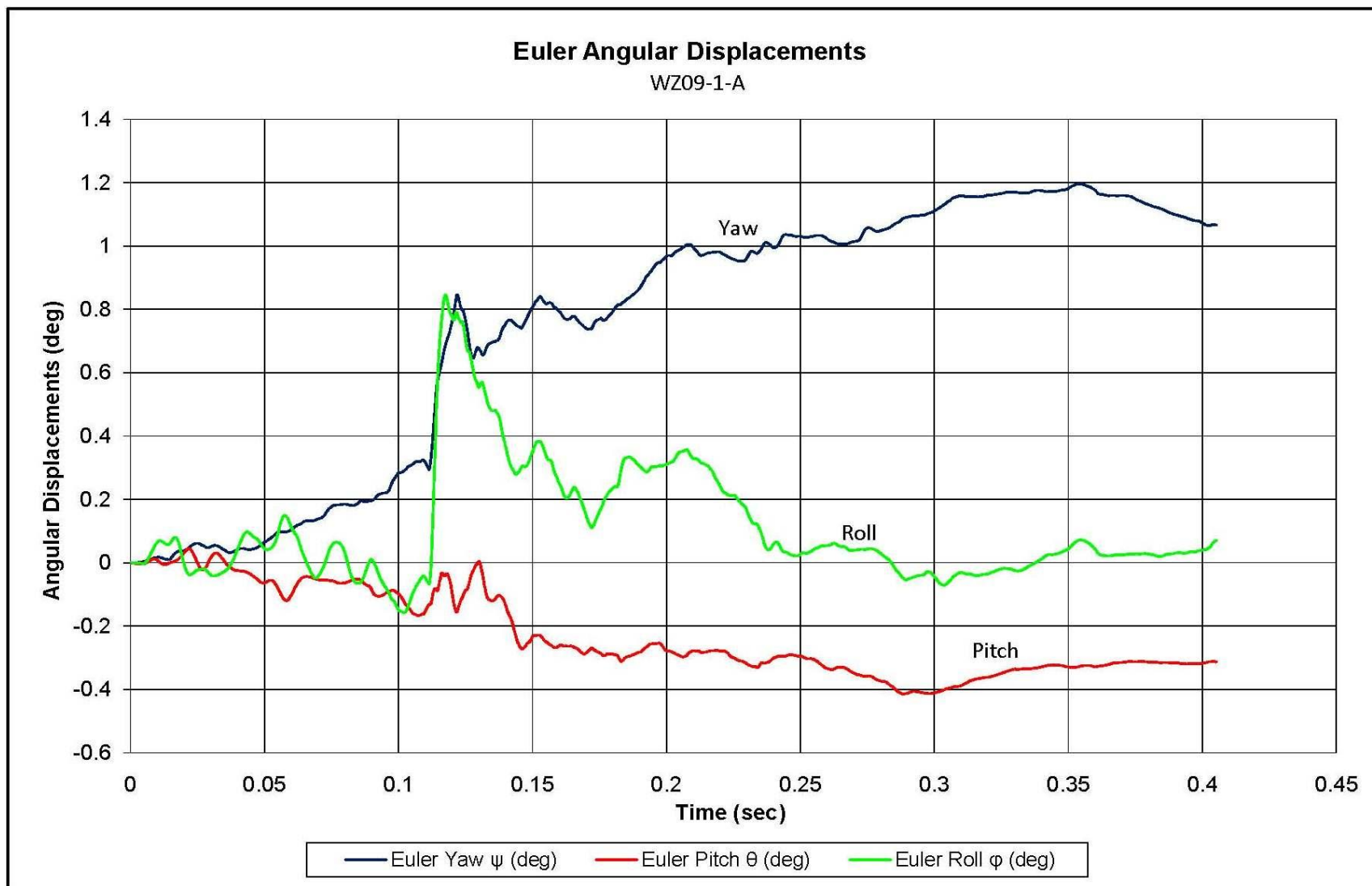

Figure F-7. Vehicle Angular Displacements (EDR-4), Test No. WZ09-1A

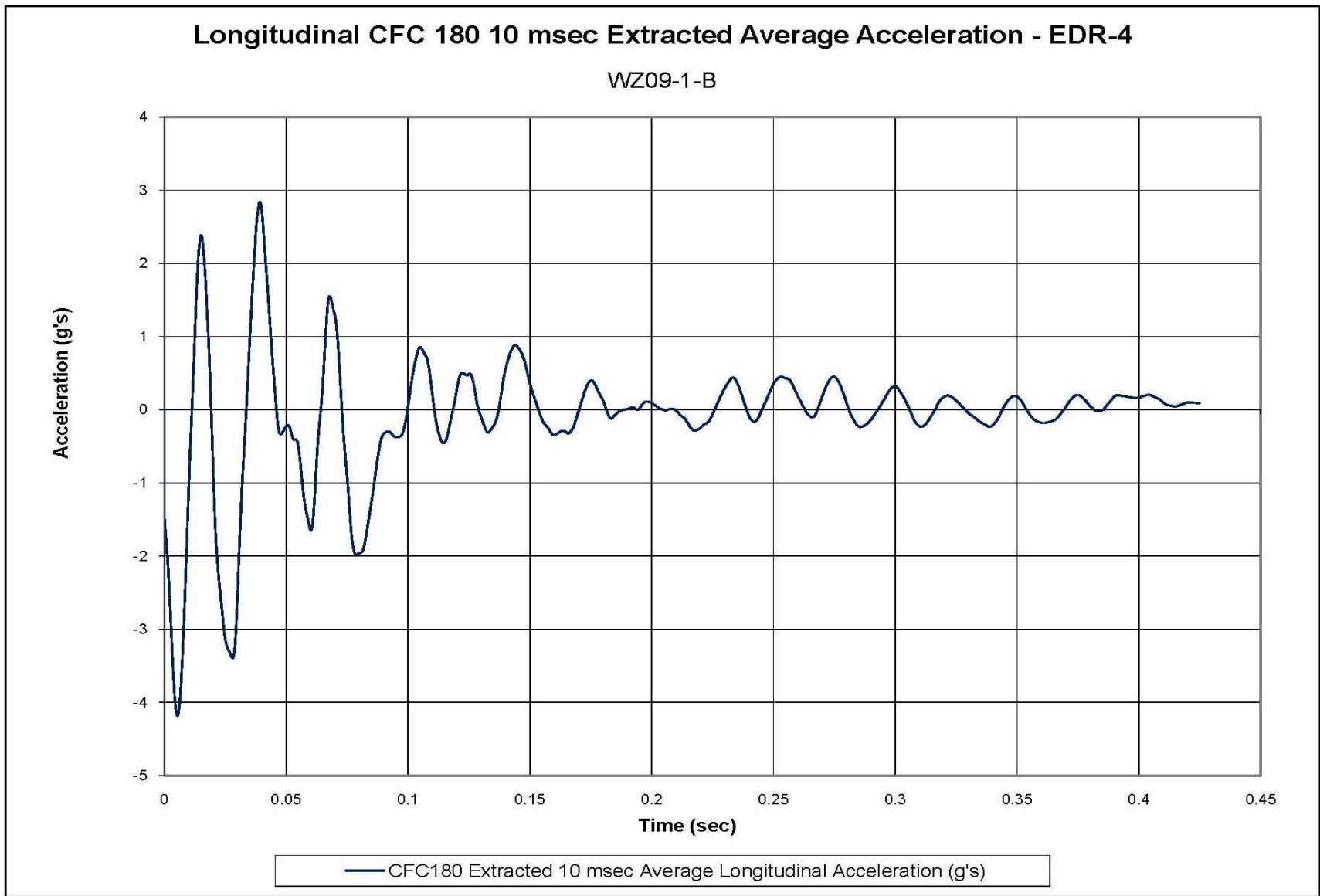

Figure F-8. 10-ms Average Longitudinal Deceleration (EDR-4), Test No. WZ09-1B

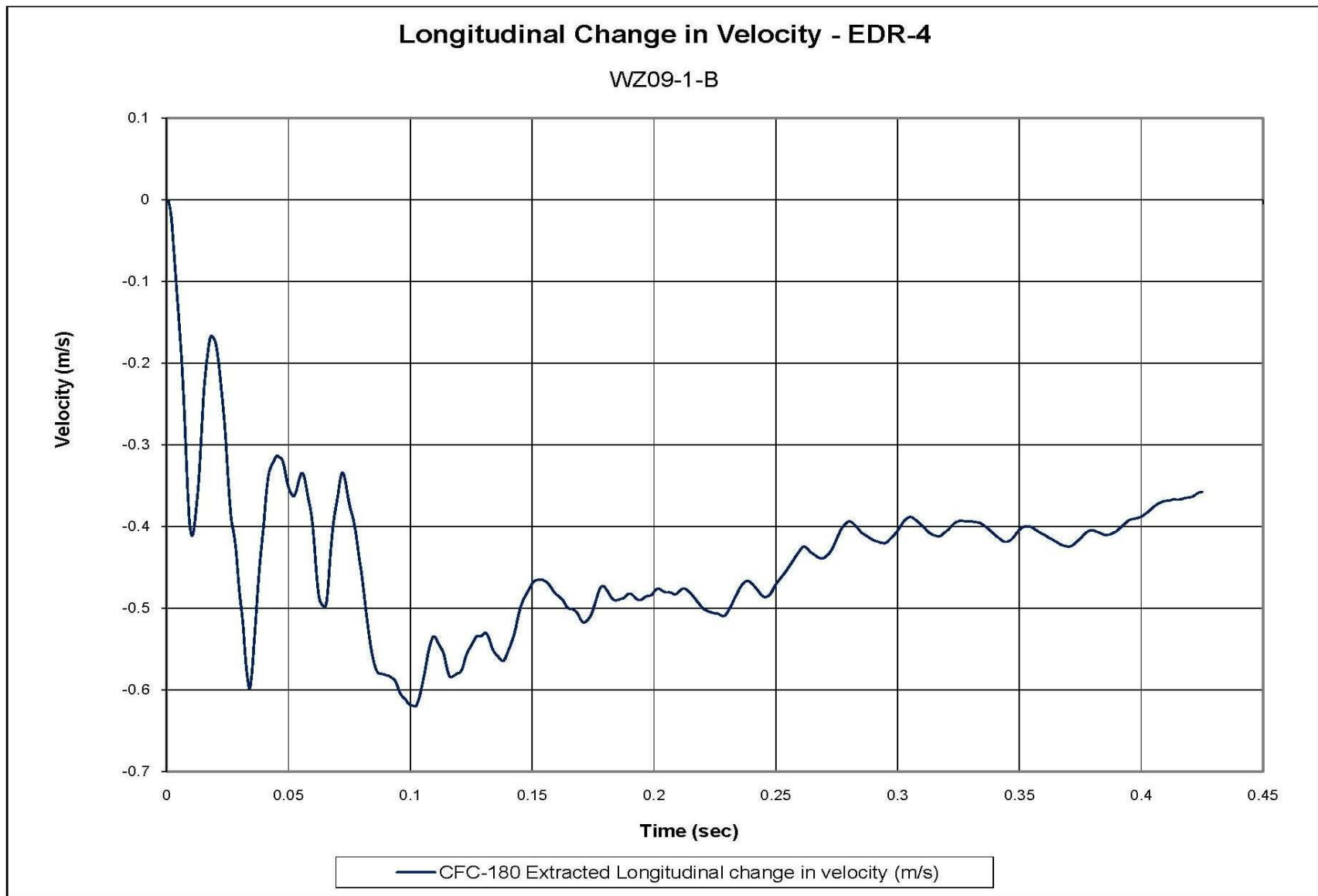

Figure F-9. Longitudinal Occupant Impact Velocity (EDR-4), Test No. WZ09-1B

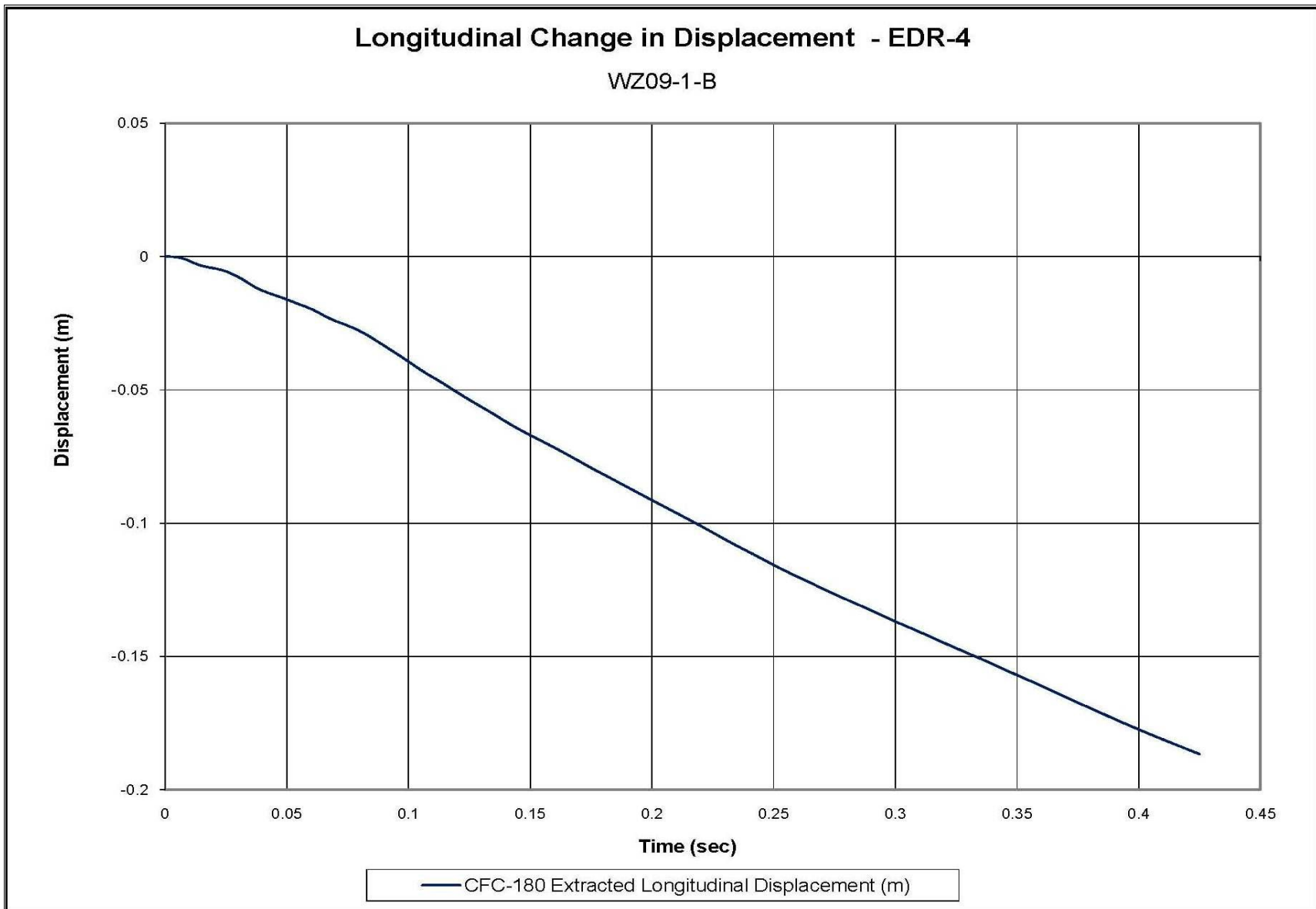

Figure F-10. Longitudinal Occupant Displacement (EDR-4), Test No. WZ09-1B

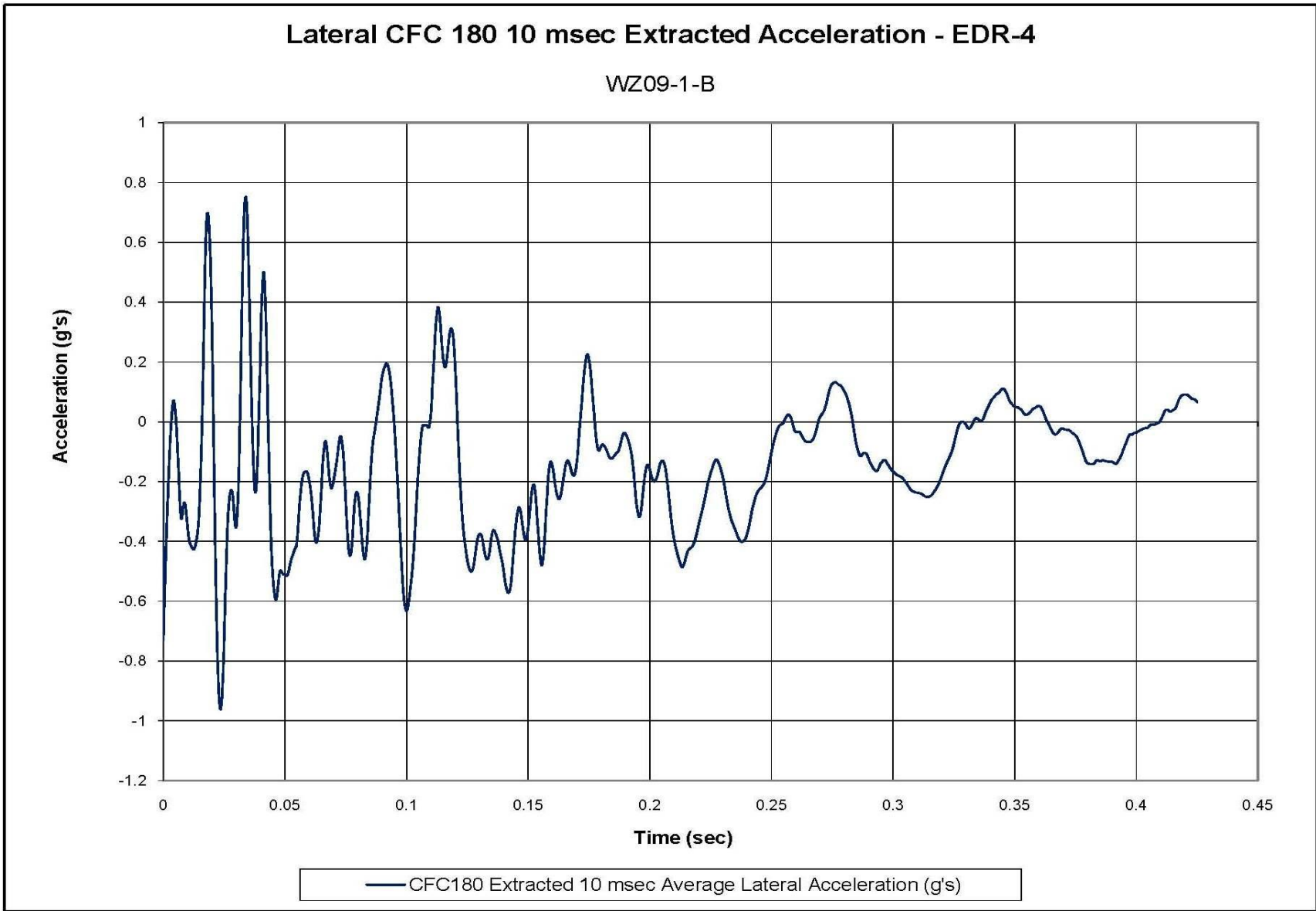

Figure F-11. 10-ms Average Lateral Deceleration (EDR-4), Test No. WZ09-1B

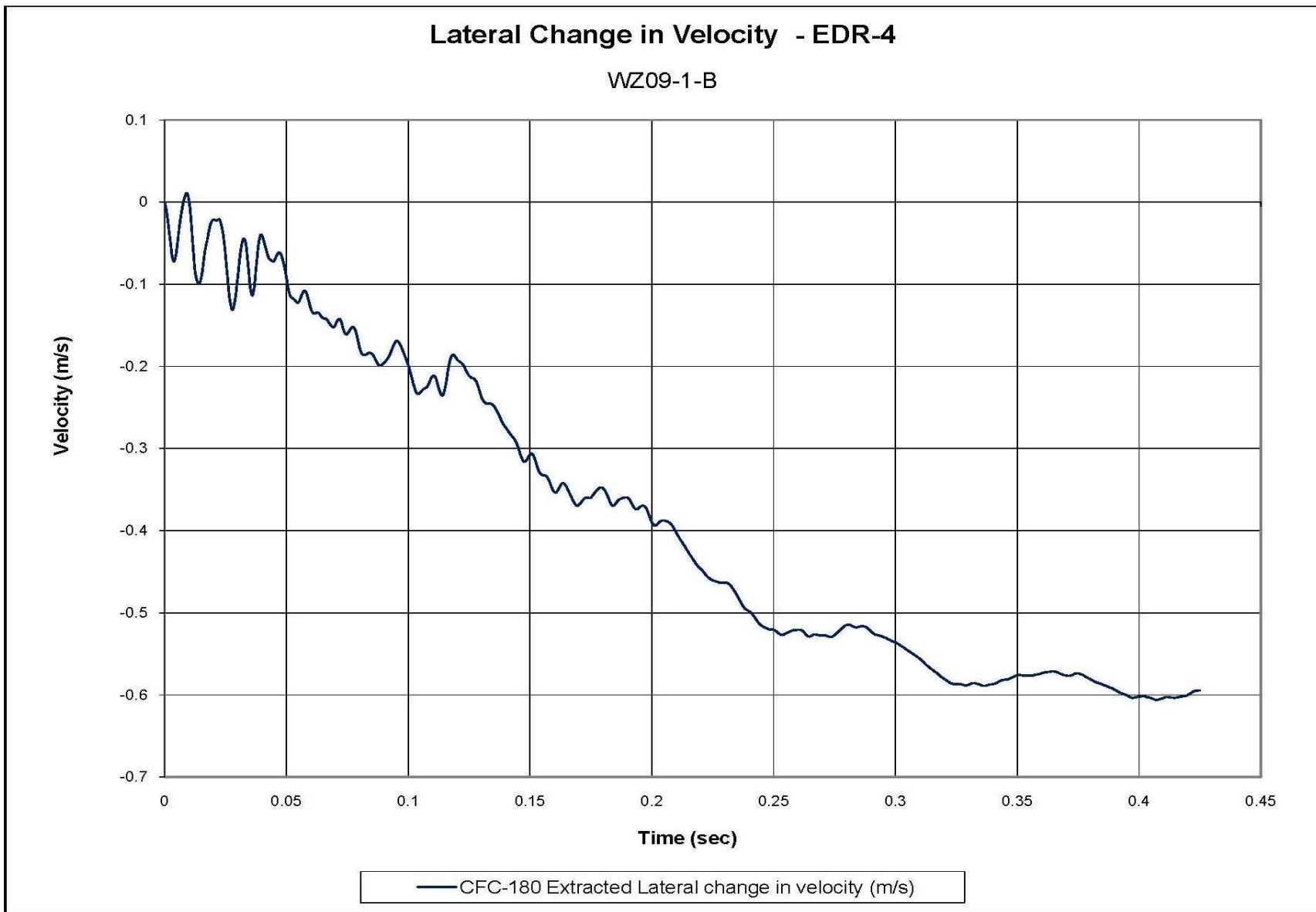

Figure F-12. Lateral Occupant Impact Velocity (EDR-4), Test No. WZ09-1B

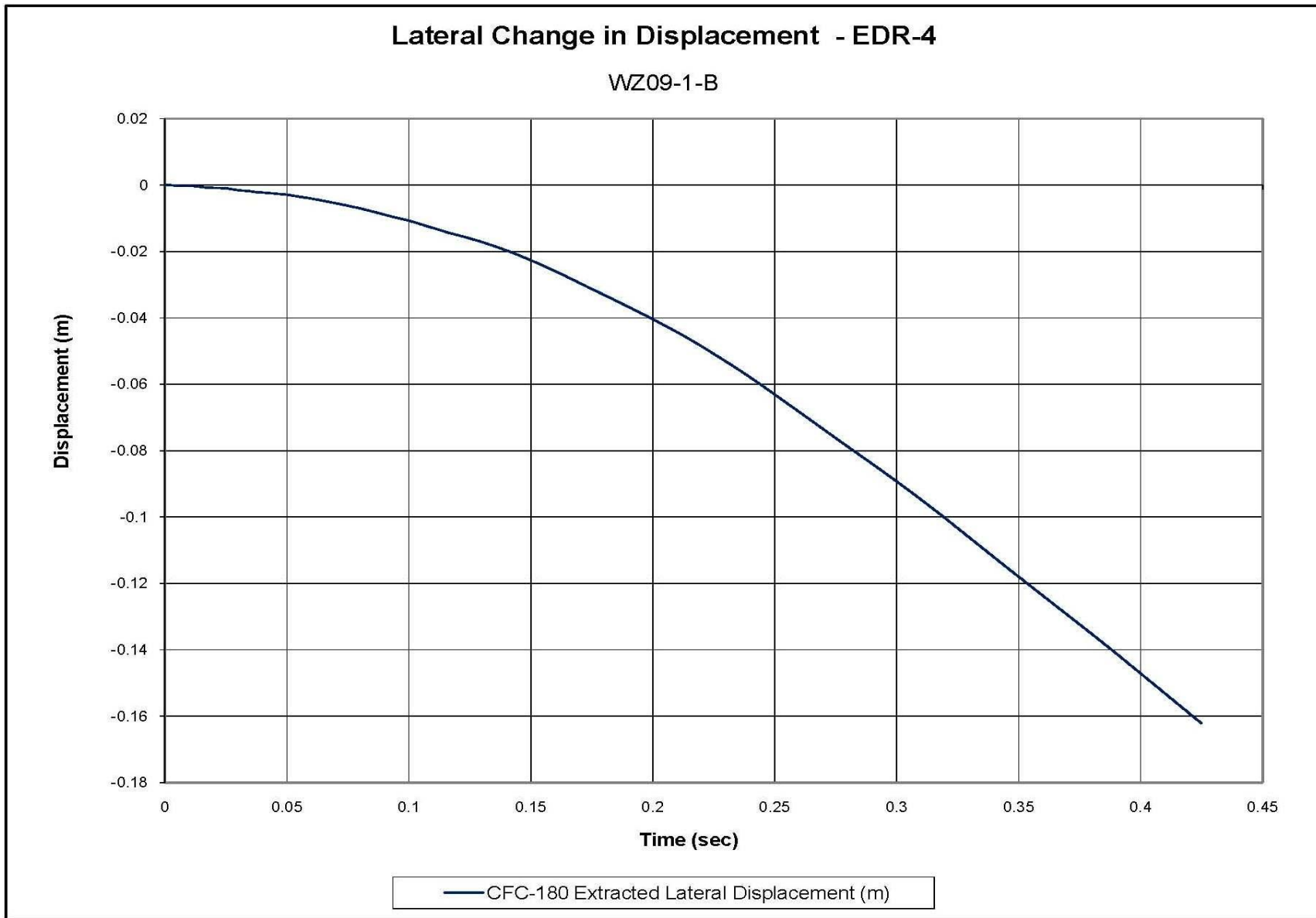

Figure F-13. Lateral Occupant Displacement (EDR-4), Test No. WZ09-1B

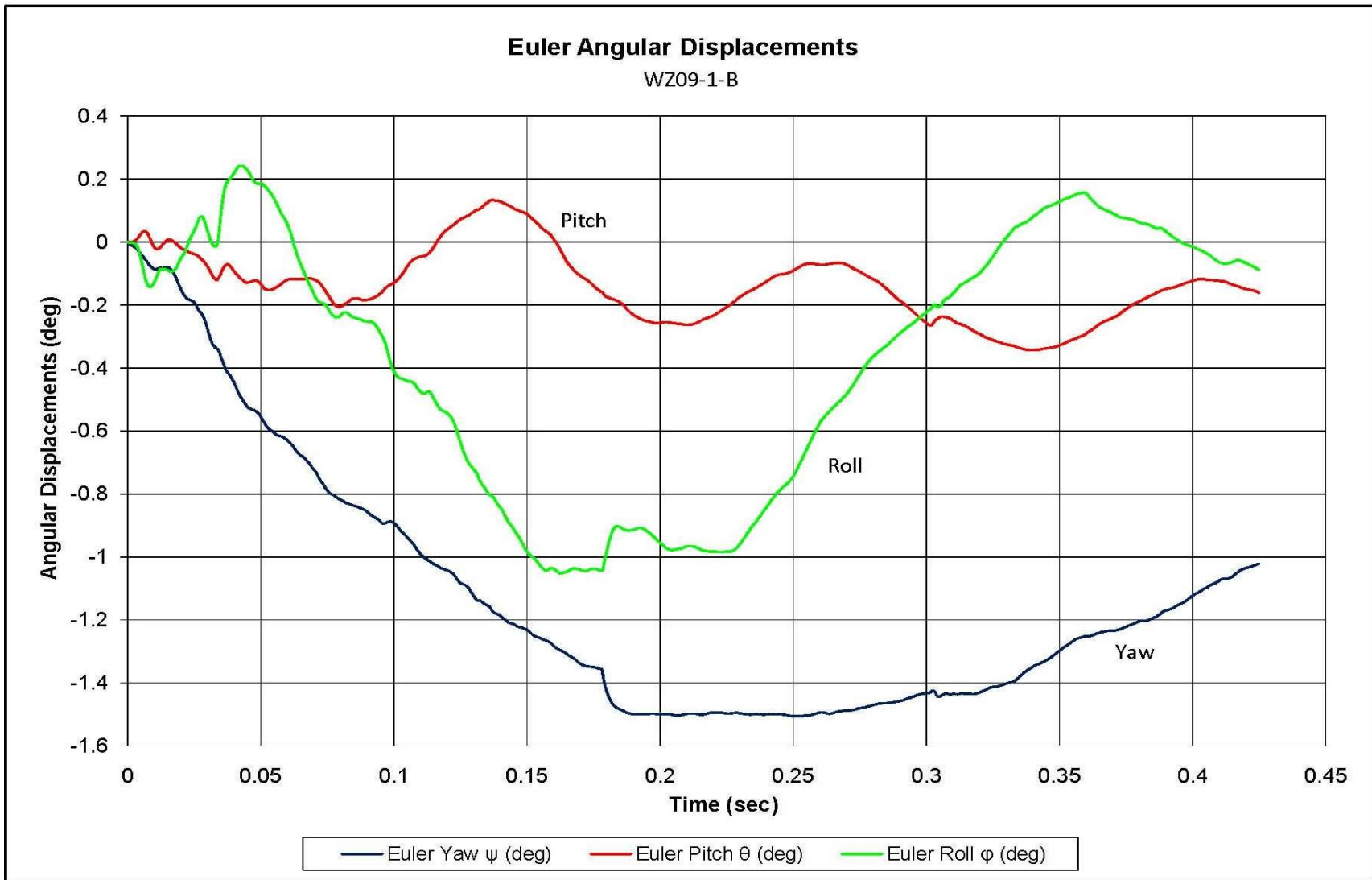

Figure F-14. Vehicle Angular Displacements (EDR-4), Test No. WZ09-1B

Appendix G. Accelerometer and Rate Transducer Plots, Test No. WZ09-2

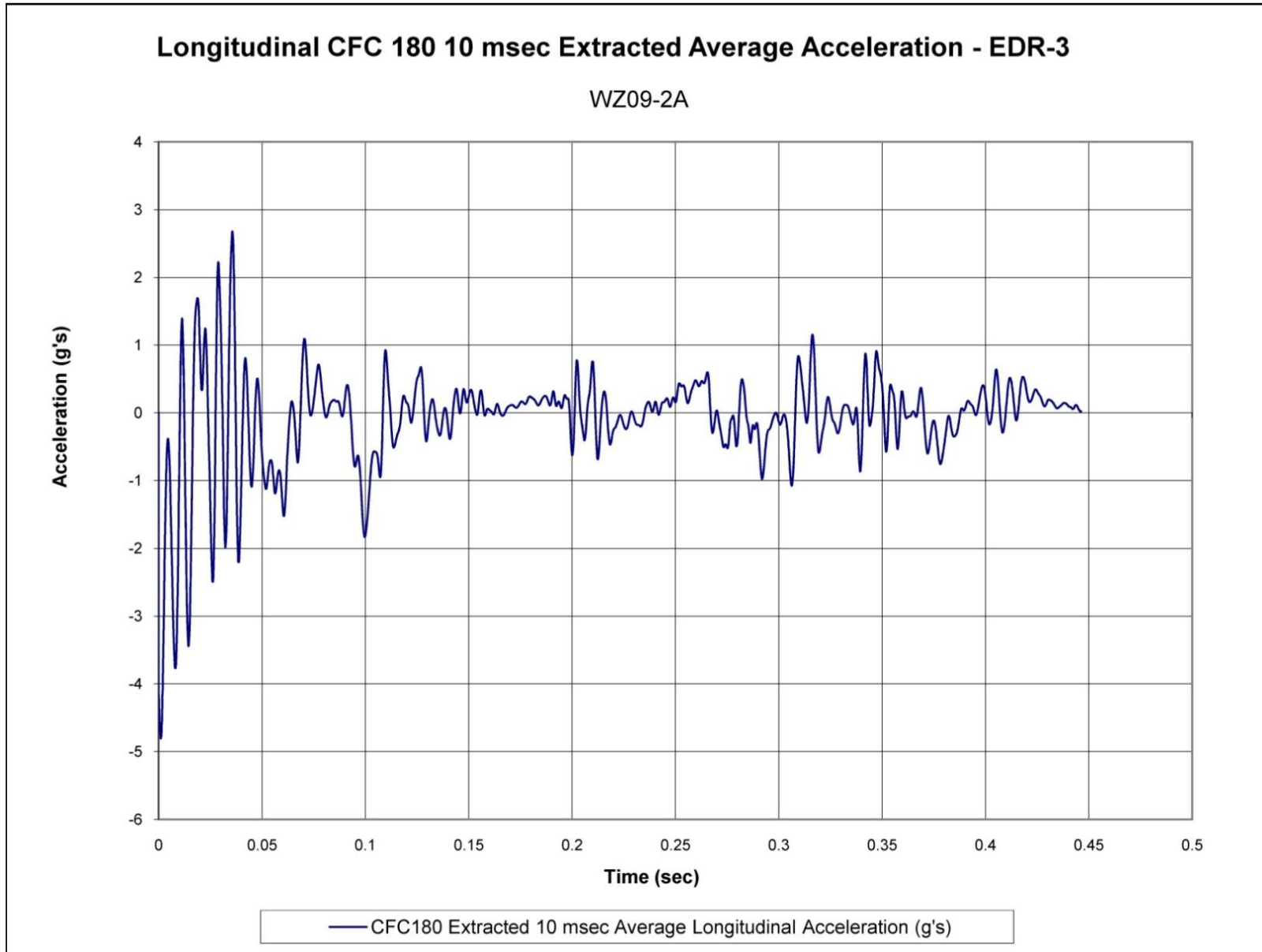

Figure G-1. 10-ms Average Longitudinal Deceleration (EDR-3), Test No. WZ09-2A

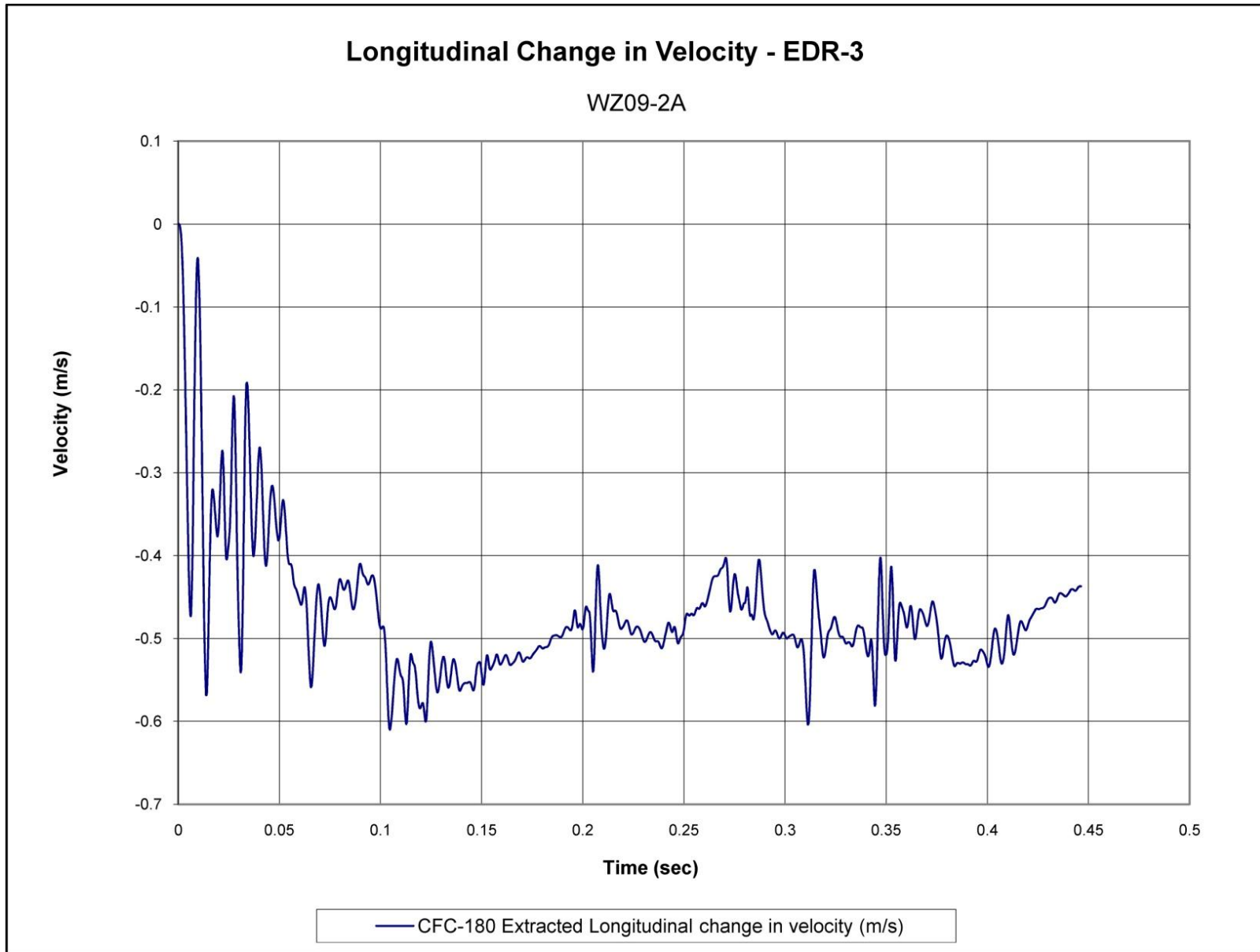

Figure G-2. Longitudinal Occupant Impact Velocity (EDR-3), Test No. WZ09-2A

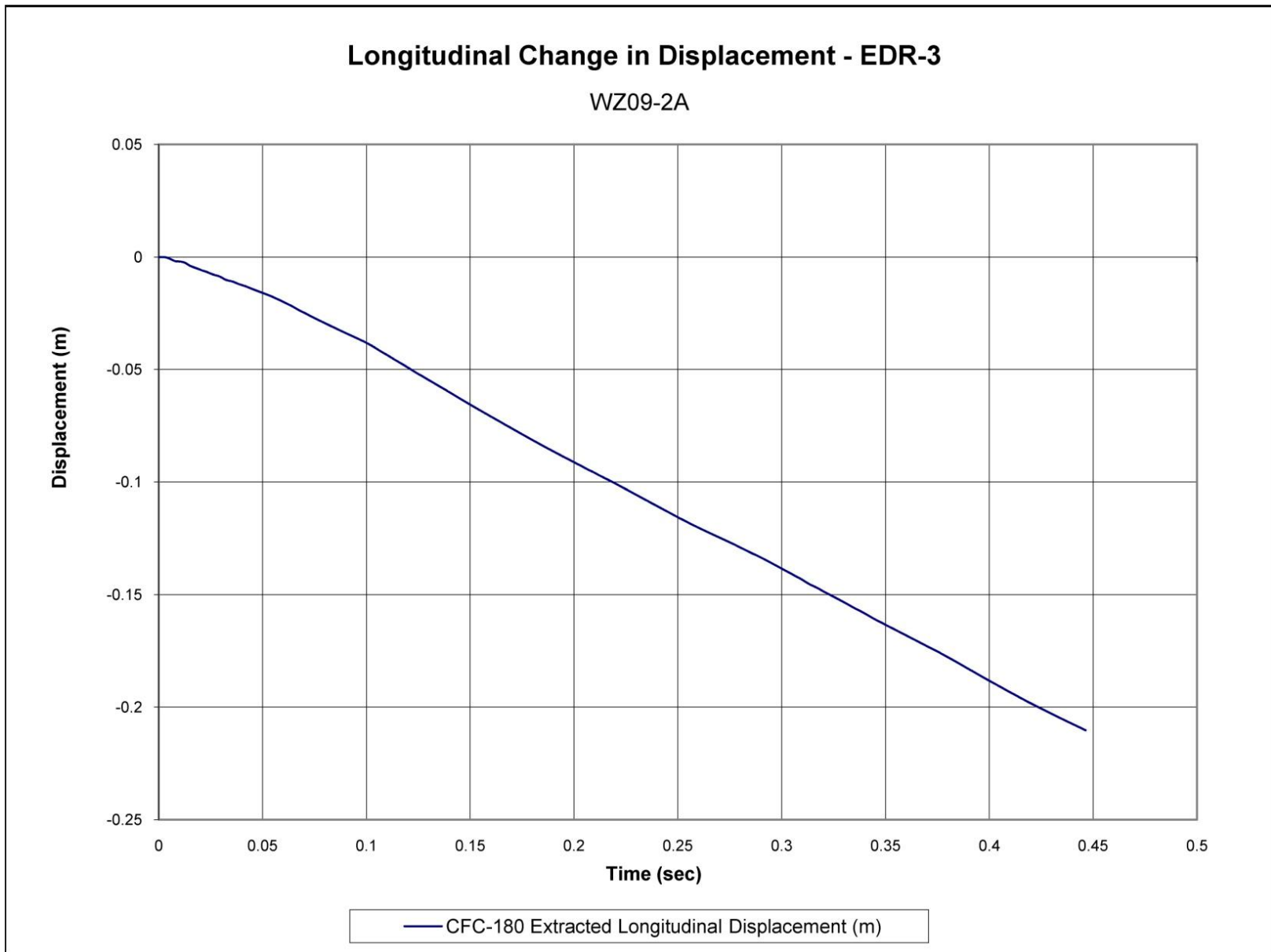

Figure G-3. Longitudinal Occupant Displacement (EDR-3), Test No. WZ09-2A

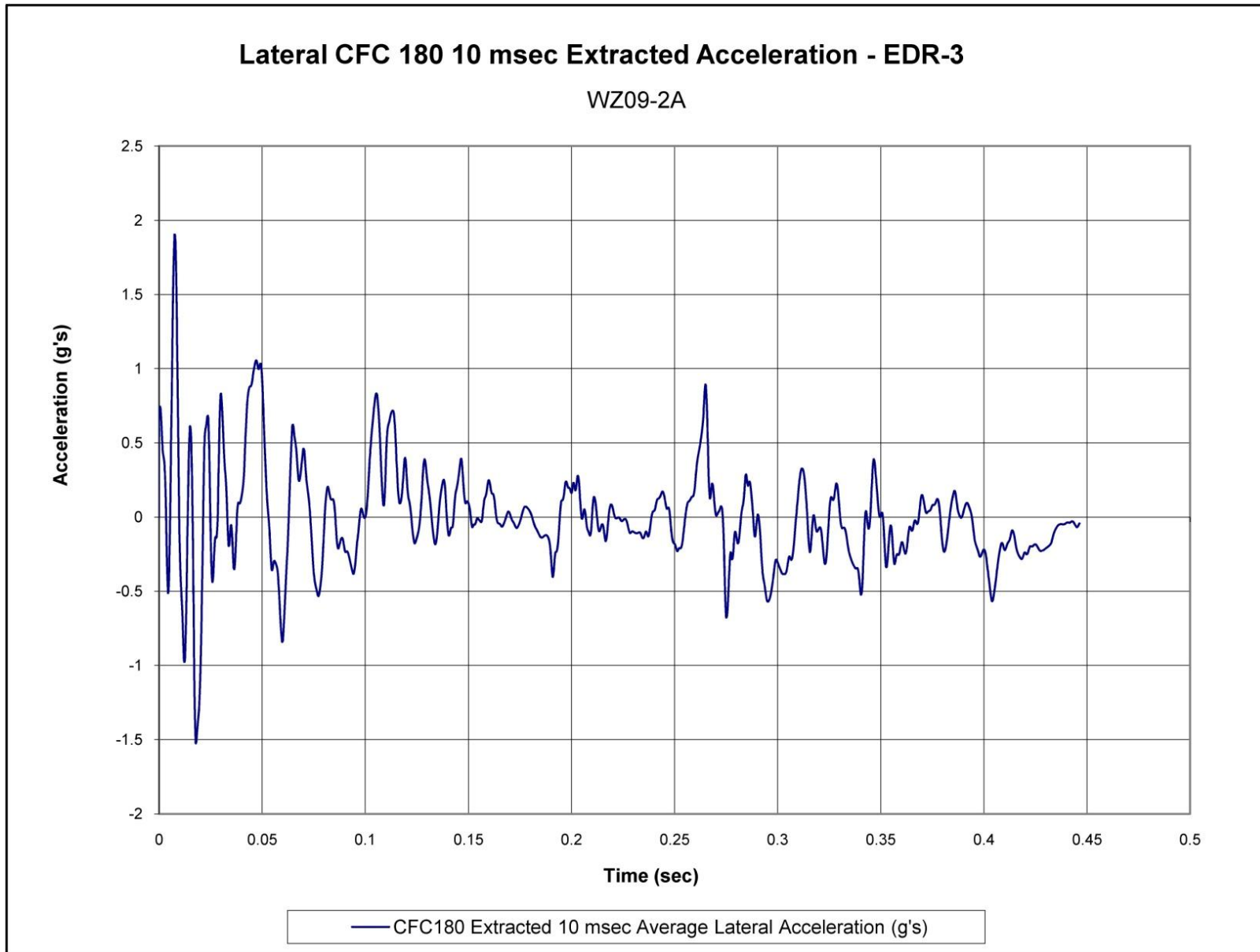

Figure G-4. 10-ms Average Lateral Deceleration (EDR-3), Test No. WZ09-2A

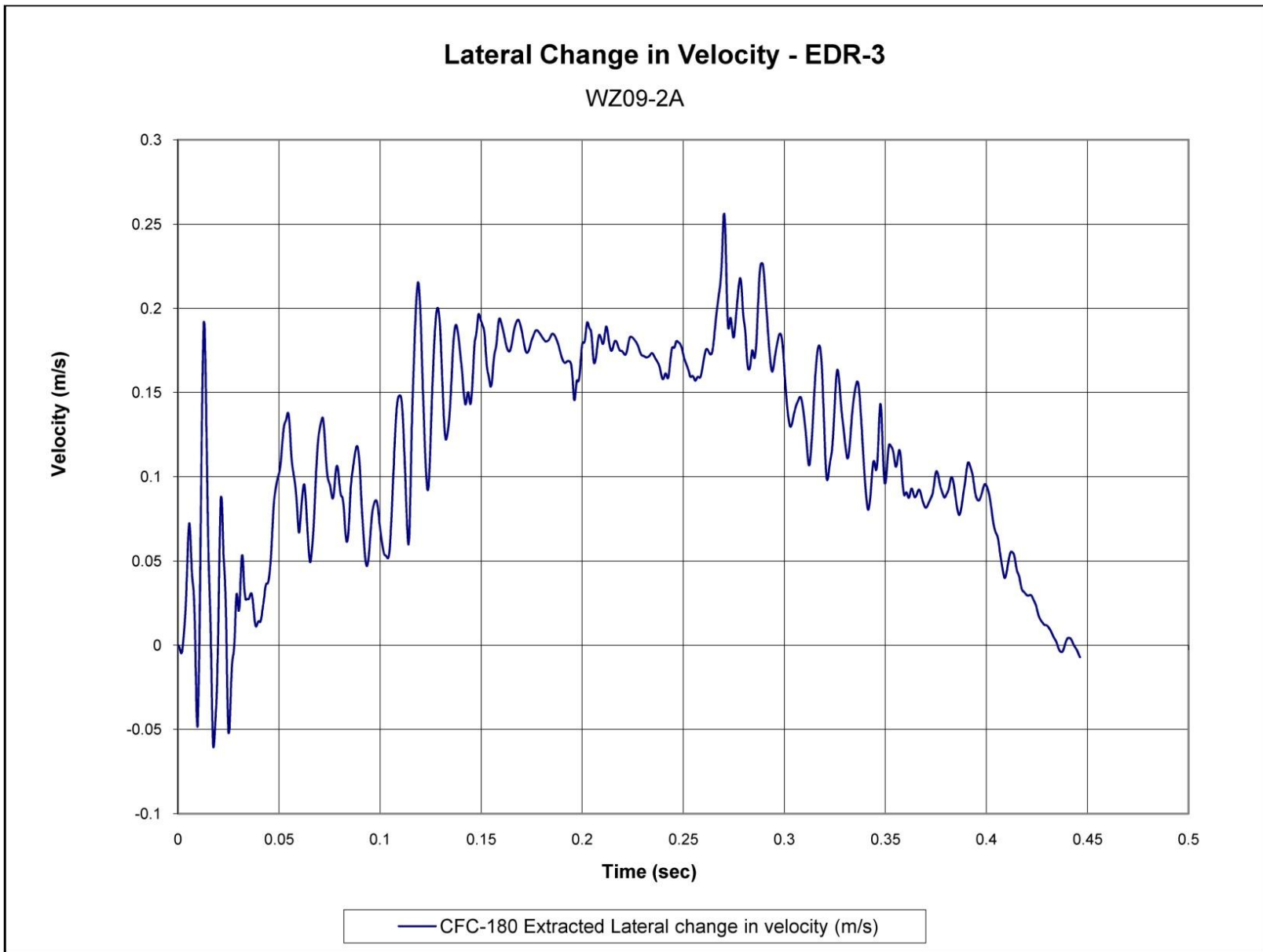

Figure G-5. Lateral Occupant Impact Velocity (EDR-3), Test No. WZ09-2A

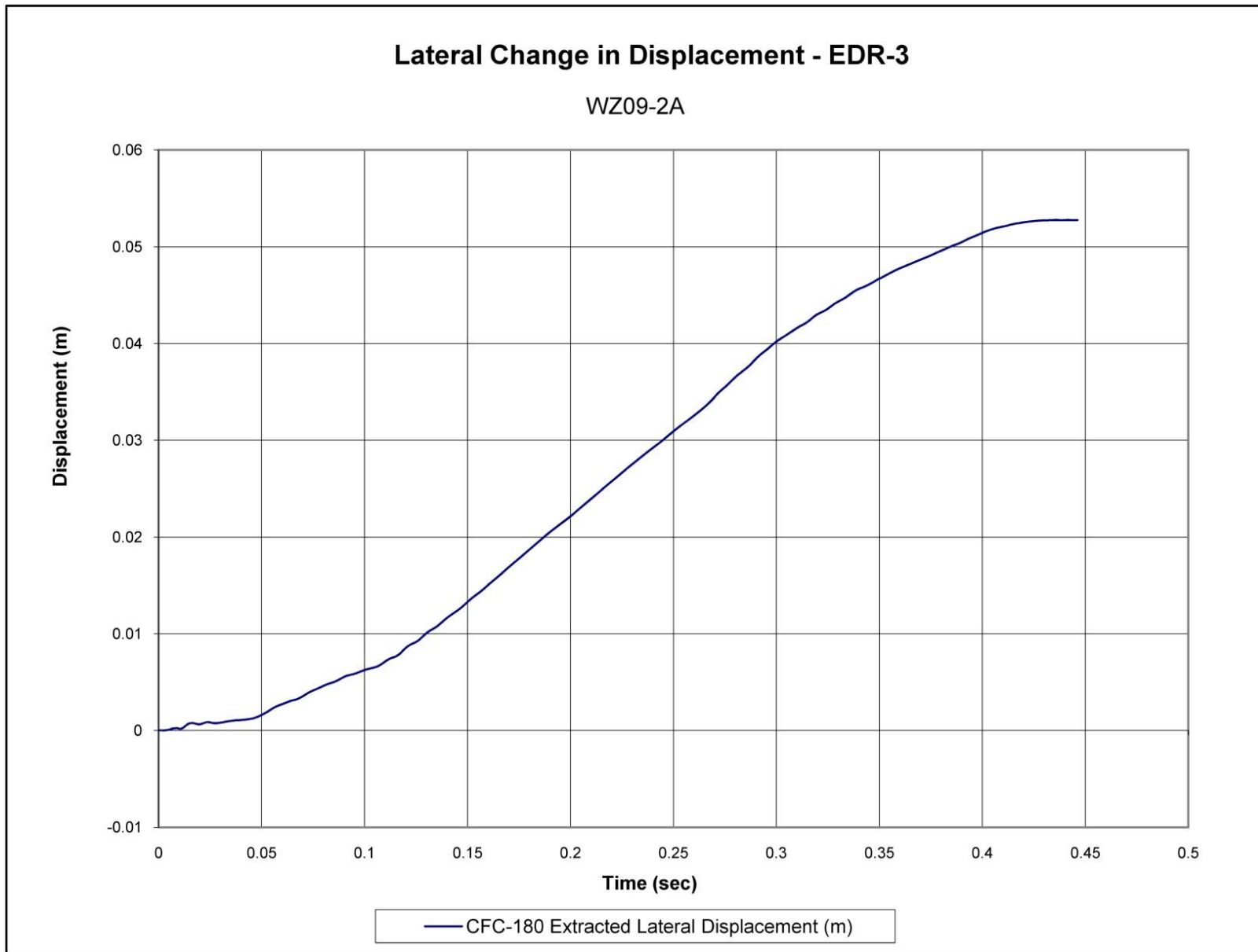

Figure G-6. Lateral Occupant Displacement (EDR-3), Test No. WZ09-2A

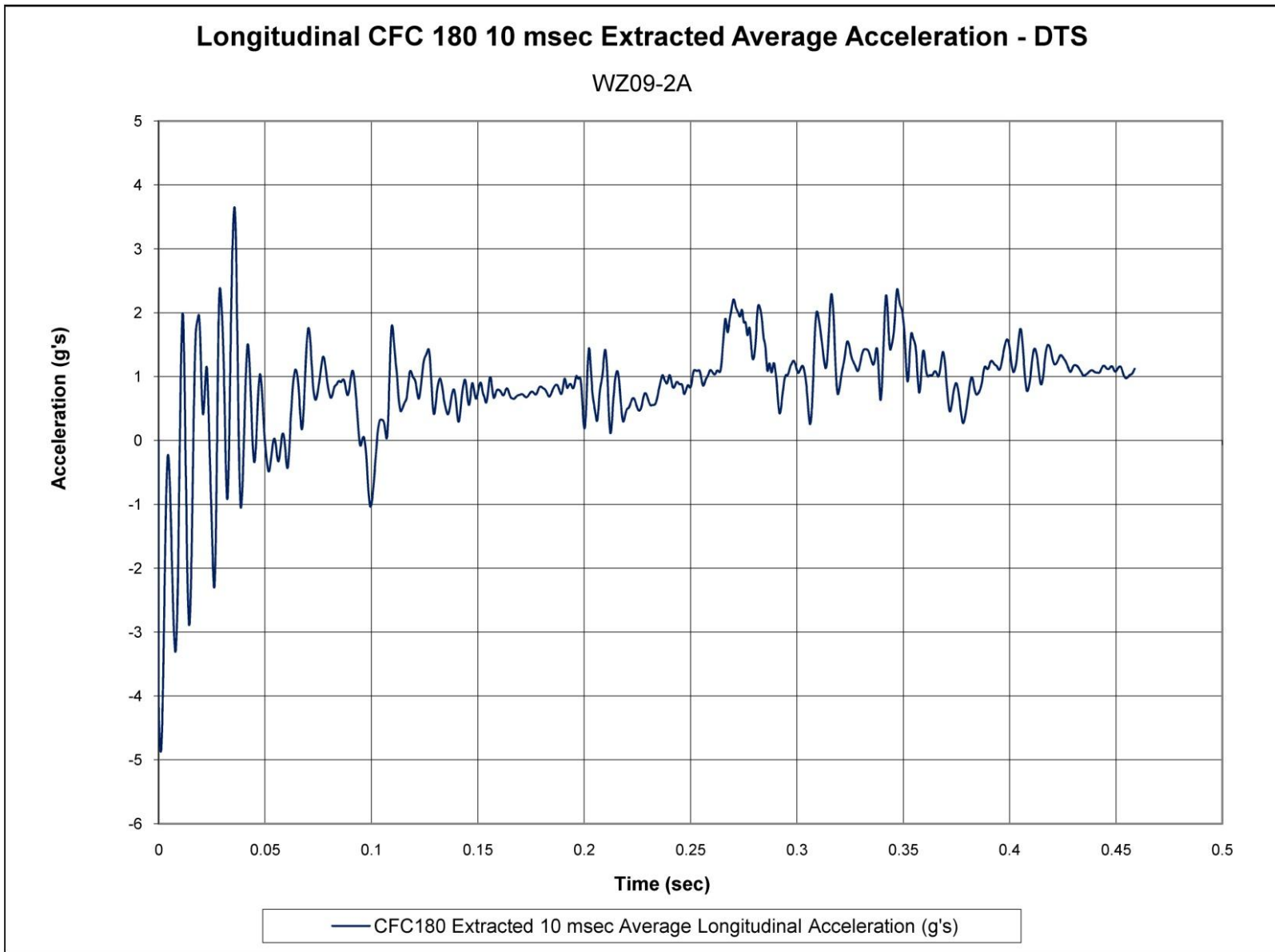

Figure G-7. 10-ms Average Longitudinal Deceleration (DTS), Test No. WZ09-2A

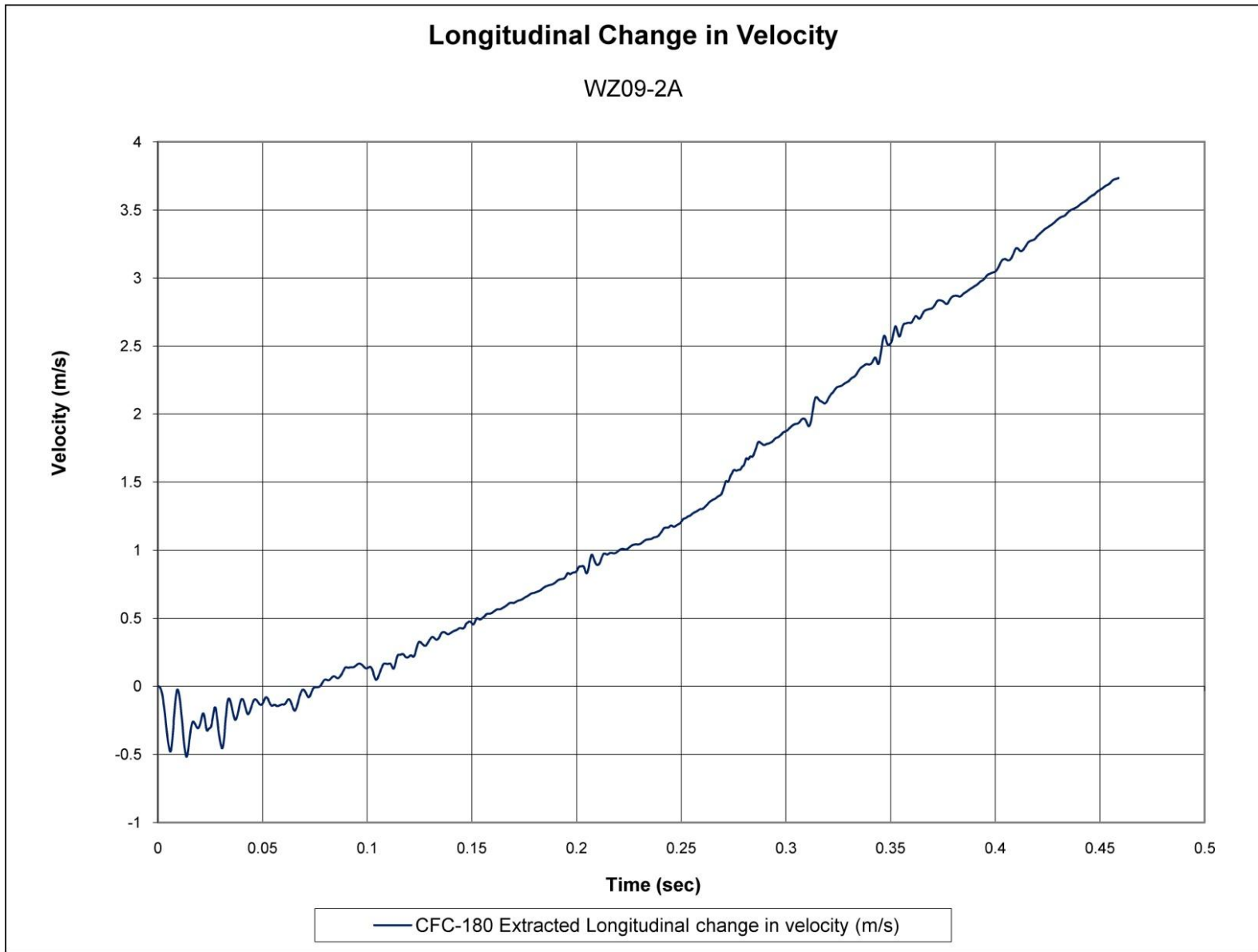

Figure G-8. Longitudinal Occupant Impact Velocity (DTS), Test No. WZ09-2A

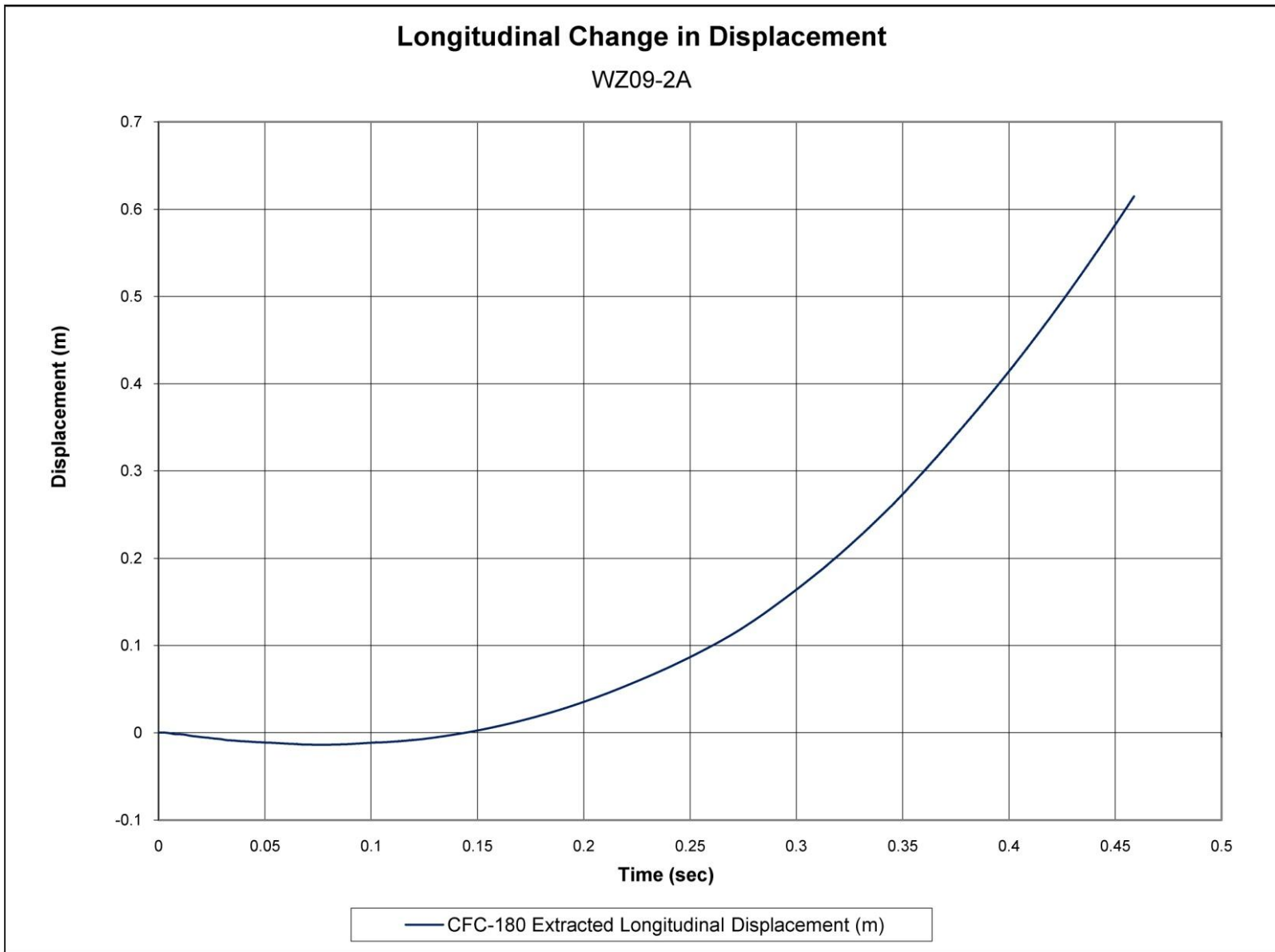

Figure G-9. Longitudinal Occupant Displacement (DTS), Test No. WZ09-2A

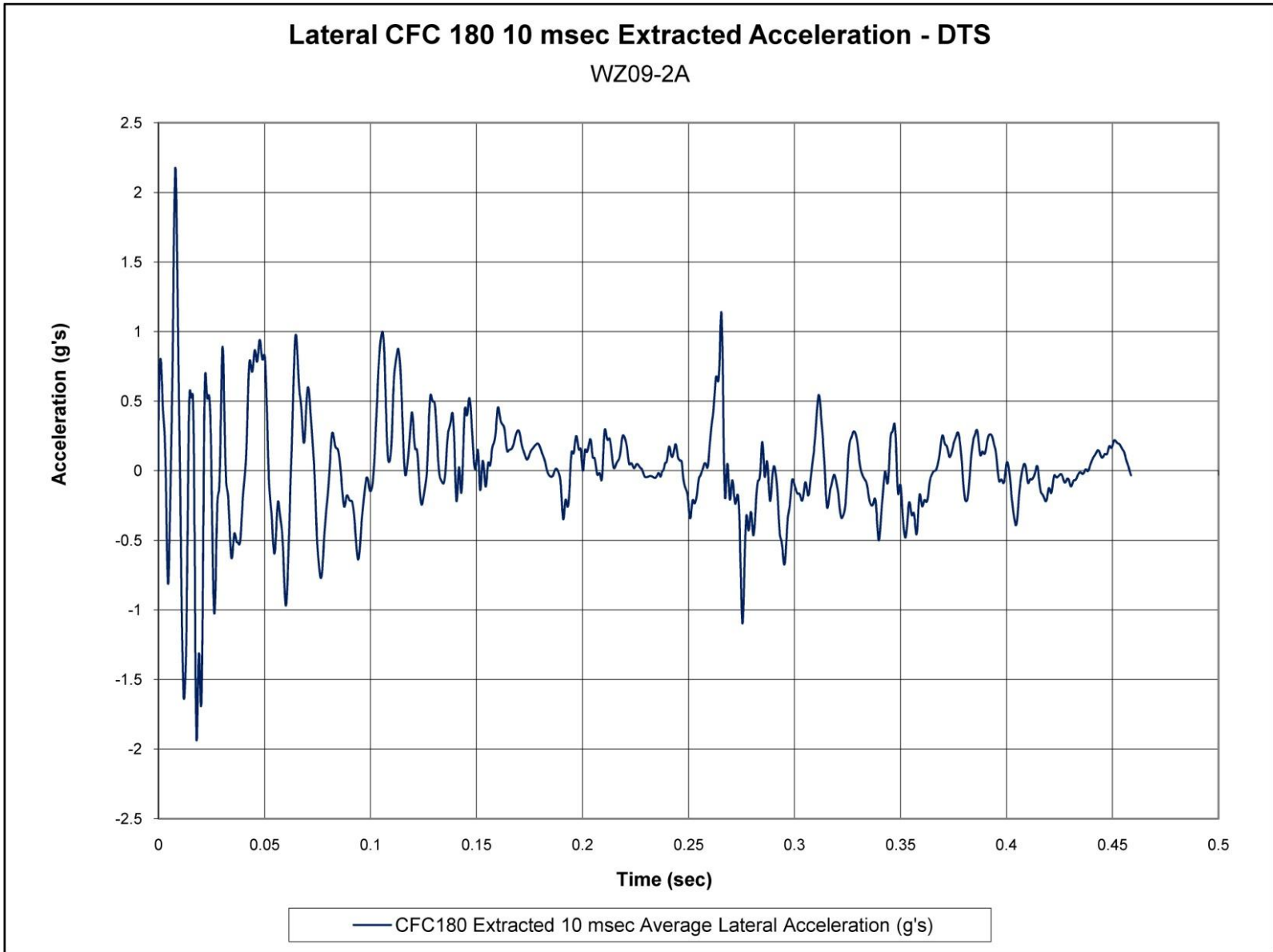

Figure G-10. 10-ms Average Lateral Deceleration (DTS), Test No. WZ09-2A

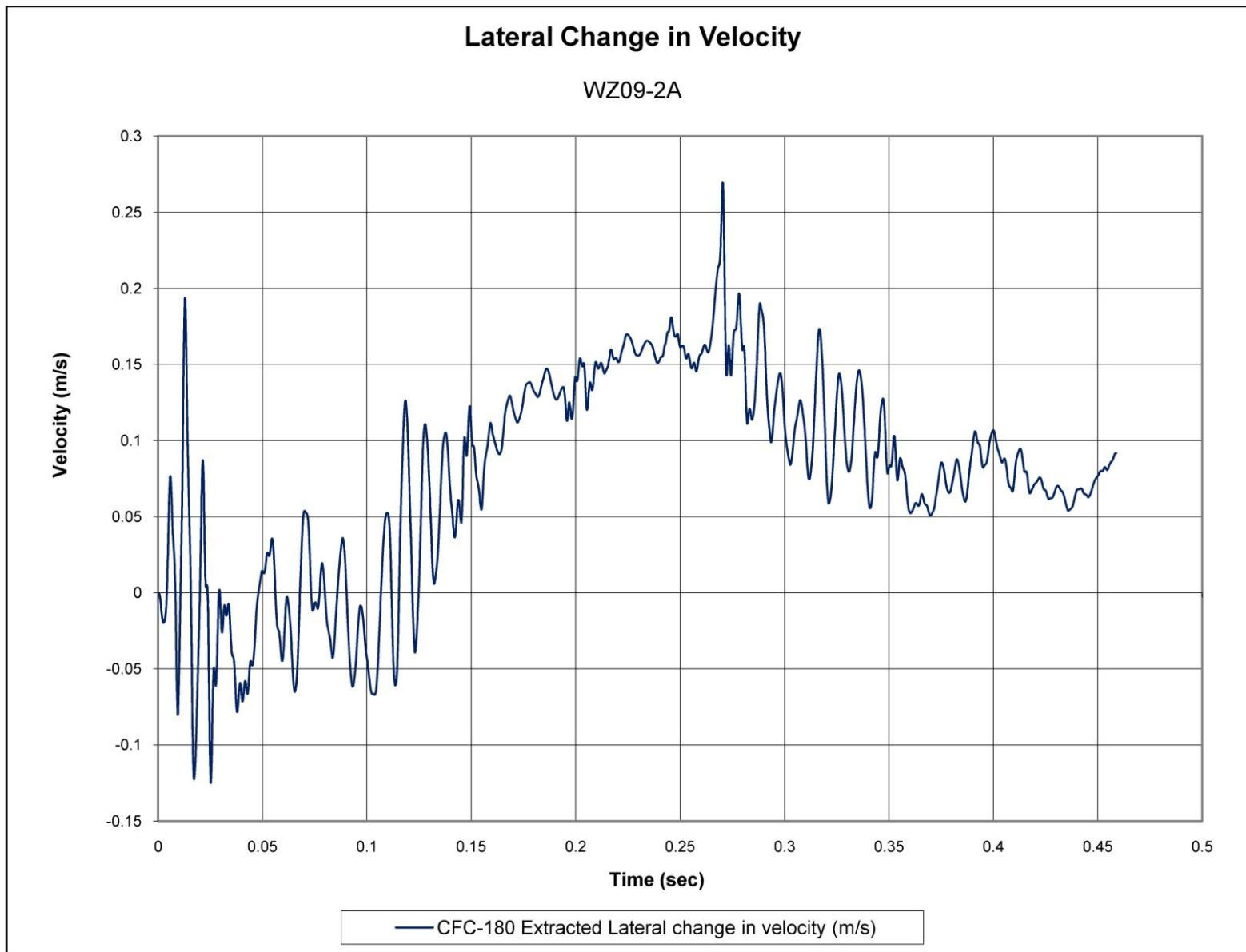

Figure G-11. Lateral Occupant Impact Velocity (DTS), Test No. WZ09-2A

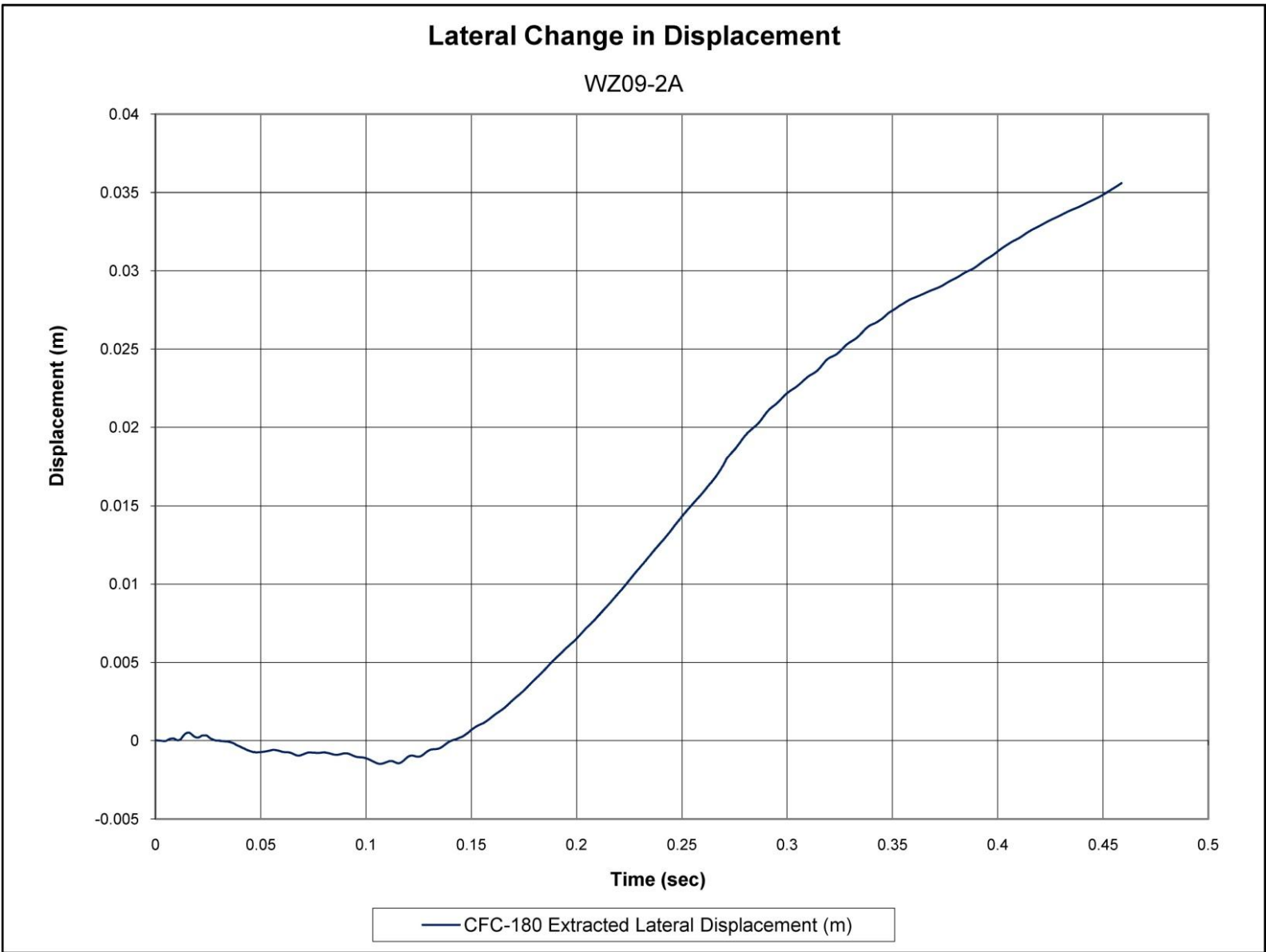

Figure G-12. Lateral Occupant Displacement (DTS), Test No. WZ09-2A

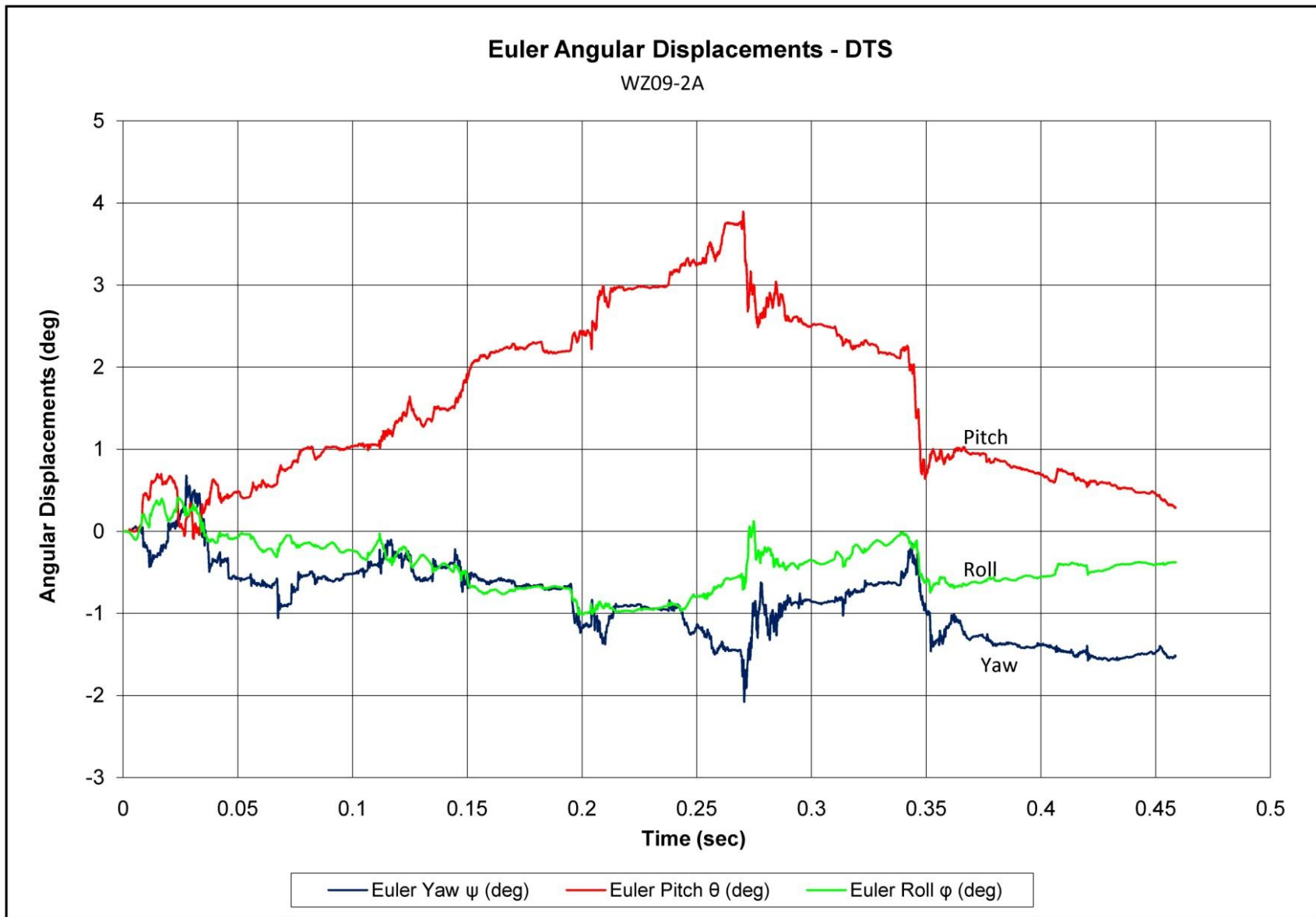

Figure G-13. Vehicle Angular Displacements (DTS), Test No. WZ09-2A

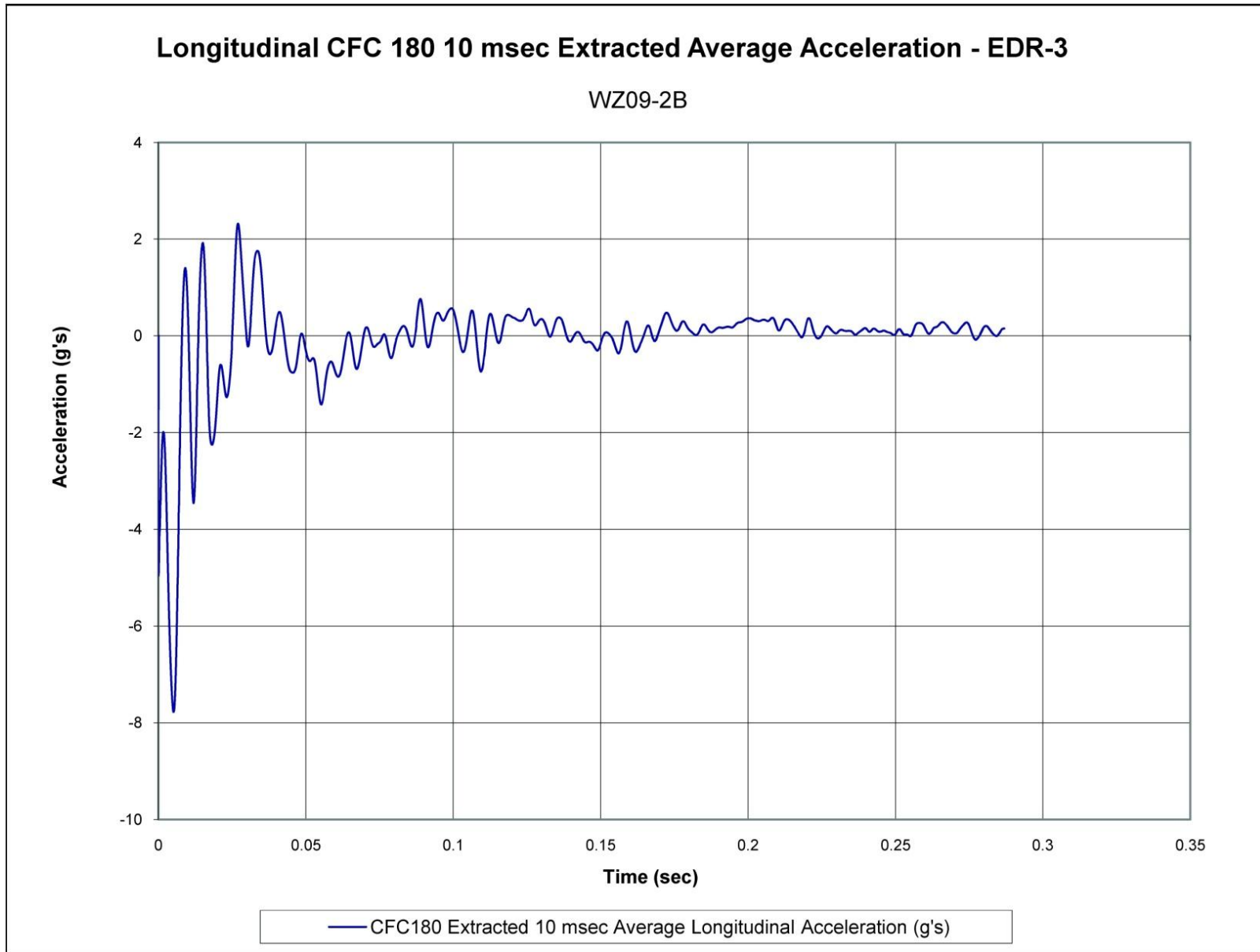

Figure G-14. 10-ms Average Longitudinal Deceleration (EDR-3), Test No. WZ09-2B

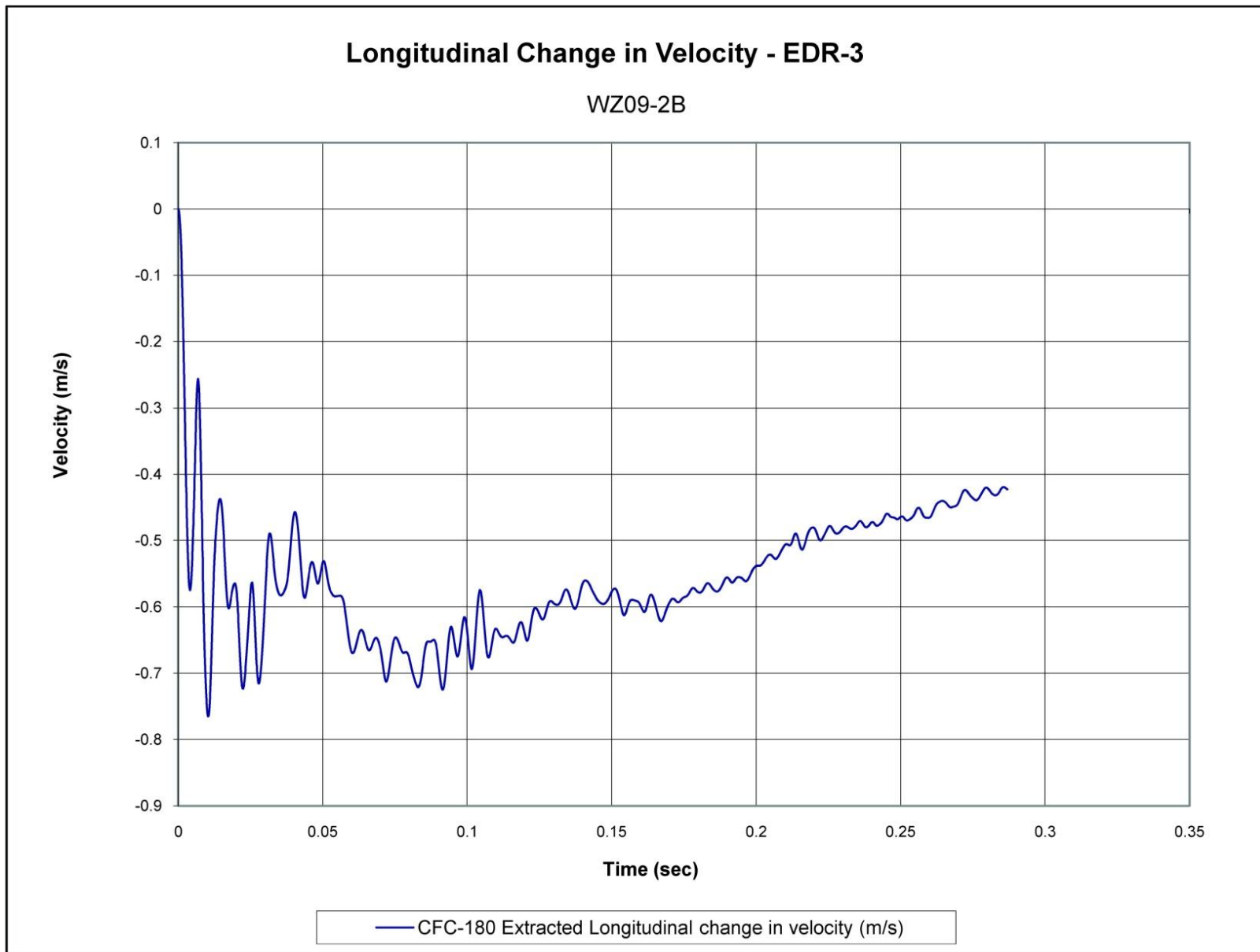

Figure G-15. Longitudinal Occupant Impact Velocity (EDR-3), Test No. WZ09-2B

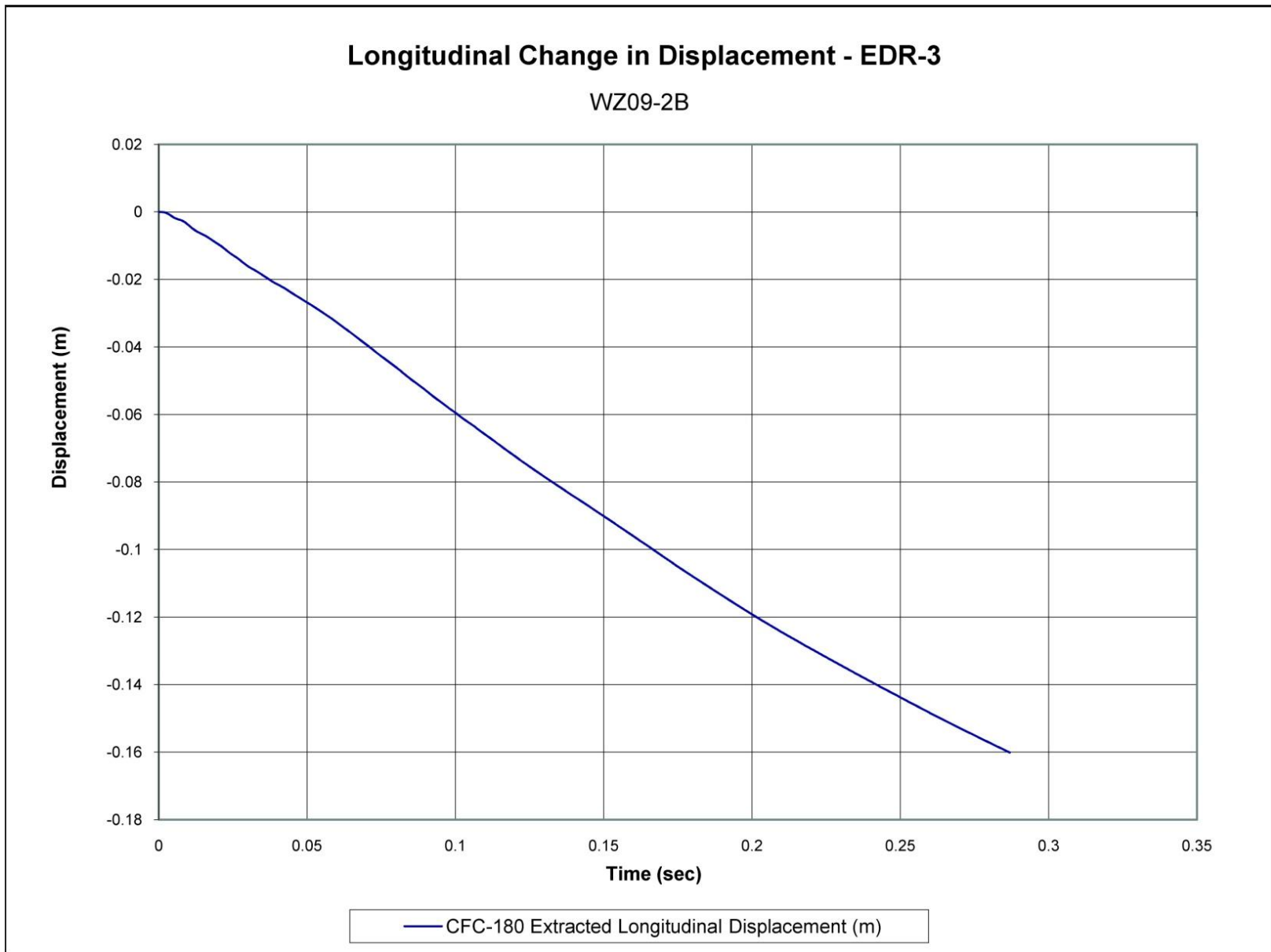

Figure G-16. Longitudinal Occupant Displacement (EDR-3), Test No. WZ09-2B

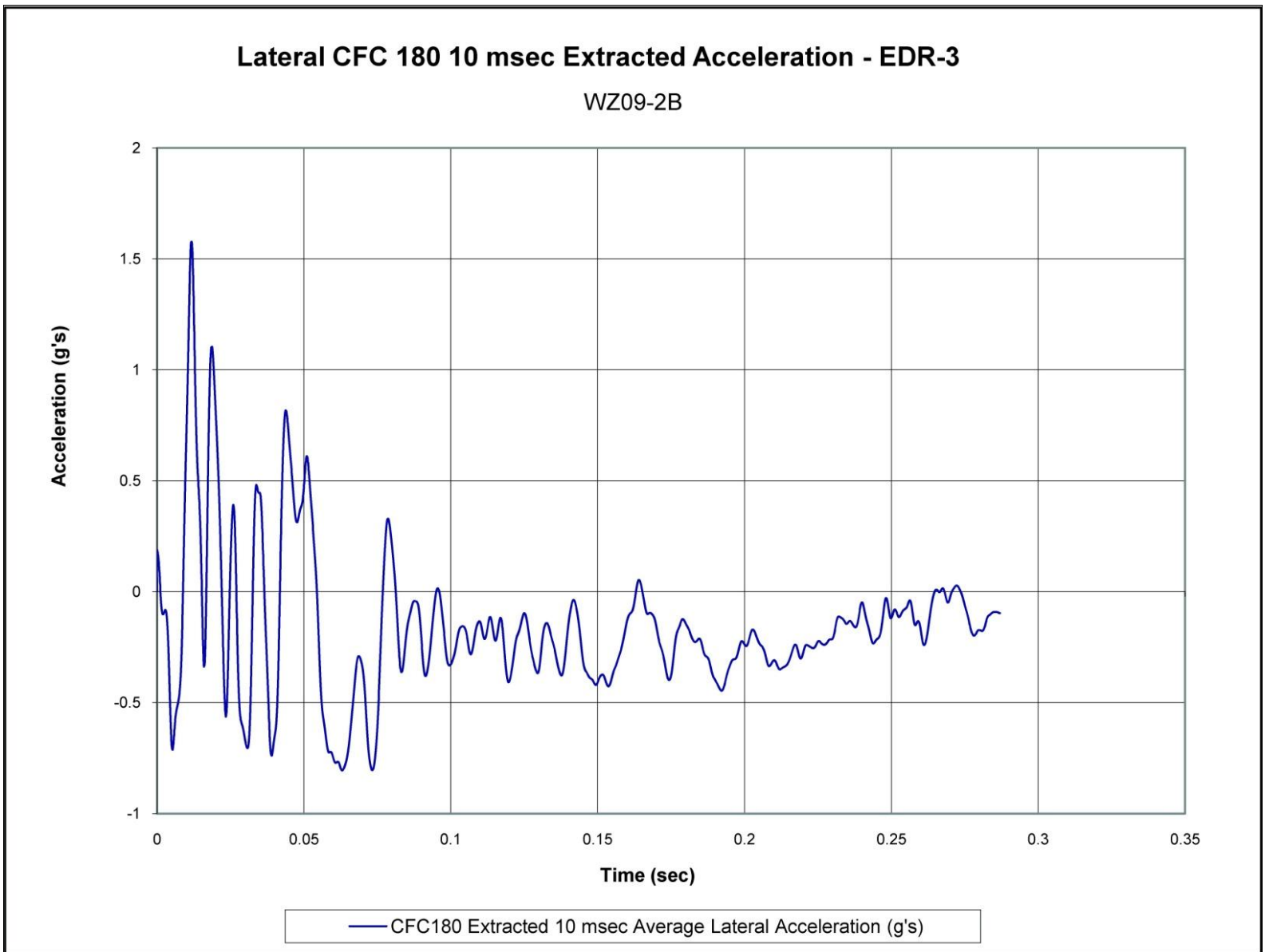

Figure G-17. 10-ms Average Lateral Deceleration (EDR-3), Test No. WZ09-2B

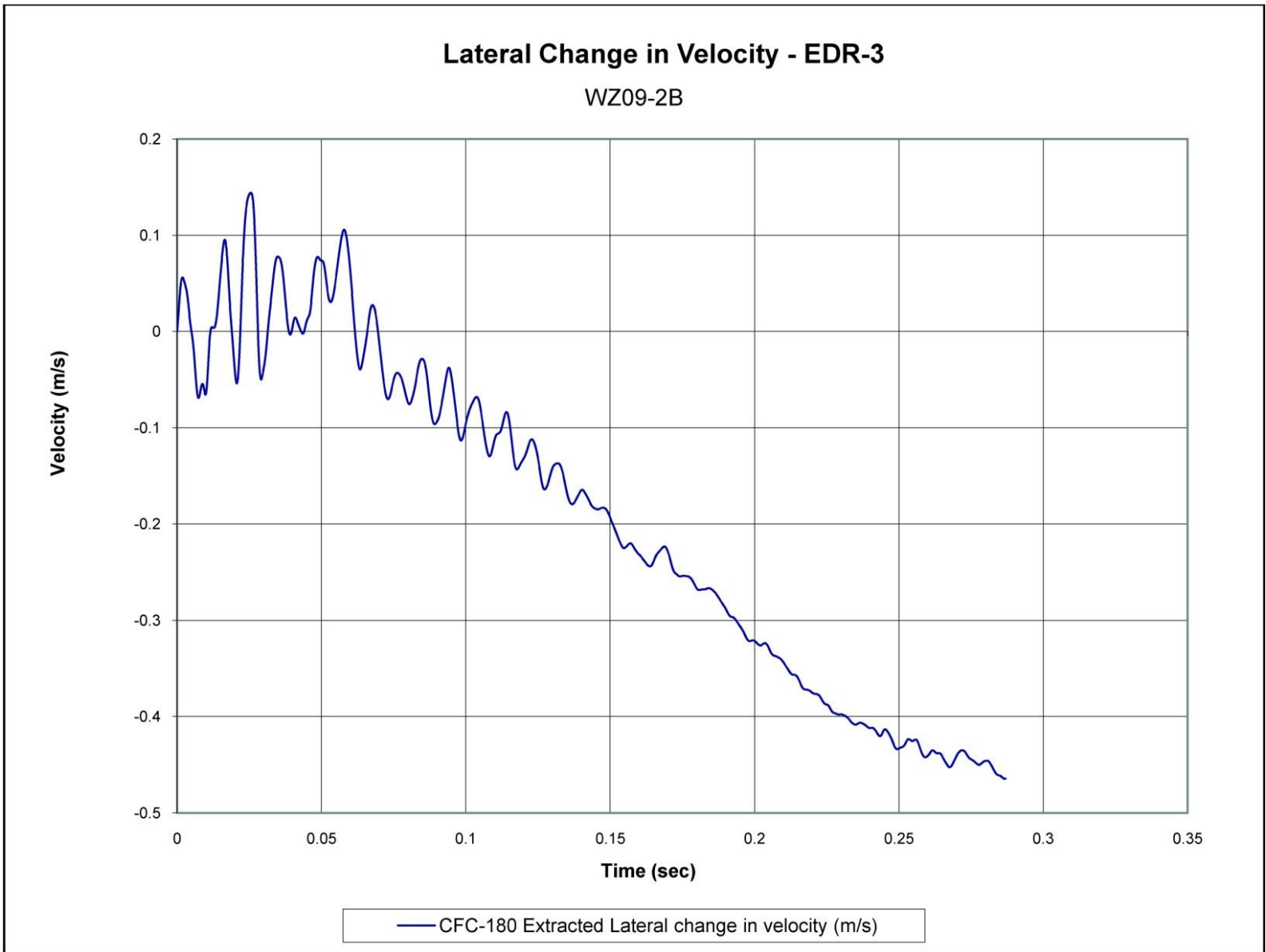

Figure G-18. Lateral Occupant Impact Velocity (EDR-3), Test No. WZ09-2B

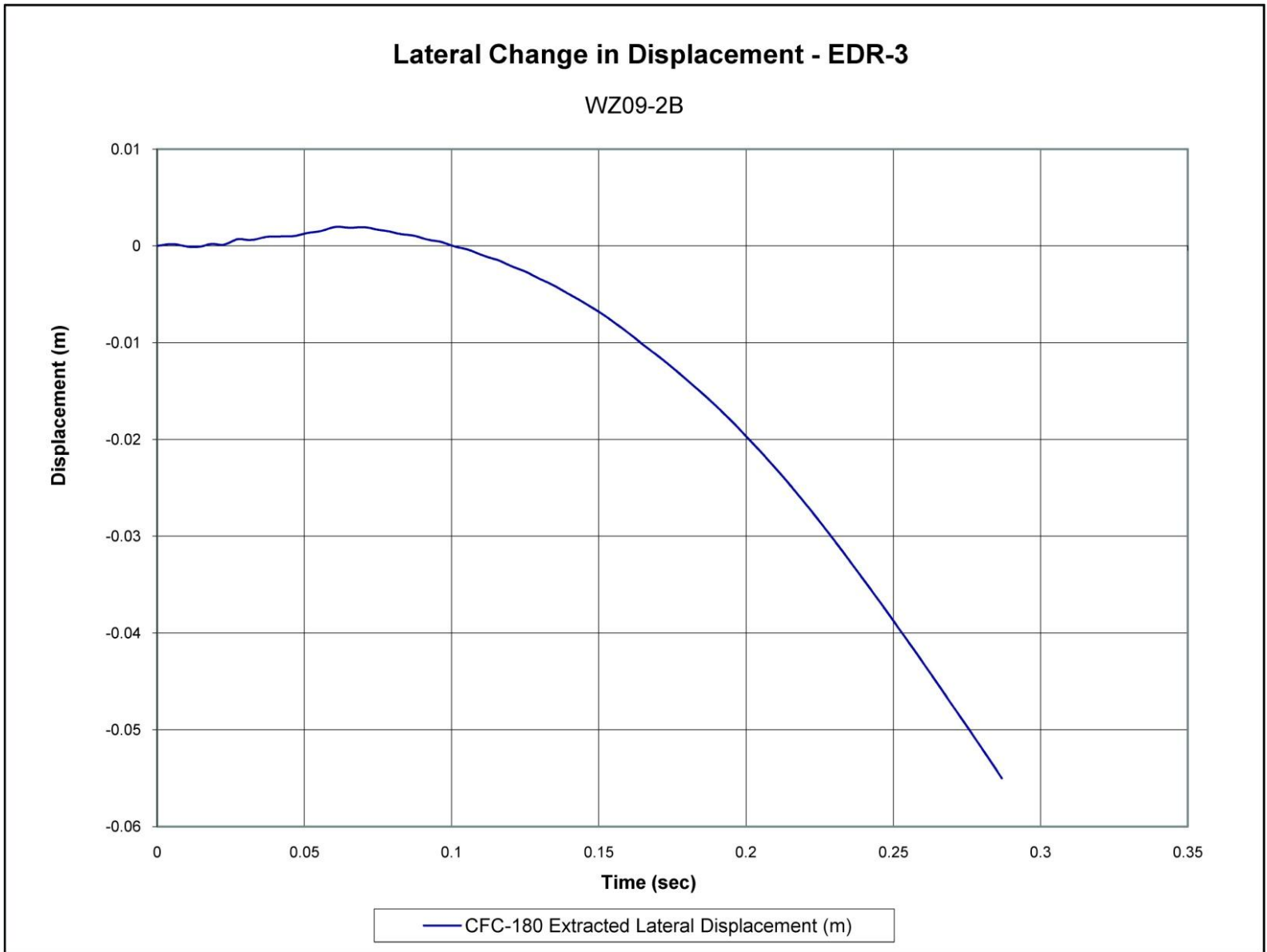

Figure G-19. Lateral Occupant Displacement (EDR-3), Test No. WZ09-2B

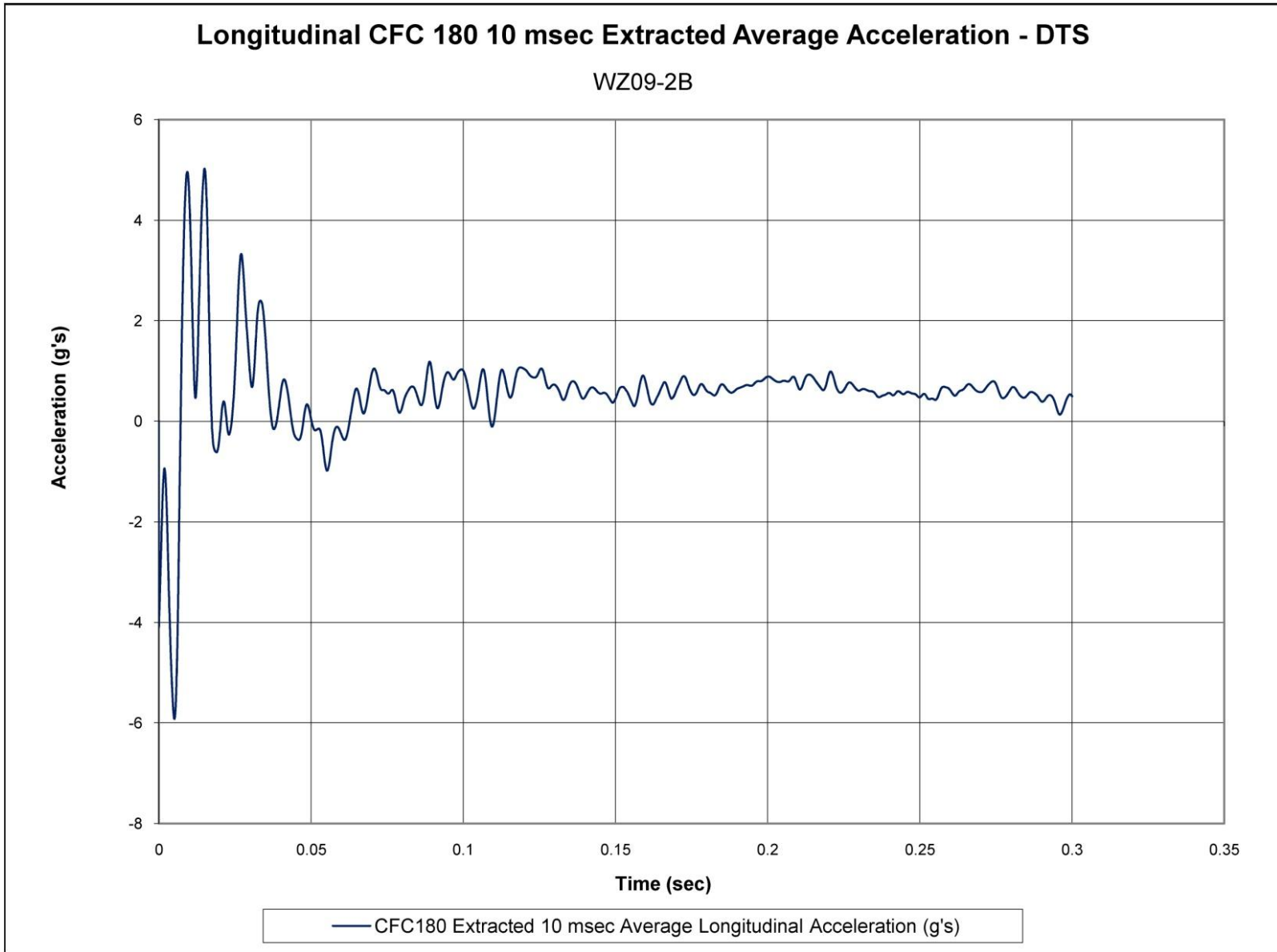

Figure G-20. 10-ms Average Longitudinal Deceleration (DTS), Test No. WZ09-2B

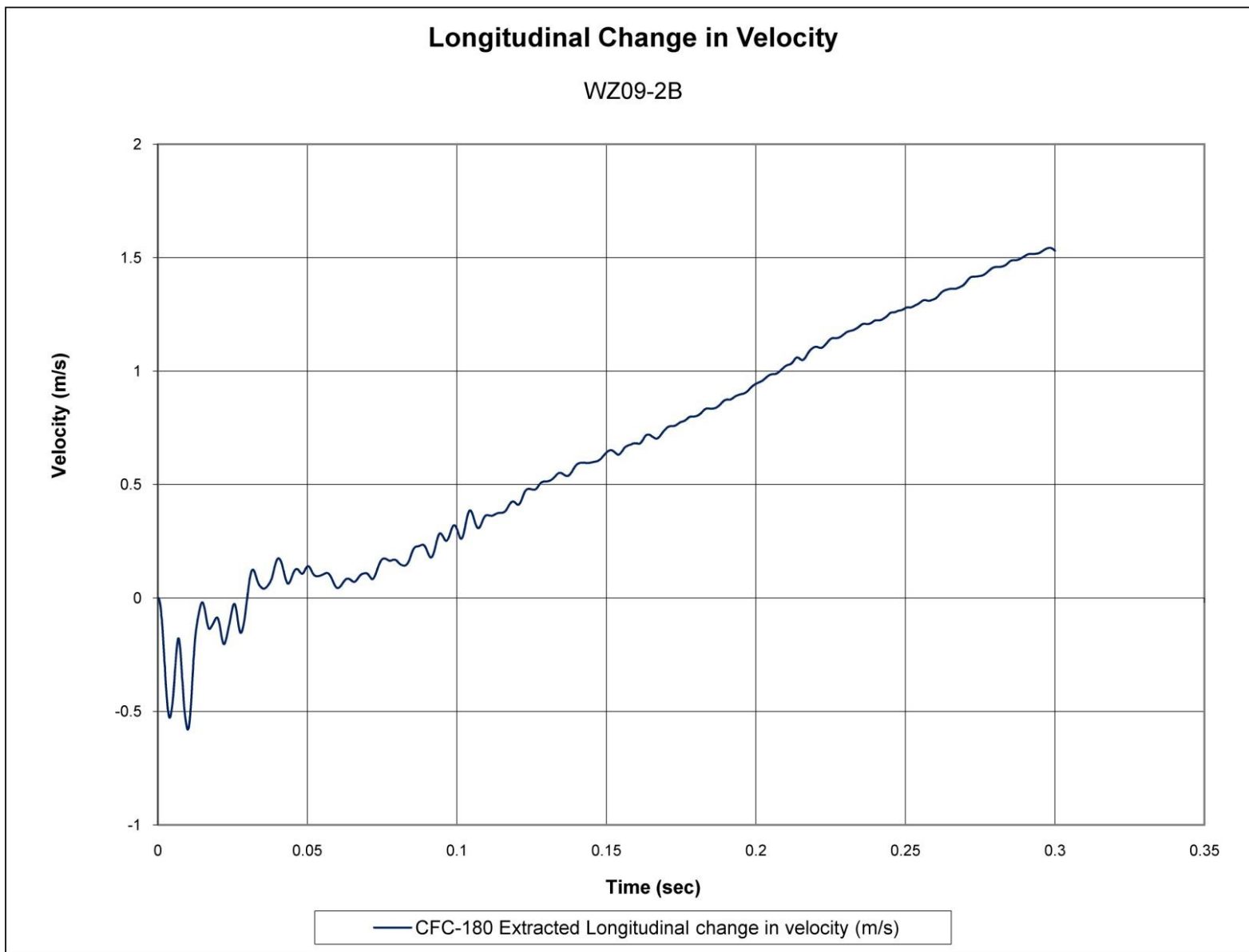

Figure G-21. Longitudinal Occupant Impact Velocity (DTS), Test No. WZ09-2B

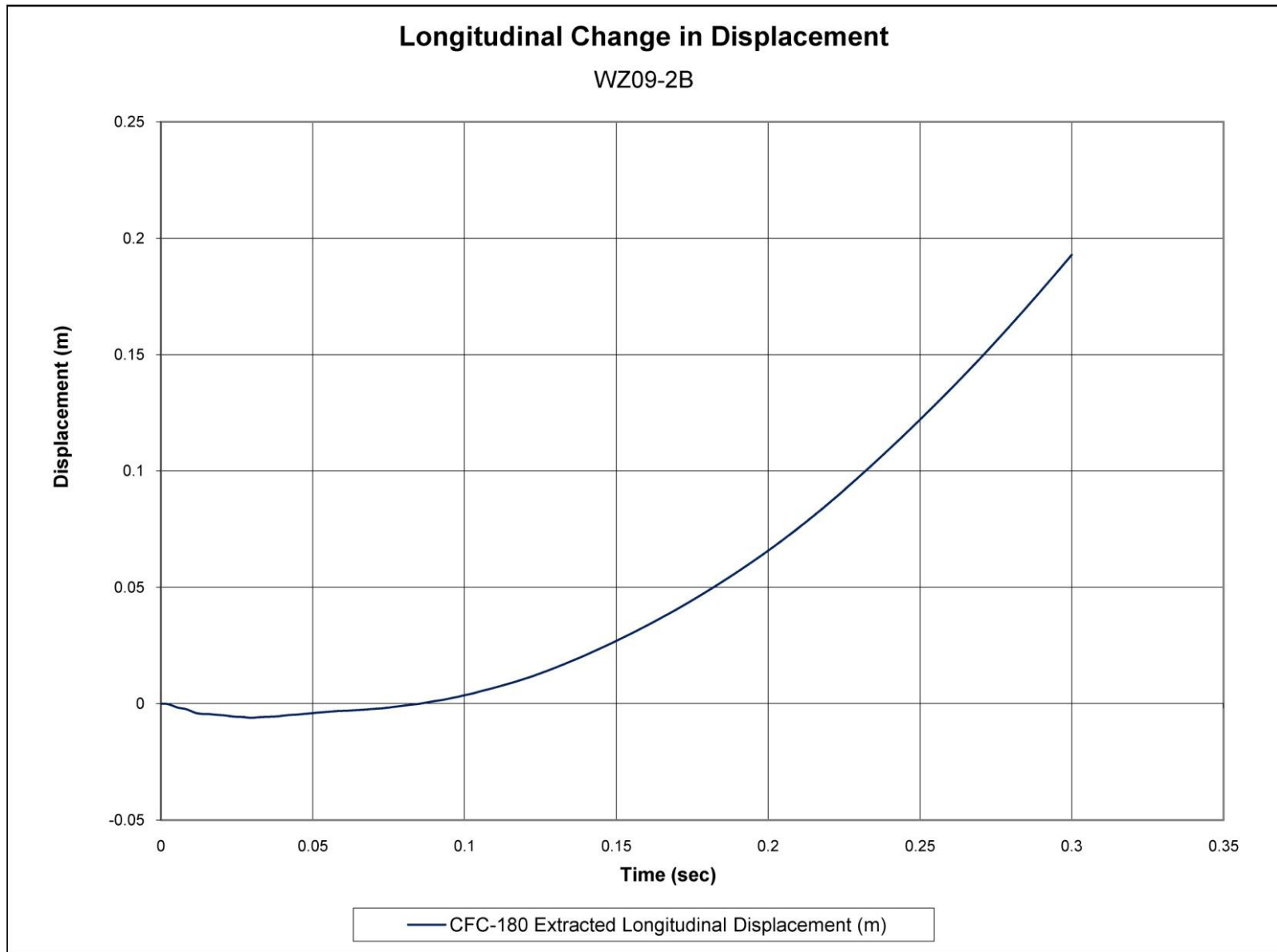

Figure G-22. Longitudinal Occupant Displacement (DTS), Test No. WZ09-2B

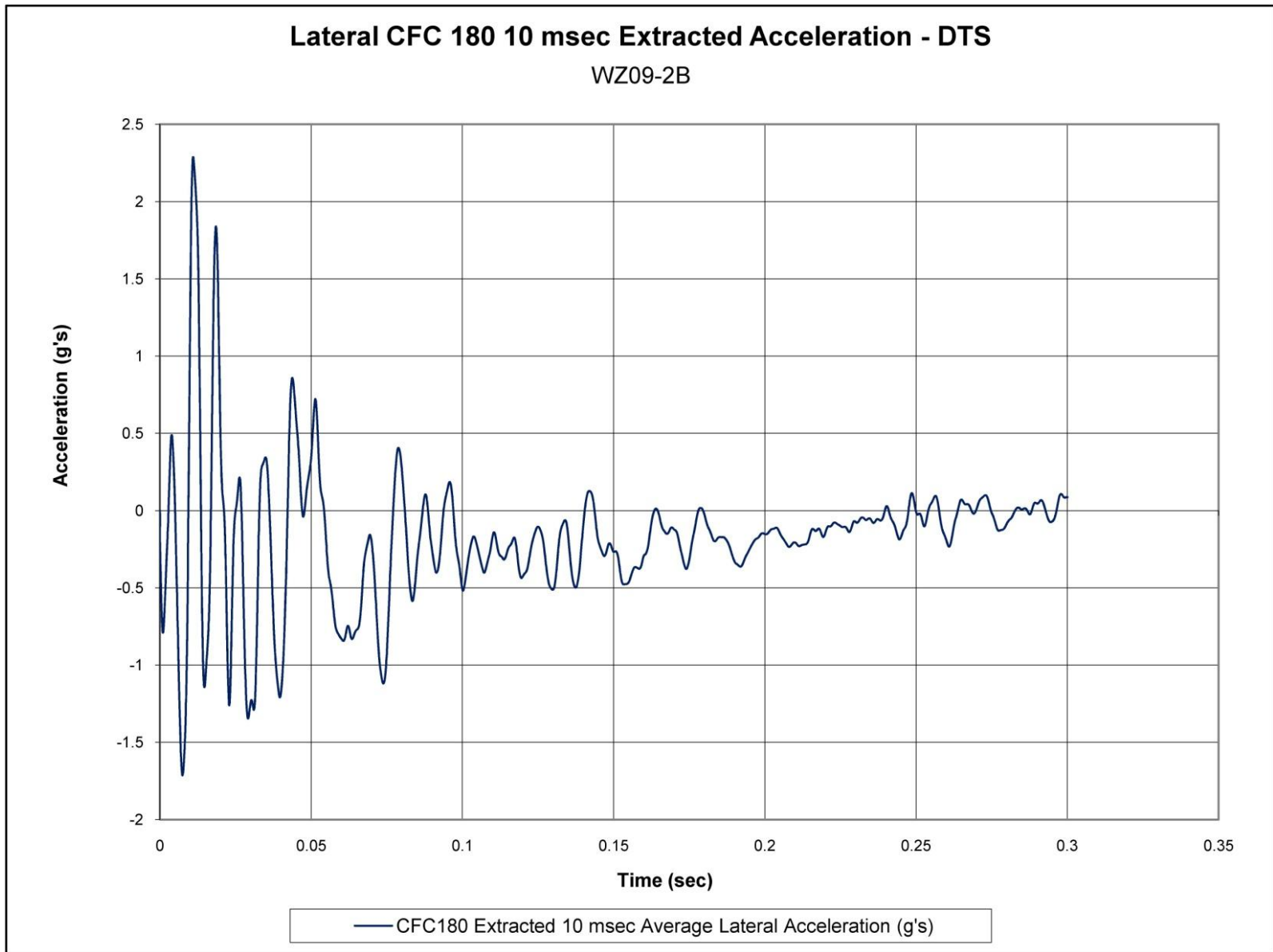

Figure G-23. 10-ms Average Lateral Deceleration (DTS), Test No. WZ09-2B

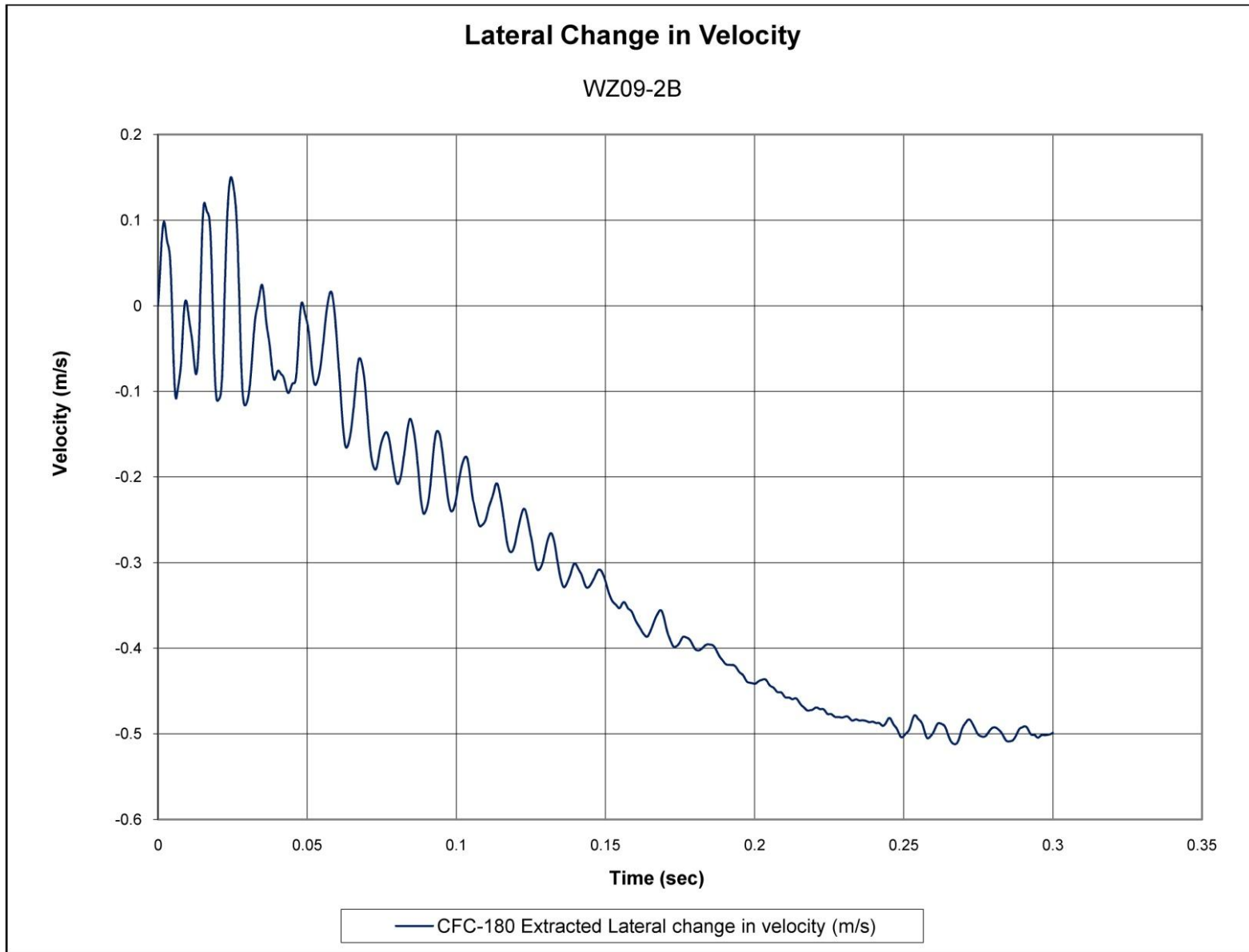

Figure G-24. Lateral Occupant Impact Velocity (DTS), Test No. WZ09-2B

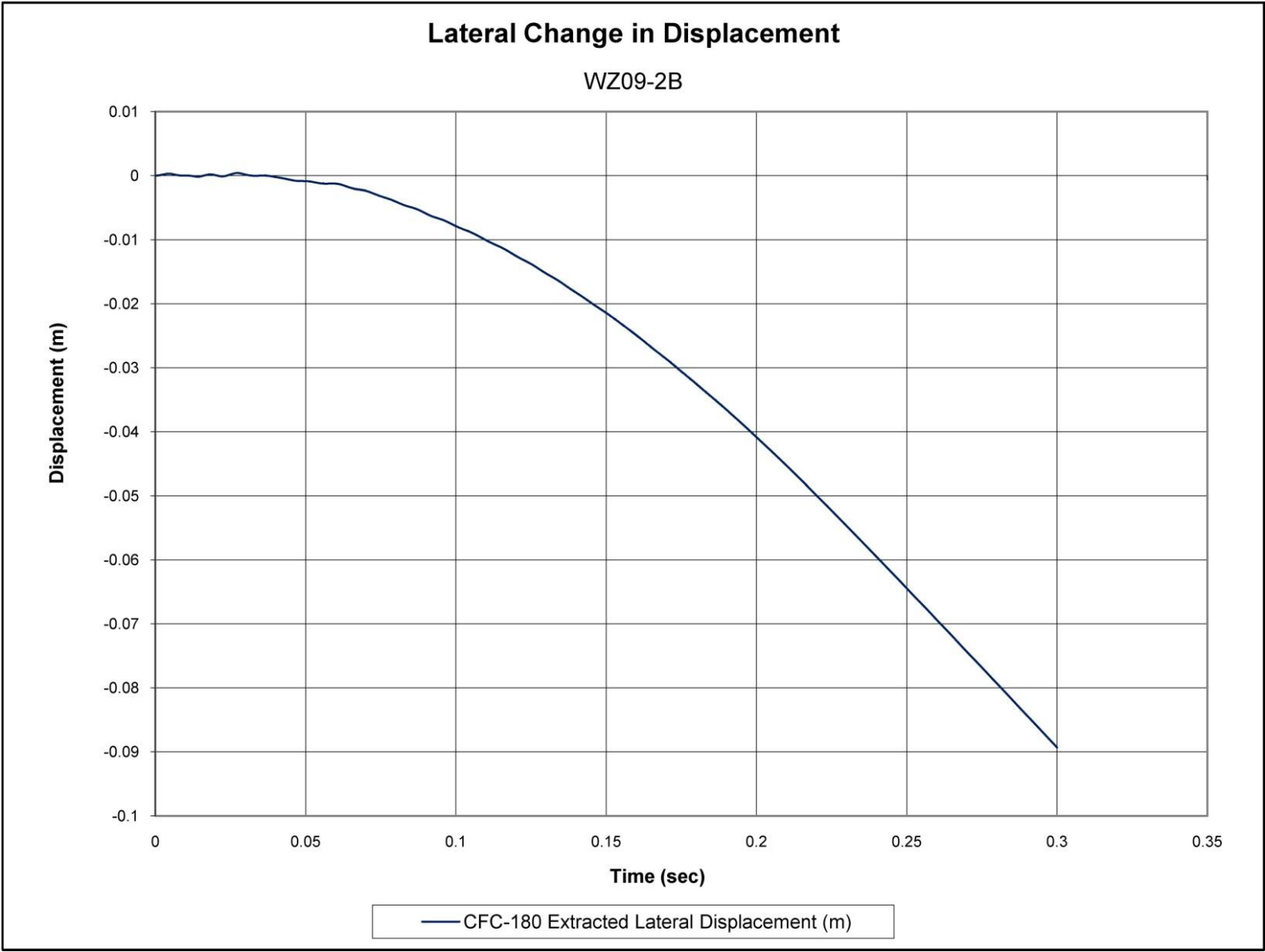

Figure G-25. Lateral Occupant Displacement (DTS), Test No. WZ09-2B

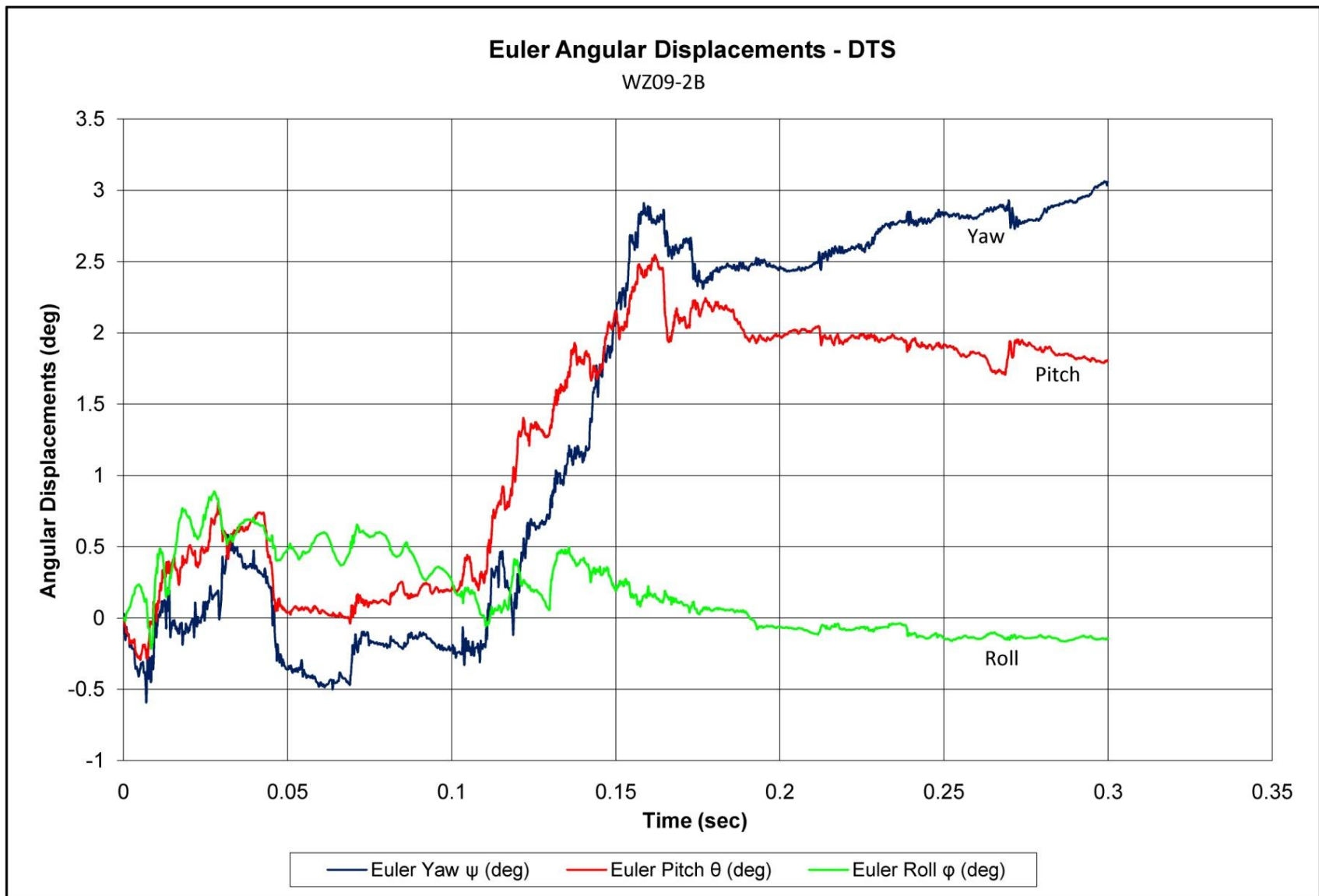

Figure G-26. Vehicle Angular Displacements (DTS), Test No. WZ09-2B

Appendix H. Accelerometer and Rate Transducer Plots, Test No. WZ09-3

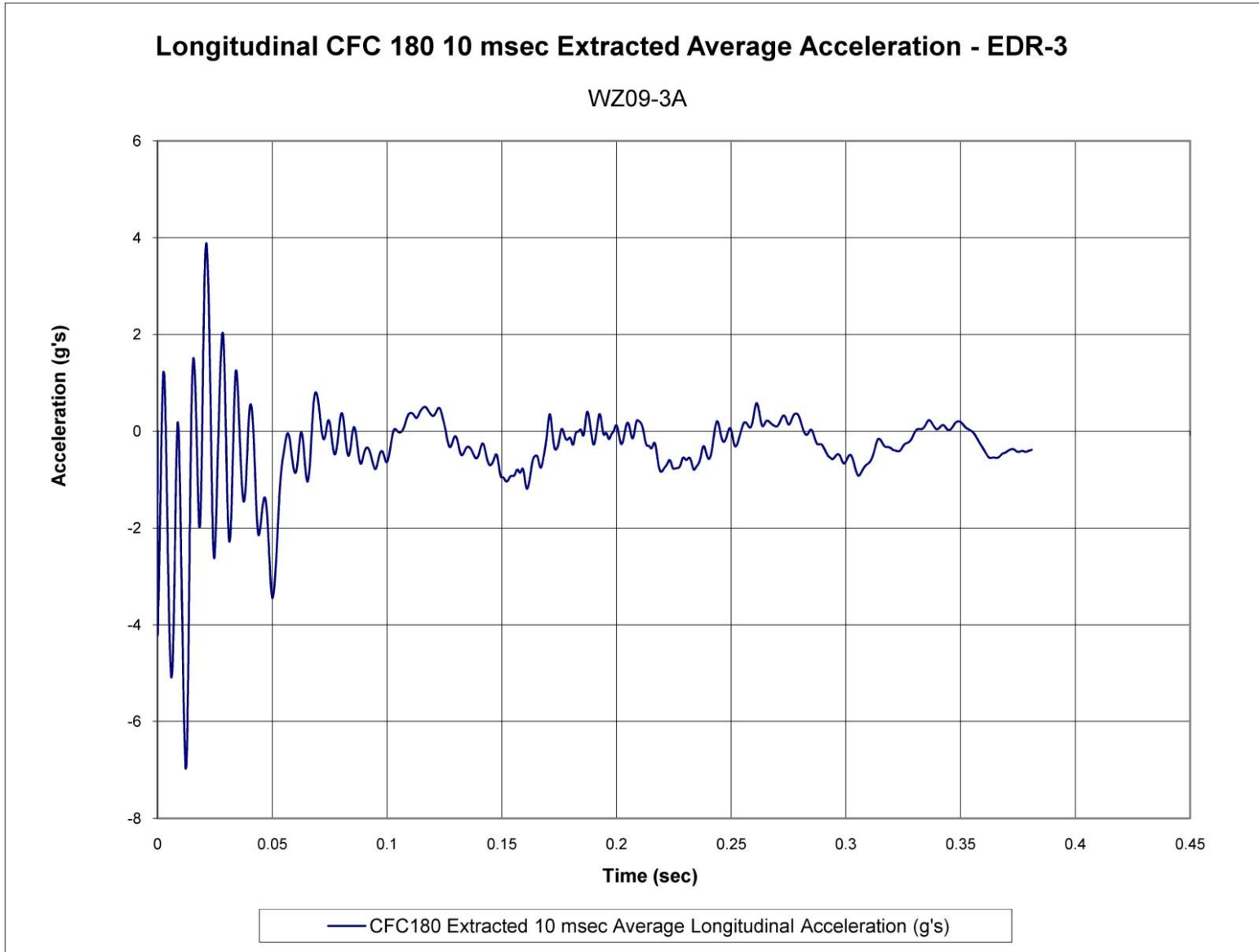

Figure H-1. 10-ms Average Longitudinal Deceleration (EDR-3), Test No. WZ09-3A

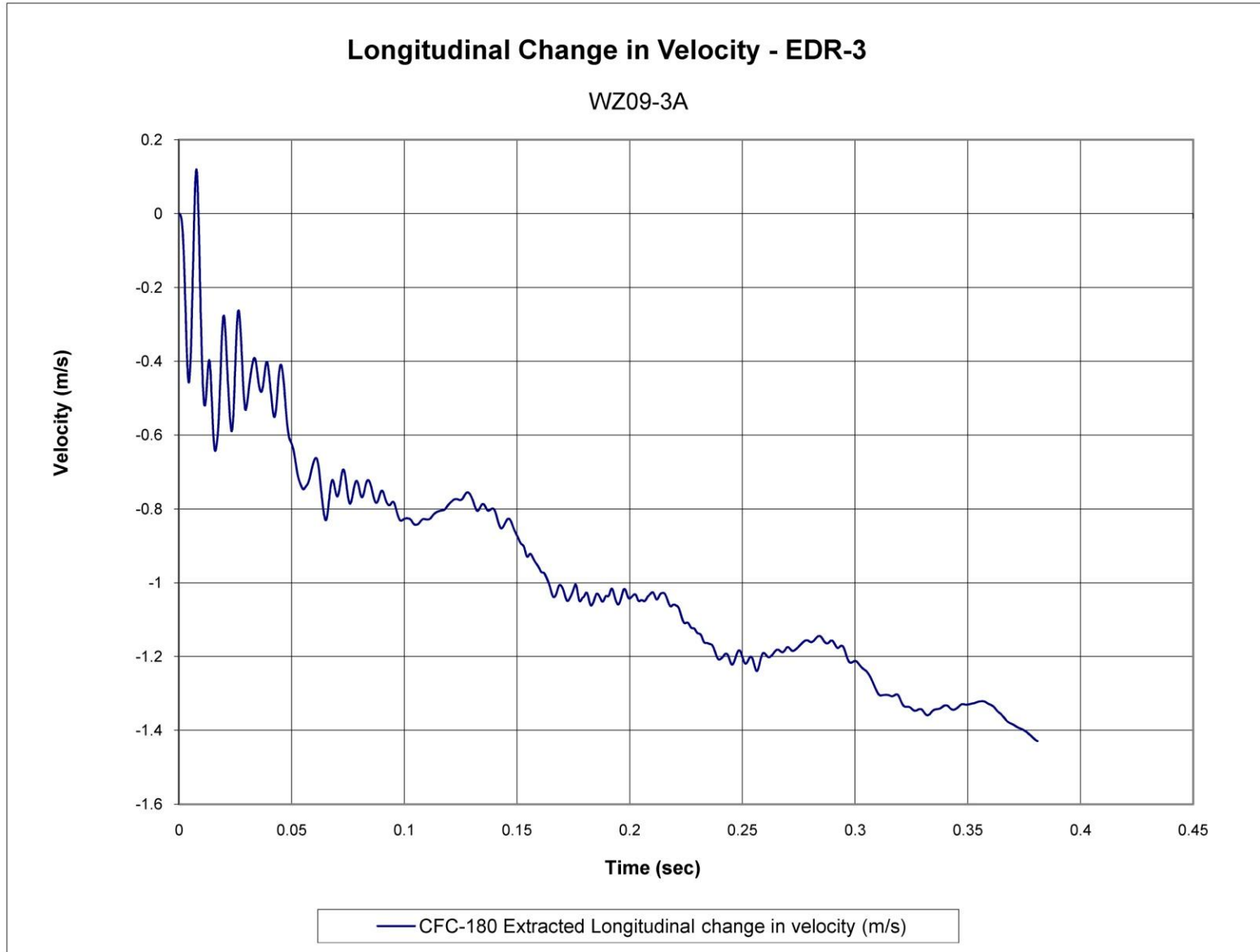

Figure H-2. Longitudinal Occupant Impact Velocity (EDR-3), Test No. WZ09-3A

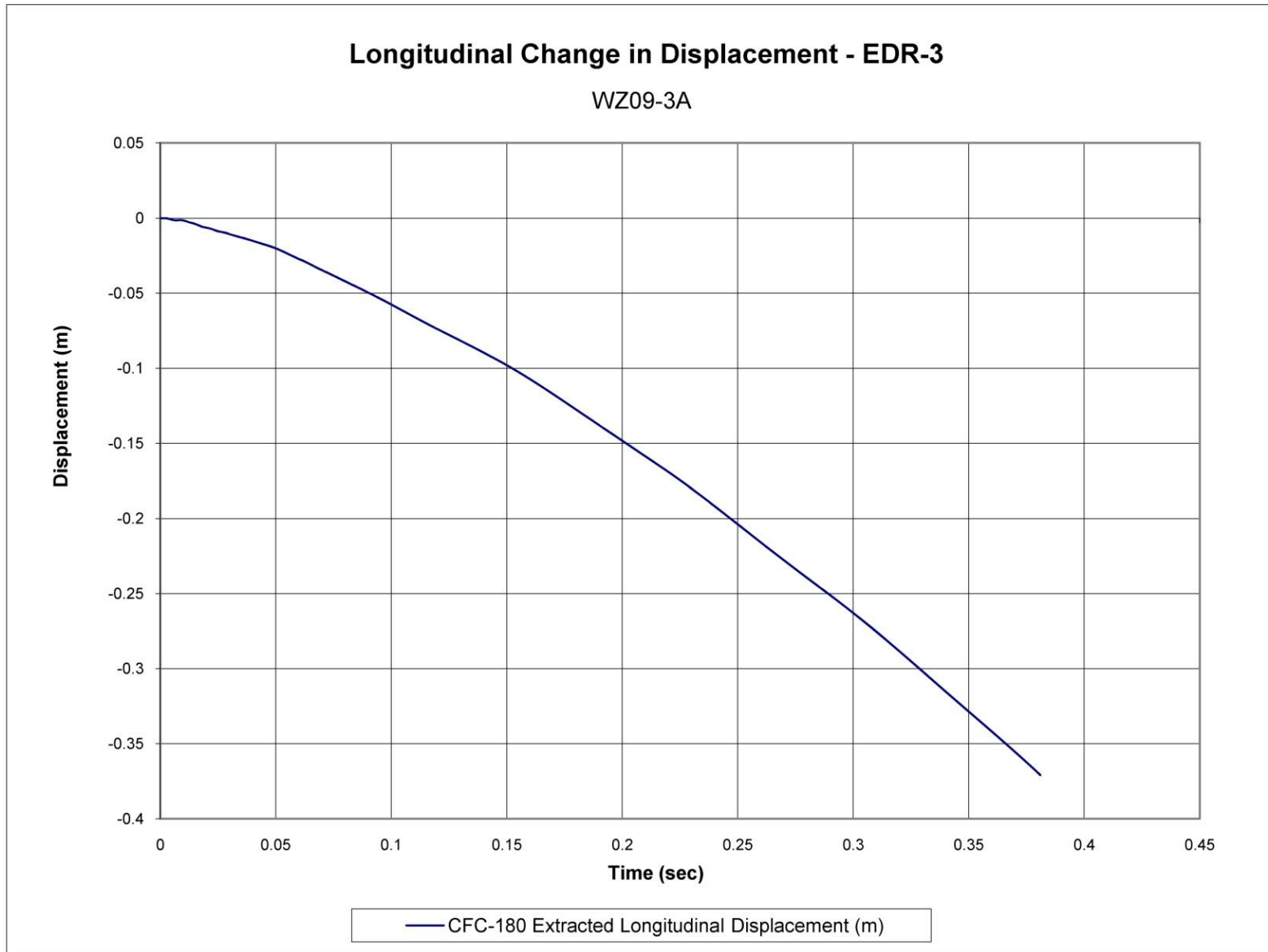

Figure H-3. Longitudinal Occupant Displacement (EDR-3), Test No. WZ09-3A

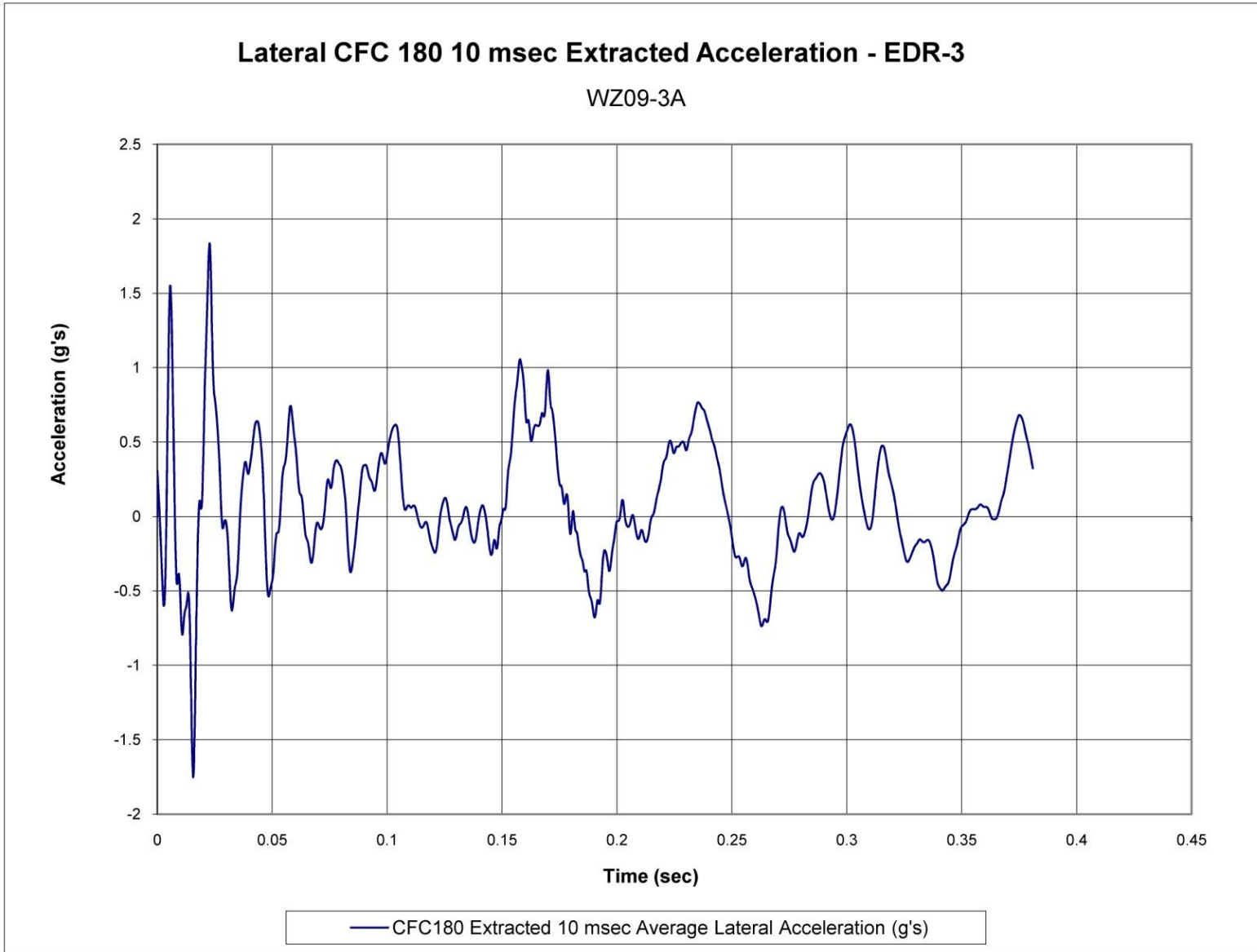

Figure H-4. 10-ms Average Lateral Deceleration (EDR-3), Test No. WZ09-3A

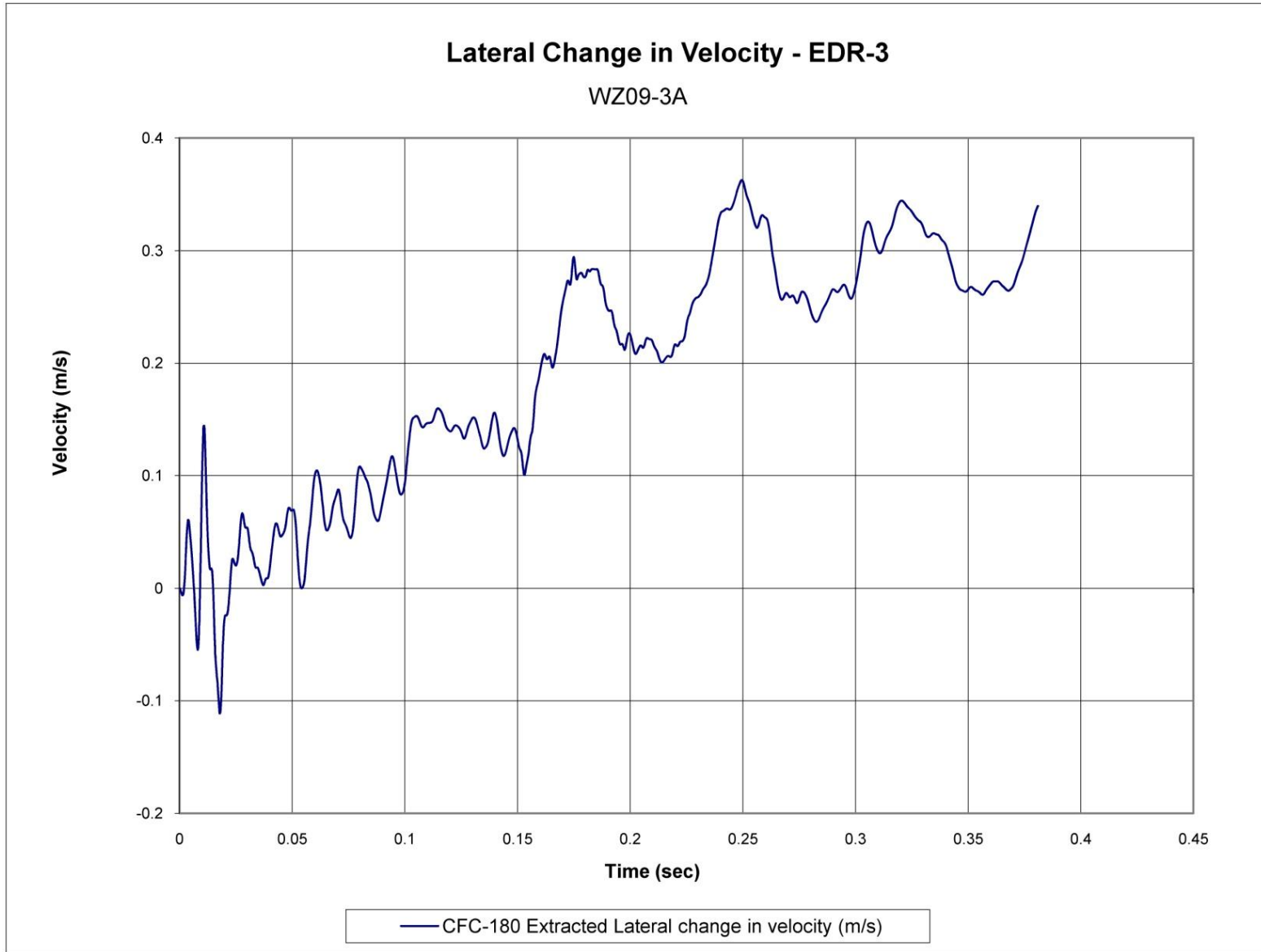

Figure H-5. Lateral Occupant Impact Velocity (EDR-3), Test No. WZ09-3A

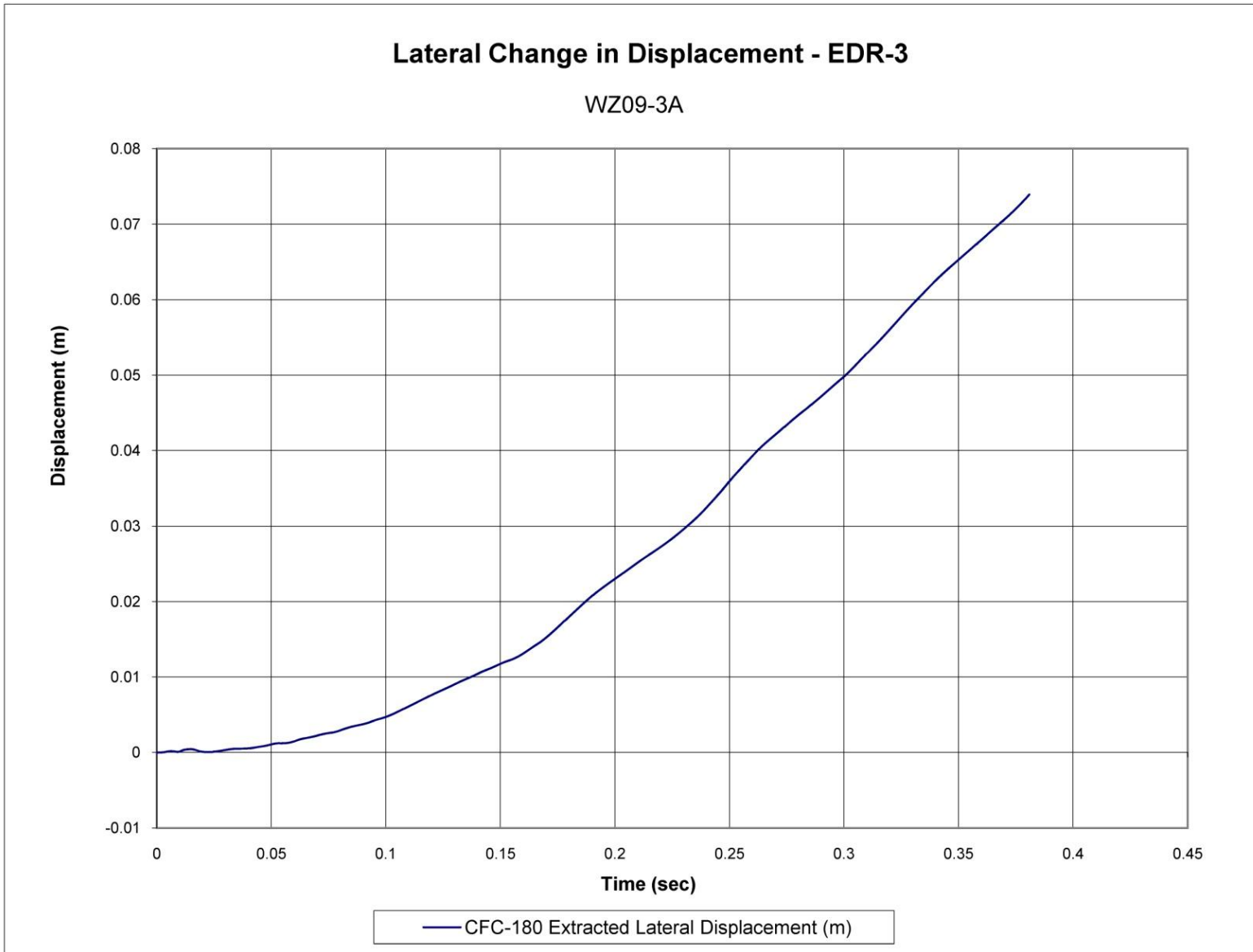

Figure H-6. Lateral Occupant Displacement (EDR-3), Test No. WZ09-3A

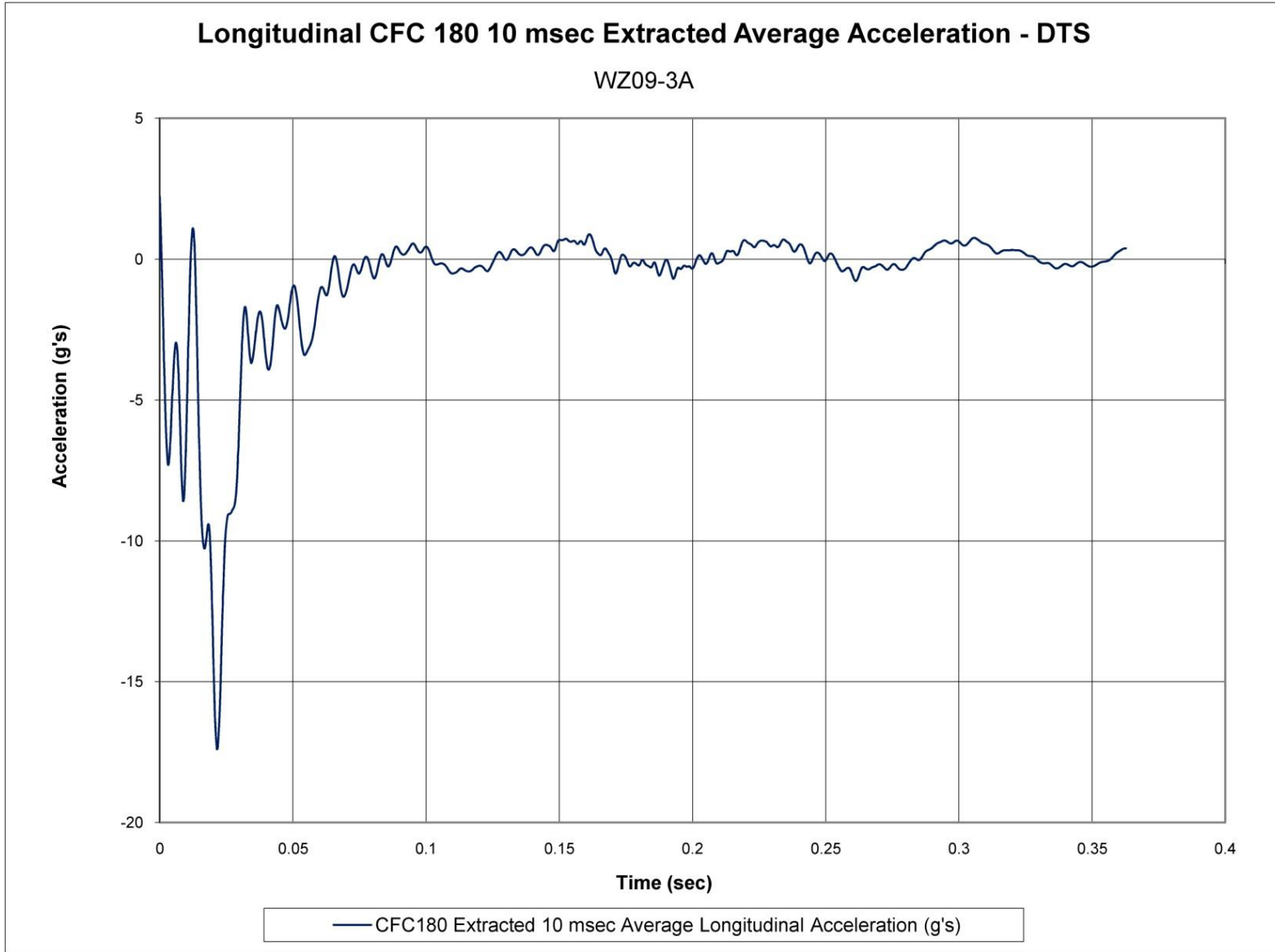

Figure H-7. 10-ms Average Longitudinal Deceleration (DTS), Test No. WZ09-3A

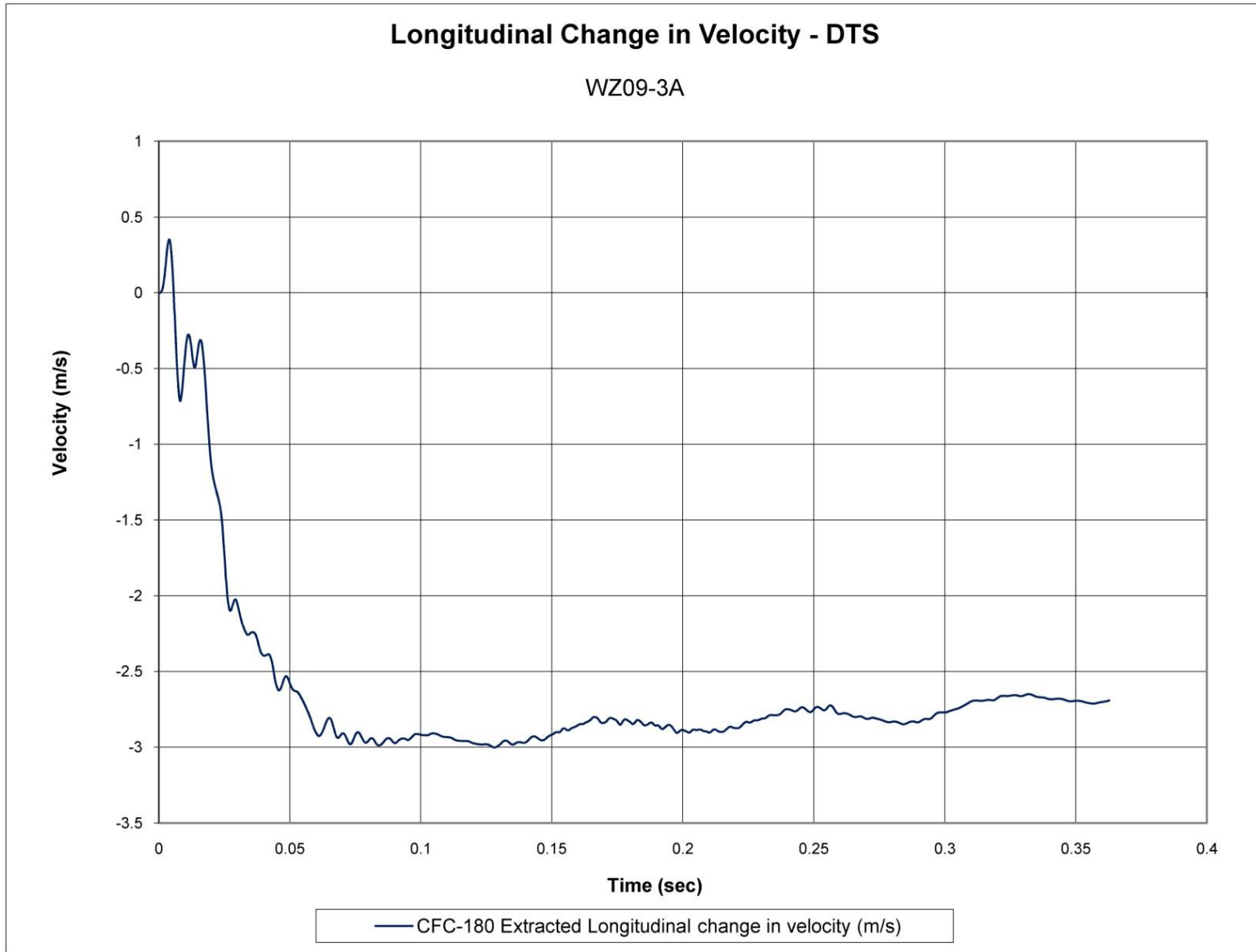

Figure H-8. Longitudinal Occupant Impact Velocity (DTS), Test No. WZ09-3A

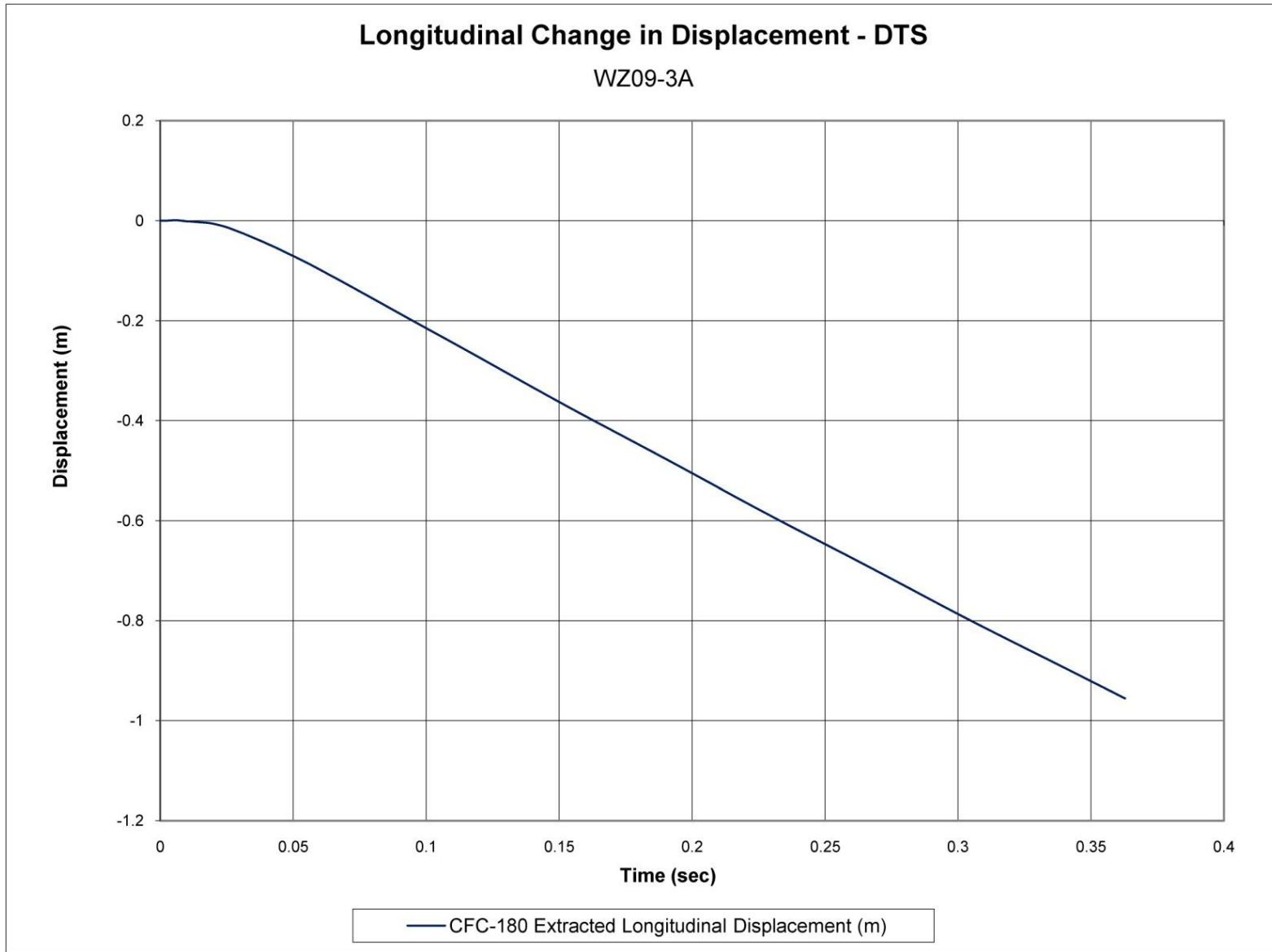

Figure H-9. Longitudinal Occupant Displacement (DTS), Test No. WZ09-3A

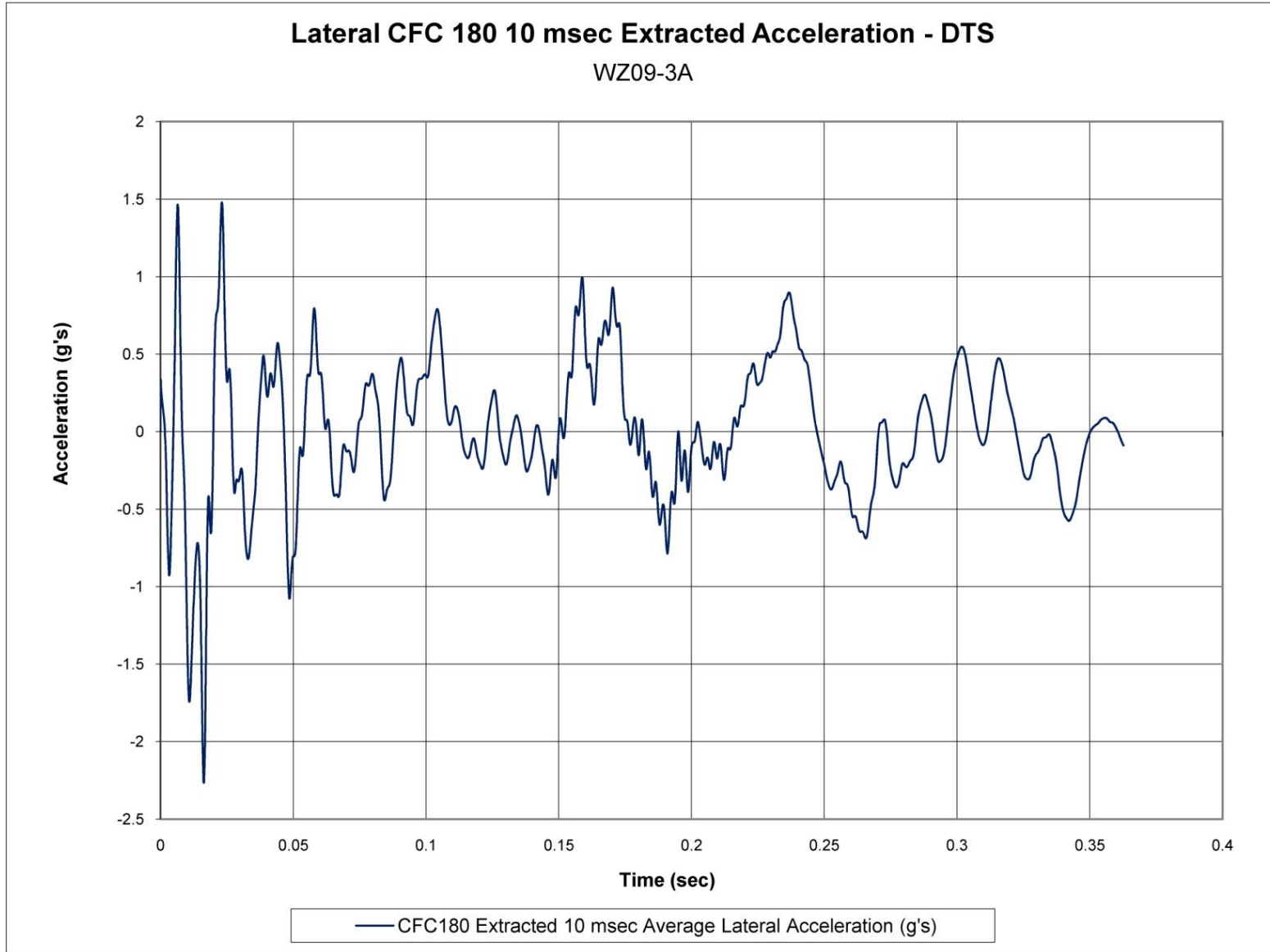

Figure H-10. 10-ms Average Lateral Deceleration (DTS), Test No. WZ09-3A

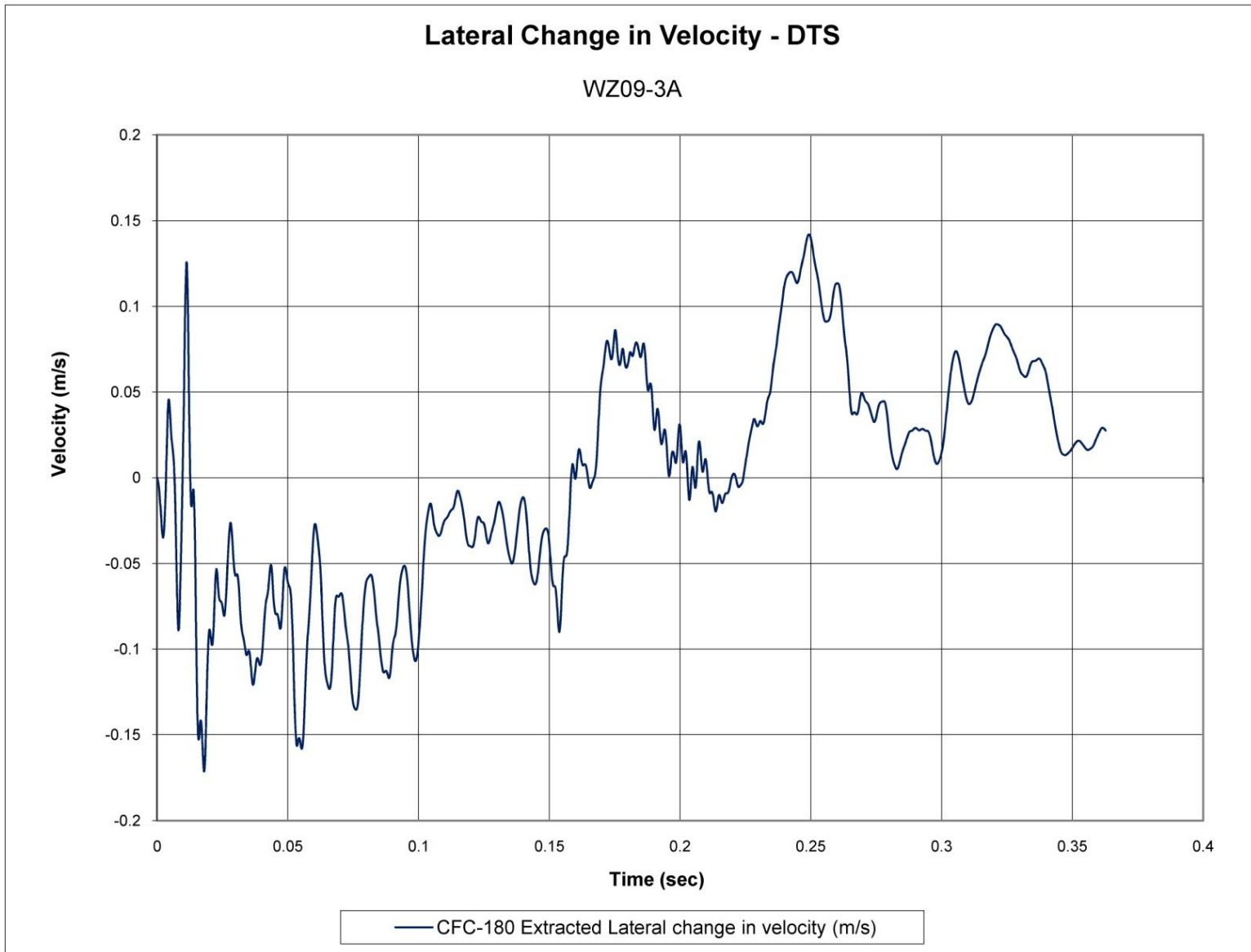

Figure H-11. Lateral Occupant Impact Velocity (DTS), Test No. WZ09-3A

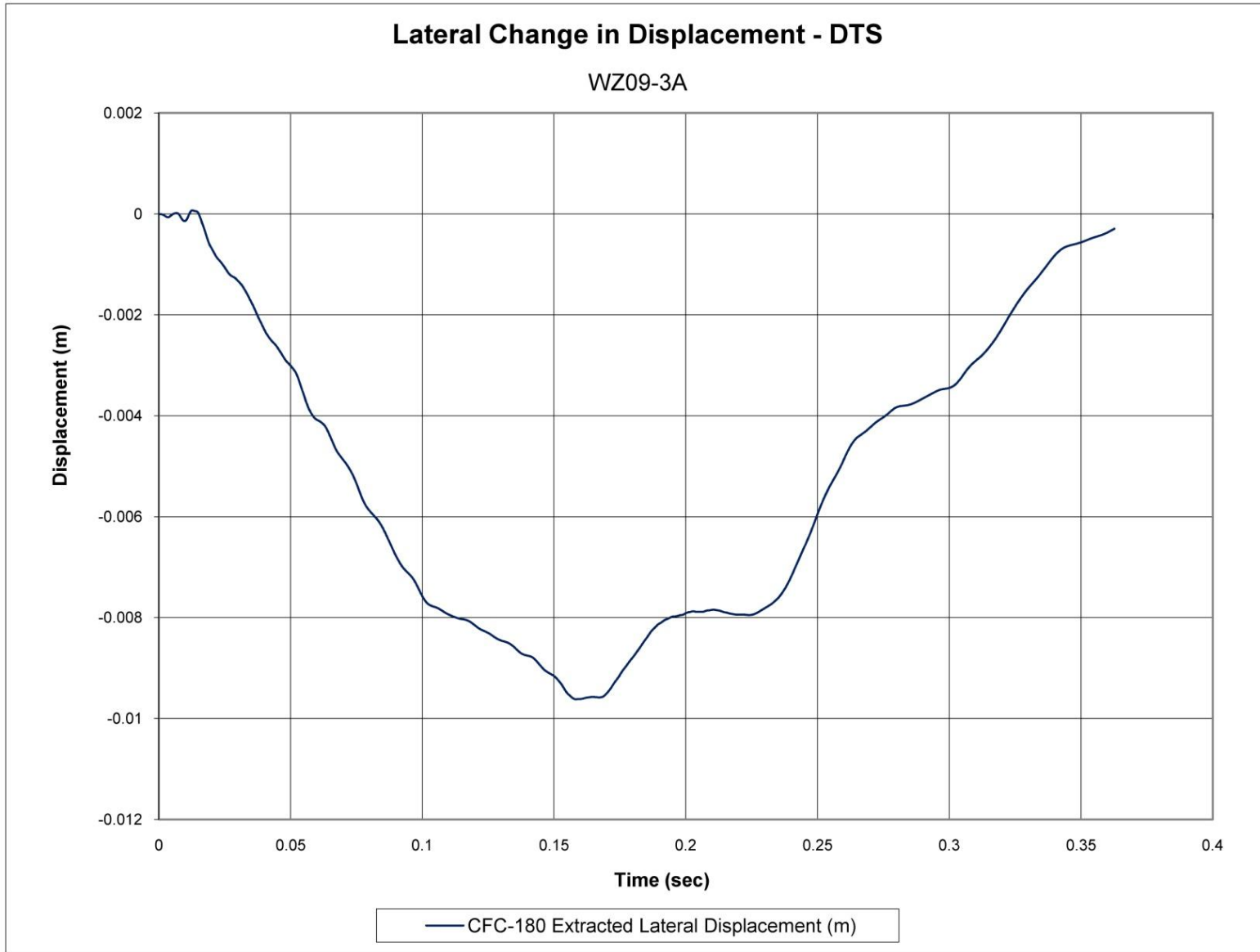

Figure H-12. Lateral Occupant Displacement (DTS), Test No. WZ09-3A

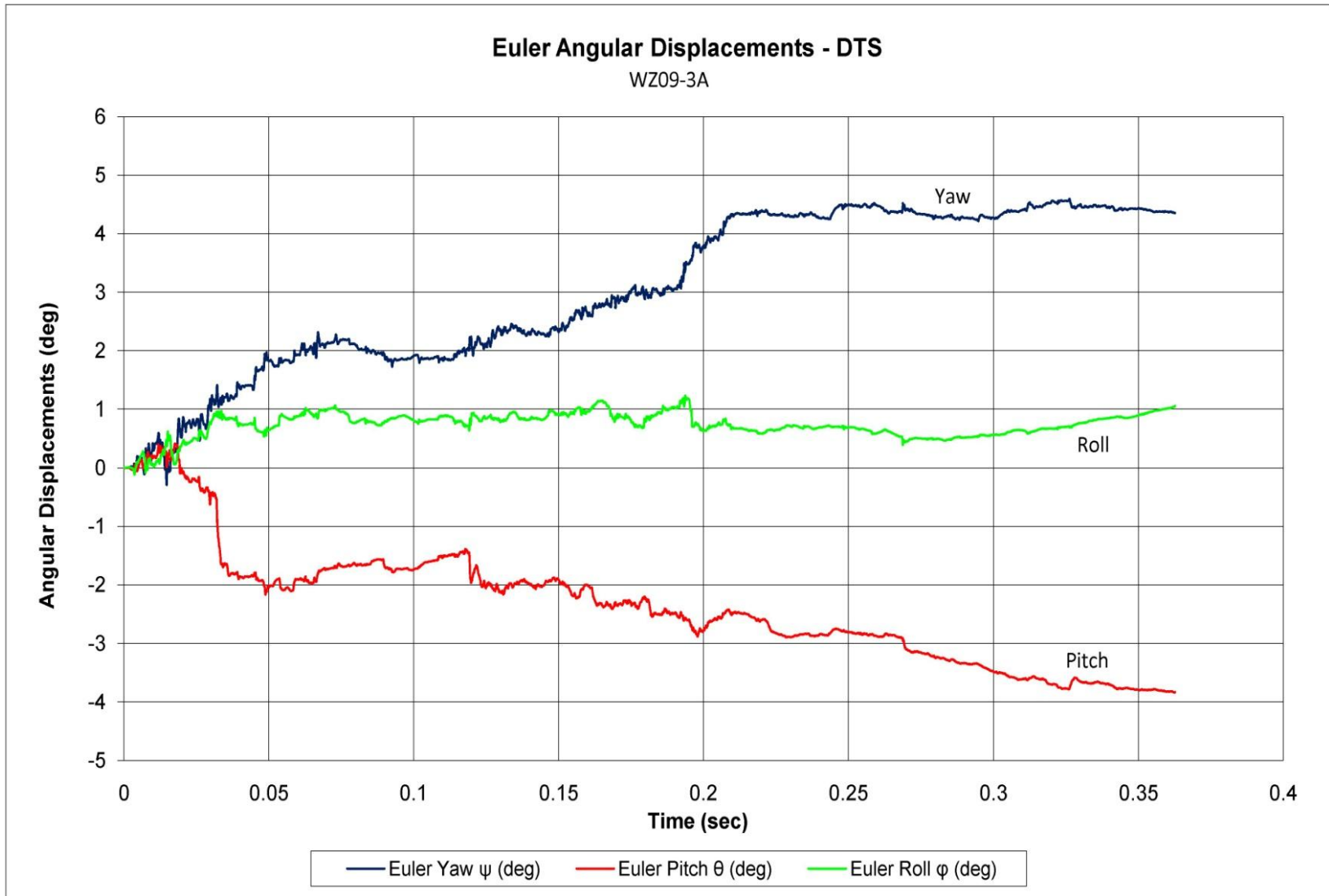

Figure H-13. Vehicle Angular Displacements (DTS), Test No. WZ09-3A

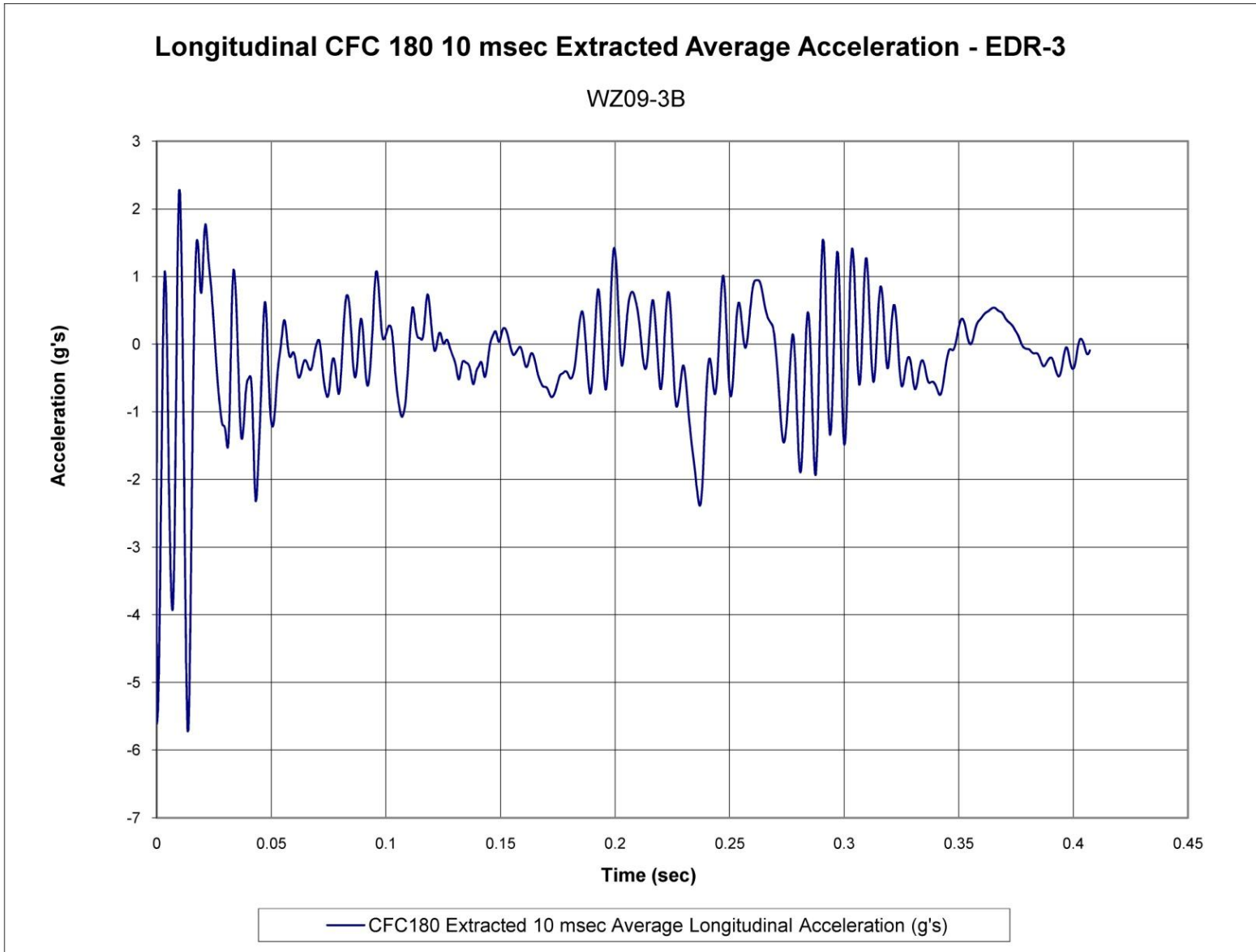

Figure H-14. 10-ms Average Longitudinal Deceleration (EDR-3), Test No. WZ09-3B

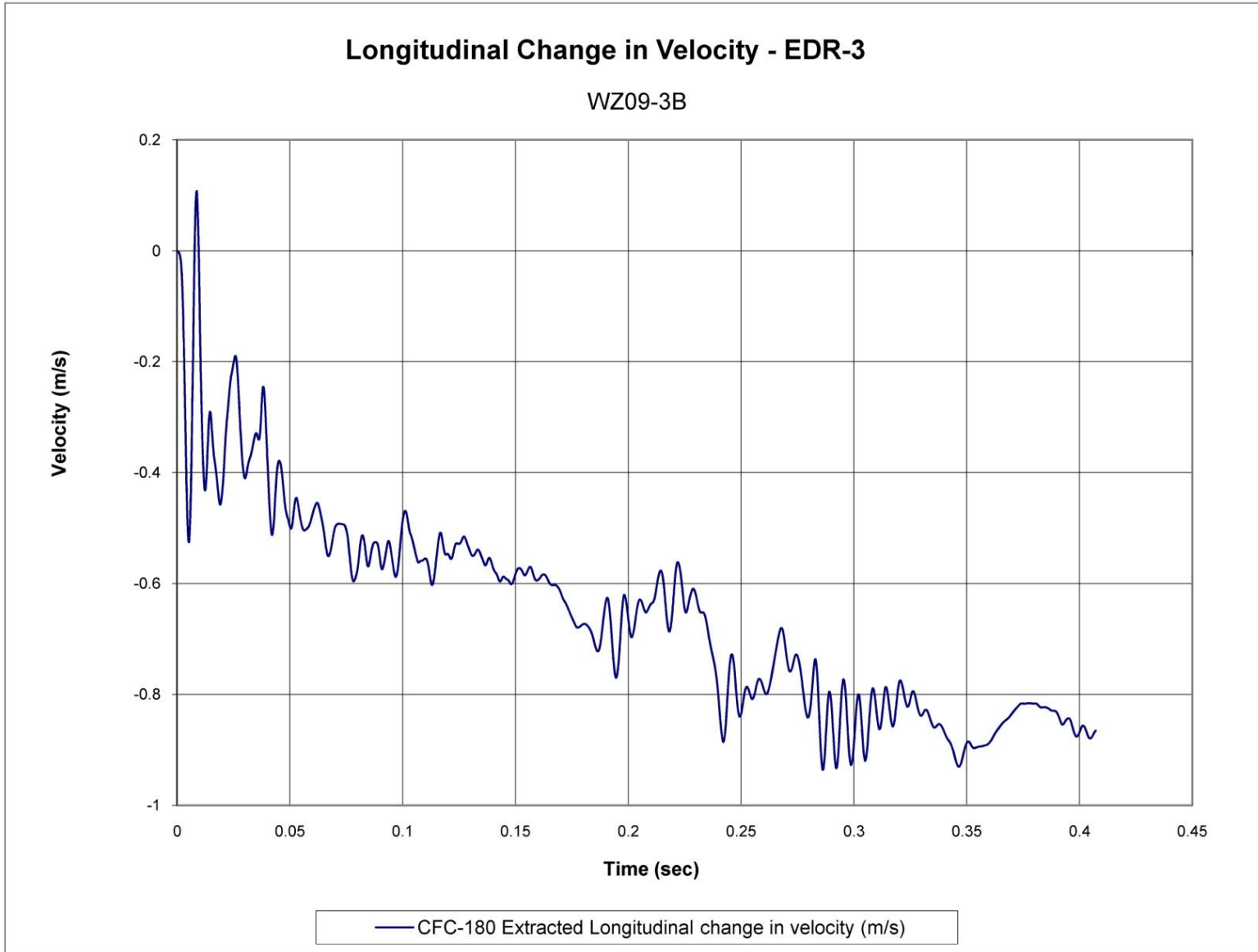

Figure H-15. Longitudinal Occupant Impact Velocity (EDR-3), Test No. WZ09-3B

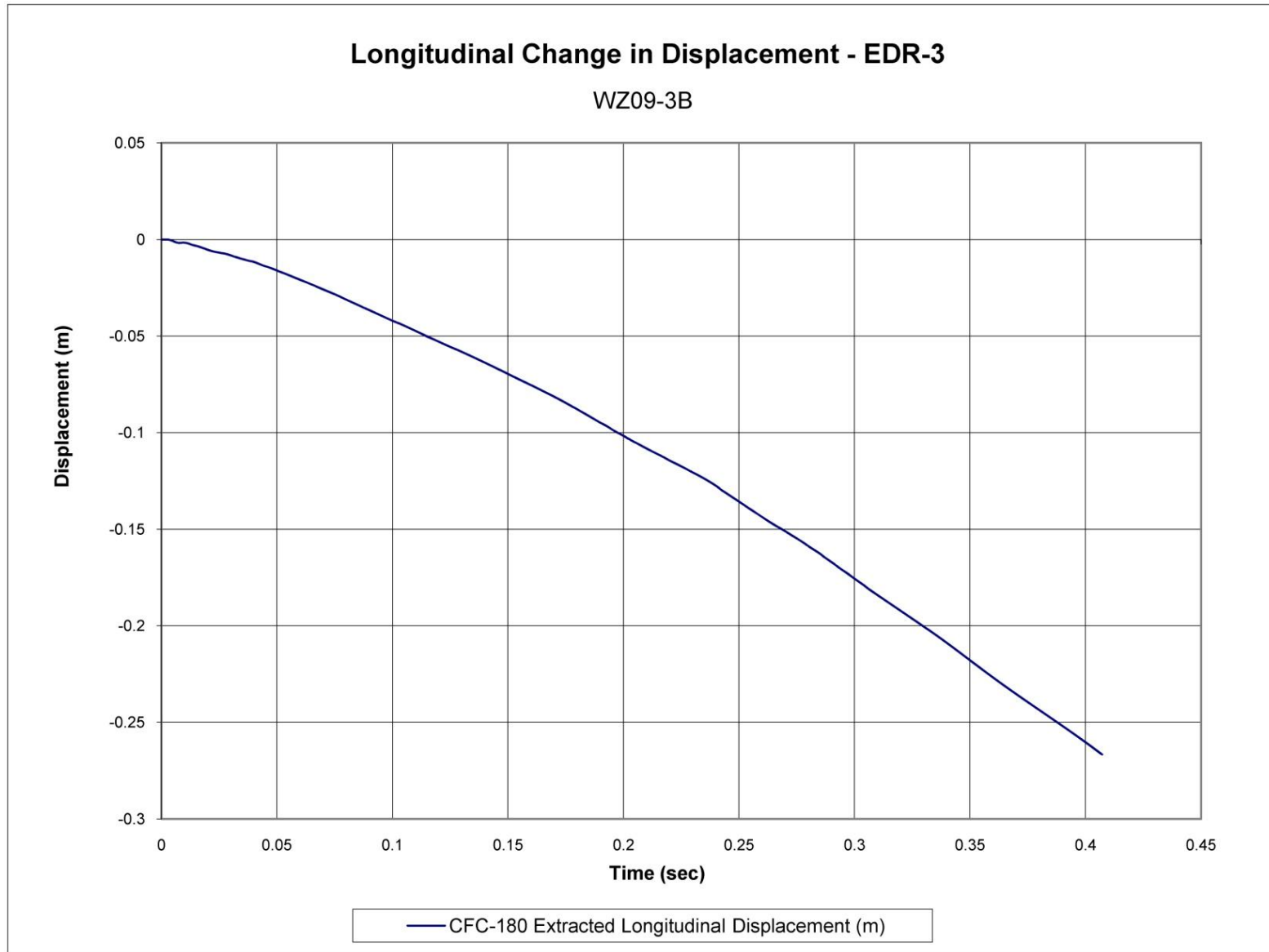

Figure H-16. Longitudinal Occupant Displacement (EDR-3), Test No. WZ09-3B

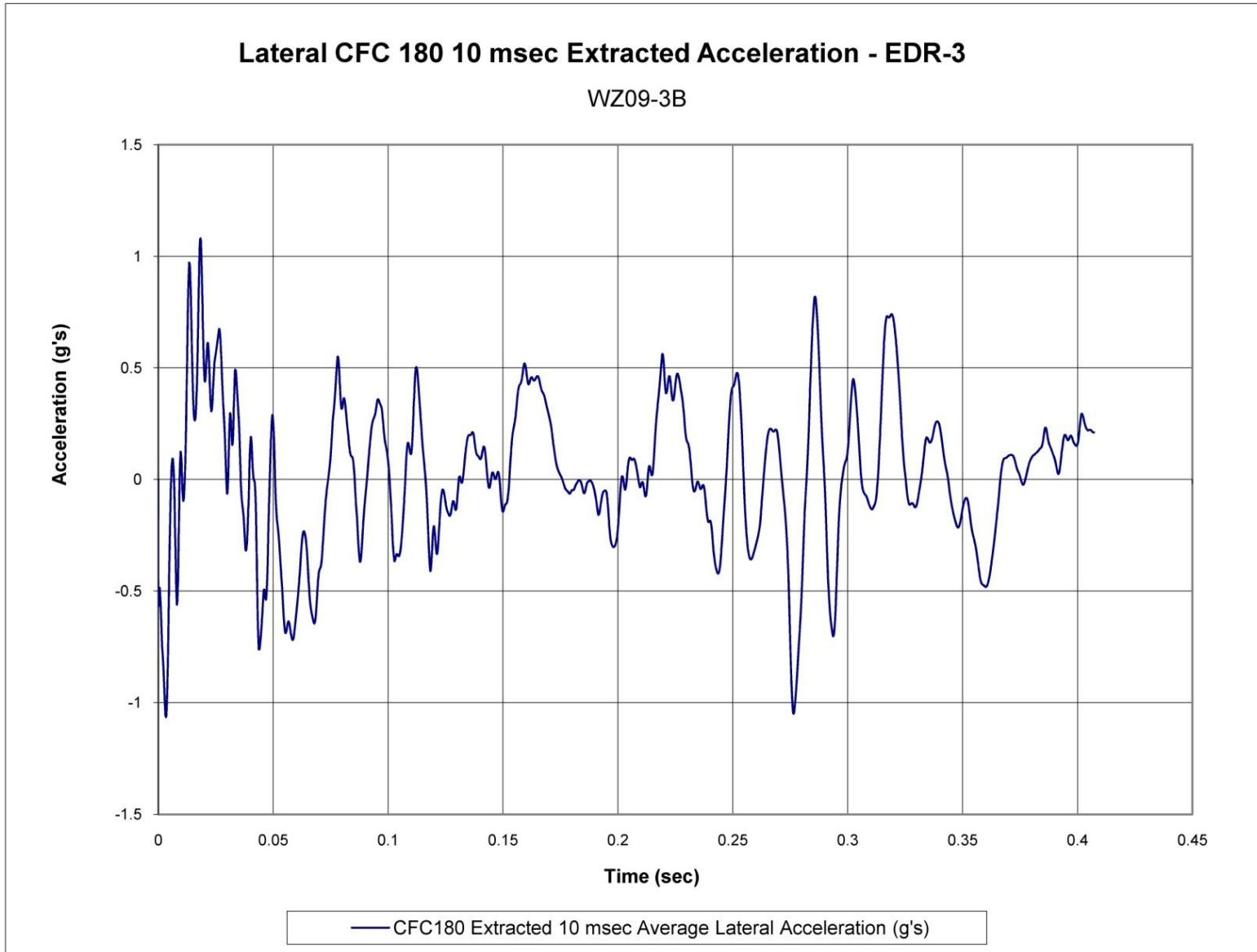

Figure H-17. 10-ms Average Lateral Deceleration (EDR-3), Test No. WZ09-3B

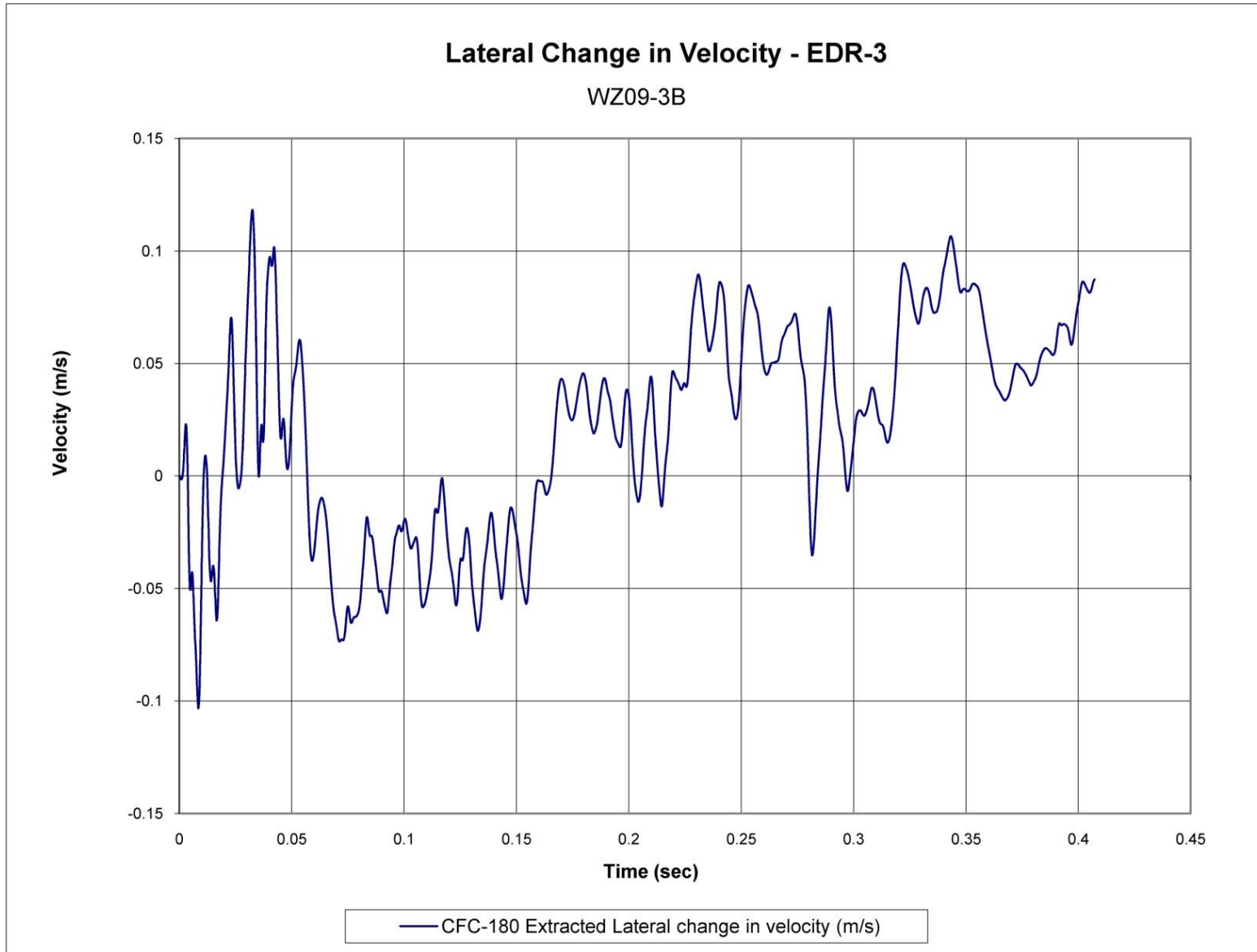

Figure H-18. Lateral Occupant Impact Velocity (EDR-3), Test No. WZ09-3B

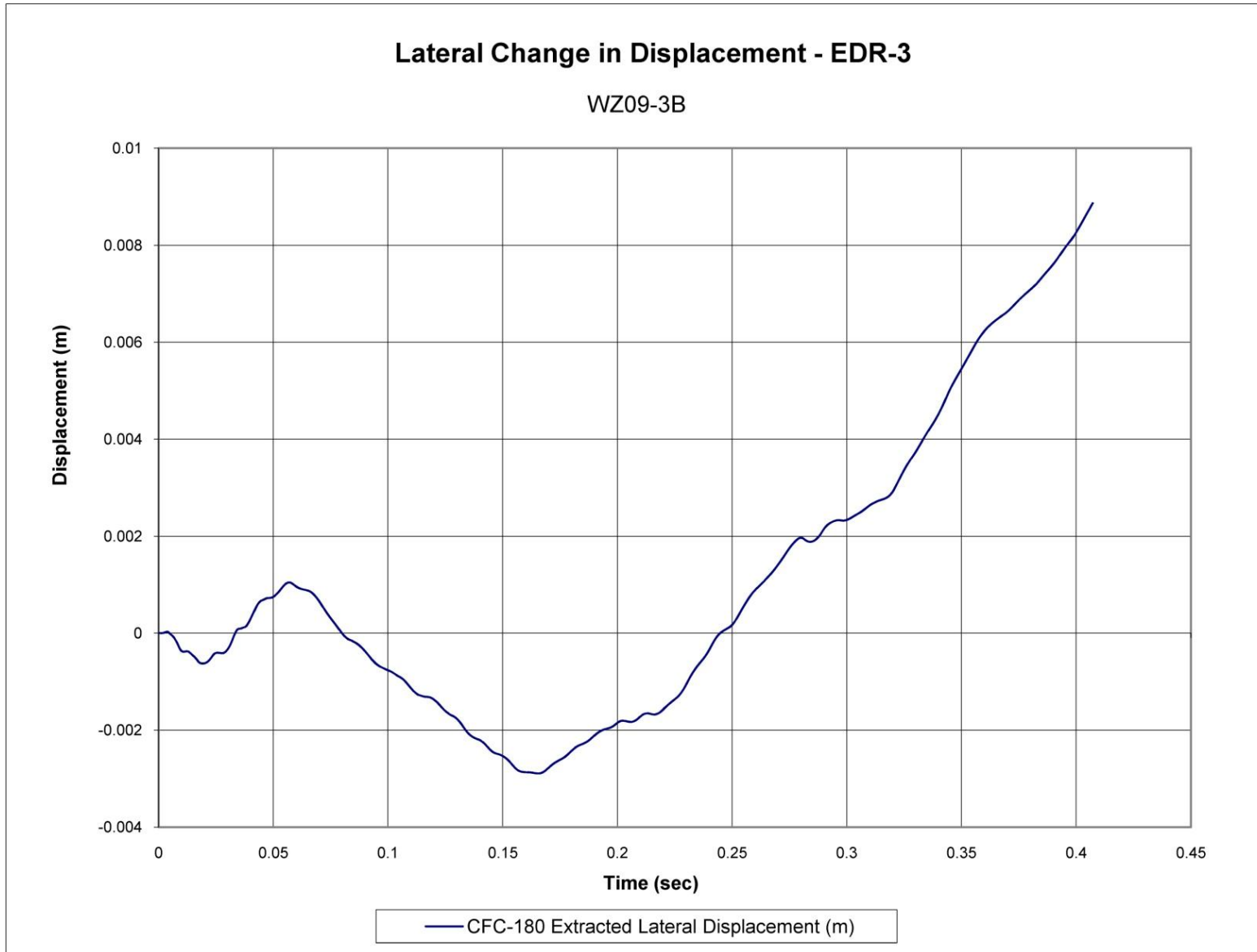

Figure H-19. Lateral Occupant Displacement (EDR-3), Test No. WZ09-3B

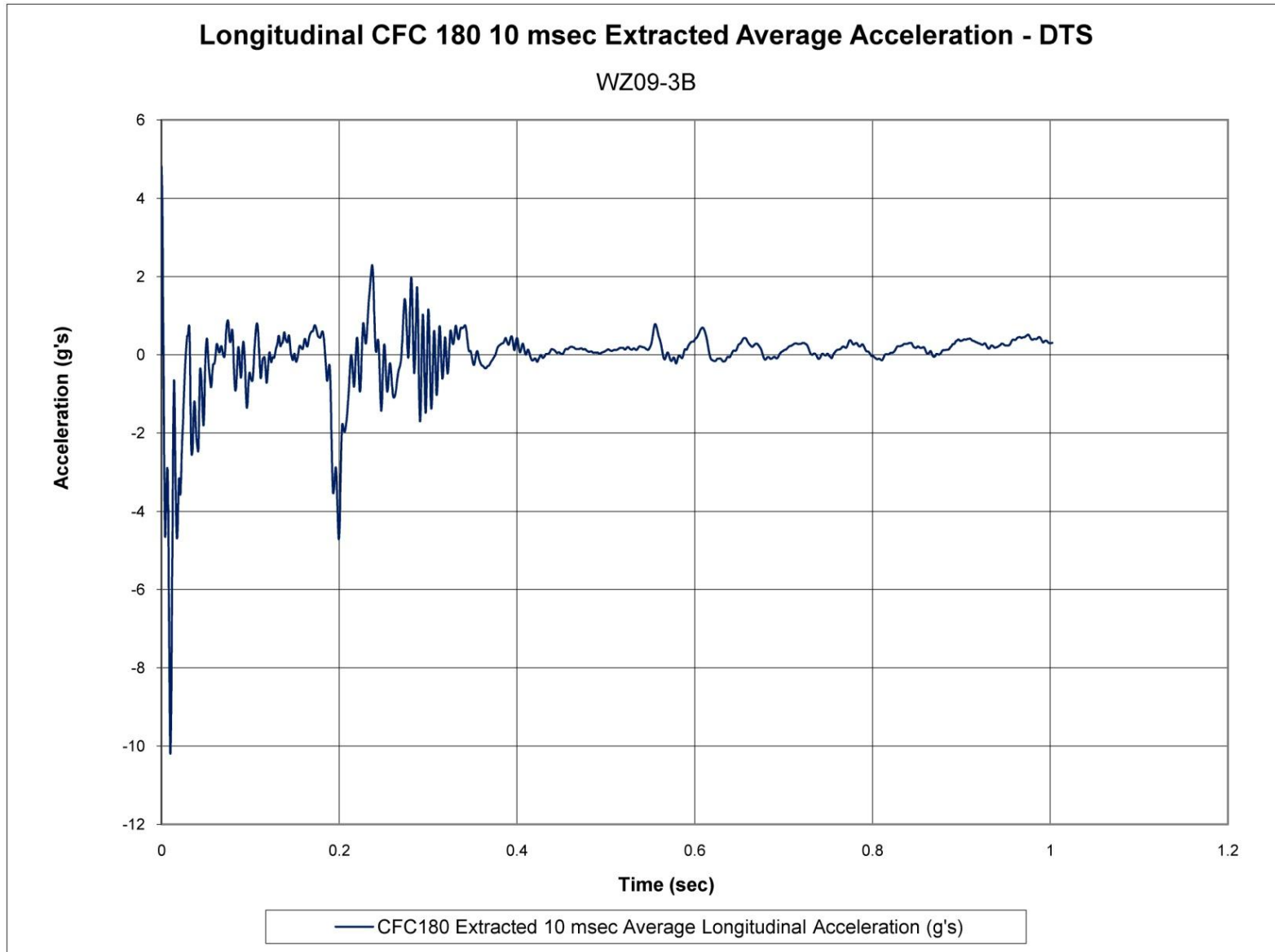

Figure H-20. 10-ms Average Longitudinal Deceleration (DTS), Test No. WZ09-3B

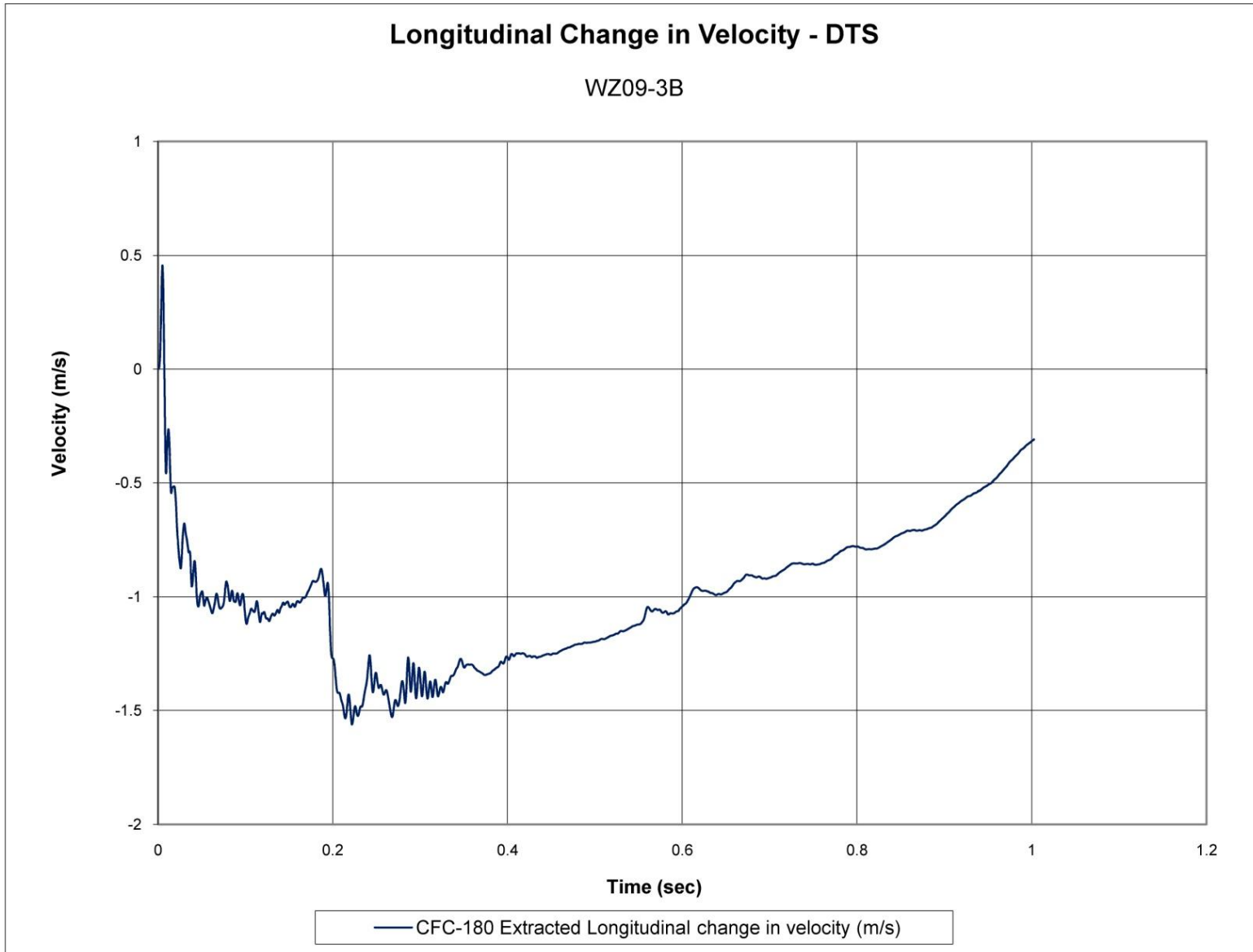

Figure H-21. Longitudinal Occupant Impact Velocity (DTS), Test No. WZ09-3B

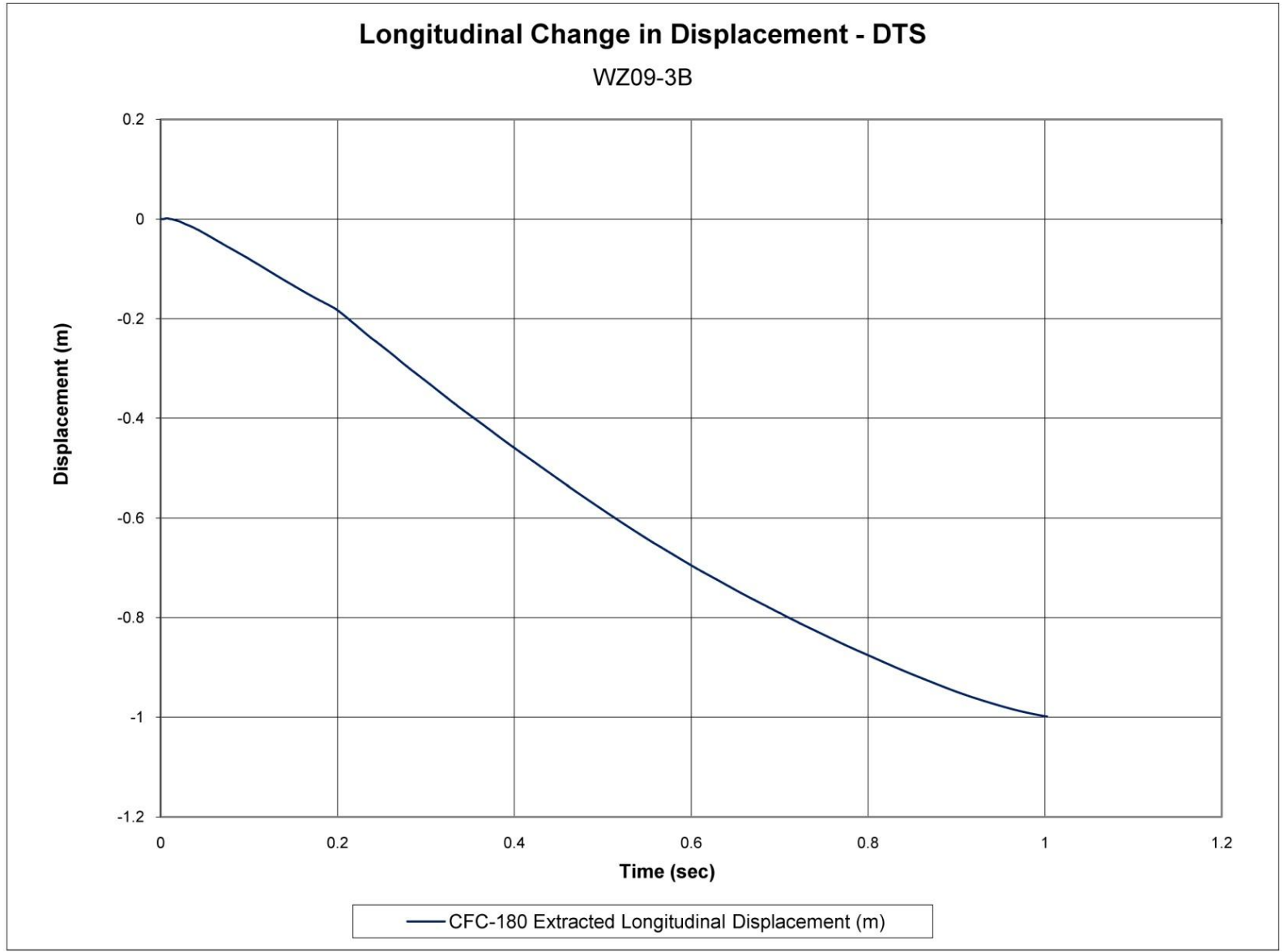

Figure H-22. Longitudinal Occupant Displacement (DTS), Test No. WZ09-3B

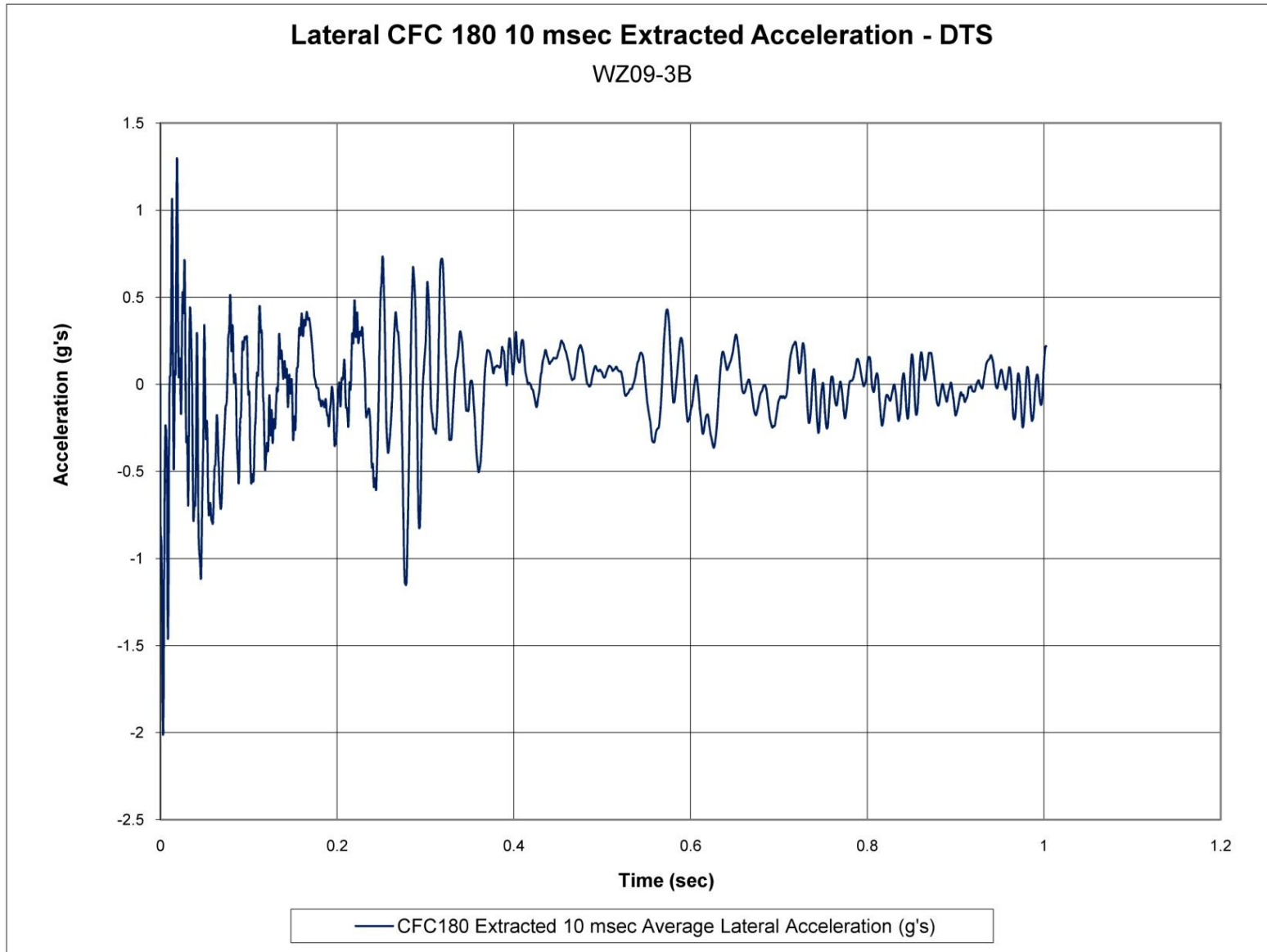

Figure H-23. 10-ms Average Lateral Deceleration (DTS), Test No. WZ09-3B

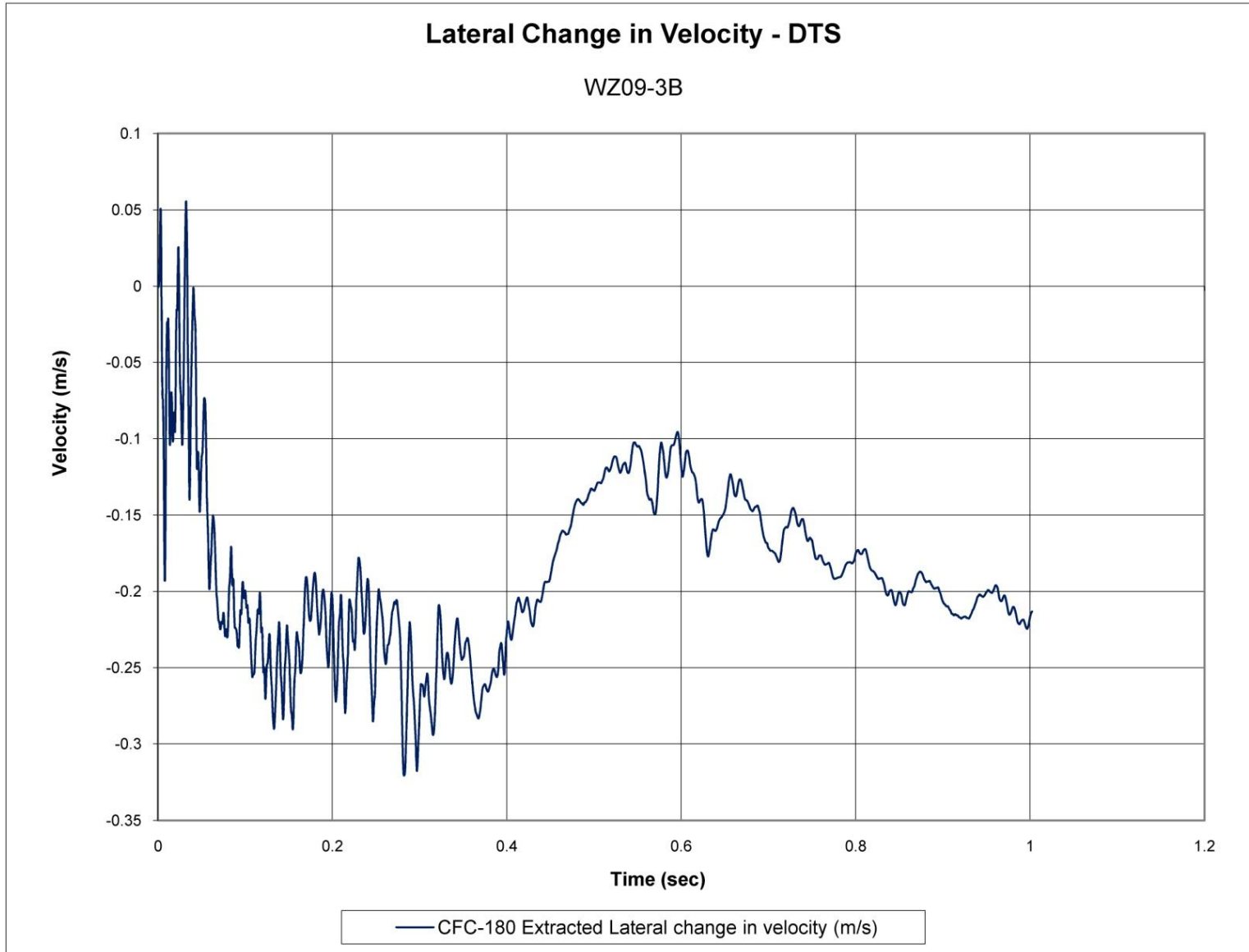

Figure H-24. Lateral Occupant Impact Velocity (DTS), Test No. WZ09-3B

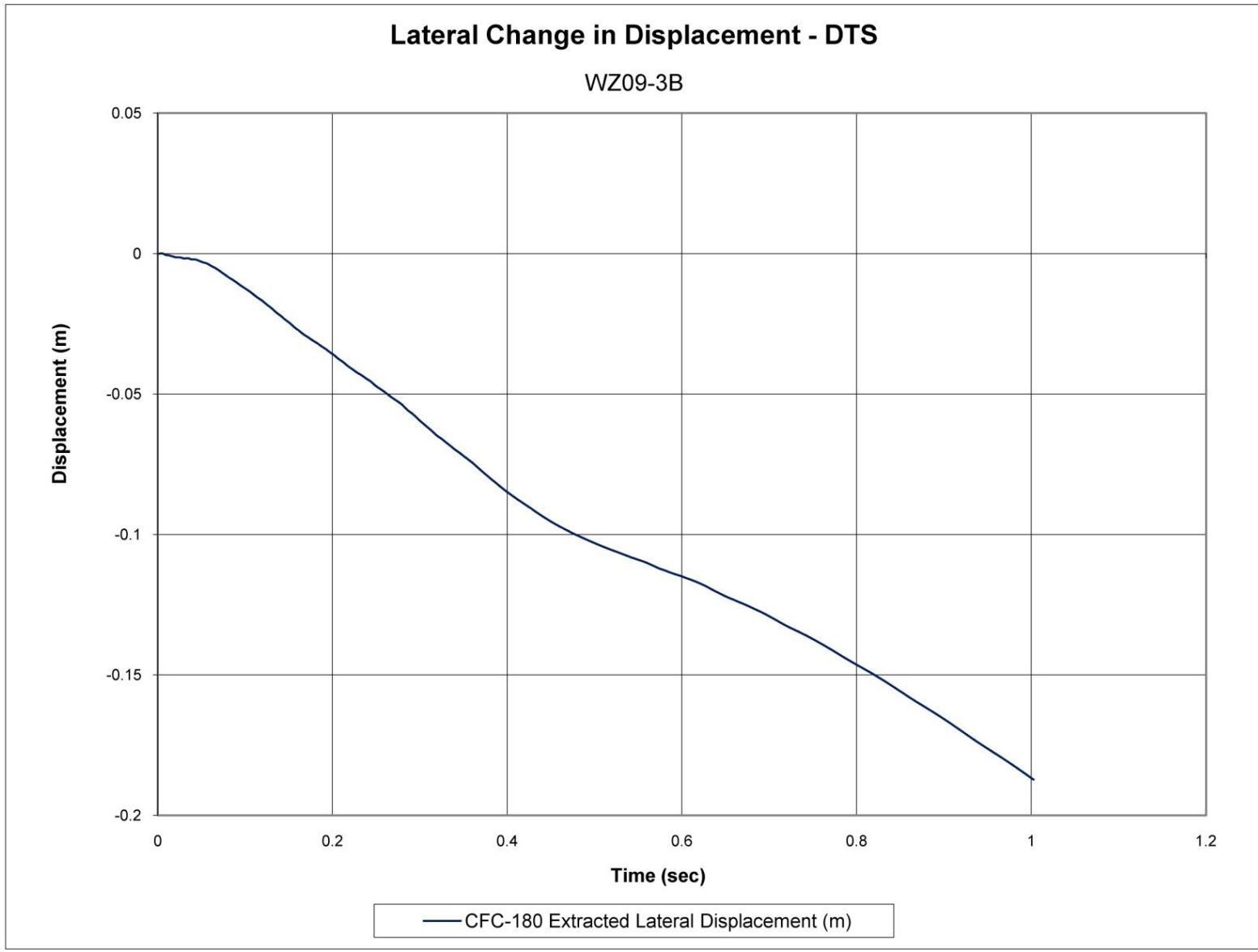

Figure H-25. Lateral Occupant Displacement (DTS), Test No. WZ09-3B

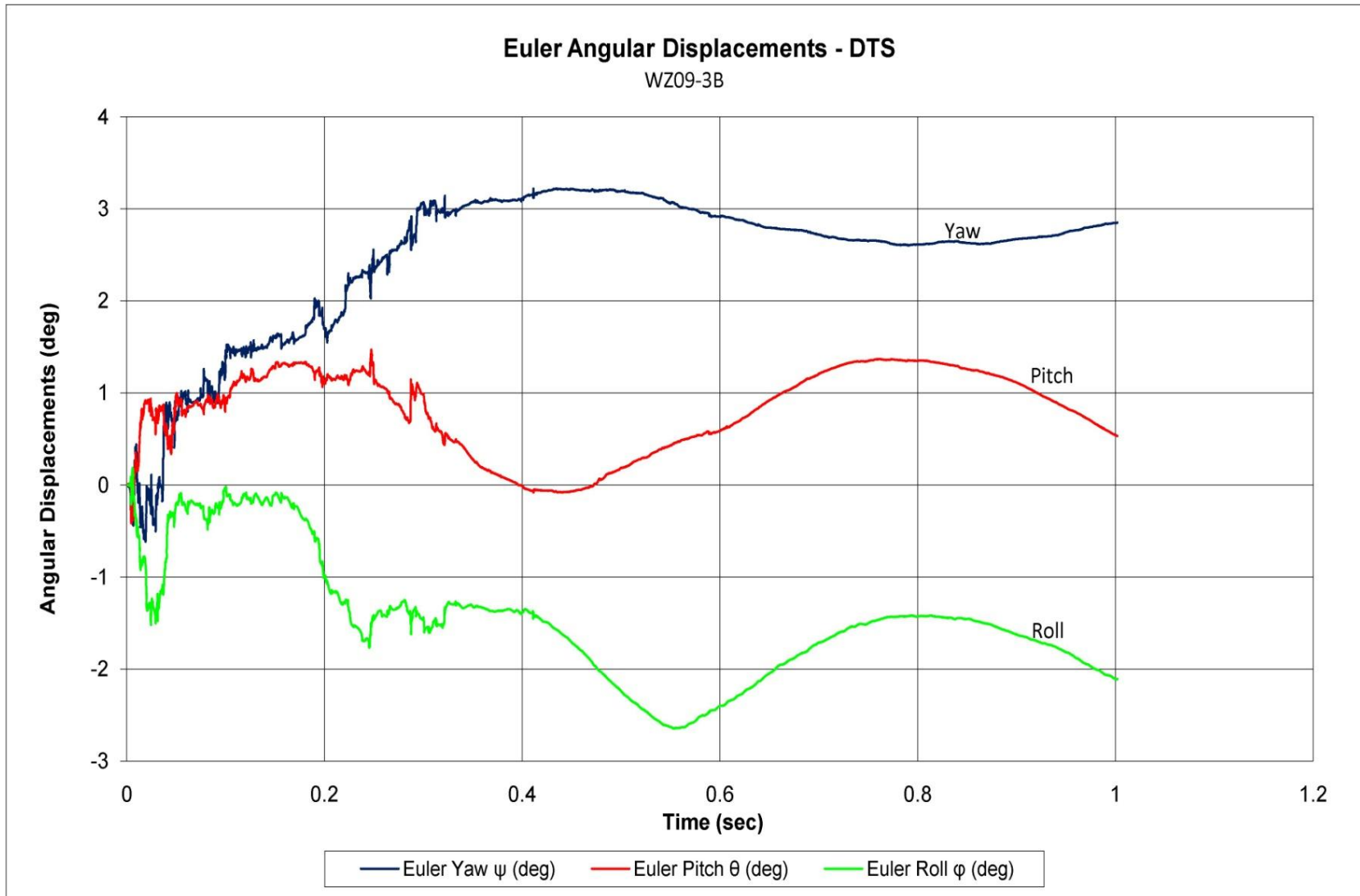

Figure H-26. Vehicle Angular Displacements (DTS), Test No. WZ09-3B

Appendix I. Accelerometer and Rate Transducer Plots, Test No. WZ09-4

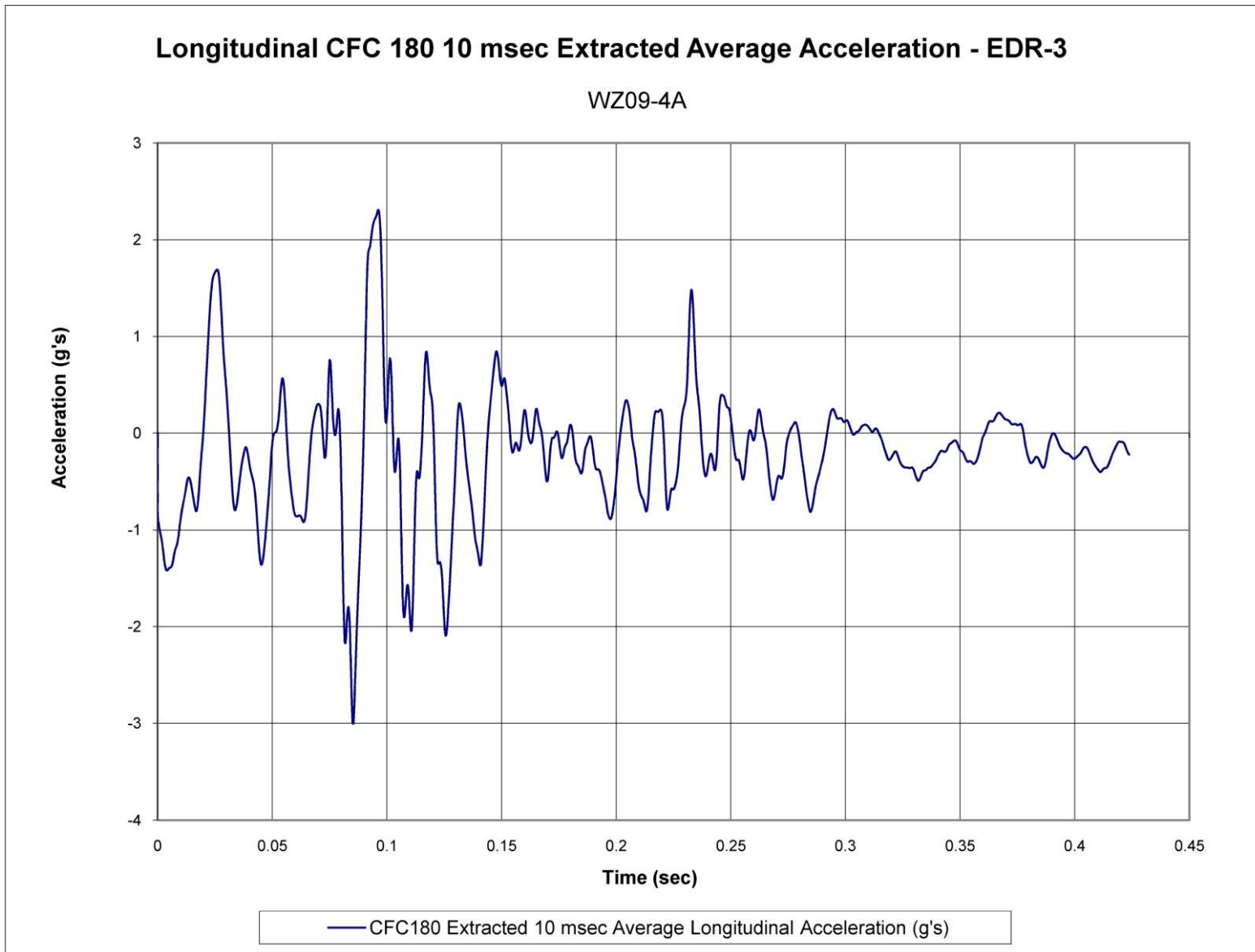

Figure I-1. 10-ms Average Longitudinal Deceleration (EDR-3), Test No. WZ09-4A

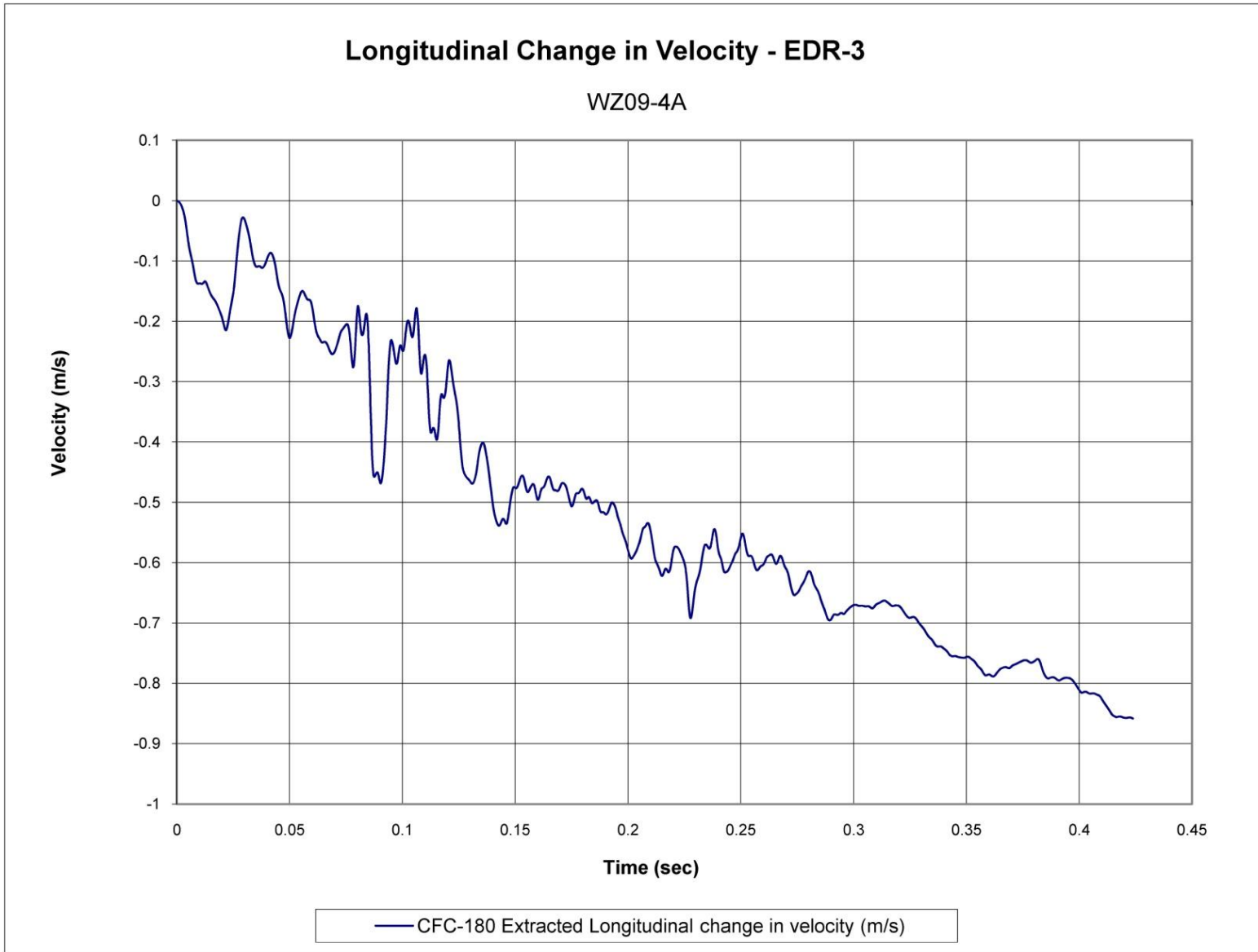

Figure I-2. Longitudinal Occupant Impact Velocity (EDR-3), Test No. WZ09-4A

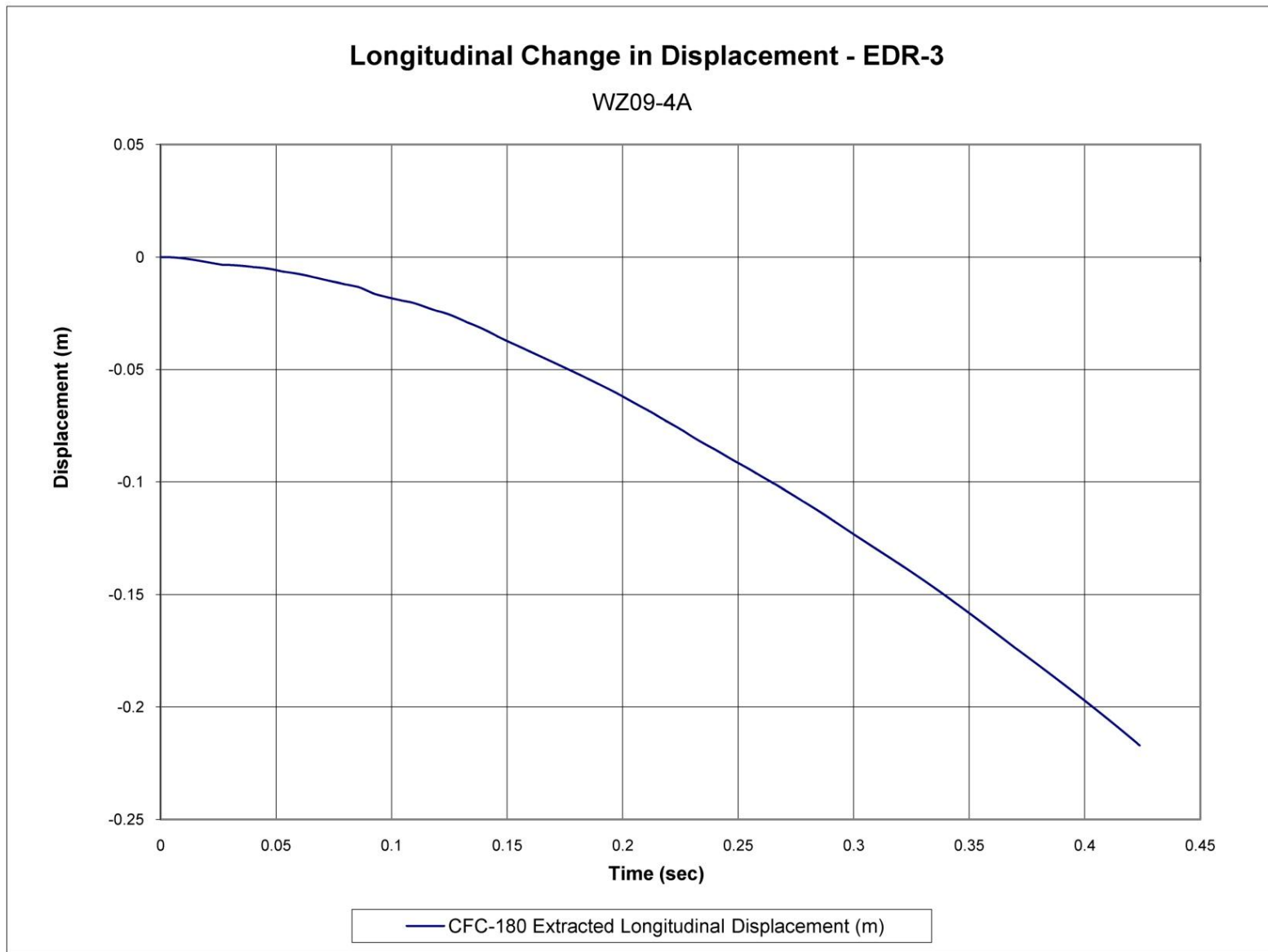

Figure I-3. Longitudinal Occupant Displacement (EDR-3), Test No. WZ09-4A

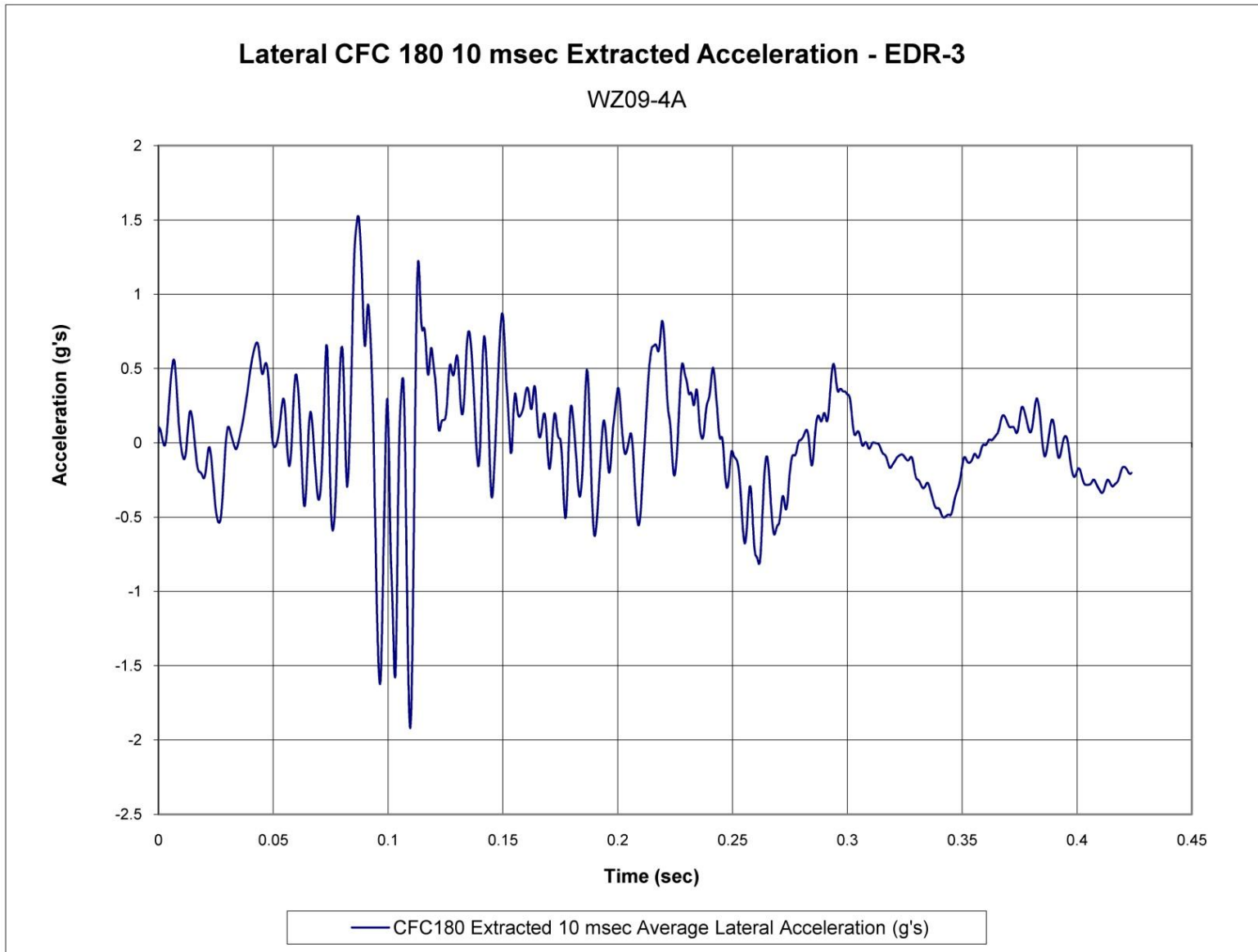

Figure I-4. 10-ms Average Lateral Deceleration (EDR-3), Test No. WZ09-4A

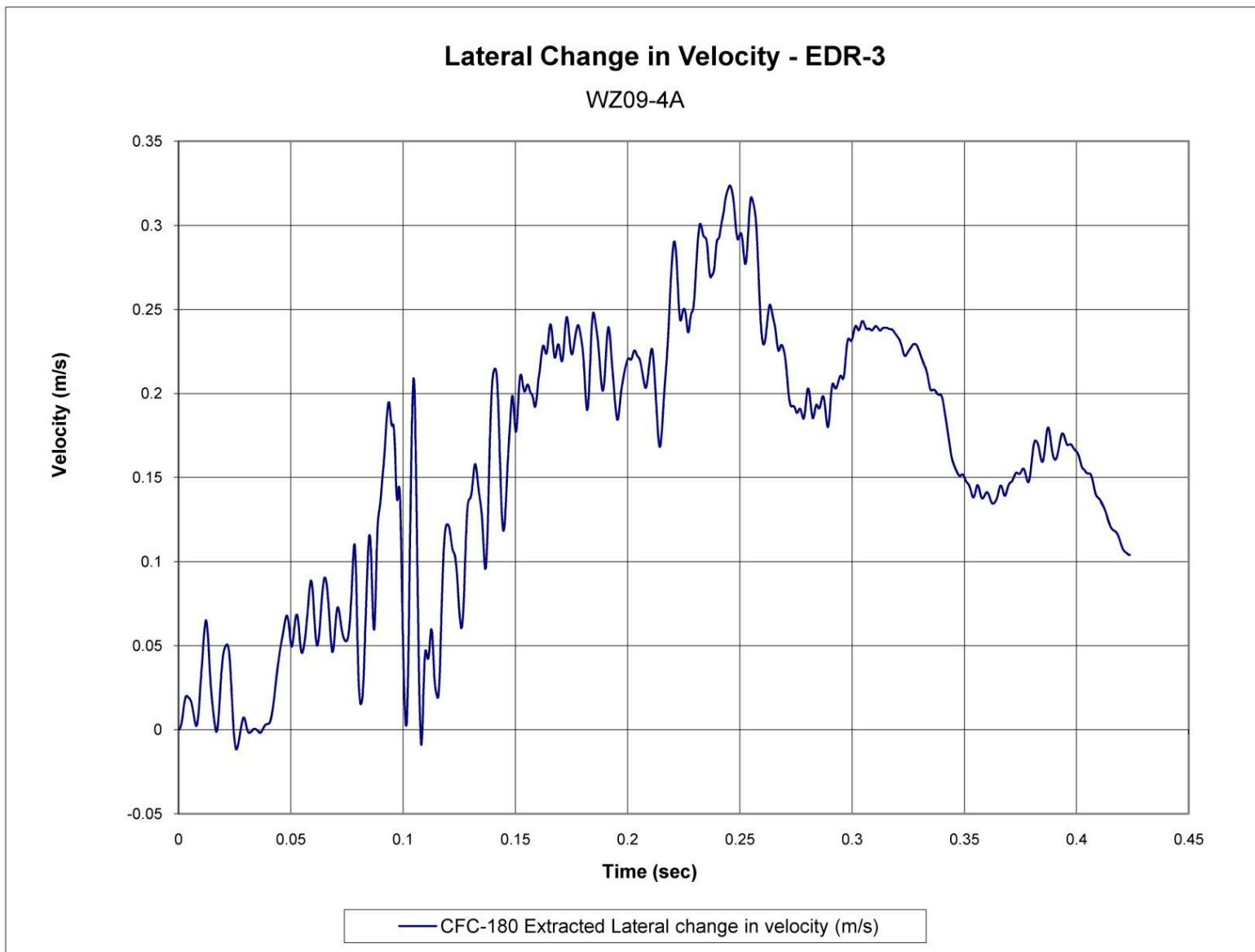

Figure I-5. Lateral Occupant Impact Velocity (EDR-3), Test No. WZ09-4A

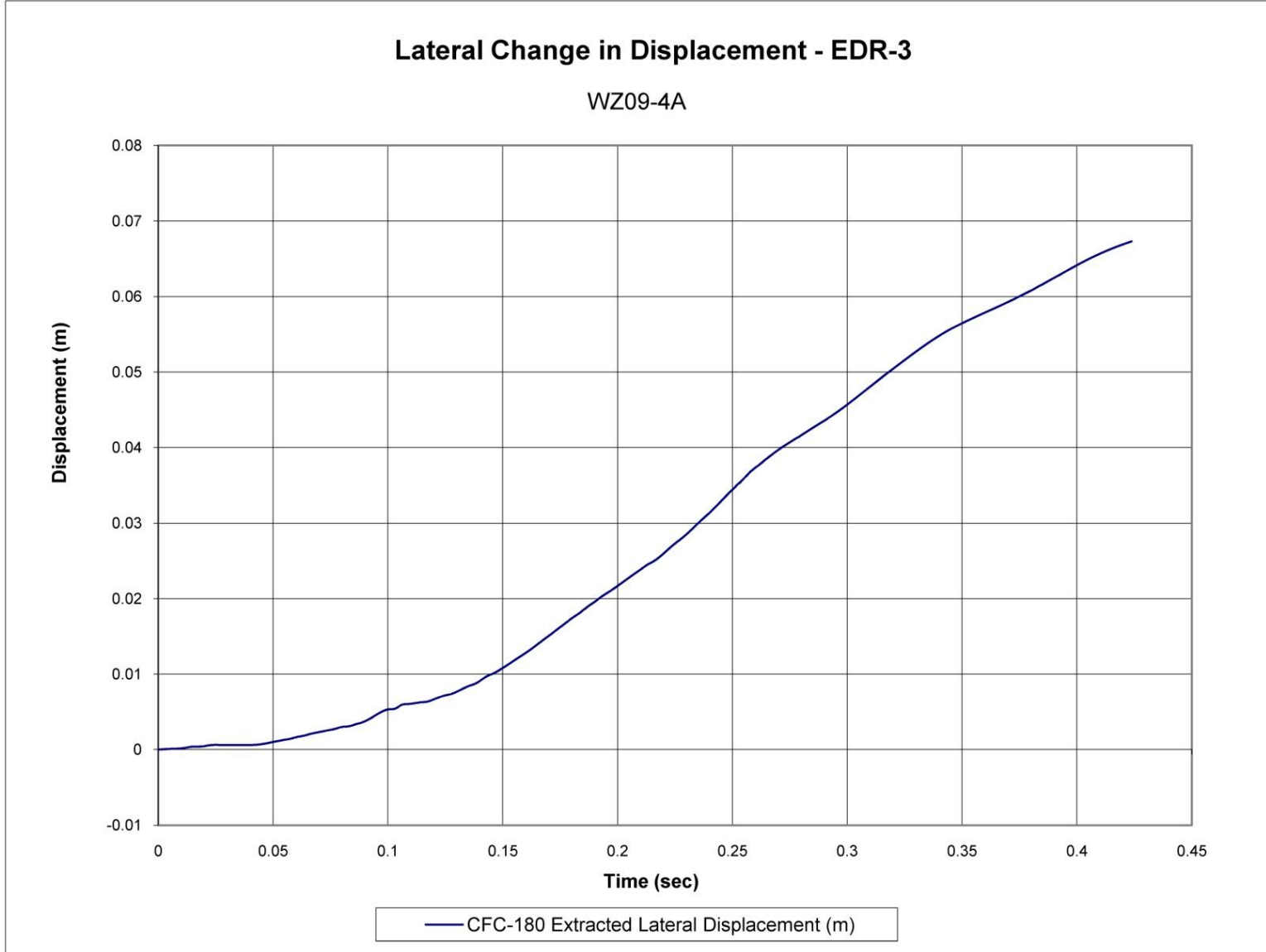

Figure I-6. Lateral Occupant Displacement (EDR-3), Test No. WZ09-4A

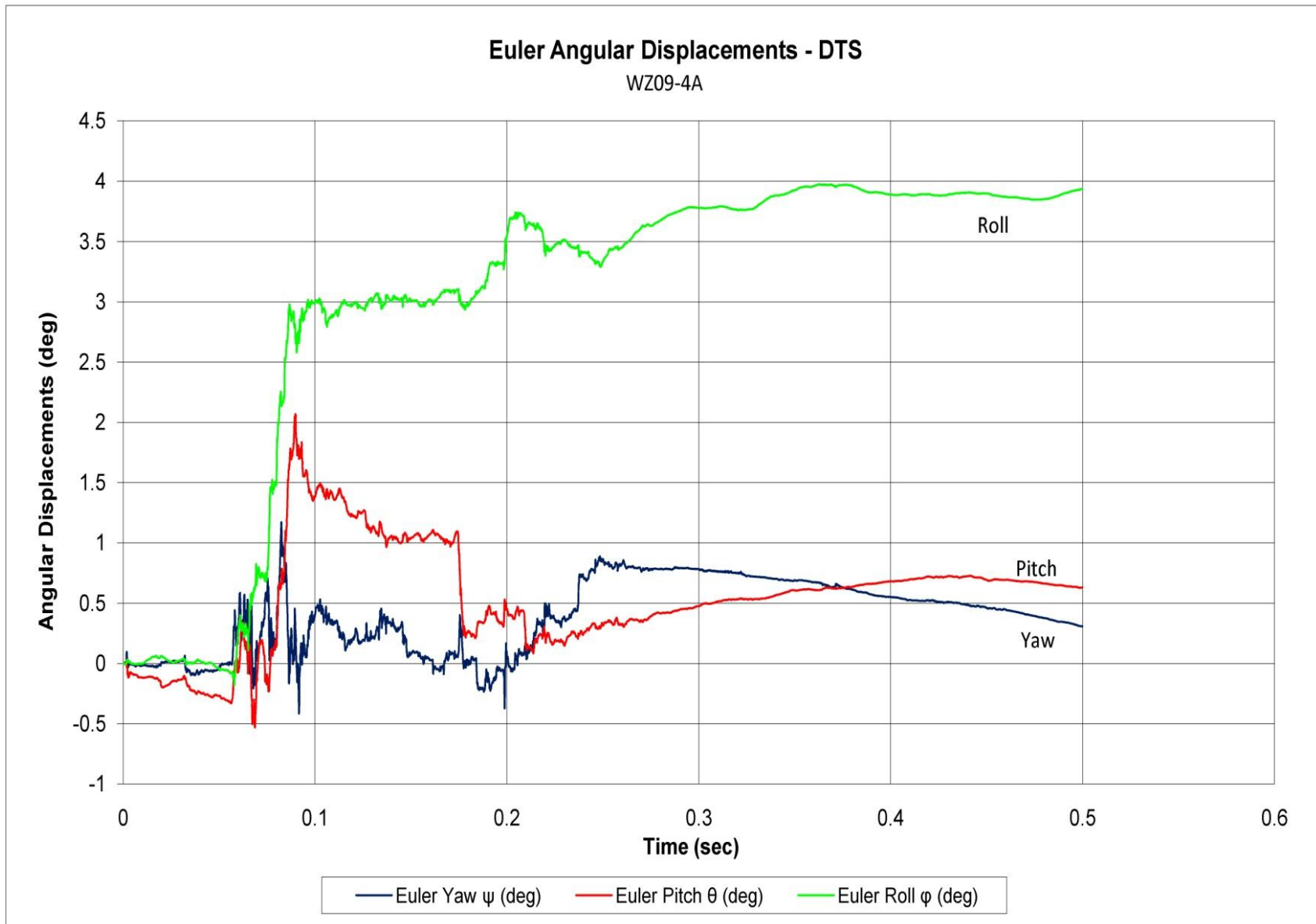

Figure I-7. Vehicle Angular Displacements (DTS), Test No. WZ09-4A

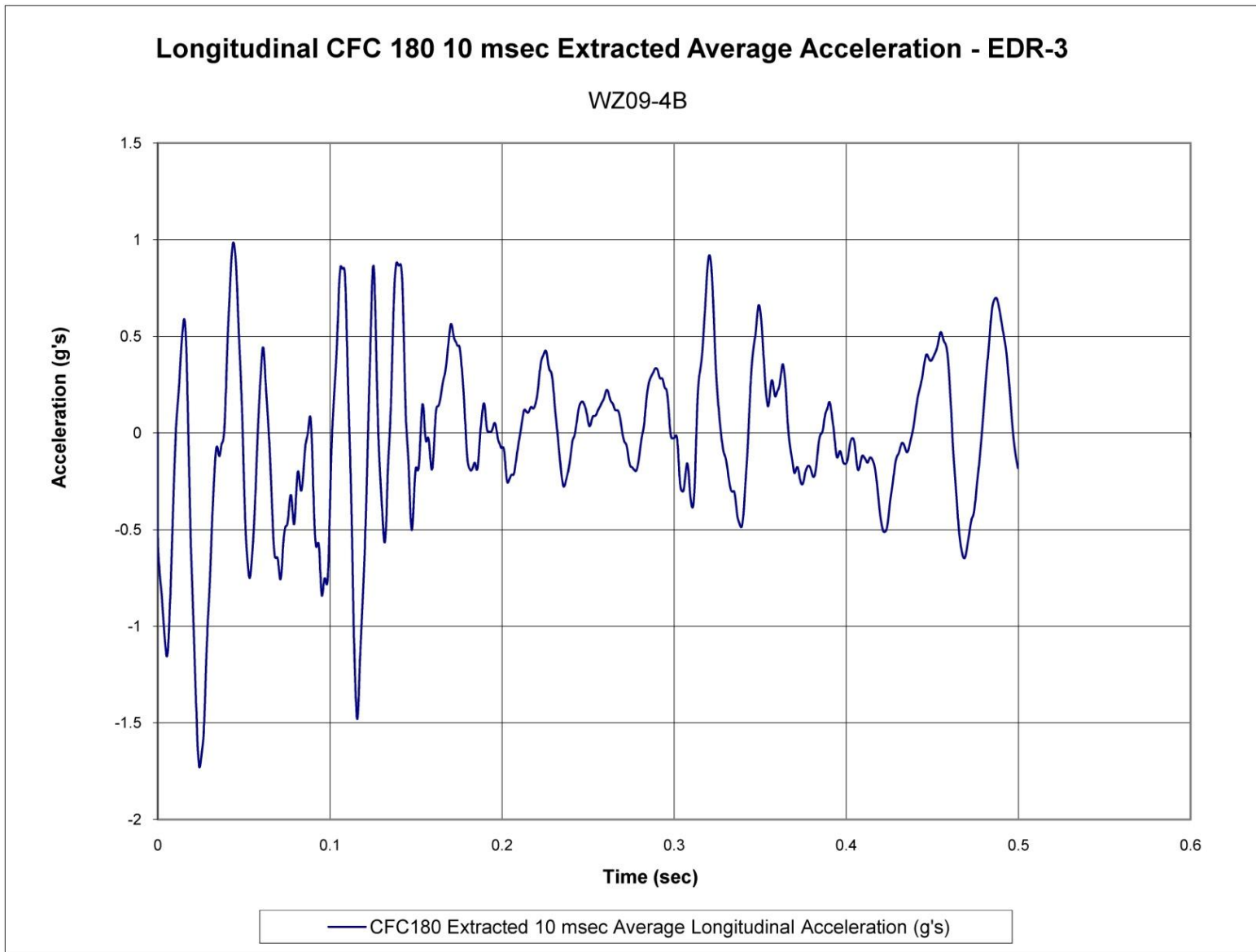

Figure I-8. 10-ms Average Longitudinal Deceleration (EDR-3), Test No. WZ09-4B

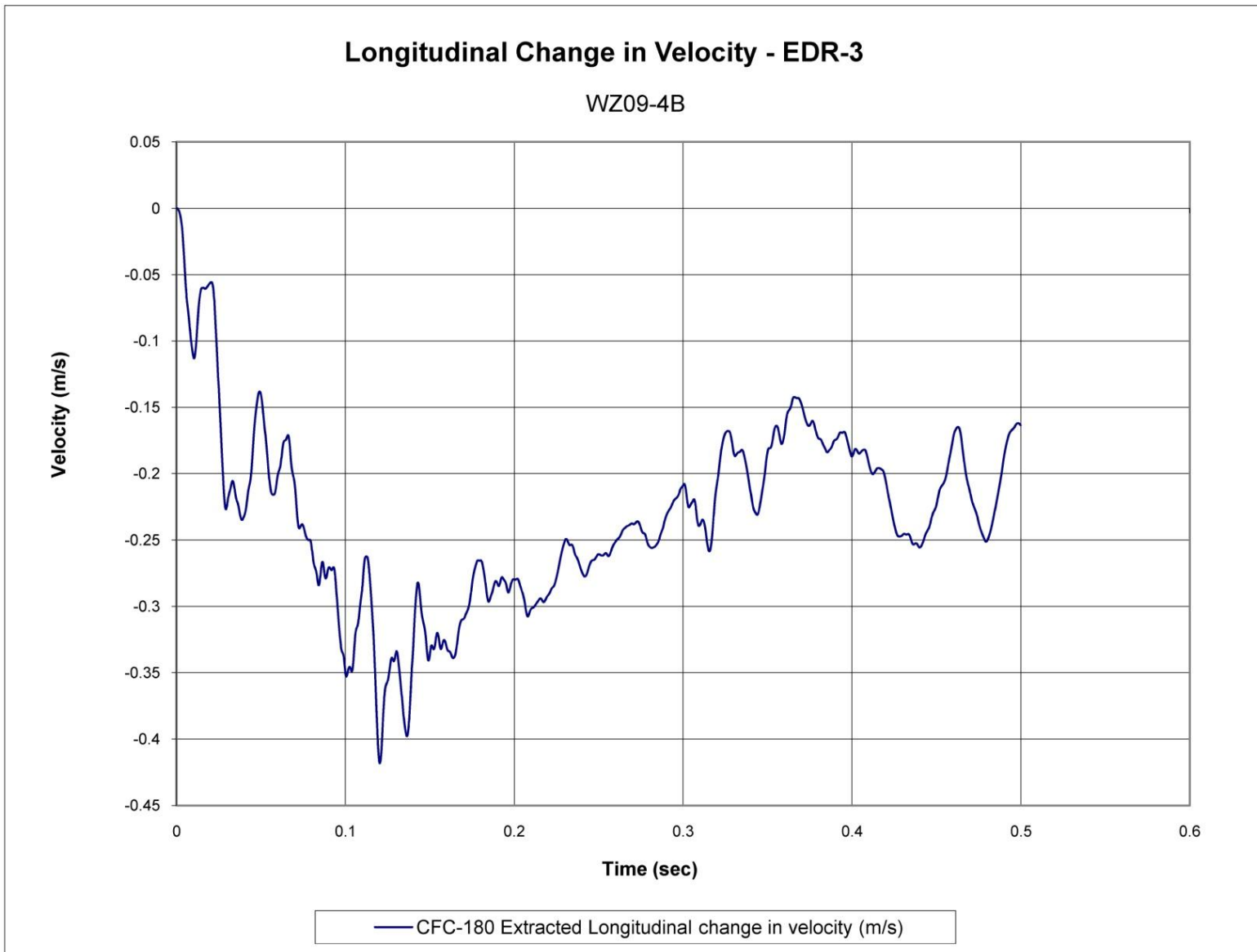

Figure I-9. Longitudinal Occupant Impact Velocity (EDR-3), Test No. WZ09-4B

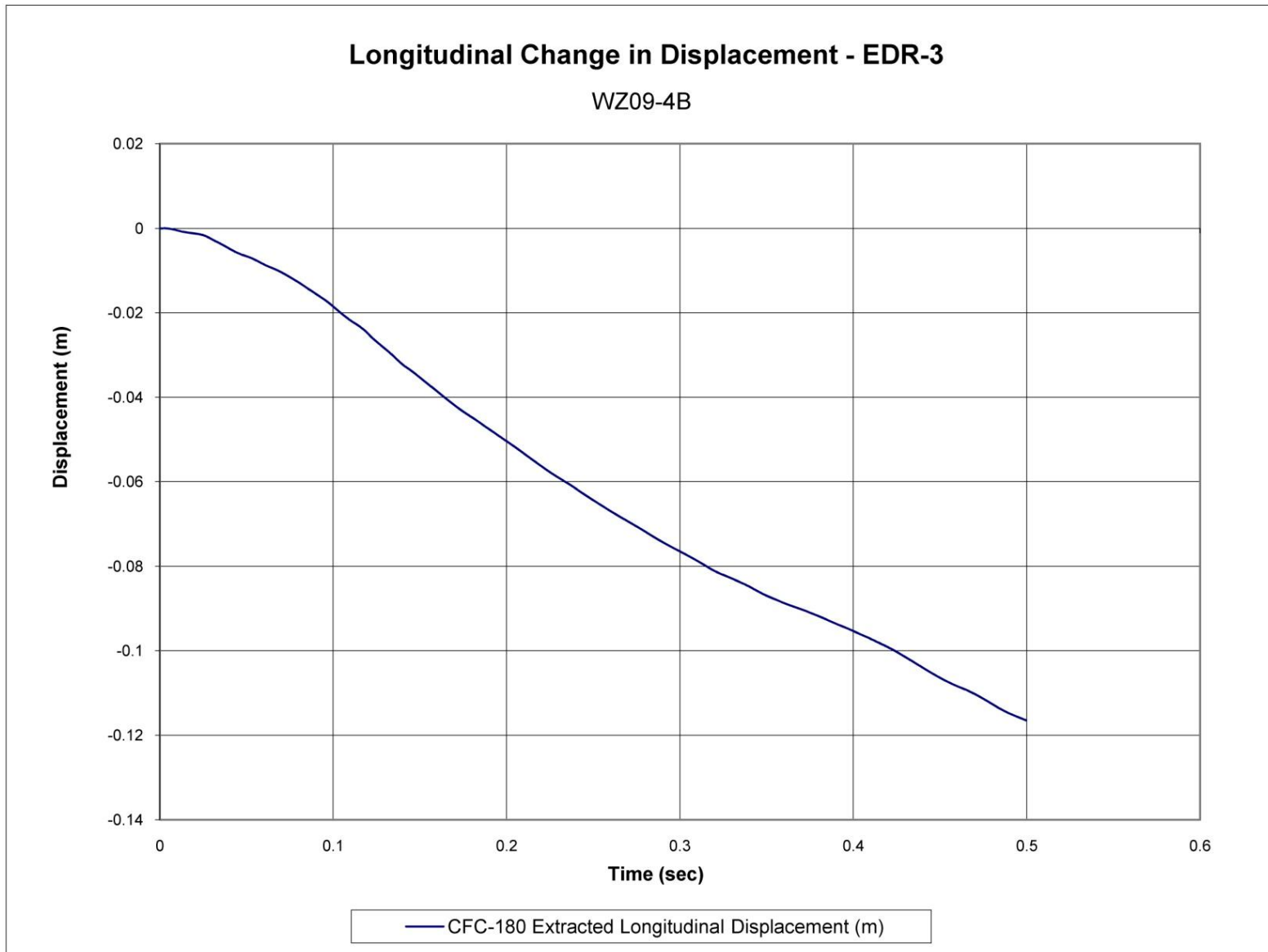

Figure I-10. Longitudinal Occupant Displacement (EDR-3), Test No. WZ09-4B

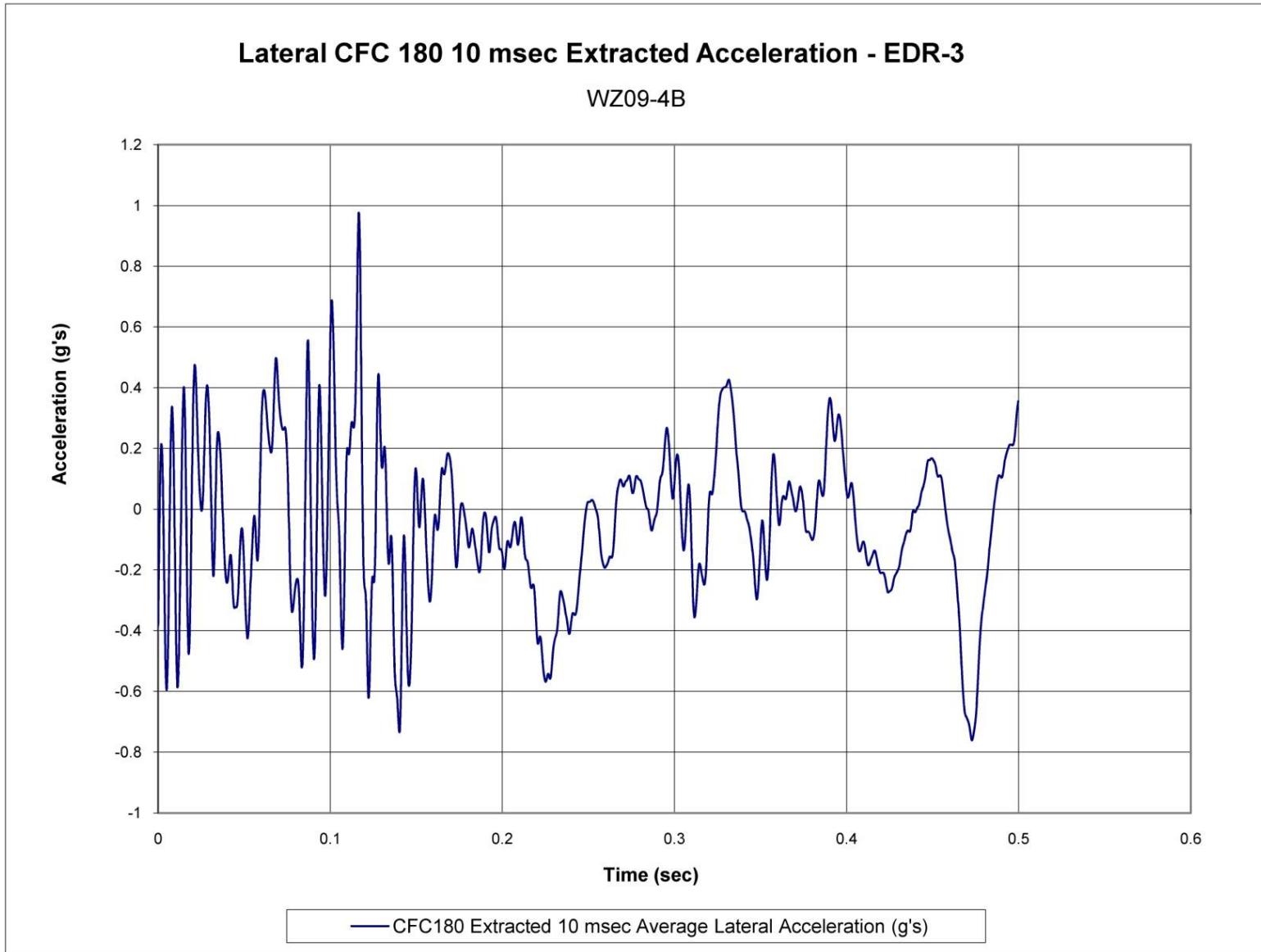

Figure I-11. 10-ms Average Lateral Deceleration (EDR-3), Test No. WZ09-4B

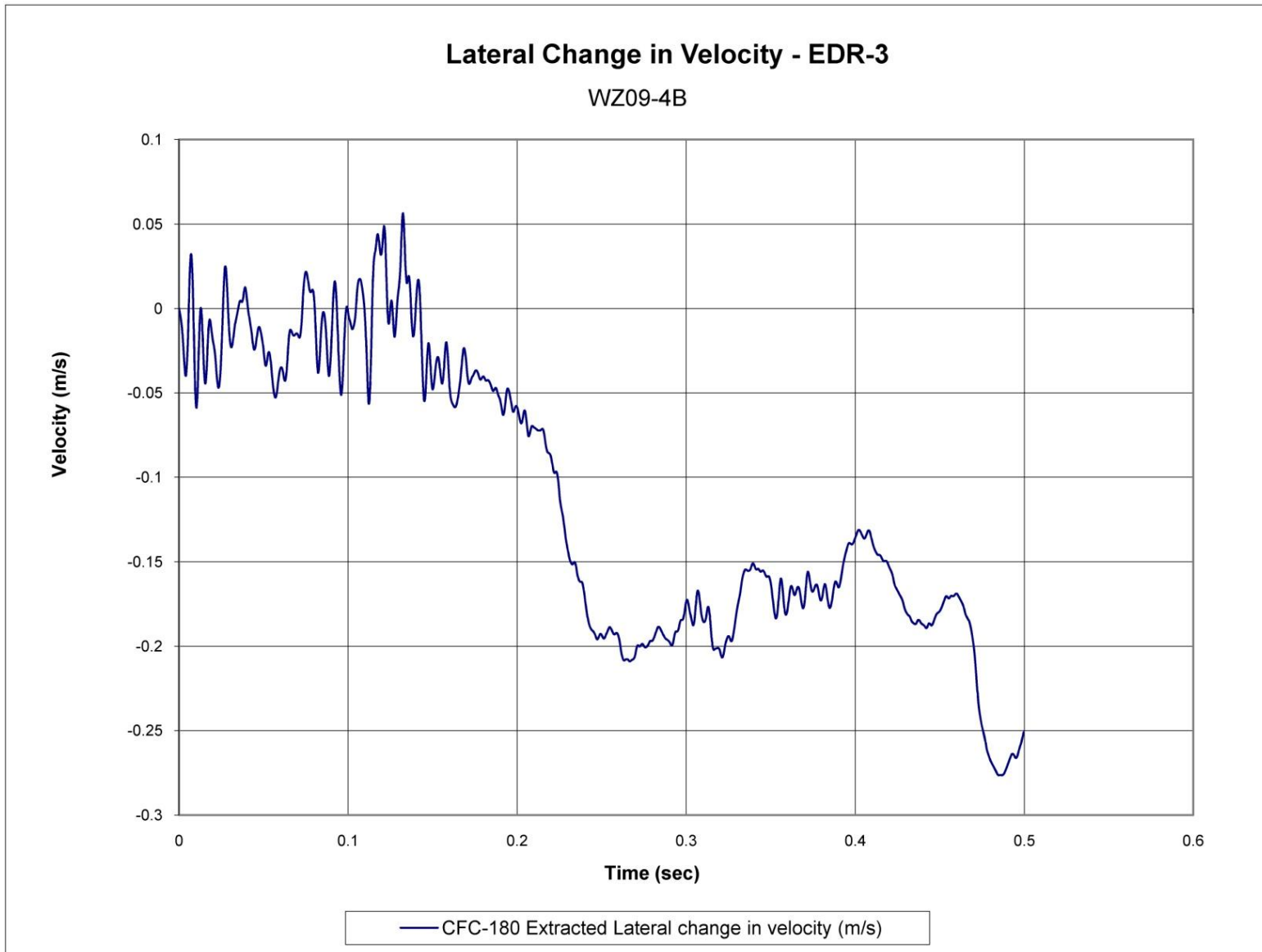

Figure I-12. Lateral Occupant Impact Velocity (EDR-3), Test No. WZ09-4B

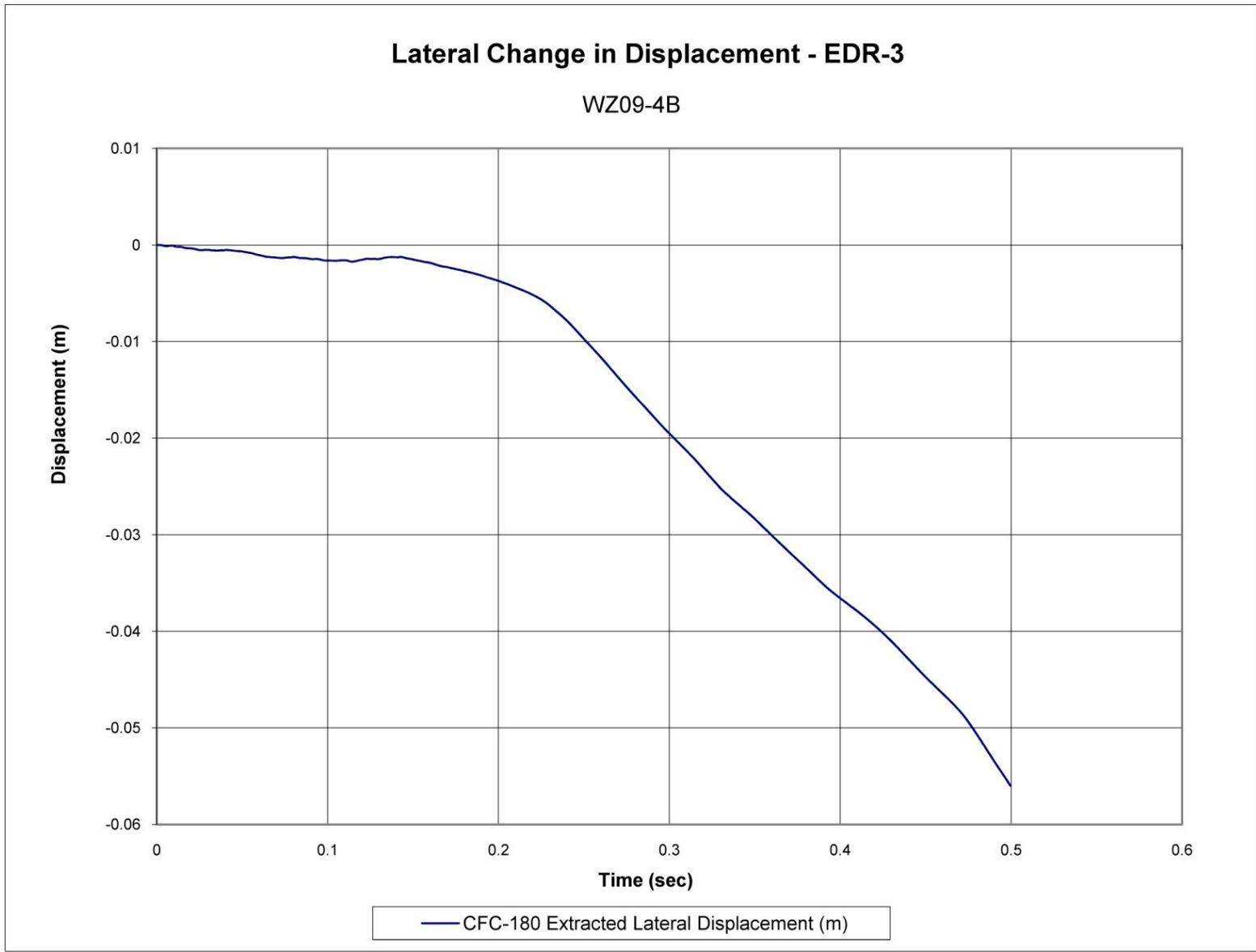

Figure I-13. Lateral Occupant Displacement (EDR-3), Test No. WZ09-4B

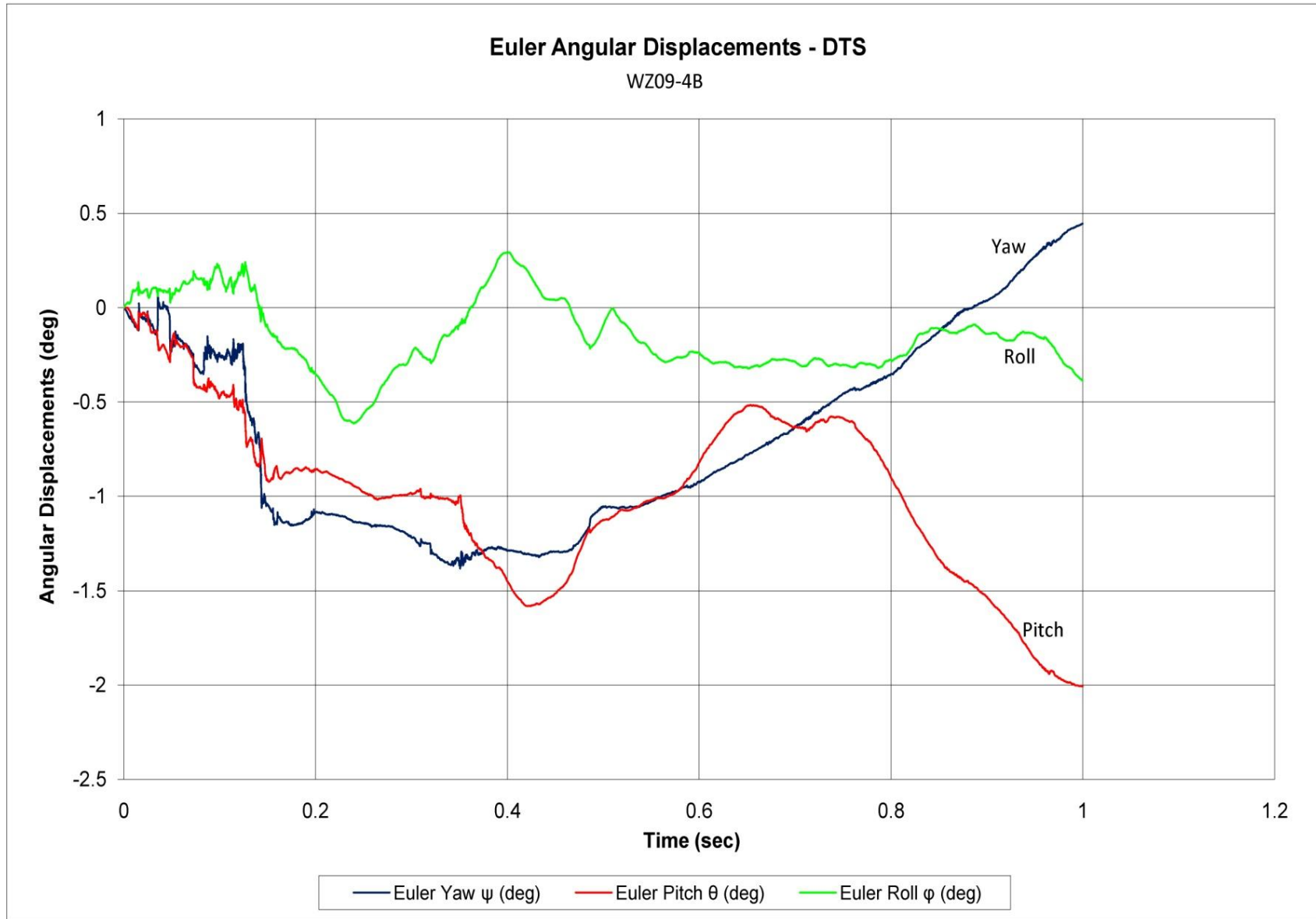

Figure I-14. Vehicle Angular Displacements (DTS), Test No. WZ09-4B

END OF DOCUMENT