



**This electronic thesis or dissertation has been  
downloaded from Explore Bristol Research,  
<http://research-information.bristol.ac.uk>**

*Author:*  
**Daniel, Henry**

*Title:*  
**Dance, performance and technology : a discourse in seven chapters and seven  
choreographic works**

**General rights**

The copyright of this thesis rests with the author, unless otherwise identified in the body of the thesis, and no quotation from it or information derived from it may be published without proper acknowledgement. It is permitted to use and duplicate this work only for personal and non-commercial research, study or criticism/review. You must obtain prior written consent from the author for any other use. It is not permitted to supply the whole or part of this thesis to any other person or to post the same on any website or other online location without the prior written consent of the author.

**Take down policy**

Some pages of this thesis may have been removed for copyright restrictions prior to it having been deposited in Explore Bristol Research. However, if you have discovered material within the thesis that you believe is unlawful e.g. breaches copyright, (either yours or that of a third party) or any other law, including but not limited to those relating to patent, trademark, confidentiality, data protection, obscenity, defamation, libel, then please contact: [open-access@bristol.ac.uk](mailto:open-access@bristol.ac.uk) and include the following information in your message:

- Your contact details
- Bibliographic details for the item, including a URL
- An outline of the nature of the complaint

On receipt of your message the Open Access team will immediately investigate your claim, make an initial judgement of the validity of the claim, and withdraw the item in question from public view.

**Dance, Performance and Technology: A Discourse in Seven Chapters and Seven  
Choreographic Works**

**Henry Daniel**

**A thesis submitted to the University of Bristol in accordance with the requirements  
for the degree of Doctor of Philosophy in the Faculty of Arts, Department of Drama:  
Theatre, Film, Television.**

**July 2004**

**68, 028 Words**

**THESIS  
CONTAINS  
CD/DVD**

University of Bristol, Faculty of Arts  
Department of Drama: Theatre, Film, Television

Henry Daniel

Dance, Performance and Technology: A Discourse in Seven Chapters and Seven  
Choreographic Works

Submitted in accordance with the requirements for the Degree of  
Doctor of Philosophy

July 2004

### Abstract

Technology plays a significant role in influencing contemporary dance and new performance practices. It also helps determine how people gather new information and how they synthesize that information into coherent forms of knowledge. The range of current technological tools allows us not only to access new information but also to support and enhance the processes of dance creation and dissemination, thereby challenging our notions of bodies and the social, cultural and political contexts in which they are perceived. In this thesis, I attempt, as both an artist with an extensive professional background in dance and theatre, and as an academic working within an institutionalized framework, to accommodate and evaluate such work, to frame a different perspective on the situation.

Since many of the issues that characterize contemporary dance and new performance practices do not often fall within strict disciplinary categories and/or conventions, my research argues for a transdisciplinary methodology. I base this argument on the notion that, in an information-oriented age, new kinds of knowledge appear at the intersections of disciplines rather than within them. A transdisciplinary approach to dance, therefore, includes an analysis on the intersection between various forms of knowledge within the discipline and the influence of dance on these forms of knowledge through its presentation of bodies in performance.

As choreography is my primary field of expertise, I created seven works of varying lengths as part of the research. In seven chapters and seven choreographic works, this thesis, therefore, functions as a set of critical and discursive arguments regarding the relationships between contemporary dance, performance studies and new technologies. Finally, it is my intention that this model of practice-led research in dance instigate much-needed new growth in areas of performance practice.



## **Dedication and Acknowledgements**

I would like to acknowledge the guidance, advice and support of my supervisor Dr Günter Berghaus and examiners, Professor Janet Lansdale and Dr Simon Jones, in the preparation of this thesis. I would also like to thank all the performers —; professional dancers and students alike, who contributed to the productions I staged during the research process. To the institutions that provided me with opportunities to explore these ideas, I would like to extend my sincere gratitude, and, finally, I would like to acknowledge the tremendous patience and encouragement my family demonstrated by accompanying me on this extended journey.

### Author's Declaration

I hereby declare that the writing of this thesis was carried out in accordance with the regulations of the University of Bristol. The work is original, except where indicated by special reference in the written text and in the choreographic works presented. The views expressed are those of the author and in no way represent those of the University of Bristol. This thesis has not been presented to any other University for examination either in the United Kingdom or overseas.

All choreographic works and the views they represent are my own, except *Shango Meets Ogun* (1998), which was a collaborative effort with Olugbenga Taiwo. This work was mounted with the help of research funds from King Alfred's College of Winchester, UK. *NU* (1997) was a co-production between ELEKTRODOME of Bristol and HENRY DANIEL AND DANCERS. *Octo 15 '97* (1997) was produced by ELEKTRODOME. *Virtual Illusions* (1999) was a multimedia work conceived by Brian Johnson, choreographed and performed by me, and produced by ELEKTRODOME. *Futurist Equation* (1999) was created with generous help from King Alfred's College, the University of Antwerp, Belgium, and FULL PERFORMING BODIES of Winchester. *Relatively-Well-Centred* (2001) was prepared with the help of a President's Research Grant from Simon Fraser University, Canada. *Out-of-Body* (2002) was choreographed for ZeD, a CBC TV production in Vancouver, Canada. Professor Luciana Duranti of the University of British Columbia in Vancouver and I conducted the interview with performance artist Stelarc in Chapter VII. This interview is part of a case study I conducted for InterPARES 2 (International Research on Permanent Authentic Records in Electronic Systems), a five-year SSHRC (Social Sciences and Humanities Research Council of Canada) research program begun on January 1 2002 and continuing until December 31, 2006.

Signed:.....

Date:.....

## TABLE OF CONTENTS

I.		
Abstract.....		2
Dedication and Acknowledgements.....		3
Author's Declaration.....		4
List of Illustrations .....		9
General Introduction, Methodology and Document Structure .....		10
I. Interfacing Theory and Practice .....		10
II. Formulating a Theoretical Perspective.....		13
III. Dance and Transdisciplinary Knowledge .....		16
Chapter I - Choreography as Discourse, Performance as Research.....		20
1.1 Dance, Language and Transdisciplinary Discourse .....		20
1.2 Word/Movement Interface .....		23
1.3 Semanalysis.....		25
1.4 Languages of Embodiment .....		27
1.5 Choreographing Discourse I .....		33
Chapter II - Recognizing Corporeality.....		39
2.1 "Re-cognition" .....		39
2.2 Lived-ness and Metakinetic Transfer .....		43
2.3 The "Lived" Machine .....		47
2.4 Crick's Search .....		49
2.5 Choreographing Discourse II.....		51
2.6 Some Conclusions .....		57
Chapter III - Artifice and Intelligence.....		60
3.1 Homo Faber.....		60
3.2 AI/AL (Artificial Intelligence/Artificial Life) .....		65
3.3 Intelligent Machines .....		68
3.4 Embodying Information, Embodying Life.....		71
3.5 Choreographing Discourse III.....		74
Chapter IV - Choreographing Discourse .....		77
4.1 Re-cognizing Memory.....		77
4.2 Paradoxical Bodies .....		81
4.3 Dislocated Bodies .....		84
4.4 New Diasporic Bodies.....		86
4.5 Crossing Bodied Cultures .....		88
4.6 Facing West.....		91
4.7 Creativity and Embodiment: Structuring Performance .....		94
4.8 The Pythagorean Interface .....		98



Chapter V - Modernity, the Body and Technology.....	101
5.1 Connecting Histories and Practices .....	101
5.2 Marinetti and the Futurists .....	103
5.3 Meyerhold, Constructivism and Biomechanics .....	109
5.4 Laban and the New German Dance .....	113
5.5 Oskar Schlemmer and the Bauhaus .....	119
5.6 Some Additional Conclusions.....	126
Chapter VI - The Body in Crisis .....	130
6.1 The Body in Crisis .....	130
6.2 Cybernetics, Cyberspace and the Cyborg .....	131
6.3 Dance, Technology and the Crisis of “Abstraction” .....	135
6.4 Conclusion: Towards the Post-Human, Stelarc the Cyborg .....	141
Chapter VII - Archiving Memory: Techno-Spiritual Bodies and Radical Performance Art.....	148
7.1 An Interview with Performance Artist Stelarc (Duranti & Daniel, 2002) .....	148
Postscript.....	172
References.....	174
Composite Bibliography .....	181

## II.

DVD - “Choreographing Discourse” - *NU, Octo 15’97, Shango Meets Ogun, Virtual Illusions, Futurist Equation, Relatively-Well-Centred & Out-of-Body.*

The DVD “Choreographing Discourse” forms an integral part of the thesis “Dance, Performance and Technology: A Discourse in Seven Chapters and Seven Choreographic Works”. By introducing the idea of dance as discourse in my writings, I hope that the choreographic works will speak for themselves. It goes without saying that these pieces are referred to throughout the written part of the thesis. However, my intention is to avoid turning such references into explanations or justifications of the choreographic process, which would only establish the choreographic works as mere documentation for a more “valid” written research exercise. As such, the reader is invited to engage in an active re-cognitive “reading” of both documents as well as the inter-spaces between them. Without this effort by the reader, an important part of the process based on a transdisciplinary methodology will remain unfulfilled.

### DVD Chapters

i. *NU* (1997) Total Time: 00:23:44

1. Start
2. Adrian’s Opening Entrance
3. Henry & Adrian’s Duo
4. Sally’s First Entrance
5. Emma’s First Entrance
6. Henry & Emma’s Duet

7. Sally's Second Entrance
  8. Sally and Adrian's Duet
  9. Emma's Second Solo
  10. Adrian and Sally's Re-entrance
  11. Final Quartet
- Credits

ii. *Octo 15 '97* (1997) Total Time: 00:11:58

This work has the multi-angle feature enabled. Angle 1 features the live performance. Angle 2 features a camera's "motion-capture" recording made for the screen in the studio, accompanied by the sound from the live performance. Angle 3 features a live recording of the work in which the sound "re-choreographs" the dance, made for the screen in a display of movement, colour and graphics.

1. Start
  2. Startup
  3. Break/Detach
  4. Refocus
  5. Resist
  6. Recapture
  7. Constrain
- Credits

iii. *Shango Meets Ogun* (1998) Total Time: 00:22:07

This work also has the multi-angle feature enabled. Angle 1 features the live performance at the John Stripe Theatre. Angle 2 features the motion-capture footage of Shango in the place of the unborn, an "inter-space" between his status as a human being and that of an Orisha. This footage appears simultaneously with the live performance on the DVD, but was projected into the live performance space at intervals.

1. Start
  2. Ogun's Call
  3. Shango's Response
  4. Hanging
  5. Transformation
  6. Judgement
  7. Ogun's terror
  8. Orishas
- Credits

iv. *Virtual Illusions - A slide show* (1999) Total Time: 00:01:29

1. Play slideshow
- Credits

v. *Futurist Equation* (1999) Total Time: 00:40:51

1. Start
2. The Future
3. Conception
4. Progress?
5. Child-Parent Solo
6. The Mass

7. Drugged Dream
  8. Nightmare
  9. Trapped
  10. Reflection
  11. Finale
- Credits

*vi. Relatively-Well-Centred* (2000) Total Time: 00:22:13

This is the third work on the DVD that utilizes the multi-angle feature. Angle 1 features the work's premiere at the Mainstage Theatre at Simon Fraser University. In this performance, one of the video projectors was inadvertently disabled, preventing the music, recorded with the video track, from functioning. The dancers performed the entire work without the benefit of these facilities. Angle 2 features the sound track from a subsequent performance when the media functioned properly.

1. Solo/Group Introduction
  2. Vic's Entrance
  3. Angie's Entrance and Duet
  4. Lisa's Re-entrance and Solo
  5. Lisa and David's Duet
  6. Sara's Entrance and Trio
  7. Monica's Entrance and Quartet
  8. Vic's Re-entrance
  9. Vic and David's Duet
  10. Angie's Re-entrance and Duet with Vic
  11. Group's Reintroduction and Closing Dance
- Credits

*vii. Out-Of-Body* (2002) Total Time: 00:04:26

Vancouver rock-and-roll musician Bif Naked introduces Stelarc and me. Stelarc was also featured on the March 23 show at Zed, but his contribution to the evening's program is not reproduced here.

1. Introduction
  2. The Door
  3. Loss and Absence
  4. The Price
- Credits



## List of Illustrations

Fig. 1 - Messiaen's Seven Modes of limited transposition.....	54
Fig. 2 - Messiaen's Second Mode with transpositions.....	55
Fig. 3 - Taoist Symbol.....	59
Fig. 4 - Laban's Three-Dimensional Planes I.....	118
Fig. 5 - Laban's Three-Dimensional Planes II .....	119
Fig. 6 - Figure in Space with Plane Geometry and Spatial Delineations.....	123
Fig. 7 - Man as Dancer.....	124
Figs. 8-11 - Means of Transforming the Human Body by the Use of Costume.....	124
Photographs	
Figs. 12-14 - Costumes for the <i>Triadic Ballet</i> .....	125

## General Introduction, Methodology and Document Structure

### I. Interfacing Theory and Practice

The distinction between theory — the effort to grasp something whole in order to reflect on it, as if from the outside — and practice — the experiential engagement with something as if from the process of doing it — retains some utility only if reflection and experience are not treated as separable acts but as two interconnected moments of the same activity (Martin, 1998:5).

Computer-based digital systems are irrevocably changing the way we perceive, interact with and represent the world we live in (McLuhan, 1994). Although technology has always played a leading role in the theatre as an instrument for the creation of illusion and the enhancement of dramatic action, the extent to which this influence has increased in recent years is quite remarkable. The modern computer is so entrenched in the planning, production and dissemination of content in all forms of contemporary theatre that it is difficult to imagine a theatre of the future without it. This thesis, therefore, looks at the impact of technology on artistic performance, utilizing different concepts of body to explore an expanded notion of the machine-human interface.

The perspective of the dance artist as scholar is the starting point for these investigations. Relationships between theory and practice, therefore, assume an important focus throughout the document. As an artist, my studio practice consists of choreographing bodies, often using a range of media from video and ultrasonic sound and motion sensors to motion capture technology, in live and recorded performances in conventional theatre environments, site-specific situations, television and the Internet. As a scholar, I interrogate the issues surrounding these activities, contextualizing the work of others who have contributed to the disciplinary discourse, and challenging some of their analyses. The seven works presented here, therefore, constitute an effort to locate the choreographic process at the centre of a practice-led<sup>1</sup> approach to research.



The research methodology, therefore, stresses the centrality of processes surrounding the creation and dissemination of the choreographic work, and a prioritizing of activity over archival data (Schechner, 2002). Three factors are important here. The first of these is intention. Generally speaking, most professional choreographers do not approach their work as an academic thesis. Once a work forms part of the requirements for an academic degree, a significant difference in intention and approach colours the process right through to the final results. Intention is, therefore, a crucial issue in building a research methodology.

The second factor that influences the research methodology is the notion of processing. This refers to the process of creation, how it is set up, implemented and modified within the creative space of the studio and then transferred onto the performance stage. This process is important because collapsing the physical and/or conceptual boundaries between these two spaces inevitably produces radical changes in movement vocabulary, performance style, content framing, presentation tools, audience types, possibilities for interaction, etc.

The third and last factor is contextualizing, which refers to how artists locate their work in relationship to other disciplinary activities and/or forms of knowledge. The critical framework for the research therefore, develops partly out of processes of discovery, as the artist moves between the stages of intention and contextualizing. Since the artist is often in the midst of discovery during these processes, the critical framing occurs *after* the work is done. However, since choreography is a framing of body movements as concepts and ideas within a perspective that an audience can understand and appreciate, a kind of conflict takes place between two fundamentally different approaches to researching knowledge. I argue that a new space or a different possibility exists at this interface, one that promises to reveal new knowledge and/or creative forms.

In the spirit of this challenge, I have included in this thesis the entire transcript of an interview with the performance artist Stelarc. This interview was the initial source material for a case study I led for the InterPARES 2 project.<sup>2</sup> My purpose here is to provide a strong counterpart to the intentions, processes and modes of contextualizing in my own practices, and to provide a connection to the main arguments in the thesis from a more contemporary perspective. Stelarc, therefore, epitomizes a dialectic

between the practices of mainstream contemporary dance, the new practices in the field of contemporary performance art and technology and some of the more historical practices presented in other parts of this document. The two outcomes of my research, i.e., the thesis containing the interview of Stelarc, and the DVD “Choreographing Discourse”, constitute a dissertation on relationships between dance, performance and technology.

The seven choreographic works that comprise the DVD, *Octo 15'97* (1997), *Shango Meets Ogun* (1998), *Virtual Illusions* (1999), *Futurist Equation* (1999), *Relatively-Well-Centred* (2000—01) and *Out-of-Body* (2002), were not designed to function as a performance repertoire. Rather, I conceived them as research tasks, research vehicles, and research outcomes. The process of getting them onto the stage was, therefore, as important as the “final” performances. Altogether, a degree of re-purposing, revisiting and reshaping of issues and content affected all seven works. The method of presentation, i.e., the interactive DVD, offers the viewer/reader a chance to experience the process-oriented nature of the research through cross-references between the “chapters” within a work, other works on the DVD, and those in the public domain.

For example, one can compare the motion-capture footage in the studio version of *Octo 15'97* to its multi-angle format on the DVD, or one can compare its repurposing in a different context to *Shango Meets Ogun* or *Out of Body*. One can also contextualize this use of motion capture sequences in Bill T Jones’ *Ghostcatching* (1999) or Merce Cunningham’s *Biped* (1999). This strategy of creative referentiality through repurposing data also applies to the movement vocabularies between different works as well as to the music and sound scores in other works on the DVD. Thus, while “raw” footage or structural ideas may be similar in places, their use in different contexts results in new layers of information. This technique encourages new sets of connections, thereby suggesting additional critical frameworks or disciplinary contexts in which to view the works.

This tendency to arouse other disciplinary interests is a distinct feature of working with technology, which, because of the central role of computers in gathering, processing and redistributing information, influences the acquisition of knowledge in general. Part of my intention as the author of this thesis is to create an interface between certain assumptions and newly emerging perspectives. This strategy appears



throughout my writings as well as in the “chapters” of the seven choreographed works. The aim is not to frustrate my readers, but to challenge their understanding of the phrase “interfacing theory and practice”.

## **II. Formulating a Theoretical Perspective.**

A central idea in this thesis is that new developments in technology increasingly drive the production of knowledge and direct cultural change (Kimbell & Perry, 2001).<sup>3</sup> As such, the performing arts, dance in particular, need to set new challenges. This study contributes to a trend in dance and performance scholarship that repositions that scholarship towards a broader transdisciplinary perspective, one that accommodates the increasingly wide range of interests in the body as the focus of performance actions. Thus, practice-led research involves not only creating dances and performance works that are discursive and critical in their own right, but also stimulating debate and critical dialogue about issues important to a wide public. The seven works that form part of this thesis are not conceived as justifications for theoretical positions, nor does the written thesis seek to explain what the choreographic works mean. Rather, both documents co-exist in a symbiotic relationship; they share and extend a transdisciplinary discourse on dance, performance and technology, and they should be “read” as such.

Since technology has today become a primary tool for creating, organizing and disseminating information, and since the human body has always been the model for society’s institutions and organizations, the notion of a machine-human or computer-human interface assumes great importance in both the written and choreographed parts of this thesis. Technology has always been associated with the efficient running of a machine and/or a set of tools that facilitate such efficiency. I argue that the technological is a mode of operation whereby people synthesize processes into techniques and tools, which, over time, become institutionalized as part of society’s collective cultural memory. Thus, focusing attention on the development of new forms of technology can be regarded as an attempt to influence cultural evolution. My effort to create a critical framework for this thesis is, therefore, based on the understanding that individual bodies exist in a reflexive relationship with larger institutional and impersonal bodies, i.e., academia, politics, society, etc., that we, as human beings, make contact with in our daily lives and/or through our creative endeavours.

The mediation of our actions through technology has always formed an integral part of humanity's socio-cultural and bio-evolutionary history, and the idea of a machine-human interface has been explored before in different ways. We project our contemporary aims externally in the tools we produce (Heidegger, 1962), the institutions and structures we build (Lyotard, 1984) and the cultural patterns and communication processes we establish (Deleuze & Guattari, 1983). Science and culture, therefore, reflect a deep connection to technology. Since our institutions, with their bureaucratic structures, and our artistic productions, with their choreographed structures, are together expressions of an extended body, a number of different interfaces exist where we exchange, transform and transmute information of one sort or another. Thus, when I refer to the "machine-human" or "computer-human" interface in this thesis, I use the term in both the conventional and conceptual senses to problematize notions of human agency, consciousness, intelligence and awareness in relation to a broader and more complex socio-cultural, political and administrative entity. If, as I am indeed suggesting, human beings can project their awareness into or across other systems or structures, a "machine-human interface" can exist anywhere within this extended body.

This approach makes it quite difficult to formulate a critical framework grounded in any single theory. Instead, this thesis draws on a variety of disciplinary perspectives that have the potential to focus on a particular field of activity, namely performance, and to address the behaviour of bodies, whether institutional, personal or disciplinary, from such a perspective. Hence, the focus is transdisciplinarity as a strategic approach to understanding the interests that disparate disciplines express in the body and technology as relationships of performance. Century (1999), Gibbons (1994), Andersen (2000), and Scholz, Klein, et al. (2001) cite a range of perspectives on transdisciplinarity and the new knowledge economy that has proved useful to this investigation. The most important of these is that transdisciplinarity incorporates perspectives from broad networks of knowledge and cultural production that include all areas of science and technology. With its interpenetration of disciplinary epistemologies, transdisciplinarity can be extremely useful in the examination of intersections between disciplines. Scholz, Klein et al. (2000) claim that transdisciplinarity is designed to support the solution of complex problems in society



by incorporating the ideas of its stakeholders from the fields of science, politics and industry.

My approach to transdisciplinarity in this thesis amounts to a tool to help reposition the performing arts, and dance in particular, as stakeholders within the new knowledge economy. As such, I will identify a role that performance can play in understanding cultural evolution, especially in societies in which new knowledge often depends on how well new technologies “perform”. Currently, every new piece of technology results in concomitant creative practices that expose deep ethical, social, political and cultural issues. Because of this, a new kind of evolutionary activity is taking place at the machine-human interface, manifesting itself in individual and institutional practices that generate a variety of perspectives on bodies. With virtual embodiment as a possible scenario for future machine-human co-existence, there is a strong requirement for dance artists to reconsider the role that their body practices play in an increasingly technological world.

Like the industrial revolution of an earlier era, today’s digital revolution reflects the aims and achievements of a society obsessed with technological innovation. Technology influences our cultural life, plays an important part in the structural orientation of our public and private institutions, and enters into our business transactions. An example is the city of Seattle in the United States, which has developed key goals for what it believes a technologically healthy society should be.<sup>4</sup> These goals include viewing technology as a way to 1) enhance the local economy, 2) solve social problems, 3) promote relationship building and community development, 4) foster civic participation, and 5) sustain the quality of life through equitable and affordable technological tools.

The study that ultimately identified these key goals found that 76% of Seattle residents had access to home computers and each spent an average of 28 hours per week on them. One fourth of this total time, i.e., seven hours, was spent on the Internet. The report proudly claims that “Seattle residents find computers to be very useful for a wide -range of communication, work, and research-related tasks”.<sup>5</sup> My point in introducing these statistics here is not to dwell on the production and distribution of technological resources in a business community connected through technology, but to draw attention to technology’s potential to create, generate, shape, sustain and perhaps

also destroy cultural life. My aim is also to identify transdisciplinarity as both a theoretical approach and a critical framework for my arguments.

### **III. Dance and Transdisciplinary Knowledge**

Dance has been described as an embodied practice that manifests how movement can momentarily concentrate and elaborate in one place forces drawn from beyond a given performance setting (Martin, 1998). Martin uses this definition to argue for a politics of dance, defining politics as the “forces that devise and differentiate the social world” and that ultimately influence the individual’s ability to act (Martin, 1998: 3-5). Two types of performance are implied here: one with a socio-political dimension, another with an aesthetic dimension. Helen Thomas (1995), citing Hanna (1979) on the inability to separate the dance from the dancer, claims that the key to understanding sociology’s neglect of dance lies in Western culture’s perception of the body, namely “privileging the rational”, i.e. thought over the emotional, i.e., the corporeal (Thomas, 1995: 6). Thomas also argues that this attitude serves to exclude the body from language and discourse.

Since this thesis follows a transdisciplinary definition of performance as discourse, one that explores different notions of a machine-human interface, my methodology also incorporates perspectives drawn from political and sociological readings of the body. However, at the core of this analysis is the re-examination of the phenomenological notion of “lived” experience. The research I conducted claims that since we have access to a phenomenologically constituted and extended socio-cultural body, we can learn to recognize and perhaps reconfigure its experiences in new and more meaningful forms. Since the performer’s art is to engage and enhance the audience’s attention through the power of performance, the role that attention plays in the dynamics of the performer/spectator relationship becomes very important.

Also important is the trend to simulate these processes with new technologies. The point here is that many of the new technologies are specifically designed to capture the individual’s full sensory attention and to convince him or her that what is occurring is truth and can be believed. The intention is to engage the viewer and the object of the gaze in a symbiotic relationship, establishing a link between the two that is energetically alive and felt as a presence. This study argues that we invest technology with a particular meaning because of the attention we lavish on it. Consequently, we



depend on technological systems as modes of communication and information processing as well as a means of creating and disseminating cultural capital.

The position of this thesis is that we are technologically mediated creatures, i.e., our thoughts and actions are mediated by new technologies. Thus, we can no longer use terms like “intelligence”, “life”, “consciousness”, “awareness”, “mechanical” and “technological” without conjuring up challenging notions of what exactly differentiates the machine from the human. Since we are linked to the world via our bodies and the memories of our bodies’ activities, our notions of existing in time and space are increasingly influenced by our attitudes to this machine-human or computer-human interface. This research, therefore, examines dance and performance practices as modern vehicles for the recovery and analysis of collective memories, which we, with the help of technology, shape into new cultural visions of the future. It also argues that embodying and disembodying practices from this past are more closely related to contemporary cultural activities than we commonly acknowledge.

Recent studies show that children have trouble reading and comprehending because of the types of media they are exposed to: many play sophisticated video games before they learn to read and/or write properly.<sup>6</sup> There are reasons to believe that our reliance on the written and spoken word for the construction of ideas of self and identity is eroding. The new media uses different strategies to manipulate the basic elements of language, for example. The joystick and keyboard manipulate visual icons, and we now have a universal cut- and- paste approach to manipulating content. Larger than life reality shows and fantastic computer games provide children with their primary source of new experiences. The new media is rapidly changing our sensual experience, or lack of it, of the physical world.

Chapter I of this thesis covers choreography as discourse within the context of a practice-led research strategy. Two prominent choreographers of late 20th-century dance, Pina Bausch and Lloyd Newson, explore dance as a language-like facility for communicating issues in addition to feelings and thoughts. My own choreographic exploration provides a counterpoint in this first chapter. I refer in particular to *NU* because of its use of sound as a structuring device in choreography. Chapter II looks at the “lived” experience of phenomenology in relation to the concept of “re-cognition” as defined later in this research. It draws on different writings in an effort to support

the argument that the performing human body reveals corporeally embodied knowledge of humanity's "lived" experiences. Drawing on the relationships between science, technology, art and philosophy since the ancient Greeks, I attempt to explore dance as a record of relationships between bodies, objects and their environments. Again, the accompanying DVD "Choreographing Discourse", and other choreographic strategies I employed in earlier works, provide important contexts for these arguments. The chapter ends with an explanation of how duality leads to unity through a process of mediation of opposites, a concept that returns in subsequent chapters.

Chapter III is a short interfacing essay that begins with an examination of Max Frisch's *Homo Faber*, a novel whose protagonist relies on science and technology to explain and solve all problems associated with the human condition. This novel sets the tone for the 20th twentieth-century dilemma of how to resolve the split between rationality and emotion. The chapter continues with an examination of British mathematician and computer scientist Alan Turing's famous test for Artificial Intelligence (AI), whose primary aim was to question the concept of intelligence in humans and computing machines. This test identifies another set of issues about the nature of the computer-human interface. Together with Frisch's *Homo Faber*, this other "case study" provides a model of the consequences for the individual and for the scientific and artistic communities as a whole in their quest to explore new interfaces.

Chapter IV looks at the issue of convergence from different perspectives. It begins with an examination of five works from "Choreographing Discourse", namely *Octo 15 '97* (1997), *Shango Meets Ogun* (1998), *Virtual Illusions* (1999), *Relatively-Well-Centred* (2000-2001) and *Out-of-Body* (2002). These works provide a cultural context for a discussion on transdisciplinarity and techno-spirituality as aspects of the machine-human interface. The chapter also looks at different philosophical and cultural perceptions of reality, and briefly examines some artistic works that contextualize these views. It ends by focusing on Pythagoras' contribution to Western knowledge as an example of how certain fundamental ideas within disciplinary areas tend to converge with the use of the principle of mediation, as outlined in Chapter II. Chapter V develops this discussion and explores modernity as a dynamic between a desire for progress through technological innovation and the stability and perspective of tradition. Also discussed is the argument that history repeats and develops basic ideas that have been consolidated through particular institutions and practices. Here, as



in other places throughout the thesis, the reader has an opportunity to refer to my own performance works on the DVD “Choreographing Discourse”. In this context, particularly relevant is *Futurist Equation*, a choreographic debate on the writings of the Italian Futurists.

Chapter VI looks at the idea of the body in crisis examined as a tendency toward disorientation, fragmentation and alienation within society’s extended body through the work of prominent late 20th-century choreographers. Stelarc becomes the focus of my interests after references to works by choreographers Merce Cunningham and William Forsythe. Stelarc is a prime example of the convergence of disciplinary practices in performance. This artist uses technology to enact a contemporary ritual that denies human agency while at the same time betraying a concern for the evolutionary fate of humanity. An interview with Stelarc conducted by Luciana Duranti of the School of Library, Archival and Information Studies, University of British Columbia, and myself forms the basis of Chapter VII. As I mentioned before, the interview is part of a case study I prepared for the InterPARES organization, and its purpose here is to allow the reader an insight into the artist’s ideology, aesthetics and creative processes as well as the rationale behind his unique performance work. It also provides an important counterpoint to my own views on the body, technology and embodiment at the machine-human interface.

## Chapter I Choreography as Discourse, Performance as Research

### 1.1 Dance, Language and Transdisciplinary Discourse

To approach the body as capable of generating ideas, as a bodily writing, is to approach it as a choreographer might. Dance, perhaps more than any other body-centered endeavor, cultivates a body that initiates as well as responds. (Foster, 1995a: 15).

To begin this study, I would like to boldly state an often understated or unacknowledged truth, i.e., that choreography is a discourse that uses the body in performance as its primary means of articulating issues of importance to society and humanity. Dance is, therefore, language-like in its abilities. Next, I would like to outline the discursive positions underlying my main arguments. The first is that through movement the human body generates and expresses complex ideas in a profoundly meaningful way. The second is that practice-led research is a valid methodological approach necessary if this scholarship is to be properly recognized. And third, new models of dance scholarship must emerge to accommodate the complex directions that new knowledge is taking. These positions frame most of the issues this study addresses, those that relate to dance artists as scholars and the nature of their research as challenges to accepted notions of academic scholarship.

In the quotation at the beginning of this chapter, Susan Foster (1995a) implicitly suggests that movement is like a language and that the choreographer bodily “writes” his or her ideas through the choreographic craft. Choreographic inscription occurs as a succession of organized bodily images or movement attitudes that challenge the viewer’s psyche.<sup>1</sup> The act of arranging and performing this material constitutes a unique and powerful form of discursive activity.

**discursive** *adj.* 1. passing from one topic to another, usually in an unmethodical way; digressive.  
2. *Philosophy.* of or relating to knowledge obtained by reason and argument rather than by intuition (*Collins English Dictionary* 1995: 50).

This second quotation provides some interesting definitions of discourse: the words “passing”, “unmethodical” and “digressive” provide a striking contrast to “reason” and



“argument”. The key to this apparent paradox lies, of course, in the different contexts: the first definition is general while the second refers specifically to the use of “discursive” in philosophy. Deleuze and Guattari define philosophy as the search for knowledge of phenomena through “the art of forming, inventing, and fabricating concepts” (Deleuze and Guattari, 1994: 2). Thus, although philosophy defines “discourse” in a specific manner that limits it to a logical activity characterized by the exposition of claims, premises and proofs in verbal and/or written arguments, i.e., linguistically, one can also form, invent and fabricate concepts in other ways.

Deleuze and Guattari also claim that philosophy, art and science each engage in the activity of thought as an act of creation, arguing that the sphere of creation differs in each discipline. Their position is that “art is concerned with the creation of percepts and affects” (Deleuze & Guattari, 1994: 164), i.e., sensations, while science is an activity of thought that creates “functions” which are “propositional”, thus forming fragments from which it pieces together a makeshift language (Deleuze & Guattari, 1994: 117). Art, science and philosophy, therefore, each have a relationship to language that is discipline specific. In other words, individual disciplines define the terms of their relationship to language. Since, according to Deleuze and Guattari, science and philosophy use “concepts” and “functions”, and art “percepts” and “affects” as tools in their pursuit of knowledge, terms like these ultimately limit the discourse that different disciplines can rely on.

My formulation of discourse in a practice-led research strategy addresses movement as the function of bodies, presenting concepts through a choreographic manipulation of movement structures built up around dancers’ identities, body types, gender, race, nationality, cultural background, etc. Even though the choice of material may sometimes appear “unmethodical”, “digressive” and “passing”, a different kind of logic is in fact in operation, one directed by research interests as they attempt to define an original trajectory. Since this latter approach does not always coincide with the conventions of academic and/or philosophical writing, I will attempt to justify why such a strategy is necessary.

The current trend in describing research as the production of new knowledge creates an interesting dilemma for artists and academics alike. In an age when new methods of processing information constantly fuel such productivity, we are witnessing some

unique practices and a range of disciplinary interests that converge at the machine-human interface. New information also appears to emerge more readily at the intersection between disciplines rather than within individual disciplines (Century, 2001; Henagulph, 2000). However, a strong disciplinary perspective is a requirement to transmute new, often abstract information into usable knowledge. Thus, for new knowledge to be produced, supported and integrated into society, we need networks of individuals with expertise in different disciplines.

As a dance artist and scholar, my starting position is the body. As a form of expression and/or communication, dance has its unique internal structures, modes of organization and its own overarching structures of individual movement motifs, phrases, sequences and extended patterns. It “speaks” through bodies whose identities centre on race, gender, sexual orientation, size, shape, colour, culture and origin. The concept of “body” is, therefore, both personal and institutional. For example, we often speak of social organs, of bodies of literature, the arm of the law, the body as a text or as a site for discourse, and of corporate, mental, spiritual and emotional bodies. In ancient Egyptian and Greek architecture, the cubit was a unit based on the length of the human forearm (Lawlor, 1982). The renowned Italian artist and scholar Leonardo da Vinci bequeathed an extensive body of multi-disciplinary work to posterity based on his extensive research of the human body (MacCurdy, 1977). In short, the human body has always played an important role in determining how people visualize their worlds, and how they construct their artefacts, institutions and rituals.

With its ability to choose how to comment on and analyse any aspect of the body, dance can be a powerful mode of critical discourse. Intricately structured or improvised sequences of dance movements can reveal interesting studies in human intention, social action and identity construction. Dancing may not be the best way to argue a position or present a debate, but by generating ideas and responding to them in its own way, dance fulfils some important objectives in terms of understanding the complexities of our human condition.

However, if this new research is forced to conform to old models, it will not yield its potential. To regard dance as bodily writing is a resourceful idea that draws attention to the body’s power to generate ideas, but we must be careful how we proceed to implement this analogy. We cannot conceive of a dance as we would a book or an



essay, even though they provide ideas for generating and structuring movement. We must, therefore, search within the new practices for a new means of analysis. With the body at the core of a variety of issues and debates surrounding our relationship with technology, it is extremely important that dancers, choreographers and performance artists take advantage of the roles they can play in investigating the notion of a machine-human interface and making it a user-friendlier place.

## **1.2 Word/Movement Interface**

Above all else, dance is the physical expression of the body's inner state of being, a manifestation of a "lived" experience that is communicated to others. Words may express the same emotions, thoughts, affects and ideas, but to do so through dance is to make a statement about the nature of movement. Essentially, dance embodies, and can therefore reveal, a different aspect of human identity that precedes verbal expression. In the pursuit of dance, the individual dancers challenge the range of their expressiveness and receptivity. One may indeed ask, to express or receive what? If our everyday movement vocabulary is sufficient to perform everyday functions and to respond to all our ordinary needs, then why develop a wider range of movement expression?

To answer this question, one could argue that our human potential extends beyond our everyday activities and that choreography is a creative attempt to explore such possibilities. My own explorations have often tried to establish a closer relationship to the source of verbal language (See DVD "Choreographing Discourse"). The search is equally for new questions as well as answers to old questions through the rigours of training, rehearsal and performance. In pursuit of these aims, my experience is that movement satisfies its own purposes, creates more movement and transforms existing choreographic styles as it progresses, often eluding our attempts to ascribe to it coherent meaning. These dances nevertheless reveal much about the processes through which phenomena come into being, i.e., become embodied, as well as the energy that brings them into being. In short, they stimulate our appetite for new knowledge by reminding us of the wonder and excitement of life, as well as the impossibility of fully understanding human existence.

To conceptualize knowledge as emanating from a source as expressed in the form of thoughts, images, movements, ideas and sounds put into a context and given a name,

one can see how language-making is perhaps the most fundamental of creative acts. Artists use any number of tools such as motion capture, movement sensing, sound sampling and image projecting technologies to represent, produce or understand this process. The tools are, therefore, never distinct from the activity performed because they form part of a larger equipment structure that allows us to interact with the rest of the phenomenal world (Heidegger, 1962). These equipment structures contain interfaces, some simple and others more complex, all of which allow us to extend our sensibilities beyond our physical bodies and consequently to receive information from a range of external sources. Choreography is an equipment structure that permits dancers to communicate and to share ideas with audiences using a range of tools and technologies. In this sense, dancers' bodies function as sites where different practices converge and diverge and information is processed and transmuted.

Movement styles like Physical Theatre and Tanztheater, for example, engage audiences in subtle discursive modes that challenge both the linguistic and movement vocabularies that function to organize these works and to make them understandable. Works in these genres generate critical dialogue about social and political issues while their often-intense emotional content challenges spectator ambivalence. In short, they expose the very foundations people rely on to construct their ideas of society and its institutions. Hence, the dance reflects an aspect of a socio-political institution that we would otherwise ignore or find difficult to integrate. Since reflection and integration are modes through which cultural evolution proceeds, these two activities exist as a continuous form of debate and argumentation.

A writer or speaker's verbal argument functions to convince listeners or readers to accept certain premises as valid, certain conclusions as strong as the reasoning is interesting.<sup>2</sup> As such, an argument places truth-values on words and their truth-functional relations. To view choreography as discourse we must, therefore, pay close attention to the values given by the choreographer to attitudes of the body in space and time, to relations between the movements of body parts to one another, and to the identities of the performing bodies of the dancers in specific contexts. In this way, complex proponent to respondent relationships can be introduced and contested within the choreographic structure of a work as well as between different performers and/or audience members.



Unlike words, movements are more ephemeral and their symbolic or semiotic references vary widely. Wordlessly they reveal a great deal about an individual's internal state. They can also engender uncertainty, instability or conflict, and when attached to a particular proposition, their changing patterns can constitute a mode of argumentation. Since arguments are sets of propositions that may or may not become conclusions, it seems logical to conclude that a dance needs no explanation other than for what it stands for. This is an important point because we can then view discussion as a means of contextualizing the dance within another body of knowledge, offering a view of the work from another disciplinary perspective, or simply contesting the point of view offered. That not everyone will be knowledgeable about the meaning or intention inherent in movement vocabularies or wish to place a dance in the context of their experience merely adds further possibilities for debate. Any confusion or lack of understanding that follows also points to a gulf between people who find it easy to conceive of their bodies as a potential source of knowledge about themselves and their world and those people who have yet to identify such connections. The concern here is that the increasing technologization of contemporary society will consolidate this form of alienation. Because of the way that dancers and other performers use their entire bodies, one must view their activities as a language that appeals to the other at a profoundly visceral level.

### **1.3 Semanalysis**

In his early research on dreams and their relation to psychopathology, Carl Jung observed a set of relationships between images and sounds in his patients' dreams and fantasies. According to Kugler (1982), the experiments that Jung and his associates carried out at the Burghölzli Klinik in Zürich resulted in two major contributions to psycholinguistic theory. The first is that a person's speech is dominated by "autonomous groups of associations" whose the core is a psychic image, and the second is that the unconscious processes of association follow phonetic considerations (Kugler, 1982: 16-18). The main idea here is that both movement and speech attempt to negotiate a continuum where memory's psychic images guide our modes of expression, helping us to understand how the kinaesthetic sense works. The combination of two signifying systems, literary text and "body language", therefore, reveals much about the complex behaviour of human beings. Hence, when Kugler (1982) comments that our psychic complexes structure not only our dreams but also

our speech, I would add that they also fundamentally influence the construction of our social and institutional organizations as well as our creative activities.

Julia Kristeva's interpretation of the semiotic as a bodily drive that manifests itself in signification is useful in approaching the relationship between verbal language and movement in terms of the continuum they both strive to negotiate. Kristeva argues that the content of words mean a great deal to the individual. She sees the rhythms, tones and movements of speech as giving rise to the grammar and structure of signifying practices. For her, meaning arises through the interaction between words and movements, and hence both must be taken into consideration if we are to properly understand human behaviour (Kristeva in Welton, 1999). Kristeva also argues that it is unfortunate that the body has always been pictured as feminine, weak, inferior and generally other because, as a result, it acquires a second- or third-order level of importance in all our social relations (Kristeva, 1984). Her contextualization of language as gendered in the female is far from unique. Luce Irigaray (1985) and Hélène Cixous (1985) draw similar conclusions, especially in their assessment of Freud's examination of unconscious drives. Kristeva's explanations are useful here because they confront the issue of conventions that establish, promote and sustain language expression as a gendered activity.

In dramatic theatre, where writing and speaking are held in much higher regard than in dance, for example, language is considered the masculine domain. Thus, when choreographers, especially women, use verbal language in their performance productions to draw particular attention to bodies, an interesting dynamic emerges. Because movement is generally regarded as a more "feminine" activity, there emerges a subtle subversion of social constructs in both the content and context of these works. The *Tanztheater* of Pina Bausch in Germany and the Physical Theatre of DV8 in England do precisely this; both these choreographers use body language as well as speech in performance to comment on social issues and provoke change. Their works demonstrate how verbal language and movement can combine into a powerful expressive force that does not marginalize the body. They are also among many who draw attention to a set of close-knit relationships, especially with respect to behaviour, that link societal and individual bodies. More importantly perhaps, they expose the assumptions that preserve people's perceptions of these institutions.



Kristeva's argument that symbolism originates with linguistic signs and that "the first act of symbolization was symbolization in and by means of language" (Kristeva, 1989: 12) puts the issue in perspective. Her theory of semanalysis uses the drama of drives, as defined in Freudian theory, to explain the dynamic transition of information from a psychic or mental sphere to a somatic sphere. These drives, she claims, possess "energy" charges and "psychical" marks, which reflect "various constraints imposed on the body [...] by family and social structures" (Kristeva in Welton, 1999: 319-320). She argues that drives have a semiotic significance and a structural consistency similar to that of verbal language.

Kristeva also claims that in Freud's theory a rupture in the transition from psyche to soma produces a loss of physical expression. In her review of Freud, she states that although linguistic activity, i.e., conversations with a psychoanalyst, can transform the contents of the psychic realm, their meanings should be sought in the translinguistic domain, namely through their decoding beyond language signification. She refers to the "vocal stresses and rhythms" often present in the "secret eroticism" of depressed people who have "buried their affects in the hidden code of their vocalizations" (Kristeva in Welton, 1999: 330-331). As a psychoanalyst, Kristeva examines a patient's intricately coded sound and movement patterns to help that patient develop a healthier mode of communication with others. Both of the choreographers mentioned above use some of these devices to stage choreographic works that are extremely articulate examinations of conventional human behaviour. For an exploration of some of these principles, see the opening two chapters of "Futurist Equation" on the DVD "Choreographic Discourse".

#### **1.4 Languages of Embodiment**

It is appropriate at this point to examine in some detail how choreographers Lloyd Newson of DV8 and Pina Bausch of Tanztheater Wuppertal challenge the conventions of language, the social order and ultimately formal dance techniques. In the work of DV8, another kind of radical activity challenges the presentation and perception of individual and social bodies. The original aim of this London-based collective dance group, formed in 1986, was to take risks "aesthetically and physically", to be "radical yet accessible", to "break down barriers between dance, theatre and personal politics", and to reinvest dance with meaning "particularly where this has been lost through

formalised techniques”. Above all, it was a forum for the communication of “ideas and feelings clearly and unpretentiously”.<sup>3</sup> The subject of DV8’s Physical Theatre work has focused on people, the construction of gender roles and the serious problems these constructions create for society. Newson and DV8’s work immediately became controversial because the group set bodies up against other bodies, the personal against the societal, and the political against the corporeal.

The group’s movement vocabulary was intensely “lived”, i.e., intimate and aggressive, and always human. It drew upon everyday environments, i.e., the street, the pub, the club, the office and the home. Newson’s distortion of the mimetic process (Kozel in Desmond, 1997) displayed a different perspective than Bausch’s, primarily because he used the gay male body in his representation of gender politics. However, he also took ordinary movement, culturally specific gestures and signs, for example, and developed them in a context simultaneously abstract, functional and challenging. His use of objects, for example, gave them particular identities that belied their objectivity. Thus, object, gesture and body were choreographically reconfigured in stage space to produce effects that were often surrealistic, but which constituted a powerful commentary on society and its conventions.

*Can We Afford This?* (2000) is a work that professes to be “about what we think we are, and what we think we ought to be.”<sup>4</sup> Newson addresses in it the problem of non-conformity. *The Happiest Day of My Life* (1999) deals with the dilemma of the individual caught between acceptance and denial of a love that is unacceptable to others. In *Enter Achilles* (1995), he examines the straight male experience as being “as oppressive as its gay counterpart”.<sup>5</sup> *Strange Fish* (1992) focuses on “the tyranny of couples and groups” and the “pain of not belonging and the terror of being alone”.<sup>6</sup> *Dead Dreams of Monochrome Men*<sup>7</sup> (1988), a DV8 classic, establishes links between the “ordinary” of brief sexual encounters and the “extraordinary” of necrophilia.<sup>8</sup> Judith Mackrell writes that Newson makes “a brilliant career out of anatomizing the politics of sex, from male alienation to female masochism”.<sup>9</sup> In this work especially, he presents in stage space the themes of loneliness, the psychology of sexual deviance, gender bias, aggression and social constraints through vocabularies of movement placed in their natural social environments.



A leading caption on the company's website prominently displays a statement by former Tory Councillor Ken Blanchard that reads, "we owe it to the community to ensure this sort of thing is not encouraged. We have to protect the public".<sup>10</sup> By quoting this statement, DV8 and Lloyd Newson announce their readiness for public debate about their obligations as artists to present issues relevant to society as a whole. This dance collective strives to present the personal body as a starting point for debate. The general debate here concerns the role that sexual difference plays in our understanding of the politics of social relations, and society's denial of any responsibility.

Newson, and others, are uncompromising with their audiences. He calls his work Physical Theatre to distinguish it from conventional forms of dance. His naming is a rejection of the ineffective type of dance that does little justice to the real issues arising from society's conventions. Tina Chanter's comment that the last decade of the 20th century saw a tremendous interest in sexual difference, deviant bodies, post-human bodies and cyborgs (Chanter in Welton, 1998) corroborates the view that new dance forms and techniques of presentation must develop if dance is to be relevant to society. Indisputably, the body has become a key text for reading individual and collective identities and for contesting institutional policies and individual rights.

In Newson's opinion, dance must find a new body language if it is to speak eloquently about contemporary social issues. He also claims that he wants to break down barriers between dance, theatre and personal politics and to reinvest dance with meaning. In going about this, he brings bodies into a new kind of focus, one that contrasts with the virtual embodiment that our technologically mediated culture strives to achieve. The ultimate goal of virtual embodiment is the perfect simulation of full, multi-sensory bodily action. This means mapping out, documenting and reproducing our entire being in virtual environments. This research argues that, although electronic simulation may be able to recreate some bodily processes, full sensory experience is possible only through our biological bodies. The Physical Theatre of DV8 takes place in the socio-biological context of lived-ness.

Bausch challenges the social order and the conventions of language through what Susan Kozel refers to as "the act of distortion in the mimetic process" (Kozel in Desmond, 1997: 101-109) and what Anna Kisselgoff calls "personal experience as

expressed in a form of distortion” (Daly, 2002: 10-11). According to Kozel, the distortion in Bausch’s work emerges from an “excess” with an inherently regenerative ability to portray bodies in space and time. She claims that this excess makes the mimicry different from the everyday behaviour that inspired it, thus creating the potential to transform social and aesthetic space. Daly, on the other hand, argues that this distortion is common to expressionistic art and especially to German expressionism, as opposed to realism, with which it is often confused. She also claims that Bausch, as a woman with a strong foundation in the tradition of *Ausdruckstanz*, does her female characters and women in general a great injustice by presenting them primarily as victims.

Likewise, in her *Tanztheater*, Pina Bausch uses language and movement to question social conventions. Bausch’s work is very much about people, but she choreographs from a woman’s perspective. Her female characters waver between acceptance and denial of a particular social convention. Daly claims that Bausch’s treatment of this conflict in *Gebirge* (1984)<sup>11</sup> is debilitating and even insulting to look at (Daly, 2002: 18). The submissiveness of the female character that Susan Endicott played in the 1985 Brooklyn Academy of Music performance of this work allows Daly to compare the views on dance in general and Bausch’s work in particular of American and German audiences.

In the performance, a man wielding red lipstick or crayon repeatedly “slashes” Endicott, who is kneeling on all fours. For Daly this “violent encounter” was “doubly despicable by the complicity of the victim” (Daly, 2002: 16). She claims that this “unheard rage of a woman”, as she calls it, reveals Bausch’s avoidance of thematic resolution in her works. In Daly’s opinion, the audience has to deal with the “stew of emotions” Bausch creates without the benefit of the choreographer’s solution. In short, the audience leaves the theatre with assumptions unchallenged. Daly sees no decisive resolution of the arguments that this work provokes, only the representation of a situation that the spectator either accepts or rejects.

Jochen Schmidt and Reinhild Hoffmann, German dance critic and *Tanztheater* choreographer respectively, defend Bausch’s position by citing the apparent reluctance of Americans to contest social issues in their contemporary dances. The discussion between Schmidt and Hoffmann, who come from very different backgrounds, focuses



attention on the interesting and complex issue of how different cultures determine how to present delicate social issues. American audiences, bombarded daily by media images, prefer not to let them dominate their contemporary dance stages. Thus, even though both German *Tanztheater* and American dance are equally concerned with “trying to find out new things about movement” (Schmidt in Daly, 2003: 8), each culture approaches the body and language differently. The fact that in their interview Schmidt and Daly find it difficult to agree on definitions of “dance”, “pure dance”, “form”, “content”, “realism”, “naturalism” and “expressionism” (Daly, 2003: 6-18) underlines the fact that these terms fall within certain contexts and/or certain discursive practices with little relation to one another. The German audience differs from the American one, and Pina Bausch’s relevance to the city of Wuppertal and to Germany often makes some of Daly’s comments irrelevant.

However, my point is that the audience has a chance to complete the work through its own viewing. Of course, the academic does not always accept this position in an argument. Some want the work to contain the premise and the argument but also the solution to the problem. Daly’s comment that the work takes no decisive position on the arguments it provokes is thus unfair. In Bausch’s work, physical movements embody the vocal text, and the body “speaks” a movement text with a kind of lived-ness that Germans understand, even if they choose to reject it. Real lives, reconditioned for the stage, provide the dance material, which reflects society and the individual’s relationship to it. The close relationships in *Tanztheater* between the work, its performers and the social context of its issues largely determine the style of the pieces. Thus, a choreographer who recognizes the injustice inherent in a system feels obliged, i.e., socially responsible, to expose it via performance commentaries.

Bausch bears out Kristeva’s argument for the body’s return to modes of contemporary discourse through a combination of the semiotic and the psychoanalytic. Kristeva’s semanalysis claims to address what she sees as a loss of “physical and psychic manifestations of drive energy” in language as a whole and discursive language in particular. Her insistence that bodily drives are discharged in representation and that the logic of signification operates from within the material body demonstrates one of the many strong arguments I raise in this thesis for corporeal recognition. Her theory that all signification operates from the distinction between the “semiotic” and the “symbolic” (Kristeva, 1998) makes a strong argument in support of Physical Theatre

and *Tanztheater* as late 20th-century performance forms that challenge notions of dance as language. Bausch does not provide solutions; she provokes people to think about their situation and make choices about how to act.

Bausch's early work *Sacre du Printemps* (1977) uses a vocabulary derived from her training as a student of Kurt Jooss, Hans Züllig and Jean Cébron at the Folkwang Studio in Essen. Thematically this work develops beyond her teachers, connecting to other prominent female German choreographers that include Mary Wigman and Gret Palucca. It also emerges from a deep commitment to the exploration of the female perspective within the tradition of German dance. In her book *Ecstasy and the Demon*, Susan Manning describes Wigman's work as feminist and nationalist, feminist because it subverts the eroticization of the female performer and nationalist because it projects an essentialized national identity (Manning, 1993). Manning's claim that Wigman projects a national identity is rather casual and dubious, to say the least, as the years 1912, 1922 and 1938 were periods of intense change in Wigman's situation and in the socio-political climate in Germany as a whole. Consequently, German national identity became a complex issue that defied simple generalisations.

However, Bausch develops some of the perspectives that other choreographers, both male and female, had attempted. Choreographed to Stravinsky's music, her *Sacre du Printemps*, for example, turns the stage into a primeval ritual site of sacrifice. This work marks the beginning of a journey in which Pina Bausch's dance vocabulary is transformed in an attempt to communicate with a public that prefers to forget its past. Daly also suggests that this work sets out a "proto-male/female dynamic" that appears throughout Bausch's work. In it, the male figure both tempts and menaces, and the female is driven by both fear and desire (Daly, 2003: 29). Daly claims that the female always overtly capitulates but is hesitant to claim that the work destabilizes the system that promotes these gender relations.

Like Newson's, Bausch's works developed in a radical direction in terms of their effects on traditions and institutions. Their aim is social commentary through a personal investigation of the means that permit or inhibit change. They also demonstrate that such ideas require new movement vocabularies. With the changes rapidly introduced by new technologies into every aspect of contemporary culture, we will certainly encounter in the future even more radical forms of dance and



performance practices. My argument asserts that the more complex our societies become, in terms of their organizational structures and their communication media, the deeper we will need to dig into the memories of our bodies. This argument underlies the development of the works on the DVD “Choreographing Discourse”. For example, the works’ movement vocabularies change from formal to improvisatory and then back to a modified formality in which the movement vocabularies, the verbal texts and the media images are more tightly interwoven. This change, of course, had much to do with the limited time I had available to work with the media. Nevertheless, it also shows that processes of deconstruction must precede reconstruction to enable the basic elements of a language of choreographic discourse to emerge.

### **1.5 Choreographing Discourse I**

As I mentioned in my general introduction, my practice as an artist is choreographing bodies in a variety of settings using different tools, techniques and technologies. As a scholar, my role is to question, to challenge and to suggest new solutions to old problems. My intention as a choreographer is to explore the body as an archaeological and an anthropological site where excavating memory is a primary objective. Thus, practice as research entails observing the process of inscribing “identities” on to bodies and recognizing these inscriptions as embodied cultural capital.

My choreographic explorations for this thesis began with a work I subsequently titled *NU* (1997).<sup>12</sup> *NU* employed a technology called Soundbeam,<sup>13</sup> and the central premise in the choreography is that vibrating sound is a central principle in any creative process. *NU* specifically explores relationships between movement and sound stimuli in a technologically responsive environment. One of the questions I was also concerned with was how far I could pursue abstract choreographic principles, i.e., the dynamics of the responsive sound space, before a narrative or emotional drama would appear. This perspective interested me for several reasons, the most important being the tension between abstraction and narrative or emotionally dramatic modes of representation in the evolution of European and American modern dance styles. This tension also relates to a choreographer’s use of technology as an integral part of the creative process and the relationships between form and content in the work itself. Those who favoured abstraction and non-narrative modes of representation seemed to have an appetite for exploring technology as content. My initial impressions were that

an intimate connection existed between the tendency toward abstraction, loss of narrative and the use of technology, but I was unsure how far one could pursue the link. Using technology as a basis for creating dances seemed to require a “disassociation” of meanings from accustomed images, which those who worked in an abstract style seemed more prepared to explore.

Merce Cunningham comes to mind<sup>14</sup> as he, along with John Cage, is often credited with ushering in the “post-modern”<sup>15</sup> in American dance. He was also the first major artist to extensively use the Life Forms<sup>16</sup> software platform on the computer to create a dance movement vocabulary. There are others who subsequently used a variety of newer technologies in more radical ways, but Cunningham broke ground here. His and Cage’s now legendary experiments in dissociating the chain of cohesion between music and dance, of removing narrative and obvious emotional content from their work and of introducing new concepts concerning creativity found a natural fit with the new computer-based technologies. *NU* was my attempt to explore some of these complex relationships with the limited technologies at my disposal. To discover how “pure dance” became “narrative dance” as well as technology’s role in the equation seemed as good a place to start as any.

As I mentioned above, the title *NU* emerged subsequently. It refers to the goddess Nu, sometimes called Nun, of ancient Egyptian mythology.<sup>17</sup> This myth explains how life emerged from the primeval ocean or waters of chaos. It is essentially a symbolic account of how an individual comes into existence (Budge, 1954). *NU* developed into a process of using sound to organize choreographic, mythic and technological space, drawing on abstract ideas embedded in this myth. With the help of this myth from a specific cultural context, the research I did for this work drew together different notions of creativity. Both creation myths claim sound as the zero point from which a chain of consequences lead to the embodiment of entities. The dancers’ triggering by body movements of electronically programmed sounds in a “call and response” dynamic attempts to explore technology as an expressive partner linking different notions of the creative process. The new hybrid that emerges from the two creation myths also identifies the computer-human interface as a place where culturally specific notions of creativity and embodiment can co-exist. Although I chose to use a culturally loaded word as a title for the dancework, my intention was to remain as abstract as



possible, in the sense of not following the Egyptian myth in any obvious narrative detail.

The rehearsals for *NU* proceeded almost entirely without the sound equipment, but we worked on the assumption that we were initiating and responding to sound data. The point was to be aware that sound could be sensed as vibrations between people and objects in any environment. We had only to pay attention to natural sounds, i.e., breath, body movement and any sources of sound. Because the technology was unavailable, we introduced the ultrasonic sensing system extremely late in the process.<sup>18</sup> Even though Soundbeam is not a sophisticated piece of technology, the results obtained from our explorations were often quite complex. As I mentioned above, the lack of a prolonged opportunity to work with the technology limited the research; nevertheless, we made some valuable discoveries about the performance possibilities of live dance in an electronically mediated soundspace.

One initial experience was that the performers became acutely aware of the space itself as a sensual organ. Even though our movements would later “trigger” a series of mostly programmed responses from the technology, these experiences enabled us to conceive of a different relationship to our environment. The act of listening and responding to an “absence” eventually replaced that absence with an inspiring “invisible” presence. We worked as if we were blind and could navigate only via sonar. Our intention was also to create analogies and explore interfaces between choreographic, mythic and technological spaces. I believe that this intention becomes inevitable for anyone working seriously with a technology like invisible ultrasonic beams, or for that matter any technology that allows one to explore different ideas of reality. Something in the process connects to a primitive urge to associate with archetypal images. As these realms come into contact with one another, a new “lived” experience becomes possible.

When the dancers had their first experience with the sensing devices (this involved a weekend trip to Bristol from our rehearsal spaces in London), they reacted to the electronic sounds their movement “created” with surprise and amazement. In my own workshops with able-bodied, physically and mentally challenged, and highly trained bodies, I came to realize that this was a normal response. Human beings are accustomed to interacting with others in a number of ways but as soon as something

inanimate responds to our actions, disorientation occurs. To capitalize on and extend these moments, we adopted several strategies. One of these was improvising and taping conversations, sampling them electronically and programming the results discretely along the invisible sound beams. With three of these beams strategically placed and operated by a programmer at the side of the stage, we were able to create a complex architectural network of spatial directions, sound content, movement paths and “sensitive spots”, all of which supported an abstract movement “narrative”. The result, as mentioned above, was that the space, the disembodied voices of the dancers and the bodies of the performers created an environment that was more “alive”.

Another result of the research was that the technology made us more aware of our skin as a surface, as an envelope that both contains and limits. Also significant was the feeling of distinct connections between animate and inanimate things. Together, these findings led to notions of physical and mythological space on either side of a metaphorical skin.

*NU* premiered at the Place Theatre in London on 16 January 1997 as part of the “Resolutions ’97” series. It opened up possibilities that might have been overlooked had I not done some research on ancient Egyptian culture years before. At that time, I choreographed a quartet entitled *Ich Khepera* (1988), which explored the symbolic nature of the family triad of Osiris, Isis and Horus with another older composite funerary god Ptah-Kheper-Osiris (Budge, 1954). This latter god represents matter on the point of rising from inertness into life as well as a mummified body about to emerge into new life.<sup>19</sup> Research on *NU* re-stimulated my interest in how modernization and increasing specialization tend to create seemingly disparate bodies of knowledge. In particular, I was interested in reviewing notions of disembodiment, as it was in disembodiment that the ancient Egyptians prepared for their reappearance or rebirth in another space-time location. The link between cybernetics and Egyptology is a tenuous one, but there is something highly credible about the notion of bodies of knowledge reconnecting through our corporeal existence: sacred and mythological space are thus linked to technological and psychological space through the performative.

The ideas embedded in *NU* are complex, even as the work tries to find a simple choreographic method of approaching them. An important underlying idea is that



human beings share a space with intelligent entities they acknowledge, or pay respect to, in vastly different ways. Through a fusing of images in the world and those in our imagination, we create templates for embodiment. As soon as a sound is heard, a simultaneous movement differentiates creative space. *NU* was a step in assessing the wider possibilities that exist, not merely choreographically, but in terms of an excavation of memory.

This first collaboration with Elektrodome of Bristol would provide a rough template for two successive works. *Octo 15 '97* (1997) and *Virtual Illusions* (1999) were primarily created and performed in Bristol, the former at the old Leadworks and the latter at the Industrial Museum, both in the city's downtown waterfront. *Shango Meets Ogun* (1998) also uses Soundbeam technology, but that work was produced in another context with the help of research funds from King Alfred's College of Winchester, the University of Antwerp and Full Performing Bodies, a performance company I founded in Winchester. Of these three works, only *Shango Meets Ogun* had successive performances, touring venues throughout England in 1999–2000 as part of Peter Badejo's Tilewa dance platform.<sup>20</sup> Quite importantly, I used a crude form of motion capture technology to acquire footage that was thematically repurposed in *Shango Meets Ogun* and *Out-of-Body* (2002). [See DVD "Choreographing Discourse"].

As I mentioned previously, Soundbeam allows the dancer to experience a sensation of being physically connected to the surrounding space and the objects in that space. The mechanics of the interaction are very simple: a device sends out a series of high-frequency ultrasonic pulses or beeps that the performer breaks by moving any part of the body. It is inconsequential what part of the body triggers the device as the distance to that body part from the sensor is automatically measured and the information routed to a control centre for processing. The information is then used to modify other information using the MIDI protocol.<sup>21</sup> This one-to-one analogy between the movement and the sound is relatively simple, but the process can become more complex and interesting when the sound designer and the dancers are free to interact within the installation, making decisions that are pre-negotiated or improvised. My experience has been that viewers clearly share the sense of spontaneity and excitement that this kind of interactive performance delivers, identifying with something beyond the technology, even though they are not aware of exactly how it functions. In *Shango Meets Ogun*, a work that explores relationships between human beings and Orishas,<sup>22</sup>



this ambiguity works quite well. In *Octo 15 '97*,<sup>23</sup> the industrial nature of an old lead works factory, a great deal of exposed technology and an unsophisticated movement vocabulary creates an interesting site-specific narrative. In *Virtual Illusions*,<sup>24</sup> performed with 3D VR (Virtual Reality) headgear, a different experience of being in an immersive space develops, one that challenges the “normal” spectator/performer relationship.

The success these works achieve results from a number of elements. In *Shango Meets Ogun*, a complex call-and-response dynamic between the technology and the mythic characters allows a specific cultural identification that spans local time and space, and in *Virtual Illusions*, a more complex technological setup produces the feeling that working with sensing technologies requires the performer to interact with tools and space as if both are sentient and/or intelligent beings. All of these works promote the distinct sensation that the performance space contains residual memories of previous events, which in turn made me explore the possibility of recognizing and/or reconstructing a former “lived” event from memory.

In concluding this chapter, I would like to introduce the idea that the complete details of an organism’s or entity’s history can be retrieved from its memory. Further, if the organism or entity is capable of self-reflection or is conscious of its actions, it can recognize events from its own history as well as those of its class or group. The information gathered from this process of re-cognizing appears in extremely complex formations. Attempting to decipher them as individual experiences is extremely difficult. However, through this process many artists create the “stuff” of dance, perhaps the most elementary language of human behaviour.

## Chapter II Recognizing Corporeality

### 2.1 “Re-cognition”

The continuity of any cultural phenomenon, the praxis of any body of knowledge, involves a string of people not simply learning a set of axioms which someone invented in the past, but also themselves repeating the cognitive breakthrough of its “inventor” and actually re-inventing the institution itself each time. Any phenomenon — geometry or performance, for example — can be understood and practised only when each new member repeats the original cognitive leap (George, 1996:16-17).

In this chapter, I will argue for contemporary dance practices as an archaeology and an anthropology of the “lived” body, and for choreography and performance practices as means for exploring bodies as sites of knowledge. I mentioned in the last chapter that the choreography *NU* creates an interface between choreographic, mythic and technological space that allows audiences to have a unique experience. My intention was to contextualize contemporary dance and related performance practices within a cultural framework. In this new framing, bodies are sites where lost, forgotten or fragmented memories are remembered and reconfigured. Hence, the processes that detail the development and demise of cultures, which include their use of technologies, their stories and myths, as well as their rituals provide valuable data for study and choreographic exploration.

The underlying premise is that our every act gets recorded in memory, and each act relates to earlier and later acts to make up our entire social and bio-evolutionary history. We have the potential to re-cognize the sequence and nature of these events through various body practices. The body thus becomes a living, moving memory of history, the site of complex metanarratives that we look to for solutions regarding the nature of our human existence. This remembering is facilitated through performance, a process that allows us to re-establish connections that have been either severed or rendered inoperable. My research claims that we construct our individual identities out of this mass of information. These identities are never complete because we are



continually in a state of remembering, trying to understand what we do and why we do it by processing what is essentially already in our bodies and environment.

This study also suggests that we are a plurality, a collection of identities or configurations of memory. An important role of performance is to “re-cognize” or “re-member” these other identities. To be aware of these “selves” and to find ways of embodying them is crucial to the process. My attempts to articulate a first-person methodological approach for practice-led research that re-evaluates the notion of a machine-human interface finds support in the phenomenology that Edmund Husserl (1859–1938) strove to define (Husserl, 1931, 1960, 1964, 1969, 1980, 1999, 2002). One of the central tenets of phenomenology is that science is built entirely upon a world that is directly experienced (Merleau-Ponty, 1962).<sup>1</sup> I argue that technology, in its role of mediating our daily activities, generates a range of second-order experiences. We, therefore, become “twice removed” (Schechner, 2002)<sup>2</sup> from “original” sources of experience.

Since technology is the reformulation or reassembling of techniques that have been deconstructed and fashioned into an efficient tool, we can argue that the techniques and movement vocabularies of performers and choreographers are artificially constructed and thus can only generate second-order experiences. If, according to this hypothesis, all that human beings can do is to remember or recognize what already exists, then we can also argue that there is, strictly speaking, no such thing as a first-order experience. However, phenomenology proposes that an experience is fully “lived” if we experience it as a thing in itself, without “pre-reflection”. Then it is possible to experience a true sense of discovery, which motivates the artist to create and/or embody.

However, people can have experiences of which they are not aware. This might seem ridiculous to common sense, but the idea is at the core of cognitive science and psychoanalysis. Varela and Shear (1999: 1-14), for example, claim that there is great flexibility in this non-conscious or subpersonal space for “pre-reflexive” phenomena to manifest themselves. Their argument revolves around the belief that the pre-reflexive represents a rich and largely unexplored source of information, which can be brought to the fore with the assistance of new methods. These include the following:



- 1) Providing a clear *procedure* for accessing some phenomenal domain.
- 2) Providing a clear means for an *expression and validation* within a community of observers who have familiarity with procedures as in (1). (Varela & Shear, 1999: 6)

Any choreographic tradition or individual choreographic style, no matter how idiosyncratic, illustrate these two pre-requisites. As a first-person methodology, practice-led research already has an established basis for assessing the work. However, the extent to which third-person methodologies, as “procedural and social regulations” identified as the scientific method permitting “the constitution of a corpus of shared knowledge about natural objects” (Varela & Shear, 1999: 1), apply to practice-led research in dance and performance is a thorny issue with which this thesis grapples. When Husserl claimed that to subject science to rigorous scrutiny, we need only return to the basic experience of the world of which science itself is a second-order expression (Merleau-Ponty, 1962), he outlined a method for performers to evaluate science, and scientific principles, from the primary experience of their craft.

Mario Biagoli, in his essay “Tacit Knowledge, Courtliness, and the Scientist’s Body” claims that “the scientist’s manipulation of an instrument to have it yield meaningful results may not be unlike the bodily skills expected of a courtier to achieve the appropriate presentation of self”. He argues that both perceptions result from specific forms of “disciplined subjectivity” (Biagoli in Foster, 1995a: 69-81). The underlying principle is that practices have to be accepted, or as Biagoli terms it, “blackboxed” before they can be reproduced or replicated, since replication signals scientific rigor and verifies hypotheses. Since in dance each performance offers a different experience, one can argue that replication in this case does not imply identical results during each performance. Rather, one attempts to replicate a specific procedure, which can reveal new information about the identity of the performer or audience member.

Biagoli’s main argument is that science follows a set of traditional conventions, which must be accepted before a single experiment is conducted or a single hypothesis investigated. In other words, individual researchers must first gain access to the institution of science before that institution will consider or accept their practices. Since for the most part academia does not acknowledge or accept the conventions of body that underlie dance and performance traditions, dance has difficulty asserting itself in academia’s institutional framework and/or the knowledge economy. Foster

argues that “the metaphors, enunciated in speech or in movement, that allude to it [the body] are what give the body the most tangible substance it has” (Foster, 1995a: 4). For her, bodies make history, and these bodies “configure a tradition of codes and conventions”, that allow them “to represent and communicate with other bodies” (Foster, 1995a: 10-11). The principle of re-cognition that is being explored here requires attention to the conventions, traditions and practices of the discipline of dance and the range of its performance activities. In this way dance and the body finds themselves at the centre of a trans-disciplinary discourse on the nature of performance. Since phenomenologists insist that the world exists even before we analyse it, and that analyses do not necessarily convey ideas essential to the world’s existence, the issue of attention becomes a primary focus. This latter issue determines what we can perceive about the world and what meaning different phenomena have for each individual. In the introduction to his *Phenomenology of Perception*, Merleau-Ponty re-iterates Husserl’s claim that the body reveals itself to the world and to itself through the intersection of an external tactile sensation and an internal kinaesthetic one. The “lived body”, he argues, exists in the spaces between the two, and just as we experience it, we reveal it to others (Merleau-Ponty, 1962). In other words, the felt and the perceived co-exist in the “lived-body” as a system of experienced movements (Welton, 1998: 47-48). This is the experience I referred to in the last chapter with regard to *NU* when I stated that the performers had a sense of their bodies mediating between worlds and then becoming those worlds.

In the table below, Welton (1998) describes what he believes are important steps to a Husserlian analysis of the materiality of the lived-body, steps that I will refer to throughout my discussion of relationships between types of bodies, institutional, individual and otherwise. These steps also serve to connect a variety of approaches that I will use in ensuing discussions of the “lived” body at the junction of science, art and technology.

1. In our direct and immediate awareness of the body, we know it primarily through the various *tactile sensations* involved in any activity of touching something. In fact, Husserl’s argument is that a subject that had only vision would never know the body as lived-body.

2. One of the unique traits of tactile sensations is that they are given as having a *location* in the lived-body. Their location is not a series of discrete points but a *field*.



3. The field of sensations is experienced as functionally dependent upon a *real order* of circumstances and events. Each significant change in things and the actions of things upon the surface of the physical body produces a change in the field of sensations according to a scheme of *conditional dependency* (author's italics), an "if-then" scheme.

4. Since changes on the surface of the body are experienced as changes in the field of sensations having that location, the lived body is manifested as material. (Welton, 1998: 47–48)

## 2.2 Lived-ness and Metakinetic Transfer

The idea of the "lived" experience outlined above helps to articulate the theoretical framework of this research. It also has some roots in early dance research, prior to attempts by specific dance writers to locate it within phenomenology (Sheets-Johnstone, 1966 & Fraleigh, 1986). In fact, one could say that some of the ideas expressed in Husserl's (1960, 1969) and Merleau-Ponty's seminal writings (1962, 1969) respond very much to a need in the dance research community to formulate new methodological approaches that embrace the dancer's instinctive kinaesthetic intelligence. In this respect, I feel that it is important to mention a connection to the early modern dance movement. This connection becomes even more relevant later on as the obvious displays of emotional suffering and dramatic narratives that fuel this early notion of the "lived" give way to abstraction, deconstruction and eventually a preoccupation with technology's procedures and tools. In other words, I am suggesting that there exists a direct link between the use of technology and the tendency to abstraction and emotional distancing in dance at the same time that there is a deepening of expressive content in an entirely new and perhaps opposite direction.

To define a theoretical perspective that can embrace this idea, I would like to begin with the work of dance writer John Martin and to continue with recent studies in cognitive science, AI (Artificial Intelligence) and AL (Artificial Life). Martin's notion of "metakinesis" or "kinetic transfer" (Martin, 1965, 1968, 1978, 1989)<sup>3</sup> provides a useful link to my own perspective on re-cognition. A long-time critic for the *New York Times*, Martin (1893–1985) wrote a great deal on American modern dance pioneers and the European dance groups that toured North America before the Second World War. He was extremely impressed by the work of Martha Graham, Doris Humphrey, Jose Limon and Mary Wigman, for example. Martin described Graham as the "flood

and fire” to Humphrey’s “stream and light” (Martin, 1968: 185). He thought that Graham had a strength that was “almost masculine” yet projected a “wholly feminine mind, intuitive, impressionable, passionate, tempestuous”. Humphrey, he wrote, was “feminine to the fingertips”, even though she thought with “a logic and an analytical curiosity” that was “largely masculine”. Limon he described as “magnificent [...] with a natural gift for movement” (Martin, 1968: 282). Martin had a special place for Wigman, whom he claimed was second in importance only to Isadora Duncan in the history of modern dance (Martin, 1989: 115-118).

Martin’s vocabulary reflects his identification with the physicality, natural organic vibrancy, and emotional and intellectual qualities of these artists. He also quite noticeably cross-genders the personalities with his descriptions. Martin’s “metakinetic transfer” explains those dancers’ qualities “for which words are not adequate” (Martin, 1965: 13), and he argues that dance communicates from one person to another an aspect of our being without actual physical contact. His understanding of dance as a medium for transferring aesthetic and emotional concepts from one individual to another is interesting for the period in which it was written. He describes it thus:

There is correlated with kinesis a supposed psychic accompaniment called metakinesis, this correlation growing from the theory that the physical and the psychical are merely two aspects of a single underlying reality. (Martin, 1965: 13)

It is interesting to note in the above-mentioned writings Martin’s silence or scepticism of Merce Cunningham’s work. The latter’s choreographic principles and thematic choices were diametrically opposed to those Martin admired. Merce Cunningham and his main collaborator John Cage were harbingers of American “post-modern” dance, and the two men were clearly aligned with the spirit of Modernism that greatly influenced American art from a powerful European base. These two men considered dramatic narratives and an outpouring of emotions irrelevant to their artistic aims. As far as they were concerned, the body was not the site for heroic narratives and tragic depictions. Cunningham’s interest was strictly focussed on the interactions of bodies and their movement in time and space, and his work consistently avoided associative emotional baggage. John Cage’s music was an additional deterrent to emotional expressiveness; he preferred chance operations and the reconstituting of natural and artificial sounds. Cunningham and all his collaborators made concerted attempts to



dissociate themselves from the traditional modes of creating theatrical dance and this, it seems, provoked Martin's intense scepticism.

Although he must have been aware of the motives and sensed the implications of these activities, Martin was not comfortable with them. In fact, his metakinetic principle seemed to derive its power from a source that this new direction in dance ignored. The generative power that connects the individual's psychic and emotional life to a kinetic manifestation in the body was not obvious in Cunningham's dances. To Martin, and others, there seemed to be no emotional depth, no striving and searching for identity, at a time when the performer had to be "true" to the role.<sup>4</sup> The works of Cunningham and Cage, ruled by a different aesthetic, followed completely different aims. In my opinion, Martin's reluctance to accept the modern dance of Cunningham and Cage arose from his reliance on the emotive-narrative appeal as the driving force behind metakinesis. Of course, his theories were ineffective when applied to the Cunningham/Cage collaborations.

Martin wrote at a time when dance was undergoing great upheavals. He felt that this "most elementary physical experience of human life" (Martin, 1965: 7-8) was a powerful acknowledgement of the importance of the psychological drives that motivate human beings to express themselves. He believed that this kind of expression was a condition for being alive. He was correct, of course, but the narrowness of his definitions excluded other forms of "lived-ness". Martin's thinking could not readily accommodate the shift to new ideas that could express other life forms. His vision could not accommodate the additional layers of discourse suggested by the works of post-modern dance choreographers. Copeland and Cohen argue that he did not pay sufficient attention to the "conventions presupposed in the conveying of meanings" (Copeland & Cohen, 1983: 3), and such conventions, as we now know, influence an audience's willingness to receive a work. In conclusion, the association by "kinaesthetic sympathy" alone is not enough to convey a fully lived experience, and Martin was unwilling to analyse on their own terms other elements, i.e., a dissociation in the chain of cohesion between, music, dance and emotional narrative, that were present in the work of Cunningham and Cage. However outdated his ideas may be, his work is relevant to this research as it reveals links between abstraction in art, the consequent removal of emotional elements that some identify as signs of "life", and the dehumanising tendency that others claim technology promotes in social relations.

In the early literature on dance and phenomenology, one can identify yet another aspect of this relationship between distancing and associating. For example, Sondra Fraleigh's 1987 text *Dance and the Lived Body* questions the term "instrument" that dance-makers use to describe their relationship to their bodies. She argues that this language produces important subtexts in the work performed. Fraleigh claims that the term "instrument", when used in the context of the body, tends to indicate a separation between the mover's mind and body, and hence the mover abdicates agency. Drew Leder, in *The Absent Body* (1990), also emphasises this idea of abdication, losing one's relationship to the body. Leder does not write as a dancer or performing artist, but his critique is even more devastating. He claims that, as far back as the ancient Greeks, our cerebrally centred Western intellectual history tends toward an institutionally dictated disembodiment.

It is not difficult to see why such a criticism has been levelled at Western intellectual history. In the time of Descartes during which this tradition was consolidated, a strong social, political and religious conditioning of the body shaped much of intellectual history. As another example, the Thirty Years War that raged across Europe from 1619 to 1648 was a complex event that characterized the spirit of the age, among which were themes of religious freedom, national identity, political hegemony, social transformation, intellectual freedom and resistance to imperialism (Asch, 1997). The challenge mounted against the power of the Church resulted from internal conflict among Catholics, Lutherans and Calvinists. My point is that the age which produced Descartes and his philosophy of a mind/body dichotomy resulted from a physical and conceptual rift in the body of society. Part of society was in deep denial, and this got expressed in terms of the intellect's ascendance over a base and stubborn body. Thus, the institutionally dictated tendency toward disembodiment, which Leder refers to above and which continued through much of modern history, denies body practices the power that it deserves. In my attempt to establish a framework in which theory plays a role, I approach the issue with the understanding that practice, i.e., my choreographic practice, is a discursive activity in which the process speaks for itself. At the centre of that process is the body and its experiences of life. The "lived" body is thus the memory of embodiment, as memory comes into body and experiences corporeality as life.



### **2.3 The “Lived” Machine**

Machines do not have the experiences that human beings have, but they can be made to simulate some of these. Human beings can incorporate micro machines or mechanical parts into their bodies. As people and machines grow closer to one another new formal possibilities are created. The idea of a machine-human interface, as discussed in this thesis, is a physical site as well as an idea or concept. In terms of existing in space and time, both the physical site and the concept are realized in the notions of cyberspace and cyborgs. For human beings, automatic or machine-like behaviour contrasts with conscious and/or intentional behaviour. Thus, the range of what can be considered a machine-human interface is quite broad. However, to distinguish between the formal possibilities in these two extremes, we frequently use terms like intelligence, agency, consciousness, self-consciousness and will. All of these words suggest the power of awareness as linked to the power to act. Awareness is, therefore, paramount in terms of our ability to act meaningfully. It is also a key element in the creative process as it functions as a kind of nourishment for the artist.

Impressions, perceptions and memory are three key elements in developing an acute awareness. Impressions feed our perceptive abilities, and both contribute to the memories that people instinctively access in their daily lives. Spectators assimilate information through images, then consciously and unconsciously process them in relation to their own experiences. Our memory is, therefore, constantly being organized and re-organized as we negotiate new sensory data. The hippocampus at the centre of the brain acts as a switching station for neurons stimulated in the cerebral cortex, where long-term memory is “stored” (Harris, 1998), and guides these negotiations. The hippocampus “decides” which incoming impulses join already stored and experienced or “lived” memories. These incoming impulses travel to our short-term memory, which is akin to a computer’s RAM, as well as to long-term memory, which resides in our cerebral cortex and resembles a computer’s hard drive (Pinker, 1997). Since impressions or sensory impulses function as the food that nourishes our awareness, when they reach a certain threshold of activity between bodies, entire blocks of memory can be triggered (Jáuregui, 1995), which literally engages the knowledge that David George (1996) refers to in the quotation at the beginning of this chapter. In this manner, the institution of performance is “re-invented” each time an individual makes an original cognitive leap. In the absence of

an “original” cognitive leap there is no learning. To make that leap we must assume the availability of a database of stored impressions. Whether these impressions originate with the individual or with some other medium is irrelevant: what is important is whether the impressions can be assimilated.

Ray Kurzweil, one of the world’s foremost authorities on AI, believes that human beings will eventually inhabit silicon-based bodies (Kurzweil, 1999). This belief implies that the “stuff” of awareness is transferable. Kurzweil represents part of a growing trend of radical opinion concerning the current and future role of biological bodies and our need to consider how to replace them when they wear out. The human race’s potential to evolve through its own efforts rather than nature’s alone is the fundamental issue here. If the scientific speculations of Kurzweil and others are to be taken seriously, it appears that a large part of our knowledge production and cultural industries are geared towards achieving humanity’s dream of immortality through virtual embodiment. Such speculations provide compelling reasons for us to revisit the notion of the “lived” experience and to attempt to formulate new theoretical perspectives that can incorporate body practices as a way of knowing and of transformation.

Creating a perfect blend of machine and human being in the cyborg means modelling living creatures, especially human beings. AI researchers spend a great deal of time modelling living biological systems through complex algorithms. However, the entities these researchers create “live” in form but not necessarily in matter (Langton, 1989: 1-47). For other researchers like Zohar and Marshall (1993) a marriage between physics and psychology is a route to locating the origins of consciousness and perhaps simulating it. This physics of consciousness establishes a vital link between thought processes and quantum processes that allow form to play a crucial role in emerging life. This claim that thought processes and quantum processes play a crucial role centres on the idea that since medical psychiatry treats problems affecting consciousness by regulating the primitive forebrain, consciousness does not coincide with the higher brain functions permitted by neurone connections in the cerebral cortex. Zohar (1991) argues that the *form* (her emphasis) that consciousness takes is influenced by these connections, but the capacity for consciousness itself is far more primitive than the developed human brain. It is a mechanism equally available to the human being and the amoeba. In her opinion, the parity between the physical basis of



consciousness and the reason for human consciousness may well be the evidence needed to further our understanding of the distinction between life and non-life.

If, as Zohar suggests, the secret of life lies not in the higher brain where the intellect is situated but in the lower forebrain where more primitive instinctual behaviour lies, body practices become all the more important as a mode of discovery, learning and transformation. Zohar's explanation of a biological/psychological interface is useful because it indicates a method for observing how the mechanisms of life operate at the boundaries of consciousness and how "lower" body functions determine many of life's complexities. Since one idea of performance is that our bodies' physiological systems repeat rehearsed patterns inherited from millions of years of genetic development, a key aspect of consciousness could be how individuals learn to observe the processes of their behaviour. In other words, since all the data exists, consciousness can be developed intentionally through certain body practices.

## 2.4 Crick's Search

In his book, subtitled *The Scientific Search for the Soul*, Francis Crick, 1962 Nobel Prize winner (with James Watson and Maurice Wilkins for work on the double-helical structure of DNA), argues that everything we do, all behaviour, can be reduced to the physical operations of the mind-brain. He writes:

The scientific belief is that our minds — the behaviour of our brains — can be explained by the interaction of nerve cells (and other cells) and the molecules associated with them. (Crick, 1994: 7)

He concludes his main argument with the following statement:

The language of the brain is based on neurons. To understand the brain you must understand neurons and especially how vast numbers of them act together in parallel. (Crick, 1994: 256)

Crick mentions free will only in a postscript, where he claims that free will is merely an ability to make decisions (his examples include verbal responses and physical movement actions), which are controlled by a region "in or near" the brain's "anterior cingulate sulcus", a region "at or near the higher levels of the motor system" that receives "many inputs from the higher sensory regions" (Crick, 1994: 267). He also implies that the much-celebrated notion of free will is merely a process of decision-making.

Crick's argument presents a mechanistic view of human beings. It is a top-down cognitive view of the human being that suggests other systems that simulate mind-brain functions control the body. The concept of "re-cognition" proposed in this research is a bottom-up embodied view, in which human agency is not an exclusive brain-centred activity. In his book *Passionate Engines* Craig DeLancey (2002) argues for an appreciation of the role that emotions play in our mental lives, claiming that a bottom-up view facilitates an autonomous integration of motor control with perception and affect. He is especially critical of the cognitive approach to mind of philosophers like Dennett. Unlike Dennett, DeLancey rejects cognitivism in his analyses of mind, using instead a version of affect program theory, which explores affects as body states that are motivational, meaning that they produce or induce behaviours in the body (DeLancey, 2002: 5). Essentially, DeLancey tries to clarify the role that emotions play in processes of embodiment from the position of a philosophy of mind.

Since research has confirmed that emotional stimuli as well as information entering the brain influence the role the hippocampus plays in negotiating memory (Harris, 1998), we can say that the body itself is a large mind. Intention is visible at all levels in this body, not solely in the mind-brain. Dennett (1996a) proposes a form of intentionality designed to operate in human as well as non-human systems. He speaks about "intentional systems" and of "entities" as organizations performing like "*information-modulated*" and "*goal-seeking systems*" (author's italics). He also refers to "intentional stance", which he claims is a "strategy of interpreting the behavior of an entity (person, animal, artifact, whatever) by treating it *as if* it were a rational agent" that governs its "choice" of "action" by a "consideration" of its "beliefs" and "desires" (Dennett, 1996a: 26-27). Particularly striking here is the language that Dennett uses to describe these non-human systems, i.e., agents utilising choices, beliefs, desires and so on. His argument is that whenever one adopts an intentional stance toward things other than persons, a process of anthropomorphism takes over to transfer life-like qualities to inanimate objects. Crucially for him, the intentional stance is the key to understanding the nature of minds.

Dennett's intentionality thus accommodates the notion of a living machine-human interface while DeLancey's perspective is concerned more with a biology and a rationality of the emotions. Both these writers address intentionality at the human-machine interface as a product of the particular behaviour of extremely complex



systems. However, they also offer suggestions on how not to deal with human bodies as merely computing machines. By stressing the relationship between inherited capabilities in bodies, DeLancey draws attention to an interface between biology and culture where emotions become intentional sources of actions or “*action-directing intentional states*” that have a logical status (DeLancey, 2002: 95). He also argues that any theory of intentionality must allow for both linguistic and non-linguistic modes of enquiry and/or representation: they should be “sub-cognitive”, as he believes the term cognition is invariably defined within the context of mind, which predicates language as its mode of communication.

I propose here the idea of corporeal re-cognition, or remembering the totality of the body, as a route to consciousness of self. It is also a key aspect of my theoretical approach to choreography as a practice-led research strategy. Crick, in his claim that “the aim of science is to explain *all* aspects of the behaviour of our brains, including those of musicians, mystics and mathematicians” (Crick, 1994: 259), may not have considered the implications of his pronouncements in other fields of investigation, but he is neither the first nor the last scientist to neglect body practices as valid modes of scientific enquiry.

## **2.5 Choreographing Discourse II**

One of the primary considerations in this research has been the exploration of different approaches to language as a means of recognizing processes of embodiment. As a choreographer, I am interested in how audiences recognize particular texts in performances and how these texts become meaningful for them. I mentioned earlier that, since attention is central to the spectator/performer relationship, choreographers are always seeking new strategies for engaging the viewer. As I also previously discussed, stimulating emotional responses is an effective method for establishing immediate and strong links from the hippocampus to the cerebral cortex and thus to stored long-term memory. The deconstructive strategy of fragmenting, dislocating things from their accustomed contexts, and destabilizing and/or disrupting conventions and linear timelines are ways of reordering memories along these paths. The two strategies operate quite differently: the former generally tends to encourage narrative readings while the latter discourages them. Viewers, in the latter instance, experience a kind of alienation or dissociation of selves as they attempt to put things into context.

This alienation is especially strong in verbal language as we attempt to communicate precisely what we mean with words.

In my staging of *Relatively-Well-Centred*, I used a variety of verbal texts with specific meanings. In some way all of these texts problematize notions of centring and decentring, balance and imbalance. However, I also used these texts as a strategic device in the work's tonal structure, i.e., the musical accompaniment. The dancers spoke these texts, which were recorded separately and later recombined in the musical composition. The dancers also spoke the texts as they rehearsed the dance movements so that when the recording process came, they spoke with the memory of dancing the words. In the work's performance, the dancers had only one of the texts, so that they then danced with the memory of the text in their bodies. The purpose of this strategy was to get the performers to embody the text, to give them a means of framing their words according to the rhythms of speech and vice versa, to distract them from the movement when they spoke and from the text when they danced, and finally to provide the full impact of these memories in the performance.

The general purpose behind all this was to hide the coherent narratives of the original texts from those who did not know the context and to reveal them to those who did in a completely different way. Thus although this was an abstract work, the series of other narratives expressed through the movement of the bodies, the sound score and the video images allowed the audience members to decide for themselves the work's meaning. In the event that they preferred not to make a choice, the images would nevertheless enter their sphere of comprehension through other means. This choreographic discourse that uses musical ideas in recontextualized sound recordings, and that borrows literary texts and organized movements presents a complex scenario that loses some of its power through the explanation of its strategies but also gains power for precisely the same reasons. The point here is simply that there are at least two ways of perceiving and of gaining awareness and that each way stimulates a different set of meanings for individual audience members.

This fact is reminiscent of Derrida's (1986a) claim that we create meaning and identity through our interaction with the structures of verbal language. What he means is that the individual is not the centre of meaning, the structure is. The latter with its pairs of oppositions creates meanings. This suggests that we define our selves only as far as the



prevailing system of verbal language allows. However, since this research looks at language as a creative interaction between a complex system of texts that is not solely linguistic but includes dance and/or body movements as prominent reference points, these latter must establish their own referentiality as a system of differences if they are to be effective in communicating. Returning to a statement I made earlier in this chapter, I see a definite link between abstraction, deconstruction, fragmentation and distancing that links “post-modern” choreographers to one another and to the use of certain kinds of technology. However, these links have become more complex, and a different kind of narrative, use of emotion, and use of abstraction appears in contemporary works. There is, in effect, a new kind of relationship to the notion of life and the “lived”.

When Bertolt Brecht (1898–1956) used the concept *Verfremdung*, German for alienating or making strange, in his attempt to remind audiences of theatre as a different form of reality, he was essentially using a strategy of disassociation so that people could form new paths to cognition or at least erase old ones. The concept of *Verfremdung* resembles other methods used by the Futurist, Cubist and Dadaist movements. These strategies all had an inherently political dimension as they encouraged the individual to resist the systematic mechanization, institutionalization and automatization of self. One can say that, throughout the 20th century, abstraction, distancing, alienation and fragmentation systematically opened up alternate spaces that the digital technologies of the information age would rush in to fill.

Before the digital age, other performing arts disciplines used many of these techniques. In music, for example, Arnold Schoenberg (1874–1951) developed the twelve-tone technique as a system of musical composition that completely reoriented and often distressed the listening habits of early 20th-century listeners. In this same era both abstract painting and psychoanalysis also developed. These developments indicated not only a deepening of awareness of the human condition but also of strategies designed to explore this new area. A set of my own works parallel some of these developments in their use of thematic and compositional ideas. One work, *Walk-About-Timeless* (1995), marked a sort of watershed. *NU*, in some ways, followed from *Walk-About-Timeless*,<sup>5</sup> a work that used the second of Olivier Messiaen’s (1909–1992) seven musical Modes (Fig. 1 below)<sup>6</sup> as a formal structuring principle. This work used

**BEST COPY**

**AVAILABLE**

Variable print quality







**Fig. 2 - Messiaen's Second Mode with transpositions<sup>8</sup>**

logic and his theory on sound vibrations with the Australian aboriginal concept of creation as a journey in time by “ancestral gods” that resulted in the creation of their physical world (Turner, 1980; Corbally Stourton, 1996). Thus, one of the principal differences between the two pieces lies in the approach to making the music or sound, while one of the main similarities is the use of sound as a source of vibrations that can resonate across different dimensionalities, locating sympathetic affects in bodies.

I used Messiaen's second Mode (Fig. 1) to help structure *Walk-About-Timeless*. The mode consists of three possible transpositions; the second contains four symmetrical overlapping groups of three notes, each group containing a semitone followed by a tone, which allows only three transpositions. On the fourth, it returns to the same notes of the first transposition (Fig. 2).<sup>9</sup> The work had four sections, each of which could be moved within the work's linear unfolding. In fact, the work was produced in three separate versions with three separate casts and three separate formats. In the musical transposition, the music's harmonic character remains fixed until a note outside the fixed eight notes, C#, D, E, F, G, Ab, Bb, and B (Fig. 2), is introduced. This makes the ear lean towards an imagined key and its resultant harmonic relationship. For example, raising the Ab to A within this Mode can yield inversions of A Major and D Minor Triads. However, to digress for any length of time puts the composer out of Messiaen's second Mode. In order to stay within it, as the rules of that Mode, the basis



of the whole compositional structure, require, there is a constant shifting between the formal relationships of tonality and atonality. This results in an air of ambiguity, the harmonic relationships tending to give emotional weight and the atonality a distancing effect to the music.<sup>10</sup>

In the choreography, this idea is represented thematically as a shifting between different languages (English, French and Japanese), gender relationships, relationships of conflict, chaos and harmony, and culture, especially in relation to the aboriginal concept of walkabout as the recreation of a special creative relationship to space-time and materiality. My investigation of Messaien's efforts to explore spirituality in musical structures (Messaien, 1956)<sup>11</sup> and my interest in the Australian aboriginal concept of creation as a journey in time by ancestral gods (Chatwin, 1988, Turner 1980) attempted to explore different ideas of dimensionality and interfacing that linked the mythic and the spiritual to the technological. These explorations of different ideas of lived experience continued through *NU* into the six other works mentioned in this thesis.

*NU* (1997), *Octo '15 '97* (1997), *Shango Meets Ogun* (1998) and *Virtual Illusions* (1999) were four works I choreographed using ultrasonic technology. In these works the issue of structure took on another dimension. The movement vocabulary, for example, became looser and more improvisational the more I explored sound and image relationships through technology. The accent shifted from an emphasis on the design of the individual body to an exploration its role as part of an extended body that occupies space and interacts with time. Moreover, I followed the deconstructionist practice of shifting the accent in an analysis of language from its individual use to the larger system that defines the individual. Altogether, this approach gave me a different perspective on the use of speech as a means of embodying choreographic structures. The body became an interactive partner with other objects in a space that was mediated by the technology. Through an examination of Messiaen's harmonic and melodic language as "the bond that exists between music and spirituality",<sup>12</sup> I was able to consider a link between spirituality and technology that links to metaphysics, alchemy and esotericism in the history of science and art.

## 2.6 Some Conclusions

The intelligence of things exists only through what we may call an original fractioning and the comparison of these fractions to one another, which is then only an enumeration of the aspects of Unity. (Lawlor, 1982: 20)

I mentioned previously that an institutionally dictated tendency toward disembodiment in Western intellectual history since the ancient Greeks (Leder, 1990; Foster, 1995a, 1995b) has prejudiced us against looking at body practices as a valid form of knowing. I also argued that prior to, and simultaneous with, the development of Western intellectual history, other cultures recognized the importance of a body-centred knowledge. It may be that the demise of such practices was due to systematic misuse. Whatever the case, it seems important at this time that we pay close attention to the appearance of new forms and take note of our relationship to them. This concern arises from the unprecedented interest in virtual reality, cybernetic entities and “life” in vast computerized networks that threaten to isolate us further from body practices. As a counteractive measure, this research suggests the necessity of a different approach to the body and to performance.

Performance is ritual behaviour essential to individual and community life. This “behaviour twice behaved” or “twice removed” from its original context (Schechner, 2002) reconstructs events of long ago as part of our human evolutionary history. These experiences are “remembered” and reinvented in the context of contemporary social life. Our memories contain data that becomes increasingly difficult to process consciously as we evolve. Over time this data buries itself deeper and deeper into our psyche. Performance is, therefore, helpful as a form of remembering or re-cognizing. It also functions as a modern rite of passage, one that helps us reconcile the notions of inner and outer, self and other, form and content and theory and practice, as inescapable dualities in our world and us.

Philosopher and mathematician René Descartes was not completely off the mark when he claimed that the things of mind (*res cogitans*) are different from those of body (*res extensa*) (Descartes, trans. by Cottingham, 1996). However, he considered mind and body as dichotomous entities rather than states of materiality manifesting themselves as different forms of intelligence. Descartes’ philosophy could not satisfactorily bring together these opposites in a unified theory. Like others before and after him, he underestimated the importance of our bodies as the fundamental subject means of our



being in the world. However, in revisiting his work, we must be careful not to confuse the issues by using the same terms. Cartesian dichotomy suggests a duplicitous polarizing effect while the term multiplicity, for example, suggests diverse universes that balance and reflect one another. The idea of the mind-brain as one central area that dictates and organizes, or around which all other identities revolve, compounds rather than simplifies the problem. A much better way to approach the problem is to devise a new model in the form of a range of core centres around which fundamental functions are managed.

This new model requires that we reexamine individuality and agency within a system that simulates completeness. The human body is a unique learning system that perpetuates itself by recording the same information in a number of places. Because of this, many of its evolutionary processes are slow to appear. However, in such a system, complete communication does not break down if one or two sub-systems malfunction. In fact, the memory of completeness persists in such situations, and the system strives to restore it through behavioural changes. Dawkins (1996) gives the example of the mountain that seems impossible to climb if one looks at it in its entirety. However, viewed as a series of small steps, that mountain can be easily scaled. Dawkins was, of course, referring to biological evolution as a process of extremely small steps over an enormous period, eventually producing complex entities like human beings. My point is that, by approaching duality and opposition as a means of balancing our enormous potential for creativity and destruction, it is possible to transcend the limits of a Cartesian universe.

In conclusion, I would like to return to Lawlor's quotation at the beginning of this section, which refers to the geometrical deconstruction of the Chinese Yin-Yang symbol for the synthesis of opposites (See Fig. 3 below). This symbol encapsulates the reason why an interface is so important, namely, because oppositions and dimensionalities converge there. In it, a large circle splits into two smaller circles based on the single diameter division into two radii. The ratio of the diameter to the circumference of the two inner circles is equal to that of the single larger circle. Continuing this halving of the smaller circles indefinitely, we discover that the sum of the circumference of the smaller circles will still equal the original larger circle. Eventually, a wavy alternating line slightly above and below the original diameter

remains. This reveals an interesting paradox; the diameter of the circle appears equal to its circumference.

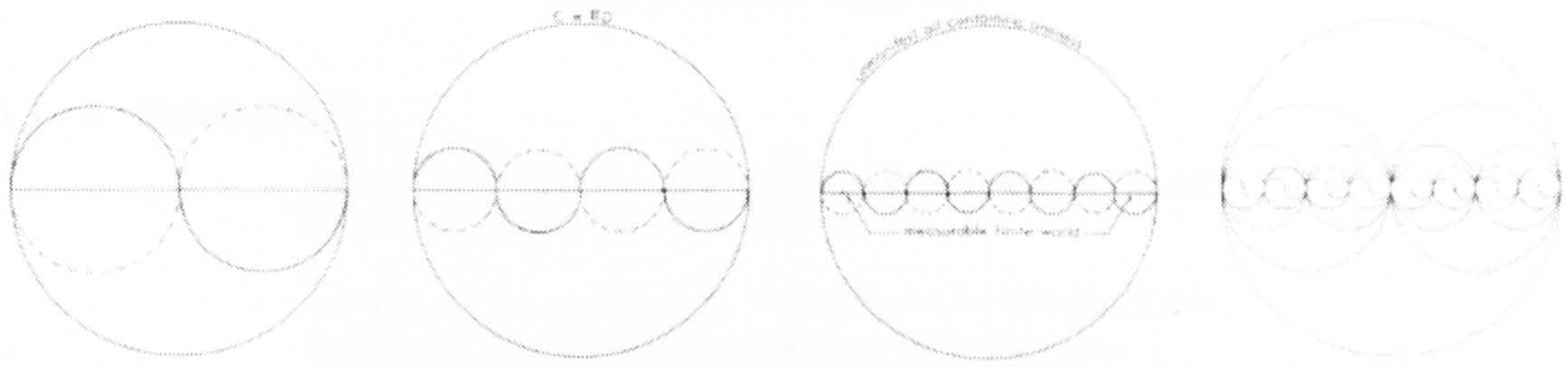

**Fig. 3 - Taoist Symbol (Lawlor, 1982: 42)**

This illustration clearly demonstrates how duality leads to unity, and although the circles may appear to be the same thing, essentially they are not. There is, if one wishes, a hidden tertiary principle that resolves the paradox.



## **Chapter III**

### **Artifice and Intelligence**

#### **3.1 Homo Faber**

Advanced technology is ultimately indifferent to anything but its own expanded use. (Fawcett, 1986: 194)

All technology, sooner or later, gets used to its absolute limits. And technological capability breeds social and political ignorance by seeming to replace knowledge. (Fawcett, 1986: 125-126)

Cybernetic technology is a step beyond mechanical technology, inasmuch as the operator cannot “see” electronic activity at all. Unlike a machine, an electronic device resists intervention. Most electronic devices are black boxes. (Fawcett, 1986: 125-126)

I began this thesis with the argument that technology plays a significant role in influencing contemporary dance and new performance practices. I also suggested that the performing arts, and dance in particular, needs to reposition itself as a stakeholder within 21st-century knowledge-based economies (Kimbell & Perry, 2001).<sup>1</sup> To this end, I identified a role that body practices can play in the evolution of culture, if we consider culture as the “languages, practices, ceremonies, edifices, methods, tools, myths, music, [and] art”, that we engage in (Dennett, 1999).<sup>2</sup> My thesis claims that, faced with the prospect of virtual embodiment for future machine-human co-existence, there is a strong requirement for performance artists to consider their practices as important to new technological societies. Since dance and choreography are my primary research activities, the aim has been to set out a practice-led research strategy with a transdisciplinary perspective that adequately recognizes dance research.

In my general introduction, I mentioned that there are three initial stages to locating the artistic work as a central factor in the research. The first is intention, the second processing and the third contextualizing. I also argued that once a work becomes part of the requirements for an academic degree, a significant difference in intention and approach colours both process and product. Additionally, as one tries to contextualize the work within existing theoretical perspectives, one invariably discovers that the work may not fit exactly. In fact, a practice-based methodology requires in the first place a new perspective on theory. In choreographing the seven works on the DVD “Choreographing Discourse”, my aim was to search for new solutions to the problem

of appropriateness of methodology. As the work progressed, I found it useful to think of the choreographic process itself as a methodological approach, as it is through choreographic methods, procedures and techniques that one discovers new information. In my aim to discover how technology is redefining human performance in dance and other areas where technology influences behaviour, looking at a variety of disciplinary contexts seemed a logical approach. Often, the research pointed towards concepts that helped me as a choreographer to contextualize my work across disciplinary boundaries. This is, of course, precisely what transdisciplinarity entails, i.e., an opportunity to view issues from different perspectives. One such opportunity presented itself when I read a novel by Max Frisch. Technology is “the knack of so arranging the world that we don’t have to experience it” (Frisch, 1959: 178–79). To my sensibility, this quotation suggests interesting dimensions in the relationship between performance and technology.

The source for this text is the novel *Homo Faber*, which is about the life and impending death of Walter Faber, a technologist/engineer. *Homo Faber* is about characters who must make difficult decisions in unpredictable circumstances, decisions that irrevocably change their lives. It is also a treatise on how human beings deny their humanity by reducing the complexity of life to the notion of organization. Although Faber’s performance occurs on the stage of the imagination, it provides insights into the effects that a particular attitude to technology can have on our social and cultural life. Walter Faber, alias *homo faber*, Man the Maker, is a practical man with no belief in providence or fate. He believes only in the formulas of probability. Walter surmises that if the improbable does occur, it confirms that improbability exists at the extreme limits of the probable (Frisch, 1959: 19-20). In Faber’s mind, science and technology can explain and solve all human problems, and one need not look elsewhere for solutions. Frisch inverts the Oedipal myth in high Greek tragic style by presenting the lives of Walter Faber, Hanna Landsberg-Piper and Elisabeth Piper as a series of improbable events occurring in bewilderingly rapid succession. By the end of the narrative, the main characters are either dead, about to die, or emotionally, mentally, physically and psychically devastated.

Philosopher Henri Bergson once argued that there exists a kinship between logical thought and unorganized matter. He claimed that the intellect has a sense of at-home-ness with inanimate objects, hence our innate attraction to technology (Introduction to



*Creative Evolution* Bergson, 1944). According to Bergson, the intellect excels at taking apart technological objects to reveal their components. Consequently, it cannot present the full meaning of life in an evolutionary sense because its primary interest lies in organization. Bergson also believed that memory is a state shared by consciousness, and hence conscious life is an unceasing act of creative activity that preserves the past in the present (Bergson, 1944). For him, the idea of evolutionary life involved far more than a self-organizing system. Indeed, to fit life into such a convenient formula, as Faber attempts to do, devalues it.

In my attempts to define what “life” and the evolution of culture at the machine-human interface might entail, I have suggested using the term performance to describe some of these activities. The ability to reflect on and be conscious of self suggests different performance relationships between human beings and machines. Even though individuals can be self-organized, exhibit agency and be conscious of their actions, they might also behave in mechanistic ways. In other words, human beings can be machine-like at the same time that machines can exhibit human-like behaviour. The question here is two-fold: what defines life and how does our definition influence contemporary attitudes towards computers.

In the last chapter, a great deal of discussion focused on self-consciousness as a distinguishing mark of human beings. This discussion also introduced the issue of agency and will as the twin goals of self-conscious behaviour. In this chapter, I propose that to achieve such a goal, our frame of reference must include the entire phenomenal world, as a complex system that is intelligent and aware of itself, and the role of individuals within it, which includes their recognition of a relationship to that system’s memory. Memory, consciousness and agency are, therefore, key factors for engagement at the human-machine interface. These are the tools that individuals need to redefine their “identity” within this evolutionary body. My contextualization of *Homo Faber* in this chapter, therefore, draws attention to this by problematizing notions of fiction and reality. Fiction functions here to reflect conditions at a particular historical moment. Thus, the “contemporary” reality of *Homo Faber* in 1959, the year the novel was published, exists as a possibility even today. As new technological tools emerge, radical new performance forms and/or techniques that can express the human imagination in more hyper-realistic ways begin to appear, thus contributing to an evolution of culture.

In *Homo Faber*, Walter's existential *angst* results from a disconnected mode of thinking about the world. He does not understand his relationship to the larger evolutionary body. Frisch portrays him trading one stagnant position for another in a futile attempt to escape a constricting set of behaviours constructed by himself. As a result, decisions are imposed on him, which he either submits to or makes absurd choices to avoid. Life refuses to conform to Faber's prescriptive, mechanistic, externally imposed logic, and he never realizes the potential that exists beyond such a view. The main narrative in *Homo Faber* centres on opposing views of life by the characters Hanna, Elizabeth and Walter. Hanna believes that technology engenders a way of thinking that removes the individual from a direct personal experience of the world; a distancing that can have only tragic consequences. Walter believes that looking at life as a mathematical problem is far more useful. Elizabeth, their daughter, lives her life impulsively and dies tragically because of decisions made by all three characters.

Frisch's socio-cultural commentary in *Homo Faber* goes even further by exploiting the idea of technology as male, with a set of behaviours gendered accordingly. We discover, for example, that the female character Hanna "was furious with God for having made boys stronger than girls". In her anger she establishes a secret girls' club prepared only "to consider a heaven in which there were also goddesses" (Frisch, 1959: 192–93). She also vows to be cleverer than all the boys at her school, a position she later regrets as false. She concludes that to join a world just for the sake of survival hopelessly inures one to its contradictions. Hanna interprets Walter's disastrous relationship with their daughter Elizabeth as based on a misconception; he thought he was in love because he experienced a relationship with which he was quite unfamiliar. Such a mistake, she believes, is as much part of him as his profession. She accuses him of treating life as "a mere sum arrived at by addition", with no relation to time and death — a life, she says, which "is not matter and cannot be mastered by technology" (Frisch, 1959: 178–79). Frisch presents Walter's attitude to technology as based on a limited knowledge of the operations of the physical world. He is in awe of technology, blinded by its logic and efficiency, and most of all, its ability to shut him off from meaningful relationships with women.

*Homo Faber* is fiction, but it can be read as an argument for technology as a masculine and alienating force that, faced with an equally inflexible feminine force, ends in



destruction. The character Hanna argues that the technologist's mania for putting the Creation to use because he cannot tolerate it as a partner reveals the need for absolute control behind masculine energy. On the other hand, the woman who embraces life (as Hanna does by deciding not to abort her unborn daughter) is not spared the terrible consequences that life brings with it, experiences that leave an indelible mark on her psyche. Frisch suggests that, willingly or reluctantly faced, suffering is one of the lessons these "lived" experiences teach us. In other words, some memories are embodied through physical "suffering" and revisiting these experiences is difficult. In *Homo Faber*, Walter lives like a machine, never questioning the validity of his actions. However, as he begins to relax this attitude, a newfound irrationality takes over, and he allows himself to experience life as never before. Ironically, this is precisely the moment when tragedy begins to reshape his life.

Frisch's narrative provides a background for seeing reality and fiction as overlapping perspectives that allow us to contextualize memory. Fiction is grounded in reality, in the sense that it is based on a true occurrence. Performance is an attempt to live fully in the present by tapping into the "lived" experiences of humanity's evolutionary past. As I mentioned in my introduction to this thesis, technology has always played a leading role in the theatre as an instrument for the creation of illusion and the enhancement of dramatic action. Pursuing this line of thinking, we can also say that technology allows us to reconfigure memory through performance actions. The crucial point is how we think of and use that technology. To think of it as a tool is useful, but we need to go further and conceive of it as a life form, one that requires us to explore new ways of interacting with it.

The character Faber, as *homo faber*, combines reality and fiction, and represents the human condition. At times the character functions like an artificially intelligent being performing actions for which it has been designed, accurately and reliably, according to a mechanically engineered system of inputs and outputs. However, accuracy and reliability often lead to a denial of one's humanity. Even though *Homo Faber* is fictional, it resembles other "originals" in human history. Greek tragedy is full of such archetypes. Interestingly, Frisch's Faber can be compared, in a behaviouristic sense, to Dennett's intentional systems with their intentional stances. He is "information-modulated" and "goal-seeking" (Dennett, 1996a: 26-27) but governed by "beliefs" and "desires" too narrow for the evolutionary life that Bergson, for example, had in mind.

Frisch's *homo faber* belongs in the category of "anthropomorphism" typical of Dennett's machines.

### 3.2 AI/AL (Artificial Intelligence/Artificial Life)

As the reader may have concluded by now, this study explores the computer-human interface as a physical place, as a concept and as a psychological condition through which our understanding of intelligence, consciousness and agency can be contested. This approach has led me to explore other contexts that at times have little relation to dance *per se* but a great deal to do with the choreographer's approach to the creative process. In thinking of performance as a relationship between human beings and technological machines in real and virtual environments, the reader will notice that these interests have drawn me to look at the "lives" of real individuals, fictional characters, and archetypes in religion and myth. These interests follow from the perspective of technology as a phenomenon that is changing our attitudes to life, reality and culture. Since this research follows a transdisciplinary perspective with a particular focus on dance and performance practices, I find it illuminating to contextualize individuals whose lives reflect these interests.

British mathematician and computer pioneer Alan Turing (1912–54) is an interesting case study in this respect. His groundbreaking paper "Computing Machinery and Intelligence" (Turing, 1950: 433-460) still resonates deeply across a range of disciplinary activities. In this paper, he outlined a test to prove that computing machines could display what he termed "intelligent behaviour" (Haugeland, 1997: 29–56). More than three hundred years earlier, French philosopher and mathematician René Descartes argued that it was impossible to build a machine that could think like a human being. I do not think it was Turing's aim to contest Descartes' claim. Rather he intended to re-examine the basis for a definition of intelligent behaviour. His attempts to design and build a machine that could simulate human behaviour would subsequently launch the field of AI research.

Although singular, Turing was not alone in his efforts. Attempting to automate the task of calculation, Gottfried Wilhelm Leibniz (1623–1662) initiated the field of formal logics (Goldstine, 1972). By constructing a digital machine, Leibniz discovered he could also test hypotheses. Charles Babbage (1791–1871) spent a lifetime trying to build a modern calculating machine. Although his Analytical Engine did not live up to



expectations, he made a contribution to computing that was more legend than accomplishment. Swade (2000) claims that Babbage's failure was that he never realized what many scientists, mathematicians and engineers firmly believed was possible. George Boole (1815–64) helped usher in the binary system of modern computing by formalizing logics into a precise mathematical form, later called Boolean Algebras, which established the formal "language" computers use today. In this language of 1's and 0's, the number one (1) represents the set of all objects being discussed and zero (0) the empty set (Goldstine, 1972). The importance of Boole's work was not fully recognized until the discovery that computers can process information as well as numbers. John von Neumann (1903–57), the "mathematical artist" (Goldstine, 1972), eventually made the first complete analysis of the computer as a logical mechanism. More importantly for this research, he expressed the task of logical mechanical operations as a narrative of human effort. Interestingly, both Turing and von Neumann did important research during the World War II period of intense human effort and suffering. It is also significant that it was through von Neumann that the idea of an intelligent machine took root and the computer was recognized as an important tool for heuristic investigation. The significance of these events is that they led to the development of a technology that would transform society and to humanity's potential to destroy itself, which, to my mind, underlines the importance of technology's ability to create, shape, sustain and destroy cultural life.

Part of Turing's great contribution to science began with his question, "Can machines think?" He problematized this inquiry in his famous test for intelligence. Von Neumann's contribution, on the other hand, was to present mathematics as a form of artistic enquiry that revealed the intricate workings of the phenomenal world. Human beings thereafter began to build sophisticated machines that could emulate that world's beauty. Between them, von Neumann and Turing sketched out a rich terrain for transdisciplinary exploration, a terrain that performance artists would soon after begin to explore from a human-centred perspective.

In the Turing Test, two human beings, a man (A) and a woman (B), are in a room together. An interrogator (C), who could be of either sex, is in a second separate room. A game allows the interrogator to ask specific questions of A and/or B. The interrogator's object is to determine which of the two individuals is male and which is female. The means of communication is a computer terminal or keyboard. A's

objective in the game is to try to cause C to make the wrong identification. Turing then proposes that a machine replace A in the game. His aim was to find out whether the results of the game would be different if it were played between a human and a machine rather than a man and a woman. If the interrogator was unable to distinguish between answers given to the questions put to the machine or the human being (male or female), then the machine was said to exhibit intelligent behaviour (Haugeland, 1997: 29–56). Although Turing devised several different versions of the game, the essential elements in the test remained the same.

Several issues here are important to my investigation of performance practices at the machine-human interface. First, the specific sort of behaviour that Turing chose to highlight in his test was verbal behaviour. His aim was to enable the computer to compete on an intellectual par with the human being via language. Corporeal presence plays no role whatsoever in the experiment. Turing's point was precisely that there should be none. Second, the participants in this test do not communicate directly with one other; in other versions of the test, all of them are in separate rooms. Hence, the measure of intelligence was to verbally express oneself in a coherent manner at a distance. Third, replacing an individual with a machine means the remaining person or persons communicate with a machine as an interactive performance partner, an issue at the core of our relations with new technology.

My fourth point deals with the fact that three people of two different sexes participate in this version of the test, one of whom is eventually replaced by a machine. Turing's argument that a system is intelligent if it can carry on an ordinary conversation like an ordinary person suggests that gender, along with other physical characteristics like tone of voice, physical appearance, are not necessary to determine intelligence and/or to influence a person's judgement. We can speculate that such a neutering of personality may have been a strategy for removing gender biases. However, in other versions of the test gender did not overtly appear to be an issue. The fact that Turing's sexuality caused problems in his professional life may have influenced his casting decisions, but he never officially framed sexuality as an issue. The fact that it was a problem in his personal and professional life makes it relevant for us because it demonstrates how personal and institutional bodies come into conflict. While the professional institutions could not condone Turing's private and unconventional



behaviour, they badly needed his expertise at a time of international crisis.<sup>3</sup> This, therefore, was the reason behind Turing's acceptability as an individual.

My fifth point combines the previous four. It refers to society's unwillingness to accept others who do not fit in with the norm. Turing may have contemplated a gender-less identity or sexual anonymity from a personal point of view, but we do not know this as a fact. What is fact is that he formulated an experiment that problematized a set of related issues. The above arguments look at the Turing test from a new perspective, not apparent at first but important to our understanding of bodies in performance at the computer-human interface. Turing's life can be seen as a study in the socio-politics of intellectual "blackboxing" that Mario Biagoli refers to in his article "Tacit Knowledge, Courtliness, and the Scientist's Body" mentioned earlier (Chapter II, 2.1 & 2.2.) His "inappropriate" private self conflicted with the conventions of scientific pursuits. Investigated and ridiculed for his private behaviour and lauded for his scientific accomplishments, he was as enigmatic as the secret German submarine code he successfully helped decipher, and which eventually contributed to the end of the Second World War.

### **3.3 Intelligent Machines**

The machines that Leibniz, Babbage, von Neumann and Turing contemplated were not capable of the awareness and/or intention that human beings possess. However, an underlying aim in each of these men's work was to enable machines to "learn" from human actions so that the machines could perform actions controlled by human beings. This aim led to the need for larger memories, more accurate programming languages and the ability to make accurate decisions given the right processing power. Human beings became the prototype for new computing systems that would simulate not just our patterns of thought but our physical behaviours as well. To put it another way, a process of artificial embodiment replicated into a silicon-based substrate the memory of organic life on earth. The "post-human" experience that many predicted (Pepperell, 1995; Kurzweill, 1999) began to challenge our biological and genetic given as well as the human being's position on the evolutionary ladder.

Turing's assumption that a machine could theoretically carry out any possible computational task if it had an unlimited calculating and storage memory appeared to be realistic. With modern computing power exponentially doubling every eighteen

months,<sup>4</sup> many now believe that we will eventually have the capacity to create a completely different world and the requisite beings to inhabit it. This, I believe, makes it all the more important for us to visualise the machine-human interface as the most important site where new transformatory practices will occur. I argue that such interfaces have, in the past, always been sites for radical cultural change and will continue to be so in the future.

As I mentioned previously, this research looks at the “lives” of real individuals, fictional characters and cultural archetypes in its attempts to examine the computer-human or machine-human interface as a physical site and a conceptual idea. At this interface, a variety of hybrid forms undergo processes of radical change. To facilitate a transformation, acts of performance are required. In the past, among various cultures, such practices allowed people to transform themselves and to cross barriers that would otherwise stop them. In doing so, they gave up their ordinary identities to become “hosts” for other, arguably “superior”, identities.

Throughout the African Diaspora, for example, among descendants of the Yoruba people, ceremonial practices involve an initiate who is mounted by an “Orisha”, one of the many emissaries of Olodumare, the supreme God of the Yoruba tradition. These Orishas, or divinities, represent nature’s archetypal forces that govern the endeavours of humanity and help to maintain the structure of the material world. To many, these are primitive practices, but I would argue that many of our contemporary new media practices fall within a similar category. In fact, *Shango Meets Ogun*, one of the works on the DVD “Choreographing Discourse”, examines how new technologies can contribute to a re-examination of cultural perspectives and practices that frames reality within an African diasporic context. Although one can argue that contemporary media culture is rapidly assimilating the practices of ritual theatre in the same way that ritual theatre assumed some of the practices of so-called primitive peoples, *Shango Meets Ogun* proves that positive relationships can be explored through such practices.

In many ways, technology is creating its own ritual theatre in the form of an Internet-based virtual culture. Millions of people are drawn to this “performance” space every minute of every day. However, much of this activity involves the body in limited and sometimes injurious ways. In dance, for example, the performer intuitively “knows” that the body is the means for experiencing the world. Many people who work



extensively with technology seem not to be aware of the importance of this fact. Perhaps if they realized that we are part of a larger physical system and that we are obliged to contribute to that system's ecological balance, then body practices would assume greater importance in maintaining the system's overall health. In other words, the technologist would be more aware of a human ecology in addition to an environmental ecology.

For another example of a tradition-based cosmological system in which ecological balance has credence, this research looks at the Kwakiutl, one of the many indigenous groups or Nations of Canada's northwest coast. The Kwakiutl are a people whose tradition binds them to a cosmological system that rules their social life and pervades their understanding of the world. Unfortunately, as in other indigenous cultures, Western ideas have rapidly encroached on the Kwakiutl domain. However, substantial remnants of their beliefs persist. Walens (1981) claims that for the Kwakiutl

The universe is a place where some beings are eaten by other beings and where it is the role of some beings to die so that other beings may feed on them and live [...] Food provides for them a model of the nature of life; [...] and the food chain itself provides the link between one human and another and between humans and the rest of the world. (Walens, 1981: 12)

Walens argues that metaphors of assimilation and eating provide the cognitive model underlying the Kwakiutl understanding of the structure and process of their universe. He claims that most anthropologists have overlooked this fact and, in the process, have misrepresented Northwest Coastal Cultures. What may appear as a primitive way of looking at the world is in reality a cohesive representation of it. Eating is not simply the gratification of a stomach-based hunger but also the means to acquire sustenance for different planes of existence. Since food, water and air sustain life and since we would not live long without them, the idea of impressions as sustenance for a different kind of body is not difficult to imagine (Ouspensky, 1983).

The Kwakiutl and other ancient cultures firmly believed that human beings maintain the existence of the phenomenal world through their awareness and reaffirmation of it. They knew that impressions were as important for their existence as food, air and water. They also believed that life was a cyclic process and that individuals became what they ate and/or were eaten by. Theirs was a world full of intelligent sentient beings, with and without visible material forms, through which everything was linked

by a chain of reciprocal feeding. This notion of an environment in which everything is alive and aware of everything else, according to that entity's degree of intelligence, is no more outrageous than Dennett's (1996a) attribution of life to machines through what he calls anthropomorphism or the pronouncement of AI specialist Ray Kurzweil that the future evolution of human beings lies in silicon-based bodies (Kurzweil, 1999). The point is that intelligence and life can also be described in non-human terms.

Cognitive scientist Steven Pinker describes intelligence as a product of information, and information he describes as "a correlation between two things that is caused by a lawful process." Correlation he further describes as "a mathematical and logical concept" that is "not defined in terms of the stuff that the correlated entities are made of" (Pinker, 1998: 65). Pinker's point is that information is present in everything and is embodied in symbols. Any entity, regardless of nature or character, can act as a symbol, and when these symbols combine in relationships with each other, they can be used in a rational way to produce true conclusions from true premises. This process, he implies, is what constitutes an intelligent environment.

### **3.4 Embodying Information, Embodying Life**

Turing put the computer on a competitive par with the human being by re-examining notions of intelligence in a completely different context. He called this form of agency Artificial Intelligence. One of the main goals of AI became teaching machines how to learn by using feedback loops or servo control systems. A servo system uses information gathered from a machine's output to modify its activities. Human beings have used the same strategy as a learning and survival mechanism throughout their evolution. Servo control differs in human and computer systems in that the latter is a non-organic network that is not self-generating. These networks display qualities that are lifelike, but it is a different kind of life than the human. The level of complexity currently required to enable a machine to feel, think and act as a human being is impossible. However, significant steps are being made in simulating some types of behaviour from movement (Gray & Caldwell, 1996; Lenarcic & Thomas, 2002) to speech, language and thought (Hutchby, 2001; Cangelosi & Parisi 2002; Mitkov, 2003).



Computers are only just beginning to mimic the remarkable capacity for self-organization that human beings innately possess. However, they must be programmed to accomplish this. Human performance entails a dynamic transfer of information from one place to another, information that is re-organized and re-presented through individual agency. Choreography, as an organized system of movement actions performed by human beings, can be a form of rearticulating and regenerating life. Dance, therefore, gives us an opportunity to witness life in organized environments and the chance to relive or reorganize our own experiences within new frameworks. Choreographer William Forsythe claims that choreography is about organization: “either one is organizing the body, or [...] organizing bodies with other bodies, or a body with other bodies in an environment that is organized”. He argues that this is what “seems to be the challenge of choreography at the end of the twentieth century” (Forsythe, 1996).<sup>5</sup> This research claims that such a perspective locates the human being not as the focus of creation but as an important partner in it. Extending one’s intention and conscious thoughts beyond one’s physical body into other dimensions of being becomes one of performance’s main goals.

Since performance is a way of negotiating different dimensionalities of existence, and consequently different kinds of bodies, the notion of a distributed existence within a larger evolutionary body comes into its own. A transdisciplinary exploration of the body, of performance and of technology also seems a more appropriate approach. Pepperell (1995), for example, argues that in four-dimensional processes thoughts and memories are not fixed in time and space. He claims that they are distributed throughout the body, not just localized in the brain, travelling from the head to the foot along neural pathways and through the body’s nervous systems, initiating chemical reactions along the way (Pepperell, 1995: 85–86). Pavis (Berghaus, 2001) asserts that our ways of looking are both conscious and unconscious and our thoughts possess a certain “psychic corporeality”, a kind of “spectator’s body”. Biologist Steve Jones claims that fundamental links exist between biological evolution and the evolution of language, and the proof lies in the letters of our DNA (Jones, 2000). He argues that these are coded instructions on how to make a human being. Both language and genes evolve, and just as our modern genes are variations of those from our distant past so are our languages. The two form an essential part of humanity’s collective memory, a blueprint of the history of our existence. Like the computer’s language of 0’s and 1’s,

the genetic code is a discrete digital system. The identity of each of its letters and their particular configurations are definite, even though individuals are different. We are, therefore, both analogue and digital flesh, and like the computer's 0's and 1's, C, G, A and T represents definite states of information inherent in the identity of the letters themselves.

In summation, I propose that we look at the meaning of existence for *homo faber* as a history of the body's formation since as human beings we are the history of our species' thoughts, actions and expressions. Even though a large part of us is a consequence as well as a function of brain activity, we are significantly more than the sum of our brain's mechanical operations. Even though there is a duality of purpose in human beings that is reflected in how we think, feel and act, this is by no means a negative position. In fact, since everything, including consciousness and self-awareness, develops out of processes of opposition and conciliation, this can be viewed as a positive potential. We are human beings but we also operate like machines with extremely sophisticated programmed circuits. Turing's formulation of a theoretical machine with the ability to have input and output symbols that corresponded exactly to each other did not fully take into consideration that these symbols had physical properties, and that they could interact with other symbols to produce a corresponding true outcome. Since there was no inherent meaning attached to their actions, these machines were classified as artificially intelligent: they could implement any conceivable computational instruction, given an unlimited memory supply. However, in the case of human systems, the value of these symbols was crucial in interpreting human behaviour. As the initial goal of AI was to develop intelligent systems modelled on the human mind itself, researchers found it necessary to treat the human being as a complex and distributed physical system that operates under certain performance conditions. I have argued that this is insufficient ground to account for the concept of will in human beings.

In spite of this insufficiency, technology allows people to rediscover notions of performance that go far beyond the articulation of a biological body in front of an audience that is located in the same space and views the event at the same time as it takes place. New technologies define and simultaneously polarise notions of bodies into extremes of *virtual* and *real*. Modern dance has arguably used the biological body and its social conditioning for much of its thematic. As digital technology introduces



new concepts of the body that challenge the way we see and think, new types of bodies and forms of dance and performance practices appear. Thus, when computation augments dance, the performer's physical actions, the computer's activities and the performer's thought processes become its most important ingredients. If the performer's physical actions are reduced to almost nothing, a performance that arises from mental activity and computation tightly integrated would remain. In such a situation, viewers would have to depend on their ability to re-cognize the series of actions from specific behaviours they can validate from their own memory. Whether viewers can access this memory is altogether a different issue.

### 3.5 Choreographing Discourse III

As Western musicians and dancers often ask when learning music or dance with me, "where is your one?" means when do we start the rhythm? At which point? My ability to change the rhythmic structure within established patterns while purposefully and constantly ignoring a fixed point of departure refers in fact to a tradition that constantly integrates all elements of life within a rhythmic context (hence the necessity of dance) that transcends them at the same time such that separating these elements from their "dancing context" would seem arbitrary (hence the meaning of dance).  
(Maboungou, 1997a)

*Octo 15 '97* (1997), *Shango Meets Ogun* (1998), *Virtual Illusions* (1999), *Relatively-Well-Centred* (2000-2001) and *Out-of-Body* (2002) are five works that attempt to establish important interfaces between culture, technology and performance. In choreographing these works, my aim was to allow the pieces to evolve as a direct outcome of a search for an appropriate methodology. As I mentioned previously, this led to a realization that the choreographic process itself was a valid methodological approach, as a series of methods, procedures and techniques led to new information. As I began to use these technologies and to observe new connections between different disciplines, transdisciplinarity seemed a logical choice as a framework.

However, as I explored this avenue, it became apparent that there was an even larger issue involved. This was the issue of connecting not only disciplines but also a range of ideas with different genealogies across historical periods, cultural contexts and notions of existence. In short, a concern for practice as the basis for a research strategy led to an understanding of the relationships between bodies of knowledge. At this point, it became clear to me that there were other aspects of transdisciplinarity that I had not considered, namely, the ability to connect bodies of knowledge across time,

space and disciplinary constraints. London, Bristol and Winchester in the UK, Vancouver in Canada, and a number of points in between formed a physical map indicating the location of information as well as how they could be processed. The seven performance works outlined and negotiated a set of relations between types of bodies distributed across different locations and perhaps space-time dimensionalities.

Each of these works deals in some way with issues of identity — cultural, personal, societal and professional. The issue of re-cognizing memory has always been present within the context of my African cultural background, my professional career as a performer and my sense of belonging developed by living among different cultural groups in a variety of European, North American and Caribbean countries.

Concurrently, there has also been the issue of assimilating perspectives quite different to my own. In the effort to “look” in at least two directions at the same time (Gilroy, 1993), I came to appreciate the notion of “distributed centring”. Although this idea has long existed in West African culture as a relationship between the human and the divine, “double consciousness” acquired a different significance when African culture met European culture as it did through the experience of forced enslavement via the Middle Passage.<sup>6</sup> However, a body that is subdued to accommodate one “host” can also accommodate or play host to multiple cultural perspectives if some basis for this accommodation is established. Subsequently, the need to establish such a perspective in my research, and to integrate this with the methodology, became an important issue for me. A new interface thus appeared.

The idea of an interface that was introduced in Chapter II was an abstract one. In this chapter, I explained that the Chinese Yin-Yang symbol expressed a paradoxical relationship between the circumference of the circle and its diameter. Conceptually speaking, the relationship between diameter and circumference outlines a space where different dimensions of reality converge and where bodies within that space, and/or perspectives on reality, can be transformed through acts of performance. Since different dimensionalities of existence also converge in the human body, one can say that in its “diameter” and “circumference”, the human being is multi-dimensional and inherently paradoxical. This makes our behaviour quite complex and difficult to understand, unless we look with a different set of eyes. The above-mentioned five works, and indeed all of the DVD “Choreographing Discourse”, are attempts to explore multidimensionality and transdisciplinarity by bisecting and/or deconstructing



space, time and experience with the assistance of various computer-based technologies.

In the first two works, *Octo 15 '97* and *Virtual Illusions*, sound sensors locate the dancers' movements, which in turn control the animation and colouring of a mix of computer-generated graphics, synchronous images of the performer, film clips and still images. The third, *Shango Meets Ogun*,<sup>7</sup> features an interactive environment where choreographed movement phrases, live and recorded vocal texts, pre-recorded video extracts, and programmed sound samples were modified and mediated via ultrasonic sound sensors. This piece was devised, improvised and choreographed around the "lives" of two divinities or *Orishas*, Shango and Ogun, from the West African Yoruba tradition.<sup>8</sup> In *Virtual Illusions*, a "commentary with variations on Virtual Reality devised by Brian Johnson with choreographer/dancer Henry Daniel as the protagonist"<sup>9</sup>, the narrative revolves around a homeless character who discovers a pair of Virtual Reality (VR) glasses and stumbles through deranged dreams, the carnival of his childhood somewhere in the Caribbean. At the end of a virtual reality epiphany, the character drags himself out of the meaningless hole of a decrepit existence. The fourth work, *Relatively-Well-Centred*, uses a variety of literary texts by well-known writers (Woolf, 1963; Angelou, 1997; Kafka, 1967; Condé, 1992; Miller, 1981) to explore notions of distributed identities, of corporeal centred-ness, and of phenomenologically being in the body.

The overall aim in creating these works was to follow an intention, develop a set of processes and then attempt to contextualize them in relation to established procedures. These steps, I felt, would inevitably lead to a clear definition of a practice-led research methodology, the formulation of a theoretical basis for the work, and the development of a critical framework in which it could be assessed. How this all comes together is the subject of the following chapter.

## Chapter IV Choreographing Discourse

### 4.1 Re-cognizing Memory

Scholars are fond of saying that dance is an ephemeral art form, meaning that it is not fixed in space and time as, for example, a painting or a novel. These arguments focus on a performance as a live event that captures a particular state, which disappears as soon as the event ends. Even though a notation score or a video remains, the live experience is gone. I argue that ephemerality is a relative concept, for even as that live, physically embodied dance may seem to exist only in the moment, when the event is over, its traces are left in bodies, in space, and in other media involved in the event. The five works briefly described at the end of the last chapter, *Octo 15'97* (1997), *Shango Meets Ogun* (1998), *Virtual Illusions* (1999), *Relatively-Well-Centred* (2000-2001) and *Out-of-Body* (2002), explore the idea that bodies absorb knowledge held only in fragments in our conscious memory. Thus, performances are unique opportunities to remember or recognize a “history” of events, deeply embedded in memory, which tends to emerge under certain conditions.

In attempting to re-cognize or reconstruct memory, cultural or otherwise, there is always the risk of crossing into the terrain of fiction. In short, one is never quite sure of the border between truth and falsity without hard evidence to support one’s position. However, since the creative artist challenges historicity by taking liberties with truth and fiction, sometimes the only hard evidence we have is the body and the memories it holds. Hence, bodies and their environment provide all the necessary data an audience needs either to agree or disagree with what they see on the stage. How that data is interpreted can reveal a great deal about each individual audience member. My research does not extend into the area of audience survey. However, it attempts to set up its own system of codes as a form of “disciplined subjectivity” (Biagoli in Foster, 1995a: 69-81) that also refers to existing dance techniques and movement styles. Scientific rigor can thus be exercised and proofs verified through the replication of certain processes. I mentioned in Chapter II that since each dance performance offers a new and different experience, replication does not mean identical results each time a performance is repeated. Rather, one attempts to replicate a specific procedure, which



can reveal new information about the performer's nature and identity, the audience member, the performance environment, as well as the methods and tools used.

My approach here is to look at the collected data from as many perspectives as possible and to draw conclusions from it. However, I also leave it up to the individual audience member to interpret the same data according to their own experiences. This approach is extremely important because a performance can be truly validated only by the audience that views it and the individuals who perform it. The classic triangle of actor, event and viewer must exist. My gathering and subsequent framing of that data is, of course, important, but the more important issue is that such a framing is just one possibility among many. Since what individuals perceive is also validated by their own experiences, one other way of sharing that experience comes later through discussion. The relationship between fiction and reality, therefore, means little to me except in my relations with the other performers and with my audiences. In fact, the artist as actor or performer forms a different relationship to fiction than most people: they assume a role or become specific characters for the duration of the performance. Hence, truth and falsity are relative to how believable one's character is. This is a rather contentious position to adopt, but in light of my experience as an artist, I can assume no other position that will allow me to mount a credible argument.

I became aware of the many possibilities for exploring the relationship between fiction and truth in performance while choreographing *Octo 15 '97* for a performance at the old Leadworks in Bristol. This work also helped me to establish a theoretical perspective for "content" that was beginning to emerge in the research. The Leadworks stood a site marked for demolition in 1998 to make way for a new performance centre, part of a larger Millennium project intended to modernize the city's dockside area. My plans for the work involved preserving that performance's specific characteristics, from that specific day and specific place, in a different medium, i.e., the Internet. In this way I could reproduce in cyberspace an event that took place in a physical structure that no longer exists. More importantly perhaps, I was interested in the possible relationships between the geography, archaeology and psychology of memory in relation to physical spaces.

Bristol is a historic city, an old slave port that lost its trade to Liverpool, which is more advantageously located for the ships that transported cheap mass-produced industrial

goods from England in exchange for slaves from West Africa. Its architecture is impressive, and some of its older buildings reflect an earlier period of history. Even though Bristol profited from the Atlantic Slave Trade, many of the city's wealthy inhabitants still hesitate to admit this. As such, the Black contribution to the history and culture of Bristol took a long time to be acknowledged. Cities like Bristol, Liverpool and London benefited immensely from the cultures that entered through their ports and took root in many parts of England. I became interested in these cultures' journeys through England, and the possibilities of retracing them through performance. When I walked the streets of these cities and examined the architecture, I left my imagination open to their existence as hard factual evidence. What additional facts were available I tried to assimilate. Eventually, I speculated on how these facts related and attempted to piece them together in an imaginative performance. The point was not to reproduce facts but to arrive at a level of truth that was located in bodies. In this way audience members could "read" what they perceived as well as experienced.

While I was working through these ideas, an American who was researching the genealogy of her family contacted me. She had traced old records from a ship that left the port of Southampton and travelled to America via a sugar plantation in Barbados. Since I shared that her family name and was of Caribbean origin, I found the coincidence interesting. However, I did not give it further thought at that point. During the preparation of *Octo 15 '97*, I found the technology we were using somewhat overwhelming at times (there was a proliferation of wires, speakers, screens, cameras, synthesizers, mixers, samplers, consoles, computers, etc. in the performance). At other times, I felt like a creature in a Kafkaesque technological zoo. As the low-level output CCT (Closed Circuit Television) cameras recorded the crude motion-capture sequences, the eerie disembodied figure in the monitor that stared back seemed to reflect a strange kind of torment. Further along, as the work progressed, I would often feel overwhelmed by the didactic nature of technology, i.e., by the sound sensors that determined where and how I should move. During the performance of the work at the Leadworks, I remember having a distinct sensation that I was in another Bristol, an 18th-century one, after a long transatlantic journey, my freedom to move curtailed by different constraints. The power of that associative moment was intensely physical, making it clear to me that the time and space of these two events, one "imagined" and the other "real", were at that moment simultaneously present and true for me.



This experience is reminiscent of a condition that psychologist Carl Jung would probably refer to as synchronicity, an acausal principle that links by coincidence events with a similar meaning (Jung, 1969, 1978). As part of the recent history of the people of my race, the performance allowed movement actions in my body to trigger the memory of movement actions in another body from a different space and time. To my mind, the question of reality and unreality was of little consequence at that point. More important was the link made through the performance event at the Leadworks to an experience, with repercussions on the psyche of others like myself, relevant to me as the descendant of slaves. I am also reminded of a conversation between choreographer Bill T. Jones and writer Anne Daly in which Jones talks about pure abstraction as opposed to narrative as an aesthetic in his work. In this conversation (Daly, 2002), Jones claimed that it was impossible for him to achieve pure abstraction in his work because of his cultural background. In other words, as the offspring of African American slaves he could not put aside a set of natural inclinations in favour of pure abstraction.

How can I — a person who was a child of slaves, a person who was abducted, brought here, force-fed religion, culture, values, denied education, denied my “true heritage” as an African person — how can I ever expect to take part in this quest for purity, because the question arises: whose definition of purity? There we have taken what was basically an aesthetic discussion into the realm of politics and the kind of emotionalism that follows. This has been the dance that I have been dancing the whole of my creative life. (Daly, 2002: 70)

The purity he refers to here is, of course, the abstraction that choreographers like Merce Cunningham espoused and which, Jones argues, can never emerge from him, however hard he tries. In other words, he cannot escape the social, political and cultural readings that his identity contributes to the work.

Jones is one of the post-Judson generation of dancer/choreographers fascinated with the ideals and aesthetics of Modernism, willing to give these renewed life through new technology. His style is different from that of members of the Judson Church group of the mid- to late 1960s, like Douglas Dunn, Trisha Brown and Yvonne Rainer, even though he actively explored some of those ideas. As a black gay male dancer, Jones was well acquainted with the gender and social politics of his situation. Both he and his partner and co-choreographer Arne, a white Jewish male, relied on these aspects of their identities in their work together. When Zane died of AIDS in 1988, six years after

they had formed the multi-national and multi-racial Bill T. Jones/Arne Zane Dance Company, a devastated Jones embarked on a new direction in his work that was characterized by loss, grief and anger.

In what I describe as a crisis of the personal body, Jones began to analyze the body politic, the society that he had once mischievously toyed with, sometimes for his and Zane's own amusement, with a rage and determination to right what he felt were endemic wrongs. The Bill T. Jones/Arne Zane Dance Company became a platform for social commentary. In his memoirs, *Last Night on Earth* (1995), Jones senses he may have little time to live and is prepared to act quickly and radically. Although his duets with Arne Zane were often intended as a movement semiology that had "a musical and sculpturally constructivist slant" (Daly, 2002: 79), his audiences saw otherwise. In *Ghostcatching*, a post-Arne choreographic work that uses motion-capture technology to create a virtual body, Jones reconfigures his work in a new context defined by the relationship between his real and his cybernetically envisioned body. Cyberspace became a place where he could reassess his humanity, or rather that of the creature that seemed to want something.<sup>1</sup> I believe that this form of abstraction of his dancing personality in a set of motion-captured images had a distancing effect that allowed Jones to reflect on his identity from a new perspective.

My own choreographic explorations with *NU* that led up to *Octo 15 '97* followed a similar journey from abstraction to the emergence of a narrative that, in many ways, was not consciously sought. *Octo 15 '97*, and subsequently *Shango Meets Ogun* (1998), *Virtual Illusions* (1999), *Relatively-Well-Centred* (2000-2001) and *Out-of-Body* (2002) became a platform for my idea that bodies absorb knowledge held only in fragments in our conscious memory. The opportunity to perform released some of that information to the extent that I was able remember or recognize a "history" of events, deeply embedded in my cultural memory. Hence, a new challenge to historicity began for me as a creative artist through taking liberties with truth and fiction, finding justification in the hard evidence that my body and the bodies of many blacks in the diaspora still holds.

## 4.2 Paradoxical Bodies

The results of choreographic research are not always obvious until after the work is completed, performed and assessed. In fact, I would say that a period of reflection is



necessary in order to understand what connections took place during the performance. This is an important point, as performers can identify so closely with the performance that their take on reality can differ radically from that of others. More importantly perhaps, the performers constant negotiation of the reality-fiction interface blinds them to the fact that others may not understand how or why performance might be a necessary activity. There is, if we can put it this way, a paradox of performance: one can often “remember” a great deal about peripheral details when one is performing but forget a great deal about one’s immediate condition. It is not unusual for performers to say that they were “in another world” during a performance, a world where it is impossible to maintain a relationship to present time and space, but from which new experiences of time and space are possible.

In *Out-of-Body* (2002), a short work I choreographed for the CBC (Canadian Broadcasting Corporation) pilot program “ZeD”, I revisited this idea of an inter-space where one could reconstruct and/or influence memory. This revisiting allowed me to contextualize the experience of *Octo 15 '97* from a new perspective. The literary text for *Out-of-Body* is taken from *A Map to the Door of No Return* (Brand, 2001), Trinidad-born Canadian writer Dionne Brand’s exploration of identities that have been arrested, lost or misplaced after a passage through a metaphorical door. This passage, she claims, has resulted in an inability of the diasporic African to completely reorient him or herself in a New World Western European environment. Brand lives in Toronto, where there is a large African diasporic population.

Nigerian writer Wole Soyinka deals with a similar idea of psychic displacement in his essay “The Fourth Stage: Through the Mysteries of Ogun to the Origin of Yoruba Tragedy” (Eze, 1998). Soyinka claims that the tragedy of Ogun, the Orisha who came to Earth on a mission to assist humans, occurs when he does not realize where and who he is.<sup>2</sup> He also argues that the search for the meaning of tragedy in general depends on the human being’s recognition of what he calls “certain areas of depth-experience”. Since these experiences are not satisfactorily explained by conventional aesthetic theories, we are forced to return to our own indigenous sources. According to Soyinka, traditional Yoruba tragedy is “the anguish of [...] severance, the fragmentation of essence from self” (Eze, 1998: 440). This anguish of severance is compounded by a forced transatlantic journey, where both physical and “spiritual” bodies are set adrift.

By spiritual body, I refer to a set of culturally specific beliefs and practices that orient the individual to a particular conceptualization of space and time, which promotes a well-defined sense of identity and belonging. In Yoruba culture, these identities are structured around the idea of the *Orishas* who, as I mentioned in the last chapter, are divinities or archetypal forces of nature that govern humanity's endeavours and help to maintain the material world's structure. In *A Map to the Door of No Return* Brand argues that the notion of returning is impossible in the context of Africans who were taken by force from their homeland, punished and deprived of the right to practice their beliefs, rites and rights of passage. Brand implies that progress must come via another door, a virtual one that exists at the original place of juncture. She claims that new identities are possible through such alternative openings or inter-spaces. These new identities can be reshaped from one's "lived" experiences, from those inherited from a cultural past, as well as from those gained from another space that Brand's invisible door opens into. This inter-space implies that there are memories of "others" available as awarenesses that an individual can tap into. *Out-of-Body* is a short choreographic meditation on Brand's vision, one that is just long enough to draw attention to Paul Gilroy's vision in *Against Race* (2002).

Gilroy's argument in *Against Race* is complex. He claims that African Americans see Africa as the symbol of a freedom they were denied for over two hundred years. However, African Americans are quite different from contemporary Africans, and even though an inescapable bond exists between them, African Americans are often mistaken about this relationship. Gilroy is British, born in England of Jamaican parents; Brand is Canadian, born in Trinidad of Trinidadian parents. Brand writes about the door of no return as "a place emptied of beginnings", "a site of belonging and unbelonging" (Brand, 2001: 5–6). Gilroy writes of current conceptions of race as a substantial barrier to establishing a new vision of social relations within the Diaspora and with white Americans. *Against Race* is concerned with not letting the issue of race cloud relations between individuals. Brand speaks of having no name and no past, and of this lack as a fissure between past and present, a place where our ancestors departed one world for another. The New World that these writers allude to draws attention to what may lie on the other side of this metaphorical door. In light of Gilroy's optimism and Brand's realism, I question how far this desire for a New World resonates with or relates to the virtual world of technology. To me there is a clear connection.



Technology, with its virtual world and cybernetic creatures, seems to me a new reality that is the result of a communal “dream” influencing the future of all cultures.

The DVD “Choreographing Discourse” graphically represents the idea of doorways and/or alternate channels through which other tracks of memory can enter. Three works, *Octo 15’97*, *Shango Meets Ogun* and *Relatively-Well-Centred*, use the multi-angle feature in most DVD software design technology to actualize this. These three works also use a motion-capture sequence recorded at the Elektrodome studios in Bristol, which depicts, in virtual space, the same disembodied character mentioned above. The third work, *Relatively-Well-Centred*, explores the notion of a being centred between worlds, dimensionalities and/or locations. In this piece, “screen” dancers shadow the “live” dancers in a cultural counterbalancing act. The ability to switch channels, to view or hear information from a parallel source, emphasizes the notion of alternate realities.

As I mentioned before, my point was to underline the idea of a complex body that exists simultaneously in different spaces and to explore the possibility that a performer might access the different realities that these bodies represent. I call this process corporeal re-cognition, linking it to the notion of the “lived” experience that is defined in phenomenology. My point was also to underline that whatever findings emerged would be contentious or even fictitious. My role as a performance artist was to problematize memory and history as the result of the “lived” experiences of bodies defined by a set of culturally understood parameters.

### **4.3 Dislocated Bodies**

In the Yoruba and many other Black African cultural groups, an idea deeply embedded in people’s psyche manifests itself in everyday life as well as in their performance actions. This idea is that human beings are connected to other entities that exist in spaces outside the everyday. Although these entities obey entirely different rules than ours, their influence extends to all aspects of our everyday life. They also help humans in need, entering our ordinary world through the individual undergoing a performative experience. In the West African context, there are three different worlds: 1) that of the Living, 2) that of the Unborn and 3) that of the Ancestors. At the gate to these worlds stands the trickster Eshu, the two-faced Orisha who plays terrible tricks on human beings. Eshu guards the passageway to the vital life force the Yoruba call “ase” or

“ashe”, which means “so be it” or “may it happen”.<sup>3</sup> He is the guardian of the threshold between the physical and spiritual realms.

There are variations of the tripartite division of the world or of the dimensionalities of existence among different West African groups, but the overall pattern is the same: intelligences with particular responsibilities inhabit three physical and conceptual spaces, each with their own rules. To implement their responsibilities, these intelligences interact with human beings from time to time. Even though movement between worlds is possible, a fixed protocol and specific rituals govern these movements. Human beings may aspire to these spaces, but they can only get there through the benevolence of these intelligences, who may prove to be quite fickle. Entities may also travel between these worlds, but they must first be summoned by human beings with ritual offerings and gifts. These rituals have a specific format that must be strictly followed. The *Candomblé* of Brazil, the *Shango* religion of Trinidad, the *Santeria* of Cuba and the *Voudou* of Haiti are examples of such rituals. In these ceremonies, the devotee’s body is “mounted” by another agent or *Orisha* who allows the devotee a particular insight. Through the intercession of these agents the individual accesses knowledge from the ancestral plane to, for example, convey this information to the community that shares such beliefs and practices.

Although parallels in a Western context exist (the Greco-Roman mythology with its pantheon of Gods, for example), these *Orishas* oppose the white Western cultures that blacks were forced to adopt during the African slave trade. Nevertheless, these same blacks were instrumental in helping the rituals and practices of Christianity to absorb many of the rituals associated with these deities, creating a new and complex system in many areas of the New World. Shango, for example, resembles Jupiter or Zeus as the God of thunder,<sup>4</sup> and Ogun the Roman Vulcan or Greek Hephaistos, God of iron and the forge.<sup>5</sup> Both are associated with the Internet and cyberspace where iconic and symbolic tools merge with powerful archetypes to form a psychological reality that operates at an unconscious level.

The psychological implications of this hybridization are so immense that it is difficult to miss the connections in the use of new media technologies. The rules of engagement that permit contemporary civilised peoples to argue that life can exist in non-carbon based material or that cyber bodies will become the preferred modes of future



existence future must also permit humans, spirits and gods to interact with each other in indigenous belief systems. These different belief systems share a common view of the phenomenal world as a self-sustaining system in which all life forms strive for the right to exist, albeit within different dimensionalities. Thus, the price we pay for the right to exist is an exchange of perceptual awareness that sustains the very system that supports all types of bodies, be they located in ancestral planes, cyberspace or in everyday reality. This is not such a difficult stretch of the imagination if we compare the astronomical time it took for human beings to develop from *Australopithecus* 5.5 million years ago<sup>6</sup> to *Homo sapiens* 35, 000 to 40,000 years BC to the “minimal” time it took us to travel from spirit possession to virtual existence in cyberspace. My point is that we have not progressed far enough to forget the mythical narratives that are deeply embedded in our genetic substrates. I argue that the memory of these “lived experiences” emerge not only in our theoretical constructions of the “other” but also in our contemporary performance rituals. To assume that we have left these states behind is to live in a dislocated body.

Andy and Larry Wachowski’s film triad of *The Matrix* (1999), *The Matrix Reloaded* (2003) and *The Matrix Revolutions* (2003) explores some of these same themes. These films propose that the “real” world is a vision created by an omniscient “other” or “others” whose existence depends on ours just as ours depends on theirs. Such beliefs are also at the root of Western culture through early Greek philosophical thinking and practice. According to Kahn (2001: 139), the Pythagorean tradition fed modern thought through three distinct strands. The first is through the occult and the supernatural, the second through transmigration and vegetarianism and the third through the mathematical and musical traditions. Thus, philosophy, biology, mathematics and music provided early on fertile soil for such practices and beliefs to grow. Through them, we see a particular relationship of the visible to the invisible, the material to the immaterial, and the human to the divine, ideas now redefined in the context of technology. My point is not that we need to revert to earlier incarnations of these ideas but to recognize their genealogy and to remap or transform them.

#### **4.4 New Diasporic Bodies**

Columbus reportedly discovered the New World, to which Africans were brought, by chance, i.e., he meant to find a route to the riches of the Far East. The massive African

presence in the New World, therefore, resulted from a journey by one culture, the European, to get to another, the Far Eastern, through an alternative route. This journey led to the malicious long-term enslavement of the African and the decimation of many indigenous peoples. However, it also created a new “diasporic body”, one that combined the values of different cultures without denying the importance of any one of them. In fact, Gilroy makes this argument in *Against Race* (2002).

Brand (2001) argues that the enslavement of an entire race created a psychic shock so deep that it continues to haunt African diasporic peoples to this day. She represents this rift in consciousness as a door of no return. Brand claims that the cultural and political meanings inherent in the black body originate at this door and remain trapped there. At the same time, she argues that this door is an opening to a virtual world that is neither here nor there. If the body is the place of captivity and the door represents the place of dreams, then her call for a new conceptual schema for this “New World” reaches beyond the black body to other captive bodies. Brand wants us to believe that this door holds redemption because it exists as an absence, a place we do not know but should explore. The idea of being in the body, captive to its history, and being out of it, free to create a new cognitive schema, underpins my use of her text and my conceptualization of *Out-of-Body*.

The idea of being a captive of events that took place in the distant past is also a key issue in *Shango Meets Ogun*, a work I co-choreographed with Olugbenga Taiwo, a friend and colleague at King Alfred’s College in Winchester. *Shango Meets Ogun* details an encounter between two sets of identities: the first is the virtual meeting in Yorubaland of two *Orishas* from a distant past and the second is the meeting of two modern day performers. Shango the god of thunder and Ogun the god of Iron ritually meet to enact a painful reminder of their past and to consider how a new future might be shaped. Shango was a human being, the fourth King of the traditional Yoruba kingdom of Oyo, who became the god of thunder and lightning after his transformation to the divine status of *Orisha*. The deposed king hung himself in remorse for his earthly deeds, but the legend claims that his body was never found. His hubris was the abuse of power, but his ultimate sacrifice led to his divine transformation after death. *Ogun* was the god of Iron, who forged in his kiln tremendous weapons of war. In the Ifa creation myth, Ogun was an *Orisha* who came down to earth to help human beings, unlike Shango who made his way up to heaven



through sacrifice. Ogun's hubris comes out of his inability to balance his powers, while his tragedy emerges from his forgetfulness of the task he was sent to perform.

*Shango Meets Ogun* explores the potential embodied in these two archetypal figures and in the creation myth that Ifa represents. My main objective was to create a structured performance improvisation in which issues of deep personal and cultural significance could be shaped in a technologically interactive environment. I devised this interface to explore concepts of agency and uncertainty within a shared ancestry. Therefore, the choreographers posed some of the following questions: 1) How are the Orishas (Yoruba divinities; archetypes) perceived and/or expressed in the African Diaspora? 2) How do they renew themselves through the passage of time? 3) How are these myths relevant to diasporic Africans in the middle of a paradigmatic technological revolution, and 4) What are the consequences of shedding or forgetting these systems? These questions, I contend, find answer in the performance.

The shifts in the balance of power that occurs between the characters in the work typify the broader role of the Orishas in maintaining balance within the three-tiered African world-view. As emissaries of Olodumare (God), Shango and Ogun also represent nature's archetypal forces that govern the endeavours of humanity. These forces still exert a powerful cultural influence on peoples within the Yoruba theological and philosophical diaspora. The transformations that occur in *Shango Meets Ogun* may be metaphorical, but they are embodied metaphors, and as such are real. The interfaces and dimensionalities they address implicate the African in another metaphoric journey that Columbus initiated, one that travels westwards to discover the East. These directions also function as metaphors of transformation in which new identities are shaped through a journey in time and space. However, the ability to recognize which culture is being transformed, and by whom, should be important to us all.

#### **4.5 Crossing Bodied Cultures**

In my effort to link culturally diverse practices and to recognize the contributions of diasporic Africans to the development of Western knowledge (Gilroy, 1993), I will now show how the development of modern dance in Europe and North America reveals a range of cultural influences on its aesthetics, movement vocabularies and philosophical basis. This journey using historical time and cultural space has been

necessary to ensure that the appropriate connections are made. I am here referring to connections between different bodied cultures or the processes of embodiment of different cultures, to which the notion of abstraction, the resurgence of a different type of narrative and its connection to technology as a narrative of “lived” human efforts are complexly linked.

The new modern dance of the early 20th century was individualistic in expression, and although it often used cross-cultural and cross-disciplinary perspectives, it was not identified with these perspectives. Martha Graham incorporated Indian yoga practices into her modern dance technique. Rudolf Laban’s interest in Eastern mysticism and theosophy shaped his theoretical formulations and his dance legacy. Ruth St. Denis used cultural influences from both the Near and Far East as well as from the Native North American Indians. Josephine Baker, Pearl Primus and Katherine Dunham explored a wealth of material from West African and West Indian sources, material that found its way into mainstream American culture. Merce Cunningham and John Cage used conceptual ideas from Chinese Buddhism for their dance and music compositions; and the list goes on. All these activities reflected shifting trends in modernity, which sought to explore individual psychology as a new geographical and cultural space.

By the second decade of the 20th century, two main directions had begun to emerge; one was an expressivity driven by strong emotive power, and the other a more abstract form that seemed to shun obvious emotional displays and narratives. The two developed simultaneously, one in which association, identification and self-absorption were important and the other in which dissociation, non-identification and an emphasis away from oneself took precedence. Both would establish their own tradition. It is in the latter, more disassociative context that the radical post-modern style would emerge and, as I will argue, provide a fertile ground for experimentation with new technologies. However, before I do this, it is necessary to look at the differences between the Oriental and Occidental views of the world, and how these views affect our examination of interfaces between culture and technology.

In facing the East, metaphorically and culturally so to speak, one generally finds different attitudes to life. For example, Eastern philosophy proposes that everything is composed of the same materiality at a very fundamental level (Eliade, 1970). In the



yogic tradition of India, intellect is considered a material thing that issues from the same source as the natural world's physical objects, the two differing only in degrees of materiality and distance from an original source. This tradition sees biological and psychic activities as material aspects of the same phenomenon in which inner and outer worlds correspond (Eliade, 1970). Thus, evolution means something different to the Indian mind than it does to the European. In the philosophical thinking of Samkhya and Yoga, the basis of most yogic philosophy and practice in both East and West<sup>7</sup>, no new form can progress beyond the possibilities of existence present from the beginning of the universe. New species, as Western theories of evolution suggest, are therefore impossible (Eliade, 1970). Eliade argues that the generation of the physical world, according to these teachings, is a psychic act of self-knowledge. As such, objective and psychological phenomena form a common matrix in which every physical and mental phenomenon is a fragment of a great unity, each possessing a memory of its creative genesis. Hypothetically, the original creation can become known through a careful examination of a fragment of that whole. Both Western and Occidental thinking claim that the human being is a microcosmic fragment.

Since memory and perceptions allow us to create and recreate the physical world, the above argument explains practices that seek to reconstitute memory as an aspect of contemporary performance practices. The Indian philosophical tradition teaches detachment, the idea that our greatest human accomplishment is to stop the flow of acts that creates the material world. This teaching claims that when such detachment occurs, things collapse into an original point in space-time. Exchanging movement for stillness is, therefore, an important objective in Yogic meditation techniques, an activity designed for the practitioner to perceive the world in its "true" state.

Hindu philosophical teaching also claims that the phenomenal world issued from a single point in space-time and will return to it. It teaches that human beings should conceive of their actions as part of the objective to return. Following this thinking, we can argue that all human experience is a manifestation of the same creative embodying or destructive disembodying force that the Hindu and other ancient traditions have identified as the universe forever regenerating itself in an eternal dance. Eliade (1970) also argues that when human beings dance, they are reliving the creation of the material world through their psycho-mental creations. Thus, the analogy between an intentionality that sustains itself through creativity and destruction, and human beings

who display their creative and destructive processes through art is a deliberate one. The objective is to show that the two processes of creation and destruction radiate from the same source and in one way or another sustain that original source.

There is another teaching, introduced by P.D. Ouspensky (1983), which attempts to mediate occidental and oriental traditions. Ouspensky received this teaching from the Caucasian mystic Georges Ivanovich Gurdjieff (1877?–1949). Gurdjieff explains that everything feeds on, or is fed by, three different kinds of sustenance. The first is food and water, the second is air and the third is impressions. Although it is possible to live for weeks on water alone, we would be dead in minutes without air. However, without impressions we could not last a moment. The point is that impressions feed human awareness, and our existential lifeline to reality as well as the world of the imagination depends completely on them. There is much talk of the computer-human interface and of the implications of life in silicon bodies. I am of the opinion that a deeper exploration of these issues would reveal parallels with other forms of knowledge that could change the frame of reference we use in our practices and/or discourses.

In current dance productions that use computer-generated virtual, immersive, sensory and “intelligent” environments, the underlying idea is that the body interacts with, and is an integral part of, a living space. A device detects an object and the targeted object in turn defines the electronic device’s behaviour in the same way that the human body defines, and is equally defined by, other phenomena around it. However, the body has a more complex relationship to its bio-evolutionary environment than the computer. Conversely, one could also argue that technology helps us to be more aware of our “senses” in a desensitized world. What then, one may ask, are the fundamental objectives behind the use of technology by the performance artist? From this researcher’s perspective, the answer lies in facilitating processes of re-cognition through different notions of performance. This, I contend, is the new route that people in the Western world are beginning to recognize in their efforts to reconceptualize their existence within a broader phenomenal world. It is also one that has left traces in dance works of the past.

#### **4.6 Facing West**

We have seen that the dancing body is analogous to recreating the world as embodied consciousness in at least one Eastern teaching. Western society has a history of subtly



removing the body from the everyday sphere by institutionally ignoring and/or suppressing its desires. In 18th- and 19th-century Western Europe, the romantic ballet set the standard for courtly and aristocratic behaviour, and in doing so it also influenced both social and political policy. The juxtaposition of exotic dreaming with the harsh reality of the age conspired to produce work like *La Sylphide*, a ballet created by Filippo Taglioni (1777-1871) for his daughter Marie (1804-1884).<sup>8</sup> Filippo personally trained Marie in a new light fleet-footed style with springy elevation that Italian ballet master Enrico Cecchetti (1850-1928) would develop further a generation later. In the Romantic tradition, it was better to die for love than to live as reason's slave. It was also considered a supremely heroic act to succumb to one's passions as one struggled with them. Heroic figures received approval according to the worthiness of their tragic flaws. Such passion and imagination also exposed a desire for exotic far-off places and fantastic encounters.

*La Sylphide* reflects a state as near to virtual reality as one can get in the midst of the Industrial Revolution. Set in Scotland, considered by Europeans as a remote and exotic place, the ballet romanticized that country as a place that could only be reached through dream, fantasy and witchcraft. In such places strange creatures wait to play terrible tricks on unsuspecting humans (Au, 2002). It was irrelevant that Scotland was a real country with real people. In fact, this merely served to heighten its allure. Outside their immediate experience, people accepted anything, as long as it was presented to them in a believable manner.

Briefly, the story of *La Sylphide* is as follows: a winged spirit, or sylphide, falls in love with a young man who is betrothed to someone else. The sylph beguiles the groom-to-be with a kiss, and he falls passionately in love and decides to pursue her. A witch, Madge, casts a spell on a scarf that she allows the groom, a young man called James, to use to trap the sylph. As James captures the elusive creature with the scarf, her wings fall off and she immediately dies. He is overcome with grief at this trickery and dies at the hands of the witch, who appears not to have wanted him to marry the bride. The story ends with another young man, the favourite of the evil witch, marrying the rejected bride (Au, 2002). This is a very simple story, but strict moral imperatives or lessons awaited its audience.

The first lesson relates to the groom's weakness of mind. He is fickle because no logically minded person would pursue a sylph at such an important moment in his life. This weakness becomes the groom's undoing. This act of irresponsibility suggests not only a disregard for the sacred institution of marriage but also a disregard for society's rules governing individual freedom. Effie, the bride-to-be, refuses the attentions of her more stable admirer Gurn. The fact that Madge the witch senses that the spurned young man would make a more stable husband, even though Effie does not prefer him, makes her an anti-romantic, a despised character, a witch. With her power of foresight and her ability to punish, she arranges a tragic, but nevertheless romantic, end for James. Although James sacrifices his position in society through an irresponsible act, he achieves the romantic ideal because his ethereal love, not bound to the fleshly prison that is the human condition.

Another ideal is the true love and beauty of the luckless sylph and her pursuer James. The two are united in death but also in everlasting, disembodied and transcendent love. The corporate social body is then chastised for curtailing the transcendent reality of true love. The "message" in this ballet is complex, and the idea that society will allow people to experience the freedom of the theatre only to reinstate its rules reveals a complex self-nourishing entity. Society sympathizes with those who break the rules in the spirit of true love but is extremely strict about who wields the power to dispense justice. Before the French Revolution, this was the King's role. Half a century after one revolution and in the midst of another, artists sketched out this representation of a morality that society wanted to uphold in the face of a demoralized and war-torn Europe.

These imaginary worlds were important to people trying to maintain psychic balance. Theatres were "Dream factories" and "Fantasy machines" (Marek, 1965: 14) that allowed them to journey to exotic lands in the comfort of their theatre boxes. Indeed, the ability to conjure up dreams was an important facet of the ballet master's choreographic craft. In classical ballet, the dancers' bodies look ethereal, an appearance that belies the intense training of the women who dance these roles. The ballerina's movements seem effortless, but she has to make enormous sacrifices to achieve such ease. The stage itself was sacred; it belonged outside of time, yet existed in an eternal present that was out of the audience's grasp.



This ballet, and others, reveals a culture's need to create an illusion at a time when its physical reality is being destroyed by war. It also helps us to understand that these two bodies, societal and personal, are intimately bound together through processes of affirmation and denial. *La Sylphide* expressed a Romantic philosophy in which the ballerina represents a dream world, the unconscious, and her dancing body an aspect of the ethereal and virtual. Eighteenth and nineteenth century classical ballet thus embodied the techniques of the virtual even as a more rational world began to appear. Romanticism existed in the ballet vocabulary alongside and in spite of Newton's laws of gravity. While logic and certainty sought to replace the world of dreams, the romantic ballet subverted that aim. In short, mid-19th century society exhibited itself as a paradox, and *La Sylphide* reveals its illusory unity.

#### **4.7 Creativity and Embodiment: Structuring Performance**

Only when a certain level of persistence has been obtained within the rhythm, that is also to say, that a certain level of persistence has been obtained within the step, can spontaneous movement occur, modifying the original rhythmic structure, thus calling for a response. It is within this movement just described that the catalytic moment we call "improvisation" tends to arise within the rhythmic context...

At this stage, improvisation is no longer a simple technique or artistic device expressing the urge to "take risks".

Improvisation is at the very heart of the concept by which art and life fuse as a means to serve one and the same goal.

(Maboungou, 1997b: 50)

I began this chapter by saying that scholars are fond of characterizing dance an ephemeral art form, i.e., as not fixed in space and time as a painting or a novel is. I went on to argue that ephemerality is relative, as traces of a dance's presence are left everywhere, in bodies, in space and in other media involved in the event. I contextualized the relationship between memory as reality and fiction in several of my own works on the DVD "Choreographing Discourse", maintaining it was possible to remember or recognize a "history" of events, which are deeply embedded in memory and which tend to emerge only under certain conditions. Performance, as such, became a methodological approach in attempting to re-cognize or reconstruct memory, cultural or otherwise.

By replicating procedures in the creative process, I was able, through the data used to construct these performances, to draw a number of conclusions for myself as well as leave the way open for the audience to do the same. This process, I argue, is a

necessary condition when one invites an audience to view a work. It also fulfils other conditions for a theory that claims that, as human beings, we are distributed identities, and that the way to unity is to approach it from the position that there exists an interface through which paradox can be resolved. The machine-human interface, therefore, contextualizes the human condition from different perspectives. Our development and use of new technologies clarifies this position, in my view. Its problematization of what is human and what is machine has made us more aware of issues that are marginalized in society, the most important of which is corporeal centeredness or phenomenologically being in the body as a “lived” or remembered experience.

The process of “feeding” oneself with new impressions facilitates this remembering. The old media, i.e., sound as spoken language or music, visual images of the natural world and the ability to touch or sense people, beings and objects, all help to establish a connection to the world and to reinstate our sense of being embodied. Left solely to perceive things visually, we miss a great deal of what exists in this world.<sup>9</sup> The human eye cannot register visual impressions from images that occur in intervals less than 20 to 50 milliseconds.<sup>10</sup> The relation of an electron’s life to our perception is that if we were to see an electron as a flash in 1/10,000 second, we should not see the electron in the strict sense of the word but only the trace of the electron, consisting of seven million revolutions multiplied by thirty thousand, i.e., a spiral with a thirteen figure number of rings (Ouspensky, 1983: 336). This implies that if we rely on visual images for a final understanding of the world and of ourselves, that understanding would be very limited.

This research has suggested several strategies for recognizing and accessing the memory that is inherent in bodies. These strategies are contextualized in this chapter as choreographing discourse, characterized as a methodological approach in a practice-led research strategy. Thus, my approach to practice, i.e., choreography, follows my intentions as a creative artist, which are to make theatrically interesting work and to stimulate an audience to think and question by means of techniques that may or may not use a range of technologies and by means of contextualizing my work within a transdisciplinary perspective. In many of these pieces, my strategies include the manipulation and exploration of sound as language and music. Sound has been a special concern of mine, since its vibrations can resonate through material substrates to



reveal much information about their composition. Between breaths as a measure of life, sounds as a measure of time and impressions as a measure of awareness, we experience the world in unique ways. My point is that our understanding of the world can be enriched from the perspective of sound vibrations and their ability to affect bodies.

To illustrate my point, I would like to look at how the octave and the twelve-tone chromatic scale shape our cultural orientation to sound in Western music. This illustration also serves to further contextualize *Walk-About-Timeless* (see p. 56 of this document) as part of a development of certain practices I pursued throughout my career as a choreographer, practices that continued in another direction throughout the works on the DVD “Choreographing Discourse”. As I mentioned before, in Western music, the octave’s 2:1 ratio of vibrational frequencies establishes a deep psychological framework that conditions our cultural life (Lawlor, 1982, p. 82).

Lawlor argues that the experience of hearing the octave contains the simultaneity of sameness and difference, where the higher sound occurs twice as frequently as the lower. He echoes a fundamental tenet of the Pythagorean philosophical tradition, which claims that the octave contains a system of proportional relationships that can be used to describe any completed process. Physical as well as psychological events contains such processes. In other words, every completed event or phenomenon we experience has roughly the same internal structure mapped out by the octave.

The octave is like a circle: it returns to itself in space and time. The octave not only returns to itself but also resonates at a higher pitch; it leaves one environment or plane of events and enters another at a higher frequency. It is analogous to the quantum leap, where an electron can jump from one dimension to another when it reaches a certain threshold of intensity. Dreams operate under a similar principle. At the level of our waking much of the content of these dreams disappear, and we are left with some images and a feeling of what was experienced in the dream state. Thus, circle, octave, particle and human experience have orbits that refer to time as an eternally returning process, but to our perception this flow is interrupted because we cannot remember certain states or experiences.

Victor Zuckerkandl, in two volumes dedicated to exploring music and the tonal world in general, argues that the forces which act in the tonal world manifest themselves

*through* bodies but not *upon* them (Zuckermandl, 1973a: 365). Zuckermandl claims that this is an important distinction because the physical event becomes the conveyor of the action rather than the action itself. Motion along the scale is an “away from” that ends in a “toward”, the goal of which is an octave higher from the start (Zuckermandl, 1973a: 96–97). Tones, he argues

are not primarily something external related to some inner life; the relationship between external and internal is wholly embedded in the tone itself. The inner life which music reveals behind the external tones is the inner life of the tones themselves and not that of a psyche. (Zuckermandl, 1973a: 153–54)

This argument suggests that the body itself is a complex network of sound vibrations, which gives it its unique identity. Sound and movement are thus expressed analogously in the totality of the body. The fact that music, through particular harmonies, evokes emotional responses in the body corroborates this statement. If, as Zukerkandl argues, music reveals the inner life of the tones and not that of a psyche, then we must conclude that sound, instead of determining content, reveals sympathetic psychic structures in us. This is important as it allows viewers their unique perspective on the works that were specially made as part of this thesis.<sup>11</sup> It also supports my statement in the introduction to the thesis that these seven works do not explain theoretical positions or that the written thesis seeks to explain what the choreographic works mean. The two support and refer to each other’s existence, as the work of an artist/scholar should.

These performances help to correlate different aspects of a discourse through a process of mediation, known in mathematics as the binding of two extremes by a single mean term. This dynamic creates the Golden Proportion, a very important tool for representation in music, architecture, dance, language and thinking. Leonardo da Vinci’s famous illustration (MacCurdy, 1977) embodies the principles of the Golden Proportion in human beings as the perfect idea-form. It also exists as a balanced relationship between the perfect fourth and the perfect fifth in the octave. Mediation describes the process of how one divides into two to become three (Lawlor, 1982: 80–81),<sup>12</sup> and its appearance in the stories and myths of different cultures establishes its universal appeal. In the same way that we manipulate the structures of music according to the laws of harmony, it is theoretically possible to do the same in all



spheres of human activity. Indeed, Rudolf Laban (1966) used this idea in the formulation of his notion of choreology, or choreutics, the title of his book.

Finally, these principles are deeply embedded in the work of G.I. Gurdjieff (Gurdjieff, 1950), the Caucasian mystic who for decades influenced the work of many European, Asian and North American actors and theatre directors, including Peter Brook.

Gurdjieff identifies consciousness, intent and effort as a way of approaching the process of individuation within a theosophical framework. Hinton, Zuckerkandl and Gurdjieff make separate but similar arguments, albeit on different terms and from different perspectives. However, all of them draw on principles from the work of the Greek thinker Pythagoras.

#### **4.8 The Pythagorean Interface**

The basis of Pythagoras' philosophy was mathematics, not necessarily the solving of problems, most certainly not applied mathematics, but mathematical theories and their application to conduct and the interpretation of reality. (Kahn, 2001: 124)

Pythagoras is an enormously important figure in the history of Western philosophy and learning (Gorman, 1979). However, it is uncertain how much of what is written about him is true and how much is legend. Whatever the case, we know that he influenced generations of thinkers from his time up to the present day. Gorman claims that, although much of Pythagorean philosophy is mystical and intuitive rather than scientific, it is nevertheless built upon an extremely rational base. He seems convinced that Pythagorean rationalism presents some very strong arguments for its mystical conclusions without recourse to faith or credulousness, even though it is irrational or even suprarational in its insistence on the reality of the unseen.

In Pythagorean teachings, the unseen is reflected in his approach to music (the music of the spheres), to mathematics (the divinity of numbers) and to philosophical enquiry (the unified thinking that human beings represent a microcosm of the greater Soul of the larger Cosmos or macrocosm). This approach led Pythagoras to the conclusion that human beings could understand the workings of the Universe as well as aspire to divinity themselves. In fact, Pythagoreans believed that the divine was already present in people; all they had to do was recognize and cultivate its presence. That meant cultivating a way of life in which the practice of philosophy was extremely important. According to Kahn (2001), the tradition of Pythagoreanism can be traced through

antiquity down to the threshold of the modern age through three distinct strands. The first is through the tradition of the occult and the supernatural, the second through transmigration and vegetarianism, and the third through the mathematical and musical traditions. Through the ages profound changes, driven by science and technology, would undermine all three strands of thought but at the same time support some of their basic premises.

Pythagoras' reported skill as a musician, his ability as a teacher to inspire devotion in his followers, his acute intellect, as well as his deep mystical beliefs, made him a huge figure in the history of Western learning. His philosophy spoke of the highest human aspiration as striving for harmony with the Universe, whose rationality expressed itself as a network of relations between music, mathematics, and human and celestial bodies. Sound was pure mathematics, and a celestial body moved according to the latter's logic. A mortal person could attain immortality through recognizing or recollecting the memory of the soul as it expressed itself through these relationships. Kahn (2001: 4–5) claims that it is through Plato that Pythagoras' ideas on the structure of the "world soul" by musical ratios and the "world body" by elementary triangles emerged from antiquity. Further, he asserts that Plato's reinterpretation of Pythagoras' ideas on recollection and immortality were fundamental to the notion that human beings could cognitively grasp the eternal forms that were the natural world's building blocks. In short, the idea that thought gained material form through sound and that the eternal Soul, operating through thought, was the means through which human beings could attain immortality, was a direct result of Pythagorean influence.

This combination of Pythagorean and Platonic ideas formed the basis of post-Renaissance thinking such that early dance theorists, especially Rudolf von Laban, employed it in their attempts to establish a systemic approach to analysing and recreating the moving body in space and time. Laban's contribution to 20th-century dance lies in linking this philosophy to his own efforts to give dance a rational basis. Laban and others recognized a set of very important relations that existed between science, art and spirituality. The Pythagorean cosmic soul was mathematically constructed out of number theory, geometry and musical harmony, so much so that the material body was a focal point in a concept of unity. People believed that a close study of the human body and the planetary bodies would yield valuable information about the nature of human behaviour in relation to the physical universe. World



making began as the rational numbers were generated, so that the cosmos arose “from the One by breathing” (Kahn, 2001: 28–29). In the number system, ten represented everything and zero stood for nothing. The sun was the number one and through a series of eight steps that represented the octave, it gave rise to the major planets. The extent to which this idea still exists is reflected in the basics of Boolean Algebras, the formal “language” computers use today. In it the number one (1) represents the set of all objects being discussed and zero (0) the empty set.

The ancient Greeks also organized their society according to fundamental principles derived from these teachings, which would eventually provide a basis for much of Western culture. What was left of this influence by the late 19th century would undergo radical transformation at the beginning of the 20th, primarily through processes of modernity. Every aspect of contemporary human reality has in some way been affected by notions of modernity, with art, science and technology probably more so than others. Additionally, the most distinctive feature of this movement was its emphasis on the primacy of individual subjective experience. According to Ferguson (2000), modernity’s attention to this experience masked some important links with the pre-modern world. Some of these concealed links would begin to emerge as society moved toward technology as the most important tool in its representation of contemporary reality. Hence, my main objective in the next chapter will be to establish the idea that many of the performance practices that began to emerge at the beginning of the 20th century were attempts to explore an organic relationship to self within an increasingly technological society.

## Chapter V Modernity, the Body and Technology

### 5.1 Connecting Histories and Practices

The word “modernity” implies a condition of existing in the moment, and when that moment is gone, so too is the essence of the thing one tries to capture. Modernity represents a condition of change, a state of constant flux, of upheaval and revolution. Defined temporally, it is an event in historical time, but it is also a state of newness defined by a particular aesthetic. One can also see it as a process of development or maturation. For example, 21st-century artists can be Modernists, in that they work with certain styles that characterized the 20th-century movement we refer to as aesthetic Modernism. The Modernist movement that emerged at the end of the 19th century and matured in the first half of the 20th century advocated radical change but at the same time rejected it. It embraced the tool for change, i.e., technology, at the same time rejecting it as dehumanizing. Modernity used the aesthetic of Modernism to introduce new values and realities, which were essentially different from those of previous eras.

Charles Baudelaire (1821–1867) described modernity simply as the newness of the present (Baudelaire, 1964). This newness, he claimed, had an element that distinguished the ancient from the modern in art because it concentrated on originality in the presentation of traditional material. Friedrich Nietzsche (1844–1900) described modernity as a recurring process that was always the same (Gogrof-Voorhees, 1999). Nietzsche argued that there was nothing new about specific phenomena since they all reproduced or repackaged the same old patterns. Early 20th-century society claimed to embrace newness but in fact desperately held on to its old ideals. The *avant-garde* movement that emerged at the beginning of the 20th century was a revolutionary one, with modernism contributing to the evolution of artistic forms the former provoked.

Early modern dance emerged out of this conflagration of interests. However, significant differences set it apart from all of the other more established art forms. To begin with, it had no tradition to speak of, at least not any coherent one. It rejected the institution of the romantic ballet, a form with deep social, political and aesthetic links to the court and the aristocracy. It also problematized notions of modernity and of



aesthetic Modernism, resulting in the evolution of a significant number of individual dance vocabularies, styles and movement aesthetics. If modernity finds its clearest definition in an exploration of subjectivity (Ferguson, 2000), then its close links with modern dance identifies the latter as a search for individuation through the reintegration of the corporeal.

In relation to dance, the most important aspect of modernity was a willingness to take risks based on strong personal conviction. A feeling also existed that human beings were creative partners with the Being or Force responsible for the existence of the phenomenal world. This concept of a partnership in creativity had aesthetic, ideological and ethical implications for society through its emphasis on immediacy, living life “in the moment”, and its emphasis on people taking charge of their own lives. Modernity proposed that society take charge of its evolutionary purpose (Horn, 1994). Through its individual members, society began to examine itself in some of the new and interesting ways that follow:

1. A commitment to the formal exploration of how we see the world rather than what we see in it.
  2. A new faith in quasi-scientific modes of conceptualization and organization that reflects the rationalist, progressive nature of society.
  3. An ideologically inspired use of fragmented forms, which reflect the break-up of former systems of thought and belief.
  4. An aesthetic self-reflexivity, where artefacts explore their own constitution, construction and shape.
  5. A clear demarcation between popular and elite forms of culture.
  6. A gradual growth of interest in non-western forms of culture.
- (Woods, 1999: 8–9)

These six characteristics clearly pose a radical challenge to the continued viability of existing knowledge. Modernity represented a never-ending quest to remain current, to rewrite the past and to create a new future in the moment, a moment that nevertheless tried to capture and redefine all previous histories. Historically, it was a slow conceptual shift that accelerated rapidly at the beginning of the 20th century, redefining notions of space, materiality, physicality and temporality, and creating room for the virtual as a scientific rather than a spiritual concept. This research proceeds to examine the work of four individuals and the movements they founded or sustained as examples of modernity’s close association with the technologization of society.

Using contrasting methods to present the body as the subject of art and new performance practices, F.T. Marinetti, Vsevolod Meyerhold, Rudolf Laban and Oskar

Schlemmer demonstrated one or more of the principles outlined above. Their contributions to modernity link to five main themes: 1) industrialization and modern city life, 2) dynamism, simultaneity and interpenetration, 3) mechanical art, 4) the theory of the body, the marionette and the automaton, and 5) dance. I will address these points in detail under the sections devoted to each of these four men. The main objective in doing so is to support the argument that 20th-century art practices indicate a preoccupation with performance as an attempt to establish an organic relationship to self within an increasingly technological society.

## **5.2 Marinetti and the Futurists**

Two movements had a profound influence on 20th-century perspectives on art, culture and life in general. The first, Cubism, was individualistic and contemplative in nature, while the second, Futurism, was socially and politically aggressive (Hultén, 1986). Both were fascinated with the dynamics of energy and movement in contemporary society, and together they would significantly change the way people perceived themselves as part of the world around them. Some Futurists exploited the contemporary studies of human movement conducted by Etienne-Jules Marey in Paris and Eadweard Muybridge in California, a fact of great significance in that both were exploring new technologies as key to creating art. The Industrial Revolution, glorified for its progress through the machine but also blamed for turning people into automatons, influenced this simultaneous development of technology and an interest in the body's movement behaviour.

Big city life had a dynamism that was both exciting and threatening. Cubist expressive space captured this complexity as subtle, clinical, subjective and introverted art. Futurist expressive space, on the other hand, was loud, dynamic, aggressive, uneasy and often violent. Cubism was native to France, its capital city full of elegance and sophistication, the centre of contemporary culture at the time. Futurism was born in Italy with its vast tradition of art and culture but whose stagnant administrative institutions nevertheless kept it on the periphery of contemporary art and culture. The aim of the Futurists was simple, namely, to return Italy to the forefront of contemporary artistic and cultural activity.

Catapulted into international prominence with a combination of original ideas, aggressive style and substantial financing from Marinetti himself, the Futurist



movement gained the attention and sometimes the respect of contemporaries. Marinetti launched the movement from Paris on 20 February 1909. His publishing of the “Founding and Manifesto of Futurism” in the daily newspaper *Le Figaro* was one of a series of performance acts that was to establish his own reputation and that of Futurism as one of the most notorious and controversial Modernist movements. At that point the group consisted predominantly of young male artists: Umberto Boccioni, Carlo Carrà and Luigi Russolo, joined later by Giacomo Balla, and Gino Severini as a corresponding member. A tremendously creative, aggressive, provocative, political, propagandist and disruptive energy characterized their work. Truly avant-garde in concept and execution, Futurism was the first attempt to reorganize art and society around technology and the machine ethic, thereby anticipating the late 20th-century’s digital revolution.

Marinetti was convinced that technology was the means through which the new society of the future could be understood. Italy needed something to drag itself out of its “deep, self-induced sleep”, and he felt that the speed, power and energy of the technological medium made it an extremely attractive prospect for a nation on the brink of a new self-discovery. The machine symbolised progress and an awakening to the future. Body and machine would enhance each other to produce a new aesthetic. Marinetti clearly wished his movement to be remembered as the major force responsible for changing the course of Italian social, cultural and political life. In typical high-blown style, his manifesto announced an intention of ending to what he termed a narcissistic and contemplative kind of art (Apollonio, 1973). Marinetti argued that the artist’s duty was to use art for radical political action. Through a novel expressive treatment of mechanization, this new art would lead toward progress, establishing technological development as the valid concern of art.

In implementing these objectives, the Futurists introduced a concept of performance action on the theatrical stage that was not remote from the complexities of everyday life. Although Marinetti himself had little or no experience of dance, he ventured into this area by writing an extremely critical review of Isadora Duncan’s work in his 1917 *Manifesto of the Futurist Dance*. My choreographic work *Futurist Equation* takes as its title Marinetti’s equation at the start of his manifesto. However, the work itself is a performance debate using dance that plays on all the definitions of modernity outlined at the beginning of this chapter. These definitions of modernity are as follows: a

condition of change, a state of constant upheaval and revolution, a process of development or maturation, and, finally, a process the individual artist goes through to develop an artistic style. In an attempt to define the notion of the future for those of us who have inherited these ideas, I used this “equation” because it draws on themes, ranging from Fascist politics to contemporary feminist debates, and issues of cultural exclusion. Thus, the photos of the performers as children projected onto the set and the disembodied presence of other participants through recorded text turn the performers and participants into inheritors of a body of knowledge that they are obliged to confront.

In the *Manifesto of the Futurist Dance*, Marinetti argues that Duncan never managed to project anything but “the most complex feelings of desperate nostalgia, of spasmodic sensuality and cheerfulness, childishly feminine” (Marinetti, 1917). Even though he encourages the Futurist dancer Valentine de Saint Point,<sup>1</sup> he is equally critical of her. Marinetti encouraged Giannina Censi, another Futurist dancer, to interpret his *Dance of the Aviatrix* (1917), which in various forms she toured through Italy in the early 1930s. The charges of misogyny and/or macho ideology levelled against Marinetti by feminist writers are not baseless. The “Feminist Manifesto” (1918) of avant-garde poet and artist Mina Loy, a.k.a. Mina Gertrude Lowy, can be seen as a feminist response to Marinetti’s 1917 *Manifesto of the Futurist Dance*. Loy advises women to look to themselves to discover who they are rather than seek recognition from men trapped in rigid definitions of gender roles (Loy, 1982). Although Loy was briefly involved with the Futurist movement,<sup>2</sup> she had little sympathy for Marinetti’s attitude to women; her poems transform the Futurist idea of the dynamic mechanized body into a symbol of female creativity (Loy, 1982).

Marinetti’s attempts to promote art as a source of energy that could affect the management of civil affairs (Apollonio, 1973) has been characterized as a double standard. In the eyes of feminists like Loy, the Futurist agenda for a total transformation of the body politic was doomed to fail. If the Futurist’s visionary enthusiasm sensed that the new art should evolve hand in hand with science and become a branch of knowledge for all mankind (Apollonio, 1973), it excluded the efforts of women to present their own bodies irrespective of male approval or consent. It could be said, however, that Marinetti and many of the Futurists were equally



disdainful of other artists, regardless of their gender, and that every single Futurist Manifesto was imbued with the same aggressive, intimidating and declamatory style.

In his *Manifesto of the Futurist Dance*, Marinetti states that European dance in the first decades of the 20th century was nothing more than a pale spirit of the Italian ballet turned into an erotic anachronism for foreigners on the stages of Parisian theatres. Although hopelessly chauvinist, his comments on Duncan were in some ways insightful: her feelings were indeed complex, much more than her choreography depicted. One can always argue that the expressive vocabulary of the dance then was simple and immediate. However, to compliment Nijinsky's dance as pure geometry and to criticize Valentine de Saint-Point's *Métachorie* as passéist poetry navigating old Greek and medieval sensibilities (Apollonio, 1973: 145–46) is to play a cruel hand of gender politics. The hard, brittle, masculine energy that characterized Futurist style and aesthetic seems quite strange for a woman to adopt, but Saint-Point maintained her own voice and style, even though she would later abandon Futurism altogether in 1914, before the end of the movement's first stage.

In her *Manifesto of the Futurist Woman* (1912), Saint-Point set out her theory on the dynamic potential of war and art as the height of sensual experience. Her *Manifesto of Lust* (1913) deals with the sensuality of the woman as super female. Her views on women contradicted Marinetti's, but it is perhaps a testament to her spirit of revolution that she was accepted as part of the Futurist cause. Indeed, hers was a very visible presence. *Métachorie* was an abstract combination of geometric, mechanical movements performed to love poems and hate poems recited in front of projections on her stage fabric of calculus equations and rotating coloured lights. The combination of poetry and technology invoked themes in Isadora Duncan's and Loie Fuller's works. Saint-Point used the Futurist platform to promote the freedom and independence of women to love and hate publicly, and to be a part of the male-dominated domain of science, industry and technology. However, feminist platform did not substantially change the ideology of Futurism in all of the Manifestos published by the men, which denigrated old-fashioned women in favour of a new concept of the Futurist woman and presented the Romantic notion of femininity as anti-modern, weak and *passéist* (Apollonio, 1973).

Umbro Apollonio (1911- ), a curator interested in modern art, helped to reintroduce Futurism to post-war audiences and claimed that Futurism could not be evaluated according to the usual norms of art criticism. He argued that Futurist art was simultaneously art and non-art, its aim being not so much to become art as to comment on the state of art and to predict its future role (Apollonio, 1973:16). He was critical of the movement and careful not to valorise its members' achievements. Futurism foresaw the concept of a popular culture and used the popular media to appeal to contemporary audiences. The Futurists pursued their aims for a free and progressive society with an arrogant, imperialist, and autocratic style, glorifying the machine-human interface by creating art with bicycles, motorcars, aeroplanes and machine guns. Theirs was an art amplified in contemporary performances through technological devices like robotic instruments and other intelligent machines.

Not surprisingly the Futurists declared in a 1914 Manifesto, *Weights, Measures and Prices of Artistic Genius, Futurist Manifesto of 1914*, that no essential differences exist between a human brain and a machine (Apollonio, 1973). It is an argument that continues to this very day with substantially more scientific proof behind it. In the founding manifesto, Marinetti betrays a childlike enthusiasm of someone freed from a great burden, emerging into a world simultaneously fascinating and terrifying.

'Let's go!' I said. 'Friends, away! Let's go! Mythology and the Mystic Ideal are defeated at last. We're about to see the Centaur's birth, and soon after, the first flight of Angels! [...] We must shake the gates of life, test the bolts and hinges. Let's go!  
"The Founding and Manifesto of Futurism" (Apollonio, 1909: 20)

All causes need martyrs, and Umberto Boccioni (1882–1916), the most promising of the Futurist artists, fulfilled that purpose by falling off his horse as an army conscript during the First World War. The effects of Boccioni's death are difficult to calculate. He was certainly one of the bright stars of the movement, a youthful talent whose paintings and sculptures exhibited the dynamics of form associated with early Futurism<sup>3</sup> and themes important in Modernism, i.e., industrialization and modern city life, dynamism, simultaneity and interpenetration, and energetic movement. His *The City Rises* (1910) celebrates industrial Milan with its smoking chimneys. In this painting, street workers attempt to control huge draught-horses in a setting that includes a streetcar, a locomotive and building scaffolding. Bodies in action,



horsepower and industrial power are conveyed through light, form, colour and dynamic energy. Primitive urges, essential to the Futurist ideology, pervade Boccioni's work.

The same primitive urges are evident in Marinetti's "Dance of the Shrapnel" in *The Manifesto of Futurist Dance*. The body movements for this piece are static, but the energy conveyed is violently dynamic. Compare movements three and four below.

*Movement 3:* With the hands (wearing very long silver thimbles) raised and open, as high as possible, give the proud, blessed, silvery explosion of the shrapnel in its *paaaak*. The danseuse will hold up a sign printed in blue: *Long to the left*. Then she will hold up printed in silver: *Don't slip on the ice. Synovitis*.

*Movement 4:* With the whole body vibrating, the hips weaving, and the arms making swimming motions, give the waves and flux and reflux and concentric or eccentric motions of echoes in ravines, in open fields and up the slopes of mountains. The danseuse will hold up a sign painted in black: *Water duty*; another in black: *Mess duty*; still another in black: *The mules, the mail*. (Marinetti, 1991: 147)

Clearly, there is little concern for a pleasing aesthetic movement vocabulary here. In fact, the aim is to represent the scene as crudely as possible, in line with the desire to articulate a revolutionary politics. Yet there is sensuality in this violent carnage, a physicality that contradicts itself through the rich and expressive use of language, at one moment humanly "vibrating", "weaving" and at another giving machine-like instructions. The picture of the danseuse with a placard belongs to avant-garde theatre and to 1960s "post-modern" American dance rather than to the dance aesthetic of 1917 when this manifesto was first published.

Futurism also celebrated spirituality in art. Boccioni's notion of "physical transcendentalism" refers to an object's different mysterious and spiritual aspects. Bragaglia argued for the "transcendental nature of the phenomenon of movement" in *Futurist Photodynamism* (1911). In *The Exhibitors to the Public* (1912) Boccioni and fellow signers Carrà, Russolo, Balla and Severini speak of the simultaneity of states of mind in the work of art. My point is that such ideas lend themselves readily to a perception of the body and of embodied movement as beyond the realm of the visible but completely recognizable through their energetic configurations.

Marinetti and his colleagues wrote about, and actively engaged in, all aspects of art and culture from the sublime to the profane: they wrote on religion and spirituality,

cooking, architecture, ballet, modern dance, aeronautics, cinema, typography, music, poetry, sculpture, stage design, fashion and photography. They applied a variety of methods and often divergent approaches to each of their activities, all the time believing that technology led to the future and that the individual body as well as the body politic had to undergo a synthesis or mediation by means of technology.

The notion of the “primitive” in art that appeared in both Cubist and Futurist work relates to what some of these artists saw in African art (Andrea, 1995). A case in point is Picasso’s *Les Femmes d’Alger (O. J. R. M.)* (1907), women painted with an African influenced aesthetic. X-Rays done on these paintings at New York’s Museum of Modern Art (MoMA) reveal an interesting process that refocuses the notions of modernity and progress.<sup>4</sup> If the purpose of Futurist art was to transform society, then an important part of that transformation, namely, the linking of different ideas about the relationship between mythic space, technological space and bodily space, has not been adequately explored. Futurism threw the inherited 19th-century aesthetic in art and culture into total disarray in more ways than has been acknowledged.

### **5.3 Meyerhold, Constructivism and Biomechanics**

Like Marinetti, Meyerhold (1874–1940) had his own ideas of how to transform society through art. His goal was to introduce new and more modern ideas to the Russian theatre, not necessarily to bring it in line with contemporary thinking, but to make it more relevant to the needs of a developing Russian society. Lenin’s aim to establish Russia as an industrialized society supported the growth of Constructivism. This movement promoted progress, and artists were used as propaganda tools to uphold the ideas of the Revolution. This support by artists would end with the rise of Stalin, who distrusted art, especially if it revealed influences from outside Russia. Thus, it was through Constructivism that Russia responded to many of the objectives of Futurism.

Constructivist art was in many respects defined by utilitarian aims, i.e., logical thinking, mathematical analyses, and engineering principles to build a system ordinary people could enjoy. There was logic to Constructivist endeavours even though it sometimes appeared chaotic. One of its founders, Vladimir Tatlin, was influenced by Cubist and Futurist principles. Constructivist art incorporated technological ideas and the use of “architectonics”, or three-dimensional extrapolations of ideas, that the artist Kazimir Malevich first explored in his paintings. Meyerhold was a catalyst in



revolutionizing Russian theatre and helped incorporate the Constructivist aesthetic into it. His was a theatre of the avant-garde during the period after the Bolshevik revolution. Two of his associates, Liubov Popova and Varvara Stepanova, played a large role in this development through their design work for two significant productions. *The Magnanimous Cuckold* (1921) and *The Death of Tarelkin* (1922) became milestones in Russian Constructivist theatre.

These two productions displayed the characteristic formalized Constructivist design of bare settings, curtainless stage and no painted scenery. This fitted Meyerhold's policy of reducing the actors' contribution as individuals to a minimum in the interests of the play's overall design and intention. In addition, the use of geometric designs and modern industrial materials that Constructivists used to portray an unstable and disorderly society tended to stress utility over beauty and political message over superfluous aesthetic. Meyerhold's tendency to hide the actor's identity by the biomechanically trained apparatus of the body and by functionalist overalls allowed both Popova and Stepanova to design a utilitarian space in which illusion, emotion and ornament were kept out in favour of rhythmically organized movement as an integral part of the dramatic action.

Meyerhold's contribution to the modern theatre was based on his belief that the naturalistic style of Stanislavsky's Moscow Art Theatre was incapable of producing the theatre and the actor of the future. At first, he greatly favoured the Symbolist style, which went against the popular taste of late 19th- and early 20th-century Russian theatre. The new ideas he encouraged included innovations to the scenic space, stylized or choreographed movement and gesture, attention to musicality and rhythm in the actors and in the play as a whole and, more importantly, a training method for the right type of actor who could represent these ideas. Meyerhold insisted on closer contact between audiences and actors, and required that spectators use their imagination to become creators together with the author, the director and the actor.

Braun (1995: 48) claims that Meyerhold's idea of the stage of the future was most likely influenced by directors Georg Fuchs, Otodziro Kawakami and the latter's actress wife Sada Yacco. Japanese Kabuki Theatre featuring the latter two toured Russian theatres in 1902, and Meyerhold was reportedly impressed by the modernized version of Kabuki they called "Soshi Shibai". Theirs was apparently a very elaborate

and precise style. Fuchs's Munich Art Theatre explored some of the principles of rhythmic motion in Japanese theatre (Fuchs, 1905). Meyerhold may have drawn some of the same ideas from the same sources as Fuchs. With the experiences he acquired working at the St. Petersburg Opera, where dancers appeared regularly in the productions, Meyerhold would have felt very confident in teaching movement for the theatre. He felt that dance was to the body what music was to thought, i.e., a "form artificially yet instinctively created" (Braun, 1995: 87). He would later design a system for the teaching of his method called biomechanics: Like many contemporary choreographers, Meyerhold directed his actors to follow the rhythm of the music without duplicating its structures. He was in effect proposing, in the way he staged his plays, a phenomenological solution to the problem of the audience's ability to apprehend a level of intention through the body's actions.

Meyerhold envisioned a comprehensive, cohesive and modernized theatre based on the overall rhythm of its parts, largely determined by the actor negotiating the play or music script in a physically embodied manner. In his vision for this new *mise en scène*, he was also influenced by the work of Adolphe Appia, the Swiss theatre designer who worked with him at the Theatre-Studio in Moscow. Meyerhold consistently sought to organize his work so that speech rhythms, pauses, gestures and movements worked in harmony with the music and the spatial configurations of the stage, thereby orchestrating and choreographing time in a rhythmic and dynamic way. Stimulated by success and the tensions that led to the outbreak of the First World War, Meyerhold concentrated on using the theatre as a reforming influence in society. His staging of Vladimir Mayakovsky's Futurist influenced play *Mystery-Bouffe* in 1918 eerily echoes some of Marinetti's bold and aggressive performance tactics. Meyerhold's Bolshevik sympathies, openly displayed during the Revolution, became increasingly evident in the plays he staged. The controversial production launched a new dramatic style of theatre that quickly took root in revolutionary Russia and would eventually lead to Meyerhold's arrest, imprisonment and near execution. Subsequently, a ruthless and politically aggressive side of his character emerged. Many of his performances descended into rough assemblies during which revolutionary pamphlets and leaflets were distributed and funeral marches sung. This aggressive performance style soon attracted the scepticism of the Communist Party, which became increasingly



dissatisfied with the noisy public debates masquerading as theatre. Meyerhold was eventually forced to resign over the new policies introduced by Lenin.

As early as 1921, Meyerhold made plans to open a technical school that would offer actors a highly methodical course of studies. These would include singing, voice, dance, fencing, boxing, acrobatics and gymnastics, as well as general cultural and technological topics. His biomechanics, described as “the theatrical equivalent of [an] industrial time-and-motion study” (Braun, 1995: 172), was a compulsory daily class intended as a training method for stage actors. Meyerhold spoke of biomechanics, an important element of Constructivist theatre, in a manner that is strikingly similar to Marinetti’s rhetoric. The actor of the future had to relate his technique to the industrial situation, working in a society in which labour was regarded as a joy rather than a curse. He also spoke of the actor’s art as the manifestation of a force subject to the laws of mechanics. One could interpret this view as a clear response to the call of the machine age in an emerging industrial society. Meyerhold’s vision of administering to an ailing body politic through politically motivated performance actions was a characteristic Modernist trait.

The insights that had served Meyerhold as an actor and director, i.e., the mechanics of the circus, the mime and gesture of the *commedia dell’ arte*, the Russian Ballet, the forms of Oriental theatre, gymnastics, organized stage combat and a range of other physical techniques, were built into his system of biomechanics. In his own words, “biomechanics was designed to foster in the actor a sense of complete self-awareness and self-control in the performance” (Braun, 1995: 155). This statement was clearly in line with Meyerhold’s belief that one could experience an event profoundly through working from externals. He was to claim that this practice led to, and helped solve, “the most complex questions of acting technique, problems concerning the co-ordination of movement, words, the capacity to control one’s emotions, and one’s excitability in performance” (Braun, 1995: 177).

Movement principles developed by the American Frederick Taylor that optimized workplace productivity also very much influenced Meyerhold’s work. Taylor’s system followed three basic premises. The first was that existing production machines were inefficient, the second was that this inefficiency was due to a lack of proper management, and the third was that proper management entailed specific laws, rules

and principles applicable to all forms of human activity (Taylor, 1911). Taylorism, as it became known, claimed to be a “science” of effective management that established specific rules of motion, standard workplace tools and working conditions that guaranteed increased efficiency. Meyerhold experimented with Taylor’s principles in his staging of *The Magnanimous Cuckold*, among other productions, making it clear in a number of references to Taylor and the latter’s Russian disciple Aleksei Gastev<sup>5</sup> where the influence came from. Taylorism was part of a Modernist investigatory trend to maximise the output of human beings working in industrial production lines where they were often little more than machines. In societies that urgently desired to increase industrial productivity, it became clear that new methods were needed. Rudolf von Laban would also follow this line of investigation in Britain during the war. His collaboration with F.C. Lawrence produced the Laban-Lawrence Industrial Rhythm, which was applied to the selection, training and investigation of work processes to maximise efficiency in British factories during the Second World War (Laban & Lawrence, 1947, Kirtley, 2000).<sup>6</sup> This notion of optimizing efficiency in the performance of industrial tasks would link the use of technology in two quite different notions of performance. Later on in the century, when more sophisticated technologies appeared, a variety of new practices would emerge, further strengthening a link that von Neumann had sought to achieve, namely, bringing the task of logical mechanical operations into a narrative of human effort.

#### **5.4 Laban and the New German Dance**

At the turn of the 20th century, Germany was about to enter one of the most complex periods of its history. From about 1910 until the Second World War, different manifestations of *Körperkultur*, i.e., body culture, would dominate the perception of the Modernist body in that country. This “culture of the body” was activity formulated and disseminated not just by native Germans but also by many non-Germans who lived and worked there. It seemed that this country, especially curious about zones of experience that were “between worlds”, more than any other European nation, was determined “to integrate body consciousness into a larger cultural framework” (Toepfer, 1997: 20-21).

The German body culture was a mode of aesthetic performance that collapsed conventional distinctions between mind and body, subject and object, and self and



world through its two large categories of performance: namely, nudity and physical movement. Toepfer proposes that these two forms of expression responded to a range of questions, including how modernity could construct a new relationship between the body and the metaphysical dimensions of identity. Implicit in this was another question: how the body could fulfil its role as part of the modern industrial machine and at the same time become an agent of aesthetic expression. Toepfer argues that this dilemma helped frame the complex phenomenon of German body culture. This complexity was attributed partly to the unique historical conditions of modernity in that country, which focused perceptions on the body as a source of meaning that had previously remained hidden, masked by Germany's vast intellectual tradition.

One must remember that the particular German notion of body culture at the time encompassed a range of activities that included the performing arts, sports, fine arts, architecture, medicine, fashion, leisure, sex, labour, music, military discipline, ergonomics, theosophy and existentialism, as well as yoga and Eastern philosophy and mysticism. The body could be an efficient instrument of labour and at the same time project an ambiguous historical function that served to destabilize the viewer's perception. It is within this complex manifestation of *Körperkultur* that Laban attempted to develop a comprehensive notion of dance as an art form, something that he felt could express the human being's physical, emotional, mental and psychic potential.

Born in Bratislava, the modern Slovak Republic, Rudolf Laban (1879–1958), dance educator and movement theorist, had an interesting upbringing. He was the son of a military governor of Bosnia-Herzegovina during the late Austro-Hungarian Empire and travelled widely with his father. He was exposed to a diversity of cultural influences in these regions, influences that were to instil a lasting fascination with people's movement behaviour (Preston-Dunlop, 1998). After attempting military cadet school in Austria to satisfy his family's wish, he became a painter, finally settling on dance. He would spend the rest of his life choreographing, teaching, creating, organizing, promoting, documenting and analyzing expressive movement.

Laban worked in the climate of extreme political, social and aesthetic change that characterized the first decades of the 20th century. Around him were painters, architects, literary and theatre people, dancers and choreographers, all making

innovations in their individual fields. One such person was the painter Hermann Obrist, who played a crucial role in the development of early modern art in Germany. Obrist encouraged Laban early in the latter's career. So too would Émile Jaques-Dalcroze and Rudolf and Marie Steiner, whose work in organizing new techniques to study dance through music and rhythmic formation he knew of, and shared intimate knowledge of, through his mistress Suzanne Perrottet. Wassily Kandinsky, who had his Phalanx school close to Laban's in Munich and whose ideas Laban shared, was also an influence. Kandinsky believed in the expressive powers of colour and form in painting, and wrote and spoke openly about the notion of the spiritual in art (Kandinsky, 1947).

Laban saw Isadora Duncan dance in Zurich but was reportedly not impressed, claiming that she did not set out a formative method that went beyond her individual expressive talent (Preston-Dunlop, 1998). He also came into contact and worked closely with Tristan Tzara, Hugo Ball, Emmy Hennings and other Dadaists through his students. Laban's dancers apparently choreographed and performed with the Dadaists at the restaurant/bar/theatre Café Voltaire in Zurich. Mary Wigman, his great protégé in the development of German New Dance, always extremely close to his work until she formed her own group and school in Dresden, was also there. Preston-Dunlop (1998: 56) claims that although there was a great contrast between the aims, processes and products of Laban, Wigman and Tzara, they were all "vigorously denying the old" and attempting to shift society's values in a radical manner.

Laban was radical in the sense that he denied the old and made enormous efforts to change it during his lifetime. His attempts to influence body culture in Germany and to promote dance as an independent art form continued until the Nazis threatened his life. From nudist camps to gymnastic halls, and from opera houses to large open-air sites where his *Bewegungschor* (movement choir) participated, Laban was continually at the forefront of this *Körperkultur*. He was an example of the new "modern identity", which often displayed contradictory impulses, desires and ambitions (Toepfer, 1997).

Although Laban epitomised a certain cultural *Zeitgeist*, through his many summer workshops in Munich and Ascona, through dance schools he formed in different European cities and through companies he directed at the city theatres in Stuttgart, Mannheim, Hamburg and Berlin, he was unable to connect to a broad German



audience through a physical presence as Wigman did. Wigman had an intensity that captured the German audience as only she could (Manning, 1993). Laban's main contribution came from a desire to give dance its own organization, its own ideological space, and its own theoretical and analytic frameworks. He felt that dance had to be free from the constraints of music, follow its own inner paths, be free of language but be a language unto itself, and express the individual's inner spiritual, mental and emotional life through the physical body. In short, he sought its establishment as an art form in its own right along with the other arts. In this, both he and Wigman would promote the notion of absolute dance, i.e. dance that could speak through movement alone.

Laban was part of a comprehensive movement of cultural change grounded in a holistic view of the body. This attempt to establish a particular ideology and an aesthetic of movement that embraced everyday life, able to capture the *Geist* or spirit of a people, would eventually lead him into conflict with the politics of National Socialism. As Germany struggled to stabilize its financial affairs between 1919 and 1921, what was before an avant-garde entered the mainstream after 1922. Its culture of the body wavered between two poles, one organic and the other mechanical. In the period between the World Wars, and especially in the late 1920s, a strong climate of conservatism gripped the state's institutions. This bred a strong desire for individual freedom of physical expression. Laban's efforts to introduce his work within the State-run dance institutions were at first welcomed, then met with scepticism and resistance, and finally entirely rejected by a regime that sought control of both the individual's body as well as the state's institutional body. A strange dance or *danse macabre* of personal, institutional and governmental politics seemed to vie for control over the body, its identity and its ability to define a space in which to move freely.

The Dancers' Congresses of 1927, 1928 and 1930 organized by Laban and his supporters were major events designed to bring the major names in the field of the New German Dance together in a new *Hochschule für Tanzkunst* or Dance Conservatory. These conferences achieved much but also exposed many differences in the intentions and aesthetics of the many practising professionals. Mary Wigman did not attend the 1927 event and encouraged others not to because of a growing feud between her and Laban's organization. She felt that she was not properly recognized for her contribution to German dance in the Congress's activities. The 1927 and other

Congresses revealed an increasing social division that the Nazi propaganda minister Goebbels's later capitalized on by founding in Berlin the *Deutsche Meisterstätten für Tanz*, literally translated as German Master Institute for Dance. There, according to Manning (1993), the curriculum would emphasize its own National Socialist ideology.

At the first Congress in Magdeburg, Laban and his close associates, including Kurt Jooss, Sigurd Leeder, Albrecht Knust and Dussia Bereska, made significant headway in the development of *Schriftanz* (later called Labanotation), a system of notating dance movements for preservation and later reconstruction. *Schriftanz* was part of a larger conceptual plan that included Eukinetics and Choreutics, the former a study of movement effort and the latter of movement design in space. These studies reflected Laban's interest in producing an ecstatic unity of internal and external conditions of being. In the second Dancers' Congress in Essen, the ideological issue of space came up again, this time spurred on by strongly felt differences in what kind of dance should be taught within the network of amateur and professional education and performance systems in Germany. Wigman's part in the organization of the third Dancers' Congress in Munich during a German Dance Week demonstrated her growing power on the New Dance scene. Also noteworthy was that one of the new innovators in dance, Oskar Schlemmer, trained as a painter and sculptor, and disappointed in the response to his work, turned down his invitation to the Munich Congress. Wigman's adamant refusal to attend and Schlemmer's polite absence indicated an eerie transition in the German Dancers' Congresses of 1927, 1928 and 1930. The New Dance had barely begun, but it would soon be forced to go underground as the National Socialists sought to eradicate an aesthetic that threatened its own.

Laban's experience made it quite clear that only a narrow view of the body and of dance could exist under National Socialism. This view allowed little or no space for individuality, innovation and difference. The Modernist body, and by extension modern dance, became the site of a struggle for power between the inner and the outer, between abstraction and realism, and between the organic and the mechanical. Laban's system of choreutics, the tool he used for encoding and decoding the experiences of the performing body, encapsulates his ideas of the Unity of Body. He writes in the introduction to *Choreutics* (1966) that every human movement is perceived as experience in space, the "living architecture" of man's existential condition. This condition identifies the human being as a mentality "plunged into the intangible world



of emotions and ideas”, in which he or she is an objective observer, enjoying movement as bodily experience while attempting to observe and explain it from that position. The spatial, dynamic and rhythmic aspects of movement had complex emotional correlates that, like music, could be written out in a logical structure and repeatedly performed. He called this art or science choreutics, “the analysis and synthesis” of human movement potential.

Choreutics became a tool for the study of complex relationships between dancers and their movements in time and space. It attempted to describe and represent the spatial and temporal qualities of movement. What was initially termed Eukinetics was an attempt to describe the body’s effort through complex spatial diagrams based on one of Plato’s five “perfect” forms, the icosahedron.

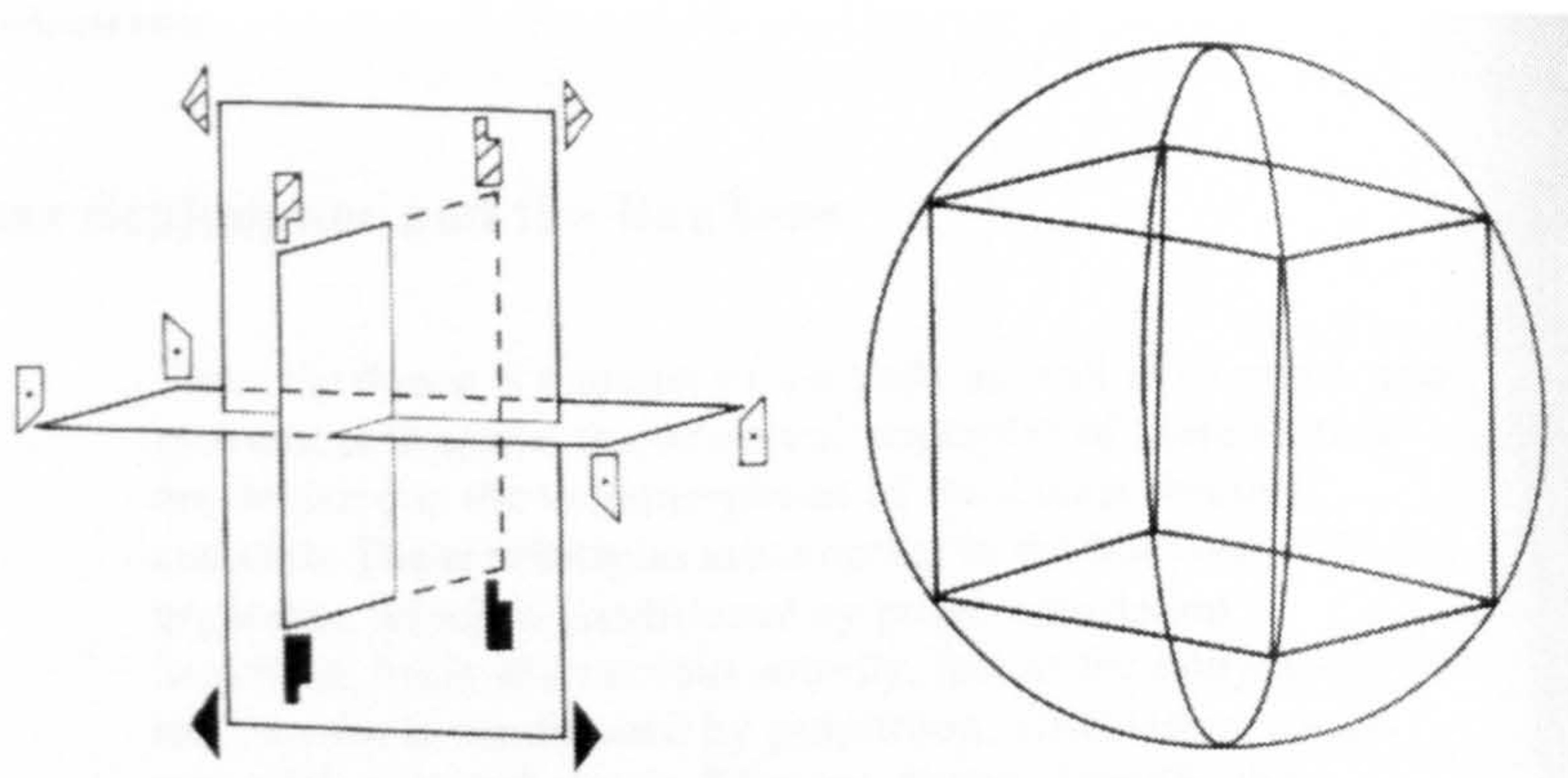

**Fig. 4 - Laban's Three-Dimensional Planes I** (Laban, 1966, p. 142)



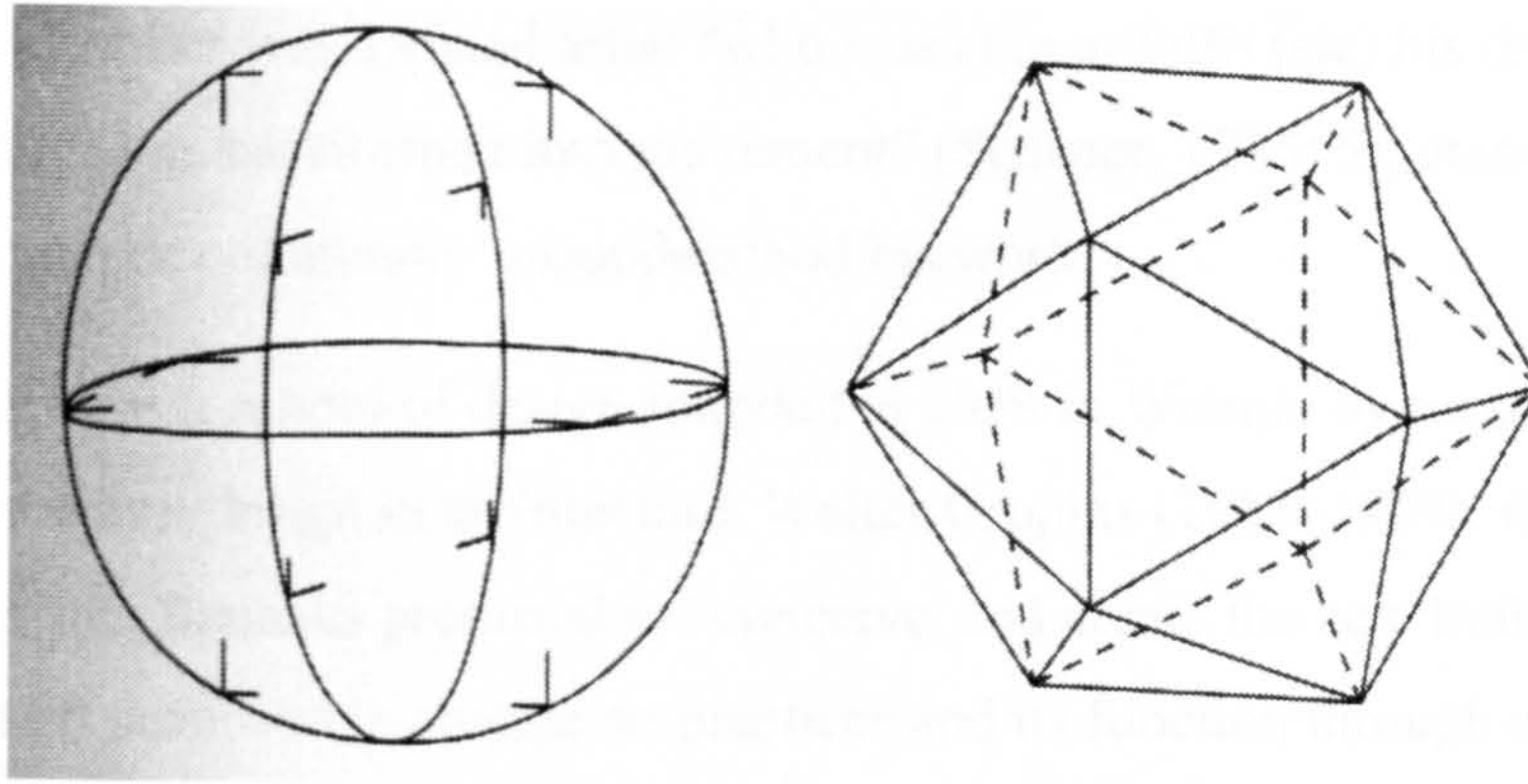

**Fig. 5 - Laban's Three-Dimensional Planes II** (Laban, 1966, p. 143)

Even though conditions in Germany, Italy and Russia were quite different, Marinetti, Meyerhold and Laban all considered the state of art and culture as lacking in originality and unrelated to society and the ordinary individual's needs. Their work would eventually influence artistic and cultural practices far beyond the borders of their own countries.

## 5.5 Oskar Schlemmer and the Bauhaus

Since the dance is a matter of the body as well as of space, and movement in space, the structural principles of these factors are decisive in the metamorphosis of the dancer through costume. These principles are inherent in the body-as-organism, which is conditioned by pulse, circulation, breathing, brain and nervous activity, just as the body-as-mechanism is conditioned by proportion, articulation, stress-potential, gait, and spring. They are further found in the organism space, which is conditioned by height, breadth, and depth, and they are inherent in the body's movement, which occurs within these spatial relations. (Scheper, 1985: 13)

Preston-Dunlop (1998) claims that Oskar Schlemmer (1888–1943) found much of the work in the 1927 Dancers' Congress second-rate. This could have been one reason he turned down an invitation to attend the second Congress in Munich a year later. Perhaps he sensed that his colleagues and the audience were not prepared for his kind of work, which was certainly not in the predominant expressionistic style. In Schlemmer's work, equal weight was given to set and costume design as to the movements themselves. His was a decidedly modernist stance, embracing the austere, abstract, practical and rationalist aesthetic of the Bauhaus. Perhaps because of this, and



because Schlemmer was a visual artist “who was able to fulfil (sic) his dream of seeing his pictorial vision transformed into movement” (Scheper, 1985: 5), many in the mainstream dance community misunderstood his work.

The Bauhaus was a school of design founded in 1919 in Weimar by an influential pioneer of modern design in architecture, Walter Gropius (1883–1969). Gropius’ Manifesto of the Bauhaus promised to “conceive, and create the new building of the future”. It also promised to change art practices and its function through an integration of the fine and applied arts. Gropius envisaged the Bauhaus as a cathedral of Socialism, actively sponsoring and promoting an integration of art, architecture and design in the spirit of modernity and universality. Schlemmer would complain in 1921 that Gropius was the only architect around and had no time for teaching a course in a subject he claimed was so necessary for his programme of change (Schlemmer, 1972). Gropius did have a vision, but it was left to the Kollegium of Masters at the Bauhaus to carry out the innovative programmes he envisaged. His claim that the ultimate aim of all creative activity is a building reflected the thematic of constructing anew, out of the ashes of the First World War. Gropius hoped that this building would eventually symbolise a new ideal by reflecting a strict geometry of forms, sleek machine-like aesthetics, economy of design and, above all, abstraction.

In the post-1914 and pre-1933 political climate of Germany, these were difficult objectives to accomplish. However, an international teaching faculty ensured that students were intimately acquainted with leading-edge practices in the art world. Schlemmer was probably the individual most actively working to promote the integration of art and performance. Scheper (1985) argues that Schlemmer saw his work with costume ballets as linked to a fundamental reform of the theatre, and that Schlemmer ignored contemporary stylistic movements in both painting and dance and concentrated strictly on his perspective as a visual artist relating form and colour to the geometrically defined cube of the stage and the human figure moving within it. Like Laban’s placement of this figure in a defined space and Jaques-Dalcroze’s use of rhythms within a system of movements, Schlemmer attempted to symbolically reunite body and spirit and re-establish an organic connection to a greater cosmological idea. Schlemmer rejected Expressionism: he was interested more in the mechanical aspects of the style but, opposed to reducing theatre to purely mechanical effects, he was also

interested in the human body's organic features. He felt that the movement design of bodies in space, and the positioning of bodies moving through space, facilitated a spiritual experience of art. The sensuality of dance interested him because it supplied something his painting lacked, and the latter gave him an intellectual pleasure that the former complemented.

In the designs for the 1922 choreography *Triadic Ballet*, Schlemmer presented the body as an idea of humanity: abstract, geometric and depersonalized. He had worked on parts of this ballet since 1916, at the same time as he was fulfilling various service appointments in the German military. His idea was to portray the individual as part of a universal system of reference. The *Triadic Ballet* was Schlemmer's way of working on a problem that preoccupied him throughout his career, namely, the desire to portray a metaphorical pictorial form for man and the world through abstract means (Schlemmer, 1971). In 1920, he noted that he was beginning to like dance more, something he had previously "denied and cordially hated" (Schlemmer, 1972: 82). Dance seemed to fill part of a gaping hole in his life that his preoccupation with totally abstract forms could not. Abstraction, he felt, was a transition to the life to which he wanted to commit himself fully.

Having rejected naturalism and adopted abstraction around 1915–16, Schlemmer claimed that his next change of direction came through a decision to move from the geometry of the one-dimensional surface to the half plastic and then to the fully plastic art of the human body. This plastic form, he believed, could not survive without a conceptual basis. Its identity, i.e., the unity of movement and bodily form he sought and longed for, seemed to come through dance. While he formulated these ideas, Schlemmer's life underwent momentous changes. As the war in which he fought ended, his sister Henriette died. He left the Academy of Art in Stuttgart and married Helena Tutein. He also befriended Paul Hindemith who would compose the music for his *Triadic Ballet*. Schlemmer's art exhibitions were successful, and he was offered an appointment to the Bauhaus faculty together with Paul Klee, who was only recently turned down for a post at the Academy in Stuttgart.

Running the stage workshop at the Bauhaus gave Schlemmer the ideal opportunity to experiment with his interests in the theatre and to develop an intellectual and theoretical basis for this work. It was here that his ideas for abstract and total dance



theatre, i.e., the *gesamkunstwerk*, were developed. Goldberg (1996) claims that Schlemmer's habit of considering painting the art form that most deserved his intellectual rigour and dance as the form that engaged his Dionysian pleasure displays a puritan ethic. Like the philosopher Friedrich Nietzsche, Schlemmer believed that two main forces for creativity guided the artist. These were based on the qualities of Apollo and Dionysius, two Greek gods. Apollo was the sun god and represented art and music and qualities attributed to him epitomized the Western aesthetic of beauty and intellectual satisfaction. Dionysus, on the other hand, was the god of wine and of madness, representing raw passion. Nietzsche's concept of "divine madness", an idea that appealed to many dancers and choreographers attempting to find a basis for their preoccupation with the simultaneous abandon and discipline needed to dance, embodied these opposing qualities.

Schlemmer used these concepts quite differently, however. In a letter to Otto Meyer in 1921, barely nine months after his appointment as Master of Form at the Bauhaus, he describes his own slow and painfully deliberate method of working and writes critically of Johannes Itten's "emotionally overcharged manner" in teaching students "Analyses" at Weimar (Schlemmer, 1971: 19–20; 1972: 107). Schlemmer did not agree with Itten's methods or his theoretical perspectives, even though they were very precise. It is reported that Itten and Gropius also disagreed on a number of approaches, one of which was the Bauhaus' production of commercial art and another Itten's insistence on preparatory meditation classes and the far-eastern mysticism it implied.<sup>7</sup> Itten's departure from the Bauhaus in 1923 marked the beginning of a new phase in Bauhaus teaching, one that was less "romantic". Although there was disagreement among the teachers at the Bauhaus, critic Heimo Kuchling would argue in his introduction to Schlemmer's *Man* that the real importance of the Bauhaus in the field of special art instruction lay in the school's teaching of certain creative means.

Writing again to Meyer, this time in June of the same year, he expresses happiness that Gropius had hired Lothar Schreyer for the Bauhaus Theatre Workshop, believing that the "illusionary world" that the theatre offered could be the outlet that people needed to distract them from the country's economic crisis. The theatre, he felt, could "play an important role among the subjects we treat" (Schlemmer, 1972: 107) referring, of course, to the human element. Thus, although Schlemmer abandoned naturalistic representation, he paid great attention to nature and humanity. The elements of



Schlemmer's theatre were simplicity of forms, movement of bodies in space, and colour and light in motion, all conceived within a complex architected universe. The space he saw was alive with energy, and matter contained energy that harboured consciousness. The human figure in space was thus a compendium of energy and consciousness, and through the sensual body and the intellect, the human being could come to know and be one with the environment.

It is essential for the 'new life', which should express itself as a modern feeling about the world and life, that man should be understood as a *cosmic being*. His conditions of existence, his relationship with the natural and artificial environment, his mechanism and organism, his material, spiritual and intellectual image; in short, man as a bodily and spiritual being is a necessary and important subject of instruction.  
(Schlemmer, 1971, p. 25)

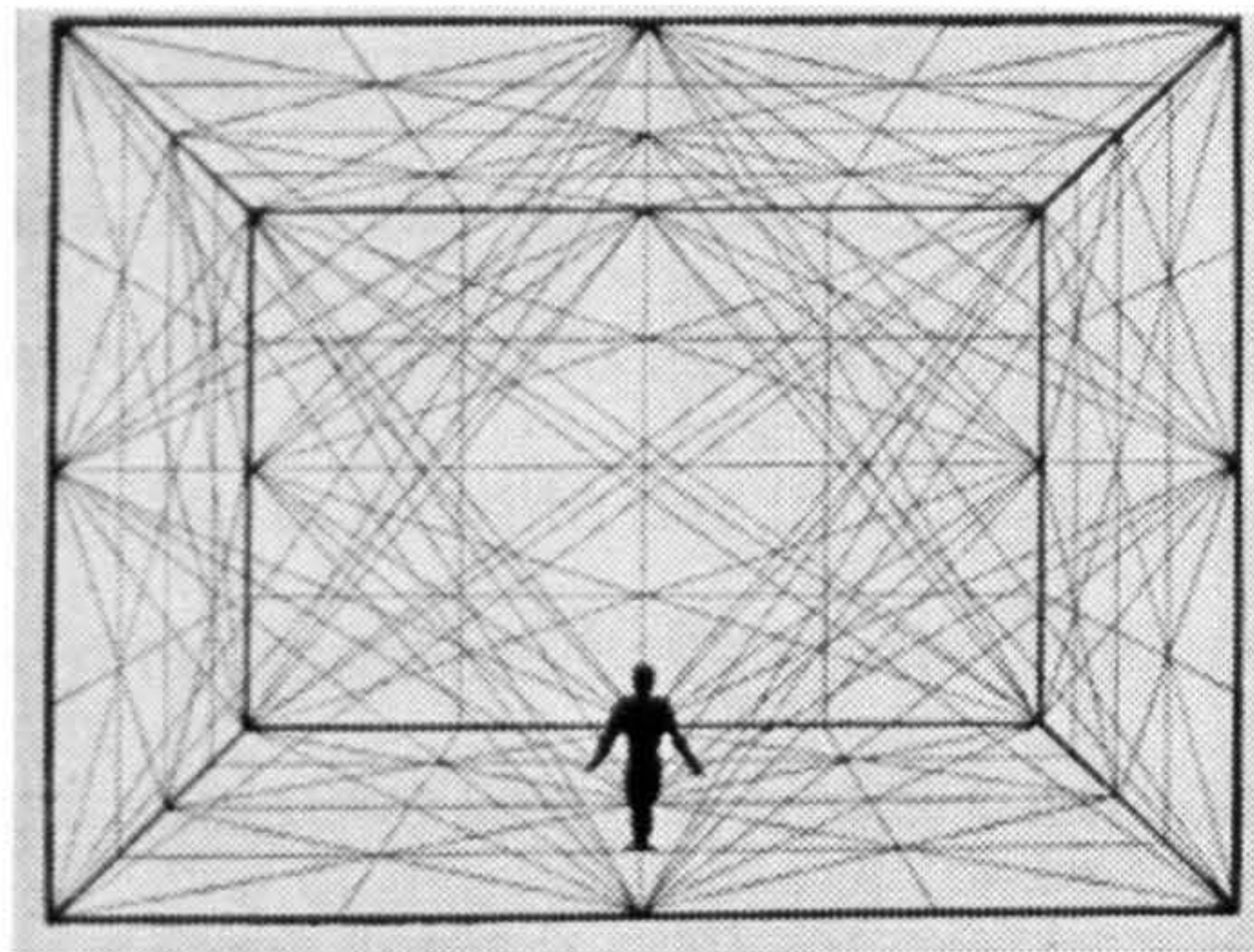

**Fig. 6 - Figure in Space with Plane Geometry and Spatial Delineations<sup>8</sup>**



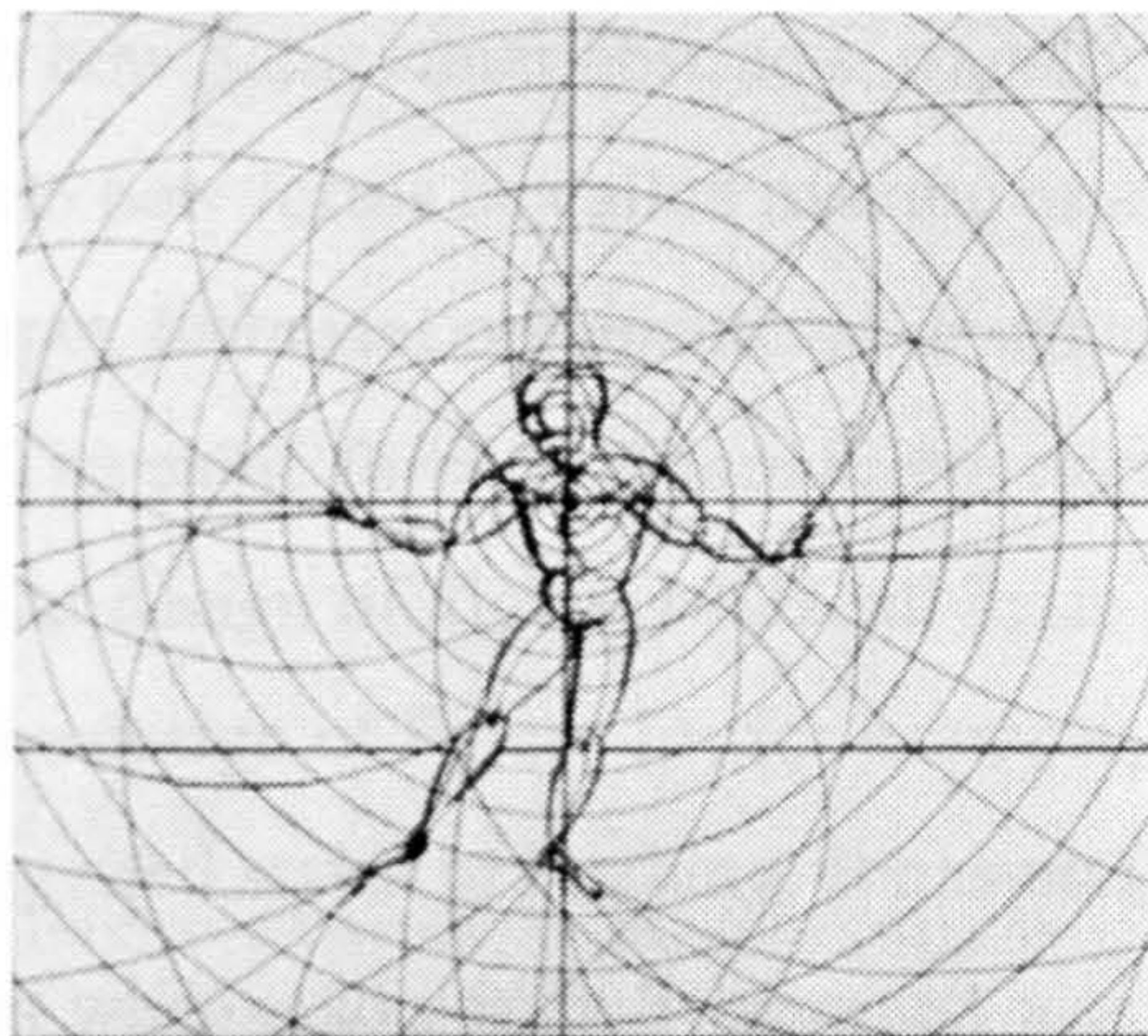

**Fig. 7 - Man as Dancer**

Figures 6 and 7 are preliminary sketches of a framework for the choreography of the *Triadic Ballet*. Together the two diagrams indicate how the physiology of the real body intersects with the strict perceived geometric lines of the box-like stage space. The movement of the body extends in space via the costume design to achieve resonance with the performance environment. These designs reveal similarities to the ideas of Rudolf Laban. Laban used the icosahedron instead of the square as the basis of his theoretical ideas, no doubt hoping to achieve more complexity in his movement vocabulary (see Figs. 4-5). His decision to use the icosahedron was based on its connection to an ancient Greek tradition. Laban clearly intended that the complex of ideas associated with the icosahedron and the Greek tradition would influence his movement perspectives by association.

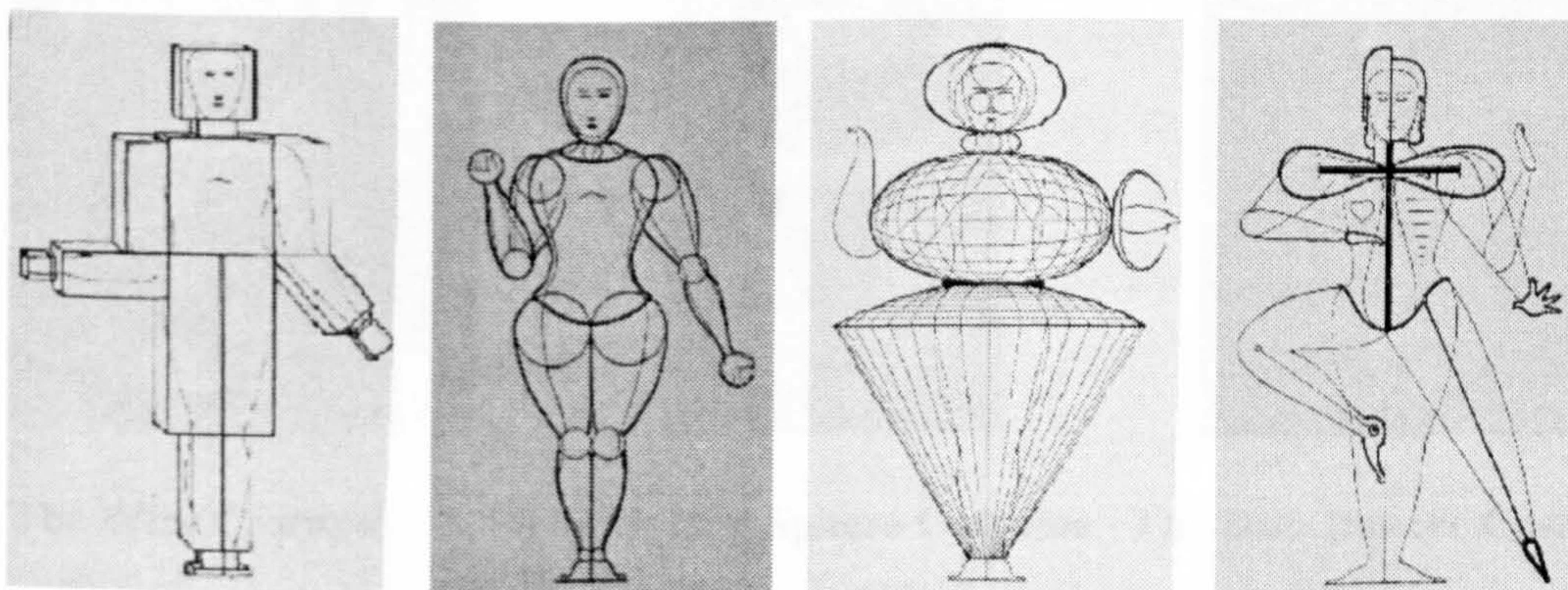

**Figs. 8-11 - Means of Transforming the Human Body by the Use of Costume**



Figures 8-11 demonstrate how Schlemmer abstracts, transforms or otherwise metamorphoses bodies into new forms he called moving or ambulant architecture, marionette or jointed puppet, technical organism and de-materialization. There is some humour in these figures. The cubic form of Figure 8, the circular shape of Figure 9, and the lamp-like triangular design of Figure 10, recall basic geometrical shapes that allude to human types. The design of Figure 11, for example, is a compendium of geometric shapes and suggested styles of clothing. It has no fixed historical location, no notable identity, except when read within Schlemmer's aesthetics. In all four designs, he sketches the underlying human figure behind or beneath its odd geometric characterisation. These figures belong to an aesthetic that, although shared by some contemporaries, Schlemmer alone implemented. The body-as-organism and the body-as-mechanism were never before represented on the modern dance stage in such an individual and consistently stylistic manner.

Although the bodies refer to abstract, depersonalized and mechanical forms in all the above sketches, the viewer is asked to look deeper and more attentively at how emotions, ideas and opinions influence their representation. In the *Triadic Ballet*, the masking of the recognizable human body and the representation of the body as an art object hides its "true" identity and refers to an "other" identity different from the human but closely identified with it. The structure of this dance is based on multiples of three: three acts, three colours, three dancers and three basic shapes. There were twelve abstract dances, grouped in threes around the colours yellow, pink and black.

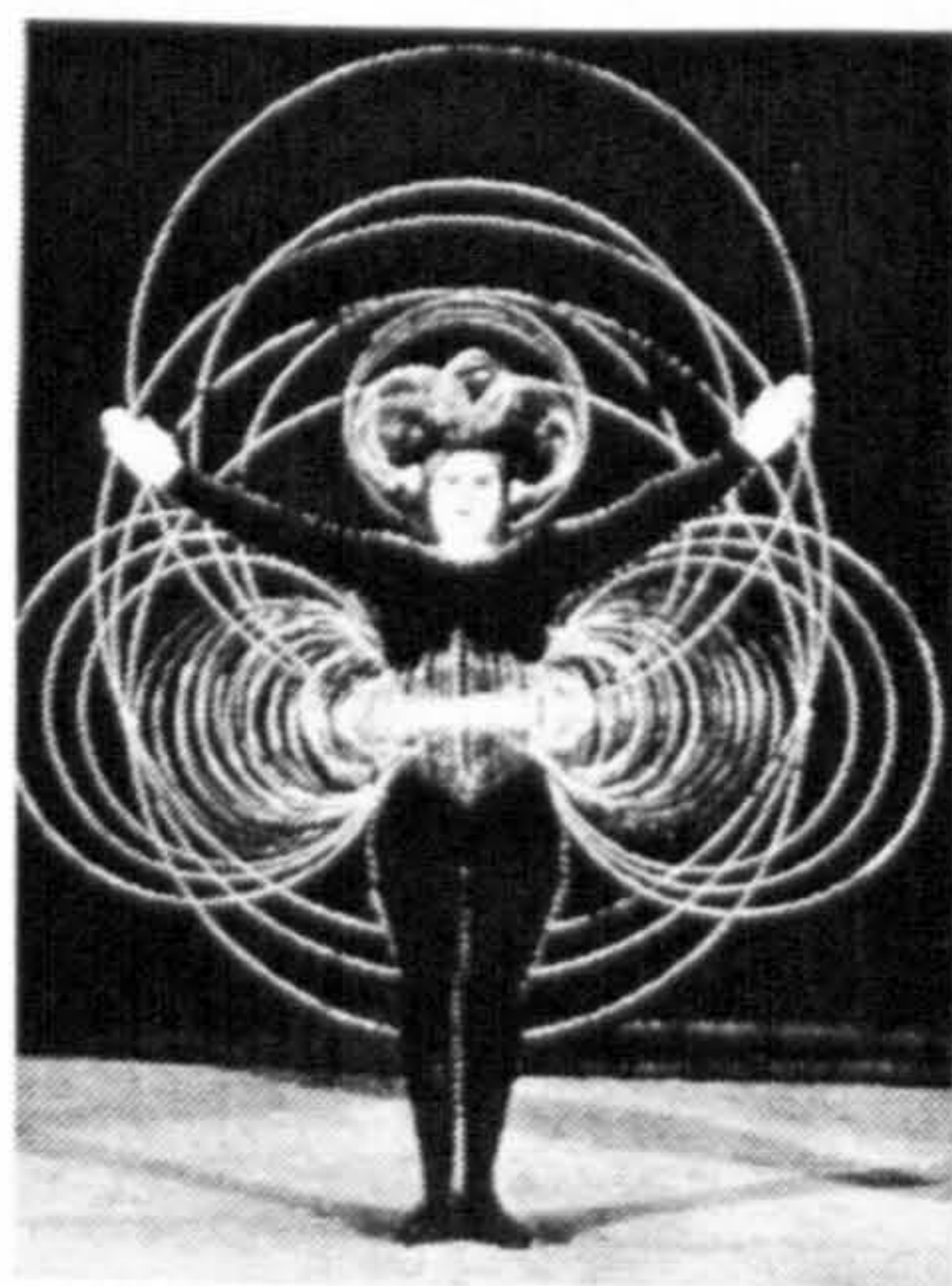

**The Wire Costume**

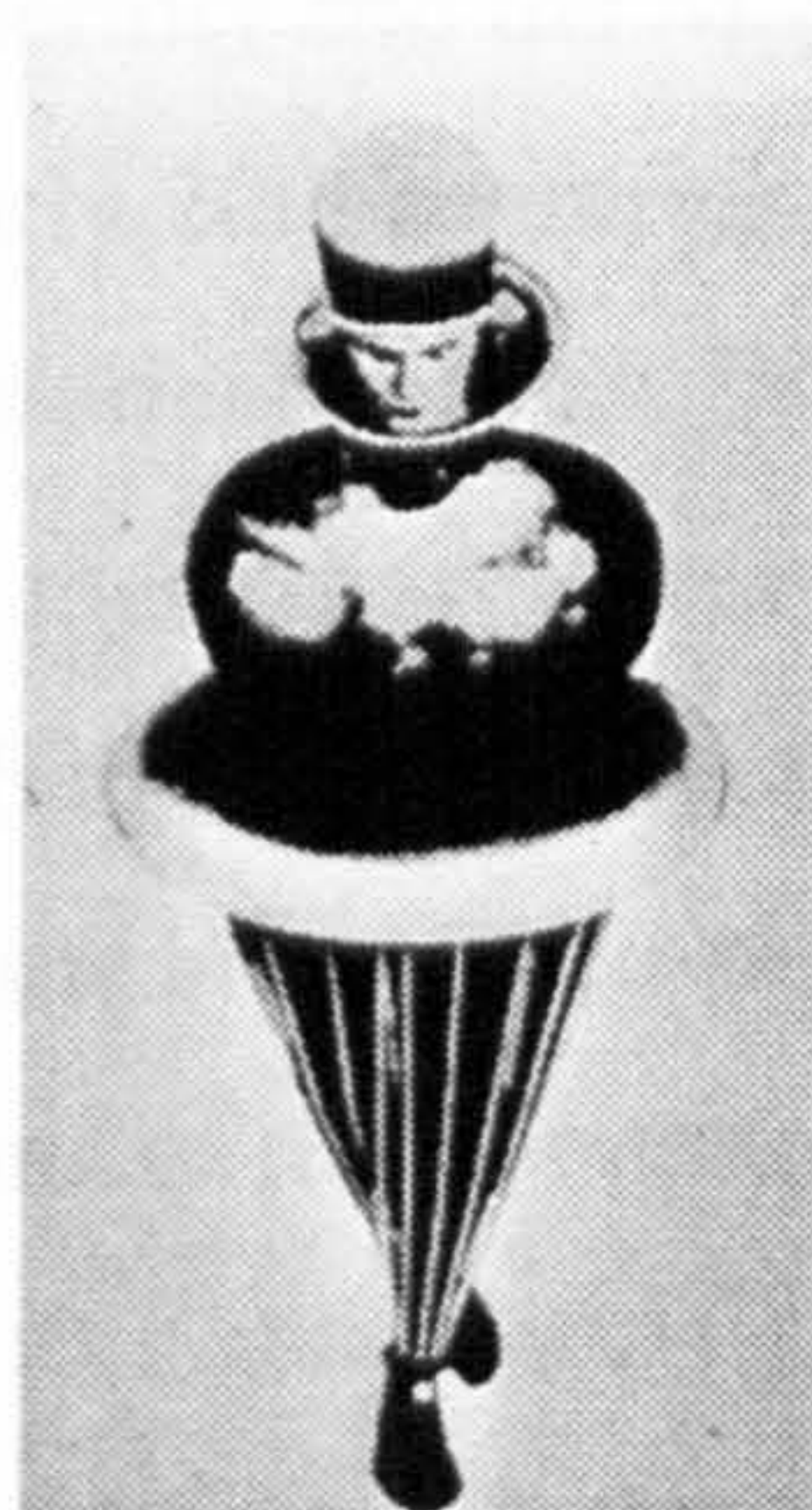

**The Golden Sphere Costume**

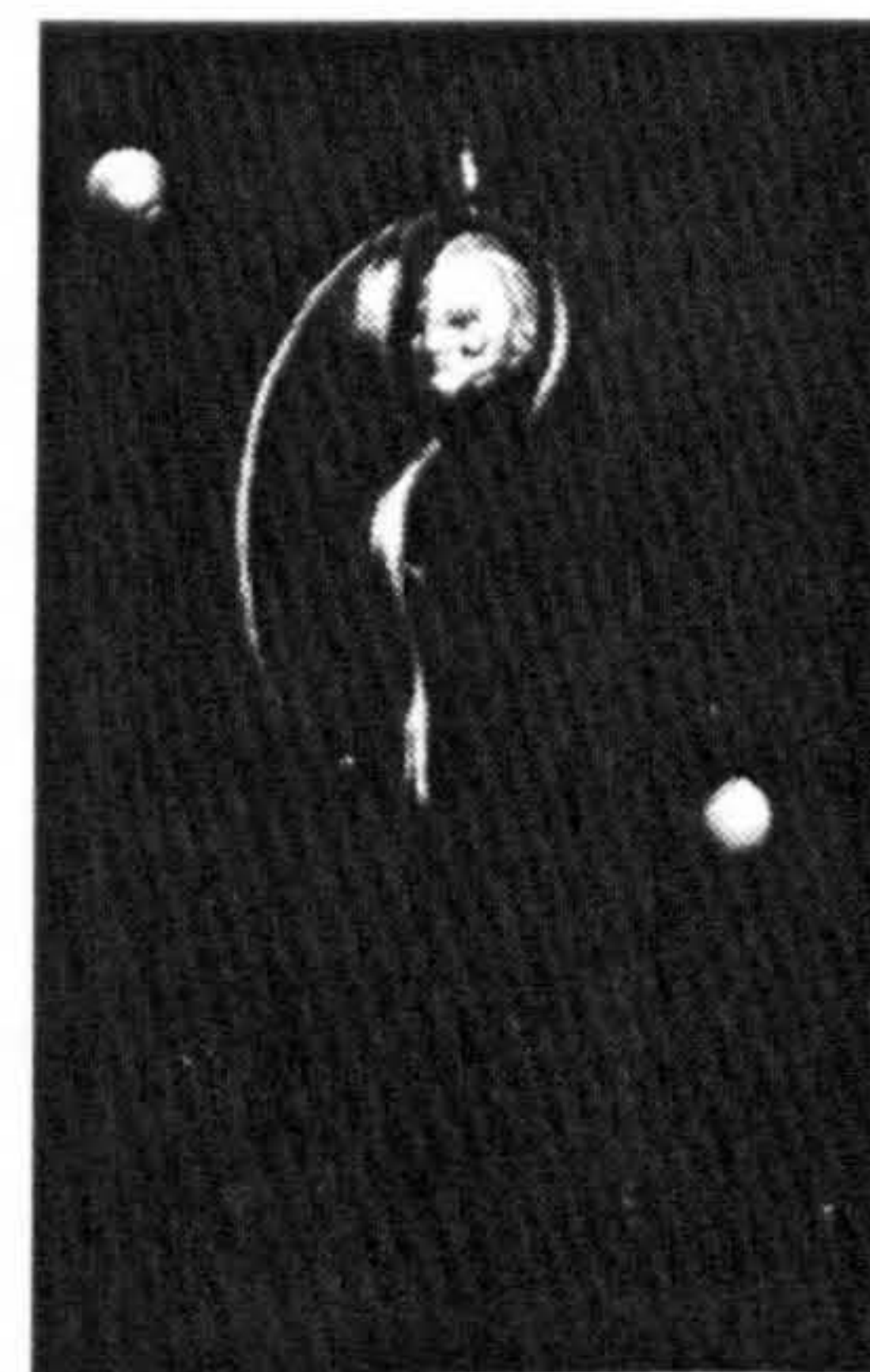

**The Disk Dancer Costume**

**Figs. 12-14 - Costumes for the *Triadic Ballet***



Schlemmer avoids obvious religious references in his designs, but theosophical ideas do appear in his work through abstraction. The *Triadic Ballet* identifies Schlemmer's allegiance to art as a substitute for mainstream religion or political affiliation. He clearly wanted his audience to have a logical, psychological and spiritual experience while viewing this work.

In 1928, just before his departure from the Bauhaus, Schlemmer would state that his future subject of instruction would be the human being (*Der Mensch*). He would approach this new subject through the study of "heredity, racial theory, reproductive biology, and ethics [...] supplemented by nude and figural drawing and anthropology [...] and theatre [...] and painting" all of which would form a "nice totality" (Schlemmer, 1972: 229). His time at the Bauhaus made him understand what was needed for the study of the human subject as art object with performance as a primary mode of enquiry. The tensions he experienced working between passion and abstraction drove him to develop an entirely new dance aesthetic. This new aesthetic would influence generations of choreographers and dance companies, including Merce Cunningham, Alwin Nikolai, Mummenschanz, Momix and Pilobolus. Although its growth was arrested in Germany, his ideas and those of the Bauhaus he helped form would find fertile soil in the United States, eventually developing into a new area of dance that uses complex technological machines.

## 5.6 Some Additional Conclusions

We have seen that the idea of modernity and the Modernist movement that rose to prominence in the late 19th and early 20th centuries was influenced by modes of thought and action from earlier historical periods. We have also seen that the Industrial Revolution played a part in giving these movements a significant new direction. Marinetti, Meyerhold, Laban and Schlemmer were all instrumental in generating new approaches to art, technology and the body. Their perspectives helped to give the term modernity some of its specific forms of representation and to outline new perspectives on things to come. Modernism, in its Futurist and Constructivist manifestations, was a youthful force that allied itself to technology because of its association with progress. The artists mentioned in this chapter all wanted to establish a new organic relationship to self within a society that was becoming increasingly mechanical.

In fulfilling these aims, some of them became political activists, seeking to institute change through new performance practices that used the body in new and exciting ways. Schlemmer helped free the dance from its dependence on emotional expressivity without turning to the overtly political. He also helped people appreciate the body as art. Performance expressed his ideas of human beings in space and time, and of motion and emotion united through colour, line, plane, form and sound. Laban believed that ancient Greek philosophical thinking on the structure of the physical cosmos and its effects on human behaviour still held credibility, and he used these ancient teachings to link the old and the new. His premise was that one could observe and document human behaviour in the same terms as the rest of the physical universe. As such, the individual's movement architecture could reveal the contents of an individual's psyche. Meyerhold made political activism an essential part of theatre's goal. In revolutionary Russia, it was no surprise that the notion of a machine-human-interface could emerge in the form of Constructivist theatre with a biomechanical movement aesthetic. Lastly, Marinetti's Futurist movement may have eclipsed other Modernist endeavours in its outrageous ideas and bizarre performance actions, but these were merely indications of what was to come in the postmodern and digital ages.

My own attempt to engage with the issue of modernity from a choreographic perspective is outlined in *Futurist Equation*. This work was created for a conference titled "Homo Orthopedicus" or "The Conception of the Body in the Modernist Age" convened by University of Antwerp faculty. The performance took place at Antwerp's Museum of Contemporary Art (*Museum voor Hedendaagse Kunst Antwerpen* or MuHKA). My purpose with this particular work was to draw attention to some of the more important ideas on the notion of a modernist body. As mentioned previously, these were 1) a condition of existing in the moment, 2) a condition of change, a state of constant flux, of upheaval and revolution, 3) an event located in historical time, as a state of newness, in the form of a particular aesthetic, and 4) as a process of development or maturation.

My experiences of living among people whose culture I did not grow up with and did not experience from a formative stage of life often gave me the impression of living in a contested space. Many of my experiences have been from the outside looking in. Often, it seemed as if the culture in question was impervious to those looking in, or at least it seemed as if the point was to make entry as difficult as possible. Coming from



one of the so-called Third World countries, I also found this place of possible interaction made more difficult by assumptions about my background. If early modern dance was a search for individuation in an increasingly complex modern world where the unknown challenged the individual to explore new terrain rather than succumb to stasis, I often saw my work as belonging to that tradition. Hence, the possibilities for interaction, for me, existed in exploring the cultural artefacts of that particular group, in a relationship to my own body, as well as those of the audiences who shared those contested geographical and psychological spaces. My process in trying to understand what modernity meant involved creating conditions within which points 1 to 4 above could be tested. Hence, my interpretation of the modernist body in *Futurist Equation* took into consideration notions of space, time and identity. This meant that the individual performers I chose to work with had to give themselves up to role-playing within a specific performance site and to interact with the artefacts or objects within that space. In short, my performance was an attempt to map the convergence of coordinates across time and space, without trying to find an immediate and comprehensible narrative. This, I felt, was worthy as an approach to the exploration of a modernist body or bodies.

Since the Futurist movement and its concern with technology interested me as a dancer and choreographer working with technology, I fixed my attention on *The Manifesto of Futurist Dance* as a starting point. The space projected for the work was MuHKA, a contemporary art museum in a city I would visit for the first time just a few months before the event. In that space, an exhibit of the work of the South African-born Dutch painter Marlene Dumas would occupy a significant position. Marlene Dumas paints mostly women, quite frequently from photographs of them. Her style is primarily Expressionist, concerned with the female figure and its identity. Many of those paintings struck me for their fascination with sensuality and the public and private appearances of females in all kinds of situations: the beauty queen (Miss January, 1997), the actress (Josephine, 1988), the shy woman (Schaammeisje, 1991), the child dressing up (The Painter, 1994), the pregnant woman (Pregnant Image, 1988-90), young girls (Turkish Schoolgirls, 1987, and The Dance, 1992). It therefore seemed appropriate for me to explore through the performance space a primary dichotomy, namely, the “noisy” pronouncements of a very male-oriented movement in the first decade of the 20th century and the relatively “quiet” artistic statement of a Caucasian

South African woman who chose to live in a European country that had strong cultural and colonial links to her country of birth. The primary intention in the piece can be described as follows: If modern dance identifies the choreographer as the primary actor in a search for individuation through the exploration of the corporeal, my task was to implicate as many others as possible in my search.

Thus, the six points outlined at the beginning of this chapter identifying some of the primary conditions under which modernity operated came under choreographic scrutiny. Additionally, I strove to reinterpret the main artistic concerns under which the work of Marinetti, Laban, Meyerhold and Schlemmer could be analysed. These concerns — 1) Industrialization and modern city life, 2) Dynamism, simultaneity and interpenetration, 3) Mechanical art, 4) Theory of the body, the marionette and the automaton, and 5) Dance — helped to redefine my practice as a 20th-century dance artist attempting to establish an organic relationship to self within a technological society that, to suit its purposes, either denies or appropriates elements of my and/or other people's culture. The conflicting identities that emerged indicated to me a crisis of body, one that reflected the state of our institutions, our personal bodies and the bodies of media information that threatened to overwhelm the individual at the beginning of the 20th century and again threatens the individual at the start of the 21<sup>st</sup>.



## Chapter VI The Body in Crisis

### 6.1 The Body in Crisis

Perhaps conquest provides the most appropriate frame of reference through which to view the cyborg's most recent computer-based transformations since its new form is the product of a special problem in human adaptation: namely, how to exist *in* an environment that consists of pure information. The answer is, as Wiener first pointed out, provided by cybernetics: one transforms the human organism into a pattern of pure information. Adaptation is, as a result, perfect and complete since organism and environment are conceived in similar terms. (Featherstone and Burrows, 1995: 39–40)

In the last chapter, I explained how, in the first half of the 20th century, notions of modernity and an urge to progress gave rise to new forms of art with different ideological bases. Artists greatly expanded the range of their expressive, technical, stylistic and thematic vocabularies to the extent that, by the end of the century, it became clear that Modernism was merely the beginning of a much larger movement destined to reshape relationships between art, science and technology. These developments brought increased knowledge of the biological body and its cybernetic possibilities. Science and technology exerted a tremendous influence on the performer's expression onstage by allowing artists to transcend the limitations of previous treatments of space, time and body. In short, artists were discovering new ways of defining themselves in relation to machines (Dyens 1999: 10).

Some of these new possibilities arose because of the Internet, as cyberspace became the most challenging new frontier where notions of a machine-human interface were being defined. Telepresence, the experience of being present at a remote location, was one of a number of new applications explored. Choreographers like William Forsythe, Bill T. Jones and Merce Cunningham transformed contemporary dance and classical ballet vocabularies, their work speaking profoundly of issues grounded in different perceptions of body. It is certainly not a stretch of the imagination to conclude that the old aesthetics were revitalized, and issues like identity politics, social alienation and cultural marginalization achieved greater significance as choreographic themes.

Many saw these developments as evolutionary in scope, a ray of hope to lighten the dark and alienating landscape of the late 20th century. Others felt that the technology

itself was an alienating force responsible for making humans feel as if they were strangers in a universe “filled with accidental by-products of a blind evolutionary force” and with no meaningful relationship “to the inexorable forces that drive on the larger world of brute, insensate matter’ (Zohar, 1991: 1). Zohar voices a concern that is explored by performance artists like Stelarc, who claims that our bodies are intimidated by the precision, speed and power of technology, and that we are biologically ill equipped to cope with the new extraterrestrial environment that is rapidly opening up before our eyes.<sup>1</sup> He ascribes the problem to the body’s lack of proper modular design and argues for a post-evolutionary strategy to deal with what he sees as inadequacies. Stelarc also suggests that human evolution is either too slow or incompetent to help humanity out of its current predicament (See complete text of interview with the artist in Ch. VII). A new “post-human” species is needed, a high-tech combination of human and machine in the cyborg. Historically speaking, the ideas of Norbert Wiener (1894–1964) had a great deal to do with these developments.

Wiener was the scientist who, in 1948,<sup>2</sup> coined the term cybernetics, inspiring many to reconsider the relationship between humans and machines and to take active steps in resolving some of their perceived differences. Because of these activities, some exciting interdisciplinary explorations and novel practices between the sciences and the arts began to emerge. Cybernetics’ main directive of communication, information and feedback would become a central thematic in this new hybrid form that attracted scientists and artists alike. Wiener’s promotion of cybernetics as the science of complexity also assured it a prominent place in post-war interdisciplinary university-based research programmes. He even proposed that it become a model for, and a methodological approach to, interdisciplinary studies among the sciences. Cybernetics would follow an interesting route within the arts, helping to create a new and dynamic cultural space that would challenge the social order. It would also introduce a new existential dilemma, namely, how to deal with changing notions of the body and how to reconcile these with our “lived” and remembered experiences as human beings.

## **6.2 Cybernetics, Cyberspace and the Cyborg**

Cybernetics has been defined as “the science of control and communication in complex electronic machines like computers and the human nervous system” (Featherstone and Burrows, 1995: 30). Its development was initially tied to military



research, which allowed it to become a strategic tool for governments in maintaining the balance of power in a post-Second World War environment. It also provided a welcome stimulus in building a stronger economic base for modern society and later on achieved a growing influence in higher education outside the traditional technical disciplines. Cybernetics inspired a generation of writers to develop a visionary future for humanity in which a cluster of technologies have in common the ability to simulate environments within which humans could interact with non-humans (Featherstone and Burrows, 1995). Cybernetics also brought ancient spiritual and/or Shamanic practices under renewed scrutiny in the new science fiction, a form that appeared to legitimize a kind of New-Age spiritualism.

There are generally two basic forms of cyberspace: Barlovian cyberspace, with its attendant Virtual Reality (VR), and William Gibson's computer-based matrix. The former is grounded in the international network of computers known as the World Wide Web and the latter is a computer-based "matrix" in which humans and other post-human and artificially intelligent creatures interact. John Barlow, a former lyricist for the rock band Grateful Dead and co-founder of the Electronic Frontier Foundation (EFF), called his cyberspace "a series of transactions, relationships, and thought itself, arrayed like a standing wave in the web of our communications", a world that was "everywhere and nowhere, but [...] not where our bodies live" (Peltola, 2003).<sup>3</sup> Science fiction writer William Gibson describes cyberspace as "a consensual hallucination experienced daily by billions of legitimate operators, in every nation" (Gibson, 1984: 51).

By creating expanded notions of existence in space, time and materiality, cyberspace precipitated an immense shift in our perception of ourselves and of the world around us. It also affected contemporary views on how culture develops and the role that human awareness plays in this process. In his essay "Feedback and Cybernetics: Reimagining the Body in the Age of the Cyborg", David Tomas points out that a set of etymologically related terms function as the basis of a new kind of interdisciplinarity in the arts. Tomas claims that, according to the scientific logic of feedback, cybernetics has powers to unlock passageways between "disciplinary domains, machine and biological systems, and, perhaps most significantly, consciousness and creativity" (Featherstone and Burrows, 1995: 21–43). The disciplines he cites include music, art and poetry. There is no mention of dance, but this is hardly surprising, as

many writers tend to shy away from commenting on artistic performance involving body practices. This avoidance always seems to me somewhat strange, since we all possess the primary equipment from which informed comments can be made. I suspect that this hesitance is directly related to the notion that the sensual body is notoriously difficult to assess through traditional rationalist modes of thinking.

At the beginning of this thesis, I argued that corporeal recognition is the basis for a creative exchange between audience and performer. I also argued that a more profound connection to the body is necessary when technology mediates this exchange.

Wiener's argument that the age of communication and control requires actions to be guided by an economy of energy rooted in the accurate reproduction of a signal means that the idea of an intelligent body is one that has excellent memory of its past actions. Since accuracy of reproduction in the context of technology translates into an ability to recall experiences at will, memory takes on new meaning as a commodity. Thus, a technology that purports to read, write, describe and/or inscribe any aspect of body also becomes a tool for re-cognition. At the computer-human interface, "decisions" are made from a confluence of data and actions get carried out via intelligent "operators". "Actors" use specific mechanisms and systems for interpreting the data in meaningful terms. Thus, one can conclude that a cybernetic automaton that is hierarchically governed, self-regulated and goal oriented, and is bound through a particular time/space logic to its environment, possesses a form of agency (Featherstone and Burrows, 1995: 24). Wiener's ideas marked a new threshold in intelligent computing that was different from Alan Turing's. His use of servo-control mechanisms to allow the automaton to learn "in" action as well as "from" past action was quite revolutionary for its time. This learning process, Tomas argues, helps define the concept of life to bring it in line with what he calls a *cybernetic* automaton's "operational characteristics". It also changes the commonly accepted mechanistic view of life in favour of a more human-friendly one.

The new ideas that cybernetics introduced suggested that the relationship between base matter and subtle intellect was not mutually exclusive, as Descartes had presumed. Indeed, contemporary science operates on the principle that what we perceive as matter is actually a framework of electrons assembled together in a particular form and is far from being insensate. In short, we, in our consciousness of self, are sensitive to that realm's intricate workings. Zohar claims that a marriage of physics and



psychology would allow us to live in a universe where “we and our culture are fully, and meaningfully, part of the scheme of things” (Zohar, 1991: 7). Her use of quantum theory’s Principle of Complementarity<sup>4</sup> and the Uncertainty Principle<sup>5</sup> is an argument for a physics of consciousness that could furnish a crucial link between thought processes and quantum processes. She also claims that since most of medical human psychiatry deals with treating problems affecting consciousness by regulating the primitive forebrain, consciousness cannot be identical with the higher brain functions permitted by neurone connections in the cerebral cortex.

Zohar argues that the *form* (her emphasis) that consciousness takes is influenced by these connections, but the capacity for consciousness itself is far more primitive than the developed human brain and is a mechanism that is equally available to the human being and the amoeba. In her opinion, the parity between the physical basis of consciousness and the place and the reason for human consciousness may well be the evidence to support our understanding of what distinguishes life from non-life. If, as Zohar suggests, the secret of life lies not in the higher brain where the intellect is situated but in the lower forebrain where more “primitive” instinctual behaviour lies, then our attempts, as potential progenitors, to create life in the cyborg appear all the more attractive. Her explanation for this biological/psychological interface and her arguments for a physics of consciousness draw attention to how the mechanisms of life may operate at the boundaries of consciousness. At the same time, an important connection is established between human bodies as complexes of memory and the planet on which we live as an enormous mass of “memorized” data.

The key point here is that the body reflects the mechanisms in the world, and for many choreographers, the resultant movement behaviour is enough to stimulate their creative interests. Additionally, when scientists and technologists develop new tools to map, monitor, probe, or otherwise investigate the human body, these same tools automatically become the focus of the artists’ curiosity, one could say by default. Merce Cunningham, for example, has always maintained that his work is strictly about movement possibilities in space and time (Cunningham, 2004). The unfolding of his aesthetic is, therefore, extremely important to consider in light of previous arguments relating to the notion of a “lived” experience and the tendency toward abstraction in the development of a “post-modern” dance aesthetic.

### **6.3 Dance, Technology and the Crisis of “Abstraction”**

Dance critic Patricia Boccadoro gave a scathing review of Merce Cunningham’s spring 1998 season at the Palais Garnier in Paris. She wrote:

When there is no emotion in a piece, only abstraction, there’s little room left for development and expression and it appears Cunningham, even with his excellent troupe, can go no further. His ballets now all seem much the same to me and I’m afraid I miss any subtle differences. Art must express; it cannot be all void and emptiness. Merce Cunningham, whose works neither lift nor transcend, said what he had to say twenty years ago (Boccadoro, 1998).<sup>6</sup>

The first sentence of this quotation gets to the core of the Cunningham aesthetic. It also asks us to consider if there is indeed a creative crisis of development in the choreographer’s work and if so why. The first issue is, of course, Boccadoro’s mention of a lack of emotion and development of expression. The words “void” and “emptiness” are quite significant in this respect. Merce Cunningham belongs to, in fact, promoted and developed, a tradition in dance that moved away from obvious narratives and displays of emotional suffering. The emptiness that Boccadoro mentions is a direct consequence of consistently pursuing this aesthetic. The more important question, to my mind, is whether there are other, perhaps more subtle, levels of “emotion” and “narrative” that exist in such work. (If so, how can an audience perceive and appreciate them?) Boccadoro claims that there were none at the time of her review and that there had not been any for a long time.

When Robert Dunn started his dance composition classes at the Judson Memorial Church in New York City in 1960, he introduced a range of new and unusual choreographic devices and compositional strategies (Banes, 1987) based on some of the chance procedures that John Cage taught to his music composition students (Dunn was one of these). Merce Cunningham also used some of these techniques in his choreographic processes, and many of the dancers who took Dunn’s classes were ex-Cunningham Dance Company members. Before the first public performance of the Judson Dance Theatre collective in 1962, Merce Cunningham was the main practitioner of what became “post-modern” dance in the USA. In fact, he and John Cage were the catalysts for the movement. After 1962, a host of new choreographers with more radical ideas would unleash their visions on a sometimes unsuspecting public. Banes (1987) observes that the post-modern in dance was, in many ways, similar to the Modernist movement in the other arts, meaning that it had all the



hallmarks of that movement's revolutionary spirit. Franko (1995) also comments that post-modern dance's most salient trait was a shift from expression as a spontaneous act to expression as semiological system which deliberately marginalized expressive intent.

Reputedly, one of the most important strategies for making new choreography was the notion of chance operations, which Banes (1987) suggests constituted an escape from "the domination of hierarchical authority" and the type of suffering that was prevalent in modern dance at the time. Leaving certain structural decisions open to chance when making a work ensured that subjectivity was reduced. Unintentionally redistributing chunks of material, movement ideas and even individual steps also helped.

Choreographers like Dunn also used different constructs of time to affect the spatial characteristics of the moving or completely still body, i.e., time was broken up and superimposed on one object rather than another to change the individual's attitude to the dance's subject or object. We are told that Dunn understood Laban's *Schriftanz*, for example, as graphic, i.e., written inscription, from which movement activities could be generated (Dills and Albright (2001). In other words, Laban's scores could be used to invent, rather than merely interpret, dance. This statement is significant in that it indicates the new techniques and approaches that were used in choreographic construction, techniques that would later take on new meaning when used in the context of new technologies.<sup>7</sup> The point to all this is that the attempt to go beyond the traditional modern dance approach (something of a contradiction in terms) sacrificed emotional and narrative elements through different "processing" techniques.

Sometimes, but not always, this processing ensured that those elements never emerged at all.

The reader will remember that in my introduction to this thesis, I mentioned that the technological is a mode of operation that involves people synthesizing processes into techniques and tools, which, over time, become institutionalized as part of society's collective cultural memory (p. 13). I have since argued that the development of new forms of technology can be seen as an attempt to influence cultural evolution, an attempt apparent in the development of modern dance as it transformed itself into "post-modern" and later contemporary dance. It is not surprising that during the 1970s and 1980s, new levels of abstraction and methodological analysis began to emerge in American theatre dance. This trend in the use of the body as art and the gravitation

toward technology as a tool in making new forms of art had some of its roots in a Bauhaus aesthetic. Oskar Schlemmer's experiments in the 1920s and the Cage/Cunningham experiments at Black Mountain College in the mid-1950s and 1960s are, therefore, related in more ways than perhaps acknowledged. The lack of emotion and preponderance of abstraction that Boccadoro comments on in her review charts a history of expression versus abstraction and of tradition versus modernity that exists throughout the development of contemporary dance. In her claim that art must express, lift, and transcend rather than be all void and emptiness, Boccadoro was in effect saying that these developments towards abstraction had come to their natural end, as the lifelessness of Cunningham's work suggested.

The works presented in the Merce Cunningham Dance Company's Paris programme included *Rune* (1959), *Scenario* (1997), *Pond Way* (1998) and *Garnier Events I and II* (1998). The third work, in true Cunningham style, was a special arrangement of sections of older works. Boccadoro would not have seen *Hand-drawn Spaces* in Paris, a collaborative effort with Paul Kaiser and Shelley Eshkar. This work premiered in July 1998 at the SIGGRAPH conference in Orlando, Florida, just four months after Cunningham arrived in Paris. The piece was billed as a multimedia art installation in which motion-captured hand-drawn figures perform intricate choreography in 3D with the live dancers onstage.<sup>8</sup> A year later, Cunningham would invite Kaiser and Eshkar to work on *Biped*. This latter work premiered just after the choreographer's 80th birthday in 1999. In a review "Where Flesh Meets Form" (October, 2000), Sanjoy Roy comments that the dance took place on two planes, the human and the digital, and that "transfiguration" appeared to be the key idea expressed. The same dancers are in both planes: their real bodies in the gravitational plane and their "captured" bodies in the cyber plane. *Biped* acknowledges that the dancers are two-footed creatures that can be transformed into computer animations that move in a cybernetic environment. The animations are much larger than the dancers' real bodies and have a different kind of presence. Roy claims that the work achieves a "visionary scale".

Rarely has the encounter between the animate and the animated been presented more lyrically than here. *Biped* is a work to get lost in, an almost mystical place where flesh meets form, and, by extension, where body meets spirit. ("Where Flesh Meets Form", *Danceservice*, 2000)<sup>9</sup>



The startling difference between these two reviews makes the reader question the context of the two reviewers' arguments. Even though the pieces reviewed are different, the choreographic intentions are similar. One writer argues that Cunningham's work attains a visionary status while the other claims that little room remains for development and expression. In claiming that art must express, Boccadoro suggests that this expression must appeal to the audience's emotional life. Most people agree that Merce Cunningham is concerned more with the possibilities of movement as the primary source and inspiration for dance. However, the two issues are not mutually exclusive. The point is that one does not have to outline a clear narrative of human suffering for the viewer to have a complex human experience.

What causes these two reviewers to make widely different prognoses of Cunningham's work hinges on a perfectly legitimate human desire to make sense of what we perceive by attempting to connect it with what we already know from memory. The technology that allows *Biped* to crudely depict the same human bodies moving simultaneously in two dimensionalities also appeals to a part of the viewer that desires and/or sympathizes with such an experience. Whether it was the real or the virtual body, or a combination of both, that evoked the sense of mystery that Roy experienced is an interesting point to consider. Whatever the case, digital technology is clearly able to assist the viewer in experiencing different, perhaps completely new, perceptions. Since *Biped* was an opportunity for viewers to nourish their awareness with new perceptual food, we can surmise that Boccadoro failed to detect any subtleties in the works at Cunningham's 1998 Paris season because the context did not trigger anything in her "lived" response field. Roy saw something visionary because the virtual characters that were technologically generated and projected onto a transparent screen gave the impression of "flesh" meeting "form". The key to both views is not just context but also an ability to connect one experience to a store of other "lived" experiences and to enrich one's awareness in the process.

Boccadoro questions the continued viability of Cunningham's dance legacy because of the absence of emotional content. Her argument that there is little room for development in Cunningham's approach to dance flounders because, as we have seen, there is indeed room for development, and it has come about in three ways: first because of new technology, second because of a change in the individual's ability to grasp a more comprehensive perceptual field, and third because of a widening of the

viewers' conceptual and perceptual frames of reference. Even though Boccadoro may not have seen *Biped*, and perhaps may not agree with Roy if she did, she does admit that Cunningham's work is "essential". What exactly is essential she does not clearly state, but one assumes that she means essential to the history and development of contemporary dance.

William Forsythe's transformation of the classical ballet's vocabulary and its traditional emphasis on narratives is another area in which technology has been able to influence dance and our perceptions of bodies. I noted earlier in my references to *Futurist Equation* that the artist often attempts to come to terms with the entirety of a larger "evolutionary" or "cultural" body by drawing on, as well as recontextualizing, notions of personal space, time and identity. Forsythe has produced a number of pieces that touch on alienation, displacement and notions of the "other". One of his earlier works, *Alie/na(c)tion* (1992), explores the theme of social alienation through movement, words and images as part of a complex choreographic statement. What is interesting here is the manner in which the work is staged, namely as a discourse of the body that relies on words to help convey as well as mask potential meanings. Some of the text for *Alie/na(c)tion* is graphically represented below:

tiny spinning thing  
**oh my god**

alone in the mud, yes  
the dark, yes  
sure, yes  
panting, yes  
someone hears me, no  
no one hears me, no  
murmuring sometimes, yes  
when the panting stops, yes  
not at other times, no  
in the mud, yes  
to the mud, yes  
my voice, yes  
mine, yes  
not another's, no  
mine alone  
yes  
sure, yes  
when the panting stops, yes  
on and off, yes  
a few words, yes  
a few scraps, yes  
that no one hears, no  
but less and less  
no answer  
less and less, yes.<sup>10</sup>



*Alie/na(c)tion* is simultaneously “pop art”, “high art” and socio-political commentary. It uses popular culture within the framework of a deconstructed classical ballet technique. The work was created to be performed in a traditional Opera House, a location associated with certain types of work and audiences, both related to the modern commercial and financial centre that Frankfurt represents. Many people in this metropolis are at best ambivalent and at worst hostile to the performance work that has been produced there over the last twenty years. Thus, one can well imagine the variety of responses elicited by work that shifts from the sensuality and physical abandon of the popular rock/blues/soul musician Prince’s *Kiss*,

.....you don’t have to be rich  
.....to be my girl  
.....you don’t have to be cool  
.....to rule my world

to the *angst* of drug addiction:

is my living in vein? is my dying insane?

In addition, Forsythe’s veiled comments on his situation as director of a prominent ballet company in the ultra-modern financial capital of a re-unified Germany, i.e., Frankfurt, set up the terms for a discourse on the relationships between information distributed across different bodies and information sensed and/or focused through the individual.

*In Frankfurt ist es sehr heiß.  
Dieses Land liegt in der Wüsten  
region Nord Europas, wo es fast niemals regnet  
und die Lebensbedingungen für Mensch und Tier sind sehr  
hart.*

Translated literally, the text reads: “Frankfurt is very hot. This country lies in the desert of Northern Europe where it almost never rains [...] and the conditions for humans and animals are very hard”. In spite of all this, the choreographer reassures audiences that

everything will be all right.<sup>11</sup>

The more than two-hour long *Alie/na(c)tion*, like many of Forsythe's pieces of the 1990s, is a multimedia event that features computer-mediated and/or programmed sound, video, text, costuming, lighting and set design, as well as classically trained dancers who exhibit one of the most "contemporary" movement vocabularies available today. In these textual fragments, Forsythe reveals the alienation that the "other" experiences, the *Ausländer* who does not quite belong and the individual who cannot conform. The text also reveals bodies in crisis: the physical body in torment through drug addiction; the individual's alienation in a modern metropolis; the institutional body that imposes demands on the individual; the body of work that opposes the classical ballet canon in technique, style and concept; and finally the individual body's experiences in attempting to re-cognize this complexity within itself. These examples of bodies in crisis draw attention to my primary argument that technology plays a significant role in influencing contemporary dance and new performance practices, hence challenging our notions of bodies and the social, cultural and political contexts in which they are perceived.

Nowhere is this fact so apparent as in the work of Stelarc, the performance artist mentioned in a number of places throughout this thesis, whose poignant statements I have used to underline my arguments. Stelarc challenges all current notions of dance and performance art, problematizes relations between science, technology and art, and reconfigures other disciplinary foci. Neither the strong social and cultural commentaries in the work of Bill T Jones, the building of a "post-modern" tradition by Merce Cunningham that challenged established practices, nor the deconstruction of the ballet aesthetic through socio-political commentary in the dances of William Forsythe prepares one for the bizarre mechanized pyrotechnics that characterize Stelarc's work. His perspective, as he claims, is beyond or "post" human.

#### **6.4 Conclusion: Towards the Post-Human, Stelarc the Cyborg**

Consider the Internet structured so that it would scan, select and switch-automatically interfacing clusters of on-line bodies in real-time [...]

Imagine a body that is open and aware, invaded, augmented and with extended operation. Consider a body whose awareness is extruded by surrogate robots in situations and spaces where no body can go [...]

Perhaps what it means to be human is about not retaining our humanity. (Maria Grzanic, 2002, pp. 20–21)



Kathryn Hayles (1999) describes the post-human as slowly adopted relations which 1) privilege information over matter or body in terms of how technology operates in our lives, 2) locate consciousness as a “minor sideshow” in human evolution, 3) consider the body an “original prosthesis” that can be discarded for new prostheses, and 4) configure humans so that they integrate seamlessly into intelligent machines. Hayles suggests that these post-human conditions came about as soon as we began to consider the possibility of physical existence in separate cultural, psychological and technological domains.

This separation or redistribution of the self into different dimensionalities, using technology, has brought with it the sense that human beings do not need to be constrained by biological evolution. The performance artist Stelarc, for example, argues that perpetuating the human species by male-female reproductive intercourse is not the best way to approach a new post-evolutionary philosophy and physiology. He claims that 1) the body is “obsolete” and 2) it is an “absent” entity that “performs” in a world in which physicality is “receding”.<sup>12</sup> He also believes that we are on a hopeless mission to save something that is beyond hope. One of Stelarc’s main arguments is that the body is just one aspect of a complex environment influenced partly by ecological concerns and partly by biologically necessary operations. He claims that it derives its intelligence from complex interrelations that take place between all of these systems rather than any wilful set of actions on our part. He also asserts that this body needs the help of technology because it is ill equipped to survive in a future post-human environment. According to him, the body is merely a “host for multiple agencies” and “intelligent avatars”. His intention, therefore, is to help evolution, which he presumes is blind and/or uninterested.

It is questionable how much of Stelarc’s performance histrionics, with his electronic Third Arm, for example, enhance the body’s ability to articulate itself meaningfully. His international performances of “Events for Amplified Body, Laser Eyes, Automated Arm, Third Hand and Video Shadow” (Stelarc, 1990) are spectacles of technology reminiscent of those shown in Europe at the height of the Industrial Revolution (Marek, 1965). Many of these latter events were designed to entertain people. Laser beams projected from the artist’s head is also reminiscent of popular Hollywood movies like James Cameron’s *The Terminator* and *Terminator 2* (1984, 1991). Stelarc’s body is wired with electrodes that monitor its vital functions, and the

signals are amplified to produce a complex sound environment. Currents of electricity manipulate both the artist's arms, one of which has a third hand attached. This figure is positioned within an interactive grid of light bulbs on steel rods with rocks and wooden pallets. The body is thus probed and turned inside out with a simulacrum of its functions projected into space. What lies behind this display might be pure mischief, but even if it is, the work is still worthy of serious reflection.

Stelarc confidently promotes this extreme notion of the post-human, one that is no doubt conditioned by his earlier work. In this earlier work,<sup>13</sup> his body went through a process of desensitization by being hung, pierced, stretched, probed and generally subjected to extremely painful processes. This ability to condition oneself to withstand pain or to divert it, very much like a Hindu yogi or fakir might, influences his philosophy of the absent body. A body that is absent feels no pain; in fact, pain does not exist in such an individual's sphere of consciousness. This means that either that person is incapable of feeling pain, i.e., has no knowledge of it in that state, or is able to assimilate and transcend such pain in an act of true transcendence.

Which category Stelarc belongs to is open to debate. However, Stelarc's definition of the post-human results from a decision he made concerning the dilemma of desensitization versus transcendence. That decision has led him to confidently promote machine-like and cyborg-like transformations as a performer and to claim that he is in fact augmenting deficiencies of the human body. Stelarc speaks not of an "I" but only of "the" body; he speaks confidently about what he sees as an "absent" and "obsolete" organism that needs a new "evolutionary strategy" to survive or at best cope with the world created by rapidly developing technological innovation. He claims that the old "Aristotelian impulse" to accumulate ever more information has created a situation in which the human cortex is incapable of consciously processing it, arguing further for the necessity to create new technologies that can assume responsibility for activities our bodies can no longer handle.

I believe we should be concerned when someone like Stelarc says that we have "created the potential of life without humanity". Does he mean that "humanity" is a negative concept in a post-human society or that our concern for the "human" prevents us from achieving a new evolutionary stage of development? Whatever the case, his claim that the best strategy would be for us to stimulate a new "evolutionary dialectic"



that incorporates technology into the body, “symbiotically attached and implanted” as a “human hybrid”, is extremely provocative.<sup>14</sup>

I must confess that, after viewing his performances and co-conducting an extensive interview with him,<sup>15</sup> I had a much better understanding of his work than I got from reading the available material. In fact, it would have been impossible for me to imagine the scope of his influence without these experiences. However, this did not eliminate my serious concerns with Stelarc’s approach. The argument that I am raising here is that any discussion of post-humanity should first consider understanding the role that human beings play in the larger scheme of things, a role that, in my opinion, Stelarc ignores.

If, as I argue, Stelarc has become desensitized in the course of his activities and is seeking ever new forms of stimulation, his performances capitalize on desensitization rather than attempt to stimulate a new evolutionary dialectic, as he claims. I argue that, to achieve a state of post-humanity as part of an evolutionary dialectic, a different strategy is needed. As I mentioned earlier, any discussion of post-humanity should first consider understanding the role that human beings play within the larger scheme of things. The role I have been suggesting all along locates the human being among all other sentient beings in a process of mutual and reciprocal “feeding”. By this, I mean that human beings exist to increase awareness in the world and that, as Kwakiutl philosophy and its cosmology affirms, we provide “food” for a higher state that we are capable of achieving within a larger system than we now imagine. This is not just a figurative way of speaking: if impressions are indeed sources of nourishment, the process of assimilating and transmuting them is a crucial part of our evolutionary perspective.

To speak of the post-human is to assume that we have experienced the entire range of what being human means and that we are already in the process of being transformed by that experience into something else. Stelarc may have found ways of enduring or shunting pain he would normally feel when hung by his skin with hooks of one sort or another. However, avoiding or shutting out physical pain is not necessarily a mode of transformation or even transmutation (James, 1982). I do not mean to minimise Stelarc’s work as acts of performance but rather to locate it within a particular technological realm. He has adopted a relationship to sentience in his body practices

that allows him to progress seamlessly from grappling hooks to invasive medical devices without any form of anaesthetic. The question here is whether he has taken an evolutionary step forward for himself or merely helped someone develop a smarter technology, in which case it is the technology that has “evolved”. If becoming a human being, in a Darwinian sense, means descending from the apes, then a post-human existence should be “above” the current species in intelligence and awareness. In my opinion, Stelarc, and others who claim that human beings are taking evolutionary steps forward in our development of the cyborg, are correct in a negative sort of way. It is the cyborg that is evolving and at the same time challenging human beings to do the same. Whether we are rising to the challenge is the more relevant question to my mind. New technologies will help us to evolve only insofar as they provide a platform for leaping into another realm of experience. Unless we adopt such a perspective, we will merely repeat the old “colonialist” habit of attempting to populate a newly discovered territory with the same old fears and preconceptions. A definition of the post-human that requires entities to exist in environments that are purely informational, or to take form in non carbon-based bodies, would arguably have many excellent uses. However, like Mary Shelley’s *Frankenstein*,<sup>16</sup> we have no way of knowing what these entities will do.

Stelarc’s work is nevertheless useful in demonstrating the challenges we face at the intersection of machine and human activities. These practices also establish an interesting context for transdisciplinary studies, since they involve disciplinary practices and discursive directions that converge, through technology, on the human body in performance. Stelarc’s early work involved body suspensions, sensory deprivation and skin piercing, from which he graduated to using medical and industrial machines/robots. His signature is the exploration of both the inside and outside of the body as flesh, data and cybernetic device. This approach allows him to use highly scientific and technological equipment, supposedly to concentrate on artistic, philosophical, moral and ethical issues. Although I have grave reservations about both these directions, at least in the way that he and his colleagues conduct them, I do believe these are preliminary explorations, and like all preliminary explorations, they will eventually give way to more serious investigations.

The interview with Stelarc in the following chapter reveals interesting perspectives on the artist and his work. Here is an individual who maintains an extremely tight hold on



a body of work that was at first centred around his physical form but subsequently developed into a fascinating study of a variety of sophisticated electronic and robotic machinery requiring a great deal of specialist expertise. Stelarc has built up an air of mastery in performance that enables him to both deny and assert his importance. Looking at his work, one sees an individual who claims to be absent but who is present to his audiences and to the administrative, academic and funding bodies that generously support him. His approach supports my argument that it is no longer sufficient to look solely at inter- and multi-disciplinarity among the arts, humanities and sciences. One needs to look at the new possibilities that transdisciplinarity suggests. We can no longer isolate the issue of technological development from the wider implications of social, cultural, political and economic change. Nor can we, as artists, deny our important role in negotiating the machine-human or computer-human interface.

As I mentioned earlier in this document, I am concerned with a particular notion of the “lived” experience that exists at the genetic level of being, one predicated on the fact that we inherit the memory of life’s evolutionary processes as part of our human biology. As such, we can re-live this memory in a conscious manner through the medium of performance. While science and technology are more concerned with a type of performance that relies on the efficient operation of mechanical and/or technological systems and prototypes in specific goal-oriented tasks, human performance includes the will and ability to act in a conscious re-cognitive mode. My argument has, therefore, been steadfast in its claim that we need to probe more deeply into the nature of embodied experience in order to balance contemporary society’s growing technologization. This means that a more in-depth exploration of self can help us deal with the shifting territory of the machine-human and/or computer-human interface. I argue that, if the intention of the cyborg is to help us overcome pain, suffering and death, then a built-in denial of self underlies technology.

The artist Stelarc claims that his work is stimulated by the excitement of exploring the physical and psychological limitations of the body. However, it is important to keep in mind that these same physical and psychological limitations provide the material from which new evolutionary directions arise. The interview in the following chapter was conducted with the intention of finding out the extent to which new artistic works, existing in dynamic, interactive and experiential environments, could be preserved for

future reference and research. In other words, we were questioning how the new cultural products of our digital age could be saved for future generations in the extended memories of new electronic archives. Stelarc's response was simply that we should preserve his body. He may have said this in jest, but the fact is that the human race has an in-built survival mechanism that preserves the memory of its actions by continually making copies of itself in new individuals. Stelarc attempts to experience the Internet as part of a larger sentient environment by treating it as a "crude external nervous system" and as a place where the body's awareness extends beyond its physical limits. This is an idea that reveals his work in a more constructive light. In his opinion, this perspective is devoted to enhancing the body's abilities through new "technological additions" and "genetic" interventions. The aim is, therefore, to achieve a different evolutionary future than the one we would inherit if "natural" processes were to continue unaided.

However, I fundamentally disagree with the claims that he makes about this perspective. Instead, I argue that the body is present, and its physicality is receding only insofar as we deny corporeal being, i.e., the wealth of "lived" experiences that form part of our genetic past and that we can build on for the future. My position is that, as technology continues to develop exponentially, it will become even more important for us to develop new techniques to affirm the "presence" of the human body. This way, we may never have to wake up like Neo in the *Matrix* (1999), the *Matrix Reloaded* (2003) and *Matrix Revolutions* (2003) to discover that artificial intelligence has imprisoned humanity in a virtual world.



## Chapter VII

### Archiving Memory: Techno-Spiritual Bodies and Radical Performance Art

#### 7.1 An Interview with Performance Artist Stelarc (Duranti & Daniel, 2002)<sup>1</sup>

Conducted by:

L: Luciana Duranti & H: Henry Daniel with the performance artist S: Stelarc on June 2, 2002 at the Crowne Plaza Hotel, 801 West Georgia Street, Vancouver, BC.

S: I guess what I do is called performance art; I'm an artist using new kinds of technologies for expressing different ... I guess expressing different explorations of the human body. And I think mediums like virtual reality systems, the Internet, robotics ... all of these are used in these performances.

L: I keep recording his laughter.

S: (showing images of his performances) Yes, I have a robotic third hand where I've done these different writing performances. The extra ear project, constructing an ear for the side of my head made of my skin and cartilage. Yeah, this performance is one in which the body is amplified in terms of its body signals. Laser eyes, and its left arm are involuntarily moving through muscle stimulation; it's computer controlled. I did a series of Internet performances where the body is actuated by Internet data, a series of suspension performances hanging from my skin — this is from over East Eleventh Street in New York. I got arrested for this one, for being a danger to the public. The nudity wasn't a problem but ... (laughter). So here I was in Luxembourg, people in the Pompidou Centre in Paris, the media lab in Helsinki, there was a perception conference in Amsterdam. People in those places were able through a touch screen interface to remotely choreograph my body in Luxembourg. So someone in Paris was able to program the body and a second later my physical body moved involuntarily through voltage delivered through electrodes to my skin. I've also done performances with industrial robot arms. This was a remote-controlled performance. I was in Yokohama, my third hand attached to a Japanese artist in Tokyo, in a Tokyo gallery. So I was able to remote control my mechanical hand attached to another person in another place. This is in Copenhagen, sixty metres up, suspended using a large crane. Again, some amplified body performances. This indicates how the third hand is attached. It is controlled by muscle signals. Six-legged walking robot. So, in this case the robot moves to my arm gestures. So, by making different arm gestures the robot moves with different leg motions. Some more suspension performances. Different positions in varying locations. Running through a sheet of glass in Mexico City. Suspended from a tree in Australia. This is an object, which is actually an electronic capsule,

which was inserted inside my body, so, a sculpture not for a public space but for a private physical space. Another performance with laser eyes. Again an Internet performance where the Internet becomes a kind of crude external nervous system for the body, so the body is optically stimulated and electrically activated by Internet images. Some more suspension performances.

L: Why all these suspensions? What does suspension have to do with being able to ...?

S: Well these, these go back a long time, but there is information on the back of them. So I mean, I guess this was a series of performances that explored the physical and psychological limitations of the body, and then the...this is another shot of the walking robot.

H: I don't have all of these; you have to give me one. I'm going to put this into my archive.

L: Thank you.

S: You're welcome. And you don't mind if I ...?

L: No I don't.

H: I think your question is very good Luciana. It's one of the reasons I was so happy Stelarc was going to be here. Because you have no idea of this kind of performance, I think the questions you ask are very pertinent...they come from that place of curiosity, you want to know.

L: Well, I have to try and understand what the activity is and what the product is intended to be.

H: Yes.

S: So in the visual arts there is what we call an area called performance art. And performance art uses the body itself as a medium of expression, and also I'm interested in technology extending the capabilities of the body, so it's this combination of the body as performance and technology providing the means by which you can extend the general capabilities of the body. It's not dance in the traditional sense at all, although I do sometimes get invited to dance festivals because there's an interest in, especially the involuntary body movements. So, in other words, you can programme a half of your body to move involuntarily, then the other half can collaborate with local agency.

L: So, what is the product? Out of all of this, what it is that you intend to achieve. Other than testing to see how far you can go, at the end of this activity you have got something that you can show for what you have done, right? And what is the something?

S: I have some performance postcards.

L: Ok.

S: Ok. I have some videotapes.

L: So you just show what the body can be pushed to do in an artistic way.

H: But it's a performance.

S: Yeah, in an artistic way.

H: I think one of the things that is very interesting, one of the questions I would ask, provocatively of Stelarc would be, why do you call



your performances dance? Why do you use the word choreography? You just said, "It's not dance as such, it's performance art".

Now...what's happened within the field of dance, it has expanded so much — you have the traditional kind of dance performance where there is a piece of choreography, you make up a set of steps, you give these to the dancers, they perform the steps, and you have a piece that you present on stage. In lots of these kinds of dances the body is taken simply as an instrument for choreographic craft. Now dance research has made the body a site for a discourse. So now the discourses that are happening with this body...we have different kinds of issues about gender and culture, for example, questions like which body is performing, what kind of body, whose body? Is it a racialized or sexualized body? Performance art came out of a lot of interdisciplinary studies with visual art, so you find now a lot of visual artists doing performances based on the body, almost like a form of exhibit. So the body is a site, like a canvas.

L: Yes, but he is, ok ... so, whatever you are achieving is comparable to a painting or a script? So, is it something that is there and that's your purpose and it is you and it is what you have done, or it is something that somebody else will repeat or will use?

S: I think people would be very foolish to try to repeat some of these performances.

L: Ok. So in fact, it is more like a painting. It is more like a work of art that you do.

S: Well it's a work of art, but it's, in other words, what we call performance in the visual arts is not performance in the dance sense or in the theatrical sense. Often these performances are one-off situations. They are in a sense more unique actions, and although sometimes I might repeat a performance, it's not in the same sense of doing another performance of a theatrical piece, or a choreographed dance piece that can be repeated over the years.

L: Yes ok, so this is important for us to determine what it is that is important for you to preserve of what you have done.

S: Well, of course it's the kind of conceptual *raison d'être*, and the sort of visual aesthetics that are in a sense expressed and documented. So as you've made clear the body becomes sort of a site for discourse, and so these performances generate certain questions about the cyborg body. What it means to have a body. What it means to talk about a mind. Is it meaningful any more to maintain the integrity of the human form, as we know it biologically? Can we redesign the human body with technological additions or genetic interventions? These are some of the issues and questions that come out. But, of course, from an artistic point of view, what's left over is a videotape recording, or a series of images, in a sense that prompt the performance just as a dance performance or a theatrical performance can be prompted by its visual documentation.

H: But you have software, hardware, data that go into every single one of these performances. No matter how you changed it there are certain prerequisites that you need to set up for that performance and these things in a sense, they're objects, they are records. Now if no

one else is going to do these performances but you, in a sense no one has to reproduce it exactly. But if you, for example, want to repeat a performance you did ten years ago, you have to have every one of those objects specifically as they were made or set up to repeat the performance. Or let's say you've put them in a collection, or somebody wants to do a research project.

L: In addition to that, if anyone wants to understand your work, really, wouldn't need to see actually how that arm is constructed. What all the steps were through which you went to conceive all of that apparatus that you have conceived. So wouldn't it be important in order to understand your work and in a sense to take advantage of it in understanding the human body, what it can do. Would it be necessary to go through all your process of creation and try to understand it?

S: I think that's fair enough; it's a fair enough assumption. I was talking before you came about the fact that as a younger artist you might methodically collect every little bit of information, every drawing every, you know. Whereas as a more mature artist you focus more on the final result, and often you don't keep these little ... you know, I certainly don't methodically keep all of these records. On the other hand, as you said, there is software, there is hardware, there is visual documentation that would help to reconstruct a performance, although I would be highly unlikely to repeat something I did.

L: But let's say if you were unhappy with your performance and you wanted to go back and change something from a certain point, you still would need to have all the material.

S: Yeah, but again that's not often how an artist works. You make jumps. You make intuitive leaps. You formulate a performance through the actual physical testing, rather than sort of methodically following through a blueprint and also documenting rigorously what you've done. I never document rigorously what I've done, partly because I think this has been an obsession that doesn't really indicate much at all.

L: No, you shouldn't document what you don't need to document and you shouldn't keep what you don't need to keep. It's up to the next generation to try and save that. But, then, what is it that you need to have? What is it if you could you would like to have? Just the final video? Just the final pictures?

S: To be honest, that's my recent sort of thinking, is more and more focussed on the end product rather than the process. I know that, especially in the later twentieth-century art the process is seen as being a very important aspect. In fact you don't separate the process from the piece. I mean like a Merce Cunningham and John Cage collaboration, in a sense everyone's doing their own thing and often things in a sense intuitively occur. The process becomes the performance in a way. Whereas I guess I don't necessarily think that way myself, although there are aspects of a performance, say with an Internet performance. There is software necessary. There is specific hardware necessary. There is certain interface connections



constructed. There's my third hand. There's a collaborative team sometimes of two or three programmers. So all of that constitutes what finally becomes the performance.

L: So it is in fact an integral part of the performance.

S: It is, yes.

L: So you would want to have it?

S: Well yes, but one of the problems with digital media is that it's not always difficult, or it's always easy to preserve everything in a way that ...

L: That's why we're there.

H: We're coming to her bit now.

L: That's right, we're coming to save the world. That's the entire purpose of InterPARES: is to find a solution to the permanent preservation of authentic material throughout obsolescence.

H: We should talk about authenticity.

L: Well, an authentic document is what it says it is. Something that is not tampered with, has not been tampered with, or has been corrupted by the technology or by any malicious intervention, and you can prove it.

S: Especially by other artists.

L: Exactly. By malicious intervention, that's what I meant. So because our purpose is to determine methodologies for actually being able to preserve all of this and also to issue guidelines for artists on what to do with their material in order to be able to preserve them, we need to understand what that process of creation is and what the artist regards as something that needs to be preserved, and what are the problems presented by the preservation? Is it just technological obsolescence, or are there other issues related to that specific material that you are generating?

S: Well for example, my early performances are documented on open reel black and white videotape, which I can no longer see. I don't even know the condition of these original tapes because I can't play them anymore. It's not to say that it's impossible to, but I would have to find really some special studio or archival space that has these very old ... or to somehow keep updating this digital media into the very latest. For example, I recently put a lot of my video clips on DVD. Not only because it's a more convenient medium; I don't have to carry a box of VHS tapes with me now. I just have a disc. But also, that some of these video recordings will be difficult to see in a few years unless I keep updating to the next, the most contemporary medium.

L: That's right.

H: These are some of the issues that we are dealing with.

L: So basically, the standard questions that we have here are, well you answered in a way. The first one is very hard to answer because you have different activities. The first is "describe the steps through which each activity is conducted". So what you do, what you go through. Then the second question is "what types of documents are generated at each step?" Then, "which of these documents do you want to keep?"

H: Should I give him a copy of this then?

L: You can give him a copy and he can just try and address them in the order in which he feels he would like to. You said you don't preserve those records for the purpose of re-enacting the performance. So why do you keep them?

S: In many cases I don't.

L: You don't?

S: Let's say you're dealing with very special problems. For example, a lot of my written exchanges are now done in e-mail, or they have been done in the last ten years in e-mails, and so this stuff isn't filed away. Computers have been replaced; some of that information is no longer in any of my more recent hard drives. Say the last three or four years I might be able to retrieve it.

H: These are e-mails you are talking about now?

S: Yeah.

L: So you have not filed them or organized them or saved them? Saved it to disc?

H: These are the e-mails you are talking about?

L: The e-mail.

S: As I said, the last three or four years is still on my computer. When I reach the limits of my hard drive I might have to erase some of this stuff just to make more memory. Also, because I haven't printed out all of these records there's no sort of traditional filing, and therefore organizations or libraries may not have easy access. I think before widespread digital media use there were three or four hundred years of archival practices based on paper files, based on media that were fairly constant. The problem is the last sort of fifty years' media have been so rapidly changing that information and records are lost through either records not being transcribed to new media or else just simply playback machines becoming obsolete. I mean I have lots of ... as a younger artist I did keep my sketchbooks, and I have notes and drawings, but that's in the more traditional way of working. But in recent years that's not been the case. As I said, I would have to make an extraordinary effort as an artist to keep updating my digital media. Generally speaking, you accept the fact more and more that some records get lost in the transference.

H: I have a couple of questions for you. You wouldn't repeat those original works, or would you? Would you re-stage them?

S: No.

H: You wouldn't. And would you consent to anybody performing them? I'm just saying that to raise the hypothetical question of what would happen if someone said, "I really would like to do this performance that you staged twenty years ago because in the history of digital performance art this has been an absolutely crucial work and I would like to repeat that work", and they ask you for permission to do it. Would you allow that?

S: Well it's an interesting question.

H: Because I guess I'd like to address problems of how to reconstruct that work? From what?



S: Yes, well I think the *raison d'être* for reconstructing works is changing, and also because performance art, my particular field, is not performative in the sense that theatre or dance is, then you don't get that kind of question coming up. On the other hand, in a sense it's a conceptual gesture that you make. For example, your body being actuated and choreographed by Internet information. In a sense, the concept, assumes a greater importance than the actual performative aspect or realization of it. It's a question that I've never really been asked before because I don't ... It's like; there's a famous Chris Burden piece. Chris Burden was sort of one of the early American performance artists, right, in the early 70s, who for one of his performances had himself shot in the arm. Now that's a sort of extreme example, but who would want to reconstruct such a performance, or what is the *raison d'être* for reconstructing such a performance, and similarly with a lot of my performances. But having said that, there is a six-legged walking robot, a machine that would be able to be activated by someone. There is a third hand that was in the gallery exhibition here at the Vancouver Art Gallery that in a sense authenticates the performance. Here's the object. In a sense, that authenticates the performance. The performance really did occur, and this is the object through which the performance was expressed. So as well as video documentation, descriptive technical documentation, for example, I have notes when this hand was first constructed, and the process of building it and what the problems were. The first time I made this third hand I actually made a cardboard mock-up of it to see...how does this look, what the proportions are like. So there are those sorts of bits and pieces left over.

H: They are in your care?

S: Yes, more or less in my care. In other words, they're sort of stuck in a cupboard somewhere. No museum has offered to collect them.

H: I think one of the reasons I'm asking this, I'm leading to something. The digital archive at Nottingham Trent University for example, where Stelarc is a research fellow, has what they call a digital performance archive. But that's not an archive in the sense of how archivists think of an archive. That's more like a database of performances, videos, CDs, tapes or CD ROMs...digital memory. The people at Nottingham Trent collect these artefacts. Now, at the New York Performing Arts Library they have collections that are real archives. They might have the Isadora Duncan Collection, or the José Limón Collection. Different objects, not necessarily tapes but whatever media they had at that time.

L: The by-product of their activity, whatever that was.

H: I think these are closer to ...

L: That's archives. That's archives of an individual. Archives of individuals are always fragmented with respect to the archives of an organization.

H: Now these have only been collected there because maybe José or somebody else donated them to the library at one point because that was the only way they were going to be saved. Now, there are very

few of these collections that actually are in public spaces. Some of them are in different private spaces, private collections.

Now the people who use these archives are researchers who might probably be writing a book, or maybe dancers who want to re-stage one of the early pieces...maybe a historical performance, a performer may want to re-stage this piece exactly. In the ballet now, there is someone notating as the choreographer works. A reliable record is immediately available in written form. What Stelarc is doing is innovative for several reasons...for a starter there are no steps to notate. So on one hand you have the steps, which are important for dance, and on the other hand you have electronic systems, which are important for interactive environments. The artistic record in the second instance is the entire system really.

L: But that's why they are so much more important than the others.

H: Oh, of course. But a lot of these artists are not interested in preserving these environments ...

L: You see the interesting thing is that with traditional materials, the artist didn't need to be interested. If the artist didn't care about destroying something, making the effort to destroy something, the stuff was there. Now, if you just forget to make an effort to preserve it, it's gone. But also, this is a disadvantage to preservation, but there is an advantage, and it is that the material becomes inaccessible so fast that it could be in the time the artist still wants it. So actually, the artist will make an effort because of his own needs, not because posterity may need it.

S: Short-term need, yes, ok, I get you.

L: So that's in fact what we are trying to address in the first domain. What we are trying, our research is to try and address the needs of the artists for carrying on their activity, for maintaining the record of what they have done for their own purposes.

H: So maybe we should ask him that question now.

L: Exactly. That's why the question goes back: what it is that you really would like to keep, would like to preserve. So what we should focus our efforts on.

S: Well, for example, whereas before I kept sketchbooks and notes, what I keep now is a website, and my website is in a sense a collection of what I think are interesting documentations: records, notes. So, for example, the set of those postcards are on my website. You can see the front and the back view of the postcards. You can see the image and then you can see the information on the back.

H: There are videos there as well, right?

S: Yes, there's a few little videos. There are some animations. There are some demonstrations of some of the software like parasite, for example. There's some text, some articles that I've written. There's also in a sense an archive of some of the different images of the performances. So in a way the website indicates the kinds of products of the performances that I do.

L: That you attach value to.

S: Yeah. So in a sense the archives, the website becomes a kind of public archive. But also, more importantly for the artist, a means by



which he can organize his kind of artistic life really. I mean there are my biographical notes, there's my ... and of course the advantage of the website from the artist's point of view: I don't have to carry anything. I can come to Vancouver and say, "Ok download all of this stuff", and then I walk out of the office and I can walk into the gallery and give you a set of my documentation. But the website is more than just simply a kind of visual gallery documenting my work. It's really a record of my thoughts. Some examples of software. Much like I used to keep sketchbooks, now I keep a website.

L: And you threw away your sketchbooks?

S: Well I have some of the earlier.

H: I was just bugging him about that one. I said. "I'm coming to Australia to get them from you".

S: He just wants to visit Australia. The Italian community in Melbourne is really very good, and you'll get no better Italian coffee or pasta than in Carlton in Melbourne.

L: I think I've been there. I think that's where they took me when I was there.

S: So you know it well.

L: I don't know it well because I was in Melbourne maybe ten days, but they took me around a lot, particularly in the Italian places because they wanted to show me that it was not so far away from Italy as it appears.

S: But, for example, the one thing recently that I thought of somehow preserving was... I worked on a project which involves developing some special software for a performance and there were three programmers and me communicating and collaborating in this software, and we had an extended e-mail exchange ranging from general concerns to really technical specifications to some, actually, to some examples of software and stuff like that. Something like that, yes, I did think at one point, "Hey, this might be really interesting to preserve." Now it's still on my computer, but I haven't taken any steps other than to....

L: I have this idea that from what I have understood of your work. Although it is primarily artistic, it is also aimed at development of knowledge in a way because you are trying to look at, to understand better what you can do with a human body and how you can challenge it in specific situations. So in a sense it is building knowledge, and it is knowledge that you don't want to be lost because you want to be able to build on it rather than starting over every time. So there is a way in which the preservation of this material in its environment, as you were saying, its technological environment is essential to understand the state of knowledge of your body at some point, and how it grows.

H: I would agree because we haven't spoken much about ... Stelarc does these performances and he does these talk-about or talk-throughs where he explains he has a very strong conceptual basis he does his work from, and one of them is the idea of the obsolete body or the absent body. It extends the whole idea of phenomenological

philosophy. And it's very interesting that his work has gone from extending himself by hooks in a yogic state, where in a way, the physical body has to be absent for you to be able to hang there, or else you would probably die from the pain. So he has been able to create another conceptual space where there is no physical body, as we know it. So, phenomenologically, he's dealing with the concepts of absent and obsolete bodies.

L: That brings me to, in a sense, an absurdity from our point of view. Because from our point of view, to preserve something which has been born digital, you need to update it all the time. However, the knowledge that we need is what was at the time. It's not content in an updated form. We want the old form because what we want to understand is: What was the technological environment in that performance? If we keep migrating it and updating it, it's not any longer the environment of that performance. It is a new technological environment for an old performance. So in fact what we are doing, we are not preserving the authenticity of the record, we are altering it.

S: The other problem, too, is that often software is hardware specific. ... you write software for a particular computer.

L: A legacy system, proprietary.

S: The hardware and the software are often coupled. I can't, for example, reproduce some of the Internet software without having a Mac 8500 to play it on, and now where would you find a Mac 8500? It's a big problem. So, unless I had in my home a collection of different computer architectures, being able to play specific software programs that were written for them, then these things do get sort of lost or put aside. One of the major projects I did was my virtual arm project, and probably all that software now has been lost, because it was done at the Advanced Computer Graphics Centre, which no longer exists, and it was software written for Silicon Graphics Onyx Reality Engine. It wasn't something that I could just simply take away, and even if I did take it away I could never use it. So effectively it was sort of left there, but then with the Advanced Computer Graphics Centre closing down, systems being dismantled, it's probably lost altogether. What does exist is some video documentation, which indicated some of the capabilities of this virtual arm. I'm actually doing a project now, which is an interesting one in terms of documenting ideas. We're now constructing a 3D computer head that resembles my head, and this head will have a database and an Artificial Intelligence Engine with facial expressions. And this head, which looks like my head, will be able to respond to the person who interrogates it. So it means that, like I've been increasingly busy over the years...

L: We can interview your head?

S: Yeah, you could interview my head instead. It's really funny. I get all of these...I set up a website because in a way there was a demand to access some of my material. But, the more I put on my website, the more it generates interest and the necessity for people to be doing personal interviews with me. Now I'll be able to say to



those pesky Ph.D. students, "I'm really too busy to talk to you, but if you want you can talk to my head". And the head will have a much more reliable retrieval of information; it won't be able to forget things like I do.

L: It would be consistent.

S: It would be consistent. It won't be gender biased. It will be a philosophical head rather than a flirting head, which is usually what's attached to my body. Also, through speech recognition, I will be able to talk to my own head and it will be able to respond to me.

L: That means all the advantages are gone, right?

S: And I'll always be a step ahead. But the interesting thing is you also have facial expressions mapped. So, for example, with an Artificial Intelligence Engine the head can interpolate what is meant and also your attitude. So if you are aggressive to my head, for example, if you sort of say to my head at first, "You stupid head" the first expression of my head might be surprise. And then, if you persist in being aggressive you might say, "You really are stupid aren't you?" And then the head might say, "Do you really think I'm stupid?" And if you still persist and keep calling me stupid, then the head might finally respond, "Well up yours too".

H: There is something Luciana said earlier that I was thinking about...

L: I think this is very interesting, and the reason it is interesting is it goes against all the grain of preservation of digital records, because preservation of digital records practically aims for preservation of content, changing form, adjusting it to the technology as it comes out. But the key to your art is form not content. If we change the form not preserving the content, we are not preserving anything. And so we might be in that unique situation in which we don't need migration as a solution. We need simulation of something that has become obsolete in order to reconstruct the environment exactly as it was rather than updating it.

H: What you seem to imply by that question, I thought at one point you are actually preventing the furthering of that specific form of knowledge.

L: By keep moving the things through the technology rather than keeping ...

S: But that's an excellent observation because in a sense if you create conditions in which you can simulate the performance, then there's really no necessity to try and use old outdated software. There could be some interest nonetheless, but as a performance artist; I would only be interested in the final result. Whether you find an old 8500 Mac computer and play the software on that or whether in a sense you generate a simulation of that software in a new medium and be able to replicate or mimic or whatever, then I think that's satisfactory. I would go along with that. Of course, I think too, the difference between the copy and the original, or the real and the simulated becomes more and more blurred. Before there seemed to be very real distinctions, but there aren't really any more.

L: Well with digital material you don't have any more the original. You lose it the first time you save it. So at that point, you have to

see what is the closest thing to the original, and so what you can call a copy in the form of an original. And in your case, it would be much more appropriate to protect form by keeping the material exactly as it is and, when needed, using a simulator to make it function, then transform it in an environment which is a modern environment. But then you wouldn't be able to justify why the performance was so limited. If you had these other possibilities, if you had this technology as it is now, why does you body only do that instead of something else? You have no more reason. But if you have exactly what you had before then you understand because it is its own environment.

H: How is that different, for example, maybe to governmental records or some of the other records you deal with?

L: The difference is that with government records the most important thing you need to preserve is the content, is the speech. It's not what it looks like, it's not what it shows, it's what it says.

H: Is that because it's text based?

L: Well primarily, yes. But even when it is not text based, even if it is images based, what you try to preserve is not the movements of the body really, or what allowed those movements to be projected that way. What you are trying to preserve is the message that is given. It's a different thing; it's really different, even from digital music I would say, because with digital music you still try to preserve the sound exactly as it sounded. And you can make it sound any way with new technology, even better than it ever sounded. It's like you play Mozart now with a piano rather than with a harpsichord. And it is still Mozart and it is still fine. You only need to know that it used to be played with a harpsichord, but it doesn't alter what the music is all about. In this case of the performance, it does alter the performance. If the body does certain things, it does them that way because that was the technology that was used at that time.

S: The issue with me is not to preserve the artwork, but to preserve the body itself (laughter).

L: Which from the pictures looks a bit challenging.

H: I have a question. If, for example, the exoskeleton, or maybe not that one ... I was thinking about the demonstration you did with the third arm. In this third arm he feeds a set of electrical impulses into the arm, and I put the arm on you, for example. The way he feeds the electrical impulses, you begin to move the arm in very strange places. So in a sense no matter whose body it's on, those same electrical impulses will produce the exact same choreography. Isn't that in that sense equivalent to a movement score that preserves the exact movements?

L: It is with the difference that it's that specific technology that does it. If you update the technology, would it do the same thing?

H: I'm talking about the electrical impulses. If you can find some way of getting that same electrical impulse through ... well, but it wouldn't be authentic.

L: Yes, but it might be what he wants to achieve is just the broadest form by the technology he has available.



H: So that then, that's authenticity?  
L: Yeah, in a way it is.  
H: It has to be connected to the specific hardware and software.  
L: It's like in music the people who say that you don't have an authentic performance if you don't use the instruments of that exact year. Now there are others who say that if Mozart had available the instruments of today he would have used them, so that's the way it would sound. But still, it's not what he was hearing.  
H: And we can't make that choice for him.  
L: No.  
S: No. I mean, I think you are right. I mean there are different issues and different goals in some of these recreations or performances so... I saw a ... the Gutai group, a famous Japanese performance art group, and there was a performance recreated where a person did a performance that he had done many years before, but it was a strange sort of situation because it was a kind of recreation, but it was not done in a sense in the zeitgeist, in the spirit of the time.  
H: It wasn't authentic.  
S: Well, in a sense it was a kind of gesture that tried to recreate an earlier performance. And I don't think you can do that in an authentic way. You can do it in a way as a means of...somewhat recreating, but what is learned from this recreation is very little I think.  
H: Actually, talk some more about that because we would like to ask what your ideas of authenticity are.  
L: Well the thing is that the environment goes much beyond the specific technology. The environment goes up to the audience and the specific context of the place where you are. So even if you have the perfect concerto, played with exactly the precise instruments of the time, you still don't have the same room with the same people, with the same reaction, or the same feedback. So it's still a copy in the form of the original, it is never an authentic performance because it is not what it says it is. It's an authentic copy.  
H: But even your other records?  
L: Those are authentic copies, that's what you get, you get authentic copies.  
H: Authentic copies...so we can say this is an authentic copy, so for example ...  
L: If you redo it, it's an authentic copy. If you redo it as close as possible to the original, you have an authentic copy. You don't have ever the authentic record. Authentic records are his sketchbooks, is his pictures of the time, not even if transposed on the website. Transposed on the website, they are authentic copies. Although you can interpret them as his new records because he treats them in the usual and ordinary course of his business as his own primary records.  
H: Authentic copies, that's a kind of an anachronism.  
L: No, no, authentic copies is what the government does. Is when it says I have seen the original and this is just like it.  
H: I have seen the original.

- L: That's the key of it. That's what the officers declare: I have seen the original and this is just like it. You cannot declare a copy authentic if you have not seen the original.
- H: That's the catch.
- L: Absolutely. That's the catch. So in order to have an authentic record you must have either the original record or an authentic copy.
- H: But you have to verify one against the other so you must see the original.
- L: Absolutely.
- H: So where are these original sketchbooks and other records?
- S: I still do have some of my original sketchbooks, which are a kind of record of some thoughts, some drawings and diagrams. And they are in Melbourne, Australia. It's really too far to come.
- L: No the world is small.
- H: When would we be looking to ... what kind of timeline would we be looking at for this case study?
- L: The case studies must all be totally finished by December 2003.
- S: Let me tell you that I'm going to be in Australia between... I'm travelling a lot, but because I have this residence at Monash University in the next four months ... (tape is interrupted.)
- L: (tape resumes) Any declaration to make? Ok, you must be willing to compromise yourself now. I do understand that...
- S: Is it an issue of compromising, is it?
- L: The website doesn't have any restriction, right?
- S: Basically not. You can access anything on it; you can make use of anything on it. The only thing is if any images are published, I just need to give you credits for those images.
- L: Do you...what is your website? Ok, it's here. So I can look it up, that's fine. So you don't have specific methods for filing and retrieving your documents outside the website?
- S: Well, not really, because this hasn't been done methodically. I'm the sort of person who finds it not only boring, but totally, terrible to be involved in any kind of methodical filing, retrieving, or anything like this. I find it very very difficult to do these things. If I was doing that sort of stuff I'd be an accountant or I'd be...
- L: An archivist.
- S: ... or working in a library. But there are different odd written records, diagrams, drawings, sometimes mock-ups. For example, this new six-legged walking robot, the hexapod robot. We've had to develop a prototype for that robot. In fact, in another week or even in the next few days there's going to be some updated information on my website about the hexapod project, and about some of the recent performances, like the extended arm and more information about the motion prosthesis and so on, and an updated text on my extra ear project.
- L: I love that extra ear.
- S: So that's happening now. In the next few days, you'll see that update...
- H: Now you did this with the University of Nottingham Trent, Sussex University...



S: They're the two.  
H: And they must have...  
S: Well, the thing is, there will be a link from my website to ... (tape ends) ... there is more information. On my website... basically I've chosen some of the more interesting information, some of the little video clips, the general statement of intent, the conceptual *raison d'être* for doing the performance. On the NTU website there's some more drawings, there's some more diagrams, there's some sort of background stuff.  
H: Anything from Sussex?  
S: Information about the participants and the project, for example, and stuff like that.  
H: Those guys must have papers and stuff they published?  
S: Well... for example, the sort of principle of the hexapod walking machine was also a subject that a thesis was written on, So you know you can track ... I guess the hexapod project is a recent project that has been more documented in a way than others, in the sense that there was a thesis written on the general principles and on the math simulation. There were working drawings and diagrams done. There is a prototype machine built now which will probably be discarded when the actual machine is made. One of the reasons you build a prototype is to test the engineering principles in the real world.  
H: So you've been working with the prototype with the performances so far.  
S: Well, yes, we've just constructed this new robot.  
H: So the new one is finished?  
S: Well, physically constructed, but not yet properly walking. But once we do the proper testing then we will rebuild the thing. So for your archive you can have a five-foot, a five-metre diameter robot.  
H. It looks like a huge spider.  
S. And actually in the computer animation of that, do you remember that computer animation which was shown in the museum? There's this good-looking guy on the robot (laughter). No, no, I've been going to the gym every day to try to get to look like that guy because ... in our software 3D modelling package we could only produce a kind of rather muscular looking body you know, and we couldn't actually change it to fit my body, so now that's made me go to the gym to try to look a little bit more like the guy on the machine. But I keep saying that the machine, this new robot, doesn't have a computer on board. In other words, this robot doesn't, isn't intelligent in any way. The guy on the machine isn't very intelligent either, so you have an example of a non-intelligent operational system. It means it's the mechanical architecture rather than higher order computing processes that results in the locomotion. Just like an insect doesn't have a big brain, but an insect does have individual and social behaviour that is rather complex. Why is an ant's behaviour sophisticated? Because the ant lives in a complex world. So it's the interaction of the entity with its environment that generates the complexity. It's not the big brain of the ... and of

course it's the same with human beings you know, in a more sophisticated way. Our behaviour is generated through a complex interaction of the world, our social institutions, our cultural conditioning, and the language in which we communicate and so on. It's not due simply to a big brain that we have. It's not simply just an agency driven body. So that's, in effect, really the underlying principle of a lot of these performances. In a sense, of constructing extended operational systems where the body is the biological component of a larger system of functioning. So with a tape recorder, or a mobile phone, or a car; our bodies become part of a faster, more precise, more reliable retrieval system of operation. And that's really the underlying feature of these performances. So instead of perpetuating or archiving the documentation of these performances you should sort of archive the body of the artist.

L: Mummify him (extended laughter).

H: The record doesn't exist without the body.

S: That's right. You're talking to a body-artist here, so there you are. No, but isn't it, instead of keeping records of Merce Cunningham, if you could preserve Merce Cunningham, that's the perfect archival system really.

L: But is it about the behaviour of the body, as opposed to the body per se.

S: Yes, yes, but I mean of course behaviour is in the body.

L: If we mummify the body it doesn't work.

S: I'm not talking about mummifying, I'm talking about preserving it, as a living system, or constructing such a convincing 3D avatar that would be able to move and speak.

H: See this is one of the interesting things I keep coming back to. He's actually saying that our bodies are really part of a distributed consciousness, and our complexity has not only to do with this complexity. It's the environment that's lending its complexity to us. So as such it gives some of the philosophical grounds for the concept of the absent body and the obsolete body, because it's almost as if he's ...well I don't know, you can talk for yourself. I find it really interesting this kind of sense of distributed consciousness beyond your physical body, and if you are doing work like that, the concept of the record exists outside of the record making entity or what we think of the record making entity.

L: There is a very important article in archival science which is called *Context Is All*. Context is all! The meaning to anything is given by the whole environment, and if anything is out of that environment then the meaning changes.

H: How do you locate it when it starts moving into systems?

L: Exactly. That's the point.

S: And, of course, in a sense, we construct arbitrary boundaries of knowledge depending on the informational systems that generate them. So, a microscope will see the world in a particular way. A telescope will frame the world in another way, and so on. So, in a sense, we arbitrarily define the world with our instruments, with our machines.



- H: How we frame it.
- L: And what the concept of documentation has made available to us, it has made us to see the reality in bits and pieces, which are then documented...as opposed to seeing it as a flow of things, we see them as parts. Then each one becomes a document. So you are born, you have a certificate of birth. You are married; you have a certificate of marriage. It's all separate actions because we are documenting whatever we live through. But the fact is that what we have to understand in order to preserve them, that is where the meaning is. And I think that's the key, because we can't preserve the whole thing with its environment. So, we have first to understand where the meaning is, and that will tell us what part of the environment we need to preserve in order to keep the meaning going. And it seems to me that from this interview what has come out is that with performances the meaning is per-form-ance, is in the form. And the form, that's a big restraint on how to preserve this.
- H: You per-form a form.
- L: And that's primarily where the meaning is, where then the message is. It comes from the form, as opposed to specific content.
- H: I would go into that now, but I'm not sure. It is the form, but somehow it is how you perform that form, that's something else.
- L: It is how, you see. Again, it is form. It's not what. I mean in everything there is the what and the how, but it is where is the prevalent element, right? So you can have any, let's say an administrative report, as content and as a form. Now, if you keep the form, the way it looks, like the table of contents, and you eliminate the content, you don't really have anything. If you keep the content without any form, without subtitles or anything, you may get it a bit confused and un-organized, but you still have the substance of it. Because in that specific case, the substance is the message. It's not the way it is structured or the way it is shown.
- H: Not the way it is shown...I guess it's the idea of performance we are sort of at odds with here. Because we work with certain ideas of performance as the actualization of an external form, so there is something beyond the external form. What is it that you call content, we ...
- L: Well, of course. There is nothing that doesn't have content and a form. The issue is what is prevalent. How much you can afford to lose in each of those.
- H: I guess that comes back to what you were saying earlier; a lot of work in late 20th-century performance is concentrated on process. We found that was a way to eliminate some of the dichotomies between form and content.
- L: You know why? Because process by definition is the means by which content goes into the form.
- H: And somehow, this process was the actual performance. So it's just like, how do you seduce the audience into a process of getting around, and by the end of it you don't just see this, you see how you actualized it.



S: Even with this six-legged walking robot, with both six-legged walking robots, in a way you go through a process of constructing this robot and then walking with it, and there's really no great distinction between the constructing, the testing and the walking. The walking doesn't look any different from the testing. The performance is the walking, so it's not in a sense framed in any kind of theatrical kind of setting. You construct a walking robot and you walk, and this is the performance, but what we have described is actually a process, and so there's not that distinction between ... in a sense what happens with my performances really is that it's not so much a kind of a process from content to form, but rather that form and content kind of collapse into, you could call it a process, or you could call it something alternate. If process is going from content to form, in a way this is the negation of that. So you try, it's not the traditional means by which one imbues authenticity or one imbues meaning. In a sense that's not the question to ask, but rather in constructing a robot and walking with it, it's maybe no longer meaningful to see that as a process from content to form.

H: I think, I guess, where the theatrics of it does begin to come in is here, because this is the way I work and I know the way a lot of other people work: what the audience sees as that final product, if you think of it sometimes from the artist's point of view, half of it is irrelevant because it like ... Ok, I leave my house to come to your hotel, and I take Arbutus, come down West Broadway, come down Burrard. Basically, that's the form in a sense. But the theatrics of it begins when you say, "At the corner of Arbutus I encountered this asshole who didn't indicate he was going to turn, making me stand behind him for five minutes. Then he suddenly decided he was going to turn, when I believed he was going straight on... He drove me crazy in the process". A series of thought constructions went through my head... certain scenarios. In a sense, the process of going through those formations takes me through a kind of narrative process that becomes theatrical. That's where we start to distinguish between form and content. There are hundreds of ways for getting from Arbutus to Alberni, but along each one of these, at every single turn you make, there is a personal narrative that comes out. And that's where the theatre comes in.

L: I understand.

H: So in a sense it's interesting, because, for example, Merce Cunningham wasn't interested in those hundred narratives. And he was one of the people who first started working with technology in dance. He was interested in another kind of narrative and that was how the body does what it does.

S: All symbolic associations, or metaphors or ...

H: He said that kind of theatrical expression does not interest him. He wasn't interested in the kind of theatre that Martha Graham generated. He just goes through these formal movement ideas, and he finds it intricately wonderfully detailed, microscopically interesting and fascinating. But he's not interested in the "drama" that happens in between. But the difference between the two



approaches, what the audience actually sees is extremely interesting...

L: But that's, in fact, the importance of the term purposes, because it is what is your purpose when you built your arm to do whatever you do with it. Is the arm really relevant and the purpose is just to see what you would do with your hands, or is the arm relevant because the purpose is to see how the technology can control your body?

S: But, of course, you know, when you're an artist and whichever technology you're working with. In a way the conceptual *raison d'être* and the medium of expression are intricately connected, intertwined. I have a kind of a vague idea that I want to do something with the third hand, and I want it to look in a certain way, but it's not until I start constructing it, start testing it, that some of these things become clearer, or in other words, possibilities are generated. So, in a way, it's not defined as a kind of a goal or a purpose, and then a realization and then a performance. Rather, the idea develops with the medium in which you construct it, and the medium within which you construct it also determines the unfolding of the idea or the multiplicity of the possibilities that might occur. So it's very different from, say, scientific research where you identify and reductively focus on a particular direction you want to specialize in and do research on, and then you take every intricate step to do it, and there is a reason for instrumental knowledge, for practical use, for prediction. But art is not about practical use, prediction or utilitarian use. So in a sense art is about this sort of realm of contingency rather than necessity. That's why it's so different. Artists are not being kind of obscure when they umm and ahh about goals and purposes and definitions. It's just that they don't work that way. And this is a problem I think in say, even in a project like this where you want to determine and clarify and get specific information on, and in a sense do methodical research. It's a little bit more slippery to apply that to the arts.

L: But, on the other hand, the reason why we are applying ...

S: On the third hand you mean.

L: Might be the fourth. Is that there is a completely separate purpose, which is to; the reason why we are trying to apply to the arts is that the products of the arts are the first to be lost. Are the ones that are lost the most, because when we're dealing with administrative records or legal records, with industry records, there is such a strong financial interest in preserving all this stuff.

S: Well, we have to keep five years of bloody records from taxation. If I was as rigorous as keeping those with my art performances I wouldn't be able to throw things at you.

L: Exactly, that's why the civilization of the future will think that all we do is to be accountants; because that's the majority of the records that we have through the centuries. But the fact is that we are losing primarily the records of creative activities because there is no societal economic interest in preserving them. And because the artistic activity by its nature is individualistic, so it's not easily subject to rules and procedures and standard ways of doing things.



Is very difficult to get artists to follow specific standards when dealing with technology in order to preserve their own material. So, at the end of the day, we will end up not having any expression of artistic activity and just having financial records. That's why we need to spend specific attention to those matters. We need to sensitize artists to the issue, to the fact that the generations of the future will not have any sense of the advances in understanding of our own nature and our own bodies and our way of being that have taken place through the development of art.

H: With that in mind, would you consider...for example, Stelarc is saying, "He thinks I need to preserve, a lot of them are already on my website", how...

L: Up to a point, because what he has in his website is what he believes he needs now, but it's not necessarily all of your achievement.

S: No, that's true. But what's on the website is not only what's defined as what I need, but is a kind of attempt, in a way to document not only the final results, but also, there are little demonstrations, little animations, little diagrams. So, it is an attempt in a way to ... I'm using my website like I use my sketchbooks, really. It's a collection of material that not only documents but also in a way partly explains what is going on.

L: But aren't you self-censoring yourself in the website, knowing that it is a public thing?

S: Self-censoring? To a degree, yes.

L: What is the image you like to present of yourself? It's not necessarily all of yourself or of your work.

S: That's true. I guess there's a little bit of that in everything, really.

L: Which is an important record, because it is very important to understand how artists want to see themselves.

S: But, for example, in a way what is in my sketchbook is exactly that. I've torn up and thrown things away because I didn't like them. What you see in my sketchbook is what I would like you to see. So, in a way there's a little bit of...

L: So you are self-conscious in your work?

S: I think it's really difficult not to be because we don't keep every little thing that we do. Also, unless what we keep has some meaning or expressive content or visual reason, then generally it's not kept. So, as I said, the website is ... I don't know if you noticed on my website. There's a sort of a comments request by visitors. Visitors who visit the website sometimes write comments, and the comments can range from, "you crazy idiot", to... and more abusive.

L: You actually show them or you just read them yourself and?

S: The thing is my Webmaster is free to choose the most interesting ones. I don't censor him. But I was re-reading them the other day and I thought maybe I should take this one off. But in a way, there you get a cross-section of, in a sense an audience response to the website. I've had something like 4 million hits on my website the last few years, so 4 million people have, well that's not true because my family, every day ... I visit my website to keep up the numbers.



- H: Two things I want to come back to. One of them has to do with some of my own interests. I'm thinking of establishing a "digital archive" with this new CFI application, and I'm going to ask you Luciana, from what you've heard now, is it of any practical use to have a digital archive, because I've been thinking initially when I proposed it, I was thinking of a digital archive in terms of the one they have at Nottingham Trent. They have a series of artists whose work is featured. If, for example, I have twenty, thirty people of Stelarc's stature I'll be able to have basically the stuff that he has on his website available on the server, his videos, his pieces, his words. Maybe some documents that he allows when he's finished with them.
- L: So what you are talking about is not a digital archive. You are talking about an archive that is digitally accessible. Because, in fact, nobody has an exclusively digital archive. All archives are hybrid, that is, they are made up of some papers, some films, some microfilms, some postcards, some digital material, etc. But what you are talking about is to make all of the material of each artist accessible through the computer, through the Internet.
- S: That's not to say that with some young artists who really have begun using the Internet itself as a medium of expression, who have always worked in a totally digital fashion, then you might truly be able to have a digital archive, whereas with artists going back further like myself, then it is a hybrid kind of collection of materials.
- L: But even so you know, people who write to you not necessarily write e-mails to you, they might write letters to you. You may have catalogues of your shows; you may have your contracts with the people who exhibit your stuff. That's all part of your archives.
- S: For tax purposes I hide those.
- L: As a matter of fact, what you might not know is that if you donate your archives your taxes are waived. There are tax advantages. The federal government of Canada...
- S: How much?
- L: It depends on how much is the value of your archives. They detract equal to the value of your archives, absolutely. Lots of artists donate their material in order to get the taxes reduced.
- S: But I'm Australian, see...
- L: Most governments have these agreements. Americans have these agreements, too. It's likely that the Australians have the same thing.
- H: This is interesting because, you don't know it but you are going to help me with this, you're going to help me...
- L: I don't know. No, I know.
- S: It's on the record.
- H: I'm actually hoping that your graduate students will be able to furnish the expertise to help me with this digital archive. We've got to talk about this another time.
- L: We will talk about this in another context.
- H: I'm trying to think: how should I format this in a sense that is not only useful to you and your research and to your grad students and their research, but for me and for artists like him, and for the



research community who should be able to access this material? This is the purpose of applying for some of that money, and it's also to tie it in to the work we are doing together for the next few years, to make it practical. This is where I need your input now, and now that you've met at least one artist working in this kind of particular vein, I need some of that advice in being able to structure that archive.

L: Well, we'll see. Its two years away right, the application?

H: Well actually I've just got a WED grant to...

(tape ends)

S: The kind of objects that have been constructed so far that are part of the performances have been my third hand. And that is a hand that resembles a human hand and is controlled by muscle signals. My extended arm, this is a new manipulator connected to the end of my right arm to produce an arm of primate proportions, and this manipulator has wrist rotation, thumb rotation, individual finger movements and each finger opens and closes. So, each finger is a gripper in itself. A motion prosthesis is this sort of upper body exoskeleton that programs the movements of your arms. So three degrees of freedom for each arm that produces sixty-four possible combinations of movements. The six-legged walking robot exoskeleton that is guided by arm gestures, so by making different arm gestures you can select different leg movements of the machine. And the new hexapod, which looks like an insect but will walk like a dog with dynamic locomotion. And in this case, the interface is even more intuitive. In other words, as the body steps up and down on the robot, the raising of each foot alternatively releases three legs to release and sweep forward. So my bipedal locomotion generates the six-legged walking motion. And when I want to change direction the machine is moving, I simply turn my body. The machine walks in the direction I am looking. So, it's really like a sort of normal moving translation of the human bipedal gait into a six-legged machine gait.

H: All these are ...

S: ... are physical objects, yeah.

H: These physical objects, they are yours for you to store, or they belong to the research organizations?

S: No, these are mine.

H: Don't you keep them?

S: Well, for example, the third hand and the stomach sculpture were exhibited here in Vancouver

H: So you give these out to organizations to display.

S: But tomorrow I'm taking it; I'm taking my hand back. The six-legged walking robot, I'm paying for storage in Hamburg. I mean this is a big robot. I'm paying 500 Euros a year to store it.

H: So these could go on exhibit in museums, galleries?

S: Yes, they could, yeah.

H: So these are archived objects.

S: They're objects, yeah.



- H: Now would you, I asked this question earlier, and I come back to it again, maybe because I'm a little obsessed with the idea of someone else using these objects or...
- S: Well, firstly the third hand is designed for the proportions of my real right hand. The acrylic sleeve could only be worn by someone of my approximate size, similar size. The six-legged walking robot, again the upper body exoskeleton would only be able to be worn by someone of my sort of stature, but then they could learn to operate it. But would they want to? The upper body exoskeleton again is made to the proportions of my body, so although in principle someone of a similar size and stature might be able to use the objects, generally they're body specific, to the performance body. The extended arms is a little bit different because it is made in such a way that other people could easily attach it and easily operate it, but that's a little bit different.
- H: But if someone were to go into these wearable objects and perform your piece, let's say...would that be, you wouldn't allow that? Would you allow that? And if they did it would it be like Nijinsky performing or Baryshnikov performing Nijinsky's *Sacre*?
- S: I know what you're getting at. I think it's just that the whole situation is contextually structured in a different way.
- H: I'm looking for connections I guess.
- S: Yeah, I guess you're looking for connections. And I guess it would be possible for someone to get onto the exoskeleton robot and make it walk. And, of course, how the robot performs or how the body on the robot performs is largely determined by the robot's functions. Of course, you may decide to turn left instead of right, to go backwards and forwards instead of sideways walking. But, and also, these machines are not made; they're done on limited budgets. They're not constructed in such durable ways that you could perform with them for long periods of time. Of course, I've used my third hand for a period since 1980, so that's been a performance object that has stayed operational for over a long period of time. But some of these objects aren't necessarily objects that are designed as a sophisticated vehicle that could be used, you know, for long periods of time. Even in a gallery situation. So, for example, my third hand was sitting there inoperative for three months. Although some kinetic artists have designed machines that, in fact, do that. And one of the problems of the museum is to maintain that machine. And if you maintain it, if you replace a malfunctioning part of it, are you in fact retaining the integrity of the machine? Or are you just simply retaining its operations?
- L: But the museum in any way is not retaining the integrity of your work of art because it's not retaining your body that is using the machine. It is just keeping the piece.
- H: Yes, I guess I'm getting to this. What distinguishes that from a piece of sculpture from a piece of visual art?
- L: I think that his performance is actually in the records, and if you don't have the records ... I mean it is in the moment in which it takes place and the only way of perpetuating its existence is having



the record of it. And if you don't have a record in which you have his body together with the machinery that he uses, you really don't have it.

S: But, for example, if the third hand is sold to a museum, one of the things that would make its value greater is if they also buy the rights of the videotape documentation. And so, the third hand might be displayed as an object with a videotape representation of some of the performances that were done. So I think you're right in that respect that in a sense it's the recorded documentation that in a sense gives life to the object.

L: Well, the work of art is not the robot; the robot is a piece of it.

S: Yes. I'm the other piece of it.

L: Nobody ever called you a work of art. My mother always does. It's usually a negative comment. You are a work of art.

H: Do you have any more questions?

L: I don't think we do. I think we have beaten him to death.

S: Gently. You've done it very gently.

L: But I think that questions might come up.

S: What really worries me is if he turns up on my doorstep in Melbourne demanding to see ...

L: ... your sketchbooks. Where are they?

S: I'd have to find them. It would take me a week to find them.

L: I think that what will happen is that once we have transcribed the interview and talked about it, we will come up with additional questions. And in such case we could do one of two things: we could try a phone interview, or try through e-mail asking you to amplify, to elaborate on some of the things that you said. Whatever you prefer.

S: I'd be in two minds. I guess a phone interview would be easier just simply because ...

L: ... because it is less time consuming.

S: Yeah and it's also. I'm a reasonably good typist, I touch type, but it is....

L: The advantage of typing is that you are in control of what you are saying much more than through a phone interview.

S: Well, that's true because you umm and ahh and laugh a lot and things like that.

L: But also you are less distinctive you know. You make up something and you say, "Oh, do I really want to say this".

S: But sometimes there are things that are more easily conveyed by words, or at least.... But I guess if anything was published for any reason in the future, then I would certainly look at it, because then I think that's where the difference is. Because in a verbal interview you umm and ahh, you pause, you blink, you wink. There are certain things you get from the physical presence and physical gestures that the person makes.

L: Even the tone of the voice.

S: Yes, you know, the stress, the pressure, the tension.

L: Ok, so do we say thank you very much? We really appreciate it for giving us all this time? (End of interview).



## **Postscript**

In this thesis, I have taken an approach to research that is consistent with my aims and objectives as an artist/scholar. Coincident with the exploration of technology as a means of articulating my dance practice, I have also linked these explorations to other practices in other disciplinary contexts and to different historical periods. These practices have challenged certain representations of bodies in different social, cultural and political contexts. My aim has been to show that many of the so-called new practices are not as new as we think. Instead, they follow a tradition of redefining as knowledge in one area overlaps and influences that in another.

My arguments have also focused on portraying the computer-human interface as a physical place, as a concept and as a psychological condition, perspectives through which to contest our understanding of intelligence, consciousness and agency. One of my main premises has been that, in an information-oriented age, new forms of knowledge appear at the intersections of disciplines rather than just within them. Hence, transdisciplinarity has been my strategic device for understanding the interests, of widely disparate disciplines and practices, in the body and technology as relationships of performance.

As a choreographer I have approached this thesis as a practice-led assignment, meaning that my practices on and offstage with performers, as well as my contextualization of the practices and methods of others, have led me to formulate a particular perspective on dance and performance. As a scholar, I have used the term choreographing discourse to talk about my work in particular, but I have also used it to identify how dance and performance can contribute to a transdisciplinary perspective on knowledge. Thus, this thesis, as a set of critical and discursive positions on the relationships between contemporary dance, performance studies and new technologies, proposes a different relationship between theory and practice, one that privileges activity over archiving but which allows the human body as archive to function as a dynamic, interactive and experiential entity amongst other bodies. The activity of performance is therefore a means of accessing knowledge that is in the body but which has not been “claimed” by its owner, at the same time cross-referencing this knowledge to that which exists in other bodies. In societies where the written word

holds immense sway in determining how cultural memory is produced, disseminated and maintained, it becomes important to balance the production of such documents with others that are more corporeally grounded.

This thesis has advocated a policy of corporeal re-cognition where bodies are explored as sites of knowledge and contemporary dance practices function as an archaeology and an anthropology of the “lived” body. Since our bodies are living memories of history where complex metanarratives are to be found concerning the nature of our human existence, and our ability to remember is facilitated through performance, the production of the DV “Choreographing Discourse” is a small attempt to address the issue of documenting and/or archiving the practices surrounding my activities. This DVD does not substitute for the live performance, but it tries to capture moments of revisited “lived-ness” with the help of technology. Thus, I hope that my initial claim concerning technology, as a factor that plays a significant role in influencing contemporary dance and new performance practices, at the same time determining how people gather new information and how they synthesize this information into coherent forms of knowledge, has been proven. I also hope that this much-needed research will continue to be explored and developed in the future.



## References

---

### General Introduction, Methodology and Document Structure

<sup>1</sup> This term is examined in the AHRB Review of Research Assessment “Research in the Creative and Performing Arts”, document 4\_92883.pdf 4, September 2003 <[http://www.google.ca/search?q=cache:IJQuCMdcPUEJ:www.ahrb.ac.uk/images/4\\_92883.pdf+AHRB+-+practice+led+research&hl=en&ie=UTF-8](http://www.google.ca/search?q=cache:IJQuCMdcPUEJ:www.ahrb.ac.uk/images/4_92883.pdf+AHRB+-+practice+led+research&hl=en&ie=UTF-8)> [Accessed 12 December 2003]

<sup>2</sup> InterPARES 2 (International Research on Permanent Authentic Records in Electronic Systems) is a project directed by Luciana Duranti, Professor at the University of British Columbia’s School of Library, Archival and Information Studies. This project is designed to address issues of reliability and accuracy of electronic records throughout their life-cycle (from creation to permanent preservation). It also focuses on records produced in experiential, dynamic and interactive environments. InterPARES 2 website can be found at [http://www.interpares.org/ip2/ip2\\_index.cfm](http://www.interpares.org/ip2/ip2_index.cfm) Accessed [12 December 2003]

<sup>3</sup> From a report by Richard Kimbell and David Perry of the Education Research Unit of Goldsmiths University of London entitled “Design and Technology in a Knowledge Economy” <<http://www.engc.org.uk/publications/pdf/D&T.pdf>> Accessed [12 December 2003].

<sup>4</sup> Seattle is home to Bill Gates’ Microsoft Corporation, the Boeing Corporation, and many large commercial and military shipbuilding companies.

<sup>5</sup> <<http://www.cityofseattle.net/tech/indicators/report.htm>> Seattle Community Technology Program, “2000-2001 Information Technology Indicators for a Healthy Community” report. [Accessed 12 December 2003]

<sup>6</sup> A Public Broadcasting Service (PBS) documentary aired on March 27, 2002, which looks at the learning difficulties of five children and their relationship with some of the new technologies like online interactive video games. It was produced and directed by Michael Kirk as a co-production for the Kirk Documentary Group, Ltd. and WGBH Boston. Executive directors were Michele Korf and Brigid Sullivan. The Misunderstood Minds Project consists of this documentary, an online website at <[www.pbs.org/misunderstoodminds](http://www.pbs.org/misunderstoodminds)>, and the Developing Minds Multimedia Library. [Accessed Dec. 19 2003]

### Chapter I

<sup>1</sup> The notion of psyche is defined here as a complex where physical, mental and emotional experiences are stored, sometimes synthesized, and mostly forgotten in memory, but which continues to influence our actions in an unconscious manner.

<sup>2</sup> The logic used in these paragraphs is influenced by Douglas Walton’s *Argument Structure: A Pragmatic Theory* (Toronto, Buffalo, London: University of Toronto Press, 1996)

<sup>3</sup> DV8 Website, “For Students and Researchers”, <<http://www.dv8.co.uk/studentinfo/stud.folder.html>> [Accessed 19 February 2003]



- 
- <sup>4</sup> DV8 Website, "Frequently Asked Questions",  
<<http://www.dv8.co.uk/faqs/faqs.folder.html>> [Accessed 19 February 2003]
- <sup>5</sup> Keith Watson, *The Observer* online at <<http://www.dv8.co.uk/faqs/faqs.folder.html>>  
10 September 1995 (Accessed 19 February 2003)
- <sup>6</sup> Judith Mackrell, *The Independent*, online at  
<<http://www.dv8.co.uk/faqs/faqs.folder.html>> 1 August 1992 [Accessed 19 February  
2003]
- <sup>7</sup> Dramatization of Brian Masters' *Killing for Company: The Case of Dennis Nilsen*  
(London: Cape, 1985) Based on British serial killer Dennis Nilsen
- <sup>8</sup> Clement Crisp, *Financial Times* 4 November 1988 online at  
<<http://www.dv8.co.uk/faqs/faqs.folder.html>> [Accessed 4 February 2003]
- <sup>9</sup> Judith Mackrell *The Guardian*, online at  
<<http://www.dv8.co.uk/faqs/faqs.folder.html>> 22 September 1995 [Accessed 19  
February 2003]
- <sup>10</sup> DV8 website <<http://www.dv8.co.uk/>> [Accessed 19 February 2003]
- <sup>11</sup> The full title of this work is "*Auf dem Gebirge hat man ein Geschrei gehört*" (trans.  
"On the Mountain a Cry Was Heard")
- <sup>12</sup> See video of *NU* in Appendix II
- <sup>13</sup> A trademark brand name for an ultrasonic device marketed by Elektrodome of  
Bristol that senses movement in space and reacts to it by triggering sound impulses  
via the MIDI protocol (Musical Instrument Digital Interface)
- <sup>14</sup> The Cunningham Dance Company's website <<http://www.merce.org/>> [Accessed  
19 February 2003]
- <sup>15</sup> The notion of "post-modern" here refers to its position coming after the early  
Modern Dance. See Banes (1987, 1994)
- <sup>16</sup> Life Forms was the first major development in new technology that allowed  
choreographers to create works on virtual bodies using the computing platform.  
Conceived as an MA thesis by Kinesiology graduate Zella Wolofsky at Simon Fraser  
University in Vancouver, Canada <<http://www.sfu.ca/vpresearch/rm/lifeforms.html>>,  
it was subsequently developed by a team of researchers headed by Tom Calvert  
<<http://www.cs.sfu.ca/people/Faculty/tom/research.html>>. Life Forms became a  
milestone in dance technology. The product is now commercially marketed by  
CREDO INTERACTIVE in Vancouver <<http://www.credo-interactive.com/>>  
[Accessed 19 February 2003]
- <sup>17</sup> Geocities Website  
<<http://www.geocities.com/Athens/Parthenon/5862/pan3egypt.html>> [Accessed 19  
February 2003]
- <sup>18</sup> It is sometimes the case working with these expensive technologies that performers  
do not have access to them for any length of time. There are a number of solutions to  
this dilemma, all of which involve a degree of structured improvisations in which the  
performers interact for a limited time with the equipment, usually in a performance  
environment. In *NU*, these improvisations took place without the technology so that  
the performance took on more of a structured approach.
- <sup>19</sup> <<http://www.kheper.net/kheper/kheper.htm>> [Accessed 19 February 2003]
- <sup>20</sup> Peter Badejo is one of the more important Nigerian choreographers working out of  
the UK. <<http://www.badejo.demon.co.uk/>> [Accessed 16 March 2003]
- <sup>21</sup> (Musical Instrument Digital Interface). MIDI essentially sends information, which  
is used to trigger other events: it allows electronic devices (synthesizers, light show  
controllers, VCR's, multi-track recorders, and generally speaking all computer



---

controlled devices) to interact and work in synchronization with other MIDI compatible devices. Through a single master controller, a variety of instructions can be implemented locally and remotely.

<sup>22</sup> *Shango* and *Ogun* are “gods” or archetypical figures from the West African Yoruba tradition. See this work on the accompanying DVD “Choreographing Discourse”.

<sup>23</sup> See accompanying DVD “Choreographing Discourse”.

<sup>24</sup> See accompanying DVD “Choreographing Discourse”.

## Chapter II

<sup>1</sup> All references to Maurice Merleau-Ponty in this section come from the general introduction to his *Phenomenology of Perception* (1962).

<sup>2</sup> Schechner uses this term in a number of his writings on performance studies.

<sup>3</sup> “Metakinesis” and “kinetic transfer” have numerous references throughout John Martin’s writings on dance.

<sup>4</sup> The context here is Stanislavsky’s theory of acting, one that stressed truth and realism in the training of the actor.

<sup>5</sup> Daniel, H. *The Force of Experience: A Key Parameter for Dance*. Unpublished MA Dissertation (City University London, The Laban Centre for Movement and Dance, 1995). Music for *Walk-About-Timeless* was composed by Gareth Giles. This production premiered at the Riverside Studios, Hammersmith, London, 13 July 1995 and was choreographed and designed by myself. The dancers were Mia Atsugi, Louise Chalwell, Sue Harvey, Holly Rook, Amy Whitworth, Chizuko Yoshifuku, Yemi Adenle, Jason Barden, Marco Brénugat, Henry Daniel and Ben Love. Michael Mannion designed the lighting and Sarah Morris the costumes.

<sup>6</sup> Taken from Olivier Messiaen’s *The Technique of My Musical Language* trans. by John Satterfield. (Paris: A. Leduc, 1956)

<sup>7</sup> “An examination of the life and musical style of Olivier Messiaen, 1908-1992” p. 4 (2001) <<http://www.musicteachers.co.uk/resources/>> [Accessed 22 June 2003]

<sup>8</sup> “An examination of the life and musical style of Olivier Messiaen, 1908-1992” p. 5 (2001) <<http://www.musicteachers.co.uk/resources/>> [Accessed 22 June 2003]

<sup>9</sup> “An examination of the life and musical style of Olivier Messiaen, 1908-1992” p. 5 (2001) <<http://www.musicteachers.co.uk/resources/>> [Accessed 22 June 2003]

<sup>10</sup> Henry Daniel, unpublished MA Thesis (London: The Laban Centre, 1995)

<sup>11</sup> “An examination of the life and musical style of Olivier Messiaen, 1908-1992” p. 2 (2001) <<http://www.musicteachers.co.uk/resources/>> [Accessed 22 June 2003]

<sup>12</sup> “An examination of the life and musical style of Olivier Messiaen, 1908-1992” p. 2 (2001) <<http://www.musicteachers.co.uk/resources/>> [Accessed 22 June 2003]

## Chapter III

<sup>1</sup> From a report by Richard Kimbell and David Perry of the Education Research Unit of Goldsmiths University of London entitled “Design and Technology in a Knowledge Economy” <<http://www.engc.org.uk/publications/pdf/D&T.pdf>> Accessed [12 December 2003].

<sup>2</sup> From the Charles Simonyi Lecture at Oxford University, Feb 17, 1999 [http://www.edge.org/3rd\\_culture/dennett/dennett\\_p1.html](http://www.edge.org/3rd_culture/dennett/dennett_p1.html) Accessed [12 December 2003]



---

<sup>3</sup> Turing was one of the team that broke the secret Enigma code that German submarines used to destroy Allied shipping during the Second World War.

<sup>4</sup> The so-called Moore's Law. Gordon E. Moore (1929- ) is the co-founder of Intel Corporation and the author of Moore's Law.

<[http://www.campusprogram.com/reference/en/wikipedia/m/mo/moore\\_s\\_law.html](http://www.campusprogram.com/reference/en/wikipedia/m/mo/moore_s_law.html)> [Accessed 22 June 2003].

<sup>5</sup> BBC 1 TV re-broadcast of a taped interview with choreographer William Forsythe, 27 December 1996.

<sup>6</sup> The Middle Passage was the journey of slave trading ships from the coast of West Africa across the Atlantic to the Caribbean, North, Central and South America.

<sup>7</sup> Performance venues for *Shango Meets Ogun* included the John Stripe Theatre, King Alfred's College Winchester [December 3 1998], a live Internet broadcast at The Global Café [Tuesday 3rd August 1999], <[http://www.globalcafe.biz/global\\_past/](http://www.globalcafe.biz/global_past/)> [Accessed 19 February 2003], 5th Performance Studies Conference Aberystwyth, Wales [11 April, 1991], Manchester Metropolitan University "Momentum" Dance Theatre Conference [11 September, 1999] and the Purcell Room, Queen Elizabeth Theatre on London's South Bank [11-13 February 2000]

<sup>8</sup> Orishas are emissaries of Olodumare or God Almighty, who rule over the forces of nature and the endeavours of humanity

<<http://www.seanet.com/~efunmoyiwa/ocha.html>> [Accesses 22 June 2003]

<sup>9</sup> Program notes from the single performance of this work.

## Chapter IV

<sup>1</sup> In a television interview broadcast by ABC where Jones spoke at length about his experience working with Paul Kaiser and Shelley Eshkar, the same team that collaborated with Merce Cunningham on *BIPED*. Jones claimed that the images captured reflected him more accurately than any video images he had ever seen. He also claimed that the figures had an identity and seemed to "want something".

<sup>2</sup> Ogun was the first deity to bridge the gap between humans and gods. As a reward, both parties jointly offered him a crown. He at first declined but later accepted. In his first battle on earth, he could recognize neither friend nor foe and in his blindness slaughtered the people he was meant to serve.

<<http://www.angelfire.com/fl3/OGUN/>> [Accessed 2 July 2003]

<sup>3</sup> < <http://www.umfa.utah.edu/index.php?id=NDE5>> [Accessed 2 July 2003]

<sup>4</sup> < <http://www.ecsel.psu.edu/~jss264/medieval.htm>> [Accessed 2 July 2003]

<sup>5</sup> < <http://www.angelfire.com/fl3/OGUN/>> Accessed 2 July 2003]

<sup>6</sup> <<http://www.d.umn.edu/cla/faculty/troufs/anth1602/pctimes.html>> [Accessed 2 July 2003]

<sup>7</sup> The sage Kapila is reported to have written down his teachings in the Samkhya Pravachana Sutra, which was subsequently lost. Patanjali is reported to have written down the Yoga Sutras at a time that is also unknown but estimated to be between c. 300 BC to AD 300.

<<http://www.uga.edu/religion/rk/basehtml/guides/YOGA.html>> [Accessed 2 July 2003]

<sup>8</sup> Filippo Taglioni (choreographer), Adolphe Nourrit (libretto/scenario), Jean Schneitzhoeffter (music). Premiere was March 12, 1832 at the Paris Opera. Danced by Marie Taglioni and Joseph Mazilier based on the story by Charles Nodier



---

<[http://androsdance.tripod.com/biographies/taglioni\\_family.htm](http://androsdance.tripod.com/biographies/taglioni_family.htm)> [Accessed 2 July 2003]

<sup>9</sup> Visual perception depends on our ability to receive impressions at a very fast rate. Our quickest visual perception is 1/10,000 second, compared to the existence of an electron, which is equal to 1/30,000 of 1/10,000 of a second. This latter is one-three hundred-millionth part of a second, the time it takes an electron to make seven million revolutions round the proton (Ouspensky, 1983: 336).

<sup>10</sup> Reiter, Nicholas A. & Schillig, Lori L. "Photograph M1 and Its Implications: Toward an Understanding of the Invisible". [Accessed 9 August 1997].

<<http://www.theavalonfoundation.org/m1photo.htm>> [Accessed 2 July 2003]

<sup>11</sup> See works on the DVD "Choreographing Discourse".

<sup>12</sup> The inverse of every harmonic progression is an arithmetic progression. The insertion of the harmonic and arithmetic means between the two extremes in double ratios, representing the octave double, which gives us the progression known as the "musical" proportion, that is 1, 4/3, 3/2, 2. These ratios correspond to the fundamental, fourth, fifth and octave. In music, the ascending fifth from the fundamental is the same note as the descending fourth from the octave note. The same is true vice versa. An ascending fourth is the same as a descending fifth. These two steps stabilize the octave from within forming a type of gateway that determines the way that sounds, or experiences as events, go through transformations in their further ascent or descent. If the fifth note is attained in relation to the tonic in the harmonic scale, all other fifths can be reached in a circle of twelve keys. The harmonic series is a universal musical fact and can be mathematically calculated and scientifically measured (Lawlor, pp. 80-89, 1982).

## Chapter V

<sup>1</sup> Saint Point was the great-granddaughter of Lamartine (1790–1869), French poet and statesman.

<sup>2</sup> Loy showed her paintings in the First International Futurist Art Exhibition in 1914.

<sup>3</sup> This talent can be seen in *Unique Form of Continuity in Space* (1913), *States of Mind* series (1911), *The City Rises* (1910), *Dynamism of a Cyclist* (1913), *Dynamism of a Man's Head* and *Dynamism of a Woman's Head* (1914).

<sup>4</sup> See <[http://www.moma.org/collection/conservation/demoiselles/analysis\\_1.html](http://www.moma.org/collection/conservation/demoiselles/analysis_1.html)> [Accessed 15 March 2004]

<sup>5</sup> Aleksei Gastev was an *avant-garde* "production poet" who combined futurist poetics with proletarian politics in his work. See essay by Karen McCauley (1995) <<http://www.humnet.ucla.edu/humnet/slavic/diss/McCauley.html>>. Accessed 19 February 2003]

<sup>6</sup> <<http://guardian.curtin.edu:16080/cga/teach-in/psych/>> [Accessed 19 February 2003]

<sup>7</sup> <<http://members.tripod.com/~FroebelWeb/web2018.html>> [Accessed 19 February 2003]

<sup>8</sup> Illustrations (Figs 2–12) © Emory University,

<<http://www.emory.edu/ENGLISH/DRAMA/HistDrama2/ExpressionImage.html>>

[Accessed 1

9 February 2003]



---

## Chapter VI

<sup>1</sup> Stelarc <<http://www.stelarc.va.com.au/obsolete/obsolete.html>> [Accessed 19 February 2003]

<sup>2</sup> Norbert Wiener, "Cybernetics", *Scientific American*, (1948) 179: 14–19.

<sup>3</sup> "Conceptualising Cyberspace", <<http://www.cc.jyu.fi/~jarpelt/cyberw.htm>> [Accessed 19 February 2003]

<sup>4</sup> This principle states that each way of describing existence, as a wave or as a particle, complements the other, and that a whole picture emerges only from both taken together (Zohar, 1990, 1991 & Hawking, 1988, 1995).

<sup>5</sup> This principle states that while both the wave and the particle description of existence are necessary for complete understanding, only one is available at any given time (Zohar, 1990, 1991 & Hawking, 1988, 1995).

<sup>6</sup> "Virtual Dance", online at

<http://www.culturekiosque.com/dance/reviews/rhecun.html>> [Accessed 19 February 2003.] Patricia Boccadoro writes on dance from Paris and contributes to the *Guardian*, the *Observer* and *Dancing Times*. She was dance consultant to the BBC Omnibus documentary on Rudolf Noreen and is Dance editor of <<http://Culturekiosque.com/>>.

<sup>7</sup> William Forsythe's "Improvisation Technologies", a detailed inscribing of his choreographic method in CD-ROM format, is one such case in point.

<sup>8</sup> "Hand drawn Spaces",

<<http://www.riverbed.com/artworks/handdrawn/handmain.htm>> [Accessed 15 March 2000]

<sup>9</sup> Roy, S "Where Flesh Meets Form",

<<http://www.danceservice.co.uk/articles/biped.html>> [Accessed 15 March 2000.]

<sup>10</sup> Ballet Frankfurt, <<http://www.frankfurt-ballett.de/frame.html>> [Accessed 15 March 2000]

<sup>11</sup> All text taken from The Frankfurt Ballet's Web site at <<http://www.frankfurt-ballett.de/frame.html>> [Accessed 15 March 2000]

<sup>12</sup> See artist's website at <http://www.stelarc.va.com.au/obsolete/obsolete.html> [Accessed 10 March 2004] Most of the references in this chapter are taken from my interview with the artist reproduced in Chapter VII, and from writings archived on his personal website.

<sup>13</sup> Some of these events are *Event for Penetrations/Extrapolation* (1976), *Event for Lateral Suspension* (1978), *Event for Propped Body* (1978), *Sitting/Swaying: Event for Rock Suspension* (1980), *Seaside Suspensions: Event for Wind and Waves* (1981).

<sup>14</sup> <<http://www.msstate.edu/Fineart/Online/Gallery/Stelarc/stelarc.html>> [Accessed 19 February 2003] Stelarc interviewed in *Obsolete Body/Suspensions/Stelarc*.

<sup>15</sup> Stelarc's performances took place at the Western Front and at Simon Fraser's Harbour Centre Campus in Vancouver as part of the VAG's lecture, exhibition and performance series "The Uncanny: Experiments in Cyborg Culture", from February to May 2002. Project Leader Luciana Duranti and I conducted the interview with the artist for InterPARES 2 (International Research on Permanent Authentic Records in Electronic Systems) on 2 June 2002. Details of this interview form the bulk of Chapter VII of this thesis.

<sup>16</sup> Mary Shelley's *Frankenstein* is an example of the machine as humanity's ultimate other. *Frankenstein* is the story of a modern Prometheus as a scientist and creator



---

rather than a thief of fire. Man abandons his creation and suffers a moral dilemma in the aftermath of the destruction wreaked by the monster. The creature is assembled from stolen body parts and brought into a world for which he/it is unprepared. Shunned by humanity, it nevertheless develops human qualities. Important moral and ethical questions are posed here, not the least of which is whether one can in fact bestow life in lifeless matter and not take responsibility for the consequences of one's actions.

## **Chapter VII**

<sup>1</sup> Conducted June 2 2002 at the Crowne Plaza Hotel, 801 West Georgia Street, Vancouver, BC, Canada. The completed case study report for InterPARES 2 is available on the InterPARES's website at [http://www.interpares.org/rws/ip2\\_cs\\_document.cfm?cs=CS02](http://www.interpares.org/rws/ip2_cs_document.cfm?cs=CS02) [Accessed 15 June 2004].

---

## Composite Bibliography

- Adshead-Lansdale, Janet. Border Tensions: Dance and Discourse: Proceedings of the Fifth Study of Dance Conference, University of Surrey, April 20-23, 1995. Guildford, England: National Resource Centre for Dance University of Surrey, 1995.
- Allen, Graham. Intertextuality. New York: Routledge, 2000.
- Andersen, Birgitte. Knowledge and Innovation in the New Service Economy. Cheltenham, UK; Northampton, MA, USA: Edward Elgar, 2000.
- Anderson, Jack. Ballet & Modern Dance: A Concise History. Princeton, N.J.: Princeton Book Co., 1986.
- Angelou, Maya. Even the Stars Look Lonesome. New York: Random House, 1997.
- Apollonio, Umbro. Futurist Manifestos. London Thames and Hudson, 1973.
- Arnheim, Rudolf. Art and Visual Perception: A Psychology of the Creative Eye. New ed. Berkeley: University of California Press, 1974.
- Asch, Ronald. The Thirty Years War: The Holy Roman Empire and Europe, 1618-1648. Basingstoke, Hampshire: Macmillan; New York: St. Martin's Press, 1997.
- Au, Susan. Ballet and Modern Dance. 2nd ed. New York: Thames & Hudson, 2002.
- Badmington, Neil. Posthumanism. Readers in Cultural Criticism. Houndmills, Basingstoke, Hampshire; New York: Palgrave, 2000.
- Banes, Sally. Democracy's Body: Judson Dance Theater, 1962-1964. Ann Arbor, Mich.: UMI Research Press, 1983.
- . Terpsichore in Sneakers: Post-Modern Dance. Middletown, Conn. Scranton, Pa.: Wesleyan University Press; Distributed by Harper and Row, 1987.
- . Greenwich Village 1963: Avant-Garde Performance and the Effervescent Body. Durham: Duke University Press, 1993.
- . Writing Dancing in the Age of Postmodernism. Hanover, N.H.: University Press of New England, 1994.
- . Subversive Expectations: Performance Art and Paratheater in New York, 1976-85. Ann Arbor, MI: University of Michigan Press, 1998.
- Barba, Eugenio, and Nicola Savarese. A Dictionary of Theatre Anthropology: The Secret Art of the Performer. London; New York: Routledge: In association with the Centre for Performance Research, 1991.
- Barba, Eugenio. The Paper Canoe: A Guide to Theatre Anthropology. London; New York: Routledge, 1995.
- Barthes, Roland. Elements of Semiology. London: J. Cape, 1967.
- . Mythologies. London: J. Cape, 1972.
- . Empire of Signs. London: J. Cape, 1982.
- Baudelaire, Charles. Baudelaire as a Literary Critic: Selected Essays. University Park: Pennsylvania State University Press, 1964.
- . Salon de 1846/ texte établi et présenté par David Kelley. Oxford: Clarendon Press, 1975.
- Baudrillard, Jean, and Mark Poster. Selected Writings. Stanford, Calif.: Stanford University Press, 1988.
- Baudrillard, Jean, et al. Fatal Strategies. London: Semiotexte/Pluto, 1990.
- Baudrillard, Jean. Simulacra and Simulation. Ann Arbor: University of Michigan



- 
- Press, 1994.
- Bauman, Zygmunt. Modernity and Ambivalence. Cambridge, Eng.: Polity Press, 1991.
- Bell, David. An Introduction to Cybercultures. New York, N.Y.: Routledge, 2001.
- Bender, Gretchen, Timothy Druckrey, and Dia Center for the Arts (New York, N.Y.). Culture on the Brink: Ideologies of Technology. Seattle: Bay Press, 1994.
- Benjamin, Walter, Hannah Arendt, and Harry Zohn. Illuminations. New York: Schocken Books, 1988.
- Berghaus, Günter. Italian Futurist Theatre, 1909-1944. Oxford; New York: Clarendon Press, 1998.
- . International Futurism in Arts and Literature. European Cultures; V. 13. Berlin; New York: Walter de Gruyter, 2000.
- Bergson, Henri, Herbert Dingle, and Leon Jacobson. Duration and Simultaneity, with Reference to Einstein's Theory. Indianapolis: Bobbs-Merrill, 1965.
- Bergson, Henri. The Creative Mind. New York: Greenwood Press, 1968.
- . Matter and Memory. New York: Zone Books, 1988.
- . Creative Evolution. Mineola, N.Y.: Dover, 1998.
- Bergson, Henri, Keith Ansell-Pearson, and John Mullarkey. Key Writings. New York: Continuum, 2002.
- Bial, Henry. The Performance Studies Reader. London: Routledge, 2003.
- Birringer, Johannes H. Theatre, Theory, Postmodernism. Drama and Performance Studies. Bloomington: Indiana University Press, 1991.
- . Media & Performance: Along the Border. Paj Books. Baltimore, Md.; London: Johns Hopkins University Press, 1998.
- . Performance on the Edge: Transformations of Culture. London New Brunswick, NJ: Athlone Press, 2000.
- Blakemore, Colin, and Susan Greenfield. Mindwaves: Thoughts on Intelligence, Identity, and Consciousness. Oxford, UK; New York, NY: B. Blackwell, 1987.
- Blom, Lynne Anne, and L. Tarin Chaplin. The Intimate Act of Choreography. Pittsburgh, Pa.: University of Pittsburgh Press, 1982.
- Bohm, David, and F. David Peat. Science, Order, and Creativity. 2nd ed. London: Routledge, 2000.
- Bourdieu, Pierre, and Randal Johnson. The Field of Cultural Production: Essays on Art and Literature. Cambridge England: Polity Press, 1993.
- Brand, Stewart. The Media Lab: Inventing the Future at MIT. New York, NY: Viking, 1987.
- Brand, Dionne. A Map to the Door of No Return. Toronto: Doubleday Canada, 2001.
- Braun, Edward. Meyerhold: A Revolution in Theatre. 2nd ed. London: Methuen, 1995.
- Bremser, Martha. Fifty Contemporary Choreographers. London: Routledge, 1999.
- Brook, James, and Iain A. Boal. Resisting the Virtual Life: The Culture and Politics of Information. San Francisco, Monroe, OR: City Lights; Subterranean Co. distributor, 1995.
- Brooker, Peter. Modernism/Postmodernism. London; New York: Longman, 1992.
- Bruno, Giordano. Cause, Principle, and Unity: Five Dialogues. [Castle Hedingham, Essex: Daimon Press, 1962.
- Bruno, Giordano, Robert de Lucca, and Richard J. Blackwell. Cause, Principle and Unity. Cambridge, UK; New York: Cambridge University Press, 1998.



- 
- Budge, E. A. Wallis. Egyptian Religion: Egyptian Ideas of the Future Life. Seacaucus, N.J.: University Books, 1959.
- Burke, Carolyn. Becoming Modern: The Life of Mina Loy. 1st ed. New York: Farrar Straus and Giroux, 1996.
- Burt, Ramsay. Alien Bodies: Representations of Modernity, "Race," and Nation in Early Modern Dance. London; New York: Routledge, 1998.
- Bynum, Edward Bruce, and NetLibrary Inc. The African Unconscious: Roots of Ancient Mysticism and Modern Psychology. New York, N.Y.: Teachers College Press, 1999.
- Campbell, Patrick. Analysing Performance: A Critical Reader. Manchester; New York New York: Manchester University Press; Distributed exclusively in the USA and Canada by St. Martin's Press, 1996.
- Cangelosi, Angelo, and Domenico Parisi. Simulating the Evolution of Language. London; New York: Springer, 2002.
- Capra, Fritjof. The Tao of Physics: An Exploration of the Parallels between Modern Physics and Eastern Mysticism. Flamingo. London: Fontana Paperbacks, 1983.
- Carter, Alexandra. The Routledge Dance Studies Reader. London; New York: Routledge, 1998.
- Caruana, Wally. Aboriginal Art. New ed. New York: Thames & Hudson, 2003.
- Chatwin, Bruce. The Songlines. New York, N.Y., U.S.A.: Penguin Books, 1988.
- Ciane, Fernando. Pina Bausch and the Wuppertal Dance Theater: The Aesthetics of Repetition and Transformation. Foreword by RoseLee Goldberg and a preface by Susanne Schlichler. New York: P. Lang, 2001
- Cixous, Hélène. Angst. London New York: J. Calder; Riverrun Press, 1985.
- Cohen, Marshall, and Roger Copeland. What Is Dance?: Readings in Theory and Criticism. Oxford Oxfordshire; New York: Oxford University Press, 1983.
- Cole, David. The Theatrical Event: A Mythos, a Vocabulary, a Perspective. Middletown, Conn.: Wesleyan University Press, 1975.
- Colston Research Society. Symposium. (1997: University of Bristol), and Günter Berghaus. New Approaches to Theatre Studies and Performance Analysis: Papers Presented at the Colston Symposium, Bristol, 21-23 March 1997. Tübingen: Niemeyer, 2001.
- Condé, Maryse. I, Tituba, Black Witch of Salem. Charlottesville: University Press of Virginia, 1992.
- Copeland, Roger. Merce Cunningham: The Modernizing of Modern Dance New York: Routledge, 2004
- Corbally Stourton, Patrick. Songlines and Dreamings: Contemporary Australian Aboriginal Painting: The First Quarter Century of Papunya Tula. London: Lund Humphries, 1996.
- Crick, Francis. Life Itself: Its Origin and Nature. New York: Simon and Schuster, 1981.
- . The Astonishing Hypothesis: The Scientific Search for the Soul. New York: Scribner; London: Maxwell Macmillan International, 1994.
- Cumming, Robert Denoon. Phenomenology and Deconstruction. Chicago: University of Chicago Press, 1991.
- Cunningham, Merce, and Frances Starr. Changes: Notes on Choreography. New York: Something Else Press, 1969.
- Cunningham, Merce, et al. Art Performs Life: Merce Cunningham, Mercedith Monk,



- 
- Bill T. Jones. Minneapolis, New York, N.Y.: Walker Art Center; Available through Distributed Art Publishers, 1998.
- Daly, Ann. Critical Gestures: Writings on Dance and Culture. Middletown, Conn.: Wesleyan University Press, 2002.
- Darwin, Charles. The Origin of Species by Means of Natural Selection, or, the Preservation of Favored Races in the Struggle for Life. Authorized ed. 2 vols. New York: D. Appleton, 1898.
- . The Descent of Man, and Selection in Relation to Sex. Rev. ed. Detroit: Gale Research, 1974.
- da Vinci, L & Edward MacCurdy. The Notebooks of Leonardo Da Vinci. London: J. Cape, 1977.
- Dawkins, Richard. The Selfish Gene. Oxford: Oxford University Press, 1976.
- . The Blind Watchmaker. Harlow: Longman Scientific & Technical, 1986.
- . Climbing Mount Improbable. London: Viking, 1996.
- De Nooy, Julia. Derrida, Kristeva, and the Dividing Line: An Articulation of Two Theories of Difference. Garland Reference Library of the Humanities; V. 2078, Comparative Literature and Cultural Studies; V. 5. New York; London: Garland Publishing, 1998.
- DeFrantz, Thomas. Dancing Many Drums: Excavations in African American Dance. Madison, Wis.: University of Wisconsin Press, 2002.
- DeLancey, Craig. Passionate Engines: What Emotions Reveal About Mind and Artificial Intelligence. New York: Oxford University Press, 2002.
- Deleuze, Gilles, and Félix Guattari. Anti-Oedipus: Capitalism and Schizophrenia. Minneapolis: University of Minnesota Press, 1983.
- . What Is Philosophy? New York: Columbia University Press, 1994.
- Deleuze, Gilles, and Claire Parnet. Dialogues II. 2nd ed. New York, NY: Columbia University Press, 2002.
- Denby, Edwin, Robert Cornfield, and William MacKay. Dance Writings. New York: Knopf, 1986.
- Dennett, Daniel Clement. Consciousness Explained. Boston: Little Brown and Co., 1991.
- . Kinds of Minds: Toward an Understanding of Consciousness. New York: Basic Books, 1996a.
- . Darwin's Dangerous Idea: Evolution and the Meanings of Life. 1st Touchstone ed. New York: Simon & Schuster, 1996b.
- . Freedom Evolves. New York: Viking, 2003.
- Depraz, Natalie, Francisco J. Varela, and Pierre Vermersch. On Becoming Aware: A Pragmatics of Experiencing. Amsterdam; Philadelphia: J. Benjamins, 2003.
- Deren, Maya. Divine Horsemen: Voodoo, Gods of Haiti. New York: Chelsea House, 1970.
- Derrida, Jacques. Speech and Phenomena, and Other Essays on Husserl's Theory of Signs. Evanston: Northwestern University Press, 1973.
- . Writing and Difference. Chicago: University of Chicago Press, 1978.
- . Of Grammatology. Corrected ed. Baltimore: Johns Hopkins University Press, 1998a.
- Derrida, Jacques, and Derek Attridge. Acts of Literature. New York: Routledge, 1992.
- Derrida, Jacques, and John D. Caputo. Deconstruction in a Nutshell: A Conversation with Jacques Derrida. New York: Fordham University Press, 1997.
- Derrida, Jacques, and Julian Wolfreys. The Derrida Reader: Writing Performances.



- 
- Lincoln: University of Nebraska Press, 1998b.
- Dery, Mark. Escape Velocity: Cyberculture at the End of the Century. New York: Grove Press, 1996.
- Descartes, Renée, John Cottingham, and Bernard Arthur Owen Williams. Meditations on First Philosophy: With Selections from the Objections and Replies. Rev. ed. New York: Cambridge University Press, 1996a.
- Descartes, Renée, David Weissman, and William Theodore Bluhm. Discourse on the Method; and, Meditations on First Philosophy. New Haven, Conn.: Yale University Press, 1996b.
- Desmond, Jane. Meaning in Motion: New Cultural Studies of Dance. Durham, N.C.; London: Duke University Press, 1997.
- . Dancing Desires: Choreographing Sexualities on and off the Stage. Madison: University of Wisconsin Press, 2001.
- Deutsch, David. The Fabric of Reality: The Science of Parallel Universes-- and Its Implications. New York: Allen Lane, 1997.
- Dewey, John. Art as Experience. New York: Capricorn Books, 1958.
- Dilman, Ilham, B. F. Skinner, and John R. Searle. Mind, Brain and Behaviour: Discussions of B.F. Skinner and J.R. Searle. London: Routledge, 1988.
- Dils, Ann, and Ann Cooper Albright. Moving History, Dancing Cultures: A Dance History Reader. Middletown, CT: Wesleyan University Press, 2001.
- Dinerstein, Joel. Swinging the Machine: Modernity, Technology, and African American Culture between the World Wars. Amherst: University of Massachusetts Press, 2003.
- Dinkla, Söke, and Martina Leeker. Tanz Und Technologie: Auf Dem Weg Zu Medialen Inszenierungen = Dance and Technology: Moving Towards Media Productions. Berlin: Alexander, 2002.
- Drewal, Margaret Thompson. Yoruba Ritual: Performers, Play, Agency. Bloomington: Indiana University Press, 1992.
- Dreyfus, Hubert L. What Computers Still Can't Do: A Critique of Artificial Reason. Cambridge, Mass.: MIT Press, 1992.
- Du Bois, W. E. B. The Souls of Black Folk. New York: Bantam Books, 1989.
- Durkheim, Emile. The Division of Labour in Society. 2d ed. London: Macmillan, 1984.
- Dyens, Ollivier. Metal and Flesh: The Evolution of Man: Technology Takes Over. Cambridge, Mass.: MIT Press, 2001.
- Dyson, George. Darwin among the Machines: The Evolution of Global Intelligence. Reading, Mass.: Addison-Wesley Pub. Co., 1997.
- Edinger, Edward F., and Deborah A. Wesley. The Aion Lectures: Exploring the Self in C.G. Jung's Aion. Toronto, Canada: Inner City Books, 1996.
- Eliade, Mircea. Yoga: Immortality and Freedom. 2d. ed. Princeton N.J.: Princeton University Press, 1970.
- Elveton, R. O. The Phenomenology of Husserl: Selected Critical Readings. Chicago: Quadrangle Books, 1970.
- Eze, Emmanuel Chukwudi. African Philosophy: An Anthology. Malden, Mass.: Blackwell Publishers, 1998.
- Fawcett, Brian. Cambodia: A Book for People Who Find Television Too Slow. Vancouver, B.C.: Talonbooks, 1986.
- Featherstone, Mike, and Roger Burrows. Cyberspace/Cyberbodies/Cyberpunk: Cultures of Technological Embodiment. London: Sage, 1995.



- 
- Fer, Briony, David Batchelor, and Paul Wood. Realism, Rationalism, Surrealism: Art between the Wars. New Haven: Yale University Press in association with the Open University, 1993.
- Ferguson, Harvie. Modernity and Subjectivity: Body, Soul, Spirit. Charlottesville: University Press of Virginia, 2000.
- Feuerstein, Georg A. The Philosophy of Classical Yoga. Manchester: Manchester University Press, 1980.
- Fischer-Hornung, Dorothea, and Alison D. Goeller. Embodying Liberation: The Black Body in American Dance. Forecaast; 4. Munster: Lit Verlag, 2001.
- Fodor, Jerry A., and Jerrold J. Katz. The Structure of Language: Readings in the Philosophy of Language. Englewood Cliffs, N.J.: Prentice-Hall, 1964.
- Foster, John. The Influences of Rudolph [I.E. Rudolf] Laban. London: Lepus Books, 1977.
- Foster, Susan Leigh. Reading Dancing: Bodies and Subjects in Contemporary American Dance. Berkeley: University of California Press, 1986.
- . Choreographing History. Unnatural Acts. Bloomington: University of Indiana Press, 1995a.
- . Corporealities: Body, Knowledge, Culture, Power. London; New York: Routledge, 1995b.
- Foucault, Michel. Discipline and Punish: The Birth of the Prison. 2nd Vintage Books ed. New York: Vintage Books, 1995.
- Fraleigh, Sondra Horton. Dance and the Lived Body: A Descriptive Aesthetics. Pittsburgh, Pa.: University of Pittsburgh Press, 1987.
- Franko, Mark. Dancing Modernism/Performing Politics. Bloomington: Indiana University Press, 1995.
- Freud, Sigmund, and A. A. Brill. The Basic Writings of Sigmund Freud. New York: The Modern library, 1938.
- Freud, Sigmund, and James Strachey. Beyond the Pleasure Principle. New ed. New York: Norton, 1989.
- Fröbel, Friedrich, and W. N. Hailmann. The Education of Man. New York: Appleton-Century, 1885.
- Frisby, David. Fragments of Modernity: Theories of Modernity in the Work of Simmel, Kracauer and Benjamin. Cambridge: Polity, 1985.
- Frisch, Max. Homo Faber: A Report. New York: Harcourt Brace Jovanovich, 1959.
- Fuchs, Georg. Die Schaubühne Der Zukunft. Das Theater; Bd. 15. Berlin: Schuster & Loeffler, 1905.
- Funke, Gerhard. Phenomenology, Metaphysics or Method? Athens: Ohio University Press, 1987.
- Fusco, Coco. Corpus Delecti: Performance Art of the Americas. London; New York: Routledge, 2000.
- . The Bodies That Were Not Ours: And Other Writings. London; New York: Routledge, 2001.
- George, David. "Performance Epistemology", *Performance Research* Vol. 1: No. 1., 1996.
- Gibbons, Michael. The New Production of Knowledge: The Dynamics of Science and Research in Contemporary Societies. London; Thousand Oaks, Calif.: SAGE Publications, 1994.
- Gibson, William. Neuromancer. New York: Ace Books, 1984.
- Giles, Steve. Theorizing Modernism: Essays in Critical Theory. London; New York:

- 
- Routledge, 1993.
- Gillies, Donald. Artificial Intelligence and Scientific Method. Oxford, England: Oxford University Press, 1996.
- Gilroy, Paul. The Black Atlantic: Modernity and Double Consciousness. London; New York: Verso, 1993.
- . Against Race: Imagining Political Culture Beyond the Color Line. Cambridge, Mass.: Belknap Press of Harvard University Press, 2000.
- Gleick, James. Chaos: Making a New Science. New York, N.Y.: Viking, 1987.
- Glinsky, Albert. Theremin: Ether Music and Espionage. Urbana: University of Illinois Press, 2000.
- Gogroff-Voorhees, Andrea. Defining Modernism: Baudelaire and Nietzsche on Romanticism, Modernity, Decadence, and Wagner. New York: P. Lang, 1999.
- Goldberg, Ken. The Robot in the Garden: Telerobotics and Telepistemology in the Age of the Internet. Cambridge, Mass.: MIT Press, 2000.
- Goldberg, RoseLee. Performance: Live Art since 1960. New York: Harry N. Abrams Publishers, 1998.
- . Performance Art: From Futurism to the Present. Rev. & expanded ed. New York: Thames & Hudson, 2001.
- Goldberg, Ken, and Roland Siegwart. Beyond Webcams: An Introduction to Online Robots. Cambridge, Mass.: MIT Press, 2002.
- Goldstine, Herman Heine. The Computer from Pascal to Von Neumann. Princeton, N.J.: Princeton University Press, 1972.
- Gorman, Peter. Pythagoras, a Life. London; Boston: Routledge & K. Paul, 1979.
- Goulsh, Matthew. 39 Microlectures: In Proximity of Performance. London; New York: Routledge, 2000.
- Gómez-Peña, Guillermo. Warrior for Gringostroika: Essays, Performance Texts, and Poetry. St. Paul, Minn.: Graywolf Press, 1993.
- Gómez-Peña, Guillermo, Enrique Chagoya, and Felicia Rice. Codex Espangliensis: From Columbus to the Border Patrol. San Francisco: City Lights Books, 2000.
- Gray, Judith Anne, and National Dance Association. Dance Technology: Current Applications and Future Trends. Reston, Va.: The Association, 1989.
- Gray, Chris Hables, Heidi J. Figueroa-Sarriera, and Steven Mentor. The Cyborg Handbook. New York: Routledge, 1995.
- Gray, J. O., D. G. Caldwell, and Institution of Electrical Engineers. Advanced Robotics & Intelligent Machines. London: Institution of Electrical Engineers, 1996.
- Gropius, W (Ed). The Theater of the Bauhaus. Middletown, Conn.: Wesleyan University Press, 1961.
- Grossmann, Reinhardt. Structure of Mind. Madison,: U. of Wisconsin P., 1965.
- Grzanic, Marina, Stelarc, and International Festival of Computer Arts. Stelarc: Political Prosthesis and Knowledge of the Body = Politicna Proteza in Vednost Telesa. Ljubljana, Slovenia: MASKA and MKC, 2002.
- Guattari, Félix, and Gary Genosko. The Guattari Reader. Blackwell Readers. Cambridge, Mass.: Blackwell Publishers, 1996.
- Gurdjieff, Georges Ivanovitch. All and Everything: Ten Books, in Three Series, of Which This Is the First Series. London: Routledge & Kegan Paul, 1950.
- . Beelzebub's Tales to his Grandson London: Routledge & Kegan Paul, 1950.
- Halberstam, Judith, and Ira Livingston. Posthuman Bodies. Bloomington; Indianapolis Ind.: Indiana University Press, 1995.



- 
- Haraway, Donna Jeanne. Simians, Cyborgs, and Women: The Reinvention of Nature. London: Free Association Books, 1991.
- Harris, Jay. How the Brain Talks to Itself: A Clinical Primer of Psychotherapeutic Neuroscience. New York; London: Haworth, 1998.
- Hart, Leslie A. How the Brain Works: A New Understanding of Human Learning, Emotion, and Thinking. New York: Basic Books, 1975.
- Haugeland, John. Mind Design II: Philosophy, Psychology, Artificial Intelligence. Rev. and enl. ed. Cambridge, Mass.; London: MIT Press, 1997.
- Hawkes, Terence. Structuralism and Semiotics. London: Routledge, 1991.
- Hawking, S. W. A Brief History of Time. Updated and expanded tenth anniversary ed. New York: Bantam Books, 1998.
- Hayles, N. Katherine. How We Became Posthuman: Virtual Bodies in Cybernetics, Literature, and Informatics. Chicago, Ill.: University of Chicago Press, 1999.
- Heidegger, Martin, and Werner Brock. Existence and Being. 2d ed. London: Vision, 1956.
- Heidegger, Martin. Being and Time. Oxford: Blackwell, 1962.
- . The Basic Problems of Phenomenology. Rev. ed. Bloomington: Indiana University Press, 1988.
- . The Concept of Time. English-German ed. Oxford, UK; Cambridge, Mass.: B. Blackwell, 1992.
- . Introduction to Metaphysics. New Haven, CT: Yale University Press, 2000.
- Heim, Michael. The Metaphysics of Virtual Reality. New York; Oxford: Oxford University Press, 1993.
- Helsel, Sandra K., and Judith Paris Roth. Virtual Reality: Theory, Practice, and Promise. Westport; London: Meckler, 1991.
- Hermes, and Walter Scott. Hermetica: The Ancient Greek and Latin Writings Which Contain Religious or Philosophic Teachings Ascribed to Hermes Trismegistus. 4 vols. Boston; London: Shambhala, 1985.
- Hershman-Leeson, Lynn. Clicking In: Hot Links to a Digital Culture. Seattle: Bay Press, 1996.
- Hinton, John Michael. Experiences: An Inquiry into Some Ambiguities. Oxford: Clarendon Press, 1973.
- Hochman, Elaine S. Bauhaus: Crucible of Modernism. 1st ed. New York: Fromm International, 1997.
- Hodges, Andrew. Alan Turing: The Enigma. London: Burnett Books, 1983.
- Hodgson, John, and Valerie Monthland Preston-Dunlop. Rudolf Laban: An Introduction to His Work & Influence. Plymouth: Northcote, 1990.
- Hofstadter, Douglas R. Gödel, Escher, Bach: An Eternal Golden Braid. New York: Basic Books, 1979.
- Horn, David G. Social Bodies: Science, Reproduction, and Italian Modernity. Princeton, N.J.: Princeton University Press, 1994.
- Hughes-Freeland, Felicia, and Association of Social Anthropologists of the Commonwealth. Conference. Ritual, Performance, Media. London; New York: Routledge, 1998.
- Hultén, Karl Gunnar Pontus. Futurism & Futurisms. New York: Abbeville Press, 1986.
- Hume, David, David Fate Norton, and Mary J. Norton. A Treatise of Human Nature. Oxford; New York: Oxford University Press, 2000.
- Huntington, Patricia J. Ecstatic Subjects, Utopia, and Recognition: Kristeva,

- 
- Heidegger, Irigaray. Albany, N.Y.: State University of New York Press, 1998.
- Husserl, Edmund, and William Ralph Boyce Gibson. Ideas: General Introduction to Pure Phenomenology. London, New York: G. Allen & Unwin Ltd.; The Macmillan company, 1931.
- Husserl, Edmund. Cartesian Meditations: An Introduction to Phenomenology. The Hague: M. Nijhoff, 1960.
- . Phenomenology of Internal Time-Consciousness. Indiana U.P., 1964.
- . Phenomenology and the Crisis of Philosophy: Philosophy as Rigorous Science, and Philosophy and the Crisis of European Man. New York: Harper-Row, 1965.
- . Cartesian Meditations: An Introduction to Phenomenology. The Hague: M. Nijhoff, 1966.
- . Ideas: General Introduction to Pure Phenomenology. London: Allen & Unwin, 1969.
- . Phenomenology and the Foundations of the Sciences. Hague; Boston, Hingham, MA: M. Nijhoff Publishers; distributions for the U.S. and Canada Kluwer Boston, 1980.
- , The Idea of Phenomenology. Dordrecht; Boston: Kluwer Academic, 1999.
- Husserl, Edmund, et al. Husserl at the Limits of Phenomenology: Including Texts by Edmund Husserl. Evanston, Ill.: Northwestern University Press, 2002.
- Hutchby, Ian, and Robin Wooffitt. Conversation Analysis: Principles, Practices and Applications. Malden, Mass.: Polity Press, 1998.
- Irigaray, Luce. This Sex Which Is Not One. Ithaca, N.Y.: Cornell University Press, 1985.
- Jackendoff, Ray. Consciousness and the Computational Mind. Cambridge, Mass.: MIT Press, 1987.
- Jacob, Pierre. What Minds Can Do: Intentionality in a Non-Intentional World. Cambridge; New York: Cambridge University Press, 1997.
- James, William. The Varieties of Religious Experience: A Study in Human Nature Edited with an introduction by Martin E. Marty. Harmondsworth, Middlesex, England; New York, N.Y.: Penguin Books, 1982.
- Jáuregui, José Antonio. The Emotional Computer. Oxford, UK; Cambridge, Mass.: Blackwell Publishers; B. Blackwell, 1995.
- Jervis, John. Transgressing the Modern: Explorations in the Western Experience of Otherness. Oxford; Malden, MA.: Blackwell Publishers, 1999.
- Jones, Steve. The Language of the Genes: Biology, History and the Evolutionary Future. Rev. ed. London: Flamingo, 2000.
- Jongeneel, Else, and Valerie K. Robillard. Pictures into Words: Theoretical and Descriptive Approaches to Ekphrasis. Amsterdam: VU University Press, 1998.
- Jordan, Stephanie. Striding Out: Aspects of Contemporary and New Dance in Britain. London: Dance Books, 1992.
- , (ed). Preservation Politics: Dance Revived, Reconstructed, Remade. London: Dance, 2001.
- Jowitt, Deborah. Time and the Dancing Image. New York: W. Morrow, 1988.
- Jung, C. G., Marie Louise von Franz, and John Freeman. Man and His Symbols. London: Aldus 1964, 1964.
- Jung, C. G. Aion: Researches into the Phenomenology of the Self. 2d ed. Princeton, N.J.: Princeton University Press, 1969.
- . Aion: Researches into the Phenomenology of the Self. 2d ed. Princeton, N.J.:



- 
- Princeton University Press, 1969.
- . The Archetypes and the Collective Unconscious.. 2d ed. Princeton, N.J.: Princeton University Press, 1969.
- Jung, C. G., and National Institute of Mental Health (U.S.). Abstracts of the Collected Works of C.G. Jung. Rockville, Md.: National Institute of Mental Health, 1978.
- Kafka, Franz. Erzählungen. Frankfurt a.M.: S. Fischer, 1967.
- Kahn, Charles H. Pythagoras and the Pythagoreans: A Brief History. Indianapolis, IN: Hackett Pub., 2001.
- Kaku, Michio. Visions: How Science Will Revolutionize the 21st Century. New York: Anchor Books, 1997.
- . Visions: How Science Will Revolutionize the 21st Century. New York: Anchor Books, 1997.
- Kandinsky, Wassily, Michael Sadleir, and Francis Golffing. Concerning the Spiritual in Art, and Painting in Particular, 1912. New York,: Wittenborn Schultz, 1947.
- Kandinsky, Wassily, and Hilla Rebay. Point and Line to Plane. New York: Dover Publications, 1979.
- Kelly, Kevin. Out of Control: The New Biology of Machines. London: Fourth Estate,, 1994.
- Kennedy, Barbara M., and David Bell. The Cybercultures Reader. London New York: Routledge, 2000.
- Kenny, Anthony John Patrick. Descartes: A Study of His Philosophy. Bristol: Thoemmes Press, 1968, 1993.
- Kirby, Michael, and Victoria Nes Kirby. Futurist Performance: With Manifestos and Playscripts. New York: Dutton,, 1971.
- Klein, Julie. Transdisciplinarity: Joint Problem-Solving among Science, Technology and Society. Basel: Birkhauser Verlag, 2001.
- Kozel, Susan. (1999) "Ghostcatching": Archis: Architecture – City – *Visual Culture* (Rotterdam), pp70-74 and *Dance Theatre Journal* vol. 15, no 2.
- , "Marionettes and Dancers: Dance and Digital Technologies." *Archis: Architecture - City - Visual Culture*. No 61. (Rotterdam), 1998a.
- , "Multi-Medea: Feminist Performance Using Multimedia Technologies". The Routledge Reader in Gender and Performance, ed. L. Goodman & J. de Gay. London and New York: Routledge, 1998b.
- , "Spacemaking: Experiences of a Virtual Body" (reprint). The Routledge Reader in Dance Studies, ed. A. Carter. London and New York: Routledge, 1998c.
- , "The Carbon Unit in the Silicon Domain: More Thoughts on Dance and Digital Technologies". *Writings on Dance* 17, 1997.
- , "As Vision Becomes Gesture" Unpublished PhD. University of Essex, 1994.
- Kristeva, Julia. Revolution in Poetic Language. New York; Guildford: Columbia University Press, 1984.
- , Language—the Unknown: An Initiation into Linguistics. New York: Columbia University Press, 1989.
- Kroker, Arthur. Spasm: Virtual Reality, Android Music, and Electric Flesh. New York: St. Martin's Press, 1993.
- Krueger, Myron W. Artificial Reality II. 2nd ed. Reading, Mass.; Wokingham: Addison-Wesley, 1991.
- Kugler, Paul. The Alchemy of Discourse: An Archetypal Approach to Language.

- 
- Lewisburg Pa.: Bucknell University Press, 1982.
- Kuhn, Thomas S. The Structure of Scientific Revolutions. 3rd ed. Chicago, IL: University of Chicago Press, 1996.
- Kurzweil, Ray. The Age of Spiritual Machines: When Computers Exceed Human Intelligence. New York: Viking, 1999.
- Laban, Rudolf von. Choreutics. London: Macdonald & Evans, 1966.
- Laban, Rudolf, and F.C. Lawrence. Effort London: Macdonald & Evans, 1947.
- Langer, Monika, and Maurice Merleau-Ponty. Merleau-Ponty's Phenomenology of Perception: A Guide and Commentary. Basingstoke, Hampshire: Macmillan, 1989.
- Langton, C.G. "Artificial Life" in Artificial Life Santa Fe Institute Studies in the Sciences of Complexity, Vol. VI. ed. Addison-Wesley, Redwood City, California (1989).
- Law, Alma H., and Mel Gordon. Meyerhold, Eisenstein and Biomechanics: Actor Training in Revolutionary Russia. Jefferson, N.C.: London: McFarland,, 1996.
- Lawlor, Robert. Sacred Geometry: Philosophy and Practice. London: Thames and Hudson,, 1982.
- Lawson, Joan. A History of Ballet and Its Makers. London: Dance Books, 1973.
- Layson, June, and Janet Adshead-Lansdale. Dance History: An Introduction. 2nd ed. London; New York: Routledge, 1994.
- Layzer, David. Cosmogenesis: The Growth of Order in the Universe. New York; Oxford: Oxford University Press, 1990.
- Leach, Robert. Vsevolod Meyerhold. Cambridge: Cambridge University Press, 1989.
- Lechte, John. Fifty Key Contemporary Thinkers: From Structuralism to Postmodernity. London: Routledge, 1994.
- Leder, Drew. The Absent Body. Chicago: University of Chicago Press, 1990.
- Lefebvre, Henri. The Production of Space. Oxford, OX, UK; Cambridge, Mass.: Blackwell, 1991.
- Lenarcic, J., and F. Thomas. Advances in Robot Kinematics: Theory and Applications. Dordrecht; Boston: Kluwer Academic Publishers, 2002.
- Levi-Strauss, Claude. The Savage Mind. Chicago: University of Chicago Press, 1966.
- . The Raw and the Cooked. 1st U.S. ed. New York: Harper & Row, 1969.
- Lewin, Roger. Complexity: Life at the Edge of Chaos. 2nd ed. Chicago, Ill.: University of Chicago Press, 1999.
- Lista, Giovanni, and Susan Wise. Futurism. Paris: Terrail, 2001.
- Liverpool, Hollis Chalkdust. Rituals of Power and Rebellion: The Carnival Tradition in Trinidad and Tobago, 1763-1962. Chicago, IL.; Trinidad and Tobago: Research Associates School Times; Frontline Distribution, 2001.
- Loy, Mina, and Roger L. Conover. The Last Lunar Baedeker. Highlands, N.C.: Jargon Society, 1982.
- Lycan, William G. Mind and Cognition: A Reader. Oxford, UK; New York, NY: Basil Blackwell, 1990.
- Lyotard, Jean François. The Postmodern Condition: A Report on Knowledge. Minneapolis: University of Minnesota Press, 1984.
- . Phenomenology. Albany: State University of New York Press, 1991.
- Maboungou, Zab. "Where Is Your 'One'", Unpublished Essay Delivered at the Beauty and Civilisation Conference, Montreal. (1997a).
- , "The Art of Improvisation in African Dance". Revue Noire, Paris, France, June, July, August, 1997b.



- 
- Macann, Christopher E. Four Phenomenological Philosophers: Husserl, Heidegger, Sartre, Merleau-Ponty. London; New York: Routledge, 1993.
- MacCurdy, E & Leonardo, da Vinci. The Notebooks of Leonardo Da Vinci. London: J. Cape, 1977.
- Maletic, Vera. Body, Space, Expression: The Development of Rudolf Laban's Movement and Dance Concepts. Berlin; New York: Mouton de Gruyter, 1987.
- Manning, Susan. Ecstasy and the Demon: Feminism and Nationalism in the Dances of Mary Wigman. Berkeley: University of California Press, 1993.
- Marek, Burt W. Archaeology of the Cinema. 1st American ed. New York: Harcourt Brace & World, 1965.
- Marinetti, Filippo Tommaso, and R. W. Flint. Let's Murder the Moonshine: Selected Writings. 1st ed. Los Angeles: Sun & Moon Press, 1991.
- Martin, John Joseph. The Modern Dance. Brooklyn: Dance Horizons, 1965.
- , Introduction to the Dance. Brooklyn: Dance Horizons, 1965.
- . America Dancing: The Background and Personalities of the Modern Dance. Brooklyn: Dance Horizons, 1968.
- Martin, Marianne W. Futurist Art and Theory 1909-1915. Oxford: Clarendon P., 1968.
- Martin, John Joseph. The Dance in Theory. Princeton, NJ: Princeton Book Co., 1989.
- Martin, Randy. Critical Moves: Dance Studies in Theory and Politics. Durham, NC: Duke University Press, 1998.
- Masters, Brian. Killing for Company: The Case of Dennis Nilsen. London: Cape, 1985.
- Maturana, Humberto, R., and Francisco J. Varela. The Tree of Knowledge: The Biological Roots of Human Understanding. Rev. ed. Boston, New York: Shambhala; Distributed in the U.S. by Random House, 1992.
- . The Tree of Knowledge: The Biological Roots of Human Understanding. Rev. ed. Boston New York: Shambhala; Distributed in the U.S. by Random House, 1992.
- Mazlish, Bruce. The Fourth Discontinuity: The Co-Evolution of Humans and Machines. New Haven: Yale University Press, 1993.
- McFee, Graham. Understanding Dance. New York: Routledge, 1992.
- McLuhan, Marshall. Understanding Media: The Extensions of Man. 1st MIT Press ed. Cambridge, Mass.: MIT Press, 1994.
- Mellor, D. H. Ways of Communicating. Cambridge England; New York: Cambridge University Press, 1990.
- Merleau-Ponty, Maurice. Phenomenology of Perception. International Library of Philosophy and Scientific Method. New York: Humanities Press, 1962.
- . Phenomenology of Perception. 1st Indian ed. Delhi: Motilal Banarsidass, 1996.
- . Consciousness and the Acquisition of Language. Evanston: Northwestern University Press, 1973.
- Merleau-Ponty, Maurice, and Claude Lefort. The Visible and the Invisible: Followed by Working Notes. Evanston Ill.: Northwestern University Press, 1968.
- Merleau-Ponty, Maurice, and Alden L. Fisher. The Essential Writings of Merleau-Ponty. New York: Harcourt Brace & World, 1969.
- Merleau-Ponty, Maurice, Andrew G. Bjelland, and Patrick Burke. The Incarnate Subject: Malebranche, Biran, and Bergson on the Union of Body and Soul. Amherst, N.Y.: Humanity Books, 2001.
- Messer, David J. The Development of Communication: From Social Interaction to

- 
- Language. Chichester, Eng.; New York: Wiley, 1994.
- Messiaen, Olivier. The Technique of My Musical Language. Paris: A. Leduc, 1956.
- Miller, Arthur. Arthur Miller: Eight Plays. Garden City, N.Y.: Nelson Doubleday, 1981.
- Minsky, Marvin Lee. The Society of Mind. New York, N.Y.: Simon and Schuster, 1986.
- Mirzoeff, Nicholas. Diaspora and Visual Culture: Representing Africans and Jews. London; New York: Routledge, 2000.
- Mitchell, William J., and NetLibrary Inc. City of Bits Space, Place, and the Infobahn. Cambridge, Mass.: MIT Press, 1995.
- Mitkov, Ruslan. The Oxford Handbook of Computational Linguistics. Oxford; New York: Oxford University Press, 2003.
- Mock, Roberta. Performing Processes. Oxford: Intellect, 2000.
- Mohanty, Jitendranath. Phenomenology: Between Essentialism and Transcendental Philosophy. Evanston, Ill.: Northwestern University Press, 1997.
- Moore, F. C. T. Bergson: Thinking Backwards. Cambridge; New York: Cambridge University Press, 1996.
- Moran, Dermot, and Timothy Mooney. Phenomenology Reader. New York: Routledge, 2002.
- Moravec, Hans P. Robot: Mere Machine to Transcendent Mind. New York; Oxford: Oxford University Press, 1999.
- Mosco, Vincent. The Digital Sublime: Myth, Power, and Cyberspace. Cambridge, Mass.: MIT Press, 2004.
- Moser, Mary Anne, Douglas MacLeod, and Banff Centre for the Arts. Immersed in Technology: Art and Virtual Environments. Cambridge, Mass.: MIT Press, 1996.
- Naylor, Gillian. The Bauhaus Reassessed: Sources and Design Theory. London: Herbert Press, 1985.
- Ouspensky, P. D. In Search of the Miraculous: Fragments of an Unknown Teaching. London: Routledge & Kegan Paul, 1983.
- Pagels, Heinz R. The Dreams of Reason: The Computer and the Rise of the Sciences of Complexity. New York: Simon and Schuster, 1988.
- Partsch-Bergsohn, Isa. Modern Dance in Germany and the United States: Cross Currents and Influences. Chur; Philadelphia: Harwood Academic Publishers, 1993.
- Partsch-Bergsohn, Isa, and Harold Bergsohn. The Makers of Modern Dance in Germany: Rudolph Laban, Mary Wigman, Kurt Jooss. Hightstown, NJ: Princeton Book Co., 2003.
- Pavis, Patrice. Theatre at the Crossroads of Culture. London; New York: Routledge, 1992.
- . The Intercultural Performance Reader. London; New York: Routledge, 1996.
- . Analyzing Performance: Theater, Dance, and Film. Ann Arbor: University of Michigan Press, 2003.
- Penrose, Roger. The Emperor's New Mind Concerning Computers, Minds, and the Laws of Physics. Oxford; New York: Oxford University Press, 1989.
- . Shadows of the Mind: A Search for the Missing Science of Consciousness. Oxford; New York: Oxford University Press, 1994.
- Pepperell, Robert. The Post-Human Condition. Oxford, England: Intellect, 1995.
- . The Posthuman Condition: Consciousness Beyond the Brain. New ed. Bristol



- 
- Eng.; Portland, Or.: Intellect, 2003.
- Perloff, Marjorie. The Futurist Moment: Avant-Garde, Avant Guerre, and the Language of Rupture. Chicago: University of Chicago Press, 1986.
- Petitot, Jean. Naturalizing Phenomenology: Issues in Contemporary Phenomenology and Cognitive Science. Stanford, Calif.: Stanford University Press, 1999.
- Piaget, Jean. Behavior and Evolution. 1st American ed. New York: Pantheon Books, 1978.
- Pinker, Steven, and Jacques Mehler. Connections and Symbols. Bradford Book. Cambridge, Mass.: MIT Press, 1988.
- Pinker, Steven. How the Mind Works. London: Alan Lane, 1998.
- Plant, Sadie. Zeros + Ones: Digital Women + the New Technoculture. London: Fourth Estate, 1997.
- Plato, G. R. F. Ferrari, and Tom Griffith. The Republic. New York: Cambridge University Press, 2000.
- Polanyi, Michael. Personal Knowledge: Towards a Post-Critical Philosophy. London: Routledge, 1998.
- Popper, Karl Raimund. The Logic of Scientific Discovery. London: Routledge, 1992.
- . Objective Knowledge: An Evolutionary Approach. Rev. ed. Oxford: Clarendon Press, 1992.
- Preston-Dunlop, Valerie Monthland. Rudolf Laban: An Extraordinary Life. London: Dance Books, 1998.
- Price, Carolyn. Functions in Mind: A Theory of Intentional Content. Oxford; New York: Oxford University Press, 2001.
- Prigogine, I., and Isabelle Stengers. Order out of Chaos: Man's New Dialogue with Nature. New York, N.Y.: Bantam Books, 1984.
- Putnam, Hilary. Representation and Reality. Cambridge, Mass.: MIT Press, 1988.
- Pylyshyn, Zenon W. Computation and Cognition: Toward a Foundation for Cognitive Science. Cambridge, Mass.: MIT Press, 1984.
- Rheingold, Howard. Virtual Reality. 1st Touchstone ed. New York, N.Y.: Simon & Schuster, 1992.
- Rodis-Lewis, Geneviève. Descartes: His Life and Thought. Ithaca, N.Y.; London: Cornell University Press, 1998.
- Rogers-Lafferty, Sarah, Heidi Gilpin, and Brian Massumi. Body Mécanique: Exhibition Catalogue; Artistic Explorations of Digital Realms. Columbus, Ohio: Wexner Center for the Arts the Ohio State University, 1998.
- Rowland, Anna. Bauhaus Source Book. Oxford: Phaidon, 1990.
- Ryle, Gilbert. The Concept of Mind. New York: Barnes & Noble, 1963.
- Sartre, Jean Paul. Being and Nothingness; an Essay on Phenomenological Ontology. New York: Philosophical Library, 1956.
- . Essays in Aesthetics. New York: Philosophical Library, 1963.
- . Colonialism and Neocolonialism. London; New York: Routledge, 2001.
- Sartre, Jean Paul, and Wade Baskin. Essays in Existentialism. Secaucus, N. J.: Citadel Press, 1977.
- Sartre, Jean Paul, and Stephen Priest. Jean-Paul Sartre; Basic Writings. London; New York: Routledge, 2001.
- Saussure, Ferdinand de, et al. Course in General Linguistics. 3rd ed. London: Duckworth, 1983.
- Schechner, Richard. The Future of Ritual: Writings on Culture and Performance. London; New York: Routledge, 1993.

- 
- . Performance Studies: An Introduction. London; New York: Routledge, 2002.
- . Performance Theory. Routledge Classics. Rev and expanded ed. London; New York: Routledge, 2003.
- Scheper, Dirk. Oskar Schlemmer: The Triadic Ballet. Akademie Der Künste; Documentation 5. Berlin: Druckhaus Hentrich, 1985.
- Scheyer, Ernst, and Foundation Dance Perspectives. The Shapes of Space: The Art of Mary Wigman and Oskar Schlemmer. Dance Perspectives; 41. New York: Dance Perspectives Foundation, 1970.
- Schlemmer, Oskar. The Letters and Diaries of Oskar Schlemmer. Middletown, Conn.: Wesleyan University Press, 1972.
- Schlemmer, Oskar, et al. Oskar Schlemmer: Tanz, Theater, Bühne: Vortragsreihe Zur Ausstellung. Schriftenreihe Der Kunsthalle Wien. Klagenfurt: Ritter Verlag, 1997.
- Scholz, R.W., Thompson Klein, J., Grossenbacher-Mansuy, W., Häberli, R., Bill, A., and M. (Eds.) & Welte. Joint Problem-Solving among Science, Technology and Society. Zürich: Haffmans Sachbuch Verlag AG, 2001.
- Scott, Alwyn. Stairway to the Mind: The Controversial New Science of Consciousness. New York: Copernicus, 1995.
- Searle, John R. Minds, Brains, and Science. Cambridge, Mass.: Harvard University Press, 1984.
- Searle, John R. The Rediscovery of the Mind. Cambridge, Mass.: MIT Press, 1992.
- Servos, Norbert. Pina Bausch-Wuppertal Dance Theater, or, The Art of Training a Goldfish: Excursions into Dance Gert Weigelt (photography); translated from the German by Patricia Stadié. Köln: Ballett-Bühnen-Verlag, 1984.
- Shear, J. Explaining Consciousness: The "Hard Problem". Cambridge, Mass.; London: MIT Press, 1997.
- Sheets-Johnstone, Maxine. The Phenomenology of Dance. Dance. New York: Books for Libraries, 1980.
- . Illuminating Dance: Philosophical Explorations. Lewisburg, N.J.: Bucknell University Press, 1984.
- . Giving the Body Its Due. Albany: State University of New York Press, 1992.
- . The Roots of Power: Animate Form and Gendered Bodies. Chicago: Open Court, 1994.
- . The Primacy of Movement. Amsterdam; Philadelphia: John Benjamins Pub., 1999.
- Shelley, Mary Wollstonecraft, Charles E. Robinson, and Betty T. Bennett. The Mary Shelley Reader: Containing Frankenstein, Mathilda, Tales and Stories, Essays and Reviews, and Letters. New York: Oxford University Press, 1990.
- Shelley, Mary Wollstonecraft, David Lorne Macdonald, and Kathleen Scherf. Frankenstein, or, the Modern Prometheus. Peterborough, Ont.: Broadview Press, 1999.
- . Frankenstein, or, the Modern Prometheus. Peterborough, Ont.; Fairwater: Broadview, 1994.
- Simon, Herbert Alexander. The Sciences of the Artificial. 3rd ed. Cambridge, Mass.: MIT Press, 1996.
- Singer, Dorothea Waley, and Giordano Bruno. Giordano Bruno: His Life and Thought. New York: Greenwood Press, 1968.
- Smith, Jonathan Z. To Take Place: Toward Theory in Ritual. Chicago: University of Chicago Press, 1987.



- 
- Smith, A. William, National Dance Association and University of Wisconsin--Madison. School of Education. Dance Program. Dance and Technology I: Moving toward the Future: Proceedings of the First Annual Conference, 28 February to 1 March 1992, University of Wisconsin, Madison. Westerville, OH: Fullhouse Pub., 1992.
- Smith, A. William, National Dance Association and York University (Toronto Ont.). Dance and Technology III: Transcending Boundaries: Proceedings of the Third Annual Conference, 18-21 May 1995, York University, (North York) Toronto, Ontario, Canada. Columbus. Ohio: Fullhouse Pub., 1995.
- Smith, Anna. Julia Kristeva: Readings of Exile and Estrangement. London: Macmillan, 1996., 1996.
- Smith, Hazel, and R. T. Dean. Improvisation, Hypermedia, and the Arts since 1945. Amsterdam, The Netherlands: Harwood Academic Publishers, 1997.
- Smith, Anne-Marie. Julia Kristeva: Speaking the Unspeakable. London; Sterling, Va.: Pluto Press, 1998.
- Sontag, Susan. Aids and Its Metaphors. 1st ed. New York, N.Y.: Farrar Straus and Giroux, 1989.
- Sorlin, Pierre. Mass-Media. Key Ideas. London; New York: Routledge, 1994.
- Soussloff, C. & Franko, M. "Visual and Performance Studies, a New History of Interdisciplinarity." Social Text 73, Vol. 20, No. 4 (Winter 2002) 29-45. Vol. 20, No. 4. Winter 2002 (2002): 29-45.
- Sparshott, Francis Edward. A Measured Pace: Toward a Philosophical Understanding of the Arts of Dance. Toronto; Buffalo: University of Toronto Press, 1995.
- Spencer, Herbert, and Robert L. Carneiro. The Evolution of Society: Selections from Herbert Spencer's Principles of Sociology. Chicago: University of Chicago Press, 1967.
- Spiegelberg, Herbert. Doing Phenomenology: Essays on and in Phenomenology. The Hague: Nijhoff, 1975.
- . The Context of the Phenomenological Movement. The Hague: M. Nijhoff, 1981.
- . The Phenomenological Movement: A Historical Introduction. 3rd rev. and enl. ed. Hague: Nijhoff, 1982.
- Stace, W. T. Mysticism and Philosophy. [1st ed. Philadelphia: Lippincott, 1960.
- Steinman, Louise. The Knowing Body: Elements of Contemporary Performance & Dance. 1st ed. Boston [New York]: Shambhala; Distributed by Random House, 1986.
- Stocker, Gerfried, and Christine Schöpf. Fleshfactor: Informationsmaschine Mensch. Wien; New York: Springer, 1997.
- Stone, Allucquère Rosanne. The War of Desire and Technology at the Close of the Mechanical Age. Cambridge, Mass.: MIT Press, 1995.
- Storr, Anthony. Music and the Mind. London: HarperCollins 1992, 1992.
- Swade, Doron. The Cogwheel Brain: Charles Babbage and the Quest to Build the First. London: Little, Brown, 2000.
- Tarski, Alfred, and J. H. Woodger. Logic, Semantics, Metamathematics: Papers from 1923 to 1938. Oxford: Clarendon Press 1956, 1956.
- Taylor, Charles. Human Agency and Language. Cambridge: Cambridge University Press, 1985.
- Taylor, Frederick. The Principles of Scientific Management. New York; London: Harper & brothers, 1911.
- Thagard, Paul. Conceptual Revolutions. Princeton, N.J.: Princeton University Press,

- 1992.
- . Mind Readings: Introductory Selections on Cognitive Science. Cambridge, Mass.: MIT Press, 1998.
- Thomas, Helen. Dance, Modernity and Culture: Explorations in the Sociology of Dance. London: Routledge, 1995.
- Todes, Samuel. Body and World. Cambridge, Mass.: MIT Press, 2001.
- Töpfer, Karl Eric. Empire of Ecstasy: Nudity and Movement in German Body Culture, 1910-1935. Weimar and Now; Berkeley, Calif.; London: University of California Press, 1997.
- Turing, A. "Computing Machinery and Intelligence". MIND [the Journal of the Mind Association] vol. LIX.no. 236 (1950): pp. 433-60).
- Turner, David H. Australian Aboriginal Social Organization. Atlantic Highlands, N.J.: Humanities Press, 1980.
- Turner, Victor Witter. The Anthropology of Performance. New York: PAJ Publications, 1986.
- Turner, Bryan S. The Body and Society: Explorations in Social Theory. 2nd ed. London; Thousand Oaks, CA: Sage Publications, 1996.
- Varela, Francisco J., Evan Thompson, and Eleanor Rosch. The Embodied Mind: Cognitive Science and Human Experience. 1st MIT Press paperback ed. Cambridge, Mass.: MIT Press, 1993.
- Varela, F.J. & Shear, J. "First-Person Methodologies: What, Why, How?" Journal of Consciousness Studies Journal of Consciousness Studies 6.No. 2-3 (1999): pp. 1-14.
- Velmans, Max. Understanding Consciousness. London: Routledge, 2000.
- Vitz, Paul C., and Arnold B. Glimcher. Modern Art and Modern Science: The Parallel Analysis of Vision. New York; Eastbourne: Praeger, 1984.
- Von Neumann, John, Paul M. Churchland, and Patricia Smith Churchland. The Computer and the Brain. 2nd ed. New Haven, CT: Yale University Press, 2000.
- Vygotsky, L. S., and Alex Kozulin. Thought and Language. Translation newly rev. and edited / ed. Cambridge, Mass.: MIT Press, 1986.
- Waldrop, M. Mitchell. Complexity: The Emerging Science at the Edge of Order and Chaos. New York: Simon & Schuster, 1992.
- Walens, Stanley. Feasting with Cannibals: An Essay on Kwakiutl Cosmology. Princeton, N.J.: Princeton University Press, 1981.
- Walton, Douglas N. Argument Structure: A Pragmatic Theory. Toronto; Buffalo: University of Toronto Press, 1996.
- Weizenbaum, Joseph. Computer Power and Human Reason: From Judgment to Calculation. Harmondsworth: Penguin, 1984.
- Welton, Donn. Body and Flesh: A Philosophical Reader. Malden, Mass.: Blackwell Publishers, 1998.
- . The Body: Classic and Contemporary Readings. Malden, Mass.: Blackwell, 1999.
- Wenger, Susanne, and Gert Chesi. A Life with the Gods in Their Yoruba Homeland. Worg, Austria: Perlinger Verlag, 1983.
- Wiener, Norbert. "Cybernetics". Scientific American 179: 14-19, 1948.
- . The Human Use of Human Beings: Cybernetics and Society. 2d ed. Garden City, N.Y.: Doubleday, 1954.
- . Cybernetics; or, Control and Communication in the Animal and the Machine. 2d ed. New York: M.I.T. Press, 1961.



- 
- Wood, John. The Virtual Embodied: Presence/Practice/Technology. London; New York: Routledge, 1998.
- Woods, Tim. Beginning Postmodernism. Manchester; New York: Manchester University Press, 1999.
- Wolf, Virginia, and J. H. Stape. Orlando: A Biography. Oxford: Published for the Shakespeare Head Press by Blackwell, 1998.
- Worton, Michael, and Judith Still. Intertextuality: Theories and Practice. Manchester; New York, New York, NY: Manchester University Press; Distributed exclusively in the USA and Canada by St Martin's Press, 1990.
- Zane, Arnie, et al. Continuous Replay: The Photographs of Arnie Zane. Cambridge, Mass. Riverside, Calif.: MIT Press; UCR/California Museum of Photography University of California, 1999.
- Zohar, Danah, and I. N. Marshall. The Quantum Self: Human Nature and Consciousness Defined by the New Physics. 1st ed. New York: Morrow, 1990.
- . The Quantum Society: Mind, Physics and a New Social Vision. London: Bloomsbury Pub., 1993.
- Zuckerklund, Victor. Sound and Symbol. [Princeton, N.J.]: Princeton University Press, 1969.
- . Man the Musician: Sound and Symbol, Volume Two. Princeton: Princeton University Press, 1973.