



Wragge-Morley, R. T., Herrmann, G., Barber, P., & Burgess, S. C. (2015). Gradient and Mass Estimation from CAN Based Data for a Light Passenger Car. *SAE International Journal of Passenger Cars- Mechanical Systems*, 8(1), 137-145. 10.4271/2015-01-0201

Peer reviewed version

Link to published version (if available):
[10.4271/2015-01-0201](http://dx.doi.org/10.4271/2015-01-0201)

[Link to publication record in Explore Bristol Research](#)
PDF-document

University of Bristol - Explore Bristol Research

General rights

This document is made available in accordance with publisher policies. Please cite only the published version using the reference above. Full terms of use are available:
<http://www.bristol.ac.uk/pure/about/ebr-terms.html>

Take down policy

Explore Bristol Research is a digital archive and the intention is that deposited content should not be removed. However, if you believe that this version of the work breaches copyright law please contact open-access@bristol.ac.uk and include the following information in your message:

- Your contact details
- Bibliographic details for the item, including a URL
- An outline of the nature of the complaint

On receipt of your message the Open Access Team will immediately investigate your claim, make an initial judgement of the validity of the claim and, where appropriate, withdraw the item in question from public view.

Gradient and Mass Estimation from CAN based data for a light passenger car

Robert Wragge-Morley, Guido Herrmann, Stuart Burgess
University of Bristol

Phil Barber
Jaguar and Land Rover Research

Copyright © 2015 SAE International

Abstract

We present a method for the estimation of vehicle mass and road gradient for a light passenger vehicle. The estimation method uses information normally available on the vehicle CAN bus without the addition of extra sensors. A composite parameter estimation algorithm incorporating a nonlinear adaptive observer structure uses vehicle speed over ground and driving torque to estimate mass and road gradient. A system of filters is used to avoid deriving acceleration directly from wheel speed. In addition, a novel data fusion method makes use of the regressor structure to introduce information from other sensors in the vehicle. The dynamics of the additional sensors must be able to be parameterised using the same parameterisation as the complete vehicle system dynamics. In this case we make use of an Inertial Measurement Unit (IMU) which is part of the vehicle safety and Advanced Driver Assist Systems (ADAS). Therefore, a method using some filtering and supervisory logic is employed to give a sensible update behaviour for the vehicle mass estimation algorithm. The main function of the supervisor is to reject the mass estimate produced by unsuitable available data due to unmodelled loss forces. Good estimation results are obtained from data from a vehicle which was also fitted with some additional instrumentation including GPS sensors and a high quality IMU for scientific verification purposes.

1 Introduction

In the quest for increased vehicular functionality and autonomy, there is a requirement for more effective vehicle modelling in the context of control. Certain elements of a vehicle model may not be well known or easily determined by fitting inexpensive sensors to the vehicle system. Certain vehicle parameters are coupled mathematically by the vehicle dynamics so that sensor outputs include the influence of more than one vehicle or environmental parameter.

A pair of parameters to which this coupling applies are the focus of this paper, namely vehicle mass and road gradient. These are coupled by the Newtonian dynamics of the vehicle. Both are time varying from the vehicle's frame of reference, and both exhibit some dynamic behaviour, albeit with very different time scales and characteristics. Neither parameter is easy or especially inexpensive to measure directly in the context of current light duty passenger vehicle

practice, but their estimation from existing vehicle bus data is complicated by the influence of other aspects of vehicle dynamics.

In this paper, we present a new set of results that demonstrate the effectiveness of a novel regressor-based data-fusion method for tackling a real estimation problem. We introduce two methods of supervised output filtering on the mass estimate to improve its robustness to certain types of error. The first method identifies periods of convergence of the estimate on an appropriate value and rejects estimates during events likely to generate errors. The second method makes use of a Kalman Filter which is controlled by the same type of data-rejection supervision to smooth the output; this method makes use of the ease with which a simple noise model may be identified for the mass parameter estimate. Data collected from practical vehicular experiments with a light passenger vehicle as part of a series of vehicle dynamics tests supporting several automotive projects is processed offline to demonstrate the effectiveness of these novel methods.

We begin by presenting an overview of the current state of the art in vehicle mass and road gradient estimation and also the background to this particular piece of work in light of the other methods found in the literature. We will then examine the mathematical context for the problem. This will encompass the methods used for vehicle modelling, and the novel composite parameter estimation algorithm used at the core of the estimation method. The regressor data fusion method originally presented in [1] will then be reiterated in its latest form, as used for the work in this paper. The use of supervised output filtering to manage the mass estimate will then be presented and discussed along with results from experiments carried out using real vehicles.

2 A Brief Overview of the Current State of the Art in Vehicle Mass and Road Gradient Estimation

A considerable amount of effort has been made by academic and industrial researchers into the online estimation of vehicle parameters that are either prohibitively difficult or expensive to measure directly. The most usual approaches are to use estimation based on the Recursive Least Squares algorithm [2] [3][4] or Kalman Filtering [2][3][4] and many make use of data fusion from more than one source.

Vahidi *et al.*[5] make use of RLS methods to simultaneously estimate vehicle mass and road grade. Han *et al.*[6], Kim *et al.*[7] and Fathy *et al.*[8] among others have all used RLS methods to estimate vehicle mass, using various dynamics including lateral and roll dynamics. The extended RLS has been used to estimate a large number of vehicle parameters simultaneously in simulation by Bayani Khaknejad *et al.* [9] and expanded to include a total least squares approach to a similar problem by Rhode and Gauterin [10].

Kalman Filtering and Extended Kalman Filtering (EKF) based estimation methods are widely used in vehicle parameter estimation, by Sahlholm, Johansson and Jansson *et al.* [11][12][13]. Vahidi *et al.*[5] use a combination of Kalman Filtering and RLS methods in their approach, as does Raffone[14], while Sebsadji *et al.*[15] combine the Kalman Filtering of the vehicle dynamics with a Luenberger type observer for road gradient.

A number of approaches also use nonlinear observer structures. McIntyre *et al.*[16] and Rajamani *et al.* [17] both make use of Lyapunov based estimators, the latter using roll dynamics for mass estimation, a theme shared with Kim *et al.*[7] who use multiple observer synthesis to combine the results of their longitudinal and lateral dynamics based estimators.

Many of the approaches to the simultaneous mass and road gradient estimation problem already mentioned are model based to some greater or lesser degree. Some model based approaches such as that of Mangan *et al.*[18] make use purely of the Newtonian dynamics of the vehicle system to estimate, in this case, road gradient, whilst others introduce more complex effects. Bae *et al.*[19] uses a model based approach to introduce GPS data to the system, whilst Reineh *et al.* [20] use autoregressive moving average (ARMAX) models and Winstead and Kolmanovsky[21] make use of Model Predictive Control (MPC) and Kalman Filtering to produce their estimates.

As we have already seen, numerous methods in the literature, as well as our own [1] make use of data fusion from additional sensors that are attached to but not necessarily part of the vehicle system. Numerous methods including those of Sahlholm *et al.*[11][12] and Bae and Gerdes[22] have made use of GPS in addition to vehicle sensors. The work of Jansson *et al.*[13] also includes altitude measurements using a barometer, while Caron *et al.*[23] and Sukkariah *et al.*[24][25] both incorporate data from both GPS and IMU/INS systems. It is beneficial to include additional data sources because this reduces the reliance on excitation and accuracy from a single source, thus producing a more reliable and robust estimate. The work of Reineh [20], Kim [7] and Fathy [8] using the results of a relatively decoupled set of vehicle dynamics to reinforce their mass estimates may also be regarded as a form of data fusion. Current practical results for passenger vehicles provide mass estimates within 10% accuracy with a usual settling time of the estimate of more than ~100 seconds [14] [21].

In this paper we will introduce the application of supervisory control methods for selecting appropriate data to drive our estimation methods. Supervisory control is a broad field and different aspects of it are applied to similar problems in the literature, including the use of multiple models for different gearbox ratios by Raffone [14] and selective use of available data by Fathy [8].

The work presented in this paper is a development of a parameter estimation project within the dynamics and control group at the University of Bristol. Vehicular estimation for mass, road gradient and other parameters was begun using standard estimation methods

and adaptive observers from the literature by Chan and Foreman *et al.* [26][27]. A composite estimation algorithm [presented in the mathematical context of this paper] was developed by Na *et al.*[28] and applied to vehicular systems by Mahyuddin *et al.* [29][30]. This algorithm has subsequently been modified to include a novel data fusion method by Wragge-Morley *et al.* [1]

3 Mathematical Context

3.1 Vehicle Modelling

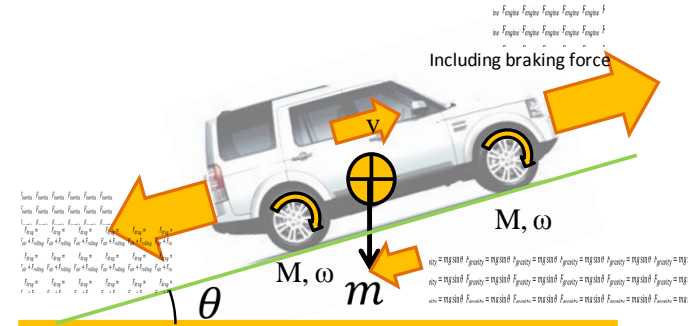

Figure 1. Free body diagram expressing the significant driving and loss forces in longitudinal vehicle dynamics for a vehicle on a fixed road grade.

For the purposes of this paper, we need to consider our model of the vehicle dynamics. We use a simple longitudinal dynamics model incorporating the main resistance forces, but without including too much detail to increase computational speed and simplicity. Within the algorithm, the vehicle dynamics model is incorporated into the observer (10), so it is essential that it be computationally light.

In addition, some inaccuracies in the model may be tolerated by the robust estimation method employed, although there is scope for including certain extra loss force. The main forces on the vehicle are shown on the free body diagram Figure 1. In addition it is important to consider rotational inertias of certain drivetrain components and the torque required to accelerate them. Thus the Newtonian force balance for the main vehicle dynamics is derived as:

$$m\ddot{x} = F_{drive} - mg \sin \theta - C_{\mu}mg \cos - \frac{\rho C_d A_f}{2} \dot{x}^2 \operatorname{sgn} \dot{x} \quad (1)$$

where θ is road gradient, C_{μ} is the coefficient of rolling resistance, ρ is density of the air, and C_d is the aerodynamic drag coefficient of the vehicle body whose frontal area is A_f . Vehicle mass is represented by m and the gravitational constant by g . Meanwhile the states $\mathbf{x} = \begin{bmatrix} x_1 \\ x_2 \end{bmatrix} = \begin{bmatrix} x \\ \dot{x} \end{bmatrix}$ are respectively the displacement and speed of the vehicle.

We wish to consider this model in a standard, state space form shown below in order to allow it to be treated like a set of first order dynamics for the purposes of facilitating the linearisation of the model.

$$\dot{\mathbf{x}} = \mathbf{A}\mathbf{x} + \mathbf{B}_1\mathbf{u}_1 + \mathbf{B}_2f(\mathbf{x}, \mathbf{u}_2) + \zeta \quad (2)$$

The linearisation makes use of the following known and unknown parameters φ and Θ to re-write the dynamics in the form:

$$\begin{aligned} \begin{bmatrix} \dot{x} \\ \dot{x} \end{bmatrix} &= A \begin{bmatrix} x \\ \dot{x} \end{bmatrix} + \begin{bmatrix} 0 \\ 1 \end{bmatrix} \\ &= B_2 \varphi \Theta - \underbrace{\begin{bmatrix} 0 \\ C_\mu \cos \theta \end{bmatrix} g - \begin{bmatrix} 0 \\ \frac{\rho C_d A_f}{2m} \end{bmatrix} \dot{x}^2 \operatorname{sgn} \dot{x}}_{=\zeta} \end{aligned} \quad (3)$$

where the known regressor φ is:

$$\varphi = \begin{bmatrix} -g & F_{drive} \end{bmatrix} \quad (4)$$

the unknown parameters Θ are:

$$\Theta = \begin{bmatrix} s \\ b \end{bmatrix} = \begin{bmatrix} \sin \theta \\ \frac{1}{m} \end{bmatrix} \quad (5)$$

and $B_1 u_1 = 0$. The known parameters are gravity and the powertrain estimate of vehicle driving force, and the unknown parameters which we wish to estimate describe road grade and vehicle mass.

3.2 Filtering

It is undesirable for the purposes of this estimator to derive accelerations directly from the wheel-speed sensor outputs. However, this situation is avoided by applying a filter to the information sources. The second state equation of the vehicle dynamics is:

$$\dot{x}_2 = \bar{B}_2 \varphi \Theta + \zeta_2 \quad (6)$$

where the term $\phi = \bar{B}_2 \varphi$ is created for convenience of notation. First order filters are applied of the form (7) where k is the filter constant. It is significant that this allows us to re-write the derivative of wheel-speed in terms of the measured and filtered wheel-speed (8).

$$\begin{aligned} k\dot{x}_{2f} + x_{2f} &= x_2, & x_{2f}(0) &= 0 \\ k\dot{\phi}_f + \phi_f &= \varphi, & \phi_f(0) &= 0 \\ k\dot{\zeta}_{2f} + \zeta_{2f} &= \zeta_2, & \zeta_{2f}(0) &= 0 \end{aligned} \quad (7)$$

$$\dot{x}_{2f} = \frac{x_2 - x_{2f}}{k} \quad (8)$$

This allows the second state equation to be re-written as:

$$\frac{x_2 - x_{2f}}{k} = \phi_f \Theta + \zeta_{2f} \quad (9)$$

3.3 Novel Observer-Based Parameter Estimation Method

Part of the estimation structure is dependent on an observer using the parameterised vehicle dynamics equation (3);

$$\dot{\hat{x}} = A\hat{x} + B_1 u_1 + B_2 \varphi \Theta + L(y - C\hat{x}) \quad (10)$$

The key elements of the estimation structure developed by Na, Mahyuddin *et al* [28][29][30] are a gradient descent type of algorithm based on the observer error and a regressor-driven structure R made up of terms responsible for finite and exponential time convergence. They are effectively driven by the parameter error, due to a relationship discussed later in this paper.

$$\dot{\hat{\Theta}} = \Gamma \left[\underbrace{\varphi^T F(y - C\hat{x}) - R(t)}_{\text{ObserverError}} \right] \quad (11)$$

$$R(t) = \underbrace{M(t)\omega_1 \Omega \frac{M(t)\hat{\Theta} - N(t)}{\|M(t)\hat{\Theta} - N(t)\|}}_{\text{FiniteTimeConverging}} + \underbrace{M(t)\omega_2 \Omega (M(t)\hat{\Theta} - N(t))}_{\text{ExponentialTimeConverging}} \quad (12)$$

where M is a filtered regressor-based matrix

$$\dot{M}(t) = -k_{ff} M(t) + k_{ff} \phi_f^T(t) \phi_f(t), \quad M(0) = 0 \quad (13)$$

and N is the corresponding filtered regressor-based vector

$$\dot{N}(t) = -k_{ff} N(t) + k_{ff} \phi_f^T(t) \kappa, \quad N(0) = 0 \quad (14)$$

where κ carries the measured states in a filtered form from the LHS of (9) to avoid derivation of accelerations from certain data [1]

$$\kappa = \frac{x_2 - x_{2f}}{k} \quad (15)$$

3.3.1 Regressor Matrix and Vector Relationship

The regressor matrix and vector carry the known parameters and state measurements. According to the second line of the filtered [1][29][30] linear parametrized state equation, these have the relationship shown in (9).

If we pre-multiply equation (9) by ϕ_f and assume $\zeta = 0$, we have a relationship in terms of the information carried by M and N , so it may be seen how the relationship below is derived for $\zeta = 0$:

$$N(t) = M(t)\Theta \quad (16)$$

Thus, the term $N(t) - M(t)\hat{\Theta}$ carries the parameter error information used as a driver of the parameter estimator (11).

3.4 Like-Parameterised Information Fusion

As previously asserted by Wragge-Morley *et al* [1], it is possible to introduce data from additional sensors directly into the regressor structure if their dynamics can be parameterised using the same parameters as the linear parameterisation of the main vehicle dynamics. The example we use is that of an accelerometer set up to detect longitudinal acceleration, as would normally be found as part of the IMU used by vehicle safety systems such as ABS or seatbelt restraints. The accelerations measured by such a sensor.

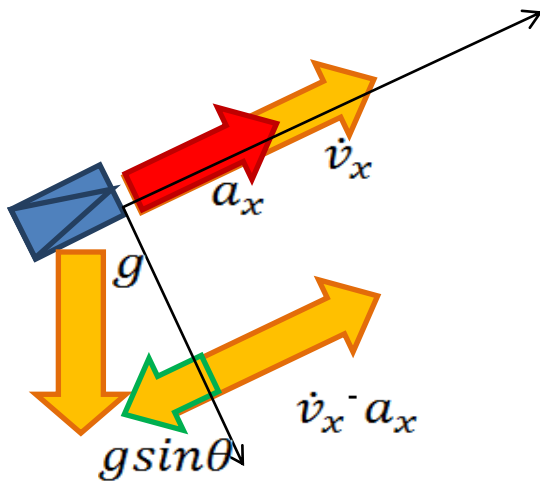

Figure 2. Diagram for the longitudinal accelerometer attached to a vehicular system providing the different accelerations to produce the measured output a_x

$$\dot{v}_x = a_x + g \sin \theta \quad (17)$$

This relationship may be parameterised using the parameters Θ as before, and the known parameters vector may thus be extended to a matrix to include the extra data:

$$\underbrace{\begin{bmatrix} \frac{v_x - v_{fx}}{k} \\ \frac{v_x - v_{fx}}{k} - a_x \end{bmatrix}}_{\kappa} = \underbrace{\begin{bmatrix} -g & F_f \\ g & 0 \end{bmatrix}}_{\phi} \underbrace{\begin{bmatrix} s \\ b \end{bmatrix}}_{\Theta} \quad (18)$$

As demonstrated in [1], this method may be used to reduce the dependence on persistent excitation of the estimator to produce a result. The influence of this improvement is seen in both parameters even though it only directly affects the gradient parameter - feeding an improved gradient parameter into the observer will inherently improve the mass estimate.

4 Use of two different supervisory strategies for smoothing the mass estimate

The main Contribution of this paper concerns itself with increasing the usefulness of the mass estimate by applying two output filtering methods. These methods make use of supervisory data rejection methods to obtain 'cleaner' periods of estimation and apply filtering processes to the output of the estimator. One process relies on identifying periods when the mass estimate has converged on a sensible value, the other on a Kalman filter incorporating supervised data rejection.

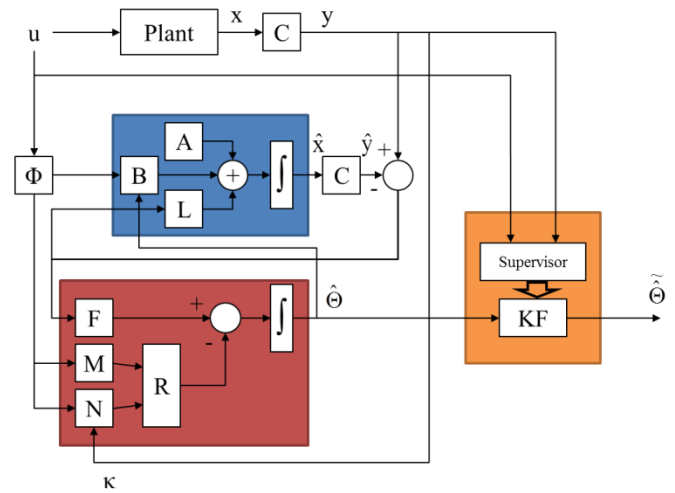

Figure 3. Diagram showing the estimator system structure with the observer and regressor components, the supervisor and output filtering and their dependencies on the real plant inputs and outputs

Presented below in Figure 4 and Figure 5 is a set of mass parameter and gradient estimate results. A duty cycle involving a set of test hills was repeated several times. The gradients up and down repeated in the first section of the drive are +30%, -20%, +15% and -25%. One may notice that the gradient estimate using the like-parameterisation data fusion method is very good, it is compared to a result derived from GPS height data, which it should be noted is less consistent - with a noticeable error in the third repetition of the test. The mass parameter $\hat{b} = \frac{1}{m}$ is displayed overlaid with a lightly filtered version of itself for ease of observation and also with its expected value based on the approximate vehicle mass as tested.

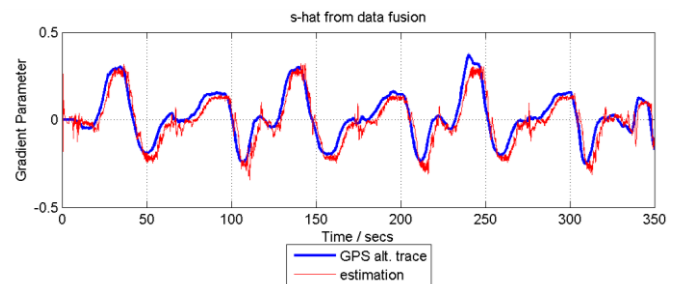

Figure 4. A comparison of gradient estimation from the algorithm presented in this paper and in [1] and the result from a GPS altitude trace for the same driving duty cycle - note the inconsistency of the GPS at around 240 seconds

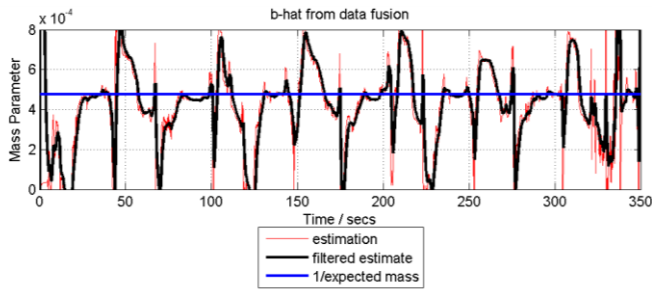

Figure 5. Illustration of the problem of the mass estimation parameter converging on the correct estimate only during certain periods of time. A straight line representing the expected mass may be compared to the raw estimate and its periods of convergence.

We may observe from Figure 4 and Figure 5 that although it is easy enough to recognise a trend in the mass parameter result by eye or off-line regression techniques, and thus derive a mass; the disturbances in the estimate make it rather hard to do this by an on line method.

4.1 Sources of estimation error in the mass result

The errors in the mass result are of different types. These can be categorised in two main ways as 'impulse'-like momentary fluctuations and more prolonged steady state errors. It may be observed that the steady-state errors appear to converge on to two main values for vehicle mass. It may be assumed that the cause of this is some deficiency in the modelling of the powertrain, since the two values correlate to the periods of net-positive and net-negative driving force. The momentary spikes appear to be linked to the various information sources. Singularities able to propagate through the estimation process are linked to zero-crossings in the driving force F_{engine} ; when this known parameter is exactly zero, the matrix ϕ in (18) is singular, which also affects the regressor matrix and vector structures. This produces a requirement for persistent excitation of the estimator which, for the gradient estimate, is overcome to a large extent by the introduction of additional sensor data. Reasons for the low quality of parameter estimates are summarised in Table 1.

Table 1. A brief summary of some of the real world driving events which can lead to problems with reliably estimating vehicle mass.

Braking	The Braking forces are an estimation arrived at in a crude manner and broadcast on the CAN bus and may not therefore be treated as well known
Small driving force	When the driving force approaches zero, there is a lack of information driving the estimation algorithm, with the numerical result that the matrix (or vector) ϕ approaches singularity, leading to erratic results
Gradient Zero Crossing	This is not inherently a problem, except that sudden changes from steep positive to steep negative gradients tend to trigger a driver behaviour that leads to a zero crossing in the force, thus precipitating the effect discussed above.
Steering/Cornering	Steering the vehicle adds additional friction losses which are difficult to model, and also a differential effect in the wheelspeeds

A supervisory control element has been implemented to reject the mass estimate when the conditions in Table 1. Thus, reducing the likelihood of strong disturbing influences on the eventual result. It should be noted that because it is necessary for the gradient estimate

to be a continuous process, it is impractical for the algorithm to simply be 'paused' when the conditions are not met, as both gradient and mass are calculated simultaneously. Thus this logical process constitutes the first stage of an output filter for the mass parameter. The periods of data 'rejection' are shown in Figure 7.

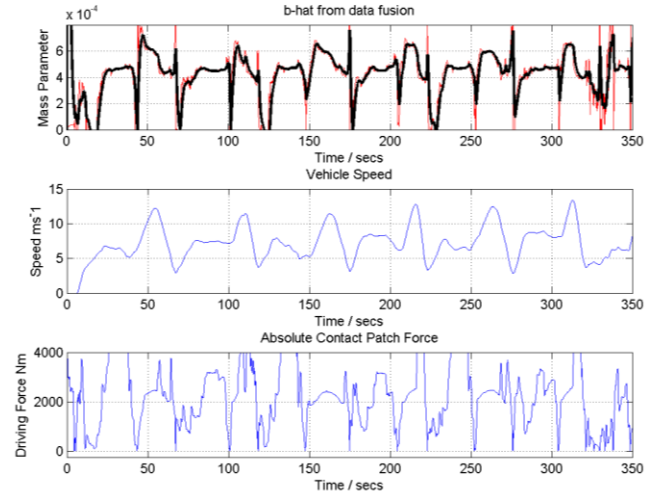

Figure 6. Illustrations of the effect of certain aspects of the driving duty cycle on the quality of the mass parameter $\hat{b} = \frac{1}{m}$ (Top). The vehicle speed being low (stationary) at the beginning of the run has a large impact on initial conditions because this introduces a set of conditions where the measured accelerations and forces do not match and errors between them are greatly amplified (Middle), it should also be noted that the local minima in the speed trace represent the vehicle negotiating a tight turn, which introduces additional losses and these points coincide with the end of periods of low confidence in the driving force estimate due to deceleration. The absolute value of driving force (bottom) shows a clear correlation with the shape of the mass parameter estimate, especially between 'small' force measurements and singularities in the output solution.

In this paper we examine two methods for rejecting the disturbances to the mass estimate, the first utilising an analysis of the mass parameter to determine periods of convergence on a steady value, and the second using a supervised Kalman Filter to smooth the result. For the purposes of both these pieces of work, it is assumed that the dynamics of mass change are slow enough for it to be assumed constant whilst the vehicle is moving. A 2000kg vehicle using a 60kg tank of fuel to travel 600km at an average of 80km/h represents a 3% change in mass of 0.4% over each hour of driving due to fuel consumption. Step changes in mass due to loading and unloading of the vehicle are more significant.

4.2 Supervised Output Filtering using Convergence Location Method

As discussed there are a number of influences on the mass result which may be isolated by observation of the input data to the estimation algorithm. These influences are summarised in Table 1.

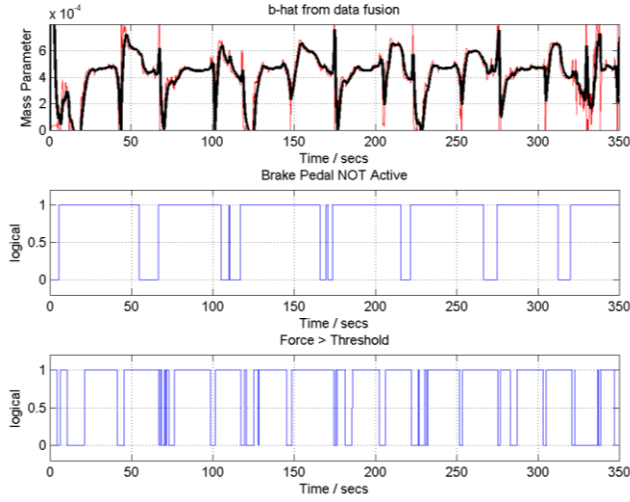

Figure 7. Illustration of two of the logical metrics used to select data for use in the estimate-convergence output filtering method. The raw mass parameter $\hat{b} = \frac{1}{m}$ estimate is shown again (Top) to allow comparison between data rejection and periods of good estimate.

The mass estimate that remains after data rejection is examined for convergence on a constant value, with the assumption that within sensible bounds, a period of convergence will imply a period of good estimate when we believe the input data to be good. The method employed for this test is a moving average of the change in estimated mass over a time interval of $n + 1$ samples:

$$\tilde{b} = \frac{1}{n+1} \sum_{i=t-n}^t (\hat{b}_i - \hat{b}_i) \quad (19)$$

Hence, the convergence of the estimate at a point in time is defined as when the average of the variation in the previous $n + 1$ samples of the estimate are within some pre-defined bounds. The sampling rate and bound that implies convergence may be tuned for the particular scenario to get the best results. When the conditions for convergence are met, the mass estimate is taken as the average value of mass across the period of convergence and the output result is updated.

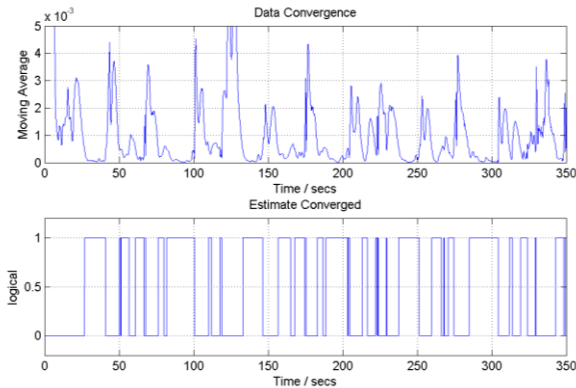

Figure 8. The moving average of the temporal gradient of the error mass estimate $\hat{b} = \frac{1}{m}$ with itself over a predefined time before the present (Top) is compared to a threshold to give an indication of periods of convergence of the estimate (Bottom).

4.3 Supervised Output Filtering

Another technique that has been employed to good effect for extracting a good mass estimate is to use Kalman filtering. This has several advantages over the method discussed in the previous section; not least that the requirement for rejecting large amounts of available data is substantially reduced. By the nature of its formulation, the Kalman Filter is informed about the dynamics of the state it is to estimate and *a priori* quantitative knowledge of the noise properties of the state and measurements. Since there is an element of conformity in potential duty cycles, we may assume that fixed values for covariance of readings for a particular vehicle system and estimator tuning may be used.

4.4 Kalman Filter Formulation

A continuous time Kalman Filter formulation is used for this application [2][3] in conjunction with a supervisor to obtain a robust mass estimate based on selected periods of data. The system equations for the estimated state conform to following standard form:

$$\dot{x}_m = A_m x_m + w \quad (20)$$

$$y_m = C_m x_m + v \quad (21)$$

where w and v are continuous time white noise processes:

$$w \sim (0, Q_c) \quad (22)$$

$$v \sim (0, R_c) \quad (23)$$

The continuous time Kalman Filtering process presented by Simon [2] is initialised by:

$$\hat{x}_m(0) = E[x_m(0)] \quad (24)$$

$$P(0) = E[(x_m(0) - \hat{x}_m(0))(x_m(0) - \hat{x}_m(0))^T] \quad (25)$$

and propagated according to the following rules for the covariance:

$$\dot{P} = -PC_m^T R_c^{-1} C_m P + A_m P + P A_m^T + Q_c \quad (26)$$

and estimated state:

$$\dot{\hat{x}}_m = A_m \hat{x}_m + K(y_m - C_m \hat{x}_m) \quad (27)$$

where the Kalman gain K is:

$$K = PC_m^T R_c^{-1} \quad (28)$$

For the specific application with which we are concerned, the 'state' is the raw mass estimate from the nonlinear adaptive observer algorithm with data fusion in the regressor. As previously stated, it is assumed that the parameter is a constant while the vehicle is in motion, therefore the Kalman Filter in this specific case is:

$$\dot{\hat{x}}_m = K(y_m - C_m \hat{x}_m) \quad (29)$$

It is assumed that the noise covariance of the state itself w is nil, since the state itself (in this case the mass parameter) should not be subject to change during a period of the filter being active; this is due to the earlier assumptions surrounding the speed of the mass change dynamics of a passenger vehicle system. The measurement noise v is treated as encompassing all disturbances and a value for the measurement noise covariance R_c is chosen to reflect this. The measurement does not add any gain to the estimated value, so that $y_m = x_m$ and the measurement gain matrix $C = [1]$ is an identity.

This allows the Kalman gain and covariance propagation equations to be reduced to:

$$K = PR^{-1} \quad (30)$$

$$\dot{P} = -PP^T R_c^{-1} + Q_c \quad (31)$$

4.4.1 Application of a supervisor to the Kalman Filter

In order to further improve the performance of the final mass estimate obtained by filtering the output of the observer-regressor structure, we can discount certain periods of estimation as discussed in the previous section. The Kalman Filtered result is much more robust to the considered disturbances than the convergence identification method, so it is not necessary to reject so much data. In this case the most relevant metric for indicating an appropriate level of excitation is driving force.

If we once again examine the extended regressor structure, we will note that the dynamic behaviour of the mass estimate is still dependent on the driving force only - the extra sensor data only directly affects the gradient estimate since it is a kinematic measure that is not affected by vehicle mass; as mentioned earlier in this paper, this has the effect of indirectly improving the mass estimate by including a much improved gradient estimate in the observer. The difficulties encountered as a result are mitigated for the gradient estimate to a great extent by the data fusion, but this is not the case for the mass estimate. Therefore we reject the mass estimate feeding the Kalman Filter as the driving force approaches zero.

The filter is set up in such a manner as to be 'frozen' during the data-rejection periods. The previous values for adaptation gains and outputs are retained.

5 Results of Improved Parameter Estimation Methods

The convergence-detection method of determining an estimate is effective for extracting a single period of converged estimate, however each updated estimate is independent of the preceding one so it carries no history. Therefore it suffers from being affected by medium term disturbances, such as the effect of positive or negative overall driving force on the driveline dynamics which has previously been alluded to. Some extra logical calculations would be required to make this method produce a practicable real time result by taking account of the history of the estimate and additional environmental factors.

This estimation process gave the following result from a set of data collected from the CAN-bus a petrol engine car at Lommel. Proving Ground in northern Belgium. It should be noted that quite a high proportion (63%) of data was rejected according to the logic described in this paper.

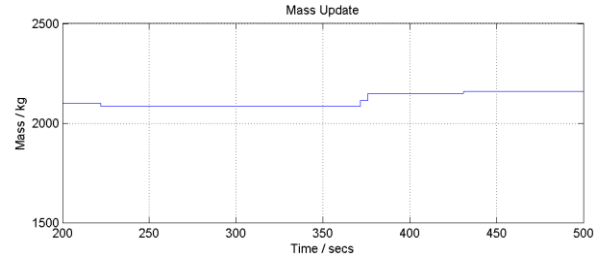

Figure 9. A section of mass estimate from the parameter-convergence method, illustrating the discrete nature of the mass output

The Kalman filtered methods behave in a more continuous manner, even with the supervisor applied, the value of the output is simply 'held' rather than being updated in a discontinuous manner. In the data below, it should be noted that the drift caused in the *unsupervised* version of the filtering algorithm by singularities in the solution of $\hat{b} = \frac{1}{m}$ lead to sporadic large mass estimates when the driving force is small; there is no phenomenon that naturally counteracts this effect, thereby causing a positive drift in the estimate. When these periods of data are removed, the estimate converged on a realistic estimate.

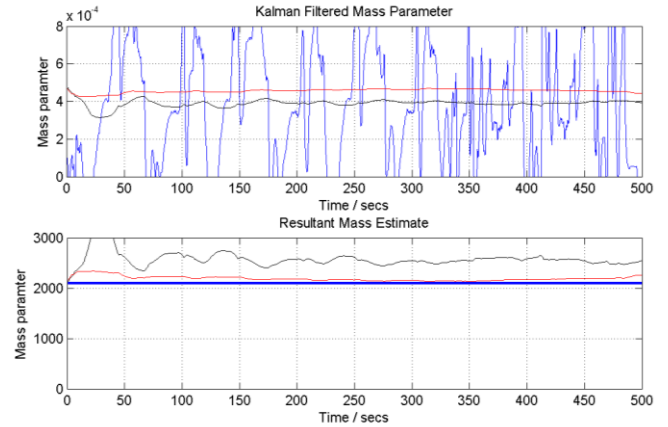

Figure 10. Results of applying Kalman Filtering (black) and supervised Kalman Filtering (red) to the output of the mass estimation process. The unsupervised Kalman filter suffers some colouration from the zero-crossings caused in the output by weak driving force information. The rejection of data from periods of very low driving force magnitude significantly improves on this phenomenon.

6 Summary/Conclusions

We have shown that by applying a supervised output filter to a novel nonlinear adaptive observer based data fusion algorithm with data fusion as part of the extended regressor, we provide a relatively undisturbed, noise free vehicle mass estimate simultaneously to the good road grade estimate produced by the data fusion algorithm structure. These methods have been demonstrated using real vehicle systems and it has been shown that in their present form, the limiting factor on estimate quality seems to be the quality of the driving torque signals available. The current state of the art seems from a review of the literature to be an error of around 10% on the mass estimate and our results are within that bound, importantly the supervised Kalman-Filter based output method provides rapid convergence on a sensible result, settling within 50 or 60 seconds even in the presence of large disturbance-inducing effects at the

beginning of data runs. Hence, our robust results are indeed faster than previous results

References

- [1] R. Wragge-Morley, G. Herrmann, P. Barber and S. Burgess, "Information fusion for vehicular systems parameter estimation using an extended regressor in a finite time estimation algorithm," in *IEEE/UKACC Conference on Control 2014*, Loughborough, U.K., 2014.
- [2] D. Simon, *Optimal State Estimation*, Wiley Interscience, 2006.
- [3] J.-J. Slotine and W. Li, *Applied Nonlinear Control*, Prentice-Hall, 1991.
- [4] I. Landau, R. Lozano and M. M'Saad, *Adaptive Control*, London: Springer Verlag, 1998.
- [5] A. Vahidi, M. Druzhinina, A. Stefanopoulou and H. Peng, "Simultaneous Mass and Time-Varying Grade Estimation for Heavy-Duty Vehicles," in *Proceedings of the American Control Conference*, Denver, Colorado, 2003.
- [6] K.-J. Han, I.-K. Kim, H. Y. Jo and K.-S. Huh, "Development and experimental evaluation of an online estimation system for vehicle mass," *Journal of Automobile Engineering*, vol. 223 part D., pp. 167-176, 2009.
- [7] D. Kim, S. B. Choi and J. Oh, "Integrated Vehicle Mass Estimation Using Longitudinal and Roll Dynamics," in *ICROS 12th International Conference on Control, Automation and Systems*, Jeju Island, Korea, 2012.
- [8] H. K. Fathy, D. Kang and J. L. Stein, "Online Vehicle Mass Estimation Using Recursive Least Squares and Supervisory Data Extraction," in *2008 American Control Conference*, Seattle, Washington, 2008.
- [9] M. B. Khaknejad, R. Kazemi, S. Azadi and A. Keshavarz, "Identification of vehicle Parameters using Modified Least Square Method in ADAMS/Car," in *Proceedings of 2011 International Conference on Modelling, Identification and Control*, Shanghai, China, 2011.
- [10] S. Rode and F. Gauterin, "Online Estimation of Vehicle Driving Resistance Parameters with Recursive Least Squares and Recursive Total Least Squares," in *IEEE Intelligent Vehicles Symposium*, Gold Coast, Australia, 2013.
- [11] P. Sahlholm and K. H. Johansson, "Road grade estimation for look-ahead vehicle control using multiple measurement runs," *Control Engineering Practice*, vol. 18, pp. 1328-1341, 2010.
- [12] P. Sahlholm and K. H. Johansson, "Segmented road grade estimation for fuel efficient heavy duty vehicles," in *IEEE Conference on Decision and Control*, Atlanta, Georgia, 2010.
- [13] H. Jansson, E. Kozica, P. Sahlholm and K. H. Johansson, "Improved road grade estimation using sensor fusion," in *Reglermte Conference*, Stockholm, Sweden, 2006.
- [14] E. Raffone, "Road Slope and Vehicle Mass Estimation for Light Commercial Vehicle using Linear Kalman Filter and RLS with forgetting factor integrated approach," in *16th International Conference on Information Fusion*, Istanbul, Turkey, 2013.
- [15] Y. Sebsadji, S. Glaser, S. Mammam and J. Dakhllallah, "Road Slope and Vehicle Dynamics Estimation," in *Proceedings of the American Control Conference*, Seattle, Washington, 2008.
- [16] M. L. McIntyre, T. J. Ghotikar, A. Vahidi, X. Song and D. M. Dawson, "A Two-Stage Lyapunov-Based Estimator for Estimation of Vehicle Mass and Road Grade," *IEEE Transactions of Vehicular Technology*, Vols. 58, no. 7, pp. 3177-3185, 2009.
- [17] R. Rajamani, D. Piyabongkarn, V. Tsourapas and J. Y. Lew, "Parameter and State Estimation in Vehicle Roll Dynamics," *IEEE Transactions on Intelligent Transportation Systems*, vol. 12 no. 4, pp. 1558-1567, 2011.
- [18] S. Mangan and J. Wang, "Development of a Novel Sensorless Longitudinal Road Gradient Estimation Method Based on Vehicle CAN Bus Data," *IEEE/AMSE Transactions on Mechatronics*, Vols. 12, no 3, pp. 375-386, 2007.
- [19] H. S. Bae, J. Ryu and C. Gerdes, "Road Grade and Vehicle Parameter Estimation for Longitudinal Control Using GPS," in *Proceedings of the IEEE Conference on Intelligent Transportation Systems*, San Francisco, California, 2001.
- [20] M. S. Reineh, M. Enqvist and F. Gustafsson, "Detection of Roof Load for Automotive Safety Systems," in *52nd IEEE Conference on Decision and Control*, Florence, Italy, 2013.
- [21] V. Winstead and I. V. Kolmanovsky, "Estimation of Road Grade and Vehicle Mass via Model Predictive Control," in *Proceedings of the 2005 IEEE Conference on Control Applications*, Toronto, Canada, 2005.
- [22] H. S. Bae and J. C. Gerdes, "Parameter Estimation and Command Modification for Longitudinal Control of Heavy Vehicles," Institute of Transportation Studies, University of California, Berkeley, 2003.
- [23] F. Caron, E. Duflos, D. Pomorski and P. Vanheeghe, "GPS/IMU Data Fusion using Multisensor Kalman Filtering: Introduction of Contextual Aspects," *Journal of Information Fusion*, 2004.
- [24] S. Sukkariah, E. M. Nebot and H. F. Durrant-Whyte, "A High Integrity IMU/GPS Navigation Loop for Autonomous Land Vehicle Applications," *IEEE Transactions on Robotics and Automation*, vol. 15 no. 3, pp. 572-578, 1999.
- [25] S. Sukkariah, E. M. Nebot and H. F. Durrant-Whyte, "Achieving Integrity in an INS/GPS Navigation Loop for Autonomous

Vehicle Applications,” in *Proceedings of the 1998 IEEE International Conference on Robotics & Automation*, Leuven, Belgium, 1998.

[26] J. P. Foreman, M. Yazdouni, S. Russo, G. Chan, G. Herrmann and P. Barber, “Hardware in the loop validation of a gradient and weight estimation algorithm and longitudinal speed control of a laboratory model car,” in *International Conference on Systems Engineering*, Coventry, U.K., 2009.

[27] G. Chan, J. Foreman, S. Russo and M. Yazdouni, “Adaptive observer-based parameter estimation with application to road gradient and vehicle mass,” University of Bristol, Bristol, 2009.

[28] J. Na, G. Herrmann, X. Ren, M. N. Mahyuddin and P. Barber, “Robust Adaptive Finite-Time Parameter Estimation and Control of Nonlinear Systems,” in *IEEE Multi-Conference on Systems and Control*, Denver, Colorado, 2011.

[29] M. N. Mahyuddin, J. Na, G. Herrmann, X. Ren and P. Barber, “Adaptive Observer-based Parameter Estimation with Application to Road Gradient and Vehicle Mass Estimation,” *IEEE Transactions on Mechatronics*, vol. 61 no 6, 2014.

[30] M. N. Mahyuddin, J. Na, G. Herrmann, X. Ren and P. Barber, “An Adaptive Observer-based Parameter Estimation Algorithm with Application to Road Gradient and Vehicle Mass Estimation,” in *IEEE UKACC International Conference on Control 2012*, Cardiff, U.K., 2012.

Acknowledgments

The authors would like to thank Jaguar and Land Rover Research for the support of this project and also Flandersdrive, Ford Lommel Proving Ground and in particular all the personnel who drove the cars for various data gathering activities.