

Gas-phase Lifetimes of Nucleobase Analogues by Picosecond Pump-ionization and Streak Techniques

Susan Blaser[§], Hans-Martin Frey, Cornelia G. Heid^a, and Samuel Leutwyler^{*}

[§]SCS-Metrohm Foundation Award for best oral presentation

Abstract: The picosecond (ps) timescale is relevant for the investigation of many molecular dynamical processes such as fluorescence, nonradiative relaxation, intramolecular vibrational relaxation, molecular rotation and intermolecular energy transfer, to name a few. While investigations of ultrafast (femtosecond) processes of biological molecules, *e.g.* nucleobases and their analogues in the gas phase are available, there are few investigations on the ps time scale. We have constructed a ps pump-ionization setup and a ps streak camera fluorescence apparatus for the determination of lifetimes of supersonic jet-cooled and isolated molecules and clusters. The ps pump-ionization setup was used to determine the lifetimes of the nucleobase analogue 2-aminopurine (2AP) and of two 2AP·(H₂O)_n water cluster isomers with n=1 and 2. Their lifetimes lie between 150 ps and 3 ns and are strongly cluster-size dependent. The ps streak camera setup was used to determine accurate fluorescence lifetimes of the uracil analogue 2-pyridone (2PY), its self-dimer (2PY)₂, two isomers of its trimer (2PY)₃ and its tetramer (2PY)₄, which lie in the 7–12 ns range.

Keywords: 2-Aminopurine · Lifetimes · Picosecond pump-ionization · Picosecond streak camera · 2-Pyridone

1. Introduction

Many molecular dynamic processes take place on the picosecond (ps) time scale. These include relaxation processes such as fluorescence, internal vibrational relaxation (IVR), intersystem crossing (ISC), molecular rotation, collisional energy transfer and dephasing and intermolecular electronic energy transfer. The development of stable ps sources in the early 70s allowed fluorescence and Raman decay measurements^[1,2] and first pump-probe experiments by Lauberau.^[3] Hochstrasser *et al.* extended the range from the visible to the infrared (IR) and performed ps experiments on photochemi-

cal predissociation and fluorescence in the condensed phase.^[4–6] Zewail and co-workers transferred these methods into the gas-phase and to molecular beams, including time-resolved structural changes by ultrafast electron diffraction techniques.^[7–9]

Recent ps investigations on gas-phase molecules have focused on ground- and excited state IVR, which occurs on a timescale of 0.5–100 ps. Mikami and co-workers have studied the ground state IVR dynamics of organic UV chromophores and clusters using ps IR-UV pump-probe experiments, and for instance have determined the IVR lifetime of the OH $\nu=1$ vibrational stretch of phenol as 14 ps.^[10,11] Reid and co-workers have investigated IVR mechanisms in electronically excited states by combining ps time-resolved photoelectron spectroscopy with the pump-ionization method.^[12] This yields ps time-resolved information on the internal state distribution of the newly-formed ion and thereby on the IVR process of the excited-state neutral molecule.^[12] These selected examples show that the ps time range is of great importance in the understanding of intramolecular dynamics.

Here we describe a pulsed supersonic beam apparatus that combines two different ps techniques with a laser spectroscopic resolution of about 10 cm⁻¹ in the UV between 215 and 350 nm (Fig. 1): A pump/ionization experimental setup (A) is able to resolve excited-state lifetimes from ~20

ps up to ~3 ns. This is complemented by a ps streak-camera setup (B) for measuring decays over the 50 ps to 100 ns time range. As an application of the pump-probe setup, we present lifetimes of 9H-2-aminopurine (2AP), which is a weakly fluorescent isomer of adenine (6-aminopurine) and of its water clusters 2AP·(H₂O)_n with n=1 and 2. The ps streak camera setup was used to investigate the fluorescent *cis*-amide 2-pyridone (2PY) and its dimer, trimers and tetramer. All molecules/clusters were cooled to ~3 K in a pulsed supersonic molecular beam.

2. Experimental Setups

2.1 Picosecond Pump-Ionization Setup

Fig. 1 shows a scheme of the ps pump-ionization apparatus (A). The molecular sample is placed in a 20 Hz magnetically pulsed supersonic jet nozzle and heated to a vapor pressure of 0.2–2 mbar, corresponding to temperatures of 80 °C to 230 °C. The vapor is entrained in a noble gas carrier at 1–2 bar (Ne or Ar) and expanded into the molecular beam source chamber (5·10⁻⁵ mbar during operation). The core of the resulting pulsed supersonic jet is extracted through a 2 mm diameter skimmer and enters the ion source of a 0.90 m long linear Wiley-McLaren type time-of-flight mass spectrometer (TOF-MS) that is or-

^{*}Correspondence: Prof. Dr. S. Leutwyler
Universität Bern
Departement für Chemie und Biochemie
Freiestrasse 3
CH-3012 Bern
Tel.: +41 31 631 44 79
E-mail: leutwyler@iac.unibe.ch
^aCurrent address: Dept. of Chemistry
University of Wisconsin-Madison
Madison, Wisconsin 53706, USA

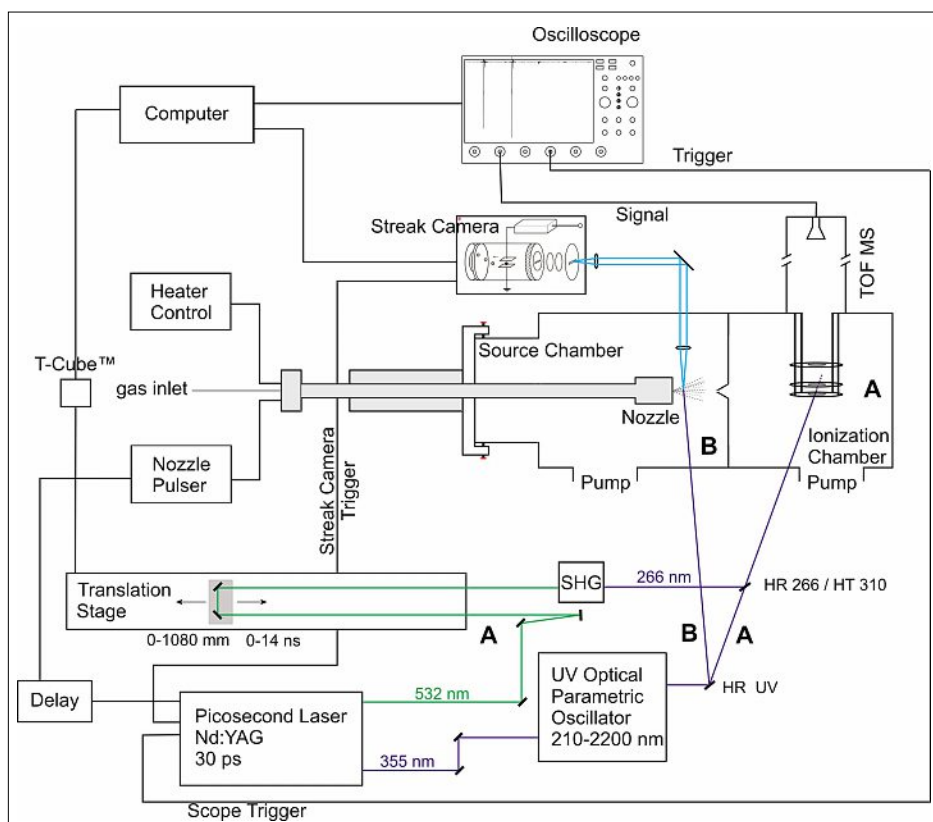

Fig. 1. Experimental scheme of the ps pump-ionization setup (A) and ps streak camera setup (B).

thogonal to the molecular and laser beams. The synchronization of the pulsed nozzle relative to the ps laser is controlled by a Berkeley Nucleonics Corporation (BNC) 575 digital delay/pulse generator.

A 20 Hz Nd:YAG ps laser system (EKSPLA PL2441, fiber oscillator in combination with a regenerative amplifier/double pass amplifier) produces laser pulses of ~ 25 ps/80 mJ at 1064 nm, 40 mJ at 532 nm and 24 mJ at 355 nm. The 355 nm output pumps an EKSPLA PG401 UV optical parametric oscillator/amplifier (OPO/OPA) system that is tunable from 210–350 nm and delivers ~ 60 μ J pulses of ~ 20 ps length and ~ 10 cm^{-1} bandwidth. The UV output is tuned to a molecule-specific frequency, collimated to a 3 mm diam. beam by two $f=1000$ mm lenses and crossed with the molecular beam inside the TOF-MS ion source. The molecules are $S_0 \rightarrow S_1$ excited by the UV OPO/OPA and then ionized by a 266 nm (~ 20 ps) pulse that is superimposed with the UV from the tunable OPO. The spindle of the translation stage is actuated with a DC micromotor driven by a Thorlabs T-Cube™ controller that is interfaced to a PC under LabView control. The exact travel distance is determined by a Faulhaber HEDS5500A optical encoder

that is attached to the spindle, with a resolution of 1.4286 $\mu\text{m}/\text{step}$, corresponding to 9.530 fs/step. The translation stage is scanned at a constant rate while simultaneously recording the mass-separated ion signals from the pump-ionization process. The data acquisition is speeded up by operating the digital oscilloscope (LeCroy Waverunner 104Xi-A) in sequence mode, and doubled by recording data during both travel directions of the stage. As a typical example, the oscilloscope records 1192 mass spectra at 20 Hz while the translation stage travels 150 mm. This corresponds to 1.7 measurements per ps or a resolution of 0.6 ps. The ion signal ps transients are fitted with an IDL program using a Levenberg-Marquardt-routine which is a least-square algorithm with variable step size.

2.2 Picosecond Streak Camera Setup

Fig. 1 also shows a second setup (B) that is combined with the same molecular beam apparatus, which measures the fluorescence lifetimes of excited species using a ps streak camera: The ~ 20 ps UV output of the OPO/OPA is directed into the source chamber and crosses the supersonic jet orthogonally ~ 3.5 mm downstream of the nozzle. The emitted fluorescence is collected with an $f=150$ mm quartz UV lens, collimated onto a UV reflective plane mirror and focused on the horizontal entrance slit of a Hamamatsu C5680-21 ps streak camera. The

lens. The streak camera is triggered with a pre-delay (up to -80 ns) from the PL2441 Nd:YAG via a BNC 745 ps delay generator, allowing accurate (<25 ps) and convenient (ps delay steps) pretriggering. The image at the streak camera output is recorded with a Hamamatsu ORCA-Flash 4.0 CCD. The shortest decay time that can be usefully measured is ~ 30 ps. The Hamamatsu program saves the streak camera measurements as ITEX image files. These are first read in and converted into a data array. We employ a self-written time decay analysis in IDL using a multiexponential model and perform the fits with a Levenberg-Marquardt routine.

3. 2-Aminopurine and its Water Clusters

The $^1\pi\pi^*$ state lifetime of bare 2-aminopurine (2AP) has been previously determined from the Lorentzian broadening of the electronic origin (0_0^0 band) rotational contour as $\tau = 77 \pm 20$ ps.^[13] Nanosecond pump-probe measurements of the lifetime of 2AP and 2AP $\cdot(\text{H}_2\text{O})_n$ $n=1$ and 2 clusters with the H_2O located at the Sugar-edge site have indicated lifetimes <3 ns.^[14,15] Fig. 2 shows the pump-ionization decay traces of 2AP monomer and of the Sugar-edge water cluster isomers 1A and 2A;^[14,15] the respective structures are included in Fig. 2. The transients were measured at the re-

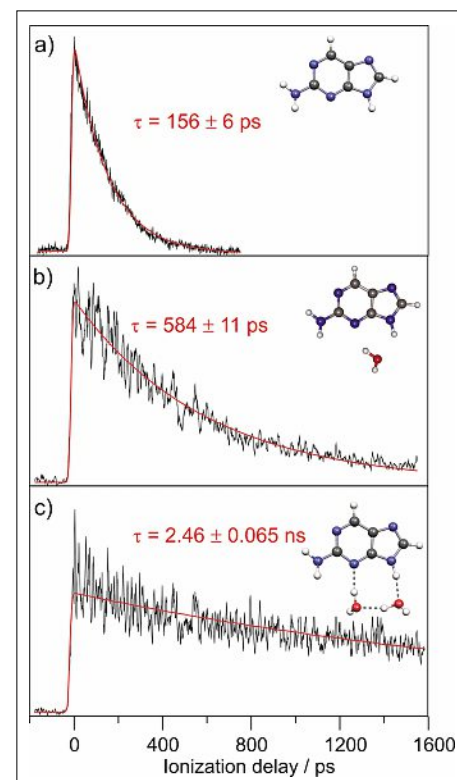

Fig. 2. Ionization delay transients of (a) 2-aminopurine, excitation at 32362 cm^{-1} , (b) 2-aminopurine- H_2O isomer 1A, excitation at 32292 cm^{-1} , (c) 2-aminopurine- $(\text{H}_2\text{O})_2$ isomer 2A, excitation at 32163 cm^{-1} .

spective $S_0 \rightarrow S_1$ origins, which are 32362 cm^{-1} for 2AP, 32292 cm^{-1} for isomer 1A of 2AP·H₂O and 32163 cm^{-1} for isomer 2A of 2AP·(H₂O)₂.^[14,15] For 2AP we obtain a pump-ionization lifetime of $\tau = 156 \pm 6$ ps. This is about twice the value derived from the rotational contour simulation.^[13] This indicates that while lifetime broadening has an effect on the rotational contour, there are additional broadening mechanisms that have not yet been taken into account. One of these is the inversion tunneling of the 2-amino group, which gives rise to two sub-bands and which may increase to the 0_0^0 band width.

The lifetimes of the 2AP·(H₂O)_n $n=1$ and 2 clusters are $\tau = 584 \pm 11$ ps for isomer 1A and $\tau = 2.460 \pm 0.065$ ns for isomer 2A. Hydrogen-bonding of one or two H₂O molecules at the Sugar-edge site (1A, 2A) increases the 2AP lifetime by factors of 4 and 16 respectively. This reflects the influence of H-bonding on the lowest $^1n\pi^*$ excited state, which is near-degenerate with and closely coupled to the optically bright $^1\pi\pi^*$ state.^[16] In bare 2AP this $^1n\pi^*/^1\pi\pi^*$ coupling gives rise to rapid ($k = 6 \cdot 10^9 \text{ s}^{-1}$) nonradiative relaxation, which is slowed down by increasing solvation.^[16]

These measurements reveal some advantages of the ps pump-ionization setup: i) The molecular and cluster lifetimes can be measured in a cluster mass-specific and often isomer-specific manner. ii) The time resolution – given by the temporal convolution of the pump and ionization pulses – is ~ 30 ps, which is typically 3–6 times better than in the streak camera experiment, see below. iii) The photoions are collected and detected with near-unity efficiency. iv) Since several cluster masses are measured simultaneously, there is a potential multiplex advantage, and effects of cluster fragmentation can be diagnosed. Among the disadvantages, we note: i) Only one point on the pump/probe transient can be measured per shot. ii) Longer lifetimes than ~ 3 ns are increasingly difficult to measure because of the finite pointing stability of the delay stage and slow pointing drifts of the two lasers. iii) The density of molecules/clusters is ~ 500 times lower in the TOFMS source than in front of the pulsed nozzle. iv) The ionization pulse energy cannot be increased without limits because of spurious one-color two-photon ionization processes.

4. 2-Pyridone Clusters

We tested the ps streak camera setup using 2-pyridone (2PY) and its self-dimer (2PY)₂ because their $^1\pi\pi^*$ state fluorescence lifetimes have been previously determined *via* the Lorentzian widths of individual rovibronic lines as $\tau = 11.4 \pm 0.1$ ns for 2PY and $\tau = 9.0 \pm 0.1$ ns for (2PY)₂.^[17,18]

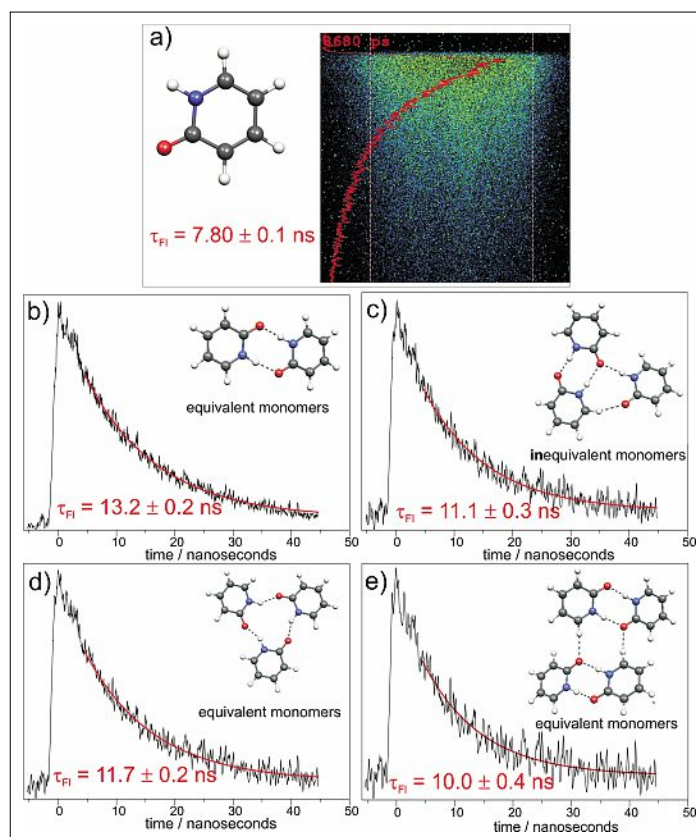

Fig. 3. Ps streak camera image of a) 2-pyridone fluorescence. Fluorescence time profiles and exponential decay fits of b) the (2PY)₂ dimer, c) the (2PY)₃ isomer A, d) the (2PY)₃ isomer B and e) the (2PY)₄ tetramer.

Furthermore, we investigated two isomers of the 2-pyridone trimer (2PY)₃, denoted A and B, and the (2PY)₄ homo-tetramer, which have been identified and assigned by resonant two-photon ionization spectroscopy.^[19] All species were excited at their respective 0_0^0 transitions, which are at 29886 cm^{-1} (2PY), 30807 cm^{-1} (2PY)₂, 30931 cm^{-1} for the low-symmetry (2PY)₃ isomer A, 30988 cm^{-1} for the high-symmetry (2PY)₃ isomer B and 30572 cm^{-1} for the (2PY)₄ homo-tetramer.^[19] Fig. 3 shows the respective fluorescence lifetime measurements, lifetime fits and *ab initio* optimized ground-state structures.

The ps streak camera lifetime of 2PY in Fig. 3 is fitted as $\tau_n = 7.80 \pm 0.05$ ns (1σ). This is somewhat shorter than the 11 ± 1 ns determined by Held *et al.* from the Lorentzian broadening of individual rotational lines.^[17] The lifetime of (2PY)₂ is $\tau_n = 13.2 \pm 0.2$ ns. This 70% increase in lifetime relative to 2PY is in agreement with previous observations that bridging the *cis*-amide H-N-C=O group of 2PY with two or more H-bonds prevents out-of-plane twisting of the NH and C=O bonds in the $^1\tau\pi^*$ state, thereby blocking the access to the lowest conical intersection of 2PY.^[20] Held *et al.* determined the (2PY)₂ lifetime *via* Lorentzian line-broadening as 9 ± 1 ns.^[18] Given that this lifetime is 4 ns shorter while the 2PY lifetime is 2.2 ns longer than the ps streak camera measurements, and given the much smaller fit errors of the latter, we suggest that the Lorentzian broadening lifetime determinations have

a ± 2 ns (1σ) uncertainty, which is twice that indicated in refs. [17] and [18]. In this case, the differences relative to the ps streak camera measurement lie within $\pm 2\sigma$ for 2PY and (2PY)₂.

The lifetimes of the two isomers of (2PY)₃ are intermediate between those of 2PY and (2PY)₂. The C₃ symmetry isomer B has a lifetime $\tau_n = 11.7 \pm 0.2$ ns. The low-symmetry C₁ isomer A has a slightly shorter lifetime $\tau_n = 11.1 \pm 0.3$ ns. The lifetime of (2PY)₄ was determined as $\tau_n = 10.0 \pm 0.4$ ns. A reason for this pattern of lifetimes with increasing cluster size is that the H-bonds are strongest in the dimer, which exhibits a planar H-bonded 8-center ring. In the trimers and tetramer the H-bond arrangements are increasingly strained and twisted,^[19] which leads to a weaker clamping and allowing easier out-of-plane twisting of the H-N-C=O group and more rapid radiationless relaxation.^[20]

The ps streak camera setup has the advantage that: i) the local density in the beam is higher in front of the pulsed nozzle, ii) the entire lifetime range (0.2–50 ns) is measured for every laser shot, iii) the measurement accuracy for lifetimes >500 ps is good and becomes increasingly better with increasing lifetime. Disadvantages are: i) Fluorescence measurements are not intrinsically mass- or species-specific and may contain contributions from other fluorescent species. ii) The accuracy of lifetimes <200 ps decreases rapidly with decreasing lifetime. iii) The maximum efficiency for collecting photons is $\sim 3\%$ and this cannot

be increased without deteriorating the time resolution.

5. Conclusions

With the ps pump-ionization setup we have measured the excited-state decays of 2-aminopurine (2AP) and its water clusters 1A and 2A which could not be previously resolved with ns experiments.^[13–15] All fits resulted in monoexponential decays. The ~155 ps lifetime for the monomer is twice the value determined *via* Lorentzian line broadening of the 2AP rotational contours.^[13] This makes it clear that additional broadening mechanisms that were so far disregarded in the contour modeling must be taken into account. The lifetime of the 2AP chromophore is found to increase dramatically with the number of solvent water molecules, by a factor of four for the 1A complex and by a factor of 16 for the 2A cluster.

The fluorescence lifetimes of 2-pyridone (2PY) and of four different (2PY)_n clusters were determined with the ps streak camera setup. The 2PY monomer has the shortest fluorescence lifetime with 7.80 ns, while the dimer has the longest lifetime of 13.2 ns. The two trimers have a similar lifetime with 11.7 ns for isomer B and 11.2 ns for isomer A. The fluorescence lifetime of the tetramer is even shorter with 10.0 ns.

Received: January 17, 2014

- [1] A. J. Campillo, V. H. Kollmann, S. L. Shapiro, *Science* **1976**, 193, 227.
- [2] A. Lauberau, *J. Chem. Phys.* **1975**, 63, 2262.
- [3] W. Kaiser, A. Laubereau, *Chem. Phys.* **1979**, 6, 313.
- [4] M. Iannone, B.R. Cowen, R. Diller, *Applied Optics* **1991**, 30, 5247.
- [5] R. M. Hochstrasser, D. S. King, A. C. Nelson, *Chem. Phys. Lett.* **1976**, 42, 8.
- [6] R. M. Hochstrasser, D. S. King, *J. Am. Chem. Soc.* **1975**, 97, 4760.
- [7] P. M. Felker, W. R. Lambert, A. H. Zewail, *J. Chem. Phys.* **1982**, 77, 1603.
- [8] J. S. Baskin, A. H. Zewail, *J. Chem. Phys.* **1989**, 93, 570.
- [9] J. C. Williamson, J. M. Cao, H. Ihee, H. Frey, A. H. Zewail, *Nature* **1997**, 386, 159.
- [10] M. Kayano, T. Ebata, Y. Yamada, N. Mikami, *J. Chem. Phys.* **2004**, 120, 7400.
- [11] Y. Yamada, T. Ebata, M. Kayano, N. Mikami, *J. Chem. Phys.* **2004**, 120, 7410.
- [12] K. L. Reid, *Int. Rev. Phys. Chem.* **2008**, 27, 607.
- [13] S. Lobsiger, R. K. Sinha, M. Trachsel, S. Leutwyler, *J. Chem. Phys.* **2011**, 134, 114307.
- [14] R. K. Sinha, S. Lobsiger, S. Leutwyler, *J. Phys. Chem. A* **2012**, 116, 1129.
- [15] S. Lobsiger, R. K. Sinha, S. Leutwyler, *J. Phys. Chem. B* **2013**, 117, 12410.
- [16] S. Lobsiger, R. K. Sinha, S. Blaser, H.-M. Frey, S. Leutwyler, to be published.
- [17] A. Held, B. B. Champagne, D. W. Pratt, *J. Chem. Phys.* **1991**, 95, 8732.
- [18] A. Held, D. W. Pratt, *J. Chem. Phys.* **1992**, 96, 4869.
- [19] C. G. Heid, Diploma thesis, Dept. für Chemie und Biochemie, Universität Bern, **2008**.
- [20] S. Blaser, P. Ottiger, S. Lobsiger, H.-M. Frey, S.