

## Automatic Generation Control for Interconnected Hydro-Thermal System With the Help of Conventional Controllers

Vikram Kumar Kamboj\*\*, Krishan Arora\*, Preeti Khurana\*

\*\* Assistant Professor & Head of Department, EEE, CT Institute of Technology, Jalandhar, Punjab

\* Assistant Professor, Department of Electrical Engineering, Lovely Professional University, Punjab

### Article Info

#### Article history:

Received Mar 13, 2012

Revised Jun 14, 2012

Accepted Jul 29, 2012

#### Keyword:

Automatic Generation Control

Classical Controller

Integral Control

Proportional Control

### ABSTRACT

The Problem of Automatic Generation Control of large interconnected multi-area system is necessitated by the importance of maintenance of frequency and tie-line flows at their scheduled values. Disturbance in any part of the power system network has its effect on the frequency and tie-line power flows of the entire network. Thus, It is the responsibility of the Power system engineers to ensure that adequate power is delivered to the load reliably and economically so that nominal condition will be re-established.

The Research paper, therefore, aims to represents how nominal value can be achieved by close loop control of real and reactive powers generated in the controllable source of the system with the help of conventional controllers.

Copyright © 2012 Institute of Advanced Engineering and Science.

All rights reserved.

### Corresponding Author:

Vikram Kumar Kamboj

Assistnat Professor and Head of Department

Departement of Electrical and Electronics Engineering,

CT Institute of Technology, Jalandhar, Punjab

Email: kamboj.vikram@gmail.com

## 1. INTRODUCTION

In modern power system network there are number of generating utilities and inter connected together through tie-lines. In order to achieve integrated operation of a power system, an electric energy system must be maintained at a desired operating level characterized by nominal frequency, voltage profile and load flow configuration. In any power system, it is desirable to achieve better frequency constancy than is obtained by speed governing system alone. In an interconnected power system, it is also desirable to maintain the tie line flow at a given level irrespective of the load change in any area. To accomplish this, it becomes necessary to manipulate the operation of main steam valves or hydro gates in accordance with a suitable control strategy, which in turn controls the real power output of the generators. The control of the real power output of electric generators in this way is termed as Automatic Generation Control (AGC). The main aims behind the design of AGC are:

- The steady state frequency error following a step load perturbation should be zero.
- The steady state change in the tie flow following a step load change in an area must be zero
- An automatic generation controller providing a slow monotonic type of generation responses should be preferred in order to reduce wear and tear of the equipment.

The problem of AGC can be subdivided into fast primary control and slow secondary control modes. The fast primary control (governing mechanism) mode tries to minimize the frequency deviations and has a time constant of the order of seconds.

But, primary control cannot guarantee the zero steady state error. The slow secondary control channel (supplementary control), with time constants of the order of minutes, regulates the generation to

satisfy certain loading requirements and contractual tie-line loading agreements. The overall performance of the AGC in any power system depends on the proper design of both primary and secondary control loops.

**2. DYNAMIC MODELING OF INTERCONNECTED HYDRO-THERMAL SYSTEM**

Modern power system normally consists of a number of subsystems interconnected through tie lines. For each subsystem the requirements usually include pitching system generation to system load and regulating system frequency. This is basically known as load-frequency control problem or automatic generation control (AGC) problem.

However the characteristics of the hydro turbine differ from steam turbines in many respects:

- The transfer function of the hydro-turbine represents a non-minimum phase system.
- In a hydro turbine relatively large inertia of water, used as the source of energy, causes a considerable greater time lag in the response of the changes in the prime mover torque to a change in the gate position. Moreover, there is an initial tendency for the torque to change in a direction opposite to that finally produced.
- In hydro turbine the response contains oscillating components caused by the compressibility of the water (and expansion of piping) or by surge tanks.
- The hydro governor is provided with a relatively large temporary droop and long washout time. Modern hydro units are normally equipped with electric governors in which the electronics apparatus is used to perform low power functions associated with speed sensing and droop compensation. The electronic apparatus provides greater flexibility and improved performance in both dead band dead times.
- The typical value of permissible rate of generation for hydro plant is relatively much higher (a typical value of generation rate constraints (GRC) being 270% per minute for raising generation and 360% per minute for lowering generation), as compared to that for reheat type thermal units having GRC of the order of 3% per minute.

**2.1 Dynamic Model of Interconnected Hydro-Thermal System in Conventional Mode of AGC**

The AGC system investigated consists of two generating areas of equal size, area 1 comprising a reheat thermal system and area 2 comprising a hydro system. Hydro system is considered with electric governor. GRC of the order of 3% per min for thermal area and 270% per minute for rising and 360% per minute for lowering generation in hydro area has been considered. Fig.2.1 shows the AGC model with single stage reheat turbine in thermal 16 areas and electric governor in hydro area. The system model is considered for continuous-discrete mode operation. Generally ACE (Area Control Error) signal is not available in continuous form. Generally it is available in sampled form; therefore zero order hold is used before controller. Nomenclature for various symbols is given below. The optimum values of derivative, proportional and integral gains for the electric governor have been taken from the work of Nanda et al. [8].

**2.2. System Model**

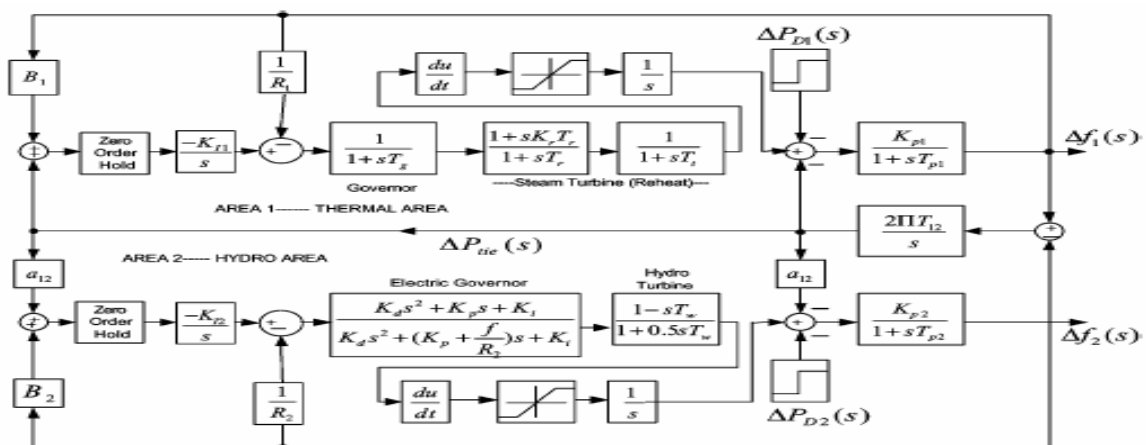

Figure 1. System model for 2 area system

Nomenclature:

F =(Nominal System Frequency)= 60 Hz

$i$  =Subscript referred to area  $i$  (1, 2)  
 $*$  =Superscript denotes optimum value  
 $P_{ri}$  = (Area rated Power)= 2000MW  
 $H_i$  = (Inertia constant)= 5sec  
 $\Delta P_{Di}$  = Incremental load change in area  $i$   
 $\Delta P_{tie}$  = Incremental tie power  
 $D_i = \Delta P_{Di} / \Delta f_i = 8.33 \times 10^{-3}$  Pu MW/ Hz  
 $T_{12}$  = Synchronizing coefficient= 0.086 Pu MW/radians  
 $R_i$  = Governor speed regulation parameter= 2.4 Hz/Pu MW  
 $T_g$  = Steam governor time constant, second= 0.08 sec  
 $K_r$  = Steam turbine reheat constant=0.5  
 $T_r$  = Steam turbine reheat time constant= 10sec  
 $T_t$  = Steam turbine time constant= 0.3 sec  
 $B_i$  = Frequency bias constant= 0.424  
 $T_{pi} = 2H_i / fD_i = 20$  sec  
 $K_{pi} = 1/D_i = 120$ Hz/Pu MW  
 $K_{Ii}$  = Integral gain  
 $K_{Pi}$  = Proportional gain  
 $K_{Di}$  = Derivative gain  
 $K_d, K_p, K_i$  = Electric governor derivative, proportional, and integral gains, respectively  
 $B_i = (D_i + 1/R_i)$ ; area frequency response characteristics= 0.424  
 $T_w$  = Water starting time= 1 sec  
 $ACE_i$  = Area control error of area  $i$   
 $A_{12} = -Pr_1/Pr_2 = -1$   
 $J$  = Cost index

### 3. PROBLEM STATEMENT

For the system mentioned in Fig.1, the aim is to find the best control strategy such that following objectives are met:

1. The steady state frequency error following a step load perturbation should be zero.
2. The steady state change in the tie flow following a step load change in an area must be zero.
3. An automatic generation controller providing a slow monotonic type of generation responses should be preferred in order to reduce wear and tear of the equipment.

When control structure is a major known our objective is to adjust the control parameter so as to achieve the best dynamic performance.

- This is only achieved by proper optimization of controller parameter.

Objective function used for controller design is that which is used in ISE criterion and this is as follows:

$$J = \int_0^t f(e_1^2, e_2^2, e_3^2 \dots e_n^2) dt$$

Where  $e_1, e_2, e_3 \dots e_n$  are different errors.

$$\text{In this case } J = \int_0^t (\Delta f_1^2 + \Delta f_2^2 + \Delta P_{tie}^2)$$

System response with conventional controller:

Here for two area hydrothermal AGC model, we have used ISE criteria to optimize the supplementary controllers. In the AGC model first we have chosen our control structure as integral one.  $\Delta P_{tie}$  (1,2),  $\Delta f_1$  and  $\Delta f_2$  are consider as errors, 1% step load perturbation is consider in either thermal or hydro area. In the beginning consider second area as uncontrolled one and vary the integral controller gain for the first area and observe the performance index  $J$  by simulating the model. Plot performance index Vs Gain and select that value of gain for which performance index is minimum. This is the suboptimal value of controller gain for first area. Similarly follow the same procedure for second area keeping first area uncontrolled and find the suboptimal gain for second area. The value obtained for both areas are suboptimal values on individual basis. However there is a coupling between optimal gains for two areas, which is to be finely tuned.

In the second iteration the controller gains of first area is varied considering suboptimal gain for second area. Take plot for performance index Vs gain and find any change in first area gain for minimum

performance index. Follow the same procedure for second area and carryout little iteration so as to get best values for optimum controller gain for both areas. In same manner we have tuned the parameters of the PI controllers. Tuning of the PID controller has been tried but when we plot the cost function for various values of derivative gain with different values of proportional and integral gain, it has been found that cost function is minimum for derivative gain equal to zero. Therefore PI and PID controller will give the same response. Therefore hereafter we are going to consider only integral and PI controller for dynamic response study.

**4. RESULTS AND ANALYSIS**

**4.1 Simulation model hydro thermal system with PI controller**

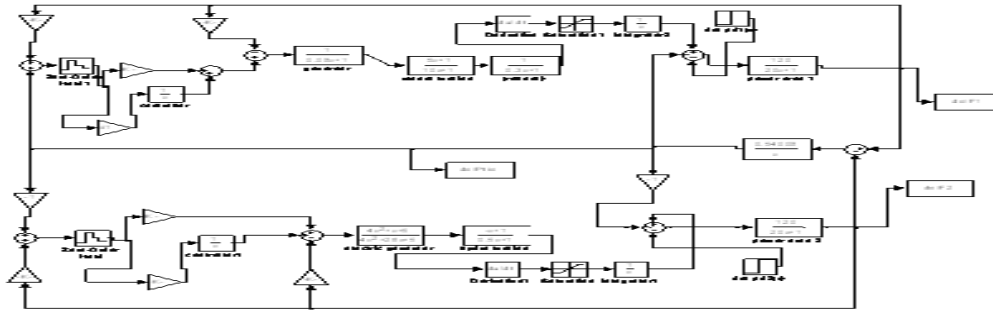

Figure 2. Model of Hydrothermal system

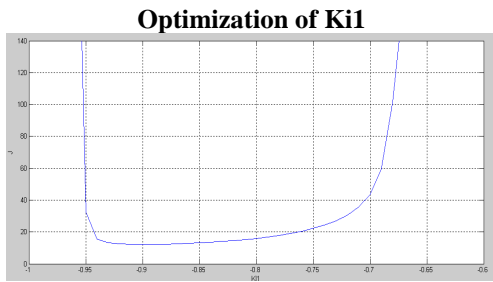

Figure 3. plot of j v/s ki1

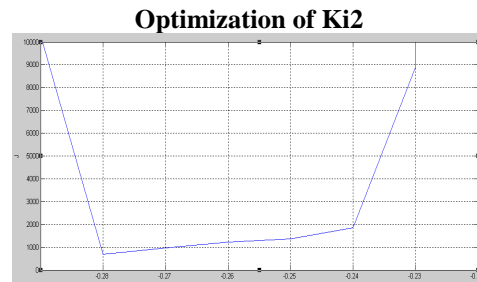

Figure 4. Plot of j v/s ki2

In figure 3, the graph between cost index ( j ) and integral controller (ki1) then choose the value of ki1 for optimum value of cost index (j) . in this case we can choose the value for ki1=-0.94

In figure4, the graph between cost index ( j ) and integral controller (ki2) then choose the value of ki2 for optimum value of cost index (j) . in this case we can choose the value for ki2=-0.28

**4.2.5 Optimum value of Integral Controller for different Sampling Time:**

We will use the optimum value of integral controller gains for the thermal area one and hydro area two are found to be Ki1= -0.041 and Ki2= -0.012.

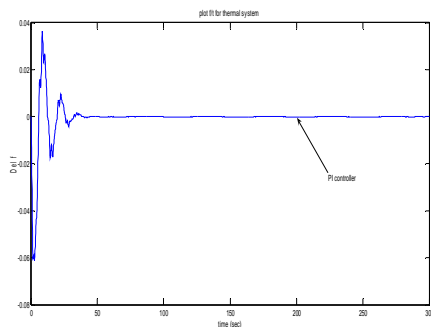

Figure 5. Variation in frequency for 1% step load change in thermal area

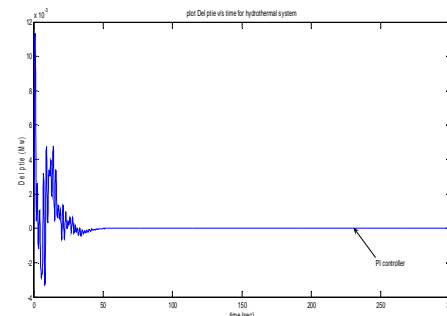

Figure 6. Variation of frequency for 1% step load change in hydro area

In figure 5, the value find out of pi controller  $kp1=-0.061$  and  $ki1=-0.43$  and  $kp2=-0.11$ ,  $ki2=-0.15$ , this graph shows the effect of pi controller on frequency change in thermal area

In figure 6, the value find out of pi controller  $kp1=-0.061$  and  $ki1=-0.43$  and  $kp2=-0.11$ ,  $ki2=-0.15$ , this plot shows variation in frequency for hydro area

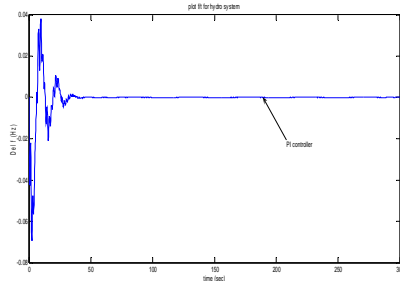

Figure 7. Variation in tie flow when 1% step load change in area 2

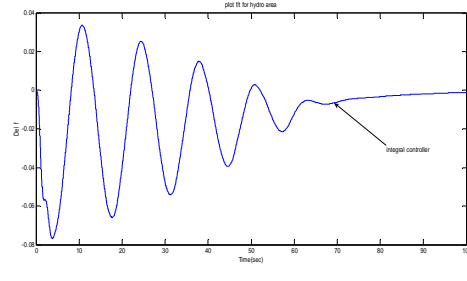

Figure8. Variation of frequency for 1% step load change in hydro area

In figure 7, the value find out of pi controller  $kp1=-0.061$  and  $ki1=-0.43$  and  $kp2=-0.11$ ,  $ki2=-0.15$ , this plot shows variation in power (ptie) for hydro area

In figure 8, the value find out of integral controller  $ki1=-0.041$  and  $ki2=-0.012$ , this plot shows variation in frequency for hydro area .

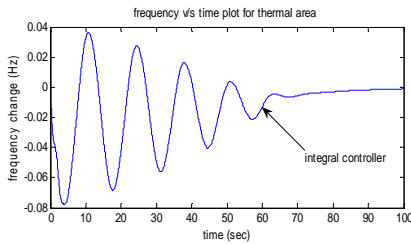

Figure 9. Variation of frequency for 1% step load change in thermal

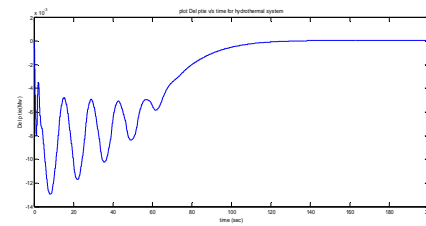

Figure 10. Variation in tie flow when 1% step load change in area 1

In figure 9, the value find out of integral controller  $ki1=-0.041$  and  $ki2=-0.012$ , this plot shows variation in frequency for thermal area.

**Comparison of pi and integral controller for Thermal/Hydro area:**

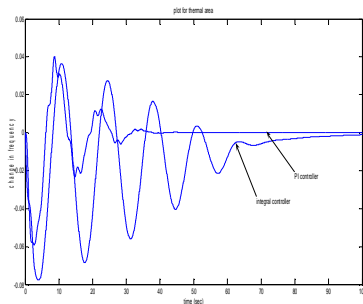

Figure 11. Variation in frequency in thermal area for different controller

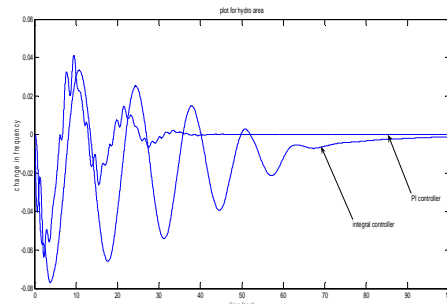

Figure 12. Variation in frequency in hydro area for different controll

**5. CONCLUSION**

- Dynamic responses with PI controller are better than the Integral controller regarding peak deviation and settling time.

- Response of integral controller is smooth while response of PI controller is somewhat jerky (which is undesirable considering governor point of view).
- Dynamic response of controllers optimized through classical computational technique and genetic algorithm yields more or less response.

## REFERENCES

1. C. Concordia, L. K. Kirchmayer, "Tie-Line Power & Frequency Control of Electric Power Systems", AIEE Trans., vol. 72, part III, 1953, pp. 562-572.
2. C. Concordia, L. K. Kirchmayer, "Tie-Line Power & Frequency Control of Electric Power Systems- Part II", AIEE Trans., vol. 73, part III-A, 1954, pp. 133-141.
3. L. K. Kirchmayer, "Economic Control of Interconnected Systems", John Wiley, New York, 1959.
4. O. I. Elgerd, C. E. Fosha, "Optimum Megawatt Frequency Control of Multi-area Electric Energy Systems", IEEE Trans. on Power Apparatus and Systems, vol. PAS-89, No.4, Apr. 1970, pp. 556-563.
5. C. E. Fosha, O. I. Elgerd, "The Megawatt Frequency Control problem: A New Approach via Optimal Control Theory", IEEE Trans. on Power Apparatus and Systems, vol. PAS-89, No.4, Apr. 1970, pp. 563-574.
6. Nathan Cohn, "Some Aspects of Tie-Line Bias Control on Interconnected Power Systems", AIEE Trans., vol. 75, Feb. 1957, pp. 1415-1436.
7. Nathan Cohn, "Control of Generation & Power Flow on an Interconnected Power Systems", John Wiley, New York, 2nd Edition, July 1971.
8. IEEE Committee Report, "IEEE Standard Definition of Terms for Automatic Generation Control of Electric Power Systems", IEEE Trans. Power Apparatus and Systems, vol. PAS-89, Jul. 1970, pp. 1358-1364.

## BIOGRAPHIES OF AUTHORS



Vikram Kumar Kamboj is Presently working as Assistant Professor and Head of Department in Electrical and Electronics Engineering in CT Institute of Technology, Jalandhar (Punjab). He has completed his B.E. (Instrumentation & Control) from Maharishi Deyanand University, Rohtak and M.Tech (Power System Engineering) from Rajasthan Technical University, Kota and currently pursuing Ph.D (Electrical Engineering) from Punjab Technical University, Jalandhar. His area of research is Power System Planning and Optimization, Unit Commitment Problem in Electrical Power System and Power System Operation and Control



Krishan Arora is presently working as Assistant Professor in the Department of Electrical and Electronics Engineering in Lovely Professional University, Phagwara (Punjab). He has completed his B.Tech (Electrical & Electronics Engg.) from Punjab Technical University, Punjab and M.Tech (Electrical Engg.) from Punjab Technical University, Punjab



Preeti Khurana is presently working as Assistant Professor in the Department of Electrical and Electronics Engineering in Lovely Professional University, Phagwara (Punjab). She has completed his B.Tech (Electrical Engg.) from Punjab Technical University, Punjab and M.Tech (Electrical Engg.) from Punjab Technical University, Punjab