

Development of Wireless Patient's Vital Sign Monitor Using Wireless LAN (IEEE.802.11.b/g) Protocol

Achmad Rizal*, Vera Suryani**, Jondri**, Sugondo Hadiyoso***

*School of Electrical Engineering, Telkom University, Indonesia

**Telkom School of Computing, Telkom University, Indonesia

***Telkom Applied Science School, Telkom University, Indonesia

Article Info

Article history:

Received Jun 26, 2014

Revised Oct 3, 2014

Accepted Oct 17, 2014

Keyword:

Body temperature

ECG

PPG

Vital sign monitor

Wireless LAN

ABSTRACT

Vital sign monitor is typical medical instrument for basic physiological measurement. Medical practitioner assesses a patient's health condition by observing measurement results shown in display. In this research, we designed low cost, wireless, PC-based vital sign monitor. Signals captured in designed vital sign monitor are electrocardiogram (ECG), photoplethysmogram (PPG), and body temperature. Captured data are transmitted via wireless LAN module so that medical practitioner is able to monitor patient's condition remotely from another room or place. The system worked well for maximum transmission distance about 45 meters for LOS condition and 20 meter for NLOS condition.

Copyright © 2014 Institute of Advanced Engineering and Science.
All rights reserved.

Corresponding Author:

Achmad Rizal,

School of Electrical Engineering, Telkom University,

Jalan Telekomunikasi, Terusan Buah Batu, Bandung 40257 Indonesia

Email: achmadrizal@telkomuniversity.ac.id

1. INTRODUCTION

One of most popular medical devices used in intensive care unit (ICU) room is vital sign monitor, known also as multi-parameter patient monitor. This device is used to monitor patient condition by measuring patient bio-signal such electrocardiogram (ECG), respiration rate, non-invasive blood pressure, blood oxygen saturation (SpO₂) and body temperature. By looking at these signals, a medical practitioner can assess the condition of a patient thus any immediate action can be taken if emergency situation occurs [1].

The vital sign monitor units are usually in the form of hardware installed in the patient's body with a screen placed at the patient's bedside. To see the condition of the patient, the medical practitioner should go to the patient's bed to see the results of the measurement signal such patients. Each unit is typically high-priced that only affordable by large hospitals.

Considering the above situation, this study seeks to develop a low-cost wireless vital signs monitor device. The device consists of a hardware to acquire signals from the patient and a software to show signal measurement results. On the hardware, a transmission modules using wireless LAN protocols (802.11b) is added so that measurement data can be transmitted over a wireless network. The transmitted signals can be received on a personal computer or laptop that has been fitted with the software created. With this system, it is expected that medical practitioners no longer need to go into ICU room too often to see patient's vital signs because the signal can be monitored from outside the patient's room or medic's office.

Several wireless vital sign monitor had been develop using different transmission protocol. ZigBee is a protocol that is often used for vital sign monitors data [2]. Zigbee has relatively low power consumption making it suitable for low bit rate data transmission [3] [4]. Some research prefer using wireless LAN for

vital sign data transmission [5] [6]. This is due to the wireless LAN device is a device that is almost always present in the PC, mobile phone or other communication device. So it does not need additional devices such as Zigbee. Farther transmission distance also being considered as a selection of wireless LAN data transmission protocol.

In this research, we develop PC-based wireless LAN vital signs monitor. Measured signal are ECG, PPG and body temperature. We expected to obtain a reliable but more affordable vital signs monitor with high mobility that can be used for community health center or small hospital in Indonesia.

2. BASIC THEORY

2.1. Vital Sign Monitor

Vital sign monitor is a device for measuring vital signals of patients such as non-invasive blood pressure (NIBP), oxygen saturation (SPO₂), number of heartbeats (pulse rate), ECG and temperature [7]. The 4 possible device only measures 4 signals while the most complex signals can measure up to 8 signals with additional signals respiration, EEG signals, EOG and respiratory airflow. In this study, we built vital sign monitor that capable of measuring vital signs ECG signal, photoplethysmogram, the number of heartbeat rate, and body temperature.

2.2. ECG

ECG signal is a signal generated by the heart as the representation of the electrical activity of the heart. Examining the ECG signal allows a medical practitioner to know a person's level of cardiovascular health. ECG signals are assessed from the shape, orientation and rhythm [8]. ECG signal shape appears as in Figure 1:

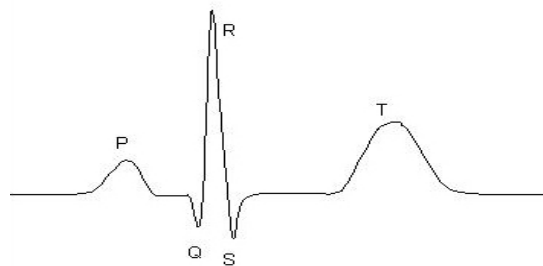

Figure1. ECG signal

Each wave of the ECG signal is expressed as follows [9]:

1. P wave occurs due to atrium depolarization.
2. QRS complex occurs due to ventricular depolarization process.
3. T wave occurs due to ventricular repolarization.
4. PR interval indicates the time of onset of atrium contraction to the beginning of ventricular contraction.
5. RT intervals shows muscle contraction (systole ventricle), and
6. TR interval shows muscle relaxation (diastole ventricle).

A pair of electrode, or combination of several electrodes, attached in the body to captured ECG signal, is called lead. The technique which is often used for a lead to capture ECG signals on ECG monitoring is Einthoven triangle. The placement of the electrodes to take ECG signal from body using Einthoven's triangle is shown in Figure 2.

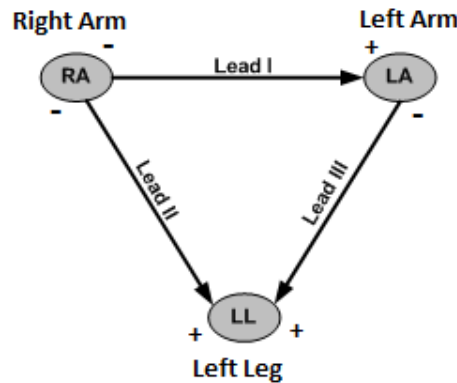

Figure 2. Einthoven triangle

On Einthoven's triangle, there are three point lead, i.e lead I, lead II and lead III. Lead I is the potential difference between the left arm and right arm. Lead II is the potential difference between the left leg and right arm. Lead III, is the potential difference between the left-hand leg and left arm. Meanwhile right leg serves as a ground to reduce noise.

2.3. Photoplethysmograph (PPG)

Photoplethysmograph (PPG) is a technique for measuring changes in the volume of a body part/organ by utilizing optical phenomena [10]. PPG is used in this study to measure changes of blood volume in patient's finger to monitor the blood pumping activity of the patient's heart. Information taken from the PPG signals can be used to count the number of heartbeats. There are 2 modes that can typically be used, namely the transmission mode and PPG reflection mode [11]. Each configuration mode can be seen in Figure 3. In this research we used PPG reflection mode.

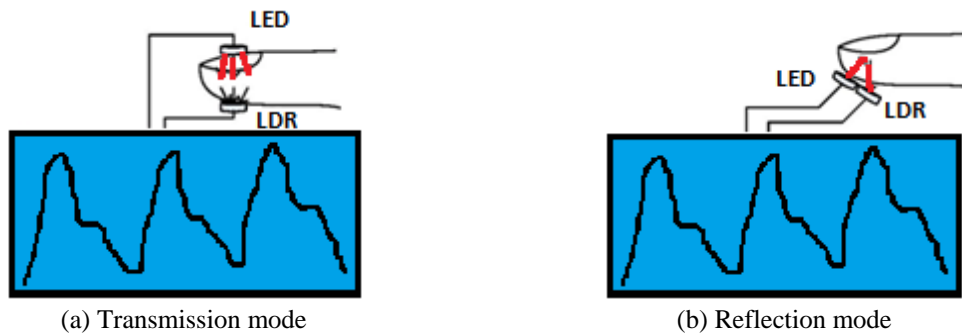

Figure 3. PPG sensor configuration mode

2.4. Wireless LAN

Wireless local area network (LAN) 802.11b standard is the first wireless LAN technology that has data speeds up to 11 Mbps [12]. The transfer speed is affected by distance between the sender and the recipient, and whether there is any obstacle between them. The 802.11b standard uses the 2.4 GHz frequency which is freely used for industrial, research, and medical (ISM) purposes. The maximum transmit power allowed by this standard is 100mW.

3. RESEARCH METHOD

3.1 System Design

The system designed in this research is as shown in Figure 4. The system consists of two parts, i.e. hardware part with wireless LAN module as the sender and software part for signal viewer at the receiver. At

the sender, the signal being measured are ECG, PPG and temperature. The three signals are acquired, then multiplexed in microcontroller, and formatted to fit the data format wireless LAN module. Information to be displayed on the receiver are the ECG signal, PPG, temperature and heart rate that are calculated from the PPG signal.

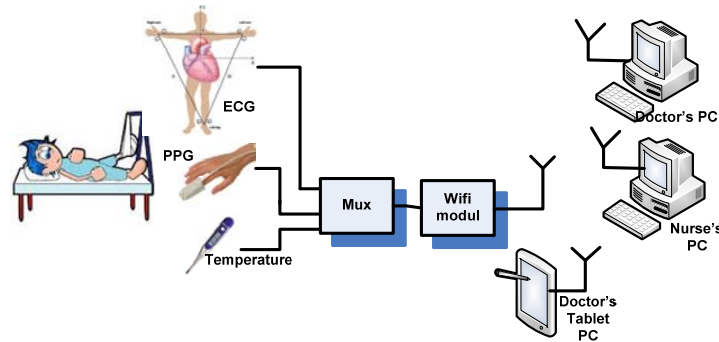

Figure 4. System design

3.2 ECG Subsystem

The electrodes are used as sensors to acquire ECG signals. Output signals from electrodes are amplified by bio-potential amplifier using AD620 [13]. Furthermore, the signal is filtered using band-pass filter (BPF) of 0.05-40Hz. In next phase, the signal is amplified and filtered using a low-pass filter (LPF) 20Hz. In the final stage, the signal level is raised using clamper so as to allow the signal amplitude in the range of 0 - 5 volts. Block diagram of ECG devices are displayed as in Figure 5.

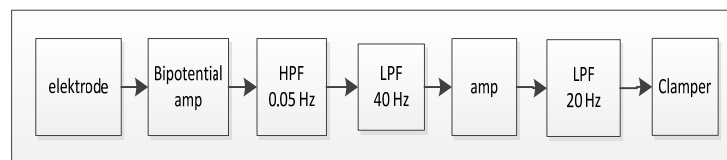

Figure 5. Block Diagram of ECG Device

3.3 PPG Subsystem

Reflection mode PPG sensor is used to capture PPG signal. Output signal from the sensor is filtered using HPF to remove low-frequency noise. Furthermore, the signal is amplified by a first amplifier up to 26 times. In the next phase of the signal is filtered using a low-pass filters (LPF) 20Hz and the voltage level is raised using the adder. PPG device block diagram in presented in Figure 6.

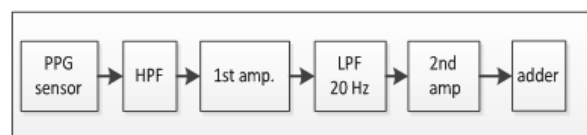

Figure 6. Block diagram of PPG device

3.4 Microcontroller and Wireless LAN Module

Microcontroller used in this study is ATMEGA16 with integrated analog-to-digital converter (ADC). The microcontroller combines three signals and changes their formats into serial form that can be transmitted over the wireless LAN module. The microcontroller circuit used is shown in Figure 7.

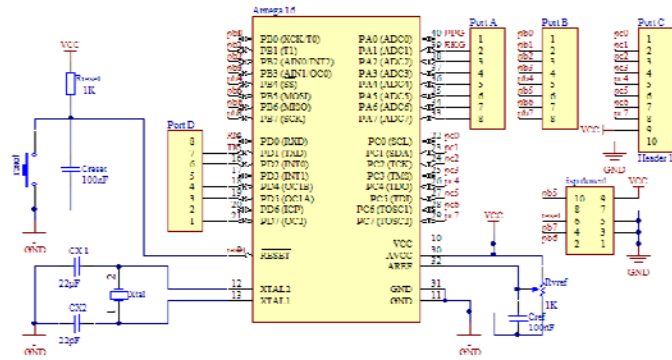

Figure 7. ATMEGA16 circuit

Wireless LAN module that is used in this study is Wiz610wi from Wiznet [14]. This module serves to change the format the microcontroller serial data output into appropriate data format to be sent over the wireless LAN protocol. This module supports up to 230,400 bps serial communication and can communicate point to point with a PC without using access points.

3.5 Software Subsystem

The software receives data, perform signal demultiplexing, and display the signal measurement results. For ECG and PPG, the measurement results are displayed in graphical form, while the temperature data and calculation of the heartbeat rate are displayed in numeric. Flowchart of the software is as shown in Figure 8.

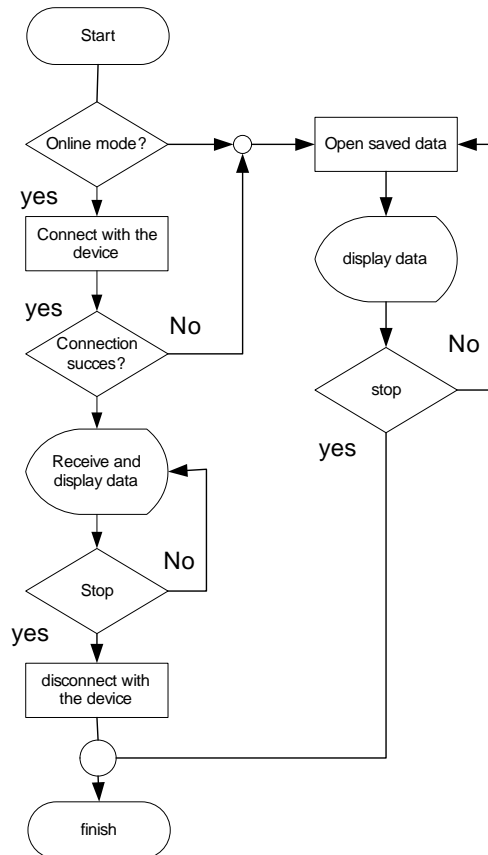

Figure 8. Program flowchart

4. RESULTS AND ANALYSIS

4.1. ECG, PPG and Temperature Blocks Measurement Result

We used Fluke PS400 ECG signal generator as input for ECG device and took PPG signal directly from body [15]. The output signals were as shown in Figure 9. Figure 9 shows the ECG and PPG signals that were directly taken from the patient's body. Both of these signals are noise-free and their basic forms were clearly visible. It can be concluded that the analog signal acquisition device worked well.

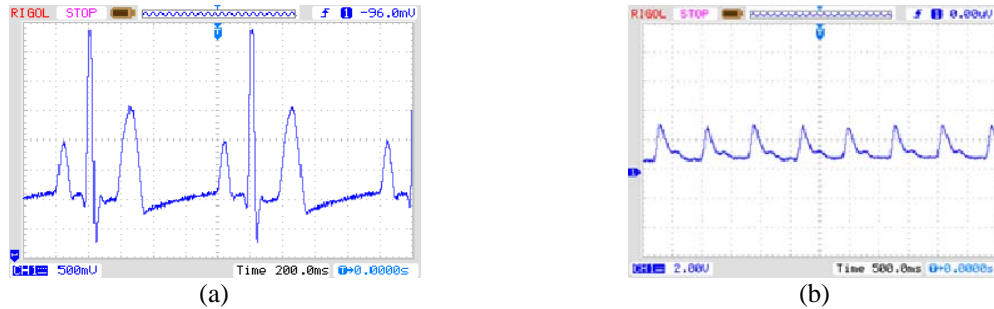

Figure 9. (a) ECG signal (b) PPG signal

Testing results showed that accuracy for temperature measurement using LM35 sensor reached 98,16%. From this measurement result, the signal acquisition part had been functioning properly.

2.1. Microcontroller and Wireless LAN Module Testing

Microcontroller combined the three signals of ECG, PPG, and body temperature, then transmitted the data via wireless LAN module to PC. To verify that those signals were transmitted correctly, we rechecked the received data in hyperterminal application. Figure 10 showed the reading of data transmitted by the hardware. The first column is PPG data, the second column is ECG data, and the third is temperature data.

```

contoh data.txt - Notepad
File Edit Format View Help
PPG EKG Suhu
100 156 202
113 144 212
123 154 205
114 164 212
145 132 215
133 133 208
142 125 216
143 135 212
153 128 209
153 145 205
156 158 207
156 157 208
153 153 202
167 159 205
163 154 215
164 157 195
165 162 198
168 164 193
173 163 192
175 166 193
176 167 195
175 168 185
179 172 193
185 175 195]

```

Figure 10. Data format in txt form

4.2. Application Testing

Figure 11 shows the application in PC to display vital sign data. ECG and PPG signal are displayed as graphic; meanwhile body temperature and heart rate are showed in numeric. We use the same GUI display with our previous work [16]. ECG and PPG signals are displayed appropriately with standard signal so we can say that the application work well. Accuracy of body temperature measurement reaches 98,27% and for heart rate reaches 99,88%.

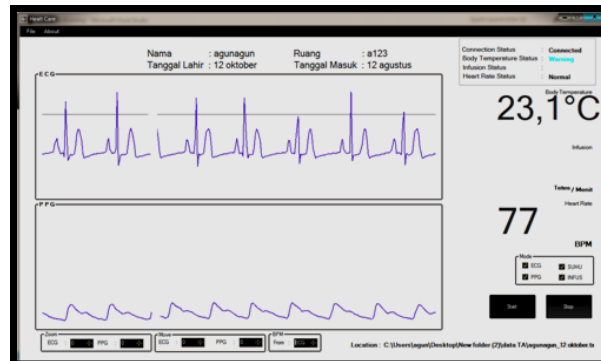

Figure 11. Application display

4.3. Transmission Distance Testing

One feature designed in the device is wireless data transmission. Transmission distance was tested to see how far data could be received by the receiver. To ensure the quality of the received signal, we measured several parameters such as delay and jitter. Delay can be formulated as follows [17]:

$$\text{delay (s)} = \frac{\text{number bits sent}}{\text{Throughput}} \quad (1)$$

While throughput was formulated as follow [16]:

$$\text{Throughput} = \frac{\text{number bits sent}}{\text{total delivery time}} \quad (2)$$

Jitter is the variation in delay that occurs in the network [17]. If the value the greater the network performance is getting worse. Jitter formulated as follows:

$$\text{average delay(s)} = \frac{\text{delay(s)}}{\text{Total delivery packet}} \quad (3)$$

$$\text{Jitter (s)} = \text{delay} - \text{average delay} \quad (4)$$

Measurements were taken at two scenarios i.e. conditions of line of sight (LOS) and non- line of sight (NLOS). From the measurements, the obtained results were as presented in Table 1 and Table 2.

Table 1. Measurement in LOS condition

| Distance (m) | Delay (ms) | Jitter (ms) |
|--------------|------------|-------------|
| 15 | 9,5 | 0,95 |
| 30 | 13,2 | 1,7 |
| 45 | 15,07 | 2,4 |

Table 2. Measurement in NLOS condition

| Distance (m) | Delay (ms) | Jitter (ms) |
|--------------|------------|-------------|
| 10 | 15,5 | 2,6 |
| 20 | 16,7 | 2,7 |

Tables 1 and 2 showed that the LOS condition was reached at distance of maximum 45 meters, while in NLOS conditions the farthest distance was only 20 meters. Jitter and delay values generally still meet the requirements established for wireless network standard [17].

5. CONCLUSION

Based on the implementation and testing the system, four conclusions can be drawn from this study. First, the device successfully measures ECG, PPG and temperature simultaneously. Second, the farthest transmission distance for LOS condition is 45 meters, while for NLOS condition is 20 meters. Third, application in the receiver can display the received data correctly. Last, the accuracy of temperature measurement reaches 98,27 % while heart rate measurement reaches 99,88 %.

Next research will extend the connection from point-to-point to point-to-multipoint view. This means we only need less devices for efficient data transmission in patient's vital sign.

REFERENCES

- [1] _____, "Vision Care 330i," [online] available at <http://www.acma-medical.com/product.php?category=6> [accessed, February, 2013]
- [2] Koceski, Saso, et al., "Continuous real-time monitoring of patient's vital signs based on ZigBee standard", *International Journal of Informatics and Communication Technology (IJ-ICT)*, 3.2, 2014.
- [3] V. Suryani and A. Rizal, "Feasibility Analysis of Zigbee Protocol in Wireless Body Area Network", *International Conference on Soft Computing, Intelligent System and Information Technology (ICSIT)*, 2010, pp. 436-438
- [4] Huang, Xin-bo, et al., "Research on Zigbee Network Temperature Sensor in Intelligent High-Voltage Switch Cabinet", *TELKOMNIKA Indonesian Journal of Electrical Engineering*, 12.7, 2014.
- [5] Lin, Yuan-Hsiang, et al., "A wireless PDA-based physiological monitoring system for patient transport", *Information Technology in Biomedicine, IEEE Transactions on*, 8.4 (2004): 439-447.
- [6] Rizal, A, et. al, "Development of Multisignal Remote Patient Monitoring System for Heart Patient using Android Based Tablet PC and WirelessLAN (IEEE.802.11.B/G)", *Jurnal Penelitian & Pengembangan Telekomunikasi, ITTelkom*, Vol 17 June 2012.
- [7] E. Institute, "Vital Signs Vital Signs Monitoring", *Health Device* vol. 40, no. 9, 2011.
- [8] S. Widjaya, "EKG Praktis", Binarupa aksara, Jakarta, 1990.
- [9] W. J. Tompkins, "Biomedical Signal Processing", Prentice Hall, New Jersey, 1993
- [10] J. G. Webster, "Medical Instrumentation Application and Design", John Wiley & Son, Inc, New York, 1998
- [11] S. Hadiyoso, A. Rizal, and R. Magdalena, "Monitoring Photoplethysmograph using Wireless LAN (802.11b)", *Preceeding KNS&I 2011* vol. 1, pp. 89-93, 2011.
- [12] IEEE Standard for Information technology, IEEE Std 802.11™-2 2012
- [13] _____, "Datasheet AD620," [online] available at http://www.analog.com/static/imported-files/data_sheets/AD620.pdf, [accessed May 2013]
- [14] _____, "Datasheet WIZ619wi," [online] available at http://www.wiznet.co.kr/en/WIZ610wi_Quick_Installation_Guide_Eng_.pdf [accessed July 2013]
- [15] Fluke. Biomedical, "PS400 Patient Simulator, Operator Manual", [online] available at http://assets.fluke.com/manuals/ps400__omeng0000.pdf
- [16] Fikar, A. R., et al. "PC Based Wireless Vital Sign Monitor Using Zigbee Communication", *The 15th International Conference on Biomedical Engineering*. Springer International Publishing, 2014.
- [17] Tellabs, "Quality of Service in the Wireless Backhaul", [online] available at <http://www.tellabs.com/resources/papers/tlabqoswirelessbackhaul.pdf> [accessed April 2013]

BIOGRAPHIES OF AUTHORS

Achmad Rizal received Master degree in Biomedical Engineering from Institut Teknologi Bandung, Bandung, Indonesia in October 2006. He joined as a Lecturer in the Department of Electrical Engineering of Telkom University, in 2001. He is currently members of Biomedical Instrumentation Research Group in Telkom University. His research interests include biomedical signal processing, biomedical image processing, biomedical instrumentation and telemedicine. He is member of IEEE EMB society.



Vera Suryani received Master degree in Information Technology from Insitut Teknologi bandung, Indonesia in 2009. She joined as a Lecturer in the Department of Informarics of Telkom University, in 2003. She is currently members of Unified Communication in Telkom University. Her research interests include wireless sensor network, distributed system, and internet of things.



Jondri received Master degree in Mathematics from Bandung Institute of Technology in 1999. He has been joined as a Lecturer at department of Informatic Telkom University in 1995. His research interests are machine learning, biomedical engineering, and finance mathematics.



Sugondo Hadiyoso received Master degree in Electrical-Telecommunication Engineering from Telkom University, Bandung, Indonesia in March 2012. He joined as a Lecturer in the Department of Electronics and Communication Engineering of Telkom University, in 2010. He is currently members of Biomedical Instrumentation Research Group in Telkom Univesity. His research interests include wireless sensor network, embedded system, logic design on FPGA and biomedical engineering.