

## A Novel Three Phase Multilevel Inverter with Single DC Link for Induction Motor Drive Applications

A. Ramesh<sup>1</sup>, O. Chandra Sekhar<sup>2</sup>, M. Siva Kumar<sup>3</sup>

<sup>1,2</sup>Koneru Lakshmaiah Education Foundation, Guntur, India

<sup>3</sup>Head of the Department, Gudlavalleru Engineering College, Gudlavalleru, AP, India

---

### Article Info

#### Article history:

Received Aug 16, 2017

Revised Nov 25, 2017

Accepted Dec 5, 2017

#### Keyword:

Induction motor drive

Multi level inverter (mli)

Reduced switch count

---

### ABSTRACT

All industrial drives need a controlled output and it can be achieved by controlling the input supply. In this regard, the inverter circuit plays an important role in the applications of industrial drives. The industrial drives are operated at high rated power and the conventional inverters cannot be applicable for high power demands because of the large  $dV/dt$  (rate of change of voltage) and more switching losses. Therefore, multilevel inverters are introduced for high power-medium voltage applications. For all AC drives the MLIs are reliable in operation. This MLI topology also reduces the harmonics and bearings stress of a motor with low  $dV/dt$ . In most applications multilevel inverters are used because we can get more number of voltage levels. To increase the number of voltage levels, circuit needs to have more switches. But, we have to optimize the switch count and switching operations. The power level of the inverter is limited due to high currents and stress. In this paper, we proposed a new circuit topology which enables the switches to be active at different voltage levels, causes reduction of the switching losses and also increases the efficiency of the inverter. In this we have presented two configurations for an eleven level MLI for three phase induction motor drive application. In this an individual DC source is connected for each bridge circuit of each phase in one configuration and only one common DC link is used for three phases in another configuration. With this the size, cost and complexity could be decreased. In both the configurations the controlled output of the inverter is connected to the induction motor drive. The circuits are modeled using Matlab/simulink software and corresponding output waveforms are analyzed for both configurations.

Copyright © 2018 Institute of Advanced Engineering and Science.  
All rights reserved.

---

### Corresponding Author:

A. Ramesh,

Departement of Electrical and Electronics Engineering,

Koneru Lakshmaiah Education Foundation,

Guntur, India.

Email: rameshadireddy007@gmail.com

---

## 1. INTRODUCTION

In most of the industries, the need of variable speed motor drives is fulfilled by induction motors for so many years. Because, induction motors are simple and rugged in construction with an easy maintenance. All variable speed drives require variable input supply. The MLIs are used for this purpose. Because of its own advantages, it has got its popularity in the variable drive applications [1], [2]. In most of the industries the motors used are high power rating. To satisfy this need the MLI are popular for high power and medium voltage drives. The MLI has the following advantages.

- a. The total harmonic distortion (THD) is less.
- b. Switching losses are less.

- c. Power quality improves.
- d. Decreased electromagnetic interference (EMI).
- e. The voltage stress on each switch would be decreased [3], [4].

MLI consist of voltage sources with switches, diodes and capacitors. These components are connected and switches are controlled to generate the output voltage with more number of levels. Manufacturing industries are using these MLI and the people treating it as a one of the new power converter fields [5], [6], since they are limiting the disadvantages of existing inverters. These MLIs are of three types: (a) diode clamped inverter (b) flying capacitor type and (c) cascaded H-bridge topology. Among these topologies, the cascaded H-Bridge multi level inverter [7] topology is frequently used. The remaining two types of inverters have disadvantages like high cost because circuit requires more components and complexity in operation when compared to the cascaded multilevel inverter. Using H-bridge circuit the number of voltage levels can be increased with minimum DC voltage sources. The rate of change of voltage ( $dV/dt$ ) is also less which causes low electromagnetic interference. However, these cascaded H-Bridge MLIs also have some drawbacks. To increase the count of voltage levels in the output voltage, circuit requires more number of switches, and gate driving circuits also increases. This results an increase in cost and complexity again. Therefore, we have to consider the switch count while implementing this topology. The optimized design is that it should have less number of switches for more voltage levels.

In this paper, a new configuration is proposed for an eleven level output voltage with reduced switch count. This configuration gives hybrid H-Bridge multilevel inverter. In this configuration, the diode bridge circuit is connected at source side along with H-Bridge circuit. Because of this diode bridge circuit the bidirectional operation is possible. For an eleven level output voltage the proposed configuration requires 8 switches in each phase, where as cascaded H-bridge topology requires 20 switches in each phase. In this proposed topology, during the operation if any voltage cell has failure due to any reason, there would be no discontinuity in the inverter operation. But, it operates at low power levels [8]. This is an additional feature for this configuration. The modularity of this inverter allows operation for high voltage and high power applications. Using this, a three phase inverter circuit has been made and is connected to three phase induction motor [9]. Here each phase consist of a separate DC link voltage source.

Another configuration is also proposed with a single common DC link voltage source for each phase [10]. In both the configurations, the induction motor drive is connected to the inverter circuit and the performance characteristics of the drive such as speed, torque and stator current are analyzed. In this the two configuration circuits are modeled by using Matlab /simulink software and corresponding results are displayed.

## 2. PROPOSED 3-PHASE MLI CIRCUIT WITH REDUCED NUMBER OF SWITCHES FOR INDUCTION MOTOR APPLICATIONS CONFIGURATION-1

The Figure 1 represents the circuit diagram of configuration-1 for a three phase hybrid H-bridge eleven level inverter with a separate DC link voltage source for an each phase. From this configuration it is observed that, the total number of switches required for three phases are 24. And for an individual phase the switch count is 8 only. For the same eleven levels of output voltages, the conventional cascaded H-bridge inverter topology requires twenty switches for individual phase. Here the switch count is reduced to 60% of the count in conventional cascaded H-bridge configuration. In the proposed circuit at any time only two switches are operating to get the desired output voltage level. This is because of bidirectional operation of switches caused by a diode bridge circuit. The three units of hybrid H-bridges are connected, such that the output voltage of each unit is phase displaced by 120 degrees each. This three phase voltage is given as input to induction motor.

The Table 1 represents the switching sequence of an eleven level hybrid H-Bridge MLI. From this table we could observe that, only two switches are operating at any time. For instance consider for  $3V_{dc}/5$  voltage level the switches  $S_2$  and  $S_6$  are operating and for  $-V_{dc}/5$  voltage level the switches  $S_3$  and  $S_5$  are operating. Therefore, the number of gate driving, protection circuits and the stress on switches also decrease.

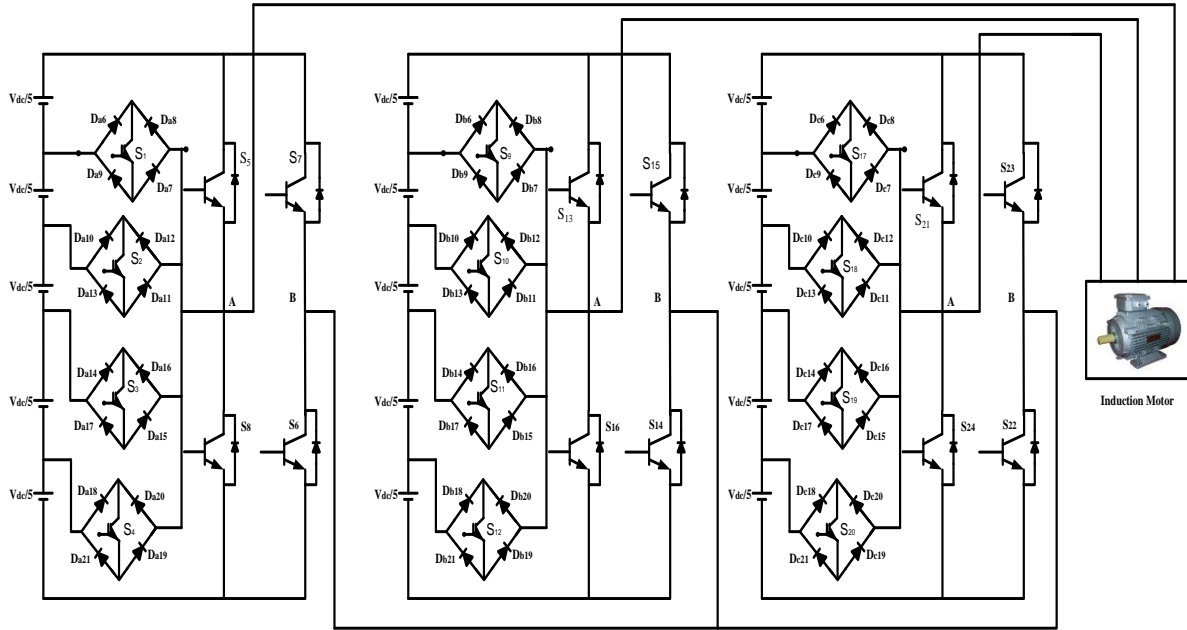

Figure 1. Three phase eleven levels MLI fed to induction motor

Table 1. Switching sequence for eleven level hybrid H-ridge

Voltage level	Switching operation							
	S <sub>1</sub>	S <sub>2</sub>	S <sub>3</sub>	S <sub>4</sub>	S <sub>5</sub>	S <sub>6</sub>	S <sub>7</sub>	S <sub>8</sub>
0	0	1	0	1	0	0	0	0
V <sub>dc</sub> /5	0	1	0	0	0	0	0	1
2V <sub>dc</sub> /5	0	1	0	0	0	0	1	0
3V <sub>dc</sub> /5	0	1	0	0	0	1	0	0
4V <sub>dc</sub> /5	0	1	0	0	1	0	0	0
V <sub>dc</sub>	1	1	0	0	0	0	0	0
-V <sub>dc</sub> /5	0	0	1	0	1	0	0	0
-2V <sub>dc</sub> /5	0	0	1	0	0	1	0	0
-3V <sub>dc</sub> /5	0	0	1	0	0	0	1	0
-4V <sub>dc</sub> /5	0	0	1	0	0	0	0	1
-V <sub>dc</sub>	0	0	1	1	0	0	0	0

**3. A PROPOSED 3-PHASE MLI WITH REDUCED NUMBER OF SWITCHES FED TO INDUCTION MOTOR CONFIGURATION-2**

The proposed configuration-2 for an eleven level MLI with a common DC link is shown in Figure 2. In this topology, the total switch count is 24 for an eleven level MLI fed 3-Phase induction motor, in the case of a conventional three phase Eleven level cascaded H-bridge inverter (CHB) fed to induction motor the switch count would be 60. So the required number of switches and gate driver circuits for designing the circuit are reduced in this topology there by reducing the complexity of the overall circuit. It reduces the installation area and consequently the cost of the whole setup. In configuration-2 a single common DC link voltage source is used for all the three phases.

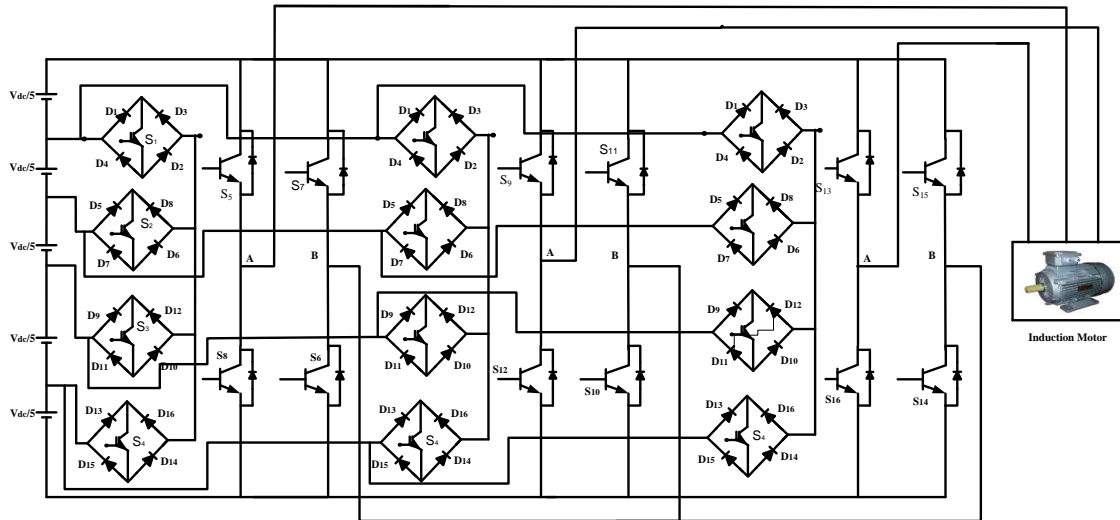

Figure 2. Block diagram for a novel Integrated Three phase eleven level MLI with reduced count of switches for Induction Motor Drive.

**4. A NOVEL INTEGRATED THREE PHASE ELEVEN LEVEL MLI WITH INDUCTION MOTOR DRIVE**

The simulation modeling of a novel eleven level MLI fed induction motor drive is shown in Figure 3. The simulation results for line voltages are shown in Figure 4. From this the peak to peak line voltage of 11 kV is measured.

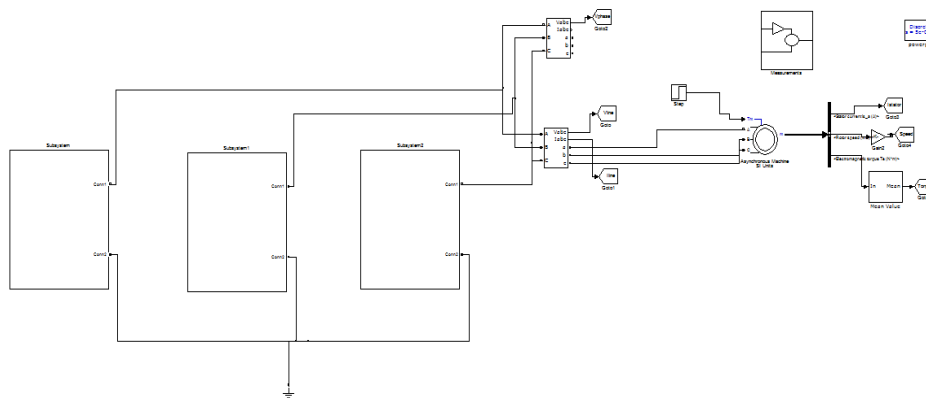

Figure 3. MATLab/Simulink model of a novel eleven level MLI fed Induction Motor

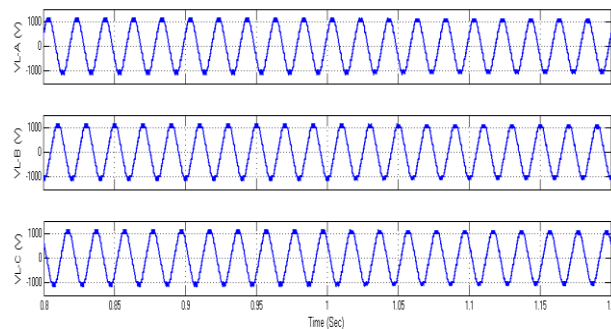

Figure 4. Simulation results for Line voltage of MLI

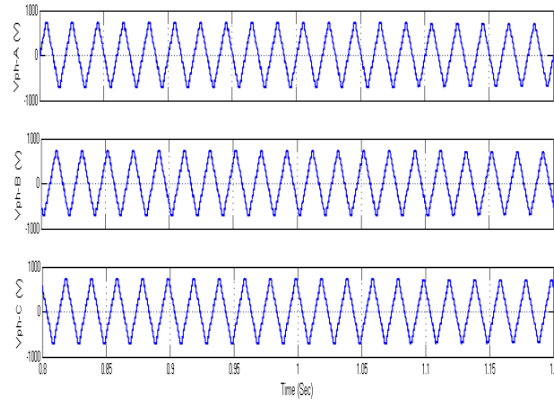

Figure 5. Simulation results for Phase voltage of MLI

The phase voltages of MLI are shown in above Figure 5. In this it is observed that the peak to peak voltage magnitude is 440 volts.

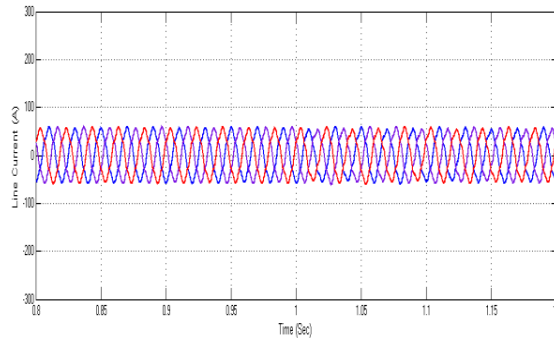

Figure 6. Simulation results for Line current of MLI

The simulation result for a line current of an eleven level MLI is shown in Figure 6. The magnitude of peak to peak current observed is 50A.

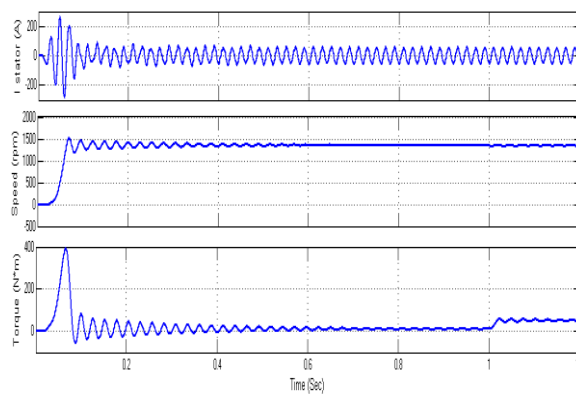

Figure 7. Simulation results for Induction motor stator current, speed and torque

The performance characteristics of induction motor are shown in Figure 7. In this Stator current, speed and torque of an induction motor are shown in above. From the characteristics curve it is observed that

the motor draws a current of 50A, and torque is 50 N-m with a speed of 1400 rpm. And it is also observed that the starting torque is very high and within a short time it reaches to 10 N-m.

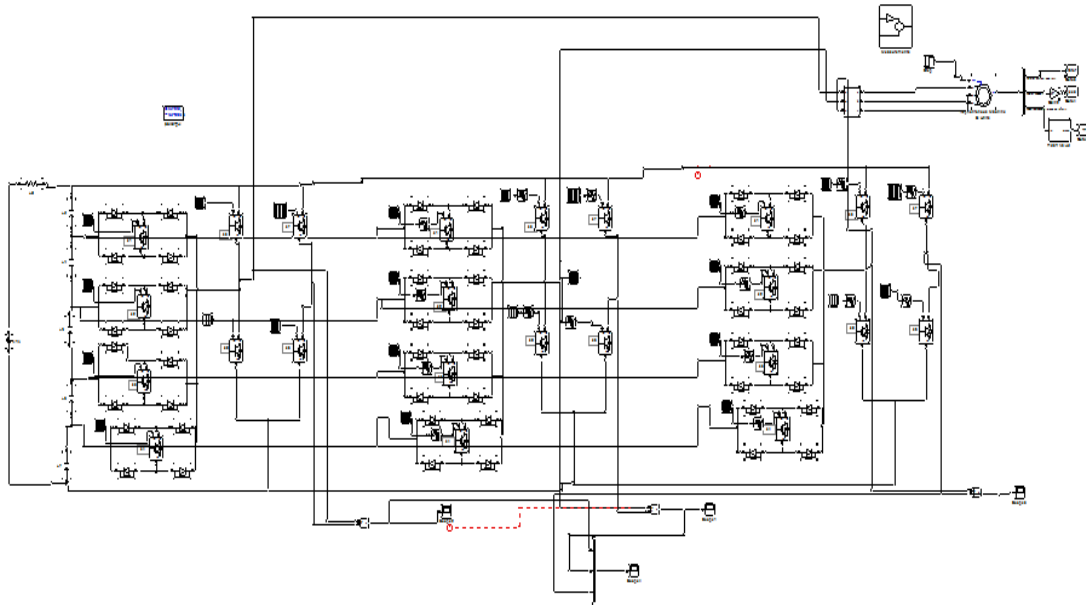

Figure 8. Simulation model of single DC Link Voltage source fed an eleven level MLI with an induction motor drive.

The simulation circuit for an eleven level MLI with a single DC voltage source is shown in Figure 8. In this the induction motor drive is connected to the inverter and the corresponding motor characteristics are obtained.

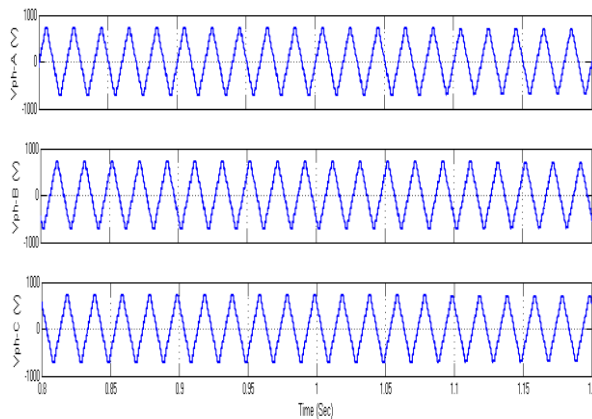

Figure 9. Simulation results for phase voltage

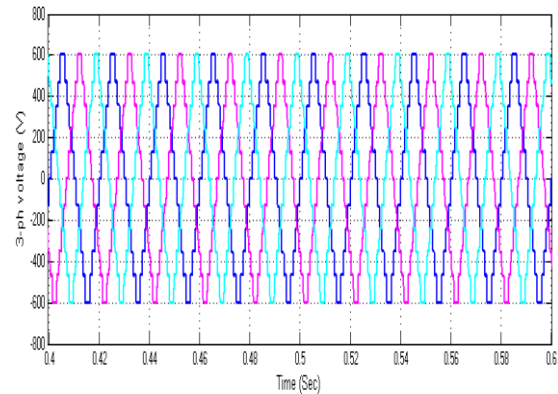

Figure 10. Simulation results for three phase voltage

The individual phase voltages and the 3-phase voltages are shown in above Figure 9 and Figure 10 respectively. Here each phase is displaced by a phase displacement of 120 degrees. The peak to peak magnitude of a three phase voltage is 600 volts.

The line current drawn by the induction motor is 50 amps and the wave form is shown in Figure 11.

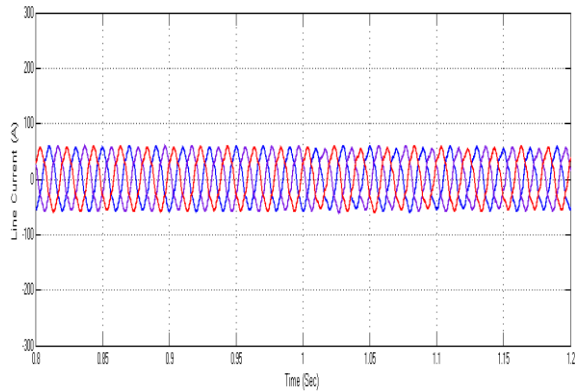

Figure 11. Simulation result of a line current of MLI

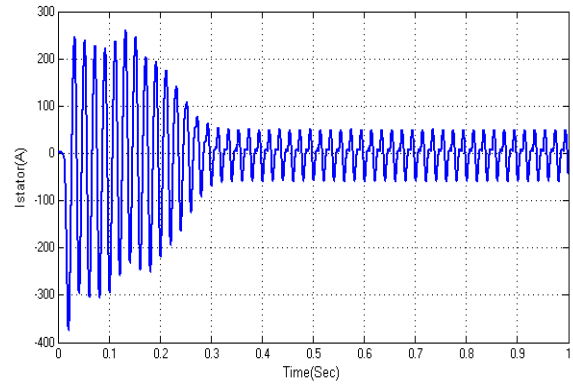

Figure 12. Simulation result of stator current drawn by the Induction Motor Drive

The Figure 12 represents the stator current drawn by the Induction motor drive which is connected to the inverter circuit. From the wave form it is observed that the stator current of the motor is approximately 50A.

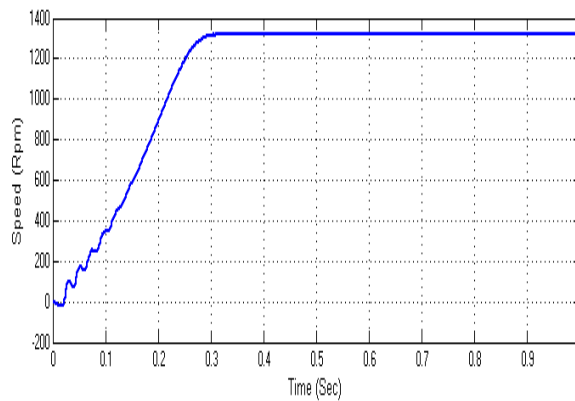

Figure 13. Speed wave form of an Induction motor

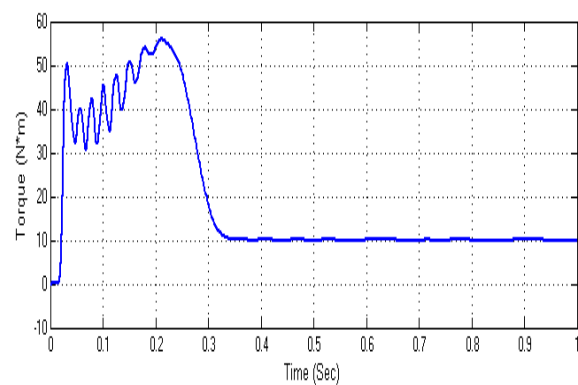

Figure 14. Simulation results for Induction motor stator current, speed and torque

The Figure 13 represents the Speed characteristics of the induction motor drive and the speed is observed as 1400rpm.

The torque characteristics for an Induction motor with the proposed inverter configuration are shown in Figure 14 and it is observed as 10N-m.

From all the above results it is observed that the configuration-2 gives similar results as in case of configuration-1 with less DC sources. The magnitudes of current, speed and torque of an induction drive are 50amps, 1400rpm and 10 N-m respectively in the case of configuration-1.

## 5. CONCLUSION

In conclusion, it is strongly confirmed that the proposed topology gives the multilevel output voltage with a less number of switch count. This paper presented a novel three phase hybrid H-bridge MLI is connected to an induction motor drive. Here the fundamental switching frequency control is used to decrease the switches and total harmonic distortion. The quality of the output waveform is observed by connecting it to induction motor. In the case of configuration 1, the three phases are supplied by a separate DC links and in configuration-2, only one common DC link is connected to get the same level of output voltage. In both the cases the performance characteristics current, speed and torque of an induction motor are presented and are same. Therefore, the configuration 2 is suggested with less number of switches as well as less number of DC

sources which reduces the installation area and cost. This topology can be easily implemented for industrial drives applications.

## REFERENCES

- [1] Arjyadhara Pradhan, "Design and Modeling of simplified Boost converter for Photovoltaic system", *IJECE*, Volume 8, No 1
- [2] Mohd Azman Rosli, Nor Zaihar Yahaya, Zuhairi Baharudin, "Multi-input DC-AC Inverter for Hybrid Renewable Energy Power System", *IJECE*, Volume 6i1.pp40-52
- [3] Mhamed Madark, A. Ba-Razzouk, E. Abdelmounim, M.El Malah, "A New Induction Motor Adaptive Robust Vector Control based on Back stepping", *IJECE*, Volume 7i4.pp1983-1993
- [4] J. Ebrahimi, E. Babaei, and G. B. Gharehpetian, "A new multilevel converter topology with reduced number of power electronic components," *IEEE Trans. Ind. Electron.*, vol. 59, no. 2, pp. 655–667, Feb. 2012.
- [5] S. Mekhilef et al., "Digital control of three phase three stage hybrid multilevel inverter," *IEEE Trans. Ind. Electron.*, vol. 9, no. 2, pp. 719–727, May 2013.
- [6] M.E.Ahmed, S.Mekhilef, "Design and implementation of a multilevel three-Phase inverter with less switches and low output voltage distortion," *Journal of Power Electronics*, vol.9, no.4, pp.593–603, Jul. 2009.
- [7] S. Mekhilef and M. N. Abdul Kadir, "Novel vector control method for three-stage hybrid cascaded multilevel inverter", *IEEE Transactions on Industrial Electronics*, DOI: 10.1109/TIE.2010.2049716 (in press), 2010
- [8] R.H. Baker, "Low-Voltage Converter Circuit," U.S. Patent Number 4,203,151, May 1980.
- [9] Bendaha Yesma Mazari Benyounes, "Conception of an hybrid control of induction motor with an adaptive luenberger speed controller using parameters machine estimation", *JEE*, Volume 3-2016
- [10] C.Bharatiraja R.Latha, "A new asymmetrical single phase 15 level reduced switch multilevel voltage source inverter", *JEE*, Volume 4-2015

## BIOGRAPHIES OF AUTHORS



**A. Ramesh** received his B. Tech in Electrical & Electronics Engineering and M.Tech in High Voltage Engineering from JNTU College of Engineering, Kakinada, Andhra Pradesh, India. He is pursuing Ph. D in Multilevel Inverter Technologies at Koneru Lakshmaiah Education Foundation India. Currently he is working as Associate Professor in the Department of Electrical and Electronics Engineering, Aditya college of Engineering, Surampalem, A.P. India. He is a life member of the Indian Society for Technical Education.



**O. Chandra Sekhar** received his B. Tech degree in Electrical & Electronics Engineering from JNTUH, India in 2005 and M. Tech with power Electronics and Electrical Drives from Vignan's Engineering College, Vadlamudi, India in 2008. He obtained his Ph. D. from J.N.T.U College of Engineering, Hyderabad in 2014. He has been with Koneru Lakshmaiah Education Foundation, India as Professor. His Research interests are Power Electronics, Industrial Drives.



**M. Siva Kumar** was born in Amalapuram, India in 1971. He received bachelor's degree in Electrical & Electronics Engineering from JNTU College of Engineering, Kakinada and M.E and PhD degree in control systems from Andhra University College of Engineering, Visakhapatnam, in 2002 and 2010 respectively. His research interests include model order reduction, interval system analysis, design of PI/PID controllers for Interval systems, sliding mode control, Power system protection and control. Presently he is working as Professor & H.O.D of Electrical Engineering department, Gudlavalleru Engineering College, Gudlavalleru, A.P, India