

Predictive Power Control of Grid and Rotor Side converters in Doubly Fed Induction Generators Based Wind Turbine

Abdelmalek Boulahia*, Mehdi Adel*, Benalla Hocine*

* Department of Electrical Engineering, Montoury Constantine University, ALGERIA

Article Info

Article history:

Received Feb 11, 2013

Revised Apr 10, 2013

Accepted May 14, 2013

Keyword:

Predictive direct power control

PWM converter

Double fed induction generator

Wind turbine

ABSTRACT

This paper presents a new control scheme for grid and rotor side for doubly fed induction generator (DFIG) using model based predictive control. The control strategy minimizes quality functions, which represent the desired behavior of the converter. The technique developed uses predictive direct power control to control the rotor and grid side converter. The main advantages of this method are no need of linear controllers, coordinates transformations or modulators for converter and inverter. Simulation results demonstrate robust, precise, and fast dynamic behavior of system.

Copyright © 2013 Institute of Advanced Engineering and Science.
All rights reserved.

Corresponding Author:

Abdelmalek Boulahia,
Departement of Electrical Engineering,
Montoury Constantine University, ALGERIA
Email: boulahiamalek@yahoo.fr

1. INTRODUCTION

Doubly-fed induction generator (DFIG) wind turbines with converters rated at about 25–30% of the generator rating are becoming increasingly popular. DFIG-based wind turbines offer variable speed operation, four-quadrant active and reactive power capabilities, lower converter cost, and reduced power loss compared to wind turbines using fixed speed induction generators or fully-fed synchronous generators with full-sized converters.

One of the most conventional control methods for DFIG is vector control in which rotor currents are decoupled into stator active power (or torque) and reactive power (or flux) and these two currents are controlled in the reference frame fixed to stator flux (or voltage) [3]-[6]. In this method accurate value of machine parameters such as resistances and inductances are required and nonlinear operation of converter for tuning current controllers is not considered. So performance of vector control method is affected by changing machine parameters and operation condition. Direct torque control (DTC) of induction machine drives was developed in the mid 1980s. DTC is based on decoupled torque and flux control which have very fast and precise dynamic without using inner control loop. the control of DFIG in which the rotor flux is estimated and an optimal switching table is used based on rotor flux position, based on DTC strategy, direct power control (DPC) is developed to control the DFIG. But the problem with this method is that variation of Grid side converter (GSC) is used to maintain DC link voltage at desired reference level for all operation conditions of DFIG. In [3], [5] conventional voltage-oriented control (VOC) is used to control GSC. In this method two decoupled current control loops are used to control DC voltage and reactive power which result in complex algorithm and dependency of system response on system parameters and operation condition. Because of dependence of rotor active power on generator speed, it has fast dynamic and in order to have constant DC voltage the GSC must transmit the active power between rotor and grid with a fast response.

The model predictive control is similar to (DTC for rotor side and DPC for grid side) only in that they both select one and only one voltage vector, but the basic principle in selecting voltage vector is very different. The DTC (DPC) uses a heuristic switching table to obtain the vector, which is determined when the difference between preferences and estimations occurs. On the contrary, the model predictive, predicts the evolutions of torque (active power) and flux (reactive power) over the next several periods for each possible voltage vector, and then selects the one minimizing the errors between the references and estimations. As a result, better performance can be anticipated for Predictive control. It can be said that the voltage vector obtained from Predictive Control is more accurate and effective in controlling the torque (active power) and rotor flux (reactive power) than its counterpart obtained from DTC (DPC). The key technology of Predictive Control lies in the definition of cost function, which is usually related to the control objectives.

2. GRID SIDE PREDICTIVE POWER CONTROL

The whole diagram of the predictive direct power control of grid side is illustrated in Figure 1.

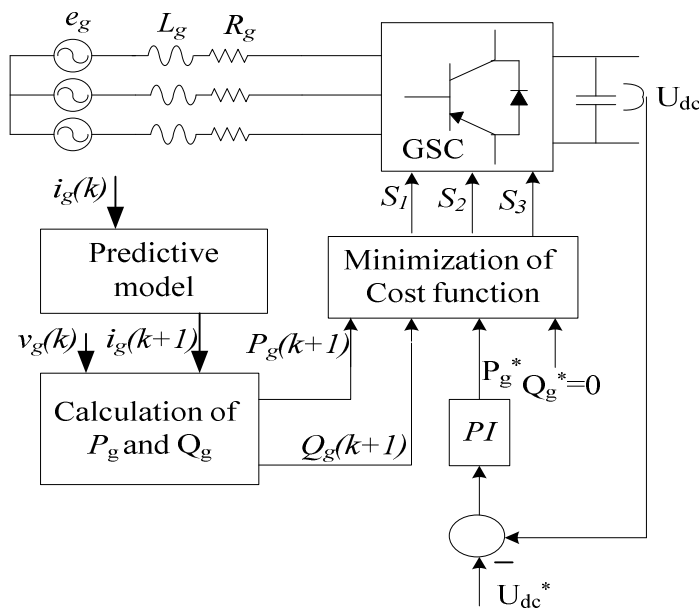

Figure 1. Schematic of the original predictive DPC control strategy of grid side PWM converter.

The input filter model can be described by the following continuous-time equations:

$$L_g \frac{di_g}{dt} = e_g - v_i - R_g \tag{1}$$

Where R_g and L_g are the filter resistance and inductance, respectively, and e_g is the grid voltage. v_i converter voltage applying a sampling periods, the derivative form di/dt can be approximated by:

$$\frac{di_g}{dt} = \frac{i_g(k) - i_g(k-1)}{T_s} \tag{2}$$

Replacing (2) in (1) and shifting the discrete time one step forward, the relation between the discrete-time variables can be described as:

$$i_g(k + 1) = \frac{T_s}{R_g T_s + L_g} \left[\frac{L_g}{T_s} i_g(k) + e_g(k + 1) - v_i(k + 1) \right] \tag{3}$$

Equation (3) is used to obtain predictions for the future value of the input current $i_g(k + 1)$ for each voltage vector $v(k + 1)$ generated by valid switching states.

Considering the input voltage and current vectors in orthogonal coordinates, the predicted instantaneous input active and reactive power can be expressed by equations:

$$P_g(k + 1) = Re\{e_g(k + 1)\bar{i}_g(k + 1)\} \tag{4}$$

$$Q_g(k + 1) = Im\{e_g(k + 1)\bar{i}_g(k + 1)\} \tag{5}$$

Where $i_g(k+1)$ is the predicted input current vector, for a given voltage vector generated by the rectifier v_i . For a small sampling time, with respect to the grid fundamental frequency, it can be assumed that:

$$v_g(k + 1) \approx v_g(k) \tag{6}$$

The cost function g_g summarizes the desired behavior of the rectifier: minimize the reactive power Q_g and control the active power P_g to be equal to reference value P_g^* .

$$g_g = (|P_g^* - P_g(k + 1)| + |Q_g^* - Q_g(k + 1)|) \tag{7}$$

$$v_i \in \{V_0, V_1, V_2, V_3, V_4, V_5, V_6, V_7\}$$

Where Q_g^* and P_g^* are the required active and reactive input power, and Q_g and P_g are the predicted active and reactive input power, which depend on the conduction state. As sinusoidal input currents, in phase with the supply line voltages, are required, the reactive input power reference must be zero. On the other hand, the DC link voltage is regulated by controlling the input power P_g^* required by the load.

3. ROTOR SIDE PREDICTIVE POWER CONTROL

The whole diagram of the predictive control in this paper is illustrated in Figure 2.

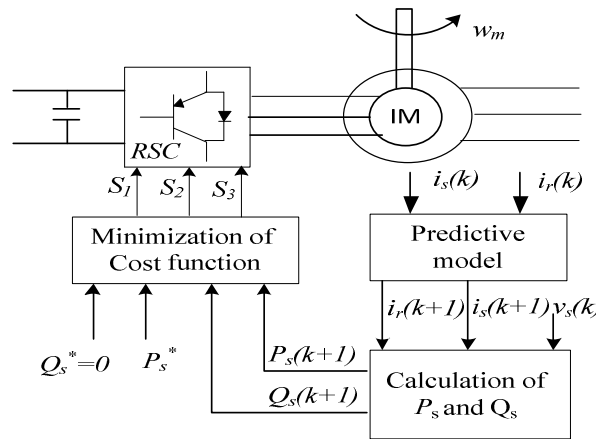

Figure 2. Schematic of the original predictive DPC control strategy of rotor side PWM converter.

Dynamic equations that describe the behavior of an induction machine are widely studied [3], [5], [8]. the stator and rotor voltage equations in fixed rotor coordinates can be presented as:

$$v_s = R_s i_s + \frac{d\psi_s}{dt} + j\omega_s \psi_s \tag{8}$$

$$v_r = R_r i_r + \frac{d\psi_r}{dt} \tag{9}$$

Where R_s and R_r are the stator and rotor resistances, ψ_s and ψ_r are the stator and rotor fluxes and ω_s is the stator angular frequency. All variables are considered in rotor reference frame. The stator and rotor fluxes are related with the stator and rotor currents by:

$$\psi_s = L_s i_s + L_m i_r \quad (10)$$

$$\psi_r = L_r i_r + L_m i_s \quad (11)$$

Where v_s , v_r , i_s , i_r , ψ_s , and ψ_r are the stator voltage, rotor voltage, stator current, rotor current, stator flux linkage and rotor flux linkage, respectively; R_s , R_r , L_s , L_r , and L_m are the stator resistance, rotor resistance, stator inductance, rotor inductance and mutual inductance, respectively.

The stator active and reactive power can be calculated from the stator voltage and currents as:

$$P_s = \frac{3}{2} \text{Re}\{\bar{i}_s^* \bar{v}_s\} \quad (12)$$

$$Q_s = \frac{3}{2} \text{Im}\{\bar{i}_s^* \bar{v}_s\} \quad (13)$$

Substituting (8), (9) and (10), (11) into (12) and (13), the active and reactive power can also be expressed in terms of stator flux and rotor flux as:

$$P_s = \frac{3}{2} \omega_s \lambda L_m \text{Im}(\bar{\psi}_r^* \bar{\psi}_s) \quad (14)$$

$$Q_s = \frac{3}{2} \omega_s \lambda \left[L_r |\psi_s'|^2 - L_m \text{Re}(\bar{\psi}_r^* \bar{\psi}_s) \right] \quad (15)$$

Where ω_l is the synchronous speed, $\lambda = 1/(L_s L_r - L_m^2)$

The presented continuous-time model of the induction machine describes the behavior of the machine's variables. Discrete-time equations are derived from this model, in order to obtain active and reactive power predictions for the next sampling interval, where k represent the present sampling instant. Discrete-time transformation is computed simply by sampling signals and considering a first-order approximation for first derivative forms. The discrete-time equation for stator and rotor flux prediction, obtained from the presented model, is:

$$\psi_s(k+1) = \psi_s(k) + T_s [v_s(k) + R_s i_s(k) - j \omega_r \psi_s(k)] \quad (16)$$

$$\psi_r(k+1) = \psi_r(k) + T_s [v_r(k) + R_r i_r(k)] \quad (17)$$

Where, T_s is the sampling time.

Using equations (16) and (17) into (14) and (15), the discrete-time prediction of the active and reactive power can be computed as:

$$P_s(k+1) = \frac{3}{2} \omega_s \lambda L_m \text{Im}(\bar{\psi}_r^*(k+1) \bar{\psi}_s(k+1)) \quad (18)$$

$$Q_s(k+1) = \frac{3}{2} \omega_s \lambda \left[L_r |\psi_s'(k+1)|^2 - L_m \text{Re}(\bar{\psi}_r^*(k+1) \bar{\psi}_s(k+1)) \right] \quad (19)$$

Equation (18) and (19) are used to obtain predictions of active and reactive power for each of the 8 valid switching combinations. Each switching state produce a possible $v(k+1)$ to be applied to the rotor in the next sampling instant. That voltage will depend on the switching state to be selected and on the input voltages, as presented in (11) and (16). Every possible switching state will produce a given value for $v(k+1)$ that will change the machine's predictions according to equation (18)-(19).

The key technology of predictive direct power control lies in the definition of cost function, which is usually related to the control objectives. For DFIG used in wind energy applications, the torque (corresponding to active power) and rotor flux (corresponding to reactive power) are of concern. The cost function will be defined in such a way that active and reactive power at the end of the control period is as close as possible to the commanding value. Specifically, the cost function is defined as:

$$g_s = (|P_s^* - P_s(k+1)| + |Q_s^* - Q_s(k+1)|) \quad (20)$$

$$v_r \in \{V_0, V_1, V_2, V_3, V_4, V_5, V_6, V_7\}$$

It should be noted that when a null vector is selected, the specific state (V0orV7) will be determined on the principle of minimal switching commutations, which is related to the switching states of the old voltage vector.

4. SIMULATION RESULTS

To validate the proposed PDPC strategy, simulations using Matlab/Simulink are carried out. The system and machine parameters are listed in Table. 1.

Table 1. Parameters of simulation of DFIG

Generator	Rated Power	2MW
	Stator voltage	690 V
	Rs	2.6mΩ
	Rr	2.9mΩ
	Lls	2.58mH
	Llr	2.58mH
	Lm	2.5mH
	Pole paires	2
Converter	DC link voltage	1200V
	DC linkcapacitor	16mF
	Gridside inductance	0.4mH

The rotor speed is operating at 100red/s. The active power steps from zero to 1 MW (motoring) at t=0.5 s and then steps from 1MW to -1 MW at t=0.55 s (generation). The reactive power is kept constant at zero, as shown in Figure 5.

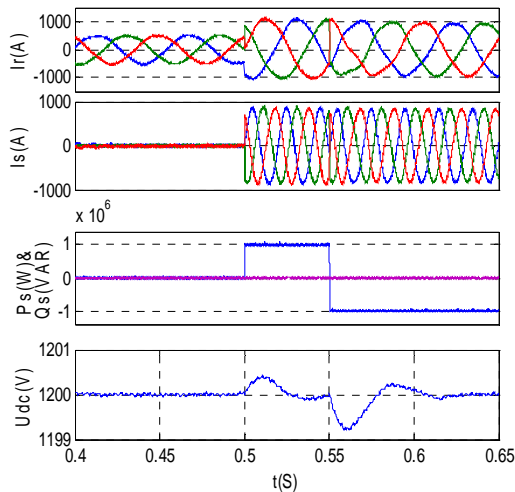

Figure 3. Responses rotor and stator current, active and reactive power, DC link voltage(wm= 100rad/s)

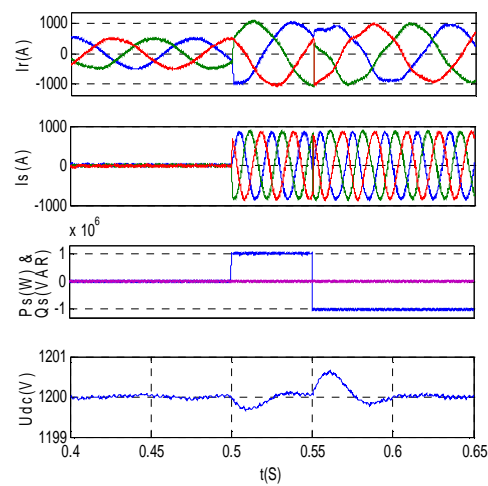

Figure 4. Responses rotor and stator current, active and reactive power, DC link voltage (wm= 200rad/s)

The harmonic spectra of stator and rotor currents under the steady state condition of 1 MW and subsynchronous speed are shown in Figure 6 and 7. The THD is calculated up to 5000 Hz harmonics.

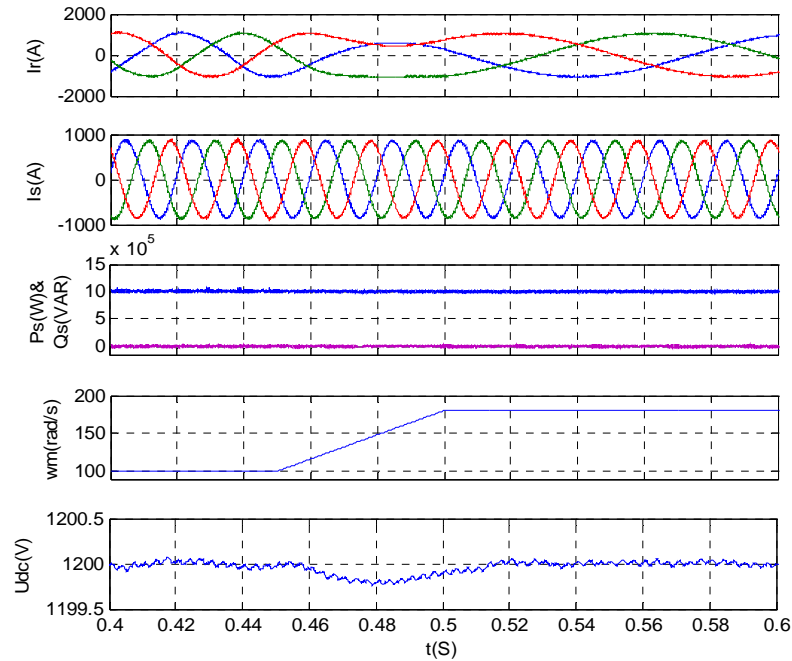

Figure 5. Responses rotor and stator current, active and reactive power, DC link voltage with rotor speed varying from 100 rad/s to 180 rad/s

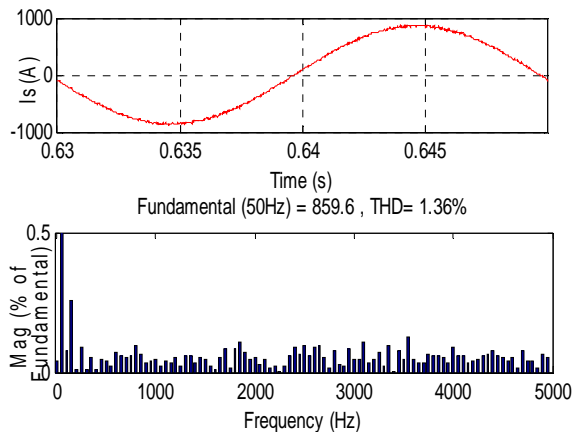

Figure 6. Harmonic spectrum of stator current

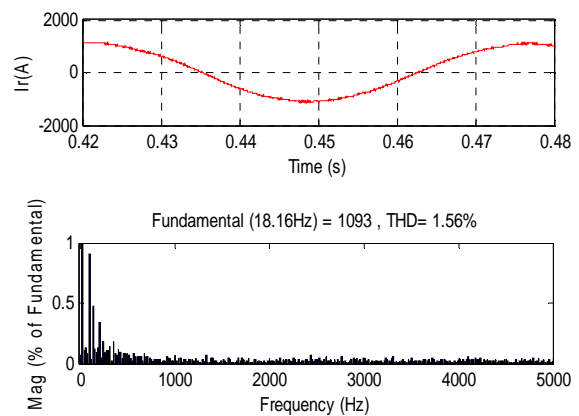

Figure 7. Harmonic spectrum of rotor current

5. CONCLUSION

Based on simulation results, it can be concluded that applied Predictive DPC strategy to control the DFIG has fast, precise and quicker response and better steady state performance. In addition stator and rotor currents have a low THD. In order to control DC link voltage, Predictive DPC strategy is used which has fast and robust performance and maintain the DC voltage at desired reference level, in all operation conditions. As a consequence, predictive control is a very promising alternative for the future of power electronics.

REFERENCES

- [1] T Lu, Z Zhao, Y Zhang, L Yuan. A novel Direct Power Control strategy for Three-level PWM Rectifier based on fixed Synthesizing Vectors. *International conference on Electrical machines and systems, Wuhan*. 2008: 1143-1147.
- [2] W Chen, Y Zou, L Xu. *Direct Power Control For Neutral-Point-Clamped Three-Level PWM Rectifier*. IEEE international conference on industrial technology, Chengdu. 2008: 1-6.

- [3] G Abad, Miguel Angel Rodriguez, J Poza. Predictive Direct Power Control of the Doubly Fed Induction Machine with Reduced Power Ripple at Low Constant Switching Frequency. *IEEE International Symposium on Industrial Electronics, ISIE*. 2007; 1119-1124.
- [4] R Pena, JC Clare, GM Asher. *Double fed Induction Generator using Back-to-Back PWM Converter and its Application to Variable-speed Wind Energy Generation*. Proc. IEE Electr. Power Appl. 1996; 143(3): 231–241.
- [5] C Chu, C Hung, Y Lin, Z Guey. *Universal field-oriented Rotor-side Controllers for Doubly-fed Induction Generators*. International Conference on Power Electronics and Drive Systems. 2009; 342-347.
- [6] D ZHI, L Xu, W Williams. Improved Direct Power Control of Grid connected DC/DC Converters. *IEEE Trans. on Power Electronics*. 2009; 24(5): 1280-1292.
- [7] M Malinowski, M Kazmierkowski, A Trzynadlowski. A Comparative Study of Control Techniques for PWM Rectifiers in AC Adjustable Speed Drives. *IEEE Trans. on Power Electronics*. 2003; 18(6).
- [8] M Kazemi, A Yazdankhah, H Kojabadi. Direct Power Control of DFIG based on discrete Space Vector Modulation. *Elsevier, Renewable Energy*. 2010; 35(5): 1033-1042.
- [9] H Ko, G Yoon, N Kyung, W Hong. Modeling and Control of DFIG-based Variable-Speed Wind-turbine. *Elsevier, Electric Power Systems Research*. 2008; 78(11): 1841-1849.