

RFID Based Attendance Management System

Shashank Shukla, Shailee Shah, Pooja Save

Department of Information Technology, Thakur College of Engineering & Technology (TCET)
Kandivali-400101, Mumbai University, India

Article Info

Article history:

Received Jul 19, 2013

Revised Oct 8, 2013

Accepted Oct 30, 2013

Keyword:

RFID

Automated

Tracking

Attendance

ABSTRACT

Radio-frequency identification (RFID) is a technology that uses radio waves to transfer data from an electronic tag, called RFID tag or label, attached to an object, through a reader for the purpose of identifying and tracking the object. RFID technology is a matured technology that has been widely deployed by various organizations as a part of their automation systems. In this project, an RFID based system has been built in order to produce an attendance management system. An automated attendance management software will not only make the entire process simple, but will also provide a well-structured and analyzed report of the pattern of student attendance and time management, which can further help in allocating and using the human resources in an organization to the maximum possible benefit. This system consists of two main parts which include: the hardware and the software. The hardware consists of a motor unit and RFID reader. The RFID reader, which is a low-frequency reader (125 kHz), is connected to the host computer via a serial to USB converter cable. The Time-Attendance System GUI is developed using Visual Basic.Net. The Attendance Management System provides the functionalities of the overall system such as displaying live ID tags transactions, registering ID, deleting ID, recording attendance and other minor functions. This interface was installed in the host computer.

*Copyright © 2013 Institute of Advanced Engineering and Science.
All rights reserved.*

Corresponding Author:

Shashank Shukla

Departement of Information Technology,

Thakur College of Engineering & Technology,

Shyamnarayan Thakur Marg, Thakur Village, Kandivali (E), Mumbai-400101

Email: kshashank343@gmail.com

1. INTRODUCTION

The existing conventional attendance system requires students to manually sign the attendance sheet every time they attend a class. As common as it seems, such system lacks automation, where a number of problems may arise. This includes the time unnecessarily consumed by the students to find and sign their name on the attendance sheet; some students may mistakenly or purposely sign another student's name. Also the attendance sheet may get misplaced [1].

Having a system that can automatically capture student's attendance by flashing their student card at the RFID reader can really save all the mentioned troubles. This is the main motive of our system and in addition having an online system accessible anywhere and anytime can greatly help the lecturers to keep track of their students' attendance. Looking at a bigger picture, deploying the system throughout the academic faculty will benefit the academic management as students' attendance to classes is one of the key factor in improving the quality of teaching and monitoring their students' performance. Besides, this system provides valuable online facilities for easy record maintenance offered not only to lecturers but also to related academic management staffs especially for the purpose of students' progress monitoring [2-3].

2. LITERATURE SURVEY

In the process of system development, literature reviews conducted to understand the theory, methods and technologies associated with systems that have been developed. Background research on the organization and comparative studies of existing systems is also done to understand the system requirements before the system was developed [4]. Student Attendance Using RFID System is an automatic record of student attendance developed especially for universities. Figure 1 shows overall block diagram of the system [5].

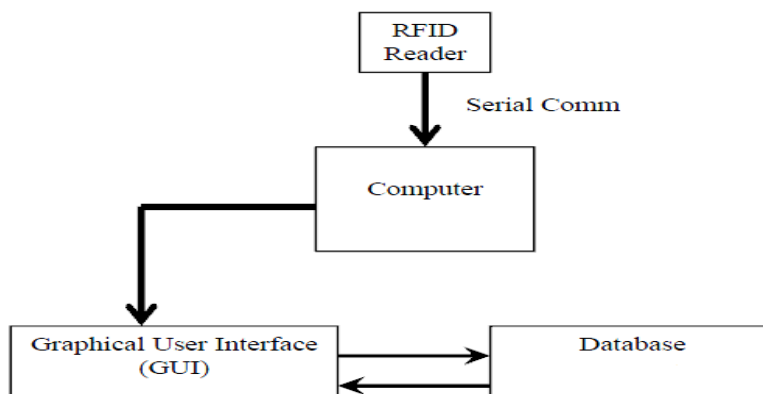

Figure 1 Block Diagram

It's generally said that the roots of radio frequency identification technology can be traced back to World War II. The Germans, Japanese, Americans and British were all using radar which had been discovered in 1935 by Scottish physicist Sir Robert Alexander Watson-Watt to warn of approaching planes while they were still miles away. The problem was there was no way to identify which planes belonged to the enemy and which were a country's own pilots returning from a mission. Radio Frequency Identification (RFID) research and discovery began in earnest in the 1970s. RFID is commonly used to transmit and receive information without wires. RFID readers and tags communicate through a distance using radio waves. There are a lot of advantages in RFID system, included their price, size, memory capacity and their capability. Advances in radar and RF communications systems continued through the 1950s and 1960s. Electronic article surveillance tags, which are still used in packaging today, have a 1-bit tag. The bit is either on or off. If someone pays for the item, the bit is turned off, and a person can leave the store. But if the person doesn't pay and tries to walk out of the store, readers at the door detect the tag and sound an alarm [5].

The First RFID Patents Mario W. Cardullo claims to have received the first U.S. patent for an active RFID tag with rewritable memory on January 23, 1973 [5]. Later, companies developed a low-frequency (125 kHz) system, featuring smaller transponders. A transponder encapsulated in glass could be injected under the cows' skin. This system is still used in cows around the world today. Low frequency transponders were also put in cards and used to control the access to buildings [5].

Today, 13.56 MHz RFID systems are used for access control, payment systems (Mobile Speedpass) and contactless smart cards. They're also used as an anti-theft device in cars. A reader in the steering column reads the passive RFID tag in the plastic housing around the key. If it doesn't get the ID number it is programmed to look for, the car won't start [5].

In the early 1990s, IBM engineers developed and patented an ultra-high frequency (UHF) RFID system. UHF offered longer read range (up to 20 feet under good conditions) and faster data transfer. IBM did some early pilots with Wal-Mart, but never commercialized this technology. When it ran into financial trouble in the mid-1990s, IBM sold its patents to Intermec, a bar code systems provider. Intermec RFID systems have been installed in numerous different applications, from warehouse tracking to farming. But the technology was expensive at the time due to the low volume of sales and the lack of open, international standards [5].

3. DESIGN, IMPLEMENTATION & INSTALLATION

Since the system is based on RFID, we do have some hardware component in the application. To keep the project simple and more software based, we are not designing any hardware architecture to the software system. We are going for basic hardware used as an interfacing device to read the data from the card and store it on application's database.

The Figures 2 and 3 will give a clearer view of a basic RFID Scanner & Card:



Figure 2. RFID Scanner



Figure 3. RFID Card

The task of the scanner is to read a ten digit unique RFID tag and feed it to any display device or visible fields on the screen. So each card has a film with a 10 digit unique RFID and the number is printed on the card itself for recognition purpose, as shown in Figure 4.

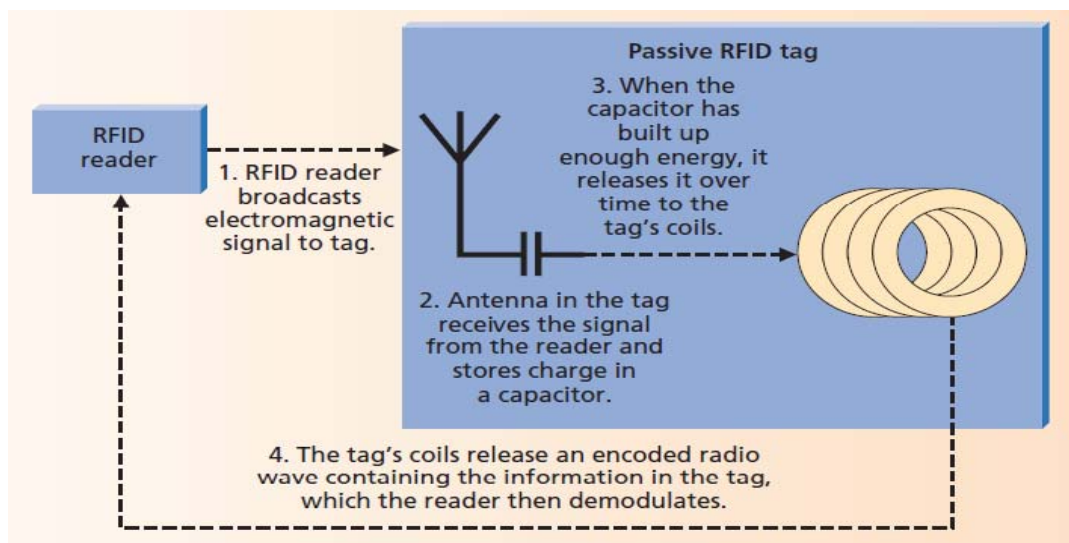

Figure 4. Simplified view of data transfer in low frequency passive RFID tags

3.1 Technical Specifications

System Requirements

Server:

Hardware

- Processor: Core 2 Duo Processor at 2.4 GHz or Higher
- Memory: 2 GB RAM or Higher
- HDD Storage: 80 GB or Greater

Software

- Microsoft Windows Server 2003 or 2008
- IIS (Internet Information Server)
- .NET Framework 2.0

Client:**Hardware**

- Processor: Pentium 4 Processor at 2.2 GHz or Higher
- Memory: Minimum 256 MB RAM
- HDD Storage: Minimum 10 GB Space

Software

- Web Browser (Mozilla Firefox, Internet Explorer 6.0 + , etc)

3.1. Block diagram & Network diagram of the system

The application is a web based application. So when we deploy it will have a server where all the web pages reside. All the data is stored in the database. The Client accesses this data using internet. The database is accessed via Server and the application works in the browser. To access the application in the browser, the user must have a valid RFID card (which is analogous to the one shown in the diagram above) and he needs to swipe it in front of the RFID Scanner. The block diagram of system is shown in Figure 5. RFID Scanner being plug and play can be replaced very easily without affecting the current application and there would be no data losses as there is no hardware storage involved in terms of the RFID Scanner. Moreover the RFID Scanner and the cards are cost effective.

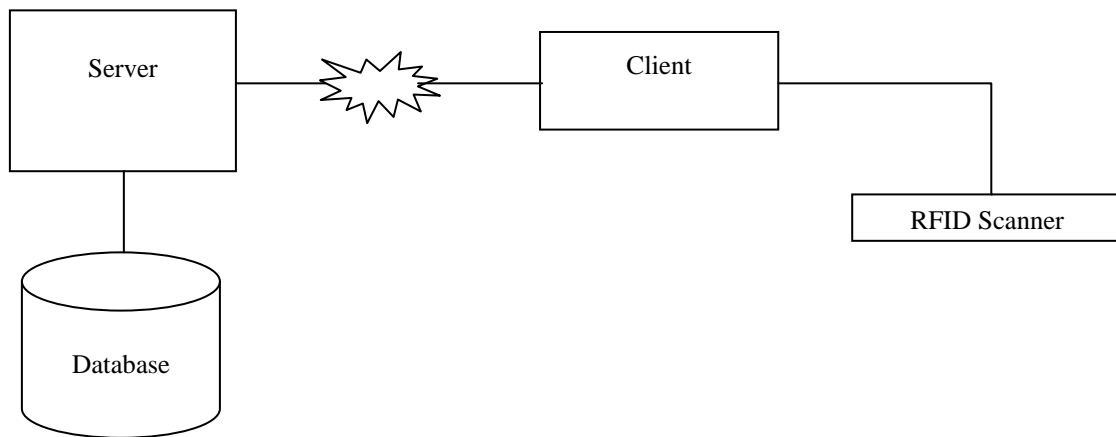

Figure 5. Block Diagram of System

So as far as the system implementation is concerned, we have to develop a web application in ASP.net with SQL Server as the backend. The RFID scanner acts as a tool to provide input in the form of attendance to the system. The advantage here is that the storage and intelligence is handled by the system itself; so even a basic scanner will work perfectly alright for the system.

The Block Diagram consists of 4 blocks. Each of them is explained below.

- **RFID Scanner**
RFID Scanner is a plug-play USB device that has only one task – If a valid task is swiped in front of the scanner, the RFID tag is read and its unique code is pasted on any text field on the active window of the screen.
- **Database**
Database of the application is MS SQL Server. So the database file is of type .mdf. Database would be MS SQL Server 2008 Management studio compatible. It'll be supplemented by Microsoft ASP.net Membership Provider.
- **Client**
On the client side the application is just loaded as a website. So on the client side, the only role is of the browser. The application runs in the browser with proper authentication and authorization.
- **Server**
Server is where all the web-pages reside. It consists of all the codes into two sets. One is the design side of the code and the other one is the actual coding. So page extensions are .aspx and .aspx.cs. The directory is divided accordingly for protection and security. Whenever, the client requests a data, the

server serves it. If at all, the data is required, then it'll retrieve from the database and send it as http stream to the browser. At the browser level, the product turns into html for rendering the data.

3.2. Network Diagram of the system

Flow of information from one block to another is shown in Figure 6.

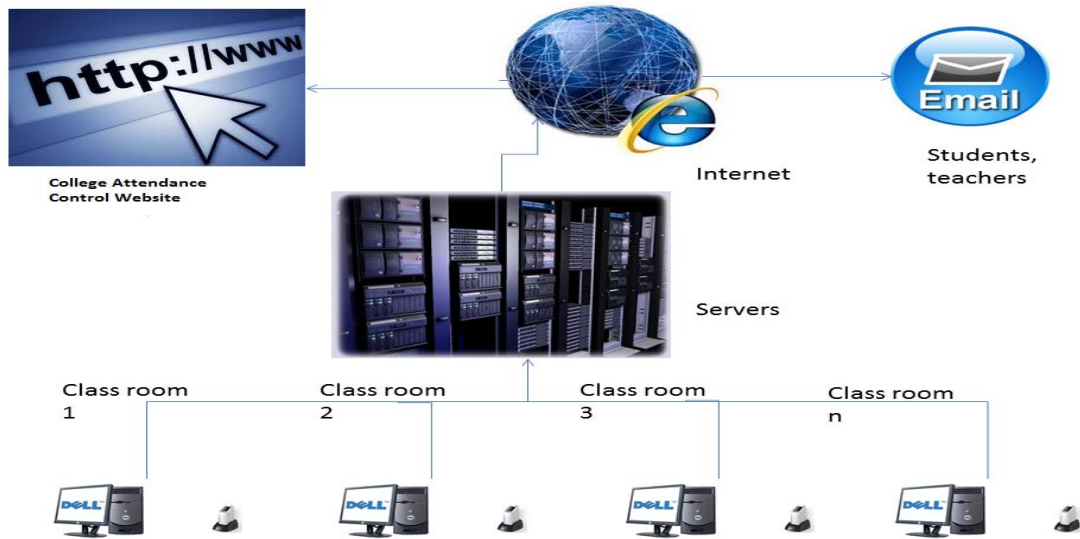
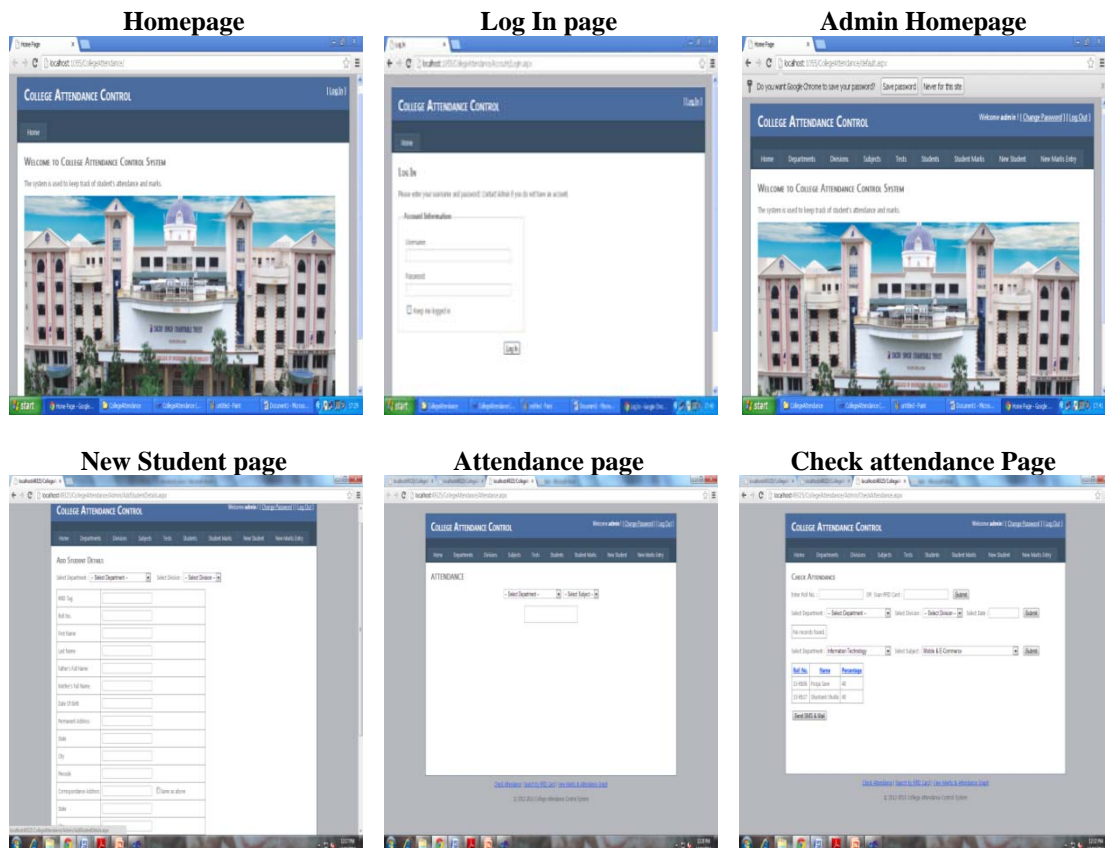

Figure 6. Network Diagram

4. RESULTS



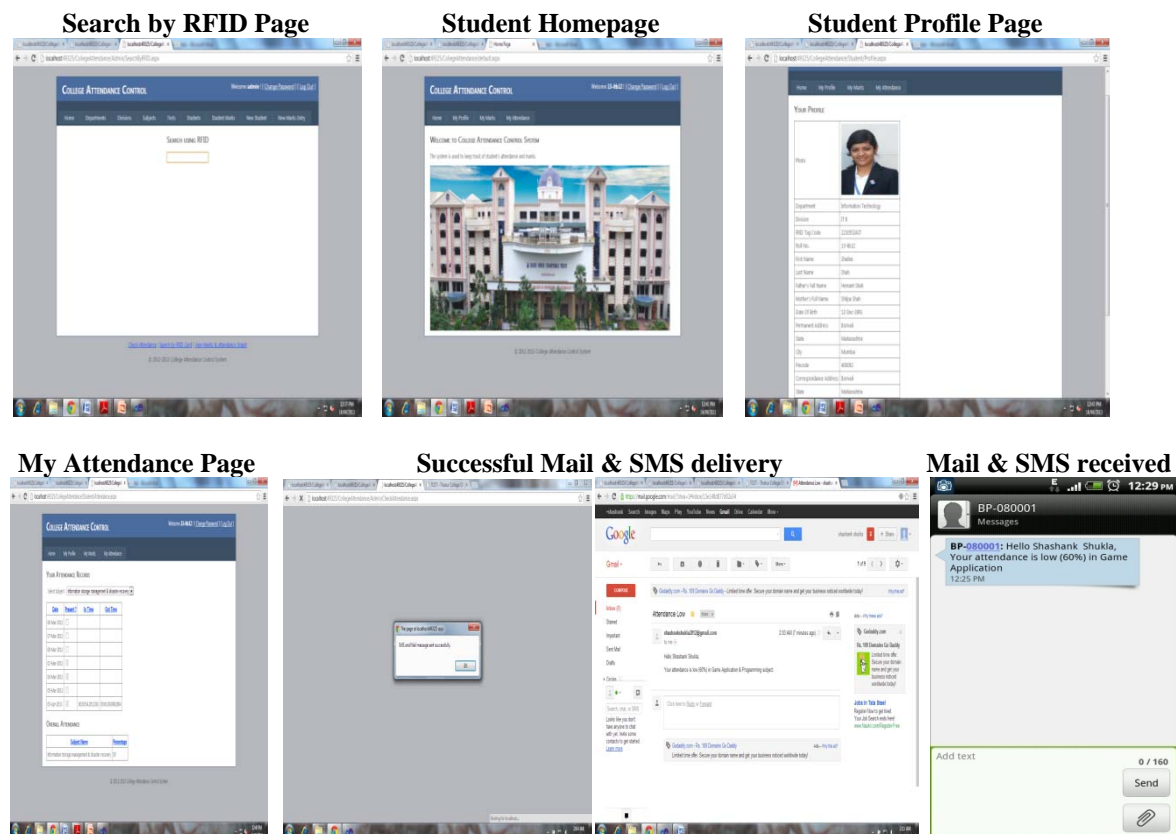

Figure 7. Some captures of the RFID Based Attendance Management System

5. CONCLUSION & SCOPE FOR FUTURE WORK

In conclusion, the objective to build an RFID based attendance system was successfully achieved. In terms of performance and efficiency, this project has provided a convenient method of attendance marking compared to the traditional method of attendance system. By using databases, the data is more organized. This system is also a user friendly system as data manipulation and retrieval can be done via the interface, making it a universal attendance system. Thus, it can be implemented in either an academic institution or in organizations.

However, some further improvements can be made on this RFID in order to increase its reliability and effectiveness. An indicator or an LCD screen can be incorporated into the system to indicate when any unregistered card is scanned. An IP camera can be integrated into this system to monitor the actions like buddy-punching wherein a person cheats by scanning for another person. Finally, this attendance system can be improved by adding a feature where the attendance system indicates when a student is late for work or classes as the case maybe.

ACKNOWLEDGEMENTS

With deep sense of gratitude we would like to thank all the people who have lit our path with their kind guidance. We are very grateful to these intellectuals who did their best to help during our paper. It is our proud privilege to express deep sense of gratitude to our B.E Project Guide Prof. Rajesh S. Bansode for his continuous guidance and support throughout our project and paper. It would never have been possible for us to complete this project successfully without his guidance and support. We remain indebted to our H.O.D, Dr. Kamal Shah, IT Department, Principal, Dr. B.K. Mishra for their comments and kind permission to complete this paper. We would also like to thank them for their timely suggestions and valuable guidance. And lastly we would like to thank our friends and the people who are directly or indirectly related to our paper.

REFERENCES

- [1] Ononiwu G, Chiagozie, Okorafor G. Nwaji. "Radio Frequency Identification (RFID) Based Attendance System With Automatic Door Unit". in *Academic Research International*, ISSN-L : 2223-9553. 2012; 2(2).
- [2] Zatin Singhal and Rajneesh Kumar Gujral. "Anytime Anywhere- Remote Monitoring of Attendance System based on RFID using GSM Network". in *International Journal of Computer Applications* (0975–8887). 2012; 39(3).
- [3] Herdawatie Abdul Kadir, Mohd Helmy Abd. Wahab, Zarina Tukiran, Ariffin Abdul Mutalib. "Tracking Student Movement using Active RFID". in *9th WSEAS International Conference*, ISSN : 1790-5117.
- [4] Elisabeth Ilie-Zudor, Zsolt Kemeny, Peter Egri, Laszlo Monostori. "The RFID Technology and its Current Applications" in *MITIP-2006*.
- [5] Mohd. Firdaus Bin Mahyidin. "Student Attendance Using RFID System". in *University Malaysia, Pahang*, May-2008.