

## Application of the ELECTRE III Method at the Moroccan Rural Electrification Program

Fatima Zahra El Mazouri<sup>1</sup>, Mohammed Chaouki Abounaima<sup>2</sup>, Khalid Zenkour<sup>3</sup>, Ahmed El Hilali Alaoui<sup>4</sup>

<sup>1,2,3</sup>Laboratory of Intelligent System & Applications, Faculty of Sciences and Technologies,  
University Sidi Mohamed Ben Abdellh, Morocco

<sup>4</sup>Laboratory of Modeling and Scientific Computing, University Sidi Mohamed Ben Abdellh, Faculty of Sciences and Technologies, Morocco

---

### Article Info

#### Article history:

Received Dec 6, 2017

Revised Jan 19, 2018

Accepted Sep 11, 2018

---

#### Keyword:

ELECTRE III method

Methods

Multi-criteria decision aid

Outranking approach

Rural electrification program

---

### ABSTRACT

As part of the integrated strategy of the Moroccan state aimed at the social and economic development of the Moroccan rural community, an electrification program has been in place since the 90s. This program, called PEGR, has for main objective the improvement of the electrification rate for the national rural world. Given the large number of villages to be electrified and the colossal budget that will induce, several criteria have been retained to objectively distinguish the villages with the highest priority for electrification. Given the nature of this problem to be solved, which is a multicriteria decision aid problem, we propose in this article to use the multicriteria aggregation method ELECTRE III to rank the villages from the highest priority to the lowest priority for the electrification.

Copyright © 2018 Institute of Advanced Engineering and Science.  
All rights reserved.

---

### Corresponding Author:

Fatima Zahra El Mazouri,

Laboratory of Intelligent System & Applications, Faculty of Sciences and Technologies,

Immouzer Road, Post Box: 2202, Fez, Morocco.

Email: fatimazahra.elmazouri@usmba.ac.ma.

---

## 1. INTRODUCTION

Convinced by the socio-economic problems, the very difficult living conditions of the rural population and to reduce the rate of rural exodus from villages to cities, the Moroccan state gave special importance to the development of rural Morocco. The studies [15], [1] have shown that any social and economic development to improve and promote rural life is possible only in the presence of an infrastructure environment that can encourage the creation of motor activities of evolution in the future. Among these infrastructures, we find the road networks, the availability of potable water and the electrification, in fact, these infrastructures constitute the infrastructures most directly linked to the start of the economic activities, to bring out the rural world of its insulation and to the improvement of socio-administrative services: education, health, courts and housing, which are the basic needs of the rural world. In order to meet the needs and expectations of the rural population, in the late 1980s and early 1990s, the Moroccan government set up a program known as the "Global Rural Electrification Program (GREP)". This program consists to link the entire Moroccan rural world to the rest of the national electricity grid until the year 2020.

Undoubtedly, it is a big project that has an inestimable importance for the development of the whole country and the rural world. After extensive studies [16] conducted by the government, more than 35.000 villages have been identified for the electrification program. Given the large number of localities to be electrified and therefore the huge budget that must be allocated to electrification, the government decided to proceed by slice, in fact, every year, a reduced list of villages will benefit from the GREP program. The problem that we are confronted in this context resides in the establishment of lists of villages which

constitute every slice of the program GREP. In this way, the first slice must contain only the highest priority villages, the second slice in turn contains the lower priority villages than the first and so forth.

To make an objective decision, which doesn't privilege any village to other villages, several criteria of choice were retained and adopted, of which we quote: the size of the population which represents the number of habitants, the cost of the electrification budget envisaged and the IRR criterion which represents the Internal Rentability Rate for the project. The annual selection of the highest priority villages by meeting all the criteria is clearly a multi-criteria decision problem. In this work we then intend to use multicriteria decision aid techniques, exactly we will opt for the multicriteria aggregation method ELECTRE III [8].

The choice of the ELECTRE III method is justified for several reasons, because it is a multicriteria aggregation procedure belonging to the outranking approach, it is a method that is not directly compensatory, the method ELECTRE III proceeds by pairwise comparisons between alternatives, moreover the results are not definitive for to take a decision, but they are analyzed following a step named robustness analysis, finally this method has been used successfully to solve several concrete problems of multicriteria decision. Thus, this method becomes the most appropriate for aggregating the different criteria to rank the best alternatives to the less good alternatives. In our problem, the alternatives represent candidate villages for electrification.

The present paper is structured as follows: after this introduction, we will present in the first section the general framework of the study. In the second section, we will give a quick overview of ELECTRE methods. In this same section, we will detail the method ELECTRE III adopted. In the third section, will be devoted to the application of the ELECTRE III method to the electrification program of the rural world. The results selected for application and discussion will be presented in the fourth section. We will end this work with a conclusion.

## **2. GENERAL FRAMEWORK OF THE STUDY ON THE DEVELOPMENT OF THE RURAL WORLD**

### **2.1. The Needs of the Rural World**

For a secure and guaranteed economic and social development, the Moroccan rural world needs mainly to be developed into three main infrastructures: roads, potable water and electricity. The first step of this study is then to identify all the localities (douars, sub-douars, villages or Kssour) spread over all the rural communes of the kingdom, which suffers from a notable lack in terms of the three infrastructures. This census is not a very easy affair, it took several years (since the end of the 80s and around the beginning of the 90s) to collect the necessary data on all the Moroccan villages. Three studies have been launched for to have a clear vision on the state of the rural world, they are.

The preparation study of the subsequent slices of the Global Rural Electrification Program (GREP). This study was initiated by the Energy Directorate of the former Ministry of Energy and Mines. The study of the national master plan for potable water procurement for rural populations (AEP). This study was conducted jointly by the former Ministry of Public Works, Vocational Training and Executive Training, the former Water Administration and the former Directorate of Research and Water Planning. The study on the program for the improvement and maintenance of unpaved country roads (RURAL RUNWAYS). This study was initiated by the Directorate of Roads and Road Traffic of the former Ministry of Public Works, Vocational Training and Executive Training.

At the end of these three studies, three databases were built: DB1 on roads, DB2 on electrification and a third database BD2 on potable water. Given the interrelationships between the three programs (GREP, AEP and RURALES RUNWAYS) and also considering the independence of the decision-making centers for these programs, it was necessary to adopt an integrated approach allowing integrated programming of basic infrastructures for the rural world. Such a programming approach requires the availability of a complete database, for decision-makers, that includes all the information available on the entire rural Moroccan world.

### **2.2. Study on the Development of the Database for the Rural World (BDMR)**

Finally, to have a global vision on the state and the needs of the rural world, a new study was launched with the mission of establishing an integrated database on the rural world. The three databases developed DB1, DB2 and DB3 have been regrouped and integrated in a single homogeneous and coherent database called BDMR: The Database of the Moroccan Rural World (BDMR). The BDMR database contains more than 370 attributes and more than 30,000 records. In total, more than 11 million information are available. To fully understand the diversity of information contained in the BDMR database, we summarize for each data base (DB1 of GREP, DB2 of AEP and DB3 of the RURAL RUNWAYS) the information's that are available there.

### 2.2.1. DB1: GREP Database

This database contains 30,426 localities, for each locality we have information about : the size of locality (population, number of households and rate of rural exodus), road access to the locality (main roads (MR) and secondary roads (SR)), nature of the terrain (mountain, valley, plain), the nature of construction (solid, mixed earth), the dispersion of the habitat, the dimensions of the entity (length and width), the existing administrative infrastructure (caidat, communal court, commune seat, etc.), social activities (courts, clinics, schools, etc.) and existing commercial activities (workshops, shops, oil mills, mills, souks, etc.). This database was used for the realization of the GREP program (Global Rural Electrification Program).

### 2.2.2. DB2: AEP Database

In addition to the information contained in the GREP database, the BDMR includes information from the AEP database (Potable Water Supply), this database contains the following information: Irrigated crops in the locality, the livestock in the locality, socio-economic infrastructures, schools, souks, workshops, administrative centers, health centers, mosques, connection to the electricity network, water needs, available water resources and existing hydraulic equipment.

### 2.2.3. DB3: Rural Runways Database

The DB3 database concerns the exhaustive inventory of the network of existing runways in the rural world, they are 30,426 runways have been identified. Each runway is identified by a locality-origin and a locality-extremity. The information collected for each runway are: the names of intermediate localities, length and technical data relating to the runway, the main access to the runway, indications of daily traffic, the mines served and circulation conditions.

## 2.3. Position of the Problem

As it was introduced before, considering the number of localities candidate for the electrification program, we count at the beginning of the program more than 35000 localities, and considering the colossal amount of the budget to be octroyed for this operation, we note that the launching for the entire project is impossible. To overcome this difficulty, the Moroccan state then decided to proceed by slices, in other words, each year a subset of localities to be electrified is selected.

The second problem facing the government is how to choose this subset of priority localities ?. In our opinion, the most convincing and rational answer is that which remains far from any subjectivity and from any political tendency and interest personal. This solution consists of selecting the most high-priority localities with respect to a set of pre-established criteria. The GREP program was approved by the government council in August 1995 and started in 1996. Its objective is to bring the rural electrification rate back to 90% as shown in Table 1.

Table 1. Summary Table of the Objectives Defined under the GREP

Year	Number of electrified rural households	Rural electrification rate
1995	400 000	21%
2000	900 000	45%
2005	1 500 000	75%
2010	2 000 000	99%

When it started in 1996, the Global Rural Electrification Program (GREP) was to spread over a period of 15 years, with the aim of increasing the rural electrification rate to 80% by 2010, by 1,000 villages, or 100,000 households a year, for an annual budget of 1 billion DH (Moroccan Dirhams).

## 3. THE ELECTRE METHODS

### 3.1. The ELECTRE Methods Family

The acronym ELECTRE (in French: ELimination Et Choix Traduisant la REalité) means "ELimination and Choice Translating the Reality". It's composed of a family of methods [8]. The family of ELECTRE methods was developed and applied for the first time by Bernard Roy in the 1960s [18]. Currently, it is considered the most robust method of multicriteria aggregation methods. One of the most important characteristics that distinguishes ELECTRE methods from many other multicriteria methods is that it's basically a non-compensatory process. This means that good evaluations on certain criteria cannot compensate for poor evaluations obtained in other criteria.

The family of ELECTRE methods are part of the outranking approach. This approach proceeds in two main steps, in the first step, we seek, by pairwise comparison, to construct a binary relation S between

*Application of the ELECTRE III method at the Moroccan Rural Electrification... (Fatima Zahra El Mazouri)*

the different alternatives. In the second step, the outranking relation  $S$  is exploited according to the problem to be solved. In the literature, there are other methods based on the outranking approach, of which we mention the PROMETHEE [5]. Over the years, several versions of the ELECTRE method have appeared, all these versions are based on the same basic concepts, but they differ according to the type of decision problem to solve: selection problem, ranking problem or sorting problem. Precisely, the version ELECTRE I is used for selection problems, the versions ELECTRE II, ELECTRE III and ELECTRE IV are used for ranking problems and finally the version ELECTRE TRI is used for the sorting problems [4]. For more details on the ELECTRE methods, we refer the reader to the following references: [9]. The ELECTRE methods, and others analysis multicriteria methods, have been successfully applied to several concrete problems and domains, for example, we cite:

- a. Energy: [10], [17].
- b. Environment and Water Management: [21]
- c. Finance: [6], [25].
- d. Education and teaching: [22]
- e. Military: [2], [13]
- f. Transportation: [20]
- g. Civil Engineering: [12]
- h. Agriculture and Forest Management : [3], [23]
- i. Medical applications: [24]
- j. Automatic Image Annotation: [14]
- k. Data Mining and Big Data: [7]
- l. Etc.

The list of applications listed below is obviously not exhaustive.

### 3.2. ELECTRE III Method

Among ELECTRE methods, ELECTRE III is well known and has been widely used in practice. This method was introduced as an extension of the method ELECTRE II to consider the hesitation of the decision-maker (DM) between the preference relation  $P$  and the indifference relation  $I$ , see Figure 2. ELECTRE III has been successfully applied in recent decades on a wide range of practical applications, [11] The main difference between II and III is that they use different types of criteria. ELECTRE II uses the real-criteria where there are no thresholds, but the criteria used in ELECTRE III are the pseudo-criteria using different thresholds: preference threshold  $p$ , indifference threshold  $q$  and veto threshold  $v$ .

#### 3.2.1 Algorithm of the ELECTRE III Method

The ELECTRE III method proceeds in two steps:

- a. Step 1: Building the outranking relation  $S$

In this first step, the alternatives are compared between them. The output of this step is a matrix called the credibility matrix.

- b. Step 2: Exploitation of the outranking relation  $S$

Two pre-orders are then constructed with two antagonistic procedures (Ascending Distillation and Descending Distillation). The combination of these two pre-orders gives the final ranking to recommend to DM. The two steps are illustrated in Figure 1, The full description of the two steps is summarized in the following paragraphs.

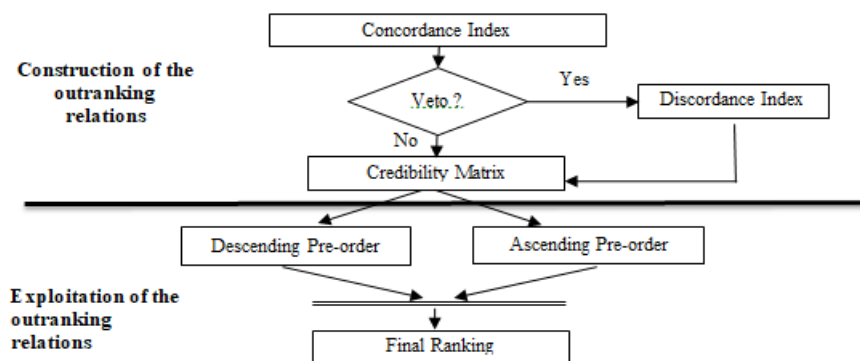

Figure 1. The flowchart of the process of the ELECTRE III method

**3.2.2.1 Description the Step 1 of ELECTRE III Algorithm: Construction the Outranking Relation and Calculating the Credibility Matrix**

For the description of the step 1 of ELECTRE III algorithm about the construction the outranking relation and calculating the credibility matrix.

For the rest of this article, we will use the following notations:

- a.  $F = \{g_1, \dots, g_j, \dots, g_m\}$  is the family of  $m$  criteria  $m \geq 2$ .
- b.  $J$  denotes the set of criteria indices.
- c.  $A = \{a_1, \dots, a_i, \dots, a_n\}$  is the set of alternatives.
- d.  $W = \{w_1, \dots, w_j, \dots, w_m\}$  is the weight vector reflecting the relative importance of the criteria.
- e.  $g_j(a_i)$  is the evaluation of the criterion  $g_j$  for the alternative  $a_i$ .

We define binary relational operators ( $P, Q, I$  and  $R$ ), to compare two alternatives,  $a$  and  $b$ , as follows:

- a.  $P$  is the strong preference relation,  $aPb$  means " $a$  is strongly preferred to  $b$ ".
- b.  $I$  is the indifference relation,  $aIb$  means " $a$  is indifferent to  $b$ ".
- c.  $Q$  is the weak preference relation,  $aQb$  means " $a$  is weakly preferred to  $b$ ". The relation  $Q$  expresses the hesitation of the decision makers between indifference  $I$  and preference  $P$ .
- d.  $R$  is the incomparability relation,  $aRb$  indicates that the action  $a$  and  $b$  are incomparable.
- e.  $S$  is the outranking relation,  $aSb$  indicates that " $a$  is at least as good as  $b$ ".

The thresholds of the ELECTRE III model are noted as follows:

- a.  $q_j$  is the indifference threshold for criterion  $g_j$ .
- b.  $p_j$  is the threshold of preference for criterion  $g_j$ .
- c.  $v_j$  is the veto threshold for criterion  $g_j$ .

These thresholds can be constant or variable depending on the scale of each criterion  $g_j$ , see the follow Figure 2.

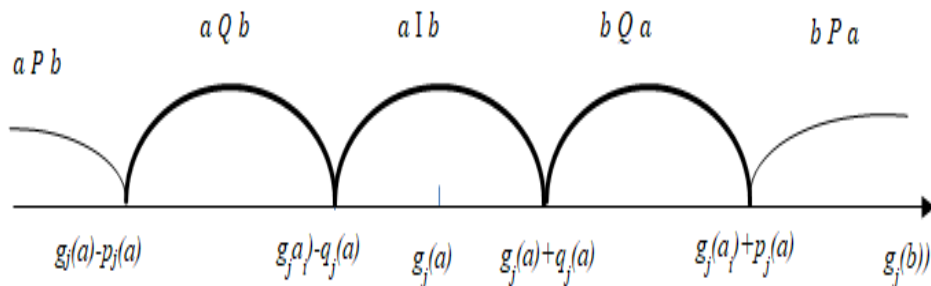

Figure 2. The indifference relation  $I$ , the weak preference relation  $Q$  and the strong preference relation  $P$

**3.2.2.2 Calculation of Concordance Index**

The construction of an outranking relation requires the definition of a credibility index for outranking relation  $aSb$ :  $\rho(a,b)$  denotes the credibility index. It is defined by using both a concordance index,  $c_j(a,b)$ , and a discordance index,  $d_j(a,b)$ , for each criterion  $g_j \in F$ . The concordance index is calculated by considering individually for each criterion  $g_j$  the support it provides to the assertion  $aSb$ . In ELECTRE III method, we calculate the concordance index  $c(aSb)$  as follows:

$$c(aSb) = \frac{\sum_{j=1}^m w_j c_j(a,b)}{\sum_{j=1}^m w_j} \tag{1}$$

Where  $c_j(a,b)$  is the partial index of concordance between alternatives  $a$  and  $b$  under criterion  $g_j$ .  $c_j(a,b)$  is calculate as the following Equation:

$$c_j(a, b) = \begin{cases} 0 & \text{if } g_j(b) - g_j(a) > p_j \\ 1 & \text{if } g_j(b) - g_j(a) \leq q_j \\ \frac{p_j + g_j(a) - g_j(b)}{p_j - q_j} & \text{otherwise} \end{cases} \tag{2}$$

The concordance matrix is then constructed and includes all  $c(aSb)$  for all pairs of alternatives.

### 3.2.2.3 Calculation of Discordance Index

A second index is calculated which is the discordance of a criterion  $g_j$ ; this index describes the veto effect that the criterion provides for the assertion  $aSb$ . For example, when we have a veto effect, it's that we refuse the assertion  $aSb$ . The discordance index is calculated separately for all criteria. A discordance index reaches its maximum value when the  $g_j$  vetoes the outranking relation, it is minimal when criterion  $g_j$  is not discordant with this relation. To define the value of the discordance index on the intermediate zone, a linear interpolation is used. The partial discordance index is calculated as follows, for all  $j \in J$ :

$$d_j(aSb) = \begin{cases} 0 & \text{if } g_j(b) - g_j(a) \leq p_j \\ 1 & \text{if } g_j(b) - g_j(a) > v_j \\ \frac{g_j(b) - g_j(a) - p_j}{v_j - p_j} & \text{otherwise} \end{cases} \quad (3)$$

### 3.2.2.4 Calculation of the Credibility Degree $\rho$

In the basic ELECTRE III method, the outranking relation is constructed by defining the credibility of the  $aSb$  assertion as follows:

$$\rho(aSb) = \begin{cases} c(aSb) & \text{if } d_j(aSb) \leq c(aSb) \forall j \in F \\ c(aSb) \prod_{j \in F} \frac{1 - d_j(aSb)}{1 - c(aSb)} & \text{otherwise} \end{cases} \quad (4)$$

The Equation 4 assumes that if the concordance index exceeds that of the discrepancy, the concordance value does not need to be modified for credibility degree. Otherwise, we must attenuate the concordance  $c(aSb)$  with respect to the assertion  $aSb$  according to the equation above. If the discordance index is 1 for at least one criterion  $g_j$ , then we have no credibility that  $aSb$ ; therefore,  $\rho(aSb)=0$ . Finally, for the construction of the outranking relation  $S$ , we put  $S(a,b)=\rho(aSb)$ .

### 3.2.3. Description of the step 2 for the algorithm ELECTRE III: Exploitation of the outranking Relation

The alternatives are ranked in two pre-orders, which are constructed the different ways. The first pre-order is obtained descendingly, called Descending Distillation, which consists to select initially the best-rated alternatives, and ending with the worst alternatives. The second pre-order is obtained ascendingly, called Ascending Distillation, which consists now, to begin selecting with the least-rated alternatives, and ending with the best ones. The two pre-orders that are defined according to a qualifying score for each alternative as follows:

a. Step 1: Define the index  $\lambda_0$ . This index is equal the maximum value of  $S(a,b)$  in the credibility matrix according to Equation 5.

$$\lambda_0 = \max_{a,b \in A} S(a,b) \quad (5)$$

b. Step 2: A cut-off level of outranking  $\lambda_1$  is defined as the largest outranking score, which is inferior than the maximum outranking score minus the discrimination threshold as per Equation 6.

$$\lambda_1 = \max_{S(a,b) < \lambda_0 - s(\lambda_0)/a, b \in A} S(a,b) \quad (6)$$

Where  $s(\lambda_0)$  is the discrimination threshold at the maximum level of outranking  $\lambda_0$ . This threshold is calculated in general by the formula given in Equation 7.

$$s(\lambda) = \alpha * \lambda + \beta \quad (7)$$

Generally, we choose  $\alpha = -0.15$  and  $\beta = 0.3$ . At the initial cut-off level,  $a$  outranks  $b$  if  $S(a,b)$  is strictly superior to the cut-off level and  $S(a,b)$  exceeds  $S(b,a)$  by more than the discrimination threshold satisfying the condition given in Equation 8.

$$aSb \text{ if } S(a,b) > \lambda_1 \text{ and } S(a,b) - S(b,a) > s(\lambda_1) \quad (8)$$

c. Step 3: Whenever  $S b, a$  receives a score +1 (strength) and  $b$  is given -1 (weakness). For each alternative, the strengths, noted by  $\varphi^+(a)$ , and the weaknesses, noted by  $\varphi^-(a)$ , are summed to give a final

qualification score, noted by  $\varphi(a)$ . The different scores are obtained by formulas (9), (10) and (11) as follows:

$$\varphi^+(a) = \sum_{b \in A/a} s_b + 1 \tag{9}$$

$$\varphi^-(a) = \sum_{b \in A/b} s_a + 1 \tag{10}$$

$$\varphi(a) = \varphi^+(a) - \varphi^-(a) \tag{11}$$

d. Step 4: In descending distillation, the alternative with the highest qualification score  $\varphi$  assigned to one rank and removed from the procedure, and the process is repeated for all remaining alternatives.

e. step 5: In the ascending distillation, the alternative with the lowest qualification score  $\varphi$  is assigned to one rank and removed from the procedure, and the process is repeated for all remaining alternatives.

f. Step 6: The results of the two procedures "Descending Distillation" and "Ascending Distillation" are combined to form a final ranking.

### 3.3. Numerical Results

Given the size of the BDMR database on rural Morocco, we illustrate the approach proposed in this paper with 15 centers dispersed throughout the Moroccan territory. Each center is evaluated on three criteria:  $g_1$  (population, which is a criterion to be maximized),  $g_2$  (cost of electrification, which is a criterion to be minimized) and criterion  $g_3$  (the internal rate of return of the project, which is a criterion to be maximized). All the results are verified with the ELECTRE III-IV version 3.a software, which was developed at the LAMSADE laboratory at Paris-Dauphine University, France.

#### 3.3.1. Decision matrix M

This matrix M contains the performances of all the centers on all the criteria ( $M(i,j)=g_j(a_i)$ ,  $1 \leq i \leq 15$  and  $1 \leq j \leq 3$ ). The performance matrix in our example is shown in Table 2.

Table 2. Decision Matrix

Center code	Criteria Alternatives Center name	province region	$g_2$ : Cost of Electrification (10 <sup>3</sup> DH)		$g_3$ : Internal Rate of Return
			$g_1$ : Population MAX	MIN	MAX
A1	Adrou	Sidi Kacem	3000	883	31.10
A2	Douar Jdid	Marrakech	5600	2932	21.90
A3	Talouete	Ouarzazate	9500	5972	21.90
A4	Boudnib IVSKOUR	Errachidia	10000	8280	21.30
A5	Ain toto	Meknès	4000	2162	24.00
A6	El Ansar	Taounate	2518	1706	26.40
A7	Chouiter	Marrakech	2400	1248	22.00
A8	Smair	Benimallal	2400	1165	18.10
A9	Ouled Mellouk	Casablanca	7000	4915	14.50
A10	Amzmiz	Marrakech	4100	2854	18.50
A11	EL harit morabit	Ouarzazate	4480	5438	15.30
A12	Tadighoust	Errachidia	6500	5292	18.80
A13	Talzemt	Boulmane	4500	2624	20.60
A14	Ikhorbane	Agadir	2500	1579	24.30
A15	Dr.Jdid and Laadir	Khmisset	3400	1641	23.00

MAX means that the criterion must be maximized, and MIN means that the criterion must be minimized.  
DH: Moroccan Dirham

#### 3.3.2. Choice of Criteria Thresholds

The decision matrix must be completed by the threshold table required for the ELECTRE III method, see Table 3. These thresholds are calculated for each criterion  $g_j \in F$  and each alternative  $a \in A$ . Often the following affine formulas are used:

$$\text{Indifference threshold: } q(g_j(a)) = \alpha_j1 g_j(a) + \beta_j1 \tag{12}$$

$$\text{Preference threshold: } p(g_j(a)) = \alpha_j2 g_j(a) + \beta_j2 \tag{13}$$

$$\text{Veto threshold: } v(g_j(a)) = \alpha_j3 g_j(a) + \beta_j3 \tag{14}$$

With:  $\alpha_{j1}$  and  $\beta_{j1}$  are the indifference threshold coefficients for criterion  $g_j$   
 $\alpha_{j2}$  and  $\beta_{j2}$  are the Preference threshold coefficients for criterion  $g_j$   
 $\alpha_{j3}$  and  $\beta_{j3}$  are the veto indifference threshold coefficients for criterion  $g_j$ .

Some particular cases of thresholds:

- If the thresholds are not relevant for a criterion considered, i.e. if you estimate that there is a true-criterion, you give 0 for the threshold coefficients.
- If you want to use a constant threshold for a criterion  $g_j$  considered, just take the coefficient  $\alpha_{ji}$  ( $i \in \{1,2,3\}$ ) null and the coefficient  $\beta_{ji}$  ( $i \in \{1,2,3\}$ ) not null.
- To define a threshold proportional to the performance, just take  $\beta_{ji}=0$ . For example, if you estimate, for a criterion with increasing preferences, that an alternative can be regarded as preferred without hesitation to another as soon as exceeds it by 10%, so you take for the performance threshold  $\alpha_{2j}=10/100=0.1$  and  $\beta_{j2}=0$ .

Table 3. Weight Values and Thresholds

Criteria	Weight (w)	Indifference (q)	Preference (p)	Veto (v)
$g_1$	1.50	$\alpha_{11}=5\% / \beta_{11}=0$	$\alpha_{12}=10\% / \beta_{12}=0$	Not considered
$g_2$	1.50	$\alpha_{21}=5\% / \beta_{21}=0$	$\alpha_{22}=10\% / \beta_{22}=0$	
$g_3$	2.00	$\alpha_{31}=5\% / \beta_{31}=0$	$\alpha_{32}=10\% / \beta_{32}=0$	

Example: for the alternative A1 on the criterion  $g_1$ , we have:

- The indifference threshold is:  $q_1(A1) = \alpha_{11} g_1(A1) + \beta_{11} = 3000 * 0.05 = 150$
- The preference threshold is:  $p_1(A1) = \alpha_{12} g_1(A1) + \beta_{12} = 3000 * 0.1 = 300$

**3.3.3. Results of the ELECTTE III method**

After determining the necessary input data, the ELECTRE III method was applied and the credibility matrix was obtained. Then, the distillation procedure is applied to obtain the two descending and ascending pre-orders. Finally, the results of the two procedures, descending distillation and ascending distillation, are combined to form a final ranking, see Figure 3.

According to the results of the choices evaluated by the method ELECTRE III, the center A1, the village "Adrou" of the province of "Sidi Kaecm", is considered then as the highest priority of all the other centers for a possible electrification. The final ranking obtained, the electrification of the A1 center can be linked with the A2 center ("Douar Jdid of the province of "Marrakech") and A5 ("Ain Toto" of the province of "Meknes") and so forth.

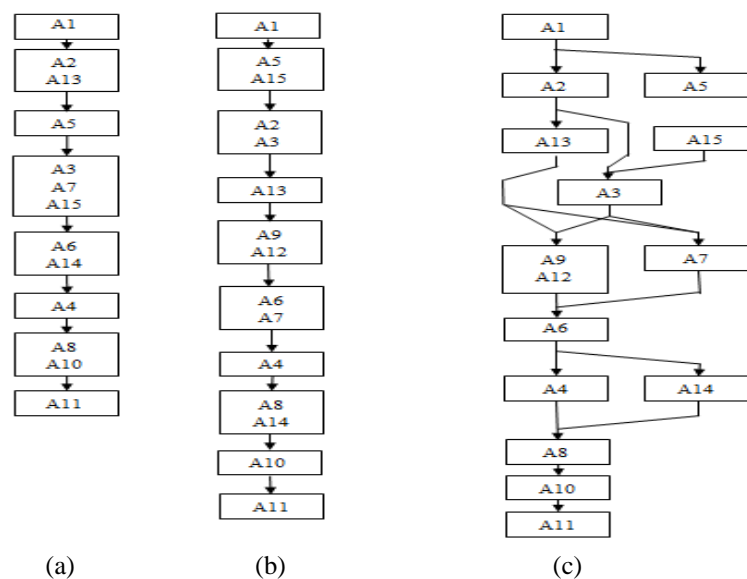

Figure 3. (a) Descending distillation, (b) Ascending distillation, (c) Ranking final



**3.3.4. Robustness Analysis**

In problems of multicriteria decision aid, it is always recommended to start assigning indifference and preference thresholds that seem best to define a reference set, and then deviate from these thresholds in a reasonable way to conduct a robustness analysis [19]. This robustness analysis consists to find and validate the most stable and robust solutions.

In this study, the rate of stability in the evaluation of choices was examined by modifying the p and q parameters to ± 10% and ± 20%, see Table 4. The results showed that the acquired stability is almost 90%. Almost all the alternatives have kept the same order of priority compared to the others, except for the alternatives A10, A14, A9 which have improved their ranking by two levels. The A8 choice is the only one that has moved from a higher to lower priority of three levels lower. The results for the sensitivity analysis are shown in Table 5.

Table 4. Robustness Analysis: 10% and 20% Change in the q and p Thresholds

Criteria	(q)		(p)		(q)		(p)	
	-10%	+10%	-10%	+10%	-20%	+20%	-20%	+20%
g1	$\alpha_{11}=0.045$ $\beta_{11}=0$	$\alpha_{11}=0.055$ $\beta_{11}=0$	$\alpha_{12}=0.09$ $\beta_{12}=0$	$\alpha_{12}=0.11$ $\beta_{12}=0$	$\alpha_{11}=0.04$ $\beta_{11}=0$	$\alpha_{11}=0.06$ $\beta_{11}=0$	$\alpha_{12}=0.08$ $\beta_{12}=0$	$\alpha_{12}=0.12$ $\beta_{12}=0$
g2	$\alpha_{11}=0.045$ $\beta_{11}=0$	$\alpha_{11}=0.055$ $\beta_{11}=0$	$\alpha_{12}=0.09$ $\beta_{12}=0$	$\alpha_{12}=0.11$ $\beta_{12}=0$	$\alpha_{11}=0.04$ $\beta_{11}=0$	$\alpha_{11}=0.06$ $\beta_{11}=0$	$\alpha_{12}=0.08$ $\beta_{12}=0$	$\alpha_{12}=0.12$ $\beta_{12}=0$
g3	$\alpha_{11}=0.045$ $\beta_{11}=0$	$\alpha_{11}=0.055$ $\beta_{11}=0$	$\alpha_{12}=0.09$ $\beta_{12}=0$	$\alpha_{12}=0.11$ $\beta_{12}=0$	$\alpha_{11}=0.04$ $\beta_{11}=0$	$\alpha_{11}=0.06$ $\beta_{11}=0$	$\alpha_{12}=0.08$ $\beta_{12}=0$	$\alpha_{12}=0.12$ $\beta_{12}=0$

Table 5. Robustness Analysis: 10% and 20% Change in the q and p Thresholds

Rank	Results							
	(q)-10%	(q)+10%	(p)-10%	(p)+10%	(q)-20%	(q)+20%	(p)-20%	(p)+20%
1	A1	A1	A1	A1	A1	A1	A1	A1
2	A2, A5	A2, A5	A2, A15	A2, A5	A2, A5	A2, A5	A2, A5	A2, A5
3	A13, A15	A13, A15	A3, A5, A7, A13	A13, A15	A13, A15	A13, A15	A13, A15	A13, A15
4	A3	A3	A9	A3	A3	A3	A3	A3
5	A7, A9, A12	A7, A9, A12	A12	A7, A9, A12	A7, A9, A12	A7, A9, A12	A9, A12	A7, A12
6	A6	A6, A10	A4, A8, A14	A6, A10	A6	A6, A10	A6, A7	A9, A10
7	A4, A14	A4, A14	A6, A10	A4, A14	A4, A14	A4, A14	A4, A14	A6
8	A8	A8	A11	A8	A8	A8	A8	A4, A14
9	A10	A11		A11	A10	A11	A10	A8
10	A11				A11		A11	A11

**4. RESULTS AND DISCUSSION**

After the robustness analysis, summarized in Table 5, the recommendation to propose to the decision maker is to begin the electrification operation with the centers A1, A2 and A5. Indeed, these three centers always occupy the first places for the different rankings obtained. While the A11, A10 and A8 centers rank in the last ranks and remains the worst choices.

In this work, we should have used another multicriteria aggregation method, such as for example the weighted sum method, known to almost everyone. Indeed, this method is simple in its use and doesn't introduce many parameters, such is the case of the ELETRE III method. However, the weighted sum method has some limitations, because this method assumes that all the criteria are expressed on the same scale of measurement and it induces the effect of compensation between criteria, that is, any weakness on one criterion may be compensated on another criterion. For the approach proposed in this paper, it doesn't suppose any constraint on the scales of measurement of all the criteria and can be so used without problem for many cases where the criteria are measured differently on heterogeneous scales of measurement. Also, this approach, which is obviously the method ELECTRE III is a non-compensatory method, indeed, it is based only on the pairwise comparisons between alternatives, the principle of the majority and the effect of veto.

In conclusion of this discussion, we can confirm that for certain multicriteria decision problems, as it's the case for the present application of the Moroccan Rural Electrification Program, the ELECTRE III method is considered as the most adapted that the weighted sum method.

## 5. CONCLUSION

In this paper, we made use of the famous method of multicriteria decision aid ELECTRE III. It was used to select the priority localities for the global electrification program of the Moroccan rural world. The method has compared the pairs of candidate localities and led to a very stable solution. Indeed, a robustness analysis was carried to evaluate the rate of stability in the recommendation to be retained and finally to propose to the decision-makers. Given the real size of this problem, more than 30000 alternatives and more than 20 criteria, and the algorithmic complexity, the application of the ELECTRE III method rests technically very difficult because of the time required to run the algorithm. The application of other multicriteria methods or at least the adaptation of the ELECTRE III method to large problems, especially when we have a very large data size, constitutes one of the purposes of our research in the future.

Finally, we confirm and emphasize that the GREP program, initiated in the first by the Moroccan government, has reached currently almost all these desired objectives. Indeed, the electrification rate of the rural world is improved to 99%, it remains so a very satisfactory rate. However, it becomes necessary now to make more efforts for the others basic infrastructures, mainly concerning the potable water and the connection the rural world to the national road network, in order to guarantee in final, the global development of the rural world and put an end to the suffering of rural population, which lasted for a long time.

## ACKNOWLEDGEMENTS

The authors would like to acknowledge all the responsible of the LISA laboratory from the University Sidi Mohamed Ben Abdellah of Fez, Morocco, for the material as well as the financial support to concretize and to succeed well our research works. The authors would like also to acknowledge the Director General of the SIGMATECH research office, located in Rabat, Morocco, professor Abdelhanin Ben Allou for giving us the opportunity to work on the Moroccan rural electrification project.

## REFERENCES

- [1] Evaluation du projet Fès-Kariat-Tissa, Direction de la Planification et des Affaires Economiques. (1991). Marrakech.
- [2] A., W. (1997). case-study in military decision-making with mission-oriented multiple objectives. In J. Clímaco, editor, *Multicriteria Analysis*. Springer Verlag, Berlin, 549–560.
- [3] Arondel, & Girardin, P. (2000). Sorting cropping systems on the basis of their impact on groundwater quality. *European Journal of Operational Research*, 127, 467–482.
- [4] Bouyssou, D. (1993). *Décision Multicritère ou aide multicritère ? Newsletter of the European*.
- [5] Brans, J., Mareschal, B., & Vincke, P. (1984). PROMETHEE: A New Family of Outranking Methods in Multicriteria Analysis. . (E. S. B.V, Ed.) *Operational Research*, 80, 408–421.
- [6] Dimitras, A., Zopounidis, C., & Hurson, C. (2001). Assessing financial risks using a multicriteria sorting procedure: The case of country risk assessment. *Foundations of Computing and Decision Sciences*, 97–109.
- [7] El Mazouri, F. Z., Abounaima, M. C., & Zenkouar, K. (November 14 - 16, 2017). A Selection of Useful Patterns Based on Multi-Criteria Analysis Approach. *ACM DL Proceedings of the 2nd International Conference on Computing and Wireless Communication Systems( ICCWCS'17)*, (p. Article No. 31 ). Larache, Morocco.
- [8] Figueira, J., & al. (2013). An Overview of ELECTRE Methods and Their Recent Extensions. *Journal of Multi-Criteria Decision Analysis*, 20, 61-85.
- [9] Figueira, J., Roy, B., & Mousseau, V. (2005). *ELECTRE methods*. (S. S. Business, Ed.) *Multiple Criteria Decision Analysis : State of the Art Surveys*, New York, U.S.A.: Springer Science + Business Media, 133-162.
- [10] Georgopoulou, E., Sarafidis, Y., Mirasgedis, S., Zaimi, S., Lalas, & D. (2003). A multiple criteria decision-aid approach in defining national priorities for greenhouse gases emissions reduction in the energy sector. *European Journal of Operational Research*, 199–215.
- [11] Giannoulis, C., & Ishizaka, A. (2010). A Web-based Decision Support System with ELECTRE III for a Personalised Ranking of British Universities. *Decision Support Systems*, 48(3), 488–497.
- [12] Hadikurniawati, W., & Mustofa, K. (2016, October). Multicriteria Group Decision Making Using Fuzzy Approach for Evaluating Criteria of Electrician . *International Journal of Electrical and Computer Engineering (IJECE)*, 6(5), 2462~2469.
- [13] Hamid, E. A., & Masoud, P. ( 2014). Application of the multi-criteria decision method ELECTRE III for the Weapon selection. *Decision Science Letters*, 511–522.
- [14] Hengame, D., & Ahmad, R. E. (2014, February). A Novel Semantic Statistical Model for Automatic Image Annotation Using the Relationship between the Regions Basedon Multi-Criteria Decision Making. *International Journal of Electrical and Computer Engineering (IJECE)*, 4(1), 37-51.
- [15] l'énergie, D. d. (1989). *Etude de l'Impact Socio-Economique du premier Programme Nationl d'Electrification Rural*.
- [16] Ministère de l'Énergie et des Mines, D. d. (1987). *Etude de l'Impact Socio-Economique du PERG et Elaboration du PERG II*. Rabat.

- [17] Papadopoulos, A., & Karagiannidis, A. (2008). Application of the multi-criteria analysis method Electre III for the optimisation of decentralised energy systems. *Omega*, 36(5), 766-776.
- [18] ROY, B. (1968). Classement et choix en présence de points de vue multiples (la méthode ELECTRE). *Françaised Informatiqueet de RechercheOpérationnelle*, 8, 57-75.
- [19] Roy, B. (2010, February). Robustness in operational research and decision aiding : A multi-faceted issue. *European Journal of Operational Research*, 200(3), 629–638.
- [20] Roy, B., & Hugonnard, J. (1982). Ranking of suburban line extension projects on the Paris metro system by a multicriteria method. *Transportation Research*(16A (4)), 301–312.
- [21] Roy, B., Slowinski, R., & Treichel, W. (1992). Multicriteria programming of water resources supply systems for rural areas. *Water Resources Bulletin*, 13–31.
- [22] Sudarma, M., Oka, A. A., & Cahya, I. (2015, February). Decision Support System for the Selection of Courses in the Higher Education using the Method of Elimination Et Choix Tranduit La Realite. *International Journal of Electrical and Computer Engineering (IJECE)*, 5( 1), 129-135.
- [23] Teclé, & Duckstein, L. (1992). A procedure for selecting MCDM techniques for forest resources management. *Multiple Criteria Decision Making and Support at the Interface of Industry, Business and Finance*, Springer Verlag, New York, 19–32.
- [24] Ying-Chieh, F., & Chiu-Cheng, C. (2014, March). A Multicriteria Selection Model for Developing New Color Calibration Device. *TELKOMNIKA Indonesian Journal of Electrical Engineering*, 12(3), 2374-2383.
- [25] Zopounidis. (1998). *Operational Tools in the Management of Financial Risks*. Dordrecht: Kluwer Academic Publishers.

## BIOGRAPHIES OF AUTHORS



Fatima Zahra El Mazouri received the Master Degree in Intelligent Systems and Computer Science from the Faculty of Sciences and Technologies of the University Mohamed Ben Abdellah, Fez, Morocco in 2015. She is currently working toward the Ph.D. degree in sciences and techniques at Faculty of Sciences and Technologies of the University Mohamed Ben Abdellah, Fez, Morocco. She is currently involved in the application of multicriteria decision aid methods to several decision domains.



Mohammed Chaouki ABOUNAIMA was born in the Meknes city at Morocco in 1967. He received the PH.D. degree in Computer Science from the Mohammed V University, Rabat, Morocco, in 1997. He is currently a professor at the Department of Computer Engineering, Faculty of Science and Technology Fez Morocco. He is a member in the Laboratory of Intelligent System & Applications. His research focuses on the methods and techniques of multi-criteria decision aid.



Khalid Znkouar received his Ph.D. degree in image analysis from Faculty of Sciences, University Sidi Mohamed Ben Abdellah, Fez, Morocco in 2006. Now he is a professor at the Department of Computer Engineering, Faculty of Science and Technology Fez Morocco. He is a member in the Laboratory of Intelligent System & Applications. His current research interests include image analysis, machine intelligence and pattern recognition, and he is also involved in the multi-criteria decision making.



Ahmed El Hilali Alaoui obtained his Ph D. degree in 1996 from the University Abdel Malek Essaadi, Faculty of Sciences of Tetouan, Morocco. Presently, he is a professor at the Faculty of Sciences and Technologies of Fes, University of Sidi Mohamed Ben Abdellah, Morocco, where he was responsible for the laboratory of Modelling and Scientific Computing. Now he heads the Operational Research and Information Technologies Team, and he is also responsible for the Master of Mathematics and Applications in Scientific Computing. Currently, his research is focused on mathematical models applied to the green logistics. Many Ph D. students worked under his direction.