

Economic Dispatch using Quantum Evolutionary Algorithm in Electrical Power System involving Distributed Generators

Ni Ketut Aryani¹, Adi Soeprijanto², I Made Yulistya Negara³, Mat Syai'in⁴

Department of Electrical Engineering, Institut Teknologi Sepuluh Nopember (ITS), Surabaya, Indonesia

Article Info

Article history:

Received Oct 25, 2016

Revised Jun 5, 2017

Accepted Jun 19, 2017

Keywords:

Distributed generation

Economic dispatch

Quantum genetic algorithm

ABSTRACT

Unpredictable increase in power demands will overload the supply subsystems and insufficiently powered systems will suffer from instabilities, in which voltages drop below acceptable levels. Additional power sources are needed to satisfy the demand. Small capacity distributed generators (DGs) serve for this purpose well. One advantage of DGs is that they can be installed close to loads, so as to minimise losses. Optimum placements and sizing of DGs are critical to increase system voltages and to reduce losses. This will finally increase the overall system efficiency. This work exploits Quantum Evolutionary Algorithm (QEA) for the placements and sizing. This optimisation targets the cheapest generation cost. Quantum Evolutionary Algorithm is an Evolutionary Algorithm running on quantum computing, which works based on qubits and states superposition of quantum mechanics. Evolutionary algorithm with qubit representation has a better characteristic of diversity than classical approaches, since it can represent superposition of states.

Copyright © 2017 Institute of Advanced Engineering and Science.
All rights reserved.

Corresponding Author:

Ni Ketut Aryani,

Power System Simulation Lab, Department of Electrical Engineering,

Institut Teknologi Sepuluh Nopember (ITS), Surabaya, Indonesia.

Email:ketut.aryani@gmail.com

1. INTRODUCTION

Distributed generation has an important role in a modern and complex electrical power system. DGs are of small sizes, high efficiencies, low investment costs and the most importantly is their ability to run on renewable energy sources. DGs can also provide stand-alone remote applications with their required power. However, improper placement of Distributed Generation will result in increased system losses, resulting in higher costs. Placements and sizings of DG are critical to the overall system efficiency.

The use of distributed generator in the system has some advantages in terms of economic, technical and environmental. Environmental advantages entail reductions of sound pollution and emission of gases. The economical advantages are reductions in transmission and distribution costs, electricity prices and savings on fuel. Technical advantages cover wide varieties of benefits, for examples, line loss reduction, increased system voltage profiles and increased power stability and reliability. It can also provide stand-alone remote applications with their power need.

Planning of an electrical power systems involving DGs requires the definition of several factors, such as: the best technology and method to use, the number and the capacity of the units, the best location, the network connection way, and alike-

Researchers have used evolutionary computational methods for economic dispatch. Joko Pitono used the sigmoid decreasing inertia weight PSO for calculating Hybrid Optimization of Emission and Economic Dispatch [1], Hybrid Optimization of Emission and Economic Dispatch by the Sigmoid Decreasing Inertia Weight Particle Swarm Optimization, this paper proposed technique of optimization which combined fuel cost economic optimization and emission dispatch using the Sigmoid Decreasing

Inertia Weight Particle Swarm Optimization algorithm (PSO) to reduce the cost of fuel and pollutants resulted. Leandro dos Santos Coelho a,*, Chu-Sheng Lee b, using chaotic and Gaussian particle swarm optimization Solving economic load dispatch problem [2]. Hossein Shahinzadeh used Particle Swarm Optimization algorithm to solve the economic load dispatch of units in power systems with valve-point effects consideration [3]. PSO is used for the solution of Dynamic Economic Load Dispatch (DELD) problem with valve point loading effects and ramp rate limits in the paper written by G.Sreenivasan [4].

Important issues in electric power industries are effectively economically optimum operations of electric power generation systems. The main utility target is to achieve the minimum operating cost and system stability. As well as to find the minimum operating cost using economic dispatch method. There are several kinds of methods to calculate the operating costs. Lagrange is the most commonly used to calculate the minimum cost of electrical energy generation [5]. In addition to this method there are several others that have been developed by researchers.

Quantum theory has been used widely in the field of electrical energy systems. In several publications, quantum EAs are utilized to calculate economic dispatch. For example in the references [6], [7] and [8]. Quantum-Inspired Evolutionary Algorithm for Real and Reactive Power Dispatch, in this paper, QEA determines the settings of control variables, such as generator outputs, generator voltages, transformer taps and shunt VAR compensation devices for optimal P-Q dispatch considering the bid-offered cost [6].

Chaotic Quantum Evolutionary Algorithm is used to solve Environmental Economic Dispatch of Smart Microgrid Containing Distributed Generation System Problems. Quantum evolutionary algorithm is used to confirm the accuracy and validity of the mathematical model used for determining environment and economic dispatch of Smart Micro Grid, which is considered as generation cost and emission cost [9].

In this work, quantum evolutionary algorithm is used for the placement of DGs in the network and for determining the capacity required to raise the voltage on the buses, so that the voltage at each bus is in safe condition and increases the system load ability. Finally, we perform the calculation for the economic dispatch to get the cheapest cost of generation. Quantum evolutionary algorithm is also used in similar way in reference [10],[11].

2. RESEARCH METHOD

2.1. Economic Dispatch Theory

The mathematical formulation of the total cost function is formulated as follows:

$$\min C = \sum_{i=1}^n C_i(P_i) + \sum_{g=1}^h C_g(P_g) \quad (1)$$

where C_i is the total fuel cost for the i th generator (in \$/h).

Generally, the fuel cost of thermal generating unit is represented in polynomial function,

$$C_i(P_i) = a_i + b_i P_i + c_i P_i^2 \quad (2)$$

where a_i , b_i and c_i are cost coefficients of generator i .

The DG generation cost.

$$C_g(P_g) = d_g G_g \quad (3)$$

where d_g is cost coefficients of DG

Conventionally, there is no or negligible DG capacity existing in the power system. In economic dispatch, the system demand and delivery loss are served by utility generators only. With the outspread of DG's in distribution networks, the non DG system evolves into a hybrid generation environment. The DG generation capacity has to be taken into account in the new environment. To achieve this, a modification of the conventional economic dispatch. In addition, N generators are connected to the system. The power balance constraint becomes:

$$\sum_N P_i + \sum_h P_g = P_D + P_{loss} \quad (4)$$

where $\sum_i P_i$ is the total power generated by utility generators and $\sum_g P_g$ is the total power from DG installed in buses, while P_D is total load and P_{loss} is total losses of the system.

Consequently, the generation cost consists of two parts: the power generated from existing and power from DG in load bus.

$$C_{Tot} = \sum_N C_i + \sum_h C_g \quad (5)$$

C_T is obtained by economically dispatching load and delivery loss among these online generators and DGs. Some constraints for each generator must be also satisfied. Generation power of each generator should be laid between maximum and minimum limits. The constraint for each generator is

$$P_i^{min} \leq P_i \leq P_i^{max} \quad (6)$$

where P_i^{min} and P_i^{max} are the output of the minimum and maximum operation of the generating unit i (in MW), respectively.

Voltage at load buses

$$V_i^{min} < V_i < V_i^{max} \quad (7)$$

where V_i^{min} and V_i^{max} are voltage minimum and maximum each buses.

Line Power Flow

Newton Rapson (NR) is a very common method used to calculate the power flow on the system. The NR power flow is used to calculate the losses in the system and the voltage on each bus. The theory of power flow used in this paper refers to the reference [5].

Injected Power

The complex power at bus ' i ' is:

$$S_i^* = V_i^* \sum_{k=1}^n Y_{ik} V_k \quad (8)$$

The variables updated after k th iteration are given as:

$$\Delta \delta_i^{(k+1)} = \Delta \delta_i^{(k)} + \Delta \delta_i \quad (9)$$

$$|V_i|^{(k+1)} = |V_i|^{(k)} + \Delta |V_i| \quad (10)$$

Power flow from i th bus to j th bus through the line connected between these buses is given by:

$$S_{ij} = V_i I_{ij}^* = V_i \left(\frac{V_i - V_j}{Z_{ij}} + V_i Y_{ij0} \right) \quad (11)$$

The power flow from the j th bus to i th bus is:

$$S_{ji} = V_j I_{ji}^* = V_j \left(\frac{V_j - V_i}{Z_{ji}} + V_j Y_{ji0} \right) \quad (12)$$

Line Losses

$$P_l = \sum_{i=1}^{bus\ no} \sum_{j=1}^{bus\ no} (S_{ij} + S_{ji}) \quad (13)$$

$$= \sum_{i=1}^{bus\ no} \sum_{j=1}^{bus\ no} \{ (P_{ij} + jQ_{ij}) + (P_{ji} + jQ_{ji}) \} \quad (14)$$

2.2. Quantum Evolutionary Algorithm (QEA)

The base theories of Quantum Evolutionary Algorithm method are the concepts of qubits and the superposition of states of quantum mechanics. Qubit is the smallest unit of information stored in a two-state quantum computer. A qubit may be in the state '1' or in the state '0' or in any superposition of the two. The state of a qubit can be represented as,

$$|\psi\rangle = |\alpha|^2 + |\beta|^2 \quad (15)$$

As also illustrated in figure 1, α and β are complex numbers specifying the probability amplitudes of the state '0' and '1' respectively. $|\alpha|^2$ gives the probability that the qubit will be found in '0' state and $|\beta|^2$ gives the probability that the qubit will be found in the '1' state. Normalization of the state to unity guarantees,

$$|\alpha|^2 + |\beta|^2 = 1 \quad (16)$$

2^m states can be represented at the same time by a system of m qubits. QGA is based on the concept of qubits. One qubit is defined with a pair of complex numbers (α, β) as,

$$\begin{bmatrix} \alpha \\ \beta \end{bmatrix} \quad (17)$$

which is characterized by (8) and (9). And an m -qubits representation is defined as

$$\begin{bmatrix} \alpha_1 | \alpha_2 | \dots | \alpha_m \\ \beta_1 | \beta_2 | \dots | \beta_m \end{bmatrix} \quad (18)$$

where $|\alpha_i|^2 + |\beta_i|^2 = 1, i = 1, 2, 3, \dots, m$

The advantage of this representation is that it can represent any superposition of states. For instance, in a three qubits system with three pairs of amplitudes such as,

$$\begin{bmatrix} \frac{1}{\sqrt{2}} | \frac{\sqrt{3}}{2} \\ \frac{1}{\sqrt{2}} | \frac{1}{2} \end{bmatrix} | 1.0 \\ 0 \end{bmatrix} \quad (19)$$

The state of the system can be represented as,

$$\frac{\sqrt{3}}{2\sqrt{2}} |000\rangle + 0 |001\rangle + \frac{1}{2\sqrt{2}} |010\rangle + 0 |011\rangle + \frac{\sqrt{3}}{2\sqrt{2}} |100\rangle + 0 |101\rangle + \frac{1}{2\sqrt{2}} |110\rangle + 0 |111\rangle$$

The above result means that the probabilities to represent the state $|000\rangle, |010\rangle, |100\rangle$ and $|110\rangle$ are $\frac{3}{8}, \frac{1}{8}, \frac{3}{8}$ and $\frac{1}{8}$ respectively. The three qubits system of (11) has four states information at the same time. Evolutionary algorithm with qubit representation has a better characteristic of diversity than classical approaches, since it can represent superposition of states. One qubit string such as (11) is enough to represent four states. Convergence can be also obtained with the qubit representation. As $|\alpha|^2$ or $|\beta|^2$ approaches to 1 or 0, the qubit string converges to a single state and the property of diversity disappears gradually. That is, simultaneously, the qubit representation has both the characteristic of exploration and the characteristic of exploitation.

Rotation Gate [10]

Q-gate (rotation gate) is defined as a variation operator of QEA, by which operation any updated qubit should at all time satisfy the normalization condition, $|\alpha'|^2 + |\beta'|^2 = 1$, where α' and β' are the values of the updated qubit.

The following rotation gate is used as a qubit:

$$\begin{bmatrix} \alpha_j(t+1) \\ \beta_j(t+1) \end{bmatrix} = R_i(t) \times \begin{bmatrix} \alpha_j(t) \\ \beta_j(t) \end{bmatrix} \quad (j = 1, 2, \dots, n) \quad (20)$$

$$R_i(t) = \begin{bmatrix} \cos \Delta\theta_i & -\sin \Delta\theta_i \\ \sin \Delta\theta_i & \cos \Delta\theta_i \end{bmatrix} \quad (i = 1, 2, \dots, n) \quad (21)$$

$\Delta\theta_i$ is a rotation angle (Fig.1) of each member of the population. The rotation angle $\Delta\theta_i$ is related to the normalized difference Δf_i between achievement of each of member of population and the global best optimum.

$$\Delta\theta_i = \Delta f_i \times \text{sign}(\alpha_b - \alpha_j) \times \text{sign}[\beta_j \times \sin \Delta f_i - \alpha_j \times (1 - \cos[\Delta f_i])] \quad (22)$$

where :

$$\Delta f_i = \pi \times \left(1 - \frac{f(b)}{f(p_i(t))}\right) \quad (i = 1, 2, \dots, n) \tag{23}$$

$$\text{sign}(\alpha_b - \alpha_j) = \begin{cases} +1 & \text{if } \alpha_b \geq \alpha_j \\ -1 & \text{if } \alpha_b < \alpha_j \end{cases} \tag{24}$$

$$\text{sign}[\beta_j \times \sin \Delta f_i - \alpha_j \times (1 - \cos \Delta f_i)] = \begin{cases} +1 & \text{if } \beta_j \times \sin \Delta f_i \geq \alpha_j \times (1 - \cos \Delta f_i) \\ -1 & \text{if } \beta_j \times \sin \Delta f_i < \alpha_j \times (1 - \cos \Delta f_i) \end{cases} \tag{25}$$

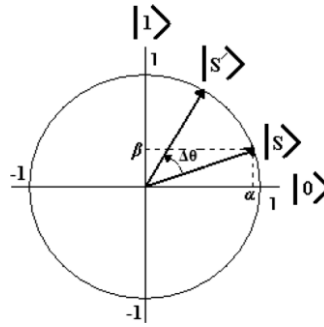

Figure 1. Basic Quantum-bit (qubit)

2.3. Problem Formulation

The objective function of this proposed method is :

$$\min C = \sum_{i=1}^n C_i(P_i) + \sum_{g=1}^h C_g(P_g) \tag{26}$$

where C_i is the total fuel cost for the i th thermal generator (\$/h), C_g is the total cost for generated power of DG (\$/h).

Bus voltage constrain:

$$|V_{i \min}| \leq |V_i| \leq |V_{i \max}| \tag{27}$$

Capacity DG constrain :

$$P_{g \min} \leq P_g \leq P_{g \max} \tag{28}$$

2.4. The Proposed Method

The proposed method can be described in the following steps and the flowchart of the algorithm is in figure 2.

1. Start with $t = 0$
2. Initialize a population of n members (qubit string) :

$$Q(0) = \{q_1(0), q_2(0), \dots, q_n(0)\}$$

3. Each qubit string is represented:

$$q_1(0) = \left[\begin{array}{c} |\alpha_1(0)| \quad |\alpha_2(0)| \quad \dots \quad |\alpha_m(0)| \\ |\beta_1(0)| \quad |\beta_2(0)| \quad \dots \quad |\beta_m(0)| \end{array} \right]$$

4. For all qubit strings initialize the amplitude amplification at :

$$q_1(0) = \left[\begin{array}{ccc} \frac{1}{\sqrt{2}} & \frac{1}{\sqrt{2}} & \dots \\ \frac{1}{\sqrt{2}} & \frac{1}{\sqrt{2}} & \dots \end{array} \right]$$

5. Randomly, make a set binary solution $P(0)$ by observing $Q(0)$ state :

$$P(0) = \{p_1(0), p_2(0), \dots, p_n(0)\}$$

6. Each DG is represented by 8 bit binary number. The MSB (*Most Significant Bit*) signifies whether the DG is present. If this bit is 1, DG is present at the bus and this DG's output power is determined

- by the rest 7 bits and also based on the P_{min} and P_{max} specified in the input parameter matrix. If the MSB is 0, DG is not present and the bus is considered as load bus.
7. Evaluate each $p_i(0)$ ($i = 1, 2, \dots, n$), prepare bus data matrix
 8. Using the bus data, run load flow and obtain power generated by each generator.
 9. Calculate the objective function and store the fitness value. For this economic dispatch, we use (26) as the objective function.
 10. Perform steps (5) – (7) for each population member.
 11. Find population member with the highest fitness value and store this as the best string of the iteration.
 12. Next iteration ($t = t + 1$)
 13. Generate the next population from the current population by rotating each member such that the new generation is closer to the best string. See fig 1. Rotation is done by rotator matrix that is calculated as per equations (20) - (21).
 14. Perform steps (4) - (10) as many times as needed.
 15. The most optimum solution is the best string of the last iteration.

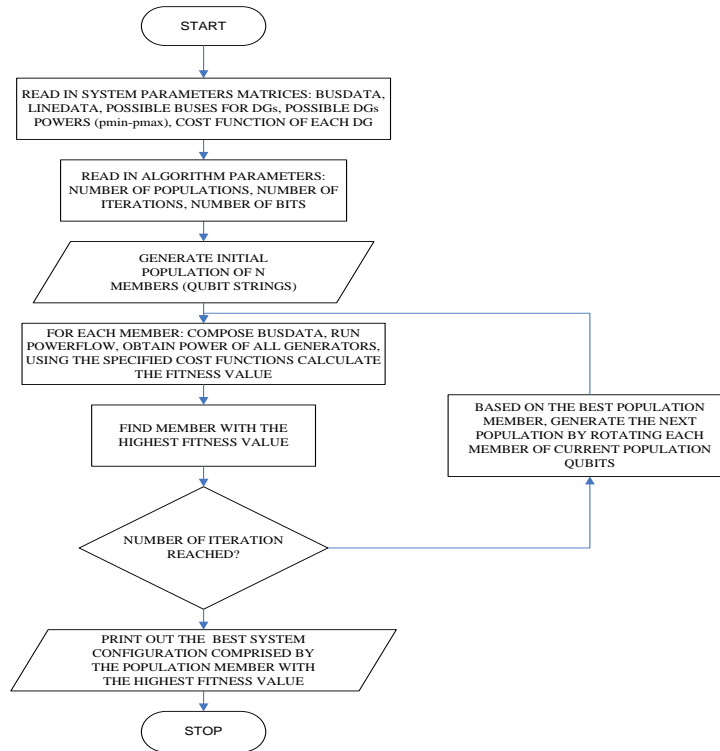

Figure 2.The Flowchart

3. RESULTS AND ANALYSIS

This work exploits IEEE 30-bus systems (system with 100MVA base, 135 KV base and frequency as 60Hz) to evaluate the performance of the proposed algorithm. In this system, the buses 1, 2, 5, 8, 11, and 13 are generator buses and others are load buses as shown in Figure 3. The generators parameters are in table 1. Power Generation Limits And Cost Generated Coefficients

Table 1. Generator data

Bus	p_i^{min}	p_i^{max}	Q_i^{min}	Q_i^{max}	a	b	c
-----	-------------	-------------	-------------	-------------	-----	-----	-----

1	50.00	200.0	-	-	0	2.00	$49.5 \cdot 10^{-4}$
2	20.00	80.00	-40.00	50.00	0	1.75	$175.0 \cdot 10^{-4}$
5	15.00	50.00	-40.00	40.00	0	1.00	$625.0 \cdot 10^{-4}$
8	10.00	35.00	-10.00	60.00	0	3.25	$83.0 \cdot 10^{-4}$
11	10.00	30.00	-6.00	24.00	0	3.00	$250.0 \cdot 10^{-4}$
13	12.00	40.00	-6.00	24.00	0	3.00	$250.0 \cdot 10^{-4}$

In this simulation, system is operated in critical condition, in which the voltage of some of the buses

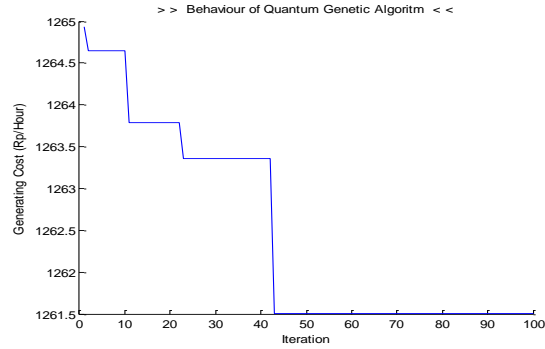
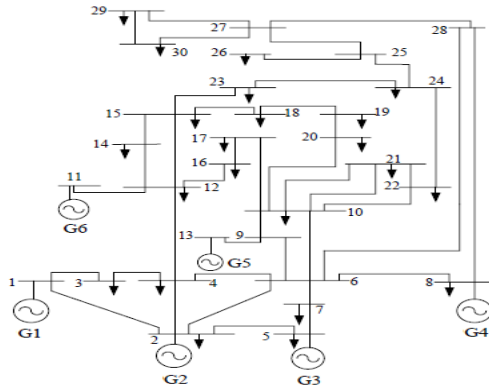

Figure 3. Single Line Diagram of The IEEE 30 Bus Power System Figure 4 . The Convergence of Economic Dispatch

approaches the minimum allowable value. This is achieved by increasing the initial load by a small step every time and then performing power flow calculation to get the voltage. As soon as the voltage falls out of allowable range of $0.9 \leq V_i \leq 1.1 pu$ (as per IEEE standard for voltages on the buses), the load can be considered as the maximum load of the system. At this maximum load, DGs start participating.

DGs are meant to enhance the capability of the power system (system load ability) and to improve voltage profile. So as to bring voltages on the buses back up in the normal range of $0.9 \leq V_i \leq 1.1 pu$ again. Apart from voltage profile improvement, renewable generation placement and sizing are important part of the economic dispatch strategy to minimize the overall generation cost. In this work, QEA is used to devise the placement and the size of the generators in the system. The solution is near optimum and still meets standard voltage profile requirement. DG posted on this simulation has a rating of 5 - 10 MW and the cost equation for DG was $y=4.50P$. Simulations were performed before and after the renewable generators installed.

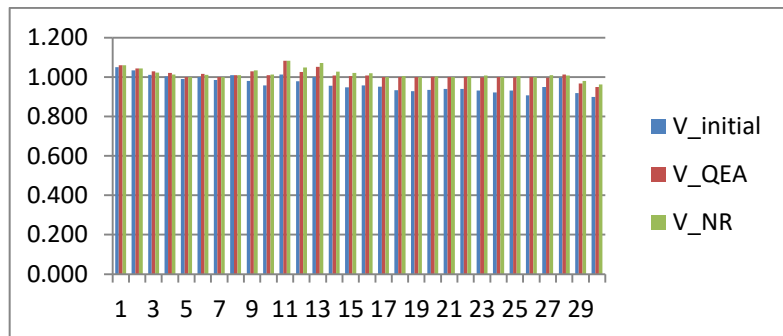

Figure 5. Voltage profile of the buses

Table 2. Simulation result

Bus	Load (MW)	Bus Voltage (pu)	Generation In initial condition (MW)	Bus Voltage ED_QEA with DG (pu)	Generation ED_QEA with DG (MW)	Bus Voltage ED_NR with DG (pu)	Generation ED_NR with DG (MW)
1	0.000	1.050	200	1.060	198.3	1.060	199.90
2	34.440	1.033	80	1.043	80.0	1.043	80.00
3	3.809	1.011	0	1.029	0.0	1.022	0.00

4	12.060	1.003	0	1.021	0.0	1.013	0.00
5	149.500	0.990	50	1.000	50.0	1.000	34.79
6	0.000	1.000	0	1.015	0.0	1.011	0.00
7	36.180	0.986	0	1.000	5.0	1.000	10.00
8	47.610	1.010	35	1.010	35.0	1.010	35.00
9	0.000	0.981	0	1.029	0.0	1.034	0.00
10	9.204	0.957	0	1.010	0.0	1.012	0.00
11	0.000	1.012	30	1.082	30.0	1.082	30.00
12	17.770	0.978	0	1.025	0.0	1.049	0.00
13	0.000	1.000	40	1.051	40.0	1.071	40.00
14	9.839	0.956	0	1.008	0.0	1.027	0.00
15	13.010	0.948	0	1.005	0.0	1.021	0.00
16	5.554	0.958	0	1.007	0.0	1.019	0.00
17	14.280	0.951	0	1.000	5.0	1.000	5.00
18	5.078	0.933	0	0.999	0.0	1.005	0.00
19	15.080	0.928	0	1.000	5.0	1.000	10.00
20	3.491	0.934	0	1.001	0.0	1.002	0.00
21	27.770	0.939	0	1.000	5.3	1.000	5.00
22	0.000	0.940	0	1.001	0.0	1.002	0.00
23	5.078	0.932	0	0.998	0.0	1.007	0.00
24	13.810	0.922	0	1.000	5.0	1.000	10.00
25	0.000	0.932	0	0.998	0.0	1.004	0.00
26	5.554	0.906	0	1.000	5.3	1.000	5.00
27	0.000	0.950	0	0.996	0.0	1.010	0.00
28	0.000	0.997	0	1.013	0.0	1.008	0.00
29	3.809	0.918	0	0.967	0.0	0.980	0.00
30	16.800	0.899	0	0.949	0.0	0.963	0.00
Tot. load (MW)	449.900						
Tot. Gen (MW)		435.000		463.942		464.693	
Losses (MW)				14.042		14.793	
Cost (\$/Hour)				1593.63		1558.90	

By using Newton-Raphson Power Flow, from Table 2, we can see that when the total load of the system is reaching maximum at 449.9 MW, the voltages at bus 30 are below standard (0.899 pu). New generators need to be added in order to sufficiently satisfy power demand and to shoulder line losses and also to increase the voltages of the buses under standard (bus30). Small capacity distributed generators (DGs) can supplement the existing thermal generators in improving voltage profiles of the buses. QEA method is used in combination with power flow for calculating generation cost of the thermal generators and for the placement and sizing of DGs. The typical iteration convergence is in figure 4.

We can see from table 2 that placing DGs of sizes 5, 5, 5, 5.3, 5, 5.3 MW on buses 7, 17, 19, 21, 24 and 26 respectively raises the voltages at some of them, so that the voltage on each bus remains at the level permitted as seen in figure 5. The cheapest generating cost as obtained from the calculation is 1593.63\$/h with losses of 14.042 MW.

In order to confirm that QEA is effective enough in this optimisation, lambda iteration of the Economic Dispatch was performed. In the iteration, DGs are placed on the same buses as the buses obtained from the calculation done using QEA (the buses 7, 17, 19, 21, 24 and 26) and with the DGs capacities of 5-10 MW and at maximum load of 499.9 MW. The resulting generation cost is 1558.90 \$/h with losses of 14.793 MW. The overall system stability is better, where the voltages of all buses are at levels permitted.

4. CONCLUSION

This is a study of Economic Dispatch using Quantum Evolutionary Algorithm (QEA) in Electrical Power System involving Distributed Generators. QEA can be used for the placements, sizing and the calculation of thermal power generation and distributed generation to get the cheapest cost of generation.

ACKNOWLEDGEMENTS

The authors thank the Power System Simulation Laboratory, Department of Electrical Engineering, Institut Teknologi Sepuluh Nopember for all facilities and supports for this research.

REFERENCES

- [1] Joko Pitono, Adi Soeprijanto, and Takashi Hiyama” *Hybrid Optimization of Emission and Economic Dispatch by the Sigmoid Decreasing Inertia Weight Particle Swarm Optimization*”, World Academy of Science, Engineering and Technology 60 2009
- [2] Leandro dos Santos Coelho a,*, Chu-Sheng Lee b, “*Electrical Power and Solving economic load dispatch problems in power systems using chaotic and Gaussian particle swarm optimization approaches*”, Energy Systems 30 (2008) 297–307, ELSIVIER.
- [3] Hossein Shahinzadeh1, Sayed Mohsen Nasr-Azadani2, Nazereh Jannesari3, “*Applications of Particle Swarm Optimization Algorithm to Solving the Economic Load Dispatch of Units in Power Systems with Valve-Point Effects*”, International Journal of Electrical and Computer Engineering (IJECE)
- [4] G.Sreenivasan, Dr. C.H.Saibabu, Dr.S.Sivanagaraju, “*Solution of Dynamic Economic Load Dispatch (DELD) Problem with Valve Point Loading Effects and Ramp Rate Limits Using PSO*”, International Journal of Electrical and Computer Engineering (IJECE) Vol.1, No.1, September 2011, pp. xx~xx ISSN: 2088-8708
- [5] Hadi Saadat, “*Power System Analysis*”, McGraw-Hill, International Editions 1999.
- [6] John G. Vlachogiannis and Kwang Y. Lee, :*Quantum-Inspired Evolutionary Algorithm for Real and Reactive Power Dispatch*”, IEEE TRANSACTIONS ON POWER SYSTEMS, VOL. 23, NO. 4, NOVEMBER 2008.
- [7] John G. Vlachogiannis and Kwang Y. Lee, “*Using Chaotic Quantum Genetic Algorithm Solving Environmental Economic Dispatch of Smart Microgrid Containing Distributed Generation System Problems*”, 2010 International Conference on Power System Technology.
- [8] Júlio Xavier Vianna Neto a, Diego Luis de Andrade Bernert b, Leandro dos Santos Coelho b,*, *Improved quantum-inspired evolutionary algorithm with diversity information applied to economic dispatch problem with prohibited operating zones Energy Conversion and Management* 52 (2011) 8–14, ELSIVIER.
- [9] Gwo-Ching Liao,”*Using Chaotic Quantum Genetic Algorithm Solving Environmental Economic Dispatch of Smart Microgrid Containing Distributed Generation System Problems*”, 2010 International Conference on Power System Technology.
- [10] John G. Vlachogiannis a,*, Jacob Østergaard,”*Reactive power and voltage control based on general quantum genetic algorithms*”, ELSEVIER , Expert Systems with Applications 36 (2009) 6118–6126.
- [11] Han, K.-H., & Kim, J.-H. (2000), “*Genetic quantum algorithm and its application to combinatorial optimization problem*”. Proceedings of Congress on Evolutionary Computation, 1354–1360.