

## Implimentation of Evolutionary Particle Swarm Optimization in Distributed Generation Sizing

J.J. Jamian\*, M.W. Mustafa\*, H. Mokhlis\*\*, M.A. Baharudin\*

\* Faculty of Electrical Engineering, Universiti Teknologi Malaysia

\*\* Faculty of Engineering, University of Malaya

---

### Article Info

#### Article history:

Received Jan 4<sup>th</sup>, 2012

Revised Feb 12<sup>th</sup>, 2012

Accepted Feb 14<sup>th</sup>, 2012

---

#### Keyword:

Resizing

Distributed Generator

Evolutionary Particle Swarm Optimization

Power Loss Reduction

---

### ABSTRACT

The size of Distributed Generation (DG) is crucial in order to reduce the impact of installing a DG in the distribution Network. Without proper connection and sizing of DG, it will cause the power loss to increase and also might cause the voltage in the network to operate beyond the acceptable limit. Therefore, many researchers have given concentration on the formulation optimization technique to regulate the DG's output to compute its optimal size. The distinctions between these techniques were on the ability to acquire the optimal value with hasty computing time for solving the problems. PSO is among the popular optimization methods due to its simplicity and satisfying value. However, the computing time for PSO is dependant to the problem that needs to be solved. In this paper, the concept of Evolutionary Particle Swarm Optimization (EPSO) method is implemented in sizing the DG units. By substituting the concept of Evolutionary Programming (EP) in some part of Particle Swarm Optimization (PSO) algorithm process, it will make the process of convergence become faster. The algorithm has been tested in 33bus distribution system with 3 units of DG that operate in PV mode. Its performance was compared with the performance when using the traditional PSO and without using any optimization method. In terms of power loss reduction and voltage profile, the EPSO can give similar performance as PSO. Moreover, the EPSO requires less number of iteration and computing time to converge. Thus, it can be said that the EPSO is superior in term of speed, while maintaining the same performance.

*Copyright © 2012 Insitute of Advanced Engineering and Science.  
All rights reserved.*

---

### Corresponding Author:

Jasrul Jamani Jamian,

Departement of Power System Engineering,

Faculty of Electrical Engineering,

Universiti Teknologi Malaysia, 81310 UTM Johor Bahru, Johor, Malaysia.

Email: [jasrul@fke.utm.my](mailto:jasrul@fke.utm.my)

---

## 1. INTRODUCTION

The connection of Distributed Generation (DG) at the consumer side has given a lot of opportunities for the network to reduce the existing power losses. With the implementation of DG units, the distribution system no longer have a single supply system, which is from the transmission-distribution substation, but there will be multiple sources power in the network. Thus, the DG units will supply to some of the local load while the other loads will still get the power supply from the main source. However, the incompatibleness of the size and location of the DG will give an opposite effect to the distribution network such as power loss increase, voltage operating beyond the limit and others [1-5]. Therefore, many researchers have conducted studies to obtain the appropriate location and size for the DG either for a single DG unit [2],[4] or for multiple DG units [6-7]. The optimization techniques such as Genetic Algorithm (GA), Particle Swarm Optimization (PSO), Evolutionary Programming (EP), Ant Colony Optimization (ACO) and other heuristic

methods are usually used in finding the optimal size of DG. With these optimization methods, it could help the power system planner to compute the optimal capacity of DG size for the network.

The analysis in [8] is one of the most recent studies on optimal placement and sizing of DG units in the distribution system. The author used combination of two heuristic optimization methods which are Genetic Algorithm and Immune System in order to maximize the benefit of DG. Since the size of DG is directly related to the power losses and the cost of reinforcement, thus the authors aim to minimize both factors in order to achieve the optimal DG output in the system. The authors have compared the method with other optimization methods which are GA, PSO, Immune Algorithm (IA), Ordinal Optimization (OO) and GA-OPF. However, the locations of DGs are diverse for each optimization methods and can cause the optimal power losses values to be different. Furthermore, the implementation of DG optimal sizing is not only restricted to distribution network. Some researchers also focus on optimizing the large scale of DG that is connected to the mesh transmission network [9]. Since the DG is built with a large capacity, the characteristic of the DG is most likely the same as traditional power generator. In this case study, the authors implement a simple conventional iteration in order to optimize the size of DG to achieve the same objectives as in [8] which are to lower down both cost and losses in the network. Although the analysis for DG connected at transmission network can be made, but the implementation of this DG is cumbersome due to the capacity of DG must be large enough. The objective of DG sizing is not only limited to the reduction of power loss and lowering the cost of generation, but the sizing of DG can also be used to minimize the total harmonic distortion (THD) in the network [10], lowering the short circuit level that represents the protective device in the network [11] and many more.

In this paper, the concept of hybrid optimization between EP and the PSO which has introduced in [12] is used to analyze the performance of the algorithm for DG sizing which known as Evolutionary PSO (EPSO). The performance of proposed methods will be compared to traditional PSO in term of reduction of power losses value, voltage profile, computing time and others when the DG connected at the distribution level. The detail of the algorithm will be discussed in Section 2. Section 3 shows the simulation results between the performance of traditional PSO and EPSO in term of power loss and voltage profile for 33 bus radial distribution systems. Last but not least, Section 4 presents the conclusion of the study.

## 2. RESEARCH METHOD: OPTIMIZATION APPROACHED

The PSO is one of the heuristic methods used by researchers to solve any optimization problem. The main idea of the PSO is based on the food searching behavior (foraging) of birds or fish. The birds or fish will move to the food in certain speed and position. Their movement will depend on their own experience (local best) and other 'friends' in the group (global best). The finding process of local best and global best that are computed in every iteration gives the potential to the PSO to reach the most optimal solution. Thus, many researchers tend to combine or hybrid the PSO with other optimization methods such as artificial Neural Network (ANN), Genetic Algorithm (GA) or (Evolutionary Programming) EP or other heuristic methods. The combination/hybridization process between PSO and other heuristic methods has been summarized in [13-15].

### 2.1. Basic Machinery of Particle Swarm Optimization

In this subsection, the process and the machinery of the PSO will be discussed in depth. The summary of traditional PSO is as follows.

Step 1: The population of  $N$  particles is initialized with random positions,  $x$  and the velocity,  $v$  of each particle is set to zero. Each particle can have  $d$  number of variables.

Step 2: The objective function is evaluated with all particles in order to find the objective value. The particles generated will be tested for it fitness to the objective. If the value of a particle and the objective value obtained from that particle are within the constraints of the system, that particle will be accepted. Meanwhile if the particle itself or the objective value obtained from that particle is out of the range of the system's constraints, new particle will be generated and this step will be repeated for the number of particles which are out of the boundary. The local best,  $P_{best}$ , is set as the current position and objective value of the particle, and the global best,  $G_{best}$  and its objective value is set as the best initial particle.

Step 3: The new velocity,  $v_{i+1}$  and the new position,  $x_{i+1}$ , is calculated using equations (1) and (2) and the values of the current  $G_{best}$  and  $P_{best}$ .

Step 4: Evaluate the objective values of all particles using the new position.

- Step 5: The objective value of each particle is compared with its previous objective value. If the new value is better than the previous value, then update the  $P_{best}$  and its objective value with the new position and objective value. If not, maintain the previous values.
- Step 6: Determine the best particle of the whole updated population with the  $G_{best}$ . If the objective value is better than the objective value of  $G_{best}$ , then update  $G_{best}$  and its objective value with the position and objective value of the new best particle. If not, maintain the previous  $G_{best}$ .
- Step 7: If the stopping criterion is met, then output  $G_{best}$  and its objective value; otherwise, repeat step three.

$$v_{i+1} = \omega V_i + c_1 r_1 (P_{best} - x_i) + c_2 r_2 (G_{best} - x_i) \quad (1)$$

$$x_{i+1} = v_{i+1} + x_i \quad (2)$$

A calculation example for one level of iteration is as shown in Table 1.

Table 1. The Example of PSO Calculation Concept to Find the Minimum Point

	set 1	set 2	$P_{best}$	$G_{best}$
	Fitness_1 <sup>1</sup> = 6.845	Fitness_1 <sup>2</sup> = 6.458	Element (6.458)	
	Fitness_2 <sup>1</sup> = 7.214	Fitness_2 <sup>2</sup> = 7.421	Element (7.214)	
	Fitness_3 <sup>1</sup> = 3.125	Fitness_3 <sup>2</sup> = 3.013	Element (3.013)	
	Fitness_4 <sup>1</sup> = 6.127	Fitness_4 <sup>2</sup> = 6.478	Element (6.127)	
	Fitness_5 <sup>1</sup> = 4.025	Fitness_5 <sup>2</sup> = 4.125	Element (4.025)	
	Fitness_6 <sup>1</sup> = 6.389	Fitness_6 <sup>2</sup> = 6.446	Element (6.389)	Element (3.013)
$G_{best}$	3.125	3.013		

Set 1 is a set of old positions and set 2 is a set of new positions. The  $P_{best}$  set is selected by comparing the best value between the fitness values achieved by set 1 and set 2. For example, the set 1 and set 2 fitness values for the 4<sup>th</sup> element are 6.127 and 6.478 respectively. Assuming that the process of optimization is to obtain the minimum value, the element for the set 1 (Element (Fitness\_4<sup>1</sup>)) is chosen as a  $P_{best}$  value. Next, for the new  $G_{best}$ , the  $G_{best}$  for set 1 and set 2 will be compared and the smallest value between both sets is preferred as the new  $G_{best}$ . Hence, in this example, the  $G_{best}$  for set 1 is smaller than the  $G_{best}$  for set 2. Thus, the new  $G_{best}$  value was the element for Fitness\_3<sup>2</sup>.

Up till this point, the traditional PSO method has been discussed. EPSO is similar to PSO in many of the steps. This statement is obvious, because EPSO itself is based on PSO. However, their similarities stop at the steps 5 and 6 where the new  $P_{best}$  and new  $G_{best}$  are determined. In the next subsection, EPSO will be discussed in greater detail.

## 2.2. Evolutionary Particle Swarm Optimization's Machinery

In this subsection, the process and the machinery of the EPSO will be discussed in detail. In EPSO, the process is similar as PSO from step 1 until step 4. The concept of EP is integrated in steps 5 and 6 (of the previous subsection), where the tournament selection process is done. For the discussion on EPSO, refer Figure 1.

After obtaining the new position,  $x_{i+1}$ , the new fitness value,  $y_{i+1}$ , is calculated using the values of  $x_{i+1}$ . Subsequently, the set of new positions,  $x_{i+1}$ , and the old ones,  $x_i$ , will be combined and contested in a tournament with a number of positions other than itself according to the contestants' percentage settings. For example, if 20 positions are selected, and the percentage is set to 20 percent, then all positions will be challenged by four other contestants randomly, and each position will be weighted by the number of wins it obtains. A position gains a win when its fitness is better than its contender. This tournament is the part which is adapted from EP and different from the traditional PSO.

After the tournament, the positions will be sorted out in a descending fashion, starting with the highest wins down to the lowest wins.  $N$  number of positions with the best score will be selected from the result as the survival positions, which will be used for the next iteration. These positions will also be used as the new  $P_{best}$  and the position with the highest score will be used as the new  $G_{best}$ . Next, the new position set will be tested for convergence. If convergence is not achieved, the process will be repeated by calculating a newer velocity and position using equations (1) and (2) based on the new  $P_{best}$  and  $G_{best}$ . If convergence is achieved, then the optimization process is terminated.

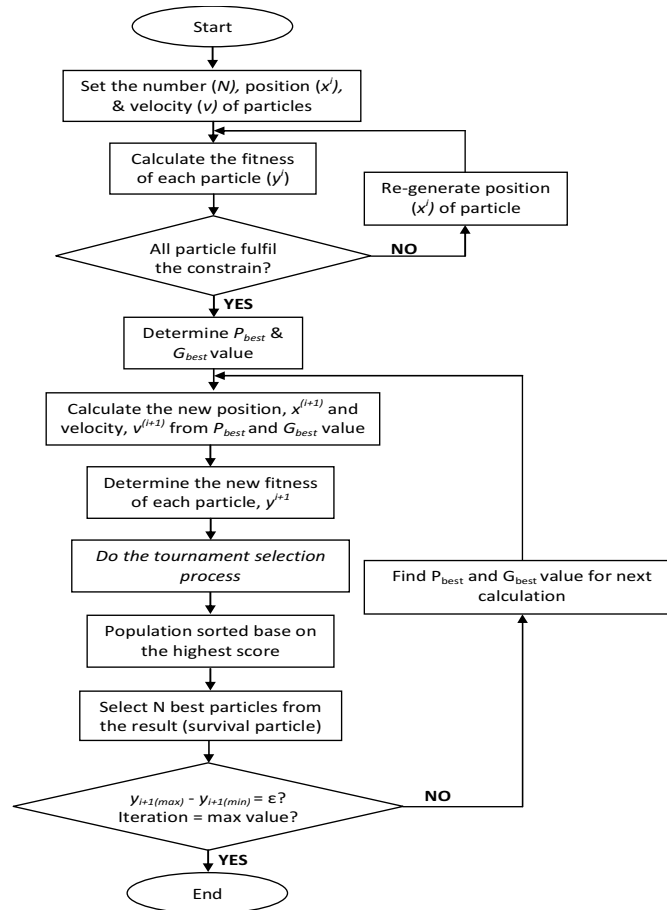

Figure 1. The flow chart for EPSO algorithm

An example of how to calculate a level of iteration is as shown in Table 2 where set 1 is the oldest position set, and set 2 is the newest position set calculated using equations (1) and (2).

Table 2. The Example of EPSO Calculating Concept to Find the Minimum Point

set 1	set 2	set1+set2	Competition: Win	Selection ( $P_{best}$ )	$G_{best}$
Fitness_1 <sup>1</sup> = 6.845	Fitness_1 <sup>2</sup> = 6.458	Fitness_1 <sup>1</sup> = 6.845	1	Element (3.125)	Element (3.013)
Fitness_2 <sup>1</sup> = 7.214	Fitness_2 <sup>2</sup> = 7.421	Fitness_2 <sup>1</sup> = 7.214	0	Element (3.013)	
Fitness_3 <sup>1</sup> = 3.125	Fitness_3 <sup>2</sup> = 3.013	Fitness_3 <sup>1</sup> = 3.125	2	Element (4.125)	
Fitness_4 <sup>1</sup> = 6.127	Fitness_4 <sup>2</sup> = 6.478	Fitness_4 <sup>1</sup> = 6.127	0	Element (6.845)	
Fitness_5 <sup>1</sup> = 4.025	Fitness_5 <sup>2</sup> = 4.125	Fitness_5 <sup>1</sup> = 4.025	1	Element (3.013)	
Fitness_6 <sup>1</sup> = 6.389	Fitness_6 <sup>2</sup> = 6.446	Fitness_6 <sup>1</sup> = 6.389	1	Element (4.125)	
		Fitness_1 <sup>2</sup> = 6.458	0		
		Fitness_2 <sup>2</sup> = 7.421	0		
		Fitness_3 <sup>2</sup> = 3.013	2		
		Fitness_4 <sup>2</sup> = 6.478	0		
		Fitness_5 <sup>2</sup> = 4.125	2		
		Fitness_6 <sup>2</sup> = 6.446	0		

The third column shows the combination of set 1 and set 2. In column four, the scores achieved by each position is shown based on the number of wins in the tournament. In this example, each set consists of 6 positions and the challenger percentage is set to 20 percent so that each position will compete with two other competitors. That is why in the fourth column, the highest achievable score is two. In the fifth column, six positions with the best fitness will be chosen as the  $P_{best}$  and in the last column the element or position with the best fitness among the  $P_{best}$  will be selected as  $G_{best}$ . From the results, only the survival element during the competition process will be maintained for the next iteration while the other are terminated. This process make the EPSO could achieved the optimal value faster than traditional PSO.

### 3. RESULTS AND DISCUSSION

The 33 bus radial distribution system is used for the analysis on the performance of EPSO versus PSO as shown in Figure 2.

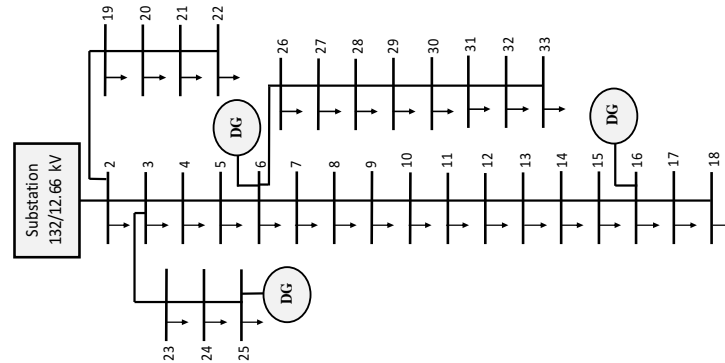

Figure 2. 33 radial distribution system with existing of DG operated at PV mode

The line and load data for the system can be gained in [16]. There are 3 units of DG which are present in the network, at buses 6, 16 and 25 and operating in P-V bus mode. In this simulation, the initial capacities of the DG units are 2.4878 MW, 0.4970 MW and 0.3556 MW whilst the power loss in the network is 23.1049 kW. The technique to get the location and capacity of DGs is obtained using the same approach as in [17]. In the analysis, the authors used the mathematical approach for determining the location and size of DG in the distribution network before improved it using PSO method. However, all the DGs are operated in the PQ mode. Therefore, the DGs location in [17] are different compared to the location that can be obtained in Fig. 2 due to the effect of PQ and PV mode in finding the power loss saving. Besides that, by implemented DG operated at PV mode, the power losses after the optimal location and sizing is improved as shown in Table 3.

Table 3. Comparison the performance optimal location and size of DGs without Optimization method

No		DG operate in PQ mode [16] Without Optimization method	DG operate in PV mode Without Optimization method
1	Location of DGs	6, 15, 25, 32	6, 16, 25
2	No. of DG units	4	3
3	Total DG size (MW)	3.0884	3.3404
4	Total Power Losses (kW) (after DGs placement)	66.5892	23.1049

#### 3.1. Performance of PSO and EPSO in Radial Distribution System

In the power system analysis, the size of DGs are becoming the controllable parameter or “particles” in both optimization methods and the total power losses is the “fitness” or the minimum value that need to be achieved. By randomizing and updating the “particles” using PSO and EPSO methods (as discussed in sections 2.1 and 2.2), the power output of DGs is as shown in Table 4. It can be seen that the PSO and EPSO give the same performance in term of DG size and the total power losses. The DGs that operated at buses 6, 16 and 25 is running at 1.7004 MW, 0.7740 MW and 0.53 MW respectively in order to reduce the power losses from 23.1049 kW to 17.1721 kW. Thus, by resizing all these 3 units of DG, the total power losses can be reduced up to 5.9328kW which is equal to 25.68 percent.

However, by comparing the PSO and EPSO methods, the EPSO algorithm gives a better result in terms of processing time to reach the optimal size of DG. For the traditional PSO, it requires 79 iterations before it can converge. On the other hand, EPSO which implements the competition concept from the EP requires only 56 number of iteration before it converges. The difference in number of iteration between EPSO and PSO is due to the concept used in EPSO which only maintains survival or successful particles. These survival particles are the particles among the population set that will give the lower fitness value in the optimization process (for minimum optimization cases). Thus, it will make the process of convergence becomes faster. As a result, EPSO gives superior results compared to PSO in sizing of DG to minimize the power losses in the network.

Table 4. Comparison the performance of EPSO and PSO with initial condition

33 bus Distribution System	Location (bus)	Without Optimization Technique	PSO	EPSO
DG 1 (MW)	6	2.4878	1.7004	1.7004
DG 2 (MW)	25	0.4970	0.7740	0.7740
DG 3 ( MW)	16	0.3556	0.5300	0.5300
Total DG Capacity (MW)		3.9325	3.0044	3.0044
Total Power Loss (kW)		23.1049	17.1721	17.1721
Power losses Reduction (%)		-	25.68	25.68
Iteration (average)		-	79 <sup>th</sup>	56 <sup>th</sup>
Computation Time (s) (average)		-	93.2874	71.2743

Figures 3 and 4 shows the total DG capacities that installed with the value of power loss and the comparison of voltage profile after the optimization take place in the analysis respectively. Since the performance in finding optimal DG capacity for PSO and EPSO are same, both optimization method have the lowest value of total DG capacity and lowest total power loss compared to the initial stage (without the optimization). From the results (Figure 4), the extra capacity of DG in the network does not guarantee that the system will have lower power losses value. It proves that the DG sizing play an important role in determining the power losses value in the network. By having the optimal size of DG, it will give better reduction in total power losses value while fulfilling all the other constraints in the network. Thus, it is very important to have the optimal DG capacity rather than additional DG capacity that can increase the power losses.

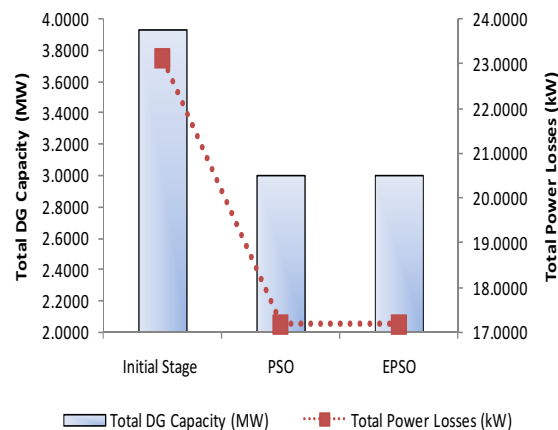

Figure 3. Total DG Generated Power vs Total Power Loss in 33 bus distribution system

The voltage profile in the network is quite similar for all DGs connected cases either with or without optimization as shown in Figure 4. Since the generation capacity has been reduced during the optimization process either for PSO or EPSO cases, some of the buses experience the voltage reduction while the others have the same voltage value especially for the busses which do not have DG connection in the feeder. However, the voltage reductions on some buses still fulfill the voltage constraint that has been set in the system which is from 0.95p.u to 1.05p.u.

Figure 5 shows the detail on the result of voltage reduction that occurs due to the optimization. The highest voltage reduction that occurred in the network is only near to 0.12 percent or equal to 0.0012p.u which is for bus 9 and followed by bus 5 which is near to 0.095 percent or 0.00095p.u. Besides that, only one bus will experiences the voltage increment which is bus 13. However, these voltage changes that occur in the network is very small and can be ignored. It can be concluded that the adjustment of DG capacity in the network does not give significant impact to the bus voltage, but only on the power loss. Therefore, REPSO gives a faster solution to optimize the DG capacity with minimum power loss and without affecting the voltage profile in the network.

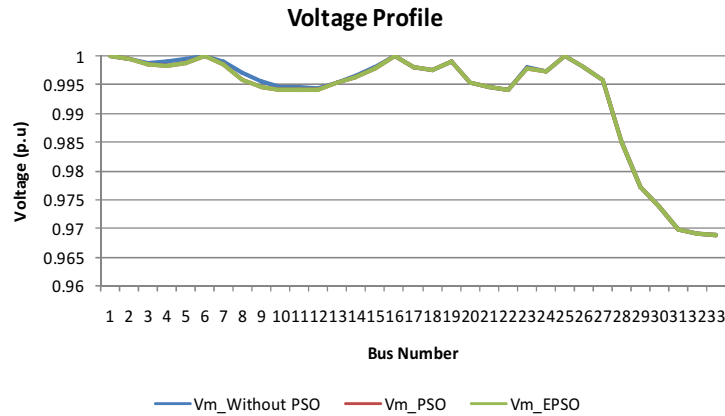

Figure 4. Voltage profile for 33 bus distribution system

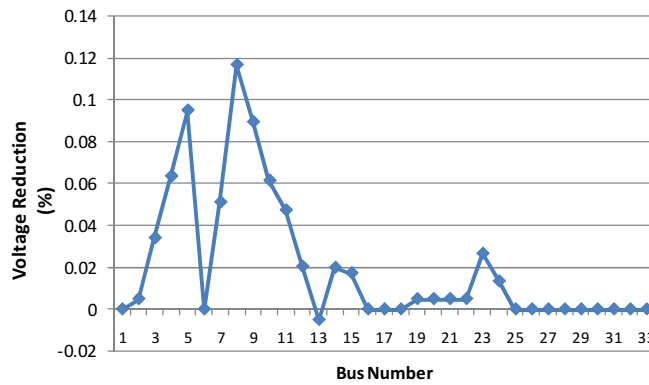

Figure 5. The Percentage of Voltage Changes after Optimization Process

Since the performance to find the optimal sizing and reduce the power losses in the distribution network between PSO and EPSO is similar, the improvement given by these two types of optimization can be summarized as in Table 5. It can be clearly seen that the percentage of total voltage drop in the network due to optimization process is too small which is approximately 0.675 percent while the savings that can be achieved from the optimization process is very high which is near to 50 percent. The savings consist the reduction on power loss ( $\approx 26$  percent) in the network and the total DG reduction ( $\approx 24$  percent). As a result, EPSO can give a faster solution compared to traditional PSO and also give superior performance if compared with the solution without the optimization method.

Table 5. Summary Performance of Optimization vs Without Optimization Method

No	Summary of Performance	Percentage (%)
1	Total Voltage Drop	0.674908
2	Total Power Losses Reduction	25.67767
3	Total DG power Reduction	23.60076

### 3.2. Effect of Using Different Number of Particle for the Optimization Process.

The result for optimal sizing of DG in section 3.1 is obtained using 20 particles. Many researchers have suggested the number of particle for the PSO cannot be too large or too small. If the number of particle is too large, it might cause the processing time to be too long whilst by using too little particles; it can cause the results of the optimization to be trapped in the local value and will not achieve the global value. Thus, in this section, the number of particle for PSO and EPSO will be varied in order to see the impact to the performance in the distribution network.

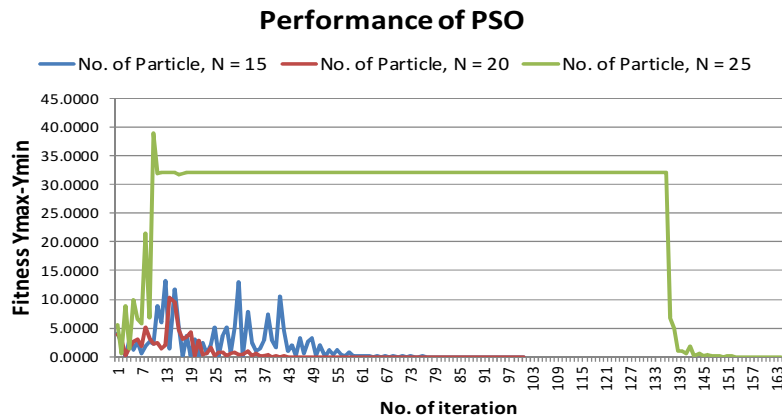

Figure 6. The performance of PSO by varying the number of particle in the analysis.

Figure 6 shows the performance of PSO when the population of particles is configured as 15, 20 and 25 respectively. The performance of the algorithm is measure based on the difference between maximum and minimum fitness value among the particles for each level of iteration and the speed for them to reach the same optimal value. From the figure, when the population of particle is 25, it takes many iteration steps to reach the optimal value compared to when the number of population is 15 or 20. There is a gap where the different fitness value among the particle is constant before optimal point is reached. This is the weakness of PSO if the number of population chosen is too large. However, when the population size of PSO is 15, it will also take more iteration to reach the optimal point. It is due to the possibility that the PSO has reached the local optimal point before getting the global optimal value along the searching process. Thus, it can be said that the number of population of 20 particles is an ideal value for this case study.

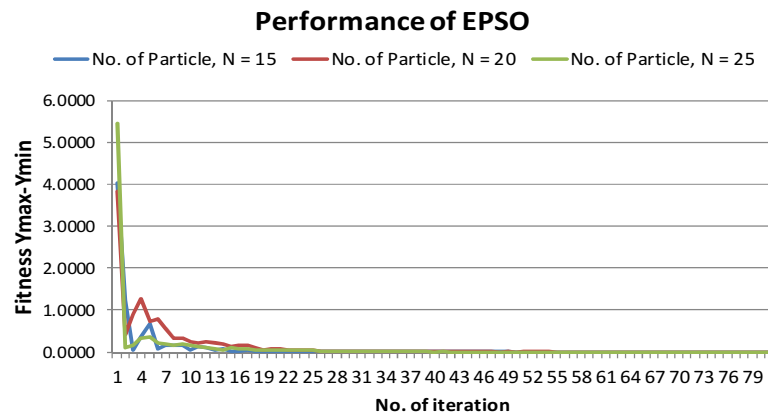

Figure 7. The performance of EPSO by varying the number of particle in the analysis.

On the other hand, EPSO will not face the trapping condition as PSO does when the number of population is 25 as shown in Figure 7. From the figure, regardless the number of population for EPSO, it will give a faster convergence value compared to the PSO. The competition and selection concept in EPSO can guarantee that the faster solution can be achieved. Besides that, the performance of EPSO also looks more stable where the fitness value is not varying too much as PSO does. Table 5 shows the summary between the performance of PSO and EPSO when the number of particle is changed. The EPSO give the faster solution regardless of the number of population compared to PSO. Thus, the percentage of improvement in the iteration process that has been done by EPSO is shown in Figure 8.

Table 5. Comparison the performance of PSO and EPSO by varying the size of population

Number of Particles	PSO	EPSO
	(no. of iteration)	(no. of iteration)
N = 15	90	75
N = 20	79	56
N = 25	164	54



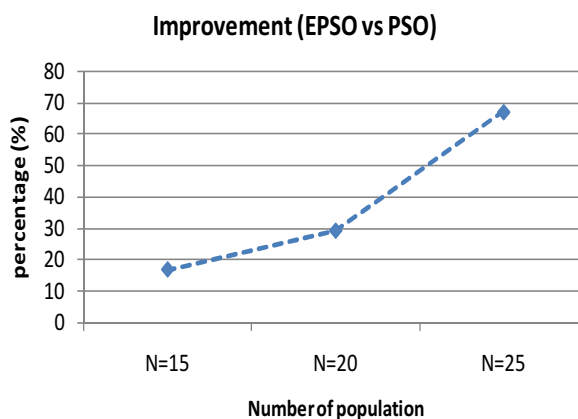

Figure 8. The improvement in number of iteration by EPSO

#### 4. CONCLUSION

The power losses in the distribution network can be reduced by having the optimal size of DG. Since EPSO and PSO can give the same performance in finding the optimal size of DG, it shows that EPSO can give superior results by having less iteration and shorter computation time in solving the optimization problem.

Besides that, PSO also has the possibility of being trapped at certain value after certain amount of iteration has been done. Thus, the concept of competition and selection in EPSO can avoid this problem by selecting the survival particles to remain in the next iteration. Therefore, EPSO's performance is superior than traditional PSO and can be used to solve the power system optimization problem.

#### REFERENCES

- [1] Abu-Mouti, F.S. El-Hawary, M.E., "Heuristic curve-fitted technique for distributed generation optimisation in radial distribution feeder systems", *Generation, Transmission & Distribution, IET*, vol.5, no.2, February 2011, pp.172-180.
- [2] T. Gozel, M. H. Hocaoglu, "An Analytical Method for the Sizing and Siting of Distribution Generators in Radial System", *International Journal of Electric Power System Research*, Vol. 79, No. 6, June 2009, pp. 912-918.
- [3] M.F.Kotb, K.M.Sheb, M. El Khazenda, A. El Hussein, "Genetic Algorithm for Optimum Siting and Sizing of Distributed Generation", *The 10th MEPCON International Middle East Power Systems Conference*, December 19-21, 2010.
- [4] Alemi, P., Gharehpetian, G.B., "DG allocation using an analytical method to minimize loss and to improve voltage security," *Power and Energy Conference, 2008, PECon 2008. IEEE 2nd International*, vol., no., 1-3 Dec. 2008, pp.1575-1580.
- [5] Zhipeng Liu; Fushuan Wen; Ledwich, G.; Xingquan Ji; , "Optimal sitting and sizing of distributed generators based on a modified primal-dual interior point algorithm", *Electric Utility Deregulation and Restructuring and Power Technologies (DRPT), 2011 4th International Conference on*, vol., no., 6-9 July 2011, pp.1360-1365.
- [6] Hedayati, H., Nabaviniaki, S.A., Akbarimajd, A., "A Method for Placement of DG Units in Distribution Networks", *Power Delivery, IEEE Transactions on*, vol.23, no.3, July 2008, pp.1620-1628.
- [7] Gareth P. Harrison, Antonio Piccolo, Pierluigi Siano, A. Robin Wallace, "Distributed Generation Capacity Evaluation Using Combined Genetic Algorithm and OPF", *International Journal of Emerging Electric Power Systems*, vol. 8, Iss. 2, Art 7, 2007, pp. 1 – 13.
- [8] A. Soroudi and M. Ehsan, "Efficient immune-GA method for DNOs in sizing and placement of distributed generation units", *European Transactions on Electrical Power*, vol. 21, no. 3, April 2011, pp. 1361-1375.
- [9] S. Ghosh, S. P. Ghoshal, and S. Ghosh, "Optimal sizing and placement of distributed generation in a network system", *International Journal of Electrical Power & Energy Systems*, vol. 32, no. 8, Oct 2010, pp. 849-856.
- [10] A. Khanjanzadeh, M. Sedighzadeh, A. Rezazadeh, and A. Pahlavanhoseini, "Using Clonal Selection Algorithm for Siting and Sizing of Distributed Generation in Distribution Network to Improve Voltage Profile and Reduce THD and Losses", *International Review of Electrical Engineering-Iree*, vol. 6, no. 3, May 2011, pp. 1325-1331.
- [11] M. M. Elnashar, R. El Shatshat, and M. M. A. Salama, "Optimum siting and sizing of a large distributed generator in a mesh connected system", *Electric Power Systems Research*, vol. 80, no. 6, June 2010, pp. 690-697.
- [12] Angeline, P.J., "Using selection to improve particle swarm optimization", *Evolutionary Computation Proceedings, 1998. IEEE World Congress on Computational Intelligence., The 1998 IEEE International Conference on*, vol., no., 4-9, May 1998, pp.84-89.

- [13] Del Valle, Y., Venayagamoorthy, G.K., Mohagheghi, S., Hernandez, J.-C., Harley, R.G., "Particle Swarm Optimization: Basic Concepts, Variants and Applications in Power Systems", *Evolutionary Computation, IEEE Transactions on*, vol.12, no.2, April 2008, pp.171-195.
- [14] A. Banks, J.Vincent, and C.Anyakoha, "A review of particle swarm optimization. Part I: Background and development", *Nat. Comput.* 6(4), 2007, pp. 467-484.
- [15] A. Banks, J. Vincent, C. Anyakoha, "A review of particle swarm optimization. Part II: Hybridisation, combinatorial, multicriteria and constrained optimization, and indicative applications", *Nat. Comput.* 7(1), 2008, pp. 109-124.
- [16] J. J. Jamian, H. Musa, M. W. Mustafa, H. Mokhlis and S. S. Adamu, "Combined Voltage Stability Index for Charging Station Effect on Distribution Network", *International Review of Electrical Engineering-IREE*, submitted for publication.
- [17] M.P. Lalitha, V.C. Veera Reddy, V. Usha, "Optimal DG placement for Minimum Real Power Loss in Radial Distribution System Using PSO", *Journal of Theoretical and Applied Information Technology*, vol 13, no. 2, 2005, pp. 107-116

## BIBLIOGRAPHY OF AUTHORS

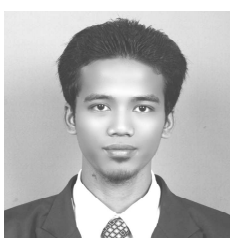

Jasrul Jamani Jamian obtained his B. Eng. (Hons) in Electrical Engineering in 2008 and M. Eng. Electrical (Power) in 2010 from Universiti Teknologi Malaysia (UTM), Johor Bahru, Malaysia and he is currently pursuing his Ph.D. degree. His current research interests include smart grid system, power system stability, renewable energy application and their control method. He is a student member of IEEE.

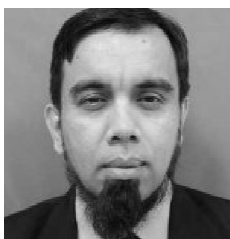

Mohd Wazir Mustafa received his B. Eng Degree (1988), M. Sc. (1993) and PhD (1997) from university of Strathclyde. He is currently an Associate Professor and Deputy Dean Graduate Studies and Research at Faculty of Electrical Engineering, Universiti Teknologi Malaysia (UTM), Johor Bahru, Malaysia. He research interest includes power system stability, FACTS and power system distribution automation. He is a member of IEEE.



Hazlie Mokhlis received his B. Eng in Electrical Engineering in 1999 and M. Eng. Sc in 2002 from University of Malaya, Malaysia. His obtained PhD degree from the University of Manchester, UK in 2009. Currently he is a Lecturer in the Department of Electrical Engineering, University of Malaya. His main research interest is in distribution automation area and power system protection. He is a member of IEEE.



Muhammad Ariff Baharudin received his B. Eng. in Mechatronics and M. Eng. in Electronics and Telecommunications from Universiti Teknologi Malaysia in 2008 and 2010 respectively. He is currently pursuing his Ph.D in Shibaura Institute of Technology, Japan. His research interests include Smart Grid, network optimization and network communication protocols.