

Study of Wind Turbine based SEIG under Balanced/Unbalanced Loads and Excitation

K. Trinadha*, A. Kumar**, K. S. Sandhu***

* Department of Electrical Engineering, National Institute of Technology, Kurukshetra

** Department of Electrical Engineering, National Institute of Technology, Kurukshetra

*** Department of Electrical Engineering, National Institute of Technology, Kurukshetra

Article Info

Article history:

Received Mar 11th, 2012

Revised May 10th, 2012

Accepted May 22nd, 2012

Keyword:

Self excited induction generator

Wind turbine

R-L and R-C loads

Balanced/unbalanced excitation

Balanced/unbalanced loads

ABSTRACT (10 PT)

This paper presents the performance of a stand-alone self-excited induction generator (SEIG) driven by fixed pitch wind turbine. The main objective of the paper is: (i) dynamic study of SEIG under balanced R-L/R-C loads (ii) dynamic study of SEIG under balanced and unbalanced excitation, (iii) Fixed pitch wind turbine model has been considered for driving induction generator. An approach based on dynamic equations of an isolated SEIG under balanced/unbalanced conditions of loads is employed to study the behaviour of the system. The SEIG model with balanced/un-balanced load and excitation has been simulated using MATLAB/SIMULINK.

Copyright © 2012 Institute of Advanced Engineering and Science.

All rights reserved.

Corresponding Author:

A. Kumar,

Department of Electrical Engineering,

National Institute of Technology, Kurukshetra,

Haryana, India.

Email: ashwani.k.sharma@nitkkr.ac.in

1. INTRODUCTION

Renewable energy integration in the existing power systems is the demand in future due to the environmental concerns with conventional power plants. There is emphasis on the generation of power from the renewable sources. In this context, induction generator is becoming popular for power generation with non-conventional energy sources [1]. Self excitation process in induction generators makes the machine for applications in isolated power systems [2]. Various models have been proposed for steady state and transient analysis of self excited induction generator (SEIG) [3-17]. The d-q reference frame model, impedance based model, admittance based model, operational circuit based model, and power equations based models are frequently used for analysis of SEIG [3-17]. The overview of self excited induction generator issues has been provided in [19]. The transient /dynamic analysis of SEIG is reported in [10, 20-22]. The literature has also been reported by many researchers on wind driven self excited induction generator in [24-30]. State space model of self excited induction generator has been presented in [31-33]. A. Kishore *et al.* [32] proposed a generalized state-space dynamic modeling of a three phase SEIG developed using d-q variables in stationary reference frame for transient analysis.

The state space approach has been proposed for representation of transient operation of SEIG. The d-q axes stator-rotor current are the functions of machine parameters. The solution of such equation has been obtained assuming all the non linear parameters. The modelling of excitation system under balanced/un-balanced conditions has been developed in terms of d-q reference. Different constraints such as variation of excitation, wind speed and load have been taken into account and accordingly the effect on generated voltage and current has been analyzed. The effect of excitation capacitance on generated voltage has been analyzed [33]. Performance of wind turbine based SEIG with resistive load and balanced and unbalanced excitation was presented in [34].

In this paper work, an attempt has been made for an analysis of fixed pitch based SEIG and its dynamic behavior has been analyzed under R-L inductive load with balanced and unbalanced excitation conditions. The residual magnetism in the machine is taken into account in simulation process as it is necessarily required for the generator to self excite. Initial voltage in the capacitor is considered as 2 volts for build-up of voltage for excitation of SEIG. The simulations have been carried out developing model in MATLAB/SIMULINK [35]. The paper has been organized in different sections: section III describes SEIG mathematical model, section IV describes SIMULINK model of SEIG with load. In section V, results have been obtained for two cases of excitation under balanced and unbalanced condition with balanced inductive load.

2. SEIG MATHEMATICAL MODEL

The d-q axes equivalent circuit of a (SEIG) supplying an inductive load is shown in Fig. 1. A classical matrix formulation using d-q axes model is used to represent the dynamics of conventional induction machine operating as a generator and is given in (14). Using this matrix representation, we can obtain the instantaneous voltages and currents during the self-excitation process, as well as during load variations.

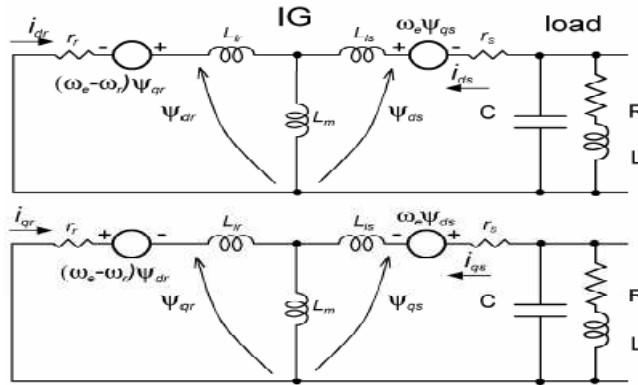

Figure1. d-q axes equivalent circuit of SEIG

The complete dynamic model is represented by the set of eight differential equations corresponding to variables $i_{ds}, i_{qs}, i_{dr}, i_{qr}, V_{ld}, V_{lq}$ as shown in equation (18) is the generalized state space representation of a SEIG model. That is in the form of classical state-space equation.

The dynamic model of the three-phase squirrel cage induction generator is developed by using stationary d-q axes reference frame and the relevant volt-ampere equations are as described as [12]:

$$[V] = [R] [i] + [L] p[i] + w_r[G] [i] \tag{1}$$

From which, the current derivative can be expressed as:

$$p[i] = [L]^{-1} \{ [V] - [R] [i] - w_r[G] [i] \}$$

$$p[i] = - [L]^{-1} \{ [R] [i] + w_r[G] [i] - [V] \} \tag{2}$$

where $[V], [i], [R], [L]$ and $[G]$ defined below:

$$[V] = [V_{ds} \ V_{qs} \ V_{dr} \ V_{qr}]^T, [i] = [i_{ds} \ i_{qs} \ i_{dr} \ i_{qr}]^T, [R] = \text{diag}[R_s \ R_s \ R_r \ R_r],$$

$$L = \begin{bmatrix} L_s & 0 & L_m & 0 \\ 0 & L_s & 0 & L_m \\ L_m & 0 & L_r & 0 \\ 0 & L_m & 0 & L_r \end{bmatrix}$$

$$G = \begin{bmatrix} 0 & 0 & 0 & 0 \\ 0 & 0 & 0 & 0 \\ 0 & L_m & 0 & L_r \\ -L_m & 0 & -L_r & 0 \end{bmatrix}$$

2.1. Load and Capacitor Modeling

Load: Here the modeling of load has been developed in terms of d-q reference frame under balanced conditions. The load currents in terms of their respective voltages have been discussed below:

2.1.1. Balanced RL-Load:

$$i_{ld} = \int ((1/L)V_{ld} - (R/L)i_{ld}), i_{lq} = \int ((1/L)V_{lq} - (R/L)i_{lq}) \tag{3}$$

Balanced R-C load:

$$I_{ld} = C_L \rho(V_{ds} - Ri_{ld}), I_{lq} = C_L \rho(V_{ds} - Ri_{lq}) \tag{4}$$

Figure 2 and 3 show the SIMLINK model of the balanced loads.

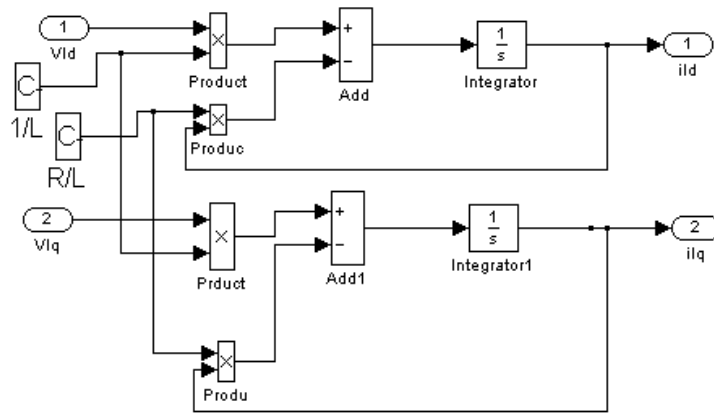

Figure 2. Block model of balanced RL-load

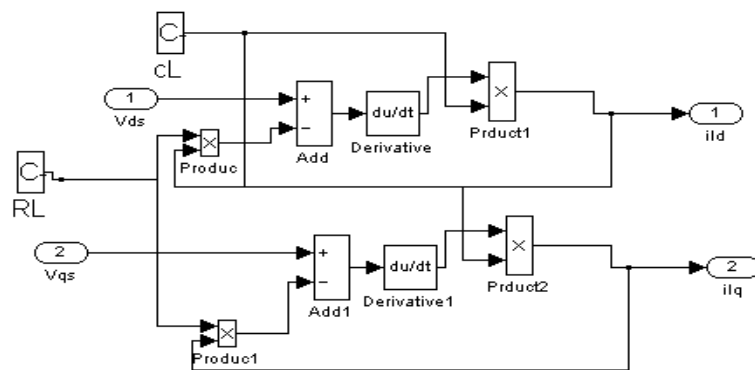

Figure 3. Internal model of balanced capacitive load

2.1.2. Capacitor model:

The capacitor has been modeled using equations (5), (6), (7) and (8) that represent the self excitation capacitor currents and voltages in d-q axes representation as [34]:

$$i_{ds} = i_{cd} + i_{ld} \tag{5}$$

$$i_{qs} = i_{cq} + i_{lq} \tag{6}$$

$$pV_{ld} = \left(\frac{3}{2K_3}\right)\left(\frac{1}{C_b} + \frac{1}{C_c}\right)i_{ds} + \left(\frac{\sqrt{3}}{2K_3}\right)\left(\frac{1}{C_b} - \frac{1}{C_c}\right)i_{qs} - \left(\frac{3}{2K_3}\right)\left(\frac{1}{C_b} + \frac{1}{C_c}\right)i_{ld} - \left(\frac{\sqrt{3}}{2K_3}\right)\left(\frac{1}{C_b} - \frac{1}{C_c}\right)i_{lq} \tag{7}$$

$$pV_{lq} = \left(\frac{\sqrt{3}}{C_b}\right)\left[\left(\frac{K_1}{K_3}\right)\left(\frac{1}{C_b} + \frac{1}{C_c}\right) - 1\right]i_{ds} - \left(\frac{\sqrt{3}}{C_b}\right)\left[\left(\frac{K_1}{K_3}\right)\left(\frac{1}{C_b} + \frac{1}{C_c}\right) - 1\right]i_{qs} - \left(\frac{\sqrt{3}}{C_b}\right)\left[\left(\frac{K_1}{K_3}\right)\left(\frac{1}{C_b} + \frac{1}{C_c}\right) - 1\right]i_{ld} + \left(\frac{\sqrt{3}}{C_b}\right)\left[\left(\frac{K_1}{K_3}\right)\left(\frac{1}{C_b} + \frac{1}{C_c}\right) - 1\right]i_{lq} \tag{8}$$

where

$$K_1 = C_a + (C_b/2),$$

$$K_2 = C_a + (C_c/2)$$

and $K_3 = (K_1/C_b) + (K_2/C_c)$

If $C_a=C_b=C_c=C$ then it's called as balanced self-excitation otherwise it's called as un-balanced excitation. The SIMULINK model of excitation capacitor is shown in Fig. 4. This model describes the capacitor model for both balanced and unbalanced excitation conditions.

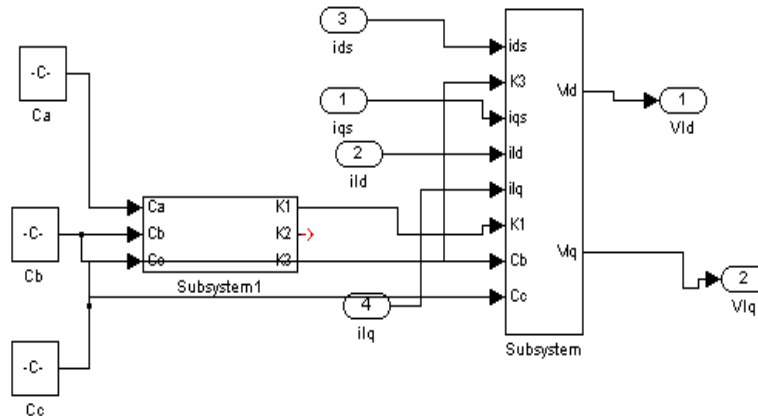

Figure 4. Simulink Model of Capacitor

The following assumptions have been considered are made in this analysis:

- [i] Core and mechanical losses in the machine are neglected.
- [ii] All machine parameters, except the magnetizing inductance (L_m), are assumed to be constant.
- [iii] The rotor should have sufficient residual magnetism.
- [iv] The three capacitor banks should be of sufficient value
- [v] Stator voltage in terms of d-q, V_{ds} and V_{qs} should have some initial voltage i.e 1 volts.

The SEIG operates in the saturation region and its magnetizing characteristics are non-linear in nature. Magnetizing current is calculated in every step of integration in terms of stator and rotor d-q currents as:

$$i_m = \sqrt{(i_{ds} + i_{dr})^2 + (i_{qs} + i_{qr})^2} \tag{9}$$

Magnetizing inductance is calculated from the magnetizing characteristics which can be obtained by synchronous speed test for the machine under test. These characteristics can be defined as:

$$L_m = 0.1407 + 0.0014i_m - 0.0012i_m^2 + 0.00005i_m^3 \tag{10}$$

Developed electromagnetic torque of the SEIG is:

$$T_e = (3p_{pole}/4)L_m(i_{qs}i_{dr} - i_{ds}i_{qr}) \tag{11}$$

Torque balance equation is:

$$T_{shaft} = T_e + j(2/p) \rho \omega_r \tag{12}$$

The derivative of the rotor speed is:

$$\rho \omega_r = (p/2) (T_{shaft} - T_e) / j \tag{13}$$

The SIMULINK model of electromagnetic torque is given as:

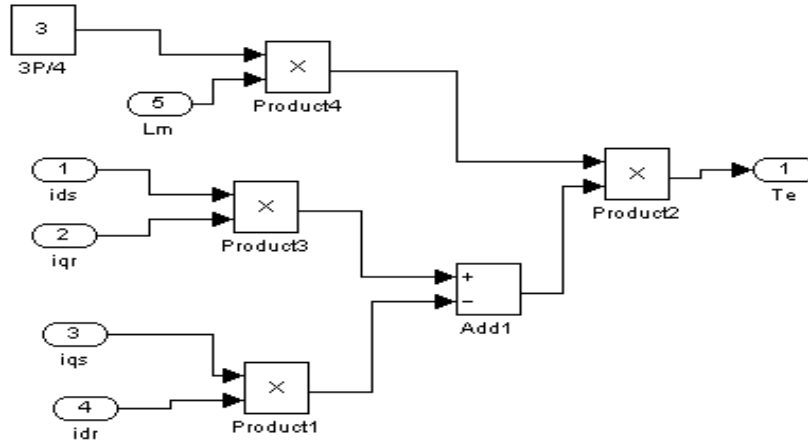

Figure 5. Electromagnetic torque

Using all subsystems developed in MATLAB, the complete model of SEIG with inductive and capacitive load and excitation is shown in Fig. 8 and is described in equation (14).

$$\begin{bmatrix} \dot{i}_{ds} \\ \dot{i}_{qs} \\ \dot{i}_{dr} \\ \dot{i}_{qr} \\ \rho V_{ld} \\ V_{lq} \\ \dot{i}_{ld} \\ \dot{i}_{lq} \end{bmatrix} = K \begin{bmatrix} L_r R_s & -\omega_r L_m^2 & -L_m R_r & -\omega_r L_m L_r & L_r & 0 & 0 & 0 \\ \omega_r L_m^2 & L_r R_s & \omega_r L_m L_r & -L_m R_r & 0 & L_r & 0 & 0 \\ -L_m R_s & \omega_r L_m L_r & L_r R_r & \omega_r L_r L_s & -L_m & 0 & 0 & 0 \\ -\omega_r L_m L_s & -L_m R_s & -\omega_r L_r L_s & L_r R_r & 0 & -L_m & 0 & 0 \\ P/K & Q/K & 0 & 0 & 0 & 0 & -P/K & -Q/K \\ R/K & -S/K & 0 & 0 & 0 & 0 & -R/K & S/K \\ 0 & 0 & 0 & 0 & 1/R_a K & 0 & 0 & 0 \\ 0 & 0 & 0 & 0 & \frac{0.577}{K} \left(\frac{1}{R_a} - \frac{1}{R_b} \right) & 1/R_b K & 0 & 0 \end{bmatrix} \begin{bmatrix} \dot{i}_{ds} \\ \dot{i}_{qs} \\ \dot{i}_{dr} \\ \dot{i}_{qr} \\ V_{ld} \\ V_{lq} \\ \dot{i}_{ld} \\ \dot{i}_{lq} \end{bmatrix} + K \begin{bmatrix} -L_r & 0 & L_m & 0 \\ 0 & -L_r & 0 & L_m \\ L_m & 0 & -L_s & 0 \\ 0 & L_m & 0 & -L_s \\ 0 & 0 & 0 & 0 \\ 0 & 0 & 0 & 0 \\ 0 & 0 & 0 & 0 \\ 0 & 0 & 0 & 0 \end{bmatrix} \begin{bmatrix} V_{ds} \\ V_{qs} \\ 0 \\ 0 \end{bmatrix} \tag{14}$$

where

$$P = \left(\frac{3}{2K_3} \right) \left(\frac{1}{C_b} + \frac{1}{C_c} \right), \quad Q = \left(\frac{\sqrt{3}}{2K_3} \right) \left(\frac{1}{C_b} - \frac{1}{C_c} \right) \tag{15}$$

$$R = \left\{ \frac{\sqrt{3}}{C_b} \left[\left(\frac{K_1}{K_3} \right) \left(\frac{1}{C_b} + \frac{1}{C_c} \right) - 1 \right] \right\}, S = \left\{ \frac{1}{C_b} \left[\left(\frac{K_1}{K_3} \right) \left(\frac{1}{C_b} - \frac{1}{C_c} \right) - 1 \right] \right\} \tag{16}$$

$$K = 1 / (L_m^2 - L_s L_r) \tag{17}$$

2.2. Wind Turbine Model

Fixed pitch wind turbine has been modeled to drive induction generator. The number of blades are taken as 3, blade radius equal is considered as 13m, and the gear ratio is taken as 30 with fixed pitch as ($\beta = 0$). Since the power coefficient characteristic of wind turbine is a non-linear curve that reflects the aerodynamic behavior a wind turbine. The characteristic forms the basis for the custom turbine model. The non-linear, dimensionless C_p characteristic is represented as [32].

$$C_p(\lambda, \beta) = C_1 \left(\frac{C_2}{\lambda_i} - C_3 \beta - C_4 \right) e^{-\frac{C_5}{\lambda_i}} + C_6 \lambda \tag{18}$$

$$\frac{1}{\lambda_i} = \frac{1}{\lambda + 0.08\beta} - \frac{0.035}{\beta^3 + 1} \tag{19}$$

where,

$$C_1 = 0.5176, C_2 = 116, C_3 = 0.4, C_4 = 5, C_5 = 21, C_6 = 0.0068$$

The power coefficient function given by (20),

$$P_m = 0.5 \rho A \left(0.5176 \left(\frac{116}{\lambda} - 9.06 \right) e^{-\frac{21}{\lambda} + 0.735} + 0.0068 \lambda \right) v_w^3 \tag{20}$$

The mechanical torque is given as:

$$t_m = 0.5 \rho A \left(0.5176 \left(\frac{116}{\lambda} - 9.06 \right) e^{-\frac{21}{\lambda} + 0.735} + 0.0068 \lambda \right) v_w^3 \frac{R}{G \lambda v_w} \tag{21}$$

The SIMULINK model of wind turbine is shown in Fig. 6. The C_p curve is obtained developing the wind turbine model in SIMULINK. The mechanical power output at air density of 1.1kpa is obtained as shown in Fig. 7.

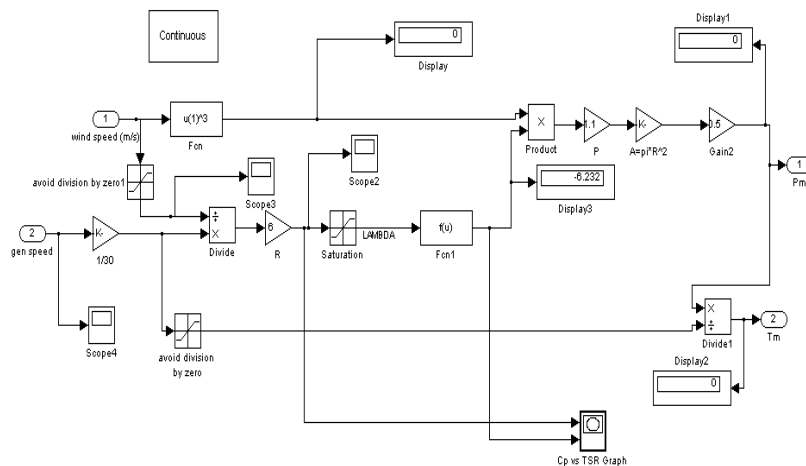

Figure 6. Custom wind turbine model (Air Density: 1.1 kpa)

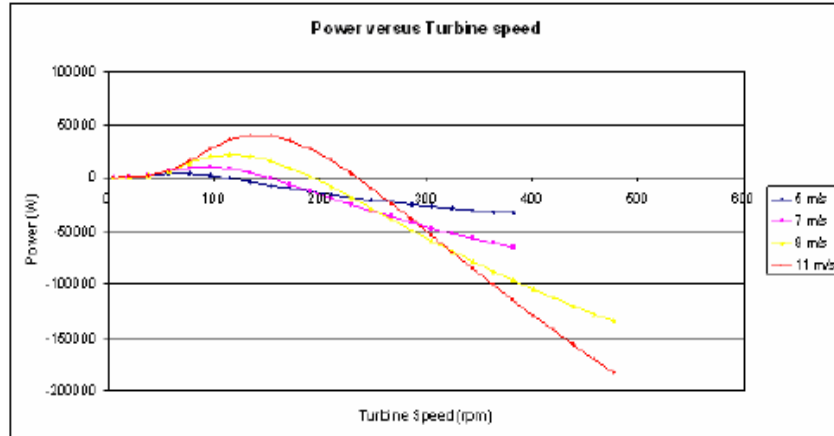

Figure 7. Output mechanical power of turbine versus the turbine speed

Using the dynamic equations described in the previous section, complete model of wind driven induction generator has been developed using MATLAB/SIMULINK toolbox [34]. The equations of self-excited induction generator for a data of 7.5 kW, 4 poles, $R_s=1\Omega$, $R_r=0.77\Omega$, $X_{lr}=X_{ls}=1\text{mh}$, $J=0.23\text{ Kg/m}^2$ described above have been implemented in MATLAB/SIMULINK. The equation (14) has been implemented in subsystem “Induction Generator” whose outputs are currents. The complete MATLAB SIMULINK model is shown in Fig. 7 with subsystems components shown in color. Equation (14) shows the eight first order differential equations, for which the solutions gives the four currents (stator d-q axis currents and rotor d-q axis currents), load currents and capacitor voltages. Further these currents are the function of constants viz. stator and rotor inductances, resistances, speed, excitation capacitance and load impedance. The variables like magnetizing inductance, magnetizing currents, and electromagnetic torque generated, has been evaluated.

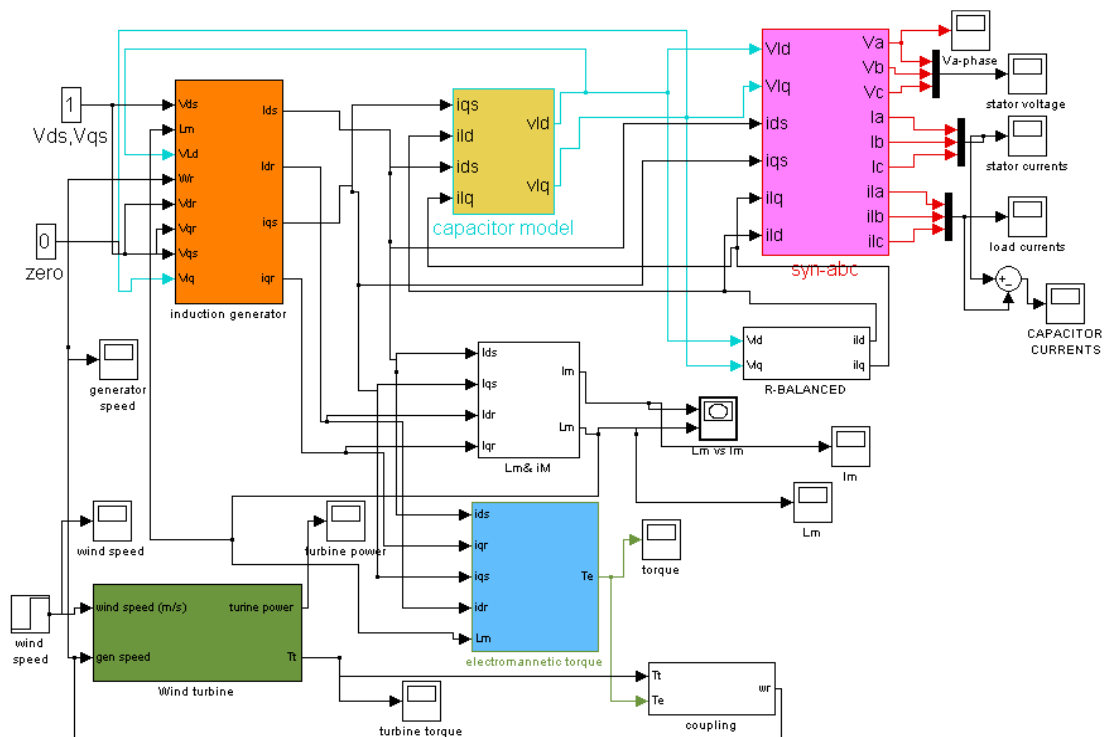

Figure 8. Complete simulink model of wind driven SEIG with load [34]

3. RESULTS AND ANALYSIS

In this paper, the results have been determined for SEIG with R-L loads taken under balanced conditions with balanced and unbalanced excitation. Two different cases taken for the study are:
Case 1: balanced R-L load and balanced excitation

Case 2: balanced R-L load and un-balanced excitation

Case 3: un-balanced R-L load and balanced excitation

Case 4: balanced R-C load and balanced excitation

Case 5: balanced R-C load and constant un-balanced excitation

These cases have been considered to observe the operation of SEIG and to analyze and the results for stator voltage, stator currents, load currents, and capacitor currents for all the cases.

3.1. SEIG Operation with R-L load

The operation of the SEIG is simulated with $R=180\ \Omega$, $L=20\ \text{mH}$ under balanced conditions and $R_a = 180\ \Omega$, $R_b = 60\ \Omega$, $L_a=20\ \text{mH}$, $L_b=0.001\ \text{mH}$, under unbalanced conditions. Generator is excited with $C=110\ \mu\text{f}$ and unbalanced excitation with $C_a=110\ \mu\text{f}$, $C_b=80\ \mu\text{f}$, $C_c= 103\ \mu\text{f}$. The results obtained with inductive R-L and R-C loads with balanced and unbalanced excitation are shown in Fig.8 to 13.

3.1.1. Case-1: R-L balanced load and constant excitation:

In Case 1: balanced exaction with balanced inductive load, all the currents, i.e. stator currents, capacitor currents and load currents are balanced. Voltage is also balanced as shown in Fig.6.6. It is observed from the Fig. 8 (graphs 1,2 3,4) that the stator voltage, currents, load currents, and capacitor currents attain their steady state value at 4.5 sec. The variation of electromagnetic torque with time and magnetizing inductance with time of SEIG has also been shown in Fig. 8 (graphs 5 and 6). The electromagnetic torque is zero initially and then it increases exponentially and attains steady values at about 5.0 sec. It is observed that the magnetizing inductance is constant of value 0.14 H up to 3.5 sec. and then reduces to 0.103 H and become constant at 5.0 sec. and remains constant.

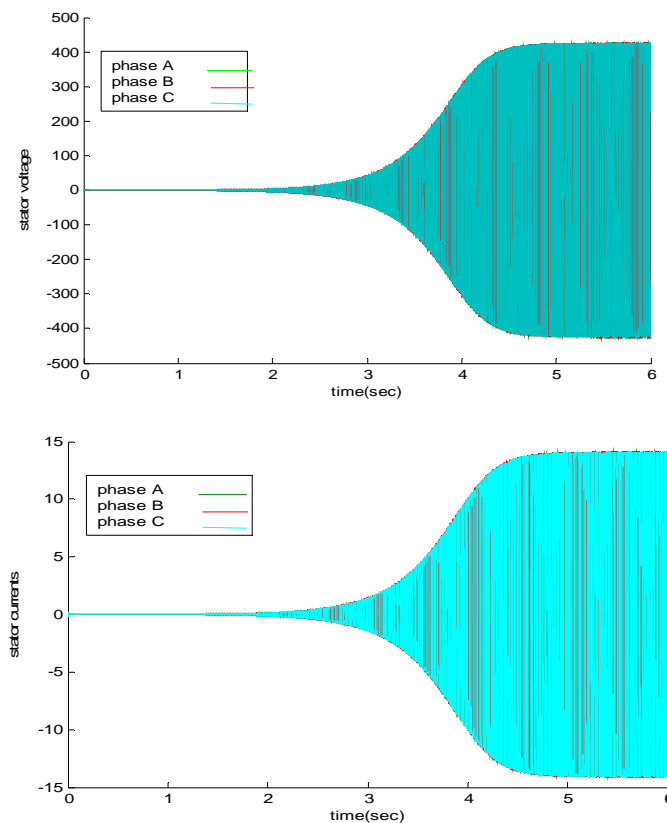

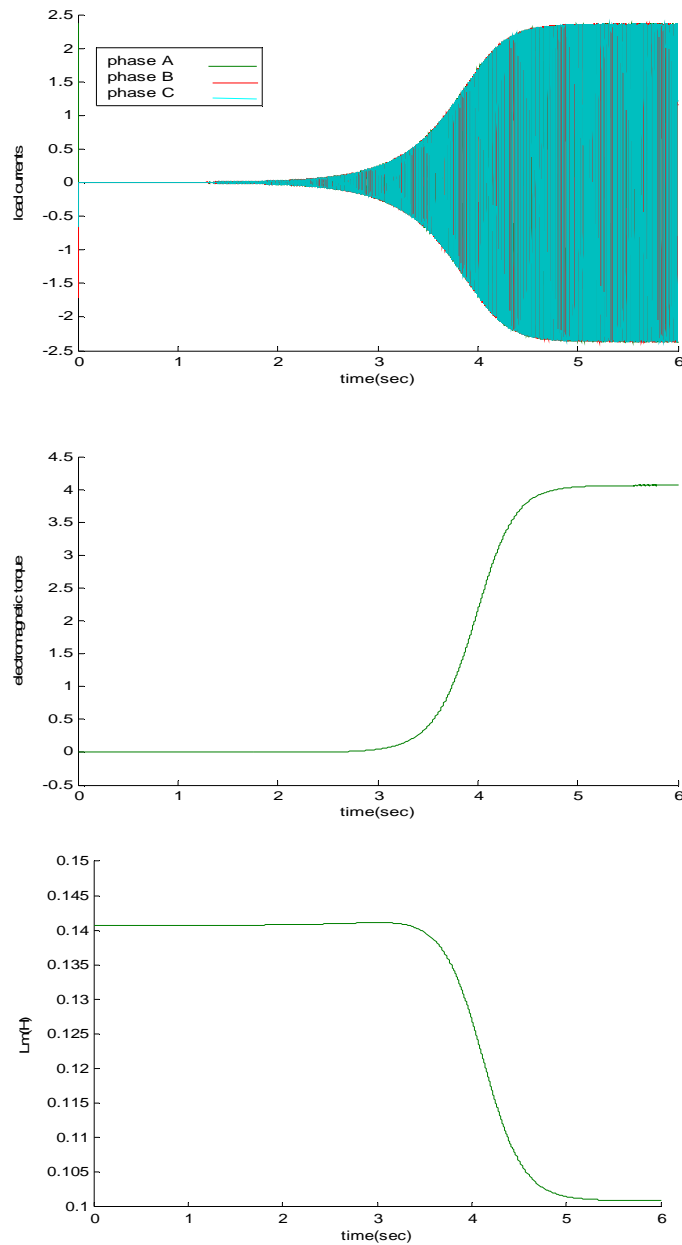
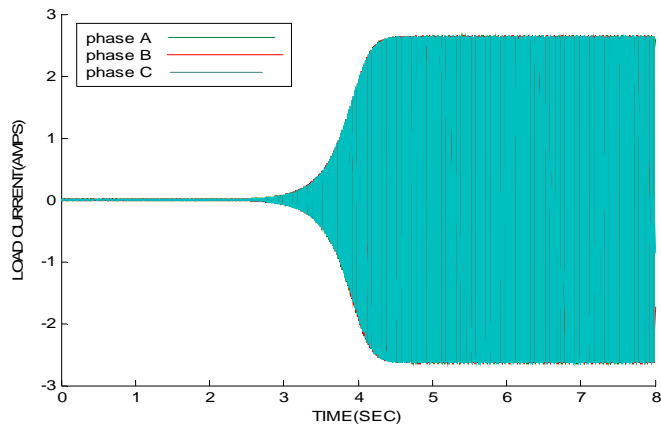
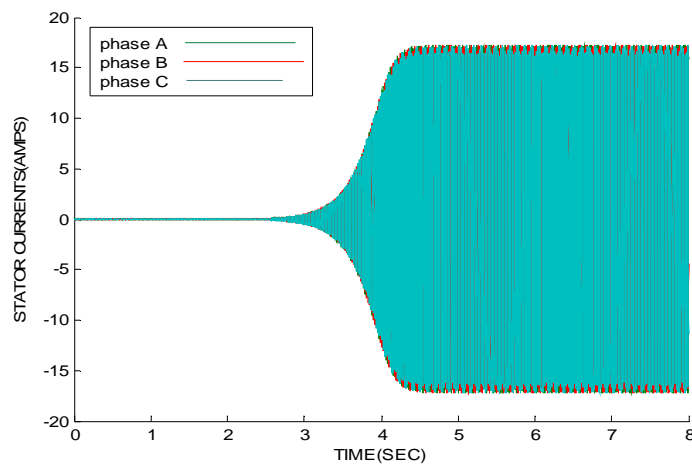
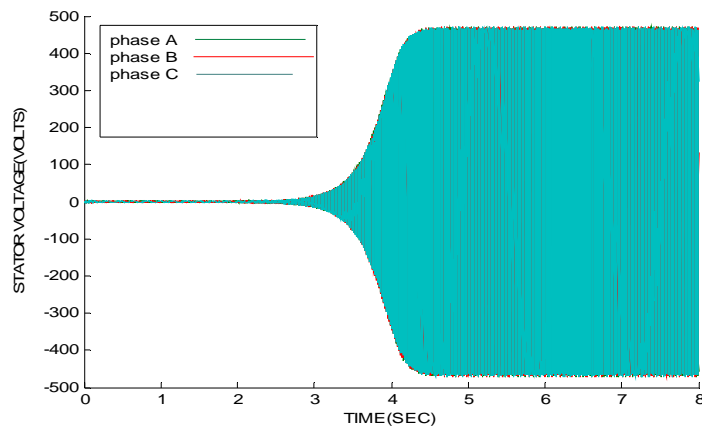

Figure 8. SEIG at balanced Inductive (RL) load with constant excitation (graphs: 1. Stator line voltages 2. Stator currents 3. Load currents 4. Capacitor currents. 5. Electromagnetic torque. 6. Magnetizing inductance)

3.1.2. Case-2: Balanced R-L load and constant unbalanced excitation:

In Case 2: unbalanced excitation and balanced inductive load, the load currents are balanced but stator currents and capacitor currents are unbalanced as shown in Fig.9. It is observed from the Fig. 9 (graphs 1, 2, 3, 4) that the stator voltage, currents, load currents, and capacitor currents attain their steady state value at 4.5 sec. The variation of electromagnetic torque with time and magnetizing inductance with time of SEIG has also been shown in Fig. 9 (graphs 5 and 6). The electromagnetic torque is zero initially and then it increases exponentially and it is observed that T_e is having oscillations due to unbalanced excitation. It is observed that the magnetizing inductance is constant of value 0.14 H up to 3.5 sec. and then reduces to 0.087 H and become constant at 5.0 sec. and remains constant.



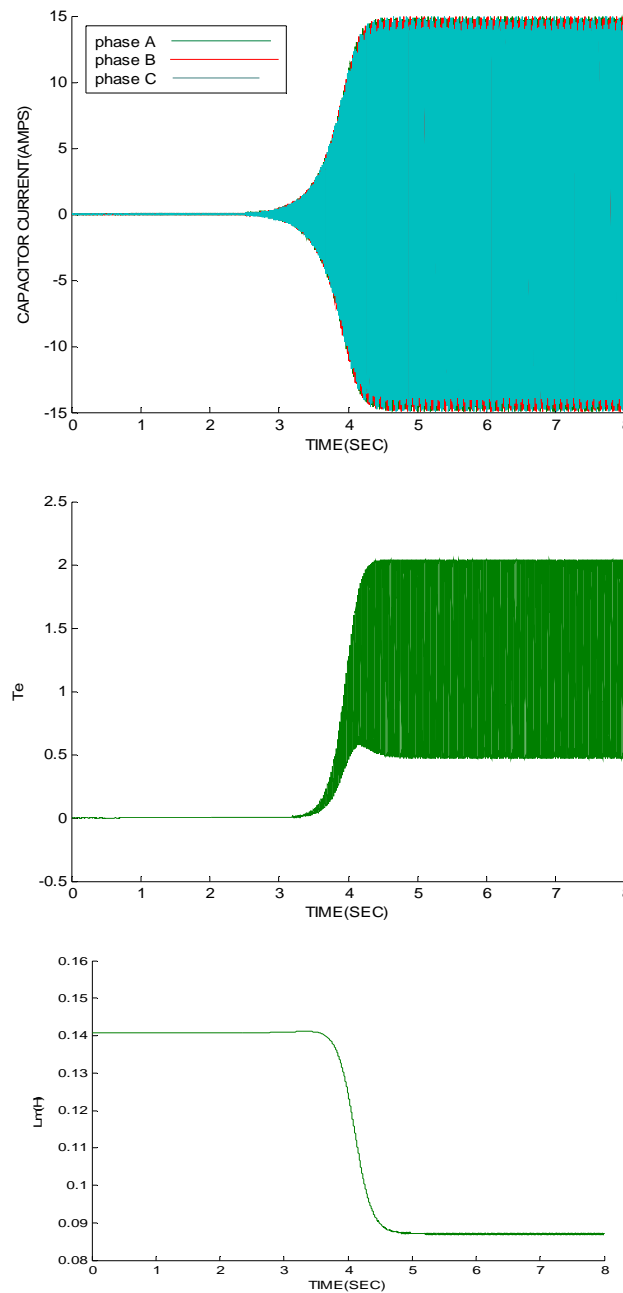
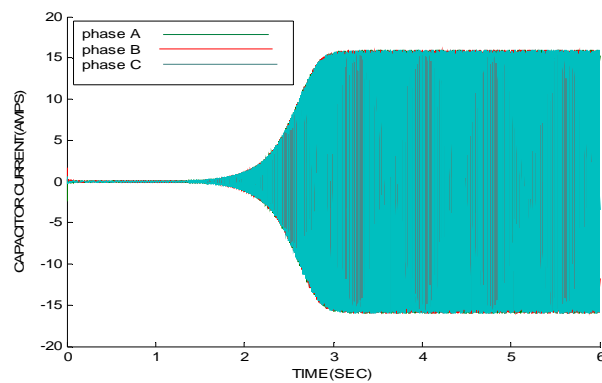
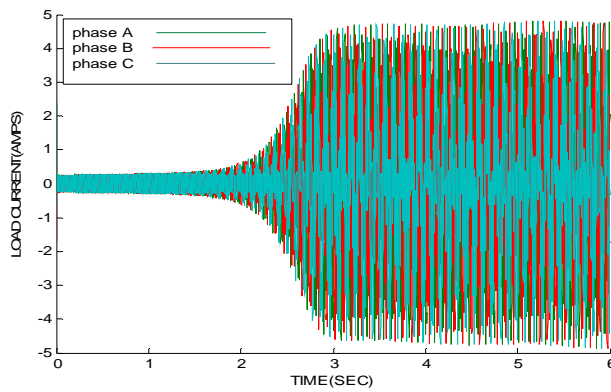
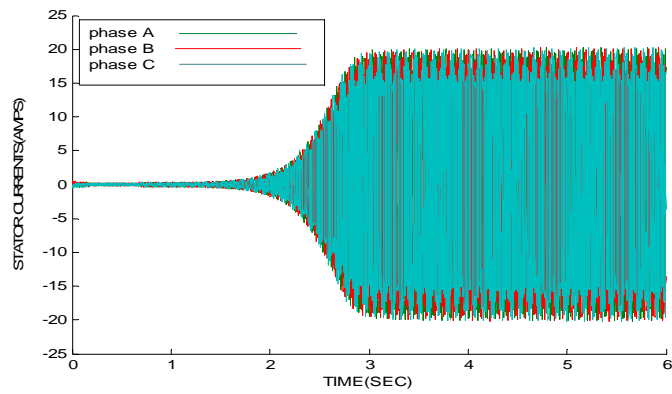
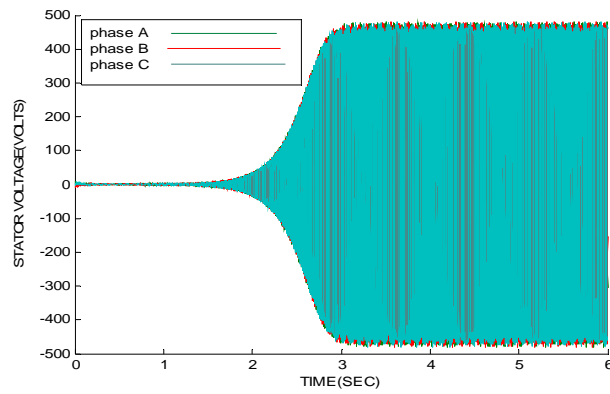

Figure 9. SEIG at balanced Inductive (RL) load with constant UN excitation (graphs: 1. Stator line voltages 2. Stator currents 3. Load currents 4. Capacitor currents. 5. Electromagnetic torque. 6. Magnetizing inductance)

3.1.3. Case-3: Unbalanced RL load and balanced excitation

In Case 3: unbalanced inductive load and balanced excitation, all currents, stator currents, load currents are un-balanced but stator voltage and capacitor currents are balanced as shown in Fig. 10. It is observed from the Fig. 10 (graphs 1, 2, 3, 4) that the stator voltage, currents, load currents, and capacitor currents attain their steady state value at 3 sec. The variation of electromagnetic torque with time and magnetizing inductance with time of SEIG has also been shown in Fig. 10 (graphs 5 and 6). The electromagnetic torque is zero initially and then it increases exponentially and attains steady values at about 2.6 sec. Oscillations are observed for Te due to unbalanced load. It is observed that the magnetizing inductance is constant of value 0.14 H up to 3.6 sec. and then reduces to 0.085 H and small oscillations are observed due to the unbalanced load.



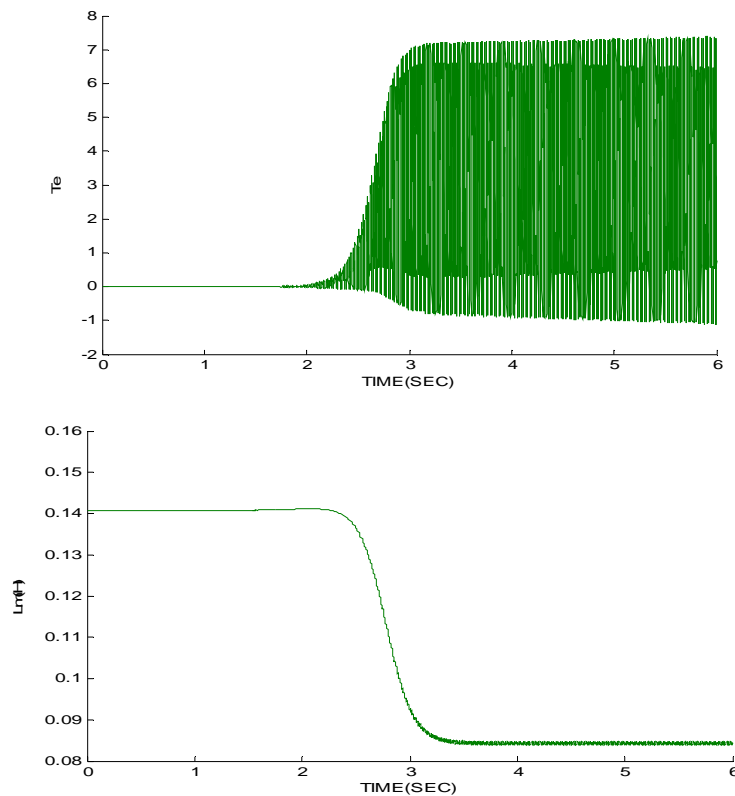
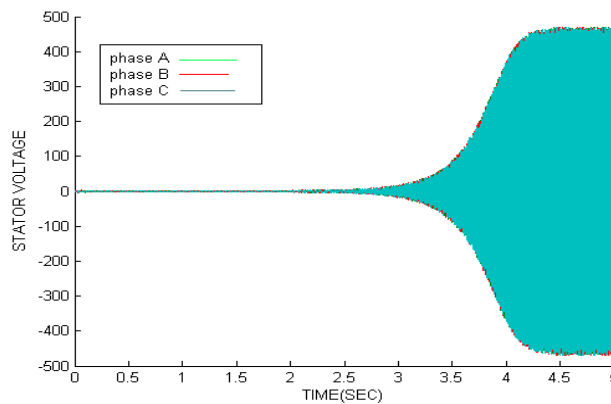

Figure10. SEIG at Un-balanced Inductive (RL) load with constant excitation (graphs: 1. Stator line voltages 2 Stator currents 3.Load currents 4.Capacitor currents. 5. Electromagnetic torque 6. Magnetizing inductance)

3.1.4. Case-4: Balanced RC load and balanced excitation

The operation of the SEIG is simulated with $R=160\Omega$. $C=20\ \mu\text{f}$ under balanced conditions. Generator is excited with $C=110\ \mu\text{f}$ and unexcited with $C_a=110\ \mu\text{f}$, $C_b=80\ \mu\text{f}$, $C_c=103\ \mu\text{f}$.

In Case4: balanced excitation with balanced RC-load all the currents, i.e. stator currents, capacitor currents and load currents are balanced. Voltage is also balanced as shown in Fig.11. It is observed from the Fig. 11 (graphs 1, 2 3, 4) that the stator voltage, currents, load currents, and capacitor currents attain their steady state value at 4.2 sec. The variation of electromagnetic torque with time and magnetizing inductance with time of SEIG has also been shown in Fig. 11 (graphs 5 and 6). The electromagnetic torque is zero initially and then it increases exponentially and attains steady values at about 4.5 sec. It is observed that the magnetizing inductance is constant of value 0.14 H up to 3.5 sec. and then reduces to 0.085 H and become constant at 5.0 sec. and remains constant.



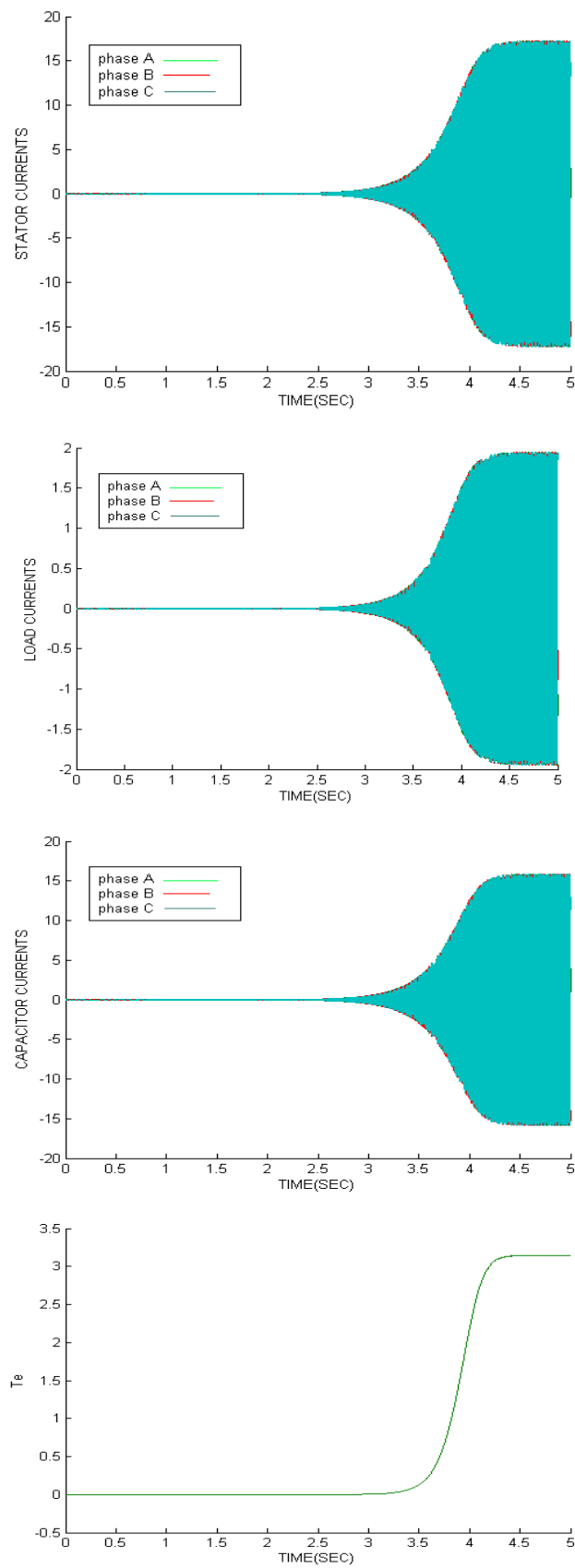

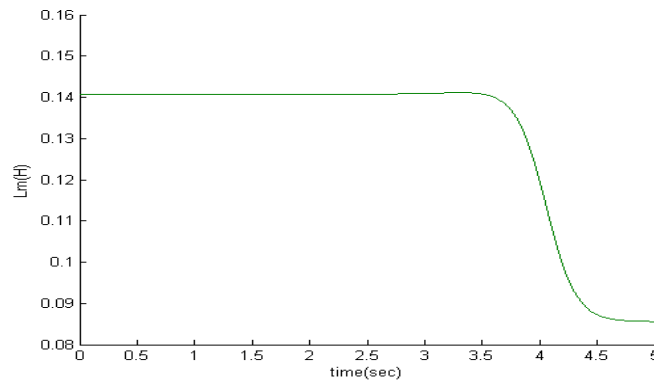
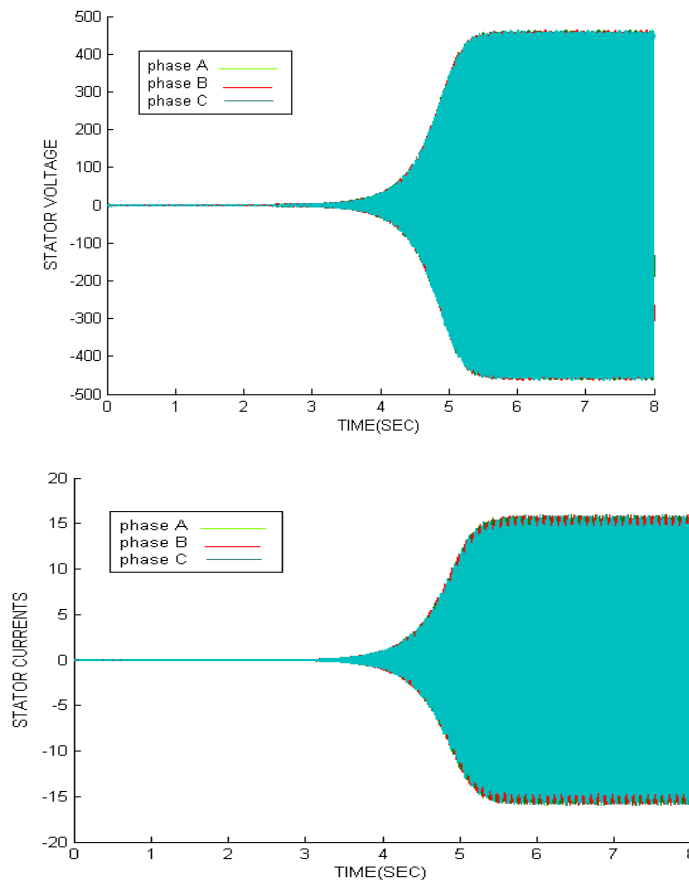

Figure 11. SEIG at Capacitive load (RC) with constant excitation (graphs: 1. Stator line voltages 2.Stator currents 3. Load currents 4.Capacitor currents. 5. Electromagnetic torque 6. Magnetizing inductance)

3.1.5. Case-5: RC balanced load with constant un-balanced excitation

In Case 5: unbalanced excitation and balanced RC load, the load currents are balanced but stator currents and capacitor currents are un-balanced as shown in Fig.12. It is observed from the Fig.12 (graphs 1, 2, 3, 4) that the stator voltage, currents, load currents, and capacitor currents attain their steady state value late compared to Case 1 at 5.2 sec. The unbalanced excitation causes slow buildup of the voltage and currents. The variation of electromagnetic torque with time and magnetizing inductance with time of SEIG has also been shown in Fig.12 (graphs 5 and 6). The electromagnetic torque is zero initially and then it increases exponentially and it is observed that T_e is having oscillations due to unbalanced excitation. It is observed that the magnetizing inductance is constant of value 0.14 H up to 4.5 sec. and then reduces to 0.095 H and become constant at 6 sec. and remains constant.



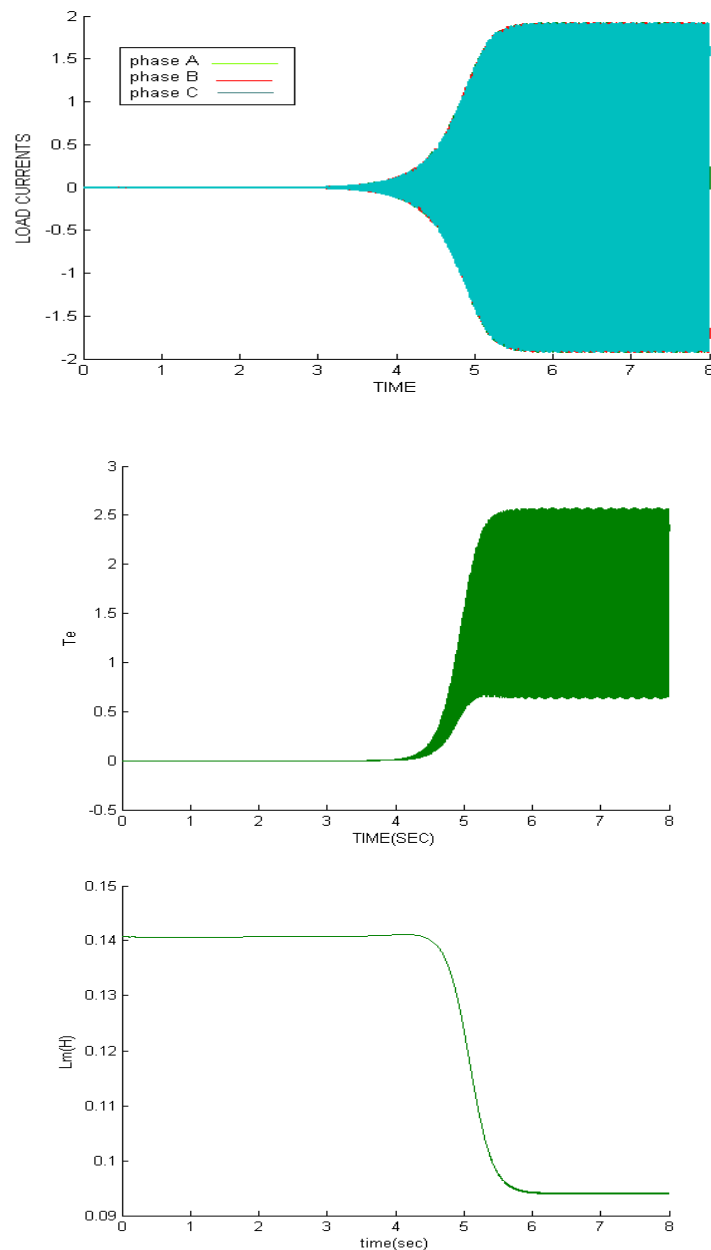

Figure 12. SEIG at Capacitive load (RC) with constant UN excitation (graphs: 1. Stator line voltages 2. Stator currents 3. Load currents 4. Capacitor currents. 5. Electromagnetic torque 6. Magnetizing inductance)

4. CONCLUSION

In this paper, the results have been determined for SEIG with R-L and R-C load under balanced and unbalanced excitation conditions. Based on the results for all the cases, the following conclusions can be drawn:

- [i] The performance of SEIG has been determined for five different cases. It is observed that the performance of SEIG under balanced R-L and R-C and balanced excitations, the stator voltage, stator currents, load currents and capacitor currents are balanced. In this case the voltage build up is quite fast because of balanced excitation.
- [ii] Under un-balanced excitation the electromagnetic torque is having oscillations compared to the case with balanced excitation and capacitor currents are unbalanced.
- [iii] Under un-balanced load and balanced excitation the electromagnetic torque have more oscillations and are more as compared to other case.
- [iv] It is observed that the stator currents and load currents are un-balanced under un-balanced load. It is balanced under balanced excitation and balanced load only.

REFERENCES

- [1] R. C. Bansal, T. S. Bhatti, and D. P. Kothari, "A Bibliographical Survey on Induction Generators for Application Of Nonconventional Energy Systems," *IEEE Trans. Energy Convers.*, vol. 18, no. 3, pp. 433–439, Sep. 2003.
- [2] E. Levy and Y. W. Liao, "An Experimental Investigation of Self-Excitation in Capacitor Excited Induction Generators," *Elect. Power Syst. Res.*, vol. 53, pp. 59–65, 2000.
- [3] P. C. Krause and C. H. Thomas, "Simulation of Symmetrical Induction Machinery," *IEEE Trans. Power App. Syst.*, vol. PAS-84, no. 11, pp. 1038–1053, Nov. 1965.
- [4] S. S. Murthy, O. P. Malik, and A. K. Tandon, "Analysis of Self Excited Induction Generator," *Proc. Inst. Elect. Eng. C*, vol. 129, no. 6, pp. 260–265, Nov. 1982.
- [5] G. Raina and O. P. Malik, "Wind Energy Conversion using a Self-Excited Induction Generator," *IEEE Trans. Power App. Syst.*, vol. PAS -102, no. 12, pp. 3933–3936, Dec. 1983.
- [6] L. Quazene and G. McPherson Jr., "Analysis of an Isolated Induction Generator," *IEEE Trans. Power App. Syst.*, vol. 102, no. PAS-8, pp. 2793–2798, Aug. 1983.
- [7] A. K. Tandon, S. S. Murthy, and G. J. Berg, "Steady state analysis of capacitor self-excited induction generators," *IEEE Trans. Power App. Syst.*, vol. PAS-103, no. 3, pp. 612–618, Mar. 1984.
- [8] A. H. Al-Bahrani and N. H. Malik, "Steady-state Analysis and Performance Characteristic of a 3-Phase Induction Generator Self-Excited With a Single Capacitor," *IEEE Trans. Energy Convers.*, vol. 5, no. 4, pp. 725–732, Dec. 1990.
- [9] S. P. Singh, B. Singh, and M. P. Jain, "Steady State Analysis of Self-Excited Pole Changing Induction Generator," *J. Inst. Eng.*, vol. 73, pp. 137–144, Aug. 1992.
- [10] L. Sridhar, B. Singh, and C. S. Jha, "Transient Performance of the Delf Regulated Short Shunt Self Excited Induction Generator", *IEEE Trans. on Energy Conversion*, vol. 10, no. 2, June 1995.
- [11] Li Wang, C. H. Lee, "A Novel Analysis on the Performance of an Isolated Self Excited Induction Generator", *IEEE Trans. on Energy Conversion*, vol. 12, no. 2, 1997, pp. 109-117.
- [12] J. L. Bhattacharya and J. L. Woodward, "Excitation Balancing of a Self Excited Induction Generator for Maximum Power Output", *IEE proc.* vol. 135, C, March, 1998.
- [13] S. S. Murthy, B. P. Singh, C. Nagmani, and K. V. V. Satyanarayana, "Studies on the Use of Conventional Induction Motors as Self Excited Generators", *IEEE Transactions on Energy Conversion*, vol. 3, no. 4, Dec. 1998, pp. 842-848.
- [14] Li Wang, Jian- Yi Su, "Dynamic Performances of an Isolated Self Excited Induction Generator under Various Loading Conditions", *IEEE Transaction on Energy Conversion*, vol. 14, no. 1, March 1999.
- [15] Li Wang, Jian- Yi Su, "Steady state analysis of an isolated self excited induction generator under unbalanced excitation capacitors", *IEEE Transaction on Energy Conv.*, Vol. 14, pp. 887 – 893, Dec. 1999.
- [16] S.K. Jain, J.D. Sharma and S.P. Singh "Transient Performance of Three-Phase Self-Excited Induction Generator During Balanced and Unbalanced Faults", *IEE Proc.-Genr. Trans. Distrib.*, vol. 149, no. 1. January 2002.
- [17] L. Wang and Sun Chung Kuo, "Steady State Performance of Self Excited Induction Generator under Unbalanced Load", in Proc. IEEE PES, 2002, pp. 408-412.
- [18] R. C. Bansal, T. S. Bhatti, and D. P. Kothari, "A Novel Mathematical Modeling of Induction Generator for Reactive Power Control of Isolated Hybrid Power Systems," *Int. J. Modeling Simulation*, vol. 24, no. 1, pp. 1–7, 2004.
- [19] R. C. Bansal, "Three Phase Self Excited Induction Generator-An Overview", *IEEE Trans. on Energy Conversion*, vol. 20, no. 2, pp. 292-299, 2005.
- [20] S. K. Jain, J. D. Sharma, and S. P. Singh, "Transient performance of three-phase self-excited induction generator during balanced and unbalanced faults," in *Proc. Inst. Elect. Eng., Gen., Transm. Distrib.*, vol. 149, Jan. 2002, pp. 50–57.
- [21] L. Wang and J. Y. Su, "Dynamic Performances of an Isolated Self-Excited Induction Generator Under Various Loading Conditions," *IEEE Trans. Energy Convers.*, vol. 14, no. 1, pp. 93–100, Mar. 1999.
- [22] M. H. Saloma and P. G. Holmes, "Transient and Steady State Load Erformance of a Stand-Alone Induction generator," *Proc. Inst. Elect. Eng., Elect. Power Appl.*, vol. 143, pp. 50–58, 1996.
- [23] L. C. Tsung and C. W. Lin, "Transient Simulation Technique for Studies of Self-Excited Generator Systems," *Electr. Power Syst. Res.*, vol. 33, no. 2, pp. 101–109, 1995.
- [24] D. Seyoum, C. Grantham, and M. F. Rahman, "The Dynamic Characteristics of an Isolated Self-Excited Induction Generator Driven by a Wind Turbine," *IEEE Trans. Ind. Appl.*, vol. 39, no. 4, pp. 936–944, Jul./Aug. 2003.
- [25] R. Datta and V.-T. Ranganathan, "A Method of Tracking the Peak Power Points for a Variable Speed Wind Energy Conversion System," *IEEE Transactions on Energy Conversion*, vol. 18, pp. 163–168, March 2003.
- [26] M. Gody Simoes, Felix A. Farret, second edition, "Alternative Energy Systems , Design and Analysis with Induction Generators". CRC Press, Taylor & Francis Group, Boca Raton London, New york @ 2008.
- [27] Casielles, P.G.; Zarauza, L.; Sanz, J. "Analysis and Design of Wind Driven Self Excited Induction Generator", in Proc. Industry Applications Society Meetins, pp. 116-123, 1988.
- [28] D. Seyoum and M. F. Rahaman, "The Dynamic Characteristics of A Self Excited Induction Generator Driven by Wind Turbine", in Proc. Industry Application Conf., vol. 2, 2002, pp. 731-738.
- [29] S. Wakhende and V. Aggarwal, "Wind Driven Self Excited Induction Generator with Decoupled Excitation Control", in *Proc. Industry Applications Conf. 34th IAS Annual Meetings*, pp. 2077-2083, 1999.

- [30] T. Ahmed, O. Noro, K. Matzuo, Y. Shindo, and M. Nakaoka, "Minimum Excitation Capacitance Requirements for Wind Turbine Coupled Stand-Alone Self-Excited Induction Generator with Voltage Regulation Based on SVC," *IEEE Trans.*, pp. 396 – 403, Oct. 2003.
- [31] F.A. Farret, B. Palle, M.G. Simoes "State Space Modeling of Parallel Self-Excited Induction Generators for Wind Farm Simulation" *IEEE Transaction on Industry Applications*, vol. 41, no. 4, July/August 2005.
- [32] A. Kishore, and G. S. Kumar, "A Generalized State-Space Modeling of Three Phase Self-Excited Induction Generator For Dynamic Characteristics and Analysis," In *Proc. IEEE Conf.*, pp. 1 – 6, May 2006.
- [33] G. S. Kumar and A. Kishore, "Dynamic analysis and control of output voltage of a wind turbine driven isolated induction generator", in *Proc. IEEE Conf. ICIT*, 2006, pp. 494-499.
- [34] K. Trinadha and Ashwani Kumar, "Performance of Wind Driven Induction Generator under Balanced/Unbalanced Load and Excitation", *IEEE PES GM*, 2011.
- [35] Matlab / Simulink Sim Power Systems Documentation <http://www.mathworks.com>

BIOGRAPHY OF AUTHORS

K. Trinadha is a masters student in Power Systems. He has interest in the area of electrical machine, wind energy conversion systems.



Ashwani Kumar graduated in Electrical Engineering in 1988 from GBPUA&Tech. Pant Nagar, did his masters in the area of Power Systems in 1994 in honors from Punjab University, Chandigarh. He did his Ph.D. from IIT Kanpur in 2003. Presently he is an Associate Prof. in the Department of Electrical Engineering at National Institute of Technology, Kurukshetra. He has interests in Power Systems deregulation and restructuring, Distributed Generation, Demand side management, renewable energy systems, FACTS applications to Power Systems, and Price forecasting. He is life member of professional bodies as ISTE, IEI (India) and member of IEEE/PES.

K. S. Sandhu did his B.Sc. Engg from Kurukshetra University, Kurukshetra, Masters from Kurukshetra University Kurukshetra, and Ph.D. from Kurukshetra University, Kurukshetra. He is Professor in the Department of Electrical Engineering. He has interests in the area of electrical machines, wind energy conversion systems, and renewable energy systems. He is a life member of ISTE, member of Institution of Engineers, India.