

A new design of a microstrip rectenna at 5.8 GHz for wireless power transmission applications

Taybi Abdellah¹, Abdelali Tajmouati², Jamal Zbitou³, Ahmed Errkik⁴, Mohamed Latrach⁵

^{1,2,3,4}LMEET, FST of Settat, Hassan 1st University, Settat, Morocco

⁵Microwave Group ESEO Angers, France

Article Info

Article history:

Received Apr 25, 2018

Revised Sep 12, 2018

Accepted Oct 7, 2018

Keywords:

Advanced design system

Patch antenna

Rectenna

Schottky diode

Wireless power transmission

ABSTRACT

Due to the ever-increasing power demand, the need of electricity and eco-friendly power in every nook and corner of the world, many research topics have been devoted to deal with this problematic. This paper is taking part of the proposed solutions with the presentation of a novel 5.8 GHz rectenna system for wireless power transmission applications. In one hand, a miniaturized 5.8 GHz circular polarized patch antenna has been designed and simulated by using the Advanced Design System (ADS). In the other hand, a rectifier structure has been investigated and optimized by the use of the Harmonic Balance method available in ADS. The circuit is based on 5 HSMS2820 Schottky diodes implemented in a voltage multiplier topology and a load resistance of 1 K Ω . Both of the structures have been validated by simulation and experimental results and good agreement has been concluded.

Copyright © 2019 Institute of Advanced Engineering and Science.

All rights reserved.

Corresponding Author:

Taybi Abdellah,

Faculty of Sciences and Techniques,

Hassan 1st University,

University Complex Casablanca road, Km 3.5, B.P: 577 Settat, Morocco.

Email: taybi.abdellah@gmail.com

1. INTRODUCTION

Wireless power transmission has gained great attention in recent years as one of the technologies for changing the way of supplying energy [1]-[3]. As a key component in a wireless power transmission system, the rectenna undertakes the main task to convert the received RF power into DC power which can then be consumed by other parts of the system [4], [5].

The rectenna (Rectifying Antenna) [6], [7] contains a receiving antenna and an RF-DC conversion circuit. The RF-DC conversion circuit often consists of one or more Schottky diodes, and a DC output filter. A rectenna is generally loaded by a resistive element that represents the input impedance of the device to be powered.

The function of the antenna is to receive the electromagnetic wave in the environment. Various types of the receiving antennas have been applied into the WPT systems [8]-[13]. The use of circularly-polarized antennas [8] has the advantage of avoiding polarization alignment problem as well as reducing polarization loss, as compared to linearly-polarized antennas. For the case of incoming electromagnetic wave with lower power density, a high gain antenna or a large array [9] is required to harvest sufficient RF power delivered to the rectifying circuit so that the rectenna has acceptable conversion efficiency.

Among all this diversity of antenna types presented in the literature, Microstrip antennas have found extensive application in modern communication systems because of their inherent properties such as small size, light weight, easy fabrication with low cost on mass production and possibility of integration with other printed circuit microwave components. The basic antenna element is a thin conductor of dimensions $L \times W$

on a dielectric substrate of permittivity ϵ_r , loss tangent $\tan \delta$ and thickness h backed by a conducting ground plane. This configuration is shown in Figure 1.

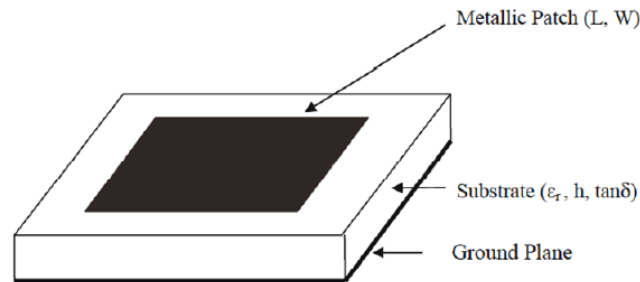

Figure 1. Rectangular microstrip antenna configuration

Various shapes could be used as a radiating element. Otherwise, the operating frequency has a significant weightiness on the antenna's size. Several operating frequencies of the rectenna have been considered and investigated. Components of microwave power transmission have traditionally been focused on 2.45 GHz and recently moving up to 5.8 GHz, which has a smaller antenna aperture area than that of 2.45 GHz. Both frequencies have comparably low atmospheric loss, cheap components availability, and reported high conversion efficiency.

In order to get done a complete rectenna system, we have developed a patch antenna at 5.8 GHz with a miniaturized size fed by microstrip technology using FR4 substrate (dielectric permittivity constant 4.4, thickness of 1.6mm and loss tangent of 0.025) combined with a voltage multiplier rectifier using five HSMS2820 schottky diodes at 5.8 GHz with satisfying results.

2. ANTENNA ANALYSIS AND DESIGN

2.1. Analysis

Microstrip antennas are also referred to as patch antennas because of the radiating elements photo-etched (patches) on the dielectric substrate. This radiating patch may be square, rectangular, circular, elliptical, triangular, and any other configuration. In this work, rectangular microstrip patch antenna is taken under consideration.

2.1.1. Calculation of width (W)

For an effective radiator, practical width of the patch antenna that leads to good radiation efficiencies is given by [14]:

$$W = \frac{c_0}{2F_0} \sqrt{\frac{2}{1 + \epsilon_r}} \quad (1)$$

Where C_0 is the free-space velocity of light i.e. 3×10^8 m/s and ϵ_r is the dielectric constant of material.

2.1.2. Calculation of effective dielectric constant ϵ_{reff}

The value of effective dielectric constant is less than dielectric constant of the substrate, because of the fringing fields are not confined in dielectric substrate around the periphery of the patch only, but is also spread in the air. The value of this effective dielectric constant is given by [14]:

$$\epsilon_{\text{reff}} = \frac{\epsilon_r + 1}{2} + \frac{\epsilon_r - 1}{2} \left[1 + 12 \frac{h}{W} \right]^{-1/2} \quad (2)$$

2.1.3. Calculation of length (L)

The length of the patch determines the resonance frequency thus it is a critical factor for narrowband patch. Since it is not possible to accurately account the fringing field the results are not definite. Below is the equation to calculate the length of the patch:

$$L = \frac{\lambda_{eff}}{2} - 2\Delta L \quad (3)$$

Where ΔL is the length extension because of fringing field, which can be calculated as follow:

$$\Delta L = 0.412 h \frac{(\epsilon_{reff}+0.3)\left(\frac{W}{h} + 0.264\right)}{(\epsilon_{reff}-0.258)\left(\frac{W}{h} + 0.8\right)} \quad (4)$$

2.1.4. Feeding methods

Many configurations are used to feed microstrip antennas. The four most popular are the microstrip line, coaxial probe, aperture coupling, and proximity coupling. In this work, the microstrip feed line is used; it is also a conducting strip, usually of much smaller width compared to the patch. The microstrip-line feed is easy to fabricate, simple to match by controlling the inset position and rather simple to model.

2.2. Design

Figure 2 shows the geometry of the proposed patch antenna which functions at 5.8 GHz.

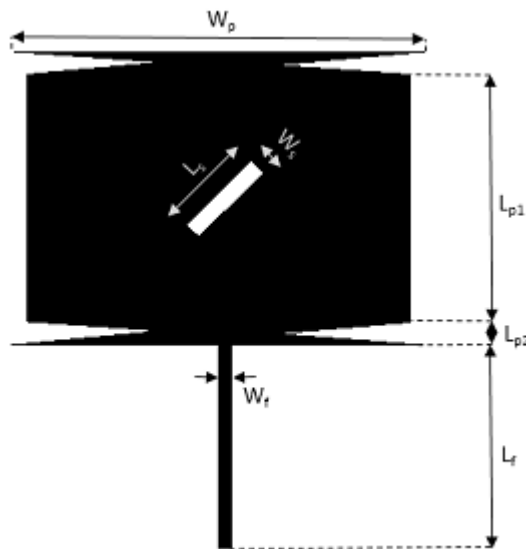

Figure 2. The proposed patch antenna

For a given antenna, the determination of the radiated wave goes through the resolution of the Maxwell equations. This difficult problem of mathematical physics is not generally analytically soluble, even for the simplest structures. Nowadays, due to the computer and the use of electromagnetic or digital codes, the design of complex antennas becomes possible. Thus, electromagnetic simulators have become essential tools for assisting the design of devices and systems. They are based on exact numerical methods that give accurate results. These methods solve the Maxwell equations or derived forms and are applied to different formulations with all their advantages and disadvantages. However, their use implies a calculation time that is often prohibitive because it involves discretizing the volume or the surface to be analyzed. This is one of the weak links in the CAD process. A compromise is therefore to be made between the search for performance and a simple modeling of the antenna according to the application. In our case, we have used the momentum simulator from Advanced Design System [15] with the definition of the mesh density to obtain results as accurate as possible. As shown in the Figure 3, the developed antenna has a good matching input impedance at 5.8 GHz.

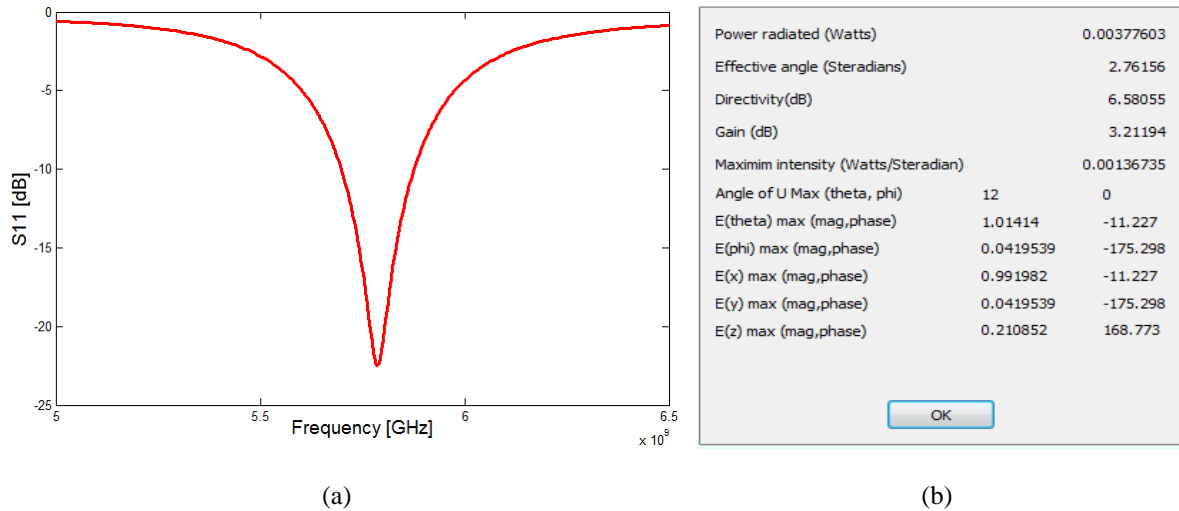

Figure 3. (a) Simulated reflection coefficient versus frequency (b) Farfield antenna parameters

3. 5.8 GHz RF-DC RECTIFIER DESIGN

RF-DC conversion structures are generally built around diodes or diode-mounted transistors. The diodes are characterized by a threshold voltage which must be exceeded in order to put them in a conduction state. When the incident power level is important, the diode threshold voltage is not a limiting factor, because the amplitude of the incident signal is significantly higher than the threshold voltage of the diodes. In the case of very low levels of incident power, the losses due to the threshold voltages of the diodes become predominant. Mostly Schottky diodes are used because of their low threshold voltage and low junction capacity. Figure 4 shows the equivalent circuit model of the Schottky diode, which has a series resistance R_s , a junction capacitance C_j , a junction resistance R_j , a package inductance L_p , and a package capacitance C_p , its forward-bias turn-on voltage V_{bi} and breakdown voltage V_B .

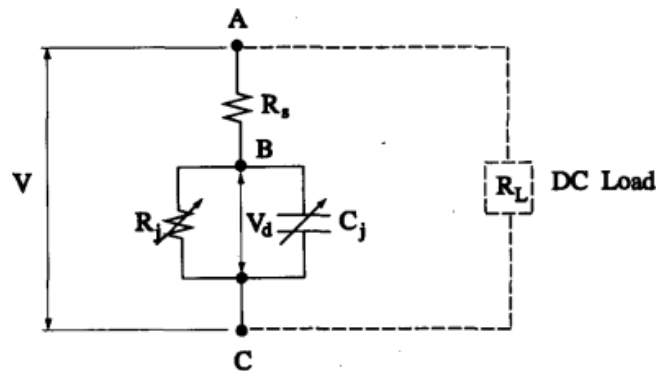

Figure 4. The equivalent circuit model of the Schottky diode [16]

The structure of the voltage multiplier rectifier circuit is given in Figure 5(a). It has been designed for an input power range from -20dBm to 30dBm. The choice was made to use Schottky diodes with low threshold voltages and low junction capabilities, ie Agilent HSMS2820 [17]. Five of this type of diodes have been used to design the rectifier structure, interconnected by using the microstrip technology well known by the low manufacturing cost. The difficulty encountered in optimizing a rectenna comes from the nonlinear aspect of the rectifying diode, which causes a variation in the impedance of the overall circuit as a function of the operating power. As a result, the output power is no longer a linear function of the input power. Thus, depending on the incident power and the load of the rectifier we get maximum efficiency for a well-defined operating point. The optimization procedure is based on the ratio of the DC output power to the incident power (collected by the antenna), by optimizing the dimensions of the input matching circuit.

For optimization, we consider that the impedance of the antenna tends to 50Ω to f_0 , which allows us to replace it with a 50Ω generator. The microstrip lines have been optimized by defining the lengths and widths criteria analysis (the optimization function available in ADS) to allow maximum energy transfer and, consequently, good performances in terms of output voltage and conversion efficiency.

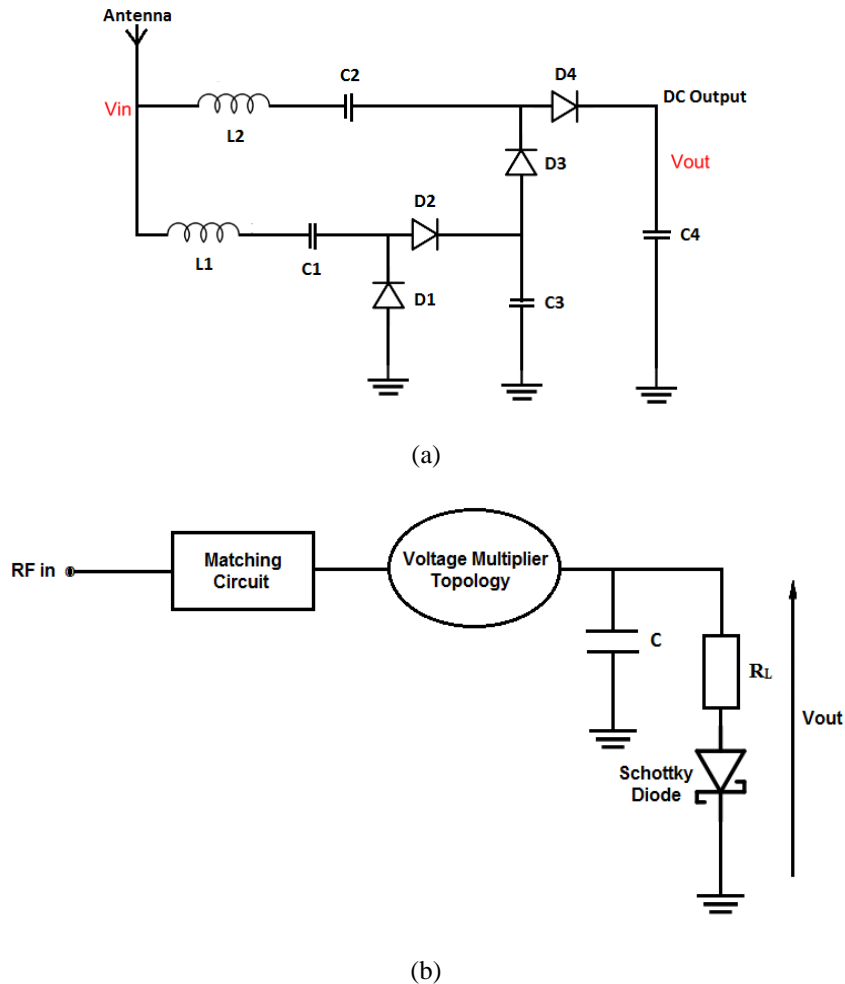

Figure 5. (a) The proposed rectifier topology, (b) Microwave rectifier detection sensitivity improvement configuration

To be able to judge the rectifier performances, many indicators must be presented and analyzed. The conversion efficiency undertakes top of the list of important performance indicators. The efficiency of the rectenna system is basically equivalent to its transfer function. The general definition of any efficiency (η) used hereafter is the ratio of the output power P_{out} over the input power P_{in} : $\eta = P_{out}/P_{in}$. Figure 6 shows the simulated conversion efficiency versus input power. The conversion efficiency reaches a value of 43% for an input power of 27dBm. The circuit starts to detect at a low power level and efficiency increase as the input power level increase. As a second important performance indicator, we have simulated the output voltage versus input power, as shown in the figure; a high voltage of 18 V is reached at 30 dBm.

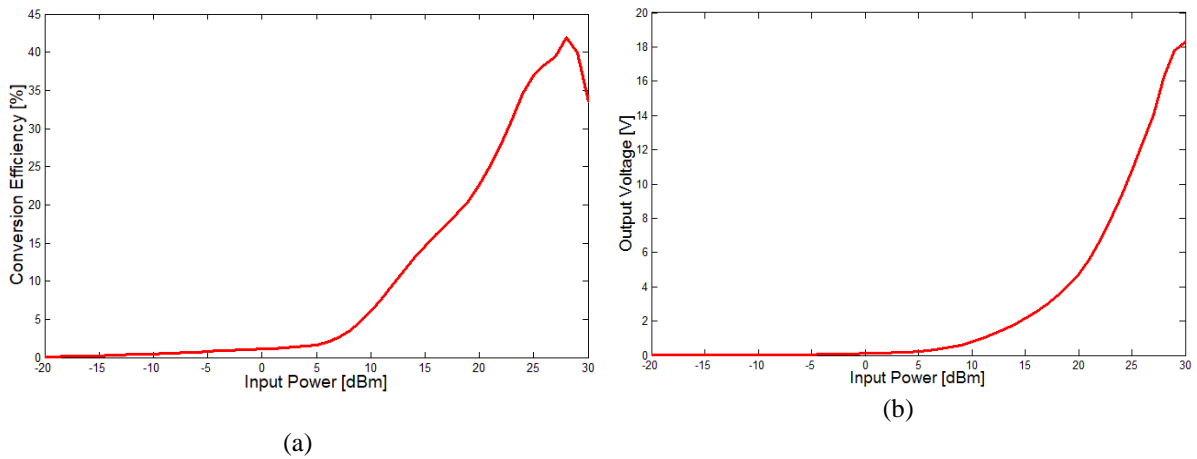

Figure 6. (a) Simulated rectifier efficiency versus input power, (b) Simulated output voltage versus input power of the rectifier

4. ACHIEVEMENT AND MEASUREMENT

It is necessary to check the results provided by the simulator. The best way being the measurement, the rectenna has been sized to respond to applications at 5.8 GHz of the ISM band. Owing to equipment limitations, a maximum input power of 18 dBm was applied. We have used as a substrate the FR4 with dielectric permittivity constant 4.4, thickness of 1.6mm and loss tangent of 0.025. Several stages (from Printing the mask on a tracing paper to welding components and SMA ports) have been done to fabricate the rectenna structure by using the chemical method. The antenna was tested in an anechoic chamber to extract the radiation pattern, and using a Vector Network Analyzer to validate the matching input impedance. In addition, the rectifier performances were confirmed by the use of the measurement setup illustrated in Figure 7. The measured reflection coefficients are depicted in Figure 8, the values are recorded in the frequency band [5.6-6] GHz for the rectifier and [5-6] GHz for the antenna. The measured and simulated reflection coefficients at 5.8 GHz are in good agreement. Figure 9 shows the measured E-plan antenna radiation pattern at 5.8 GHz for azimuth plan of 0, 45 and 90°

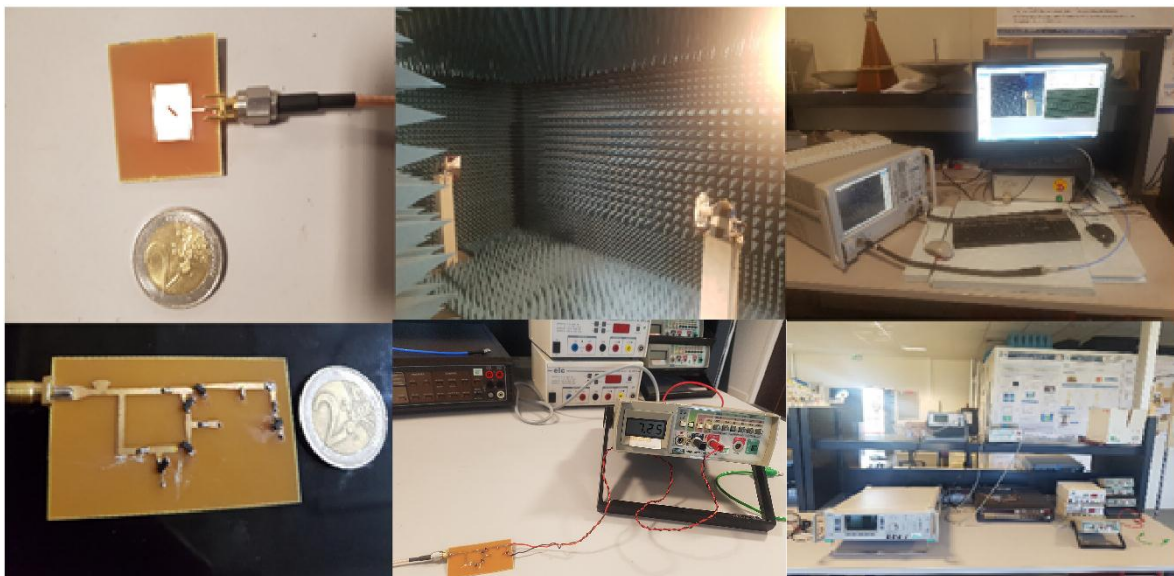

Figure 7. Fabricated rectenna system

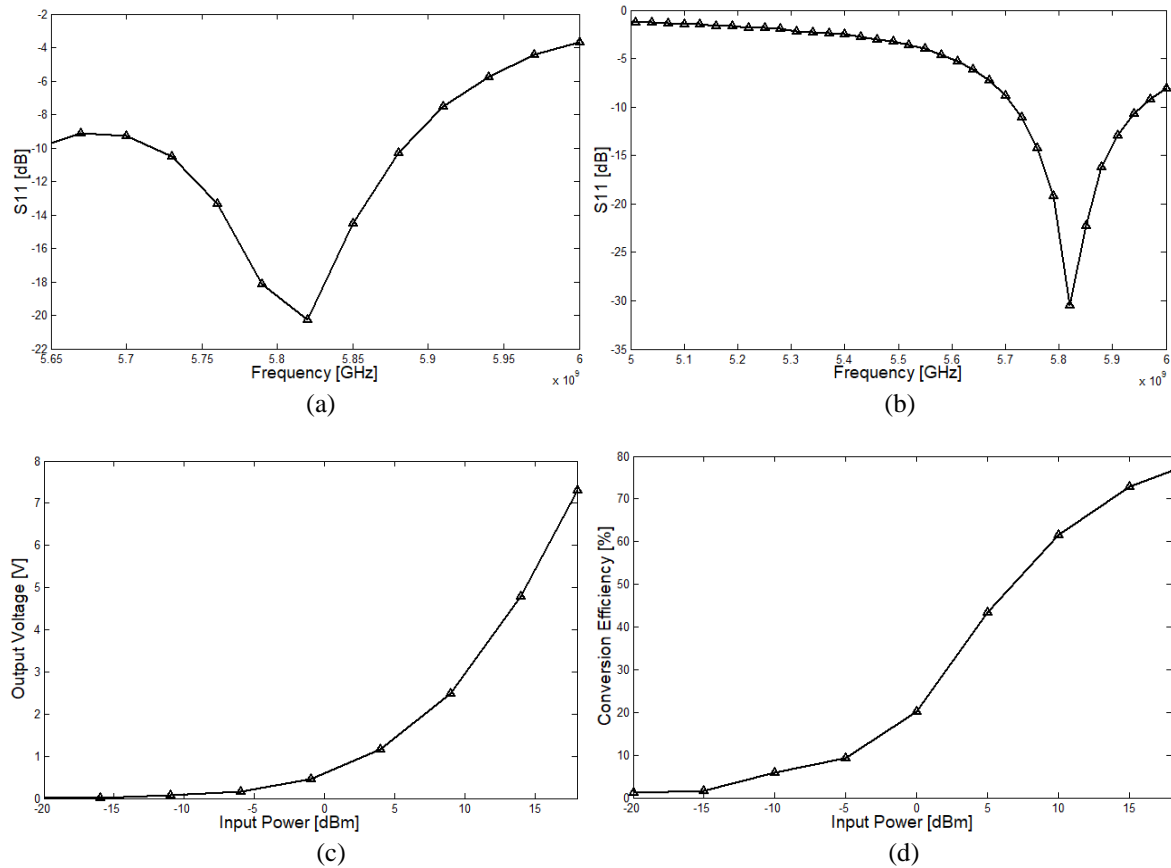

Figure 8. Measured results of the rectenna. (a) S11 versus frequency (for Rectifier) (b) S11 versus frequency (for Antenna) (c) Output voltage versus input power (d) Conversion efficiency versus input power

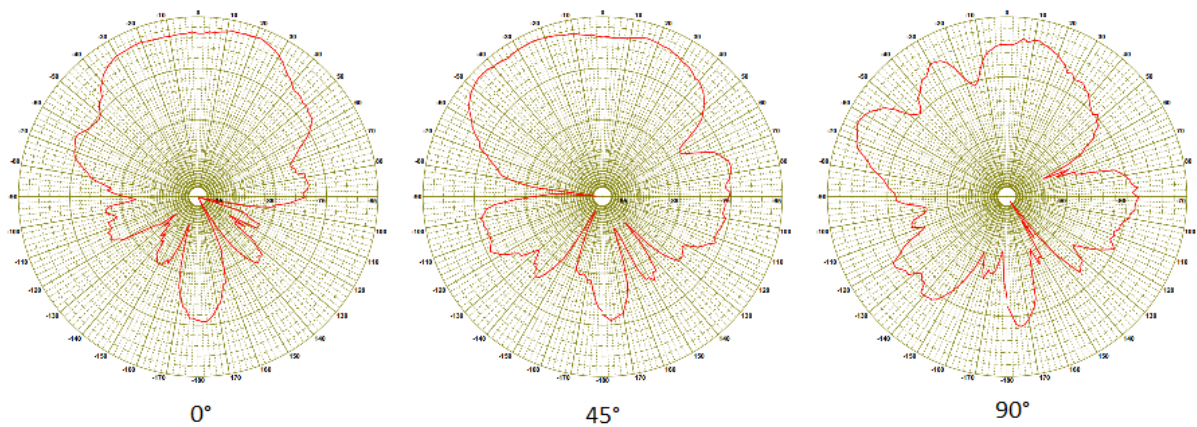

Figure 9. The measured E-plan antenna radiation pattern at 5.8 GHz for azimuth plan of 0, 45 and 90°

5. CONCLUSION

An overview of 5.8 GHz Rectenna system has been carried out, with special emphasis on configurations that are particularly attractive for their simplicity and design flexibility. Attention has been accorded to the voltage multiplier rectifier for being the key element of the system. This latter is based on five HSMS schottky diodes well known by their good performance in RF applications, implemented by using the microstrip technology. The second part is about a miniature 5.8 GHz patch antenna designed to

operate in a circular polarized way. This rectenna structure shows good performances in terms of conversion efficiency and output voltage level.

REFERENCES

- [1] K. M. Z. Shams and M. Ali, "Wireless power transmission to a buried sensor in concrete " *IEEE Sensors Journal*, vol. 7, no. 12, pp. 1573–1577, 2007.
- [2] M. Sudou, H. Takao, K. Sawada, and M. Ishida, "A novel RF induced power supply system for monolithically integrated ubiquitous micro sensor nodes," *Sensors and Actuators A*, vol. 145 146, no. 1-2, pp. 343–348, 2008.
- [3] M. A. Adeeb, A. B. Islam, M. R. Haider, F. S. Tulip, M. N. Ericson, and S. K. Islam, "An inductive link-based wireless power transfer system for biomedical applications," *Active and Passive Electronic Components*, vol. 2012, Article ID 879294, 11 pages, 2012.
- [4] Jamal Zbitou, Mohamed Latrach "Hybrid Rectenna and Monolithic Integrated Zero-Bias Microwave Rectifier," *IEEE Transactions On Microwave Theory And Techniques*, Vol. 54, No. 1, January 2006
- [5] Fang Zhang, Fan-Yi Meng, Jong-Chul Lee, Qun Wu, "Study of a Novel Compact Rectenna for Wireless Energy Harvesting," *IEEE International Wireless Symposium (IWS) Conference*, pp. 1-4, 2013
- [6] D. H. Chuc and B. G. Duong, "Investigation of Rectifier Circuit Configurations for Microwave Power Transmission System Operating at S Band," *International Journal of Electrical and Computer Engineering (IJECE)*, vol/issue: 5(5), pp. 967-974, 2015.
- [7] Deepak Kumar, Kalpana Chaudhary, " High Efficiency Harmonic Harvester Rectenna for Energy Storage Application," *International Journal of Power Electronics and Drive System (IJPEDS)*, Vol. 9, no. 1, pp. 252-259, March 2018.
- [8] Zied Harouni, Laurent Cirio, Lotfi Osman, Ali Gharsallah. and Odile Picon, "A Dual Circularly Polarized 2.45-GHz Rectenna for Wireless Power Transmission," *IEEE Antennas Wireless Propag. Lett.*, Vol. 10, pp. 306-309, 2011.
- [9] Yu-Jiun Ren and Kai Chang, "5.8-GHz Circularly Polarized Dual Diode Rectenna and Rectenna Array for Microwave Power Transmission," *IEEE Transactions On Microwave Theory And Techniques*, Vol. 54, No. 4, pp. 1495-1502, Apr. 2006
- [10] H. Takhedmit, L. Cirio, S. Belial, D. Delcroix and O. Picon, "Compact and efficient 2.45 GHz circularly polarised shorted ring-slot rectenna," *Electron. Lett.*, Vol. 48, No. 5, Mar. 1, 2012.
- [11] Fu-Jhuan Huang, Tzong-Chee Yo, Chien- Ming Lee, and Ching Hsing Luo, "Design of Circular Polarization Antenna With Harmonic Suppression for Rectenna Application," *IEEE Antennas Wireless Propag. Lett.*, Vol. 11, pp. 592-595, 2012.
- [12] Yu-Jiun Ren, Muhammad F. Farooqui, and Kai Chang, "A Compact Dual-Frequency Rectifying Antenna With High-Orders Harmonic Rejection," *IEEE Trans. Antennas Propagat.*, Vol. 55, No. 7, pp. 2110-2113, Jul. 2007.
- [13] Tae-Ui Hong, Kyoung- Min Oh, Hyun-Wook Lee, Hee Nam, Tae Soon Yun, Dae-Sung Lee, Hak-In Hwang, and Jong-Chul Lee, "Novel Broadband rectenna using printed monopole antenna and harmonic suppressed stub filter," *Microw. Opt. Technol. Lett.*, Vol. 52, No.5, pp. 1194-1197, May, 2010
- [14] C. A. Balanis, "Antenna Theory, Analysis and Design," *John Wiley & Sons. Third Edition*, New York, 2005.
- [15] Advanced Design System (ADS) : <http://www.home.agilent.com/agilent/home.jsp>
- [16] Tae-Wan Yoo and Kai Chang " Theoretical and Experimental Development of 10 and 35 GHz Rectennas " *IEEE Transactions On Microwave Theory And Techniques*, Vol. 40, No. 6. June 1992.
- [17] "Surface mount RF Schottkybarrier diode HSMS-282X series," Agilent Technol., Palo Alto, CA, Tech. Data, 2001.

BIOGRAPHIES OF AUTHORS



Taybi Abdellah was born in Tafrouit, Morocco, in September 1989. He received the master degree in electronic aviation safety from the International Academy Mohamed 6 of Civil Aviation, Morocco. He is currently working toward the Ph.D. degree in physics and engineering sciences at Faculty of Sciences and Technologies, Settat, Morocco. His research interests include the analysis and design of rectenna systems for wireless power transmission applications.



Abdelali Tajmouati was born in, Morocco, in 1962. He received the Ph.D. degree in science engineering from the University of Perpignan, France, in 1992. He is currently an associate Professor of Electronics, thermal transfer and thermodynamic in Faculty of sciences and techniques University Hassan 1st, Settat, Morocco. He is involved in the design of hybrid, monolithic active and passive microwave electronic circuits.



Jamal Zbitou was born in Fes, Morocco, in June 1976. He received the Ph.D. degree in electronics from Polytech of Nantes, the University of Nantes, Nantes, France, in 2005. He is currently an associate Professor of Electronics in FST, University Hassan 1st, Settat, Morocco and the head of Computing Networks and telecommunication in LMEET Laboratory in FSTS. He is involved in the design of hybrid, monolithic active and passive microwave electronic circuits.



Ahmed Errkik was born in July 1960 in Morocco. He received the Ph.D. degree in physics from the University of Technology Compiègne (UTC), Compiègne, France. He is currently an associate Professor of physics in FST University Hassan 1st, Settat, Morocco. He is involved in the design of hybrid, monolithic active and passive microwave electronic circuits.



Mohamed Latrach (IEEE member) received the Ph.D. degree in electronics from the University of Limoges, Limoges, France, in 1990. He is currently Professor of microwave engineering with the Ecole Supérieure d'Electronique de l'Ouest (ESEO), Angers, France, where he is head of the Radio-Frequency & Microwave research group. His research interests include: design of hybrid & monolithic active and passive microwave circuits, metamaterials, LH materials, antennas, rectennas and their applications in wireless communications, and wireless power transmission (WPT).