

A mitigation of channel crosstalk effect in dispersion shifted fiber based on durability of modulation technique

Ali Shaban¹, Murad Obaid Abed², Ehab Abdul Razzaq Hussein³, H. J. Abd⁴

¹Department of Biomedical Engineering, University of Babylon, Iraq

^{2,3,4}Department of Electrical Engineering, University of Babylon, Iraq

Article Info

Article history:

Received Apr 3, 2019

Revised Sep 11, 2019

Accepted Sep 27, 2019

Keywords:

FWM crosstalk

MDRZ

Modulation formats

RZ

WDM system

ABSTRACT

In fiber optics the Four Wave Mixing (FWM) has the harmful effect of an optical transmission system that can severely limit Wavelength Division Multiplexing (WDM) and reduce the transmission aptness. This work preset the durability of the different modulation format was tested to FWM by using Dispersion Shifted Fiber (DSF). Moreover, the performance of the proposed system is surveyed by changing the fiber length and applying an information rate of 200 Gb/s. The experimental results show that the FWM capacity has decreased significantly by more than 14 dB when applying Return to Zero (RZ) modulation form. In addition, in terms of the proposed system performance in the first channel and with 700 km distance, it was observed that the lower Bit Error Rate (BER) in the normal RZ modulation is equal to 1.3×10^{-13} . As well as it is noticeable when applied the Non Return to Zero (NRZ), the Modified Duobinary Return to Zero (MDRZ) and Gaussian modulation, the system performance will be quickly changed and getting worse, where the BERs increased to 1.3×10^{-4} , 1.3×10^{-6} and 1.3×10^{-2} consecutively at same channel and for the same parameters.

Copyright © 2020 Institute of Advanced Engineering and Science.
All rights reserved.

Corresponding Author:

Ehab AbdulRazzaq Hussein,
Department of Electrical Engineering,
University of Babylon,
Hillah-Najaf Road, Babylon, Iraq.
Email: dr.ehab@itnet.uobabylon.edu.iq

1. INTRODUCTION

With the fast development of telecommunication services, the needing for large capacity transmission has been increased. Therefore, dense wavelength-division multiplexing systems may be a suitable approach to cover these demands [1-3]. For WDM systems and in the presence of high bit rate per channel, the obstacle consequences of dispersion together with nonlinearity have to be managed to accomplish transmission through each valuable distance. Nonlinear effects are one of the most optical transmission system restrictions. When the total light power in a fiber is increased, the nonlinear effect becomes uncontrolled and may affect signal efficiency and degrade system performance [4]. One of the main factors that may cause interference in transmission systems, where there are channels are arranged to separate them from similar distances, is called the FWM. For optical communication systems, suppressing FWM efficiency is the main objective. A few methods were done to mitigate the defect of FWM efficiency and also modify the signal output [5-14].

Dispersion compensation techniques using fibers with opposite dispersion values are a crucial method in which the whole cumulative dispersal will be kept low. In these techniques, it employs Single-Mode Fiber (SMF) with Dispersion Compensation Fiber (DCF), the largest negative value of dispersal of DCF enable us to neutralize the positive dispersal of SMF [15, 16]. In standard transmission distances, the RZ and NRZ modulation forms are in most cases employed. The experiments and surveys have offered

that RZ takes into account to be top priority relative to the normal NRZ systems, as long as typical single-mode fibers are utilized as communication media [17, 18]. Whereas, due to the narrower optical spectrum of the NRZ format, NRZ can achieve higher spectral efficiency in WDM systems in comparison to RZ in the linear pattern. Recently, methods of optical multiplexing and demultiplexing with the combination of delay lines are one of the considerable various FWM suppression methods [19], In addition, the use of polarization technique and the technique of space between the channels contributed to reduce interference with the signals transmitted to some extent [20-23]. For all techniques done, the level of FWM crosstalk on the main channels still not much suppressed and thus the system efficiency stays low and must be improved. The features of FWM are very connected with the modulation forms. Under high data rate effect, FWM crosstalk will change and depend on the immunity of modulation formats. This work presents the durability of NRZ, RZ, MDRZ and Gaussian modulation to the FWM nonlinear under high data rate of 200 Gb/s. The suggested system design was implemented with different transmission distances and input signal power around 12 dBm.

2. MOSELING AND PROPOSED SYSTEM DESIGN

Figure 1 clarifies the proposed system design. The transmitter and receiver are the two basic elements which the suggested system design is made up from. To produce the carrier signal at the transmitter component, the continual wave laser layout (L1–L4) is employed. The frequency of first channel is adjusted to 191.5 THz, and the interval between every channel and another is 100 GHz. Every channel is modulated with 50Gb/s Bit rate. The external modulator consists of NRZ, MDRZ, RZ and Gaussian transmitter circuits.

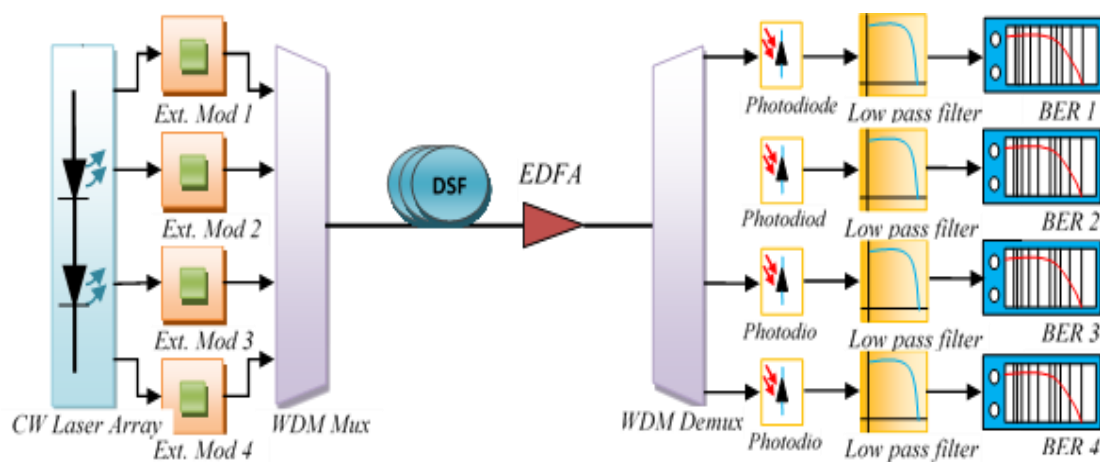

Figure 1. Proposed system design of NRZ, MDRZ and RZ

The transmitter system configuration of every modulation utilized is illustrated in Figure 2. At the point, an intensity modulator called Mach Zehnder Modulator (MZM) is connected to the transmitter system. Seven spans that the optical link includes. Also, each span is consists of Dispersion Shifted Fiber and follow it by optical fiber amplifiers, which own noise figure, magnitude of 5dB and gains of 20 dB. When the signal communicates by the channel of the optical fiber, the signal will be detected and obtained at the receiver. An Avalanche Photo Diode (APD) is used to detect the signal to obtain a direct detection. From that point, it is transmitted by the low-pass Bessel filter. The BER analyzer is directly connected to the electrical filter is utilized to produce the diagram. Table 1 illustrates the system simulation parameters.

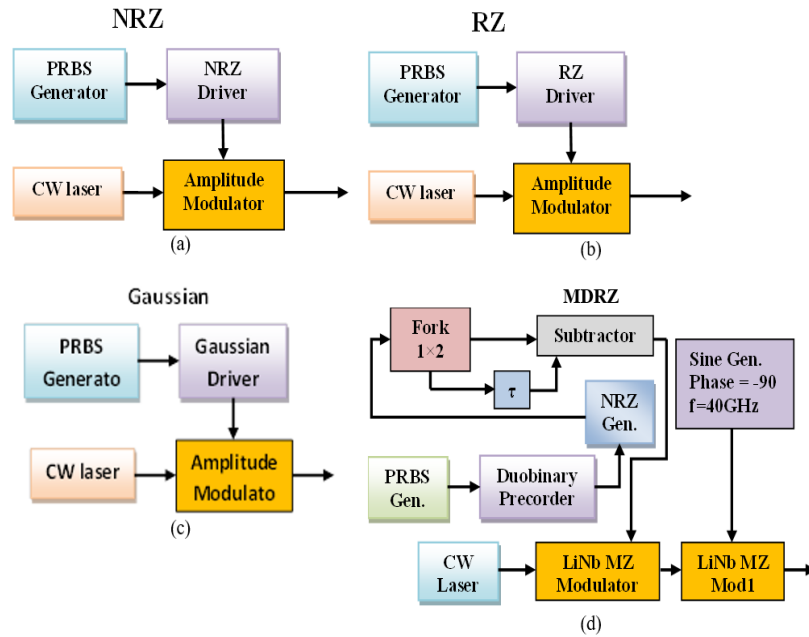

Figure 2. Proposed block diagram of optical transmitter for: (a) NRZ, (b) RZ, (c) Gaussian and (d) MDRZ

Table 1. Parameters specifications of optical transmission system

Parameter	Unit	Values
Input power, P_i	dBm	12
Number of channel, N_c	--	4
Total data rate, B	Gb/s	200
Input frequencies, F_{in}	(THz)	191.5 -191.8
Channel Spacing, Δf	(GHz)	100
Fiber Parameters		
Fiber type	DSF G.653	
Length of fiber, L	Km	100 to 700
Fiber dispersion, D_c	ps/nm.km	0.3
Dispersion slope	ps/nm ² .km	0.075
Cross effective area, A_{eff}	μm^2	50
Degeneracy factor, D	---	6
Third order Susceptibility, X_{111}	m ³ /w.s	6×10^{-15}
Refractive index	n	1.48

The thermal along with shot noises are occurring, the probability distribution functions will be Gaussian act. The significant issue which is seen that the FWM commotions have likelihood circulation probability isn't Gaussian. This issue is causing disturbance on both thermal with shot noises [24]. Optical amplifier noise is deemed as well. The interference between amplified spontaneous emission (ASE) noise and FWM noise is ignored [25]. In the Gaussian estimation the error probability is written as [24]:

$$P_e = \frac{1}{\sqrt{2\pi}} \int_Q^\infty \exp\left(-\frac{t^2}{2}\right) dt. \tag{1}$$

with

$$Q = \frac{K P_s}{\sqrt{N_{th} + N_{sh} + N_{amp} + 2K^2 P_s^2 C_{IM}^{(m)} + \sqrt{N_{th}}}}. \tag{2}$$

where:

$$K = \frac{\eta_a e}{hf}. \tag{3}$$

$$P_s = GL_t P_1. \tag{4}$$

$$N_{th} = \frac{Q_0^2}{4} \left(\frac{KP_{so}}{Q_0^2} - \Re \right)^2. \quad (5)$$

$$N_{sh} = \Re KP_s. \quad (6)$$

$$N_{amp} = k_a K^2 (G - 1)(m + 1)L_t P_s. \quad (7)$$

$$k_a = 4n_{sp} h f B_f. \quad (8)$$

$$C_{IM}^{(m)} = \frac{1}{8} \sum_{p \neq q \neq r \neq s} \frac{P_{pqr}}{P_s} + \frac{1}{4} \sum_{p \neq q \neq r = s} \frac{P_{pqs}}{P_s} + \frac{1}{4} \sum_{p = q \neq r} \frac{P_{ppr}}{P_s}. \quad (9)$$

Here, $C_{IM}^{(m)}$ is the crosstalk components of the FWM, P_s is the signal light peak power received, N_{th} is the power of thermal noise, N_{sh} is the power for shot noise, N_{amp} is the noise power for optical amplifier. η_d is the detector quantum efficiency, e is the electric charge, h is Planck's constant, and f is the light frequency. G is the gain of optical pre-amplifier, m is the nodes number, L_t is the optical pre-amplifier coupling loss, and P_I is the input power into the pre-amplifier in channels one. In this work, Q_0 is a Q value corresponding to a required BER, P_{so} is the signal light peak power received for a required BER with neither FWM nor ASE, and $\Re = 2e B_f M x$ where B_f is the bandwidth of electrical filter, M is the factor of APD current multiplication, and x is the excess noise factor of APD. Where the receiver parameters are $B_f = 10$ GHz; $M = 15$, and $x = 0.7$ [24]. Where supposed that a quantum efficiency η_d of 85% is taken for an APD into consideration [26]. In random RZ, the bandwidth will be double compared to NRZ and both P_{pqr} and P_{pqs} will multiply by probability (0.25), and P_{ppr} multiply by probability (0.5), where the total probability of all FWM components equal to (1).

$C_{IM}^{(m)}$ is replaced by $C_{RRZ}^{(m)}$ as follows:

$$C_{RRZ}^{(m)} = \frac{1}{4} \cdot \frac{1}{8} \sum_{p \neq q \neq r \neq s} \frac{P_{pqr}}{P_s} + \frac{1}{4} \cdot \frac{1}{4} \sum_{p \neq q \neq r \neq s} \frac{P_{pqs}}{P_s} + \frac{1}{2} \cdot \frac{1}{4} \sum_{p \neq q \neq r} \frac{P_{ppr}}{P_s}. \quad (10)$$

In terms of NRZ modulation the FWM crosstalk will become as:

$$C_{NRZ}^{(m)} = \frac{1}{8} \sum_{p \neq q \neq r \neq s} \frac{P_{pqr}}{P_s} + \frac{1}{4} \sum_{p \neq q \neq r \neq s} \frac{P_{pqs}}{P_s} + \frac{1}{4} \sum_{p \neq q \neq r} \frac{P_{ppr}}{P_s}. \quad (11)$$

$$P_s = -\frac{Kk_a(G-1)L_t(m+1)+\Re}{K(4C_{IM}^{(m)}-1/2Q^2)} + \frac{\sqrt{[Kk_a(G-1)L_t(m+1)+\Re]^2 - N_{th}K(8C_{IM}^{(m)}-1/Q^2)}}{K(4C_{IM}^{(m)}-1/2Q^2)}. \quad (12)$$

$$Q = \frac{KP_s}{2\sqrt{N_{th}+N_{sh}+N_{amp}+2K^2P_s^2C_{IM}^{(m)}}}. \quad (13)$$

3. RESULT ANALYSIS AND DISCUSSIONS

In this section, the fiber length effect on FWM power with four modulation, pulse types which are NRZ, MDRZ, RZ and Gaussian was evaluated. The system performance is simulated in terms of BER among modulation formats mention.

3.1. Averaged FWM crosstalk

System simulation was performed by increasing the fiber length values from 100 to 700 km, i.e., seven spans; with available simulations for all modulations. Figure 3 explains the FWM versus transmission distance variation under 200Gb/s. An increase in the transmission distance can increase the FWM crosstalk on the channel and thus decrease the optical system efficiency. At low values of transmission distance, the nonlinear effect has a little effect on system performance i.e. FWM was low. When the power of the channel increase the crosstalk will appear stronger and impairment the transmission system because it causes depletion of the channel power.

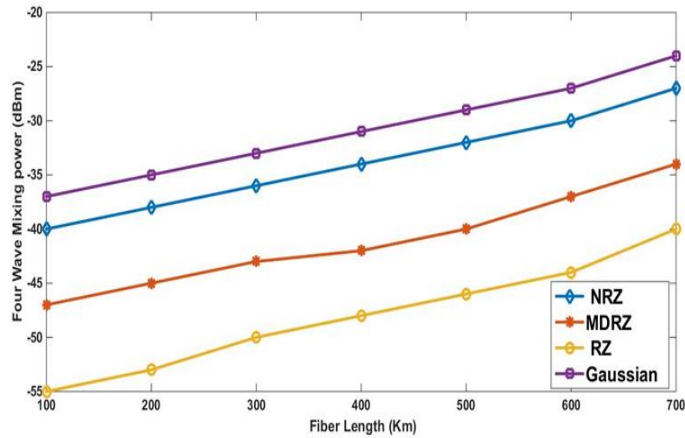

Figure 3. FWM power versus fiber length variation for different modulation

Figure 4(a-d) shows the optical spectrum of 700 km optical fiber. It is obvious from this figure that the FWM power was high and reaches to -24 dB in Gaussian modulation format, while the availability of both MDRZ and RZ modulation, the FWM powers were dropped to -34 and -40dBm respectively. This means that RZ modulation appears better to tolerate to FWM crosstalk compared to its competitors.

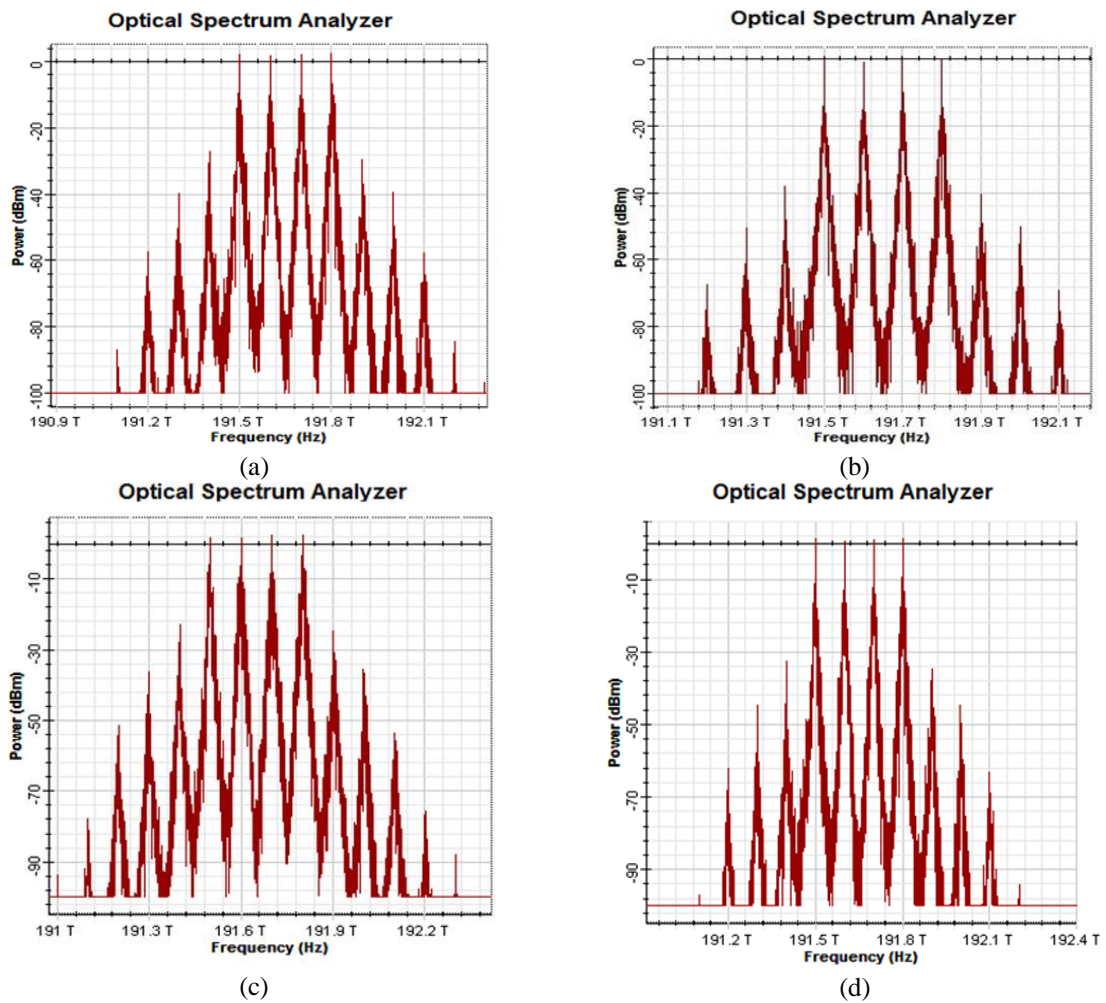

Figure 4. Optical spectrum analyzer after 700 km distance with modulation format types: (a) NRZ, (b) RZ, (c) Gaussian and (d) MDRZ

3.2. Bit error rate and eye diagram

Figure 5 explains the relation between the fiber lengths versus BER under data rate influence of 200 Gb/s. The system performance has been performed by using single mode fiber (SMF) and for three modulation types used. It can be seen that as an increment in the transmission distance lead to increase the bit error rate in the system. The trend of the system performance was similar to all channels used i.e the RZ reveals better system performance. It is observed from Figure 5(a), in the first channel, the RZ modulation technique offered a minimum BER of 1.3×10^{-13} at transmission distance of 700 km. However, with NRZ, MDRZ and Gaussian modulation, pulse, the BERs were 1.3×10^{-4} , 1.3×10^{-6} and 1.3×10^{-2} respectively at the same channel and fiber length.

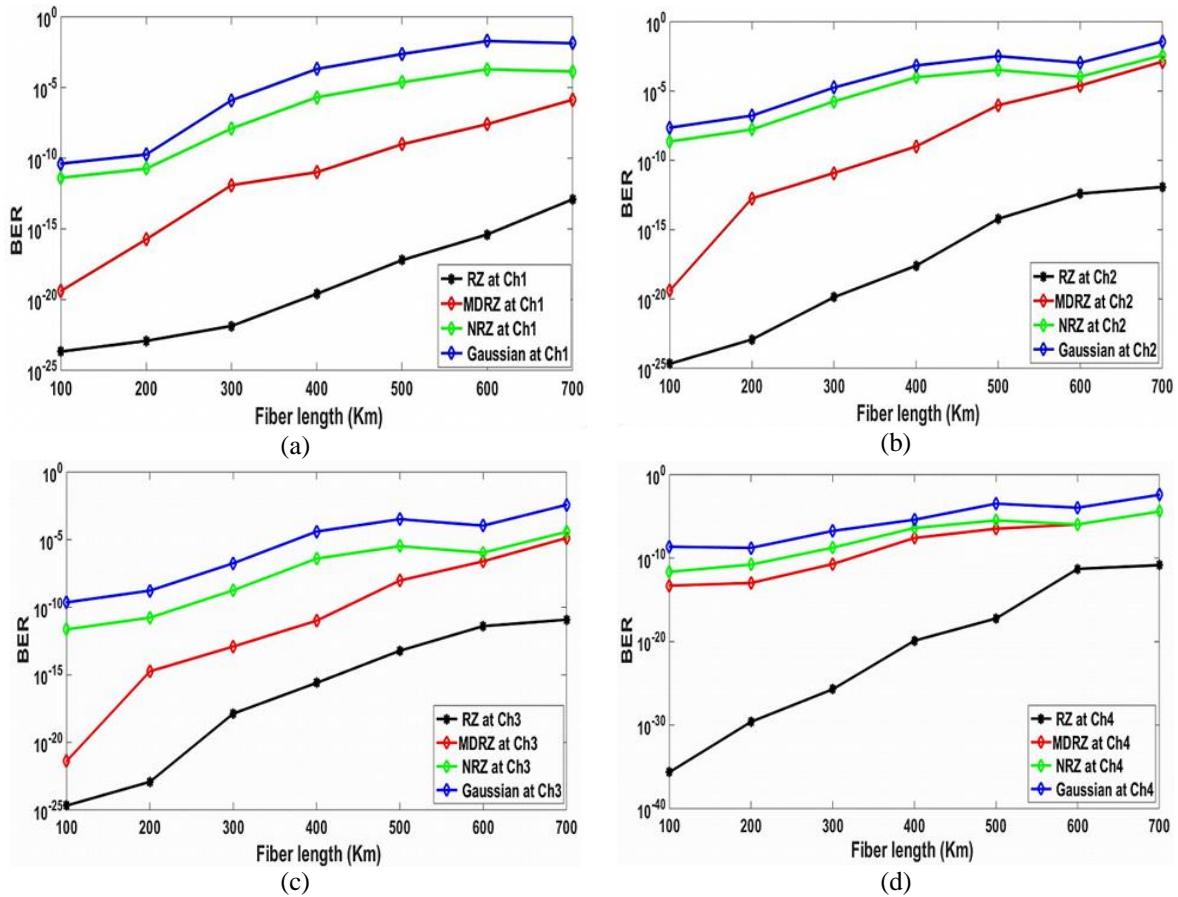

Figure 5. BER versus fiber length for modulation technique of (a) Ch1, (b) Ch2, (c) Ch3 and (d) Ch4

More importantly, it can be concluded from the modulation behavior with high values of both data rate and distance, that RZ modulation reveals more adequacy to nonlinear effect than NRZ and MDRZ. Figure 6 shows that the optimum eye diagram for all modulation used after 700 km and measured at the first channel. The optimum eye diagram was the height with RZ modulation of BER (1.2×10^{-13}). Inversely with NRZ and Gaussian modulation, where the eye diagram was less clarity and high of BERs (1.3×10^{-4}) and (1.3×10^{-2}) consequently on same channel. More opening eyes diagram means that the RZ modulation has high firmness to nonlinear effect in high data rate, also improving in the succeeding rate of receiving bits (1 and 0) detection with little defect or no noise due to the overlapping.

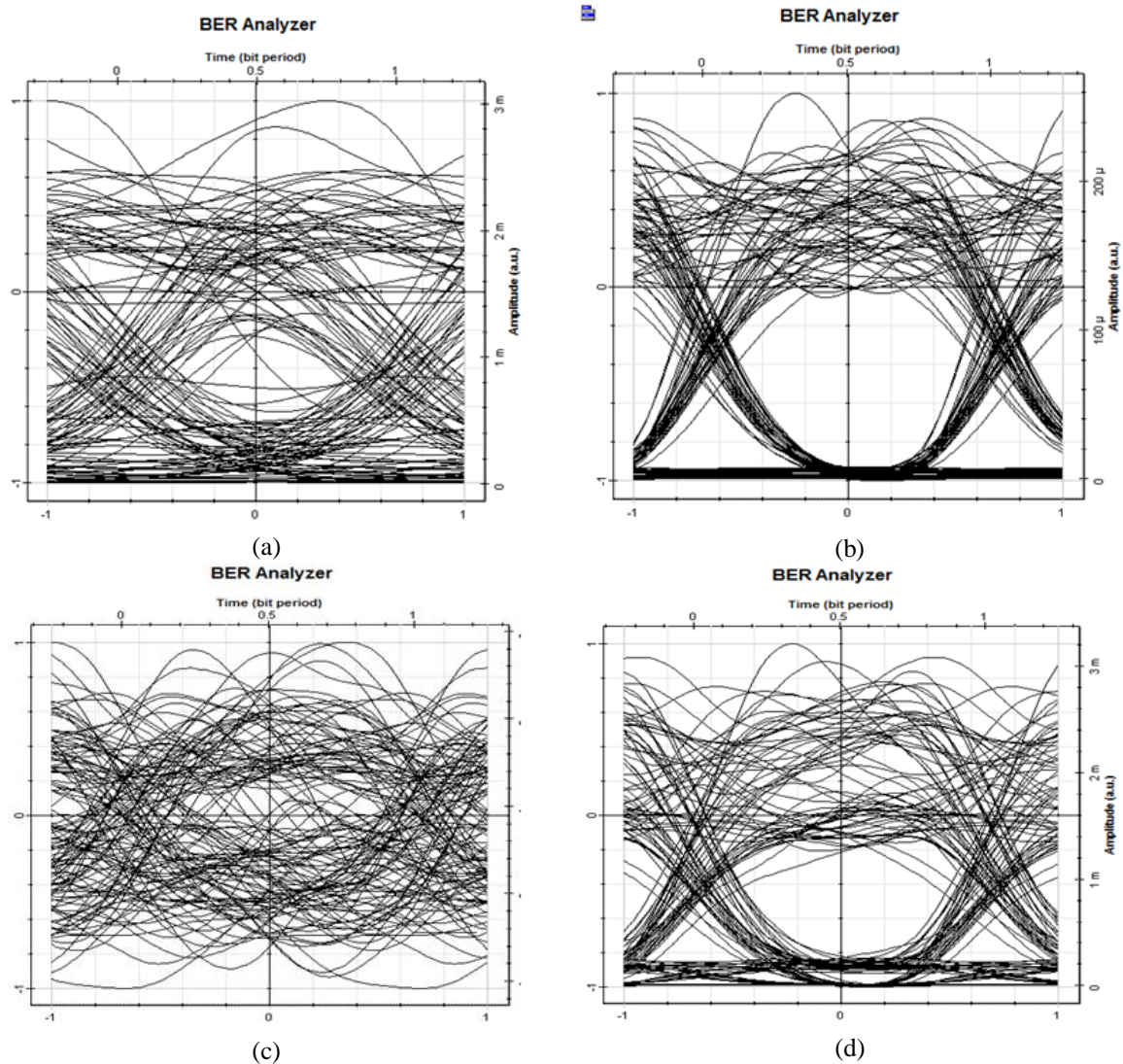

Figure 6. Eye diagram of modulation technique using (Ch1): (a) NRZ modulation, (b) RZ modulation, (c) Gaussian modulation and (d) MDRZ modulation

4. CONCLUSION

This work provides a complete analysis of optical transmission performance under the influence of fiber length tuning and the use of high data rate with NRZ, RZ, MDRZ and Gaussian. Experimental results show that FWM power is suppressed by more than 14 dB through the proposed RZ modulation procedure. For BER in the first channel, RZ offers the lowest BER rate of (1.2×10^{-13}) at a distance of 700 km of fiber compared to the other configurations used. Finally, we can conclude that the RZ adjustment provides more robustness for crosstalk routing even with high value data rate.

REFERENCES

- [1] M. H. C. Hansen, *et al.*, "Demonstration of 5.1 Tbit/s Data Capacity on a Single Wavelength Channel," *Opt Express*, vol. 18, pp. 1438-1443.
- [2] M. H. C. Hansen, *et al.*, "1.28 TBIT/s single-Polarisation serial OOK Optical Data Generation and Demultiplexing," *Electron Lett*, vol. 45, pp. 280-281, 2009.
- [3] S. N. Shahiand and Kumar S., "Reduction of Nonlinear Impairments in Fiber Transmission System Using Fiber and/or Transmitter Diversity," *Opt. Commune.*, vol. 285, pp. 3553-3558, 2012.
- [4] T. Shimizu, *et al.*, "Evaluation Methods and Requirements for The Stimulated Brillion Scattering Threshold in a Single-Mode Fiber," *Optic. Fiber Technology*, vol. 14, pp. 10-15, 2008.
- [5] H. J. Abed, *et al.*, "Recent four-Wave Mixing Suppression Methods," *Optik*, vol. 124, pp. 2214-2218, 2013.

- [6] H. J. Abd, *et al.*, "Priority-Based Parameter Optimization Strategy for Reducing the Effects of Four-Wave Mixing on WDM System," *Optik*, vol. 125, pp. 25, 2014.
- [7] H. Abd, *et al.*, "Four-wave Mixing Crosstalk Suppression Based on the Pairing Combinations of Differently Linear-Polarized Optical Signals," *Sci. World J.*, vol. 2014, pp. 1, 2014.
- [8] H. J. Abd, *et al.*, "Four-wave Mixing Reduction Technique Based on Smart Filter Approach," *International Journal of Electronics*, vol. 102, pp. 1056-1070, 2015.
- [9] H. J. Abed, *et al.*, "Comparison Among Different Types of Advanced Modulation Formats Under Four Wave Mixing Effects," *Ukrainian Journal of Physics*, pp. 326-334, 2013.
- [10] H. J. Abd and M. S. Almahanna, "Suppression of Nonlinear Effect for High Data Transmission Rate with a WDM Using the Optimization Properties," *Ukrainian Journal of Physics*, vol. 62, pp. 583-588, 2017.
- [11] N. Salim, *et al.*, "Four-Wave Mixing Suppression Method Based on Odd-Even Channels Arrangement Strategy," *Progress In Electromagnetics Research*, vol. 66, pp. 163-172, 2018.
- [12] H. J. Abd, *et al.*, "Mitigation of FWM crosstalk in WDM system Using Polarization Interleaving Technique Photonics (ICP)," *2013 IEEE 4th International Conference on*, pp. 117-119, 2013.
- [13] H. J. Abed, *et al.*, "A new FWM Reduction Technique Based on Damping Selective Wavelengths," pp. 957-962.
- [14] A. H. Jabber, *et al.*, "Influence of four wave mixing on modulation format performance under 100 Gb/s data rate Research and Development (SCORED)," *2012 IEEE Student Conference on*, pp. 129-133, 2012.
- [15] G. P. Agrawal, "Nonlinear Fiber Optics," *Academic Press*, New York, 2001.
- [16] G. P. Agrawal, "Applications of Nonlinear Fiber Optics," *Academic Press*, New York, 2001.
- [17] M. I. Hayee and A. E. Willner, "NRZ Versus RZ in 10–40-Gb/s Dispersion Managed WDM Transmission Systems," *IEEE Photonics Technol. Lett.*, vol. 11, pp. 991-993, 1999.
- [18] G. Bosco, *et al.*, "On the use of NRZ, RZ, and CSRZ Modulation at 40 Gb/s with narrow DWDM channel spacing," *J. Lightwave Technol.*, vol. 20, pp. 1694, 2002.
- [19] A. Hodzik, *et al.*, "Alternative Modulation Formats in N_40 Gb/s WDM Standard Fiber RZ-Transmission Systems," *IEEE J. Lightwave Technol.*, vol. 20, pp. 598, 2002.
- [20] D. Dahan and G. Eisenstein, "Numerical Comparison Between Distributed and Discrete Amplification In a Point-to-Point 40-Gb/s 40-WDM-Based Transmission System with Three Different Modulation Formats," *J. Lightwave Technol.*, vol. 20, pp. 379, 2002.
- [21] R. S. Kaler, *et al.*, "Simulation Results for DWDM Systems with Ultra-High Capacity," *Int. J. Fiber Integrated Opt.*, vol. 21, 2002.
- [22] P. J. Winzer and R. J. Essiambre, "Advanced Optical Modulation Formats," *Proceedings of the IEEE*, vol. 94, pp. 952-985, 2006.
- [23] S. Singh and R. S. Kaler, "Simulation of DWDM Signals Using Optimum Span Scheme with Cascaded Optimized Semicon-Ductor Optical Amplifiers," *Optik—Int. J. Light Electron. Opt.*, vol. 118, pp. 74-82, 2007.
- [24] K. Inoue, *et al.*, "Crosstalk and Power Penalty Due to Fiber Four-Wave Mixing in Multichannel Transmissions," *J. Lightwave Technol.*, vol. 12, pp. 1423, 1994.
- [25] S. P. Singh, *et al.*, "Performance of All-Optical WDM Network in Presence of Four-Wave Mixing, Optical Amplifier Noise, and Wavelength Converter Noise," *Fiber and Integrated Optics*, vol. 26, pp. 79-97, 2007.
- [26] K. Ema, *et al.*, "All Optical Sub Tbits/s Serial to Parallel Conversion Using Excitation in Giant Nonlinearity," *Appl. Phys. Lett.*, vol. 59, pp. 2799, 1991.

BIOGRAPHIES OF AUTHORS



Ali Shaban Hassooni, MSc. Electrical Engineering was born in Babylon on July 7, 1981. He obtained his BSc degree (2003) in Electrical Engineering at the Faculty of Engineering, University of Babylon and MSc degree (2011), in electronic and communication engineering at the Department of Electrical Engineering, University of Babylon, Currently he works at the Biomedical Department at the Faculty of Engineering, University of Babylon. His main interest is medical signal processing, Microcontroller systems, Biomedical sensors and control system analysis.



Mr. Murad Obaid Abed earned his MSc. in the field of Electrical Engineering from university of technology, Iraq, 2002. He has more than five years of experience in teaching. He completed his BSc in Electrical Engineering, University of Technology, Baghdad, Iraq, 1983. His research interests include communication, wavelet transform, electronic system design and Quantum communication.



Ehab AbdulRazzaq Hussein, PhD. & MSc. Electrical Engineering was born in Babylon on January 1, 1976. He obtained his BSc degree (1997) in Electrical Engineering at the Faculty of Engineering, University of Babylon and MSc degree (2000), in electrical engineering at the Department of Electrical Engineering, University of Technology and his PhD. Degree from the Department of Electrical Engineering at the Faculty of Engineering, University of Basrah. Currently he works as assistant professor at the Electrical Department at the Faculty of Engineering, University of Babylon. His main interest is signal processing, analysis, information transition, sensors and control system analysis.



Associate professor Dr. Haider J. Abd earned his Ph.D. in the field of Electrical Engineering from university of Tenaga Nasional, Malaysia, 2014. He has more than ten years of experience in teaching. He completed his MSc, in Electrical Engineering, university of Baghdad, Baghdad, Iraq, 2005. His research interests include Optical fiber communication, Wireless communication, Digital signal processing, smart systems, Biomedical Engineering, Maglev system and Adaptive control system.