



FETAL MOVEMENTS RECORDING SYSTEM USING ACCELEROMETER SENSOR

Nor Diana Zakaria¹, Paulson Eberechukwu Numan² and M. B. Malarvili¹

¹Faculty of Biomedical Engineering, Universiti Teknologi Malaysia, Johor Bahru, Malaysia

²Faculty of Electrical Engineering, Universiti Teknologi Malaysia, Johor Bahru, Malaysia

E-Mail: malarvili@biomedical.utm.my

ABSTRACT

One of the compelling challenges in modern obstetrics is the monitoring fetal wellbeing. Physicians are gradually becoming cognizant of the relationship between fetal activity, movement, welfare, and future developmental progress. Previous works have developed few accelerometer-based systems to tackle issues related to ultrasound measurement, the provision of remote support and self-managed monitoring of fetal movement during pregnancy. Though, many research questions on the optimal setup in terms of body-worn accelerometers, as well as signal processing and machine learning techniques used to detect fetal movement, are still open. In this work, a new fetal movement system recorder has been proposed. The proposed system has six accelerometer sensors and ARDUINO microcontroller. The device which is interfaced with the MATLAB signal process tool has been designed to record, display and store relevant sets of fetal movements. The sensors are to be placed on the maternal abdomen to record and process physical signals originating from the fetal. Comparison of data recorded from fetal movements with ultrasound and maternal perception technique gave the following results. An accuracy of 59.78%, 85.87%, and 97.83% was achieved using the maternal perception technique, fetal movement recording system, and ultrasound respectively. The findings show that the proposed fetal movement recording system has a better accuracy rate than maternal perception technique, and can be compared with ultrasound.

Keywords: fetal movements, accelerometer sensor, ARDUINO, MATLAB.

1. INTRODUCTION

Fetal movement (FM) in the uterus is an expression of fetal well-being that depends mainly on the vascular state of placental insufficiency [1]. The movement otherwise known as “kicking” by the maternal perception [2] starts from the fourth month of pregnancy. Its signs include activities such as sleeping, waking up, swallowing, and passing urine. FMs become obvious during the third trimester. During this period, the fetal exhibits more clearly prolonged periods of FMs. The fetal becomes more active at certain times of the day and starts to adapt to a more regular sleep-wake cycle [3]. Fetal has a peculiar style with respects to FMs. It is very important to monitor the fetal health. The growth of the fetal in the uterus needs to be monitored as it rapidly changes every week. Monitoring FMs not only involves counting the number of movements but also getting to know what is going into the uterus and the typical pattern of their FMs [4]. There is a need to continuously monitor the FM as it benefits both the woman and fetal in so many ways. Particularly, in the third trimester, the fetal are more active at certain times of the day as they begin to adapt to a more regular sleep-wake cycle. They exhibit more clearly prolonged periods of FMs during the third trimester [3]. FMs have been widely used to represent fetal well-being in a simple manner and can be easily understood [5, 6]. Maternal have to monitor FMs because the spontaneous movements by fetal are the fundamental expressions of early neural activity [7]. These movements’ help to ascertain if the fetal is in a good condition or would need external monitoring/help. There is need to take extra cautions on the condition of fetal since they are fragile and can be worsened if not being treated earlier. Routine FMs monitoring can help to define the normal patterns of the

fetal, thus making it easier to predict decreased fetal movements (DFM).

There are several techniques and devices used to monitor the fetal depending on cases. Maternal perception technique is among the techniques that do not require any cost or technology, which plays its role in counting the FMs. This technique is commonly used in daily routine to monitor the fetal condition. In the clinic, devices used to monitor fetal depend on their cases. For the appointment routine with gynecology, an ultrasound machine is utilized to observe fetal condition and physically measure their growth. Apart from that, CTG is used to monitor fetal heartbeat for cases related with DFM. The oldest and most commonly used method to assess fetal well-being is the maternal perception. The maternal is instructed to record FMs at least 10 movements within 2 hours every day [8]. They preferably count it at the same time every day. A decrease in the number of movements may indicate unhealthy fetal [1]. The maternal perception method requires no cost and technology and is measured as an instructor screening to which almost all pregnant women adhere. Many women who have delivered a live born baby would agree that it is important to feel the FMs every day. They will immediately find a health care provider when they screened themselves positive for DFM with the expectation of further evaluations to keep their fetal healthy [9]. Measuring FMs allows the clinicians to predict the condition and development of fetal. In the clinic, they use an active method to check on fetal development. This method uses a device such as ultrasound with signal/wave penetration to the fetal to monitor FMs. Ultrasound is using sound wave that transmits energy to the maternal body for detection. However, ultrasound is expensive with several objections for a long-term usage



[10]. The side effects of long-term ultrasonic exposure on the fetal and young infants are yet to be revealed, which became the reason why this ultrasound method is not recommended for long monitoring [11]. Several researchers have verified the relationship between fetal heart rate acceleration and FMs to represent the physiological state of the fetal [12-14]. For instance, a study by [15] on 166 patients evinced that both fetal heart rate acceleration and FMs can be used as indicators for fetal well-being. When the heart beats, it pumps oxygenated blood throughout the fetal and activates its muscles, resulting in muscle activity known as FMs that represents a healthy fetal.

Therefore, mothers who experience absence or decreased FMs are at risk of stillbirth as well as other adverse neonatal outcomes. The latest technology study uses accelerometer sensor to record FMs. The oscillation of maternal abdominal wall kick by the fetal can be detected using this accelerometer sensor [16-18]. This sensor is non-invasive, low cost, lightweight and does not require a trained operator suitable for home monitoring. Studies have been carried out on the effectiveness of accelerometer and its ability to sense thoroughly from the maternal abdominal wall [16]. Besides, other studies have used single accelerometer sensor, but with poor performance [18]. The limitation of data for a single sensor might be caused by the large area of the maternal abdominal wall. Therefore, this study aimed at undertaking the problems as discussed above and develop a new tool using more sensors for better accuracy. Thus, this work proposes a new prototype to measure FMs by using a sensor which does not harm both fetal and the maternal. Furthermore, few accelerometer-based systems have been developed by previous works to tackle issues related with ultrasound measurement, provision of remote support and self-managed monitoring of fetal movement during pregnancy. Though, many research questions on the optimal setup in terms of body-worn accelerometers, as well as signal process and machine learning techniques used to detect fetal movement, are still open. The proposed system has six accelerometer sensors and ARDUINO microcontroller. The device which is interfaced with MATLAB signal process tool has been designed to record, display and store relevant sets of fetal movements. The sensors are to be placed on the maternal abdomen to record and process physical signals originating from the fetal. Comparison of data recorded from fetal movements with ultrasound and maternal perception technique gave the following results. The rest of this paper is organized as follows; Section 2 provides a brief review on existing FM Systems in the market and sensors used in FM Monitoring System. Section 3 presents the experimental set-up and methodology. It explains the implementation of a method for analyzing FMs recording system. The findings and discussion of the results of the work have been given in Section 4. Finally, Section 5 gives some conclusions based on the results obtained in this study and recommends some directions for further study.

2. STATE OF THE ART

A. Existing FMs systems in the market

There are many types of system for monitoring the FMs. Among these systems is the phonocardiogram as shown in Figure-1. The phonocardiogram is applying acoustic transducer such as piezoelectric sensor. It can detect the fetal pulse, fetal heart beat and also fetal respiratory sound. The phonocardiogram monitoring is based on a passive acoustic technique, where no energy is transmitted to the fetus [19]. On the other hand, it has the potential for fetal monitoring during first and second trimesters as well as labor, and its usage as a secondary diagnosis tool. Also, the ultrasound is considered as a gold standard during pregnancy among existing technology. A prototype ultrasound machine is illustrated in Figure 2. The real-time ultrasound scanning lead to a reduction in mortality rate of the foetus [7]. The ultrasonic sensor transmits energy wave through the maternal body in order to gain the signal and display the image on the screen.



Figure-1. The Phonocardiograph.



Figure-2. The ultrasound machine.

Figure-3 shows the block diagram of an FM monitor which has been patented by Wei, NA., Song, W. and Jiang, X. The design consists of a processor to record the FMs, alarm circuit for start and stop count also the display unit. The FM recorder uses a microcontroller as a control unit and a direct current power source to operate. It is also has a warning tone circuit composed by a triode and a buzzer for analarming sign. The device is convenient to operate, has high recording accuracy and has no side effect. Figure-4 also shows a more recent example of products that been successfully sold in the market. Based on the existing design, the important features and components in any FMs device should be asensor, processor, and adisplay unit. The next part of this section presents a detailed review of sensors used in FM monitoring system.

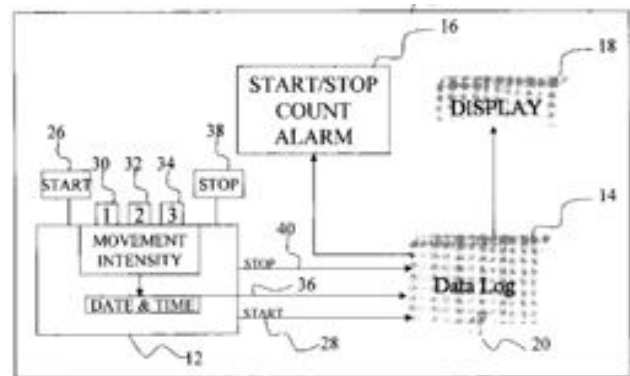

Figure-3. The block diagram.



Figure-4. Fetal movements recorder.

B. Sensors used in FM monitoring system

There is an increasing trend towards the use of devices synchronized with internet and smartphone applications. The device normally uses both active and passive types of sensor. These sensors are mostly used for pressure sensing, fetal movement and heart rate monitoring, uterine activity monitoring, ECG, FECG, and EMG. Most of them utilize wireless transmission methods and provide facility to listen and record fetal heart rate and other aspects. These devices can be considered under 'Internet of Things for Medical Devices'. Trends showed an increasing interest of companies, top performers towards sensors [20] with healthcare being one of the top ten sectors for the internet of things. Hence, there is an increasing need of introducing new, efficient sensors that do not lead to any abnormalities and give efficient readouts for measurement. Various sensors have been used to record FMs. Each of them has their own advantages and disadvantages. The list of some of the sensors, their advantages and disadvantages as reported in literature for monitoring FMs have been summarised in the Table-1. Accelerometer sensor has been used for this work. The use of the accelerometers constitutes a promising advancement in the automatic detection of FM, especially for long-term recordings. The low cost, lightweight, and non-intrusive system which is sensitive to small movements constitutes a viable alternative to ultrasound and may ultimately identify the at-risk fetus to allow timely clinical intervention.

**Table-1.** The type of sensors used FMs monitoring system.

Sensors	Advantages	Disadvantages
Moving Coil Transducer	The transducer is not affected by maternal respiration and uterine contractions.	It is not affected by slow movements, thus require an amplifier to receive the signals.
Strain-Gauge Transducer	The transducer is simple and safe	It responds to all abdominal movements.
Cantilevered piezoelectric crystal	The sensor is mounted within a contacting slab to have a natural frequency of approximately greater than 50 Hz.	The high sensitivity of sensors requires filtering method to ensure a smooth signal recording.
Phonocardiogram transducers	No harm for prolonged monitoring.	Not portable and it also measures fetal breathing.
The inductive transducer	The transducer has a large dynamic range suitable to the compliance of maternal abdominal wall to pass very weak acoustic signals.	Clashes with the requirement of wideband photography and there is a compromise between sensitivity and bandwidth.
Single Doppler Ultrasound Transducer	Provides a simple way to objectively measure the performance of any fetal motion detector.	By using one transducer, many limiting factors are detected.
Two Doppler transducers	A significant improvement over existing systems in detecting fetal using two Doppler transducers.	The sound wave transmitted to the young fetus might affect their tissues.
Accelerometer	The result outcome is highly in agreement with actual FMs signal recorded using maternal evaluation. A low-cost, passive, non-invasive system that does not require trained operators. It uses threshold method and detection method. The recorder has a higher sensitivity than maternal perception, but lesser compared to ultrasound. In most cases, it is able to record at home by the mother.	The signal is recorded using only two sensors. The method has room for improvement to increase its accuracy. The signal is recorded using two sensors only, so it cannot cover a wide area of maternal abdominal wall

3. METHOD

A. System overview

The block diagram for the proposed device is divided into three units. It consists of accelerometer sensors as the input, ARDUINO microcontroller as a processing unit and MATLAB Interface as the output unit. The hardware used for this work was constructed and the results were benchmarked with maternal perception and ultrasound in order to validate the hardware developed. A block diagram of the proposed FMs recording is shown in Figure-5. Details of each of the unit making up the FMs recording system described in the subsequent paragraphs.

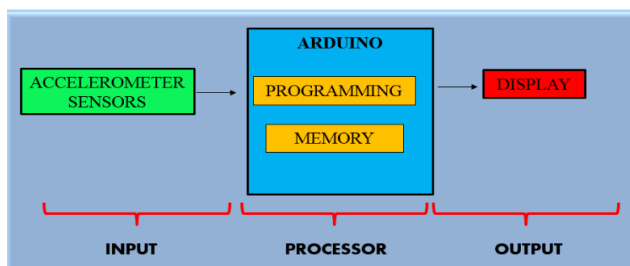

Figure-5. Block diagram of proposed FMs recording system.

B-1. Input: Accelerometer sensor

These accelerometer sensors were chosen as the input unit for this study because they are useful in a multitude of applications. The accelerometer is an electromechanical device used to measure acceleration forces. The forces may be static or dynamic. It is like the constant force of gravity pulling the feet. While dynamic force is caused by the movement or vibration of the accelerometer [21]. In this study, it is used to sense the dynamic movement of the fetal. Accelerometer with analog output was used in this study. The signal recorded from the accelerometer in analog output signal was being processed by an Arduino microcontroller. The sensors used are harmless to both the maternal and fetal. It does not transmit any signal that can affect fetal development as it is required for long hour monitoring [11]. In monitoring FMs, there is a clinical need for an accurate method over a long period, especially in late gestation. Preliminary findings have shown that accelerometers are useful advancement in detecting FMs in maternal abdominal, as it is sensitive even to small movement [5]. This work employed the use of more sensors to detect the FMs compared to the previous study were only two sensors were used [16]. Increasing the number of sensors make the coverage area wider and more effective. The sensors are used by attaching the sensors to the maternal abdominal wall. These sensors made can easily patch on abdominal



wall by the maternal themselves according to instructions given. The sensors also designed to continuously monitor the FMs overnight. Thus, it can be said that accelerometer-based systems in the future are able to replace maternal perception techniques and monitor the fetal in unsupervised free-living settings [22]. A typical 3-Axis accelerometer sensor is shown in Figure.

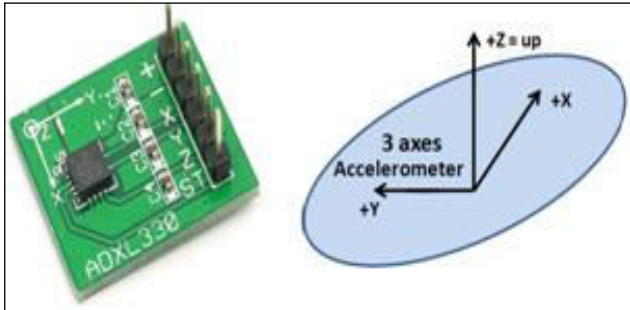

Figure-6. A typical 3-Axis accelerometer sensor.

B-2. Processor Unit: ARDUINO microcontroller

ARDUINO microcontroller was used in processing the analog inputs from the accelerometers as stated earlier. User-friendly software was designed to improve the accuracy of FMs measurement. It is developed to read the signals from sensors and display the result in real time using serial monitor. The data recorded are stored in an external memory card as a reference for clinicians if unexpected result or conditions of fetal occur. The ARDUINO microcontroller was used because it is an open-source platform. ARDUINO operates on very low DC voltages ranging from 6 to 20 volts, which makes it applicable in portable applications. The total current used is around 40 mA per input/output pin, which is relatively small compared to other microcontrollers. ARDUINO also has special features that allow serial communication with other devices including a computer. The flowchart in Figure-7 shows a detailed summary of the Arduino code developed in order to achieve this work. A continuous measurement was carried out for twenty minutes via the accelerometer sensor. The actual data recorded was sent to the ARDUINO serial monitor. A total of 120 000 samples were collected during the duration of each measurement.

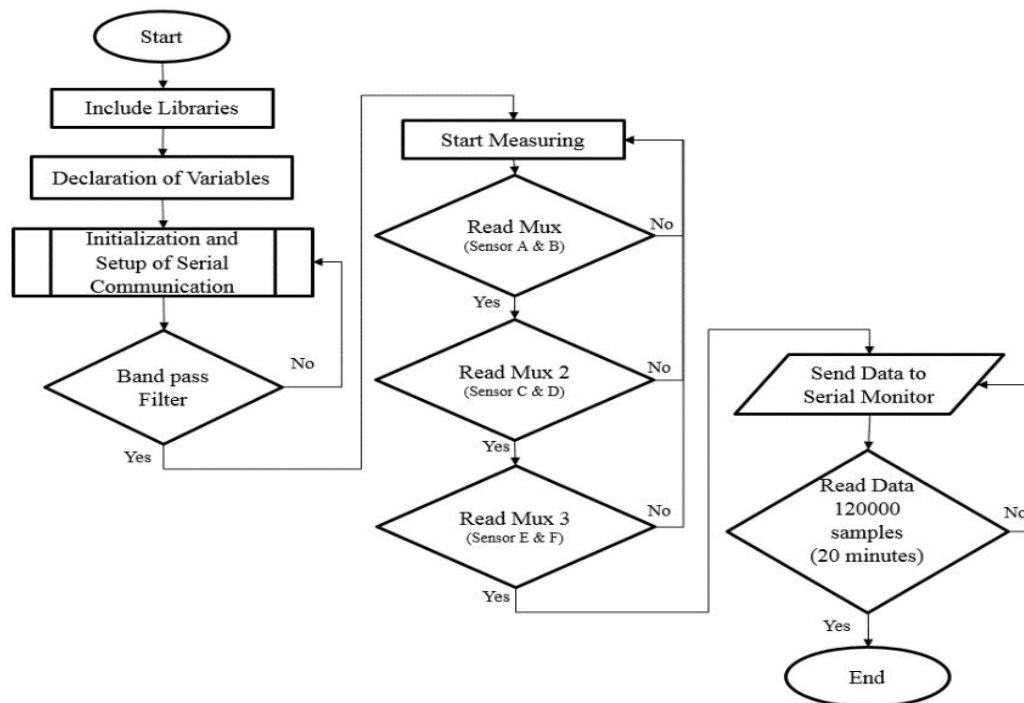

Figure-7. Flowchart of ARDUINO.

B-3. Output: MATLAB Interface

MATLAB interface was employed as the output unit for this work. MATLAB is a high-performance language with an interactive environment for technical computing. It integrates the computation, visualization, and programming in an easy-to-use environment where problems and solutions are expressed in familiar mathematical notation. In this work, the six sensors used were labeled so that each label can be easily recognized

and to enable MATLAB to differentiate each sensor and their axis. The next stage is to interface ARDUINO with MATLAB. The data received in ARDUINO can be seen in MATLAB interface. This was done because the data received from the FMs have to be transformed to numeric form so that MATLAB can further process it easily. MATLAB also has a serial monitor (Debugger) specifically designed for ARDUINO - MATLAB interface. The data was continuously updated on the



MATLAB window and when the serial monitor feature is closed in MATLAB, the application will automatically save all the displayed readings in the form of text file. This text file contains all the information received from the accelerometer sensor. This could be used in MATLAB for further signal processing or imported into Microsoft Excel for signal plotting and analysis in the form of a wave. For MATLAB command to differentiate each sensor and their axis, each label has to be easily recognized. The six sensors used were labeled with A to F with each sensor contains three axis and named as 1,2 and 3 for sensor A, followed by number 3,4 and 5 for sensor B. All six sensors and their labels are listed in Table-2

Table-2. Sensor labeling in MATLAB command.

Sensor	Axis	Coding label
A	X _{out}	1
	Y _{out}	2
	Z _{out}	3
B	X _{out}	4
	Y _{out}	5
	Z _{out}	6
C	X _{out}	7
	Y _{out}	8
	Z _{out}	9
D	X _{out}	10
	Y _{out}	11
	Z _{out}	12
E	X _{out}	13
	Y _{out}	14
	Z _{out}	15
F	X _{out}	16
	Y _{out}	17
	Z _{out}	18

Figure-8 illustrates the flowchart developed for MATLAB displaying is shown in. The coding began with

the start button followed by initialization before the communication. The new recording started by pressing the start button. The system was interfaced with ARDUINO. The set of data read by accelerometer was sent to the processor and read by MATLAB. The data were received by the system until it reaches the maximum data samples as stated in the coding. Then, the command for ARDUINO to stop transmitting the data was sent by the system, which further saved the date.

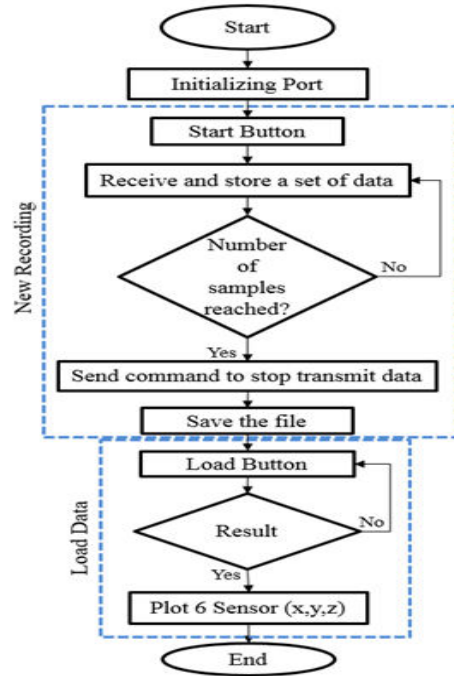

Figure-8. Flowchart of MATLAB for displaying.

The data recorded were saved and displayed in a graph as shown in Figure-9. The figure shows six windows consisting of the data of each sensor after recording. The colors are represented by axes; blue: X Axis, red: Y Axis, and green: Z Axis. Each window is also labeled with sensor A till sensor F for easy reference (refer Table-1). Each window represents every single sensor. For example, there are clearly shown two movements (spike) from sensor A. The data is easier to be recognized and analyzed.

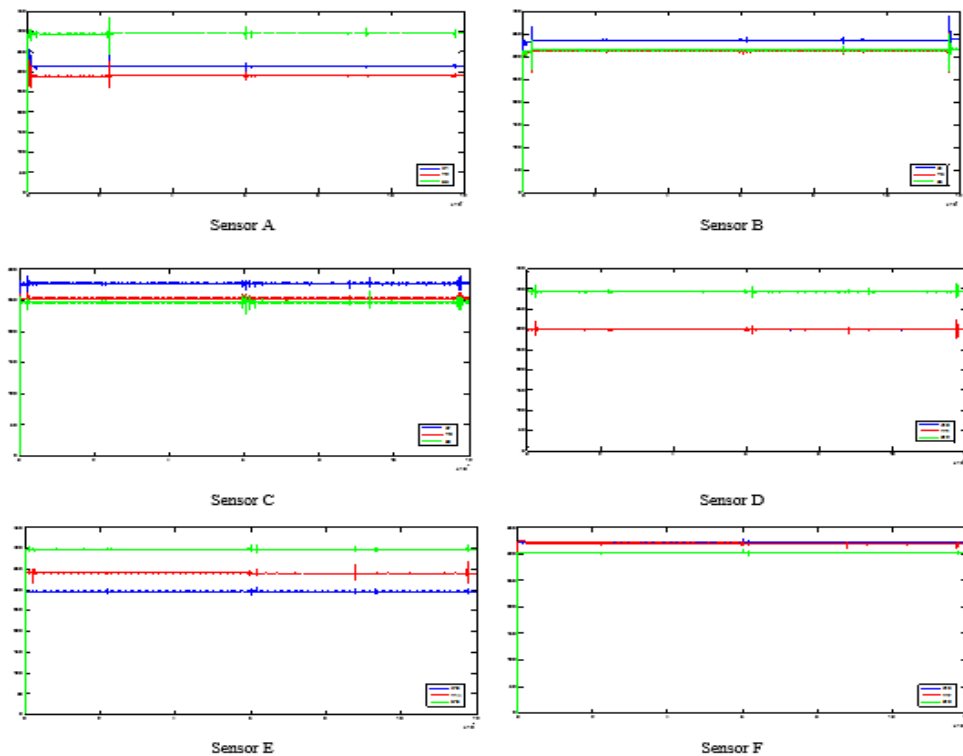

Figure-9. The result of six sensors data in each window.

4. PERFORMANCE EVALUATION

A. Experimental procedure

The proposed device was tested in the ultrasound room collaborated with a medical doctor. A group of 23 maternal were chosen by the medical doctor. The maternal were informed on the experiment and procedure, which were clearly explained to them. The maternal also given Patient Information Sheet & Consent Form that stated and explained about the experiment. As shown in Figure-10, the study began after the maternal agree and willing to go through the experiment. The experiment was conducted synchronously using the FMs recording system,

Ultrasound, and Maternal perception. According to [23], based on the study using six participants, the mean time for recording was 23.5 minutes. Hence for this study, 20 minutes was used for the data recording, considering the fact that the subjects might feel some discomfort if too much time is used. Data from ultrasound image was also recorded by a camera and later transferred into a graph by consultation with a medical doctor. Good cooperation from maternal ensured we got the best outcome from this experiment. Maternal ensured less noise reduced maternal movement, coughing and talking. A flow chart of the experimental procedure has been illustrated in Figure-10.

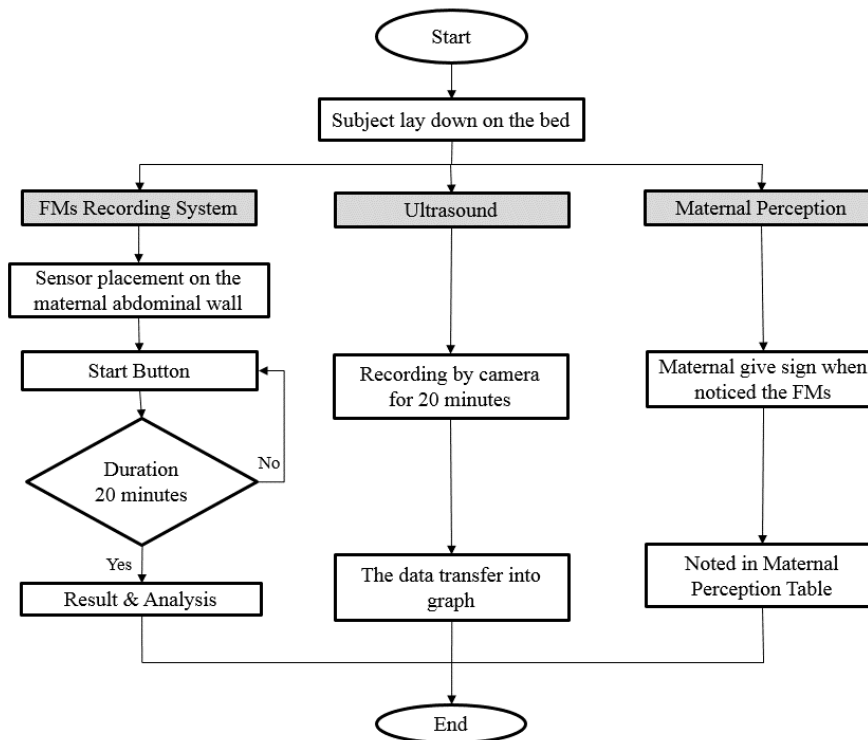

Figure-10. Flowchart of the experimental procedure.

5. RESULTS AND DISCUSSIONS

A comparison of three different methods namely; maternal perception technique, ultrasound, and FMs recording system were carried out to identify the best method to be used for monitoring fetal. This study has shown that the FM recording system can achieve better results and fulfill objective of the study which to help

maternal by monitoring the FMs. A systemic view of the internal circuit diagram of the complete system used to obtain the results is shown in Figure-11. The results displayed in Figure-9 and Figure-10 were obtained from an experiment conducted in two sessions (Morning and afternoon).

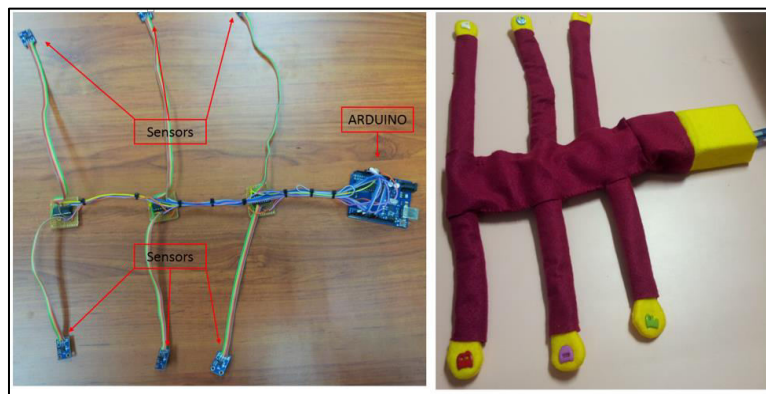

Figure-11. FMs Recording system device.

A. Morning session

Data was recorded for 20 minutes for each subject used. The session began at 8.30am through 10.00am. Maternal are quite active during this period. A Maternal start working and doing a lot of movements during this period, the fetal are normally active (rolling, kicking). Thirteen (13) different maternal subjects were tested for this session. The graph for this session majority showed three to five movements. The results Figure-12 is

for one of the maternal taken from this session. The graphs consist of an experiment carried out using three different methods; maternal perception technique (Green), ultrasound (Yellow) and FMs recording system (Blue). From the results displayed in Figure-12, maternal perception technique shows four (4) movements in this session. Ultrasound technique recorded three (3) small movements with one of them having different kinds of movement and three hard kicking from the legs. The FMs



recording system successfully recorded five (5) movements. The result also displays a movement percept by the maternal with no movement showed from

ultrasound and FM's recording system. This kind of movement scenario is known as a false active movement.

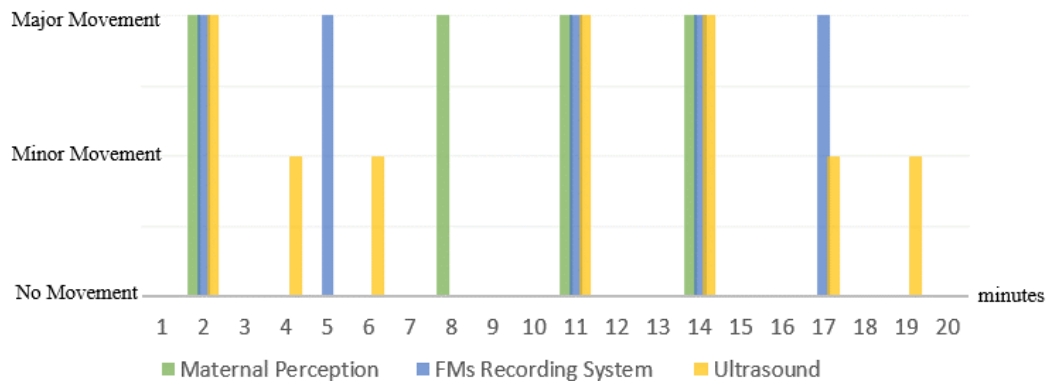

Figure-12. Maternal graph result (Morning session).

B. Afternoon session

During this session, the duration for data collection remained the same as the earlier session. The session began at 2.30pm and stopped 4.00pm. Maternal already had their lunch two hours before the test. During this period, fetal are normally asleep or resting (inactive). Ten (10) maternal were involved for this session. The graph from this session shows that majority of the maternal; has two to four movements during this period. A maternal result taken from this session has been displayed Figure-13. From the Figure shown, the graph consists of an experiment carried out using three different methods; maternal perception technique (Green), ultrasound (Yellow) and FM's recording system (Blue). Maternal perception technique showed only two movements. On the other hand, the ultrasound recorded three major movements and three slow movements with two of them in between only a few seconds. The FM's recording system has recorded four movements with the maternal unable to

percept the slow or slight movements although using full concentration. The maternal perception technique possessed the poorest result among all parameters. Ultrasound machine showed the real-time movements of the fetal even a slight and slow movement that cannot be felt by the maternal. This precise result made the ultrasound machine as the best technology to be used as fetal monitoring method during this period. Using the FM recording method, the graph showed no difference in whether it is slow movement or hard movement. It only displayed movements from the fetal. From this result, the recording data using FM's recording system are close to the number count from the ultrasound than maternal perception. Thus FM recording system gave a result close to the Ultrasound except inaccuracy during this period. The experimental result indicates that FM's recording system is as precise as ultrasound result and better than maternal perception technique.

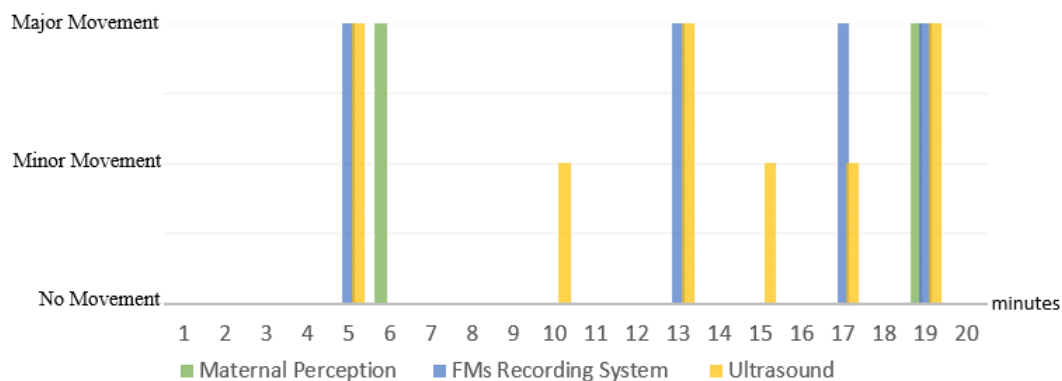

Figure-13. Maternal graph result (Afternoon session).

6. CONCLUSIONS

It has been standardized that FM's is measured by maternal perception technique. Today, most mothers have quite a busy carrier. They are occupied during the day and don't often pay attention to their fetal. When they return

from work, they are too tired at night. Thus the need to develop an accurate system for the monitoring of the FM over a long period of time. Monitoring FM's allows the mothers and clinicians to predict the condition and development of fetal. This study helps in developing tools



to make their life easy by monitoring their fetal. In this paper, we presented first results of an accelerometer-based FM recorder. The proposed system (accelerometer-based FM recorder) has six accelerometer sensors and ARDUINO microcontroller. The device which is interfaced with MATLAB signal process tool has been designed to record, display and store relevant sets of fetal movements. Initial results show the technique to be more effective in detecting FM than maternal perception. We have shown that the proposed detector performs better in identifying episodes of fetal activity and episodes of inactivity. Specifically, the system showed a good level of detection performance against the traditional techniques. Comparison of data recorded from FM with ultrasound and maternal perception technique gave an accuracy of 59.78%, 85.87% and 97.83% using the maternal perception technique, fetal movements recording system, and ultrasound respectively. However, still, it has some potential future works along the study, which could enhance the performance of the assessment tool. This work can be further extended by the addition of new features to upgrade the application such mothers can monitor their respective FMs at home.

ACKNOWLEDGEMENT

The authors gratefully acknowledge Universiti Teknologi Malaysia (UTM) for supporting and offering the required facilities and laboratory equipment. This study was conducted as a part of the Research University Grant Scheme, supported by Universiti Teknologi Malaysia, Government of Malaysia, under Grant number.Q.J130000.2545.14H66.

REFERENCES

- [1] Sadovsky E. and H. Yaffe. 1973. Daily fetal movement recording and fetal prognosis. *Obstetrics & Gynecology*. 41(6): 845-850.
- [2] Maeda K. 2014. Fetal movements. *J Health Med Informat*. 5: e115.
- [3] Nijhuis J.G. 2003. Fetal behavior. *Neurobiology of aging*. 24: S41-S46.
- [4] Al-Ashwal R.H., *et al.* 2016. Fetal Kicking Monitoring Device for Intrauterine Death Prevention. *Indian Journal of Science and Technology*. 9(13).
- [5] Saastad, E., *et al.* 2011. Fetal movement counting improved identification of fetal growth restriction and perinatal outcomes—a multi-centre, randomized, controlled trial. *PLoS One*. 6(12): e28482.
- [6] Winje B.A., *et al.* 2013. Wavelet principal component analysis of fetal movement counting data preceding hospital examinations due to decreased fetal movement: a prospective cohort study. *BMC pregnancy and childbirth*. 13(1): 172.
- [7] De Vries J.I., G.H. Visser and H.F. Prechtl. 1982. The emergence of fetal behaviour. I. Qualitative aspects. *Early human development*. 7(4): 301-322.
- [8] Winje B., *et al.* 2011. Analysis of ‘count-to-ten’ fetal movement charts: a prospective cohort study. *BJOG: an International Journal of Obstetrics & Gynaecology*. 118(10): 1229-1238.
- [9] Frøen J.F., *et al.* 2008. Fetal movement assessment. in *Seminars in perinatology*. Elsevier.
- [10] Khlif M.S.H., *et al.* 2012. A passive DSP approach to fetal movement detection for monitoring fetal health. in *Information Science, Signal Processing and their Applications (ISSPA), 2012 11th International Conference on*. IEEE.
- [11] Ungureanu G.M., *et al.* 2011. Prenatal telemedicine—advances in fetal monitoring, in *Advances in Telemedicine: Applications in Various Medical Disciplines and Geographical Regions*. InTech.
- [12] DiPietro J.A., *et al.* 1996. Development of fetal movement-fetal heart rate coupling from 20 weeks through term. *Early Human Development*. 44(2): 139-151.
- [13] Vullings R., *et al.* 2008. Fetal movement quantification by fetal vectorcardiography: a preliminary study. in *Engineering in Medicine and Biology Society, 2008. EMBS 2008. 30th Annual International Conference of the IEEE*. IEEE.
- [14] Wheeler T., *et al.* 1980. Changes in the fetal heart rate associated with fetal breathing and fetal movement. *BJOG: An International Journal of Obstetrics & Gynaecology*. 87(12): 1068-1079.
- [15] Baser I., T.R. Johnson and L.L. Paine. 1992. Coupling of fetal movement and fetal heart rate accelerations as an indicator of fetal health. *Obstetrics & gynecology*. 80(1): 62-66.
- [16] Ryo E., *et al.* 2012. A new method for long-term home monitoring of fetal movement by pregnant women themselves. *Medical engineering & physics*. 34(5): 566-572.
- [17] Nishihara, K., *et al.* 2008. A long-term monitoring of fetal movement at home using a newly developed



sensor: An introduction of maternal micro-arousals evoked by fetal movement during maternal sleep. Early human development. 84(9): 595-603.

- [18] Thomas G., *et al.* 2010. Detecting fetal movements using non-invasive accelerometers: A preliminary analysis. in Information Sciences Signal Processing and their Applications (ISSPA), 2010 10th International Conference on. IEEE.
- [19] Adithya P.C., *et al.* 2017. Trends in fetal monitoring through phonocardiography: Challenges and future directions. Biomedical Signal Processing and Control. 33: 289-305.
- [20] Kshetri N. 2016. Big data's role in expanding access to financial services in China. International Journal of Information Management. 36(3): 297-308.
- [21] Puers R. 1993. Capacitive sensors: when and how to use them. Sensors and Actuators A: Physical. 37: 93-105.
- [22] Altini M., *et al.* 2016. Detection of fetal kicks using body-worn accelerometers during pregnancy: Trade-offs between sensors number and positioning. in Engineering in Medicine and Biology Society (EMBC), 2016 IEEE 38th Annual International Conference of the. IEEE.
- [23] Boashash B., *et al.* 2014. Passive detection of accelerometer-recorded fetal movements using a time-frequency signal processing approach. Digital Signal Processing. 25: 134-155.