

R/2004/S3

AFI 1-05

---

# RABID

**Basal conditions on Rutford Ice Stream, West Antarctica:  
– Hot-water drilling and down-hole instrumentation**

**FIELD REPORT 2004/05 SEASON**

*A M Smith*

*Physical Sciences Division, British Antarctic Survey*

**Distribution:**

1. AFI Office
2. BAS Archives
3. BAS Rothera
4. Author
5. K. W. Nicholls, BAS
6. T. Murray, University of Swansea
7. K. Makinson, BAS
8. G. Aðalgeirsdóttir, University of Swansea
9. A. Behar, NASA-JPL

## Contents

Summary	1
1. Introduction	
1.1. The West Antarctic Ice Sheet	1
1.2. The RABID Project	2
1.3. Personnel	2
1.4. Rutford Ice Stream	2
1.5. Logistics	2
1.6. Additional BAS & NASA-JPL Project	3
2. The RABID Project 2004/05	
2.1. Diary	4
2.2. Narrative	
2.2.1. Input, getting established and preparation for drilling	4
2.2.2. Drilling	9
2.2.3. The final few weeks	13
2.2.4. Final uplift	16
3. Equipment	
3.1. Hot-water drill	16
3.2. Seismic reflection equipment	17
3.3. GPS	17
3.4. Passive seismic equipment	19
3.5. Ground-penetrating radar (GPR)	19
3.6. Power	19
3.7. Weather station	20
3.8. Thermistor string	20
3.9. Instrument strings	20
3.10. Sediment coring	20
3.11. Tethered stake	20
4. Preliminary results	
4.1. Seismic reflection	21
4.2. GPS	21
4.3. Passive seismics	21
4.4. GPR	23
4.5. Weather	23
4.6. Preliminary scientific conclusions	24
4.7. Data management	24
5. Recommendations	25
Appendices	
RABID APPENDIX A: FGA Report (includes site positions)	26
RABID APPENDIX B: Hose loss reports and investigations	60
RABID APPENDIX C: Related links	73

# RABID

## Summary

The main fieldwork for project AFI 1-05 (the RABID project) was carried out on Rutford Ice Stream in the 2004/05 field season. The biggest scientific task was to access the ice stream bed using a hot-water drill. This would enable a number of investigations within the bed and the ice. The project also involved a substantial suite of surface geophysical measurements. Together, these formed an integrated programme studying ice dynamics, basal conditions and climate and glacial history. Although the drilling reached within ~100 m of the bottom of the ice (ice thickness ~2200 m), irretrievable equipment failure meant that we did not reach the ice stream bed. The surface work was much more successful and is giving significant and in some cases, unexpected, results.

## 1. INTRODUCTION

### 1.1 The West Antarctic Ice Sheet

Collapse of the West Antarctic Ice Sheet would lead to a rise in global sea level of over 5 metres. Complete collapse is thought unlikely within the next few hundred years, but less extreme changes are certainly possible and could still significantly affect sea level and the Earth's low-lying coastal regions. Ice from the interior of Antarctica is delivered to the ice shelves, and hence the oceans, through fast flowing glaciers and ice streams. These ice streams are the most dynamic components of the ice sheet system. They flow up to two orders of magnitude faster than the rest of the ice sheet and thus act as the

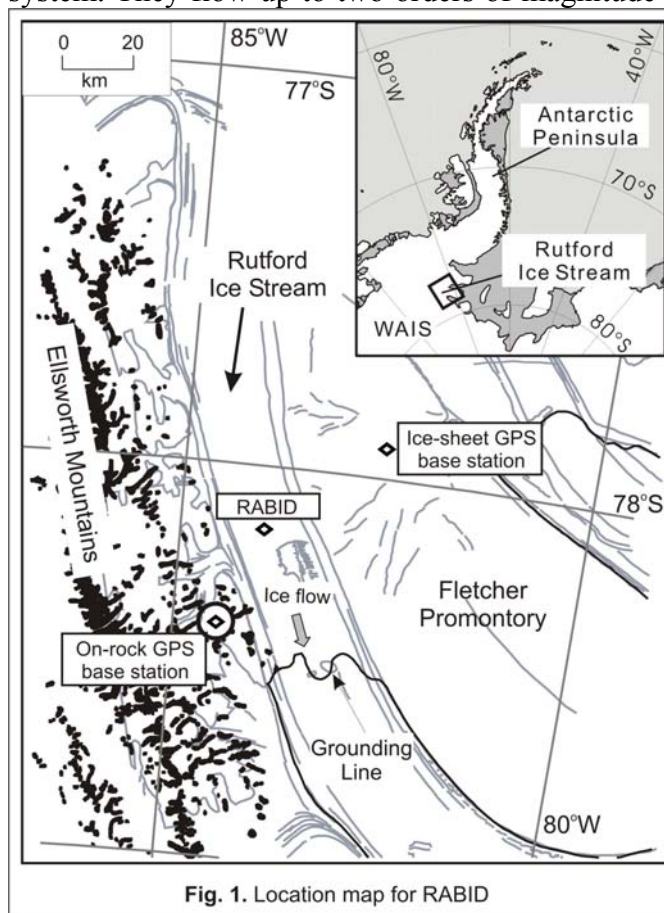

Fig. 1. Location map for RABID

principle volume regulators controlling the continent's ice cover. An understanding of the dynamics of these fast-flowing ice masses and their drainage basins is fundamental to our assessment of ice sheet stability. During the 2004/05 austral summer, a major multi-component experiment was conducted on Rutford Ice Stream, West Antarctica (Fig. 1). The overall aims of the project were to determine:

- the relative importance of ice creep, basal sliding and sediment deformation on the ice flow regime,
- the nature of the basal hydrological system and its influence on the different flow mechanisms,
- the effects of tidal forcing on ice stream flow and whether transmission is via the bed or the ice,
- the age of any subglacial marine sediments and the Cenozoic glacial stability of the region,
- the recent temperature history of the region,
- the degree of ice-bed interaction and origin of any basal-ice sediment.

## 1.2 The RABID project

To achieve the aims outlined above we planned to:

- ▶ Use seismic reflection surveys to determine the experiment locations.
- ▶ Drill access holes to the ice stream bed using a hot-water drill.
- ▶ Retrieve sediment samples from the bed.
- ▶ Detect any differential motion between the ice and the bed using tethered stake instruments.
- ▶ Measure temperature, tilt and water pressure using strings of sensors emplaced in the ice.
- ▶ Retrieve sections of ice core from critical depths within the ice column.
- ▶ Deploy a network of GPS receivers and seismic recording stations around the drill sites.
- ▶ Map the local spatial accumulation distribution with ground-penetrating radar (GPR).

Two holes were proposed at each of two locations, where different conditions had previously been identified beneath the ice. At each location, the first hole would be relatively narrow and drilled quickly. An instrument string would be deployed in this hole. The first hole would also indicate the exact ice thickness, which would be particularly useful when drilling the second hole. The second hole would be wider and would be used to retrieve basal sediment, followed by deployment of a tethered stake.

## 1.3 Personnel

The full list of people involved in the RABID fieldwork was:

Andy Smith	BAS
Keith Nicholls	BAS
Keith Makinson	BAS
Tavi Murray	University of Leeds (now Swansea)
Guðfinna Aðalgeirsdóttir	University of Leeds (now Swansea)
Alberto Behar	NASA-JPL
Alex Taylor	BAS FGA
Alex Cottle	BAS Project Assistant
John Withers	BAS

Numbers actually at RABID fluctuated throughout the season. After the initial input of two people, numbers increased steadily. The maximum number at any one time (not including transient visitors) was seven. Six people took part in the first drilling period, seven in the second.

## 1.4 Rutford Ice Stream

Rutford Ice Stream is a fast-flowing glacier that drains part of the West Antarctic Ice Sheet into Ronne Ice Shelf. It is roughly 200 km long, 20-25 km wide, 2-3 km thick and flows at around 300-400 m a<sup>-1</sup>. Field parties have worked there many times since 1978 resulting in a good, broad understanding of its geometry, dynamics and glaciological regime. In particular, seismic surveys had shown that the bed comprises wet sediments, which in some places are very soft and actively deforming, whereas elsewhere they are harder and the ice is sliding over them.

## 1.5 Logistics

The RABID project was funded in the first round of AFI in early 1999. The long period between approval and fieldwork was scheduled to allow BAS Operations sufficient time to establish a large depot of fuel and equipment, in preparation for the field season. By the end of the 2003/04 season (the one prior to the fieldwork) the RABID Depot contained approximately 13 tonnes of field and drilling equipment, and ~200 drums of fuel. During the field season itself (2004/05) an additional 16 tonnes was input, including all personnel plus scientific, drilling and field equipment.

### 1.6 Additional BAS & NASA-JPL Project

Development of a down-hole video camera was not included in the original RABID proposal. However, in the time between proposal and fieldwork, researchers at NASA-JPL had developed such an instrument and deployed it successfully with the US Antarctic Program on Ice Stream C. Recognising the significant benefits this could add to RABID, a collaborative agreement between BAS and JPL enabled a separate BAS project to be added to RABID, involving an equipment upgrade to ~2.5 km capability (Ice Stream C is only around 1 km thick) and providing the extra resources to add the equipment and one JPL person to the RABID field party.

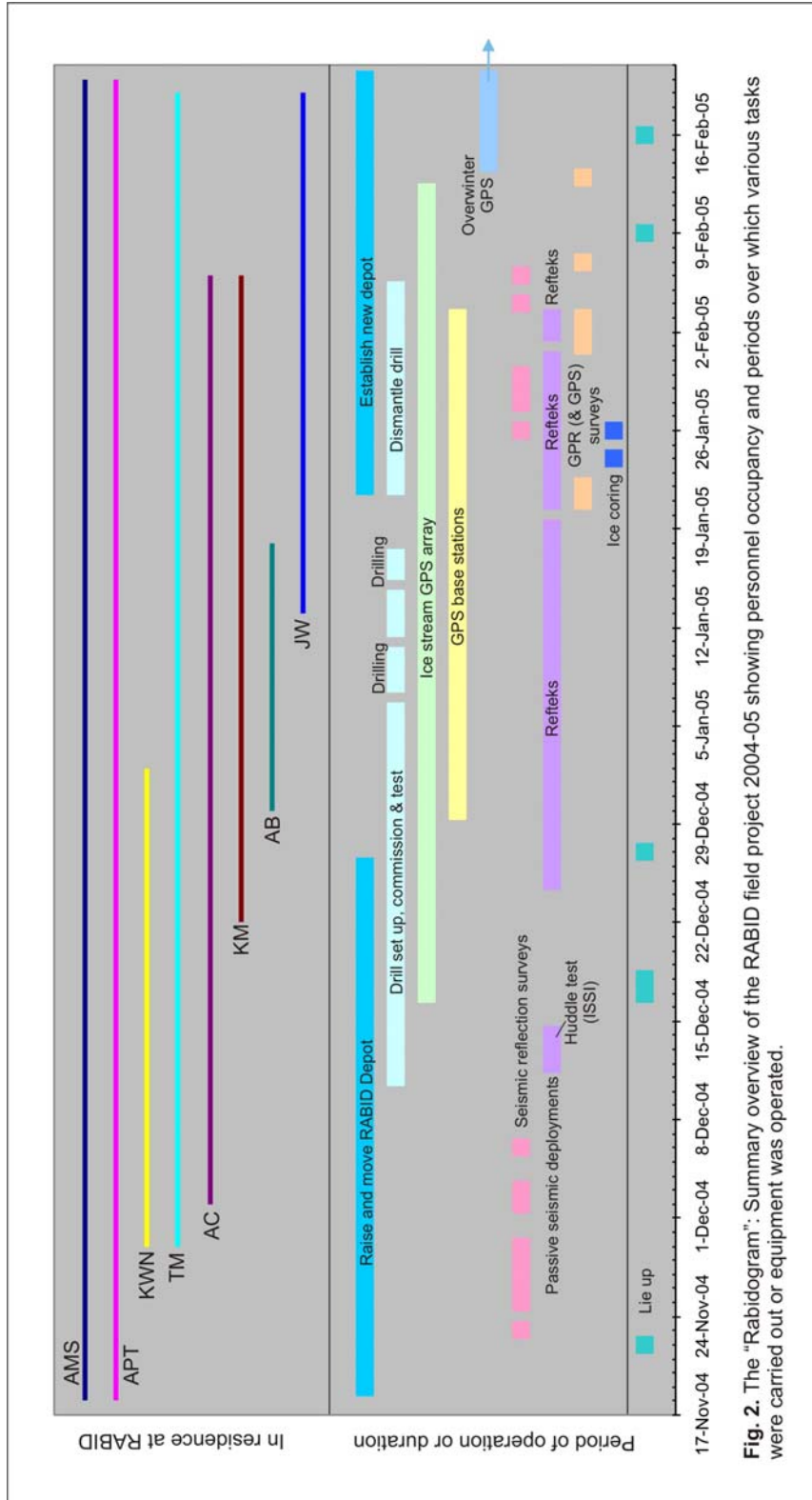

Fig. 2. The "Rabidogram": Summary overview of the RABID field project 2004-05 showing personnel occupancy and periods over which various tasks were carried out or equipment was operated.

## **2. THE RABID PROJECT 2004/05**

### **2.1 Diary**

See FGA report in Appendix A for a full diary (page 52) for the field season. Fig. 2 gives a schematic overview of the complete field programme.

### **2.2 Narrative**

#### **2.2.1 Input, getting established and preparation for drilling**

##### *Input*

The first project members arrived in the Falklands on 23 October. The others followed at various stages after that. Initial delays in the Falklands waiting for the Dash-7 flight to Rothera were longer than usual (2-3 weeks). However these delays have to be accepted as part of working in Antarctica. Unfortunately, they did have knock-on effects for RABID which would not be the case in smaller, less complex projects and this did cause problems over the following weeks, particularly with personnel numbers. An additional loss at this stage was one team member who had to return to UK with a torn achilles tendon – the first casualty of RABID.

The first RABID personnel reached Rothera on 10 Nov. A quick passage through Rothera saw the first two people leave base and arrive on Rutford Ice Stream on 18 Nov. Input of cargo and personnel continued steadily from then onwards.

##### *First tasks*

The first tasks were:

1. Start digging out and raising the depot
2. Recce. the local area to determine the safe and the unsafe travel areas
3. Locate the starting point for the reconnaissance seismic reflection lines
4. Complete two seismic reflection lines to determine the drilling locations.

While these were going on, regular flights brought in more equipment and supplies.

The RABID depot, established over the previous four years, had been left on the surface at the end of the preceding season (Fig. 3). When we arrived in November 2004, the top of the depot was approximately 0.5 m below the surface. This is about the amount of accumulation we had expected from previous experience in the area. Digging out and raising the depot was made relatively easy by two things. Firstly the depot had been prepared extremely well by those who completed it. Secondly, the small Honda snow-blower was put to very good use. These should become standard equipment for raising any significant depot. The task of raising the complete depot was spread over many weeks. Once the two proposed drill sites had been located, the whole depot was moved to those locations, approximately 6 km further upstream from the original site.

The local area was explored in the normal BAS linked-travel system. Crevasses are known to exist to the east of the original depot location. There are no known crevasses in the area upstream of this, which is where we planned to work. At the start of the season, no evidence was found of any crevasses anywhere in the area and all remained very well bridged for the whole season. Those east of the depot could just be seen from a distance in certain lighting conditions later in the season, as the bridges slumped slightly. However, they still remained very difficult to identify at close quarters. Although it is possible there may have been undetected crevasses elsewhere in the area, this is most unlikely, for a number of reasons:

- Many BAS field parties have worked in this area over 2 decades. In the area we were working, there has never been any indication of crevasses.

- The ice dynamics, and the basal topography and conditions in the area are well-known. These suggest that crevasses are most unlikely to occur here.
- Seismic reflection and GPR surveys are extremely good at indicating crevasses. Many of these surveys have been carried out in this area, none of which have shown crevassing.

Once the safety reconnaissance had been completed, linked travel was not used in the regular work and travel areas. Main routes between camps, depots and equipment sites were well marked with flag lines and could be travelled safely in most weather conditions.



Fig. 3a. The RABID Depot, February 2004



Fig. 3b. Digging out the RABID Depot, November 2004.

#### Drill site location

The locations where we planned to drill were to be determined by the conditions at the ice stream bed, interpreted from seismic reflection profiles. Previous surveys had shown some areas of the bed in this area were composed of very soft, water-saturated sediments, which are deforming with the flow of the ice. Elsewhere, whilst the bed is still water-saturated sediments, they are not deforming and the ice is sliding over them. The first main target for RABID was to drill at a deforming bed location; the second was a basal sliding location.

#### Seismic reflection surveys

Seismic surveys carried out in 1991-92 had shown excellent candidates for drill hole locations and we expected there to be little change at the bed over the intervening years. However, we could not be absolutely certain that conditions had not changed in the meantime, so we repeated the relevant section of the original seismic survey, plus an orthogonal line for additional control, to determine the exact location of the first drill hole. The first seismic line (Tyree04 Line) was orientated across the ice stream, the second (Mogensen Line) was in line with the ice flow, crossing the first in the area where we expected to

drill. The seismic surveys were identical to those carried out previously and full details of the operations are given in relevant BAS field reports. The processed seismic sections are given in Fig. 4, locations are given in Fig. 5.

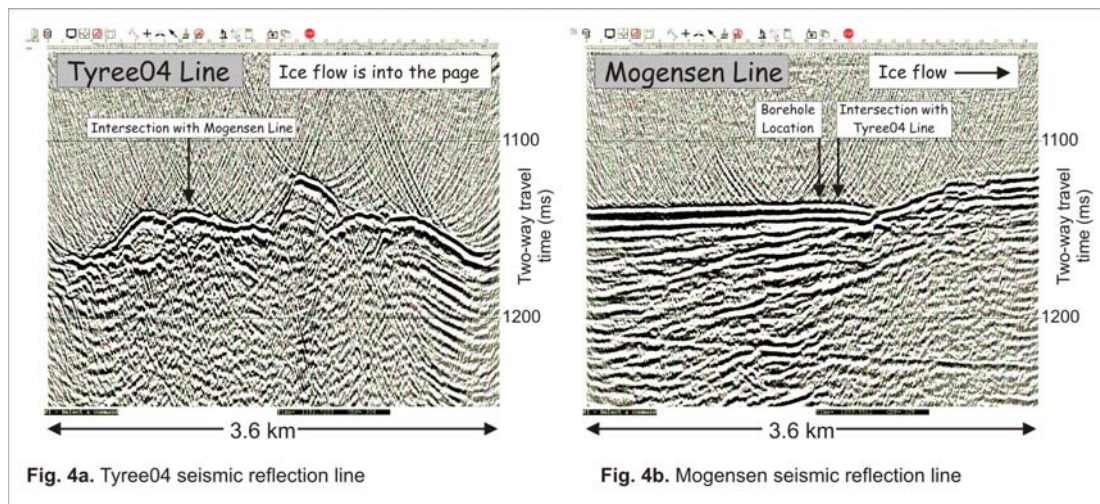
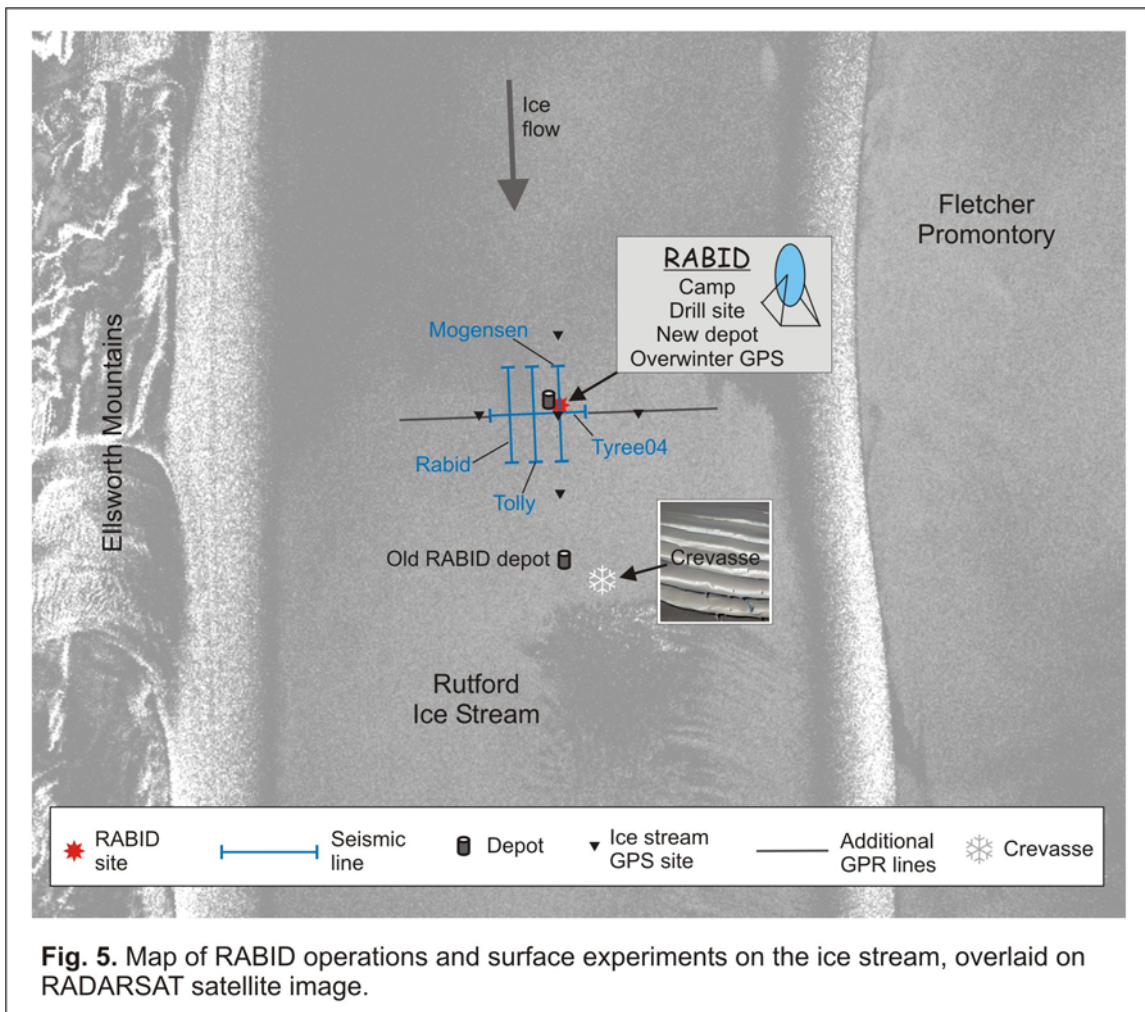

Fig. 4a. Tyree04 seismic reflection line

Fig. 4b. Mogensen seismic reflection line

### Camp and Drill setup

Once the location of the first drill hole had been determined, we set up the camp and the hot-water drill. The camp accommodation comprised two Weatherhavens and a varying number of pyramid tents. The larger Weatherhaven (20'x14') was used for communal living and cooking. Heating was provided by a simple drip-feed stove (Tharrington) burning avtur. Domestic water was provided by a large melt-tank with an identical burner to some of the hot-water drilling heaters. Radios, iridium phones and laptops for e-mail were set-up on a bench with aerials, solar panels and batteries nearby outside. This Weatherhaven has an insulating liner in the walls that reduces the amount of sunlight getting through so electric lights were also installed. Electrical power was usually from Honda 1kW or 2kW portable generators, which were adequate for powering most equipment in the communal tent (including a breadmaker). During drilling periods, when the large generators were running, we also had sufficient power for the water-urn. The second, smaller Weatherhaven was used as a work tent. Once the main camp had been established, the pyramid tents were normally used just for sleeping.



The lay-out of the camp (Fig. 6) was quite specific. The drill monitoring and logging equipment was run in the work tent, which had to be close enough for the signal cables to reach it. We wanted the communal tent to be further from the noise of the drill and domestic generators, yet still within reach of the power cables. Once drilling started, work would be round-the-clock, so the pyramid tents were pitched a few hundred metres away from the rest of the camp, so that anyone sleeping wasn't too disturbed. Depots of fuel and equipment were placed on the opposite side of the drill site to the camp, in appropriate locations for access when needed. Strong winds on Rutford Ice Stream come invariably from upstream or downstream so camp, drill site and depots could be aligned to minimise drift. Whilst camp set-up, seismic surveys and depot-raising were going on, the hot-water drill was steadily being built up, commissioned and tested. Fig. 7 shows the fully-operational RABID field camp.



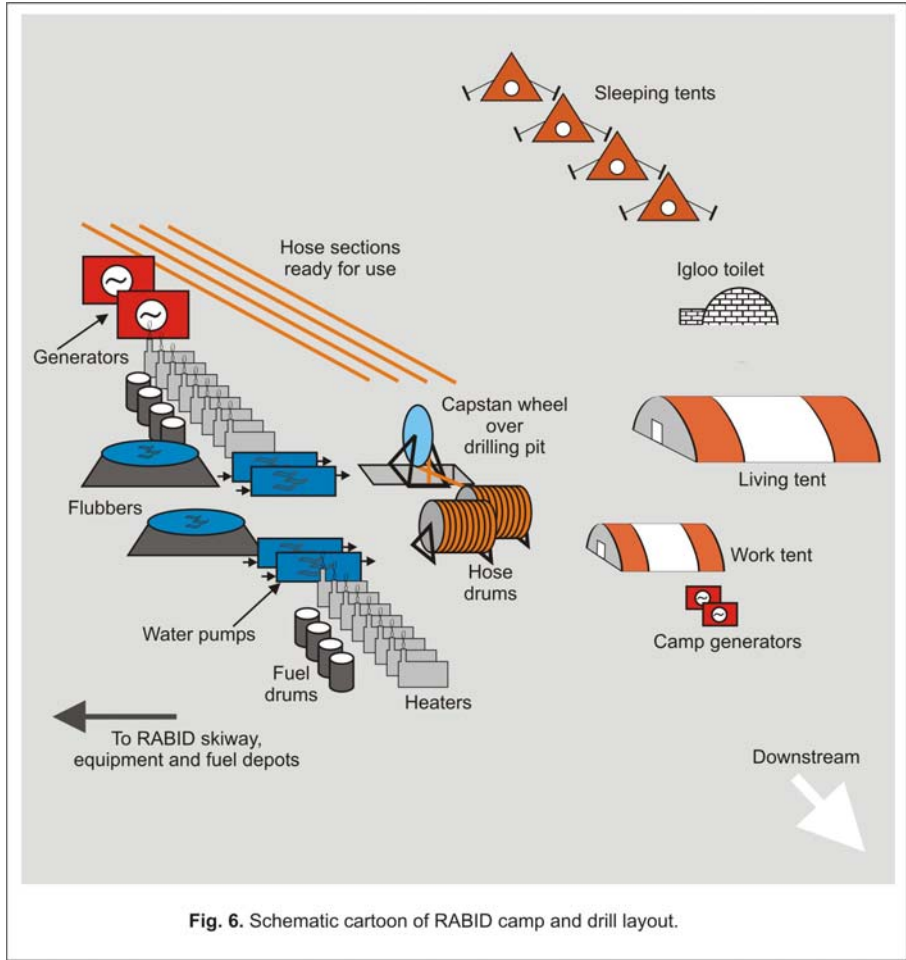

*Passive Seismic Network*

We had 14 new ISSI SAQS passive seismic stations plus peripheral equipment, provided by the NERC Geophysical Equipment Facility (GEF). This was the first time they had been used and were to give information on seismicity at the base of the ice. We intended to establish a network of stations around the drill site and the surrounding area as early as possible and to keep it running throughout the season.

First, we carried out a huddle test, with all the stations deployed at the same location. Sensors were buried in a trench ~1.5 m deep and data were recorded for one day. However, when we looked at the data from the huddle test we could see none of the expected events. The equipment appeared to be working correctly and

would detect larger events (eg people walking around, or skidoos) but appeared to be just not sensitive enough for the ice stream environment. Seismic events from the ice stream bed are quite weak but the background noise is also very low. The noise levels within the instrument were simply too high to see any events. Fortunately, we had two older Reftek stations with us – instruments which have been used successfully for this work before. By deploying Reftek and ISSI stations at the same locations we could show that the seismic events were occurring as expected, but that the ISSI was just too noisy for us to see them (see Fig 8). We got considerable help from the GEF and from ISSI in South Africa over many weeks to try and solve the problems. However, despite a considerable amount of time and effort, we were unsuccessful and acquired no useable data from the ISSI stations.

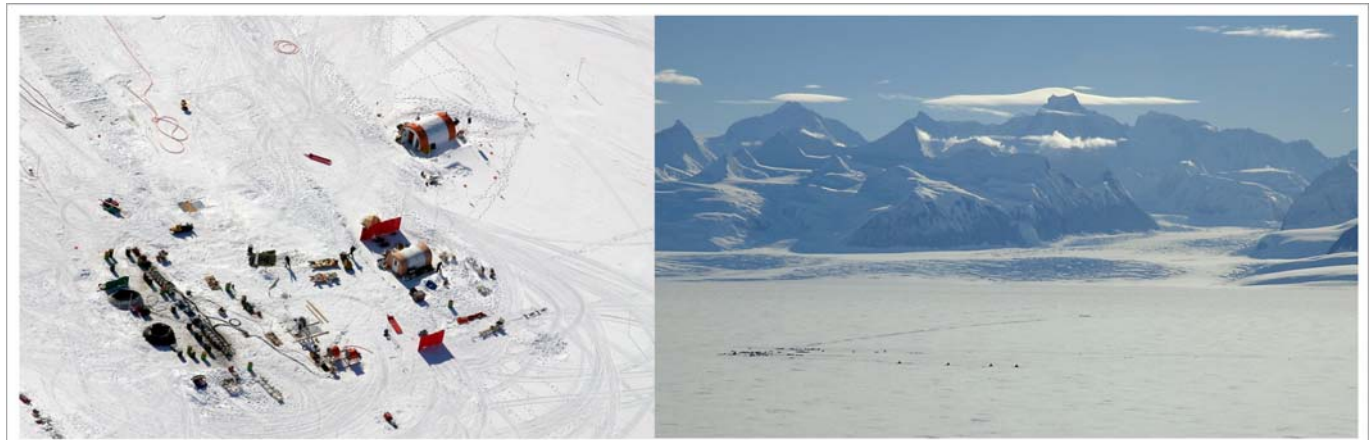

**Fig. 7.** Aerial views of the RABID camp

### GPS Network

A GPS network was established early in the season and kept running till the end of the project. The initial intention was to co-locate GPS receivers on the ice stream with some of the passive seismic stations, but in the end, that network was never deployed. Five GPS receivers were deployed in a diamond pattern around the first drill site (Fig. 5). The first station was approximately 200 m downstream from the drill site (i.e. far enough from any camp disturbances, had we been able to deploy the seismic stations) and this formed the centre of the ice stream array. Four other receivers were each 3 km from this central one – upstream, downstream and in the two cross-stream directions. All these stations were visited regularly throughout the season to collect data and check power supply.

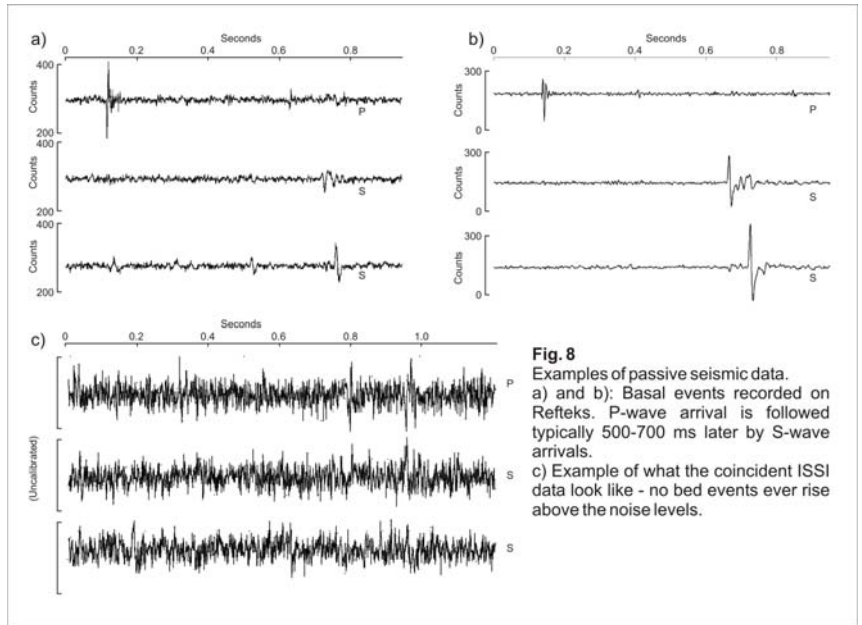
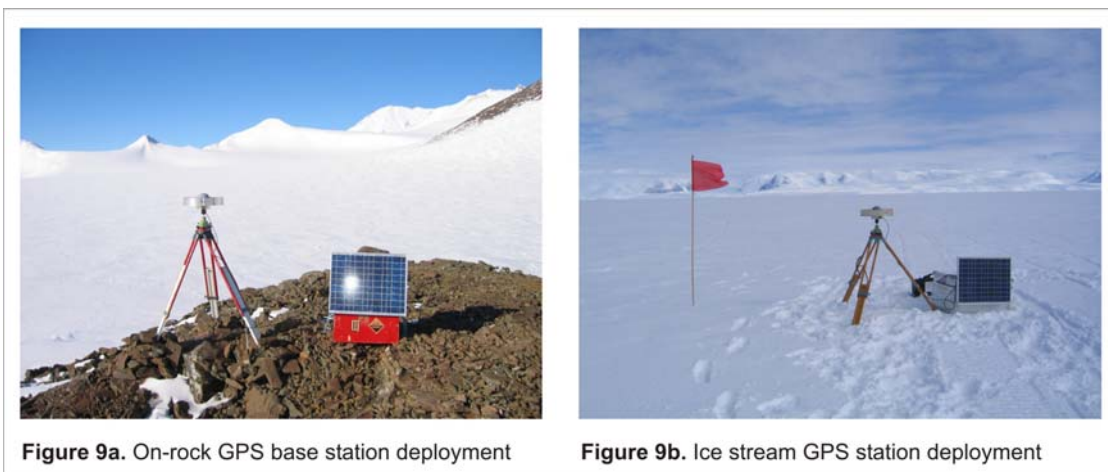

**Fig. 8**  
Examples of passive seismic data.  
a) and b): Basal events recorded on Refteks. P-wave arrival is followed typically 500-700 ms later by S-wave arrivals.  
c) Example of what the coincident ISSI data look like - no bed events ever rise above the noise levels.

To improve the accuracy of the data from the ice stream GPS network, two base stations were established adjacent to the ice stream. Both needed an aircraft to get to them and were set up to run unattended for the whole deployment. The first was on the crest of Fletcher Promontory (Fig. 1), which has been used before for the same purpose, as access by air is easy. However, it was not an ideal base station for RABID for two reasons.

- Fletcher Promontory is slow-moving ice - the fact that it is moving, albeit slowly, makes the resulting data less accurate.
- The closest position of a triple-junction on the crest, which is where we put the base station, is over 40 km from the RABID site. This is a long baseline, again resulting in less accurate control for the ice stream sites.

To improve the control on the ice stream GPS network, we were able to put another base station on a small outcrop of rock in the Flowers Hills (Fig. 1). These are a group of low hills at the edge of the Ellsworth Mountains, very close to the edge of Rutford Ice Stream. A good place to land the plane was found easily and we taxied to within ~200 m of the outcrop (unofficial name “Tolly’s Heel”). Access to the outcrop was straightforward, with no sign of a bergschrund or other crevassing, and only a small amount of height to climb. This base station was only ~25 km from RABID and has been left well-marked by a cairn, covering a notch cut in the rock, in case it is useful for other parties in the future. See FGA report (Appendix A) for further details of access to this base station. Examples of the GPS deployments are shown in Fig. 9.



**Figure 9a.** On-rock GPS base station deployment

**Figure 9b.** Ice stream GPS station deployment

### 2.2.2 Drilling

The capstan wheel was erected over a drilling pit ~2 m deep accessed by ladder. The first instrument string was assembled and draped out over the snow ready for deployment. A brake-bar system was prepared next to the drill pit to control the lowering of the string. Drums of fuel were placed close to the heaters and generators ready for re-fuelling.

#### *Drilling the first hole*

We began drilling on 8th Jan 2005. We were expecting a non-stop period of work lasting up to around 36-48 hours (though in the end it went on for longer). By this stage, the team was 6 people and we planned a quasi-shift system, which gave everyone periods when they could get sleep. First, a cavity was created at around 60 m depth and three submersible pumps lowered into it to recover and re-circulate the drilling water. We then started drilling the main hole. Fig. 10 shows a schematic of the drilling operation. This continued steadily, with few problems, through the following day. At a depth only a few hundred metres above the bed, we became concerned that the tension in the drill hose was no longer increasing as we expected and we decided to return the drill to the surface to see if this was due to sediment entrained within the ice. With the drill at the surface, there was no evidence of any sediment and we returned the drill to the bottom of the hole and started drilling again. By then it was late afternoon on 10th Jan and the weather suddenly deteriorated very rapidly. Over a period of ~30 minutes the wind picked up from calm to over 25 knots and snow began falling heavily (see weather data in Fig. 11). A recurrence of the unexpected behaviour of the hose tension finally led to the decision to abandon the hole. The final depth reached in this hole was ~1900 m. The drill was recovered, followed by the submersible pumps and everything was packed away by 22:00 on 10th Jan.

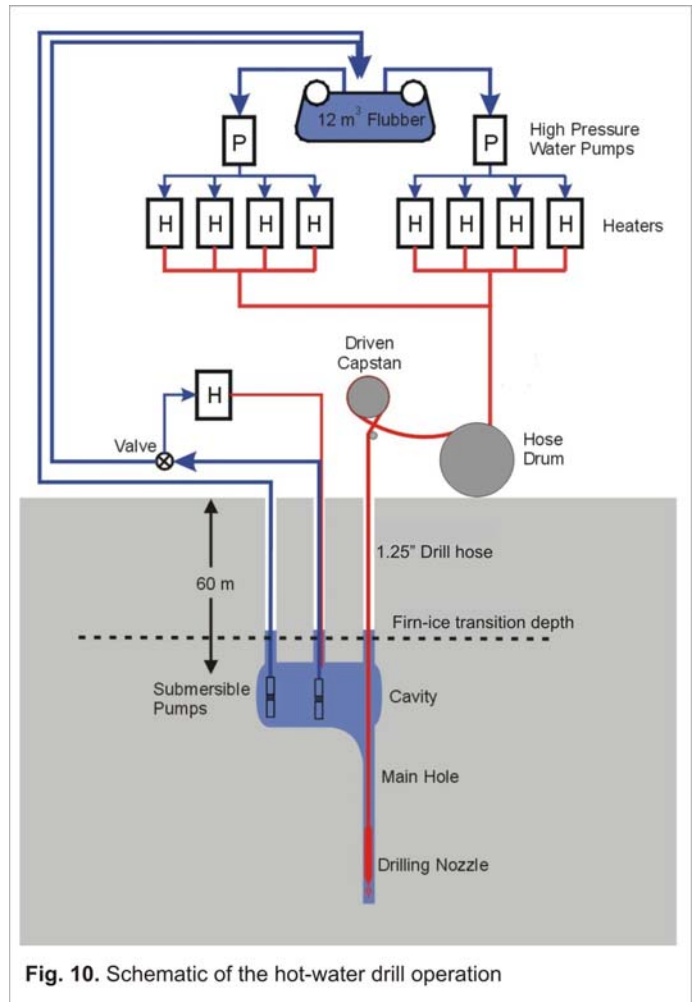

Fig. 10. Schematic of the hot-water drill operation

#### *Reflections on drilling the first hole*

Although it was disappointing not to have reached the bed there were many positive results to take from the first drilling period. Up until the hose tension issues at around 1900 m depth, the drilling had gone extremely well. Problems along the way had been relatively minor and all were resolvable with little or no impact on the drilling operation. Just drilling to this depth so quickly and efficiently was a considerable achievement. Despite being in a storm and after more than 60 hours non-stop operation, the recovery of the drill from 1900 m and the decommissioning and packing away was controlled and efficient. The performance of the drill itself had been good. Fuel consumption was slightly less than expected. The monitoring system and the reamer to adjust drilling rates and produce a constant hole diameter, all seemed to be operating well. Although we had used up a certain amount of time and fuel, these were only a small proportion of what we had available.

One of the biggest questions to address was the issue of hose tension at depth. We believed there were two possible likely explanations for the reduction in tension:

- Increased friction with depth from the prussik loops at each hose coupling (every 200 m), dragging on the side of the hole
- Operation of the reamer

Both these possibilities could be addressed relatively easily:

- Although we considered hose failure unlikely, if it were to occur it would be in the upper part of the hose. Hence by removing the prussiks which would reach the deeper part of the hole, we could reduce any possible friction problems. Keeping the prussiks in the upper part would still protect against any coupling failure, without causing significant drag.
- Operation of the reamer could have been the cause of the lower tension values, than expected. The reamer is located 50 m above the drill nozzle. Its purpose is to ensure the hole drilled in the ice is

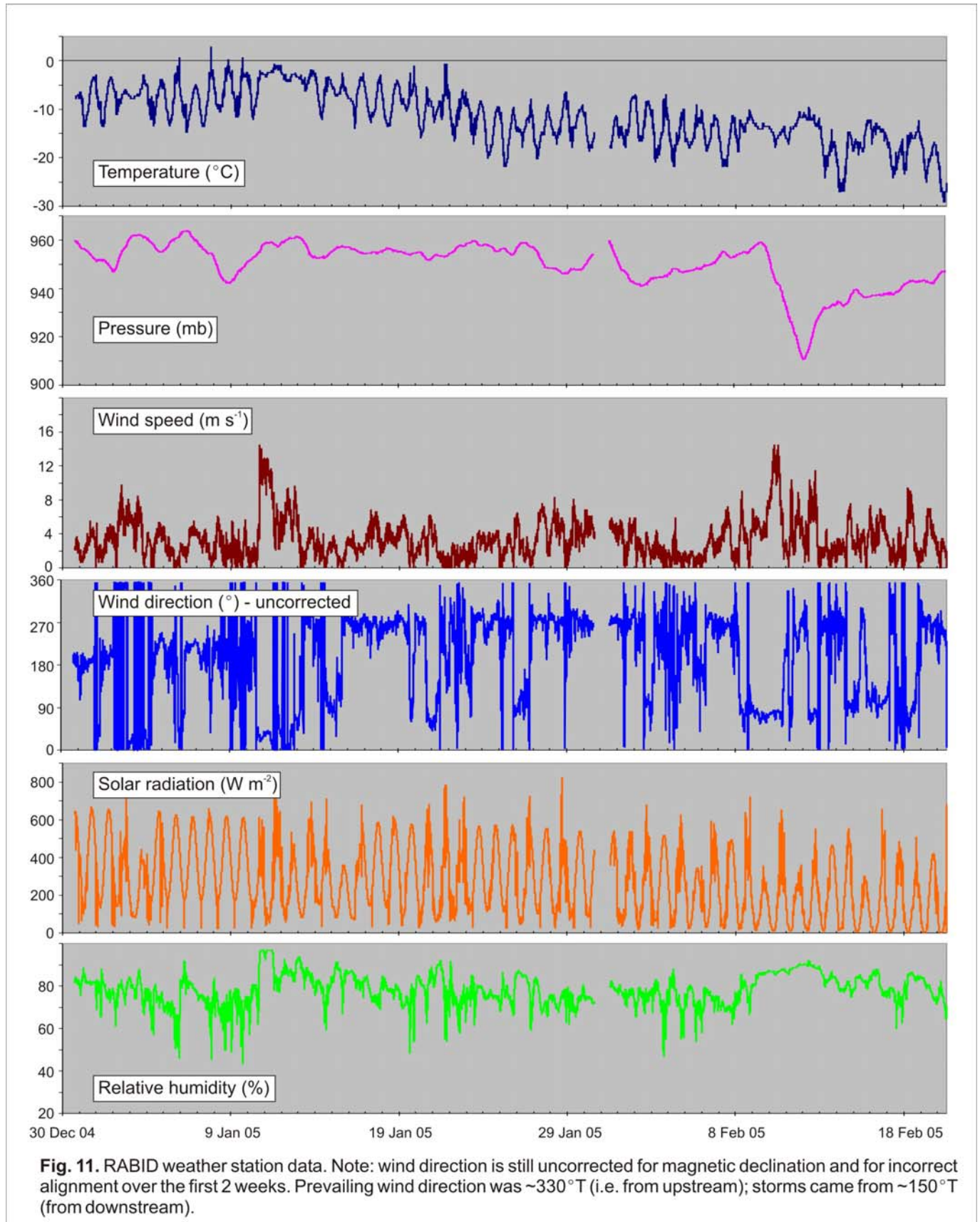

at least a certain minimum diameter. Any constriction in the hole, less than this minimum will cause the reamer to operate – some hot water will be diverted to the restriction, widening it to the correct value. While this is happening, there are likely to be reductions in both the drilling rate and the hose tension. When the restriction has been removed, the reamer disengages and drilling returns to normal. Automatic operation of the reamer is probably an indication that the properties of the ice at that depth (in particular its temperature) are not quite what was expected. To allow for this possibility, whenever low hose tension occurred, we would stop drilling and raise the drill back up the hole ~100m, keeping hot water flowing. We would then reduce the water temperature and the flow rate while the drill was returned to the bottom of the hole, where normal temperature, flow and drilling would be resumed. This sequence would eliminate the risk of the drill deviating from the hole as it was lowered back down to the bottom.

#### *Preparations for hole two*

After sufficient recovery time for personnel, we prepared to drill again. The layout of the whole site had been designed to allow more than one hole to be drilled by moving as little heavy equipment as possible. Fuel depots, flubbers, heaters, generators, hoses and the work tent stayed where they were. A new pit was made, ~10 m away from the first one. All that had to be moved were the capstan, the hose drums and the controls. Preparations for drilling again also involved the arrival of John Withers. We had been short of people (by one and sometimes more) for the whole season up to this stage and it was clear that an additional person would be a significant benefit during drilling.

#### *Drilling the second hole*

Drilling the second hole began on 16th January. Once again the drilling progressed well, with few problems and hold-ups. As we reached greater depths, the drill monitors again showed hose tensions lower than expected at times. In each case, the sequence of raising the drill then lowering it again appeared to return operations to normal. The only major incident during this period happened when the drill was at 1980 m depth. The hose coupling at about 40 m below the surface failed. Although we had originally expected this to be very unlikely, we had prepared for it anyway and the backup system operated correctly. The prussiks held the hose and stopped it being lost down the hole. The drill was raised, the coupling was fixed and drilling re-commenced.

When the drill reached a depth of 2025 m (136 m above the bed) the hose tension was again lower than expected and we began raising the drill a short distance. During raising, as one of the hose couplings passed over the top of the capstan wheel, it failed. Once again the backup prussik held the hose as planned. We also had a second backup system, which involved manually attaching another prussik to the hose in the drilling pit. As this was being attached, the first prussik failed and 1900 m of hose was lost down the hole, along with the associated drilling nozzle, reamer and data loggers. The time was 20:30 on 17th January. Fig. 12 shows some of the failed or associated items.

#### *Immediate aftermath of the hose loss*

Recovery of the drill hose was not a possibility. Even if we had a system capable of attaching to the failed end of the hose down the hole, the drill nozzle at the bottom of the hole will have frozen to the ice very quickly (<10 minutes), after which we could never have broken it free. The loss of the hose was accepted as final and the rest of the drilling system was decommissioned and switched off. (Later assessments and reports concerning the hose failure are given in Appendix B)

The NASA-JPL borehole video camera was lowered down the hole to locate the top of the hose. This showed it was resting at a depth of 589 m below the surface. Knowing that above this depth the hole was therefore unobstructed, we were able to lower a 300 m thermistor string into the upper part of the hole. This will need to be re-measured next year (2005/06) to give accurate temperature measurements in the upper part of the ice stream, which can be used to indicate recent climate history of this area.

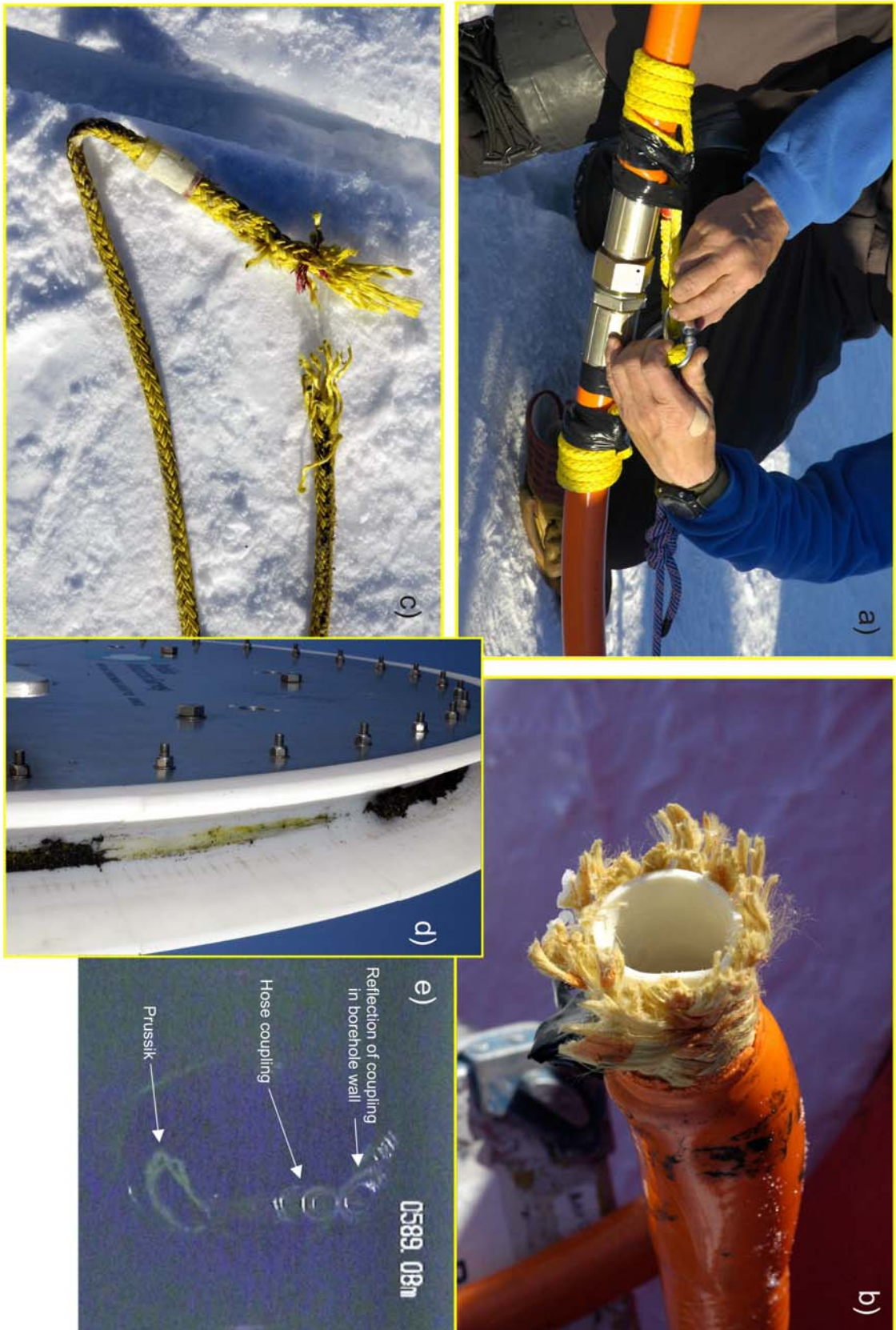

**Fig. 12.** Images to illustrate the hose failure on 17 January 2005. **a)** Example of prussik loops used as a backup in case of coupling failure. **b)** Hose end after coupling failure. **c)** Prussik that failed. **d)** Yellow fibres in the base of the groove show evidence of abrasion to prussik from slippage on the capstan wheel. **e)** Upper end of the drilling hose lost down the hole, in its final resting place (image looking vertically downwards, captured from video taken by NASA-JPL borehole camera). Digital read-out shows depth below surface.

*Analysis of the hose failure and taking stock of possible options*

The couplings between the individual sections of hose proved to be a significant, un-expected weakness in the system. Although we had not expected this to be the case, we had recognised it as a possibility and put backup systems and procedures in place. The hose had been lost because the primary backup had failed.

Close inspection of the failed prussik showed that abrasion had weakened it. The abrasion was caused by the friction material on the capstan wheel, which is used to grip the hose and stop it slipping. Once the coupling failed, the full circumference of the capstan wheel was no longer in contact with the hose and slippage occurred. In the short period between the coupling failing and the capstan wheel being stopped, this slippage was sufficient to abrade the prussik and weaken it to the point of failure.

It appears to have been unfortunate that the coupling failed when it did. Passage over the capstan wheel is a relatively gentle process. The greatest forces on the couplings of the rising hose occur where the hose comes out of the hole and over the jockey wheels that feed it onto the capstan wheel, not on the capstan wheel itself. Hence it is most likely to fail before the wheel, rather than on it. However, it is only on the wheel that there is any risk of abrasion to the prussik.

This was probably the worst possible stage for a hose failure to occur. Had it happened at a shallower depth, we may well have saved enough hose, combined with the spare sections, to drill to the bed again. If it had failed after we had drilled the final 136 m to the bed, we would still have valuable information on the characteristics of breakthrough – i.e. what happens to the water in the hole when the drill actually reaches the bed – and hence some indication of the subglacial hydrological system.

Over the following 3 days we took stock of the remaining drilling equipment and the experiences so far. By combining the remaining hose (1.25”) with narrower hose left over from previous drilling projects (0.75”), we had enough to just reach the bed of the ice stream. However, there were a number of other important issues to consider:

- ▶ Although theoretically this hybrid system was capable of reaching the bed, it was right on the limit of its capabilities. Any heat losses greater than assumed could make it impossible to reach the bed. The operation of the reamer during the previous drilling was an indication that heat losses may well have been slightly higher than expected, which made success seem even less likely.
- ▶ No reaming would be possible and the maximum hole diameter we could reasonably expect (after raising the drill) would be about 12 cm – only half of what we had previously considered our minimum workable value. Hole closure from re-freezing, particularly in the coldest part of the ice column (1400-1800 m depth), would leave very little time to use the hole. There was a significant chance that we might not actually be able to get the instrument string all the way down the hole and any delays would increase this risk.
- ▶ Water pressure in the system would be 1600-1700 psi, more than twice the maximum we had operated at with the main drilling system. The internal pressure in the hose (that trying to force the hose couplings apart) would be around 1000 kg, rather than the 450 kg we had been experiencing so far. This would be only marginally offset by the reduced weight of the hose. The risk of further coupling failure seemed very high. If this were to happen at the surface again, the higher pressures involved would pose a significant danger to anyone close-by.

The risk to people, combined with the added risk of failing to reach the bed or deploy the instruments, led to the decision not to attempt further deep drilling. This decision was taken on 21st January.

### **2.2.3 The final few weeks**

Having decided that there would be no further deep drilling, the plan for the rest of the season became straightforward and concentrated on maximising the remaining science that could be achieved. Early departure was arranged for those with either little need to stay beyond a certain amount of equipment packing, or else with particular need to leave as soon as possible. This reduced the number of personnel to 4 or 5 for the final few weeks of the season.

There were a number of clear priorities to maximise the science we could complete.

- Maintain the GPS network for as long as possible.
- Carry out ground-penetrating radar (GPR) surveys in the area.
- Collect ice cores from selected depths using the hot-water ice corer.
- Complete additional seismic reflection surveys.

- Measure surface elevation profiles along the seismic and GPR lines.
- Set up a GPS receiver and appropriate power system to run un-attended over the winter.
- Complete tests of the passive seismic equipment.
- Prepare a depot to be left at the end of the season

#### *GPS network*

The GPS base stations were collected on 3rd February. They had been running continuously for 35 days. The ice stream network was finally uplifted on 12th February, after running for 58 days.

#### *Ground-Penetrating Radar (GPR) surveys*

GPR profiles were acquired over all the seismic reflection lines. In addition, the cross-stream line was extended 3.6 km towards the mountains and 3.6 km towards Fletcher Promontory.

#### *Ice coring*

A number of strong radar reflecting horizons were identified on the GPR data and their depths calculated. The capstan wheel of the hot-water drill was moved into position where we wanted to drill. Two days were spent on the ice coring (24th and 26th January). Sections of ice core, up to 4m long and 95 mm diameter, were acquired using the hot-water ice corer (Fig 13). The cores were taken from specific depths above, below, or straddling the radar reflecting layers. The cores were logged, cut into 55 cm sections, sealed in lay-flat plastic tubing, packed in foam and placed in insulated core boxes. A total of 21.04 m of ice (6 separate cores) was collected, of varying quality. The core boxes were stored in a cave cut in the snow 2 m below the surface until they could be returned on cold-deck flights to the freezers at Rothera. The ice was returned to frozen storage in the UK and will be analysed for physical and dielectric properties.



**Fig. 13.** Hot-water ice coring. **a)** Good quality 4 m length of core from ~90 m depth. **b)** Tapered end of ice core extending beyond the bottom of the barrel.

This is only the second time we have used the hot-water ice corer and we made a number of useful observations:

- In good conditions a full length of excellent-quality, full diameter core can be acquired (Fig 13).



- Once a section of core has been taken, the next few metres of ice below it will have been too disturbed to be retrievable. This next ~1 m needs to be drilled away before deeper ice can be successfully retrieved.
- A deep, sloping notch melted into the snow at the side of the capstan makes deployment and retrieval of the 4m-long corer much easier.
- A good core section would often extend up to 10 cm beyond the bottom of the coring barrel (Fig. 13), making them slightly longer than the expected 4 m maximum.

#### *Additional seismic reflection lines*

As there were sufficient time, fuel and explosives remaining, we took the opportunity to complete two more seismic reflection lines (see Fig 5 for locations). With the hope of perhaps securing resources to complete the deep drilling in the future, we completed an along-flow line (Rabid Line), crossing the first line at the point we had identified as the second drilling location. A final, along-flow line (Tolly Line) was acquired along the crest of a mound of deforming sediment at the ice stream bed.

#### *GPS profiling*

Kinematic GPS surveys were used to measure the surface profiles along the seismic and GPR survey lines, as well as giving position fixes for the line end-points. A base station was set up at a fixed point (usually the start of the first seismic line) and roving receivers mounted on skidoos or sledges.

#### *Over-winter GPS station*

One GPS receiver was left running at the end of the project, to be collected next season (2005/06). It is hoped that this will keep running throughout the winter and spring and will give a long-term record of the ice flow at this site, indicating any possible seasonal variability. The receiver we left was a Trimble 5700, as this has the lowest power consumption of those available to us.

The power system was provided by BAS PSD engineers and was a modified version of the design used in recent years to run Low-Power Magnetometers deployed at remote locations in East

Antarctica. It uses two wind generators, a 45 W solar panel and four, 100Ah gel cell batteries to provide power. A Dump Box regulates the power and dissipates any excess power from the wind generators in high winds. The solar panel, wind generators and dump box were mounted on scaffold poles guyed out to snow stake anchors (Fig. 14). The GPS antenna was mounted on a tripod with the legs buried in the snow. The battery boxes and receiver were buried in 1-2 m-deep pits to minimise the effect of the cold winter temperatures.



**Fig. 14.** Overwinter GPS station deployment. Boxes containing batteries and receiver are already buried.

#### *Passive seismic equipment*

By this stage, we had long accepted that we were not going to acquire any useable passive seismic data. A final suite of tests were completed, for which the primary intention was to ensure we had sufficient information to enable the NERC GEF team to consider how to upgrade the ISSI instruments. Hopefully they can be modified to make them appropriate for glaciological projects in the future. The two Reftek

recorders were operated intermittently at two locations to give some indication of whether basal seismicity has changed since earlier experiments.

#### *The new RABID Depot*

A considerable amount of fuel still remained at the end of the season. As future work for the drilling equipment was still uncertain, BAS Operations had agreed that the hot-water drilling equipment depot should remain at RABID too, rather than being redeployed at this stage. The fuel and equipment were consolidated into a single depot, but if the equipment depot is to stay there for a number of years, it may be better to separate them to ease use of the fuel depot for aircraft operations. (At the time of writing (early 2006) the depot has been re-visited and separated. Full details of the new depots are available at Rothera or from BAS Operations Group.)

#### *Crevasse*

One of the crevasses close to the old RABID Depot was investigated during the last few days of the season. All the crevasses in this area were still well-bridged and very difficult to identify on the ground. One was entered by digging through the bridge in two places, where it was around 1-2 m thick. The crevasse was around 1 m wide at the top, widening in the top few metres to around 5 m. A rope was used to show that it was approximately 50 m deep and we estimated it was at least a few hundred metres long (and possibly even more than 1 km), orientated roughly in the direction of ice flow.

#### **2.2.4 Final uplift**

The final uplift flights out of RABID occurred on 19th and 20th of February. The maximum time spent in the field had been 95 days. The last people arrived at Rothera on 21st February. For the remaining science personnel, three days were spent at Rothera completing a number of final tasks:

- Packing and consigning cargo and ice cores for north-bound transport.
- The annual end-of-season survey of Rothera Ramp.
- Inventory of explosives and detonator stocks, and assessment of storage facilities.

---

## **3. EQUIPMENT**

### **3.1 Hot-water drill**

The BAS hot-water drill has evolved over the last two decades. It has previously been used very successfully to access the oceanographic regime beneath George VI and Ronne ice shelves, as well as for glaciological measurements in the shear margin between Rutford and Carlson ice streams. Prior to RABID the maximum depth it had drilled to was around 1000 m. One of the major tasks for the RABID project, in preparation for the field season, had been to upgrade it to 2.5 km capability. This had been achieved over a number of years and much of the new system had been tested (though not to the maximum depth) during BAS fieldwork on Ronne Ice Shelf.

#### *The RABID Drill*

The basic equipment of the RABID Drill comprises:

- 16 oil-fired heat exchangers.
- Four triplex, ceramic plunger water pumps.
- Four diesel generators (10 kVA each) plus small petrol generators.
- Two 12,000 litre water flubbers.
- Three submersible water pumps (66 l/min each).
- ~1.5 m diameter capstan wheel in aluminium frame, driven by electric motor.
- Two hose take-up drums (each capable of holding up to ~450 m hose), driven hydraulically.
- 3000 m of 1.25" diameter thermoplastic hose, in 200 m sections.
- Associated hoses, fittings manifolds etc.

- A number of spare heaters, pumps and generators were also available.

Specifications and operating parameters:

- Total Power: 1 MW
- Maximum Operating Pressure during RABID: 800 psi
- Maximum Flow Rate: 135 l/min
- Fuel consumption – full system: approx 200 l/hour
- Water temperature:
  - ▶ 85-95°C at surface
  - ▶ 50°C at 2000 m depth
- Typical drilling rate in ice:
  - ▶ 2.0 m/min at 700 m depth
  - ▶ 1.2 m/min at 2000 m depth

Fig. 15 shows the RABID drill set up and ready for use

### 3.2 Seismic reflection equipment

The seismic reflections surveys were almost identical to those carried out by BAS glaciologists for a number of years. A brief outline of the equipment follows, details can be found in BAS field reports.

#### *Acquisition*

Seismic Recorder: BISON 9024, 24 channel. (This recorder has been used virtually every season since it was purchased in 1990. RABID was probably its final task. Although it performed well, it is probably now well beyond its working life and will be replaced soon.)

Cable: 24-channel, analogue cable; take-out spacing 10m ; lead-in 30 m at each end.

Blaster & Trigger:

- Initially, we used the BISON 1430 single-cap blaster. This failed partway through the season
- For the rest of the season we used a Pelton Shot-Pro blaster and GPS shotbox trigger.

#### *Drill*

- Oil-fired heat exchanger (75 kW). Failed after 3 days operation, replaced by equivalent unit from the main RABID hot-water drill.
- Triplex, ceramic plunger water pump (15 l/min capability)
- Honda EU10i generator
- ~300 litre water tank (modified Zarges box)
- 3/8" hose (rubber-coated steel braid)
- 1.5" diameter drill nozzle

All this mounted neatly on one komatik sledge.

#### *Explosives and detonators*

Explosive types: Trojan 6L (150 g) and Austin Powder (1kg) Pentolite cast primers

Charge sizes:

- ▶ 300g for standard reflection work
- ▶ 1 or 2 kg for long record shots

Detonators: Rosbusky seismic electric detonators, 10 m lead wires.

### 3.3 GPS

We had three different types of survey-spec GPS receiver with us:

- 5 Trimble 4000 series receivers
- One Trimble 5700 receiver
- Five Leica 530 receivers, on loan from the NERC Geophysical Equipment Facility (GEF)

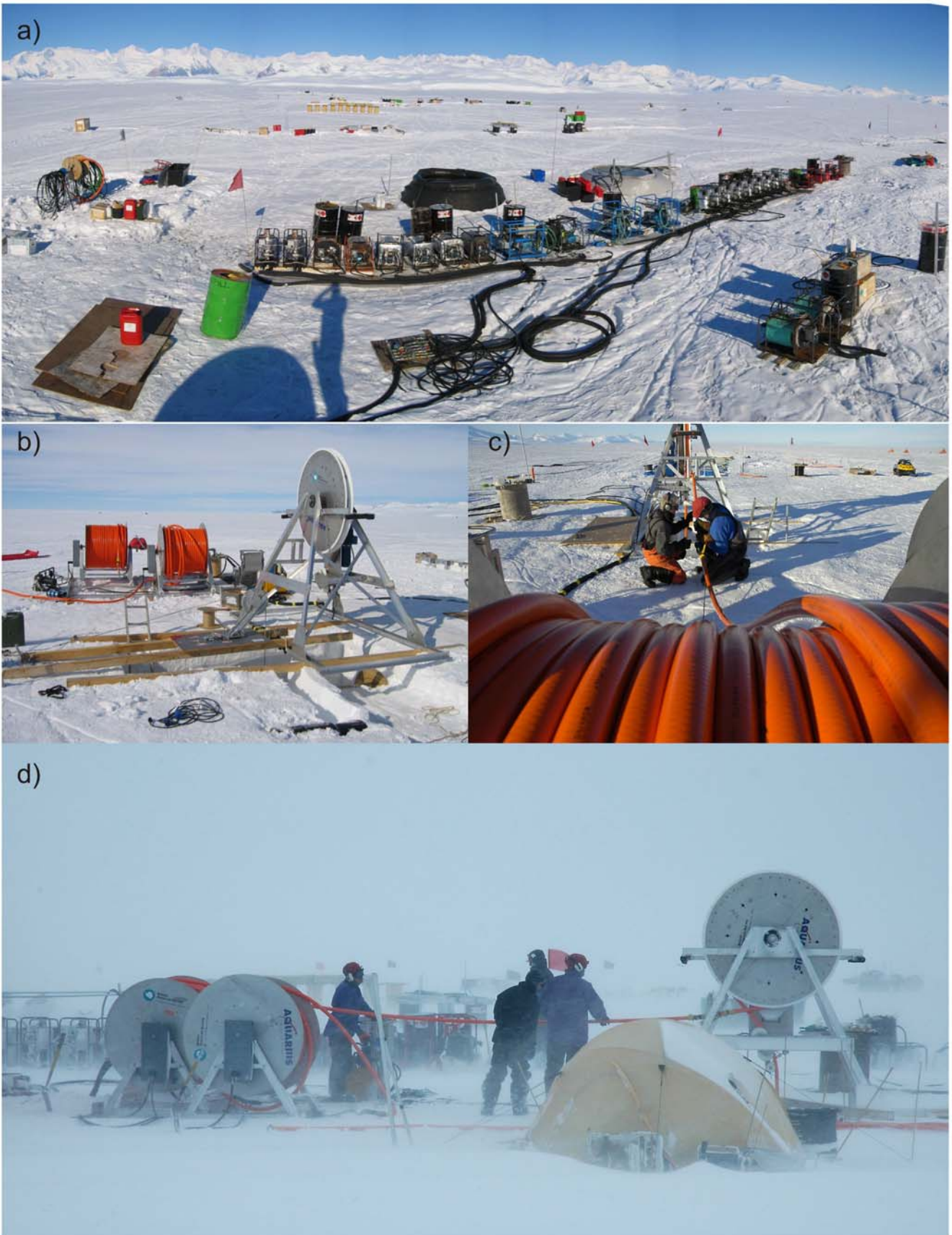

**Fig. 15.** The RABID drill set up ready for use and during drilling operations. **a)** Layout of burners, pumps, generators and flubbers. Fuel drums are in place behind the burners. Equipment and fuel depots can be seen in the distance. **b)** Hose drums and capstan wheel in place over drilling pit. **c)** Drilling hose feeding off drum and onto capstan wheel. Photograph taken during a hose change-over. **d)** Drill in operation during the poor weather of 10 Jan 2005.

Apart from minor cable problems early on, all these receivers performed well. Data were recorded on 1GB flash cards in the Leica and 5700 receivers. The Trimble 4000 receivers log data to their internal memory.

Two Leicas were used for base stations, powered by two 70 Ah wet, lead-acid batteries, and single 40W solar panel, with appropriate regulator.

The ice stream network was three Leicas, the Trimble 5700 and one Trimble 4000. Power at each station was from a 100 Ah gel lead-acid battery, 40 W solar panel and regulator.

#### *Overwinter GPS system*

The Trimble 5700 receiver was left running over the winter, logging to a 1 GB flash memory card. The power system comprises:

- Four 100 Ah gel, lead-acid batteries,
- One 45W solar panel
- Two vertical axis wind generators
- Appropriate regulator and energy management system

### **3.4 Passive seismic equipment**

#### *ISSI equipment from NERC GEF*

The main passive seismic equipment was 14 separate recording stations, supplied by NERC GEF. Each one contained:

- ISSI SAQS seismic data logger (with GPS)
- 4.5 Hz three-component geophone
- Three-component accelerometer
- One 100Ah gel lead-acid battery
- 40W solar panel
- Regulator

Additional equipment included associated computing & data storage plus a complete spare station.

#### *Reftek*

We also had two older, BAS Reftek passive seismic stations, originally taken with the intention of leaving one deployed over the winter.

Each comprised:

- Reftek DAS model 72-A-07/G/ND (with GPS).
- Reftek hard disk model 72A-05.
- 4.5 Hz three-component geophone.
- Power system as for the ISSI SAQS above.

### **3.5 Ground-Penetrating Radar (GPR)**

We used a Malå RAMAC GPR system with 200, 100 and 50 MHz unshielded antennas, provided by Leeds University. The 100 MHz antennas could be used in cross-polarised and both in-line and cross-line configuration in a single survey, via a multiplexer.

### **3.6 Power**

In addition to specific items dedicated to other equipment (eg the hot-water drill generators), we had a number of sources of electrical power:

- Honda EU20i 2kW petrol generator (1)
- Honda EU10i 1kW petrol generator (2)

- 70 Ah wet, lead-acid batteries (8)
- 100 Ah gel lead-acid batteries (numerous)
- solar panels (mostly 40W)

The generators provided virtually all the power required by the camp, for both domestic and science needs. Generally they performed very well. The only times when the camp used additional power was during drilling periods when we took power from the drill generators to run the water-urn and electric oven.

### 3.7 Weather Station

An ONSET HOBO weather station (provided by NASA-JPL) was operated at the camp from 30 December 2004 to 20 February 2005. Temperature, pressure, wind speed and direction, solar radiation and relative humidity were logged.

### 3.8 Thermistor string

The thermistor string was approximately 300 m long with ten 3K3A Betatherm thermistors spaced at 31.5 m intervals. The thermistors had been calibrated in 1993 using a salt water bath over temperatures ranging from  $-12^{\circ}\text{C}$  to  $+21^{\circ}\text{C}$  and were recalibrated prior to the field work in stable air temperatures at  $-28^{\circ}\text{C}$  and  $+19^{\circ}\text{C}$  and in an ice point bath. Once the thermistor cable had been deployed the hole was back filled with snow to cover all but the uppermost thermistor. After one year the thermal regime of the ice will have recovered from the drilling and the ice temperature can be measured.

### 3.9 Instrument strings

Each instrument string consists of a 2.5 km, five-core cable with twelve instrument units mounted along its length. Each unit is a pressure case containing a two-axis tilt-sensor, a temperature sensor, a pressure sensor, and all the necessary A/D converters and controllers. The units are distributed along the cable according to the modelled velocity profile of the ice column, with most of the instruments at the bottom end of the cable and an instrument separation rapidly increasing to 500 m for the majority of the upper part of the ice.

The logging system comprises an interface box and a Campbell Scientific 10X data logger. The interface converts the RS485 protocol used to communicate with the instruments to RS232 protocol that can be read by the logger. A 12V SunLyte gel battery was to power the entire system. While the complete dataset was to be stored on memory modules, a subset of the data could be sent over a satellite data link via an Argos transmitter connected to the data logger. All sensors on all instruments were to be logged every 15 minutes.

### 3.10 Sediment coring

A gravity sediment-coring system was bought from UWITEC (Mondsee, Austria). A variety of different possible assemblies were available, to allow us the maximum options and flexibility in the field. However, the basic system we intended to use comprised the following:

- ▶ Stainless steel 3m barrel, outer diameter 70 mm, wall 3mm.
- ▶ PVC liner, outer diameter 63.5 mm, wall 1.8 mm.
- ▶ Cutters, catchers, drill head and hammering mechanism.
- ▶ Maxibraid 4mm Kevlar rope (breaking strength  $\sim 1300$  kg)

### 3.11 Tethered stake

The tethered stakes are a modified version of the Cal-Tech design and we are grateful to Hermann Engelhardt for his assistance. The instrument consists of an anchor that is deployed into the sediment beneath the ice. The anchor is attached to a thread, which feeds off a bobbin in a monitoring unit. This

monitoring unit sits inside a tube that remains in the borehole, close to the base of the ice. The whole assembly is lowered together down the hole. When it reaches the bed, the impact of inserting the anchor into the sediment releases it from the rest of the assembly, which is then withdrawn a short distance back up the borehole. If there is any differential motion between the ice and the bed (basal sliding), the separation between the anchor and the monitoring unit will increase and thread will be drawn off the bobbin. This is detected by the monitoring unit, which sends a signal (a simple pulse) back up to the surface for every quarter revolution of the monitoring unit rotor (diameter 31.6 mm). A data logger at the surface records the number of pulses, which can then be integrated to give the basal sliding rate.

The tethered stakes were produced by Andy Tait of BAS's Engineering Technology Section. Three complete instruments were constructed. One was used in a test deployment on Gornergletscher, Switzerland, in collaboration with Martin Funk, ETH, Zurich. The others were to be deployed at the two RABID drill sites.

## 4. PRELIMINARY RESULTS

### 4.1 Seismic reflection

Brute stacks of the first two seismic reflection lines (those used to locate the drill sites) are given in Fig. 4. Tyree04 Line covers the same section of the ice stream bed (geographically) as part of some earlier (1991-92 and 1997-98) surveys and a comparison of these three data sets is showing some remarkable results (Fig. 16). Between the first two surveys, 6 m of bed material was eroded from a 500 m wide region of the bed. This mean erosion rate of  $1 \text{ m a}^{-1}$  is orders of magnitude greater than even the highest rates normally expected in the subglacial environment. Between the second and third surveys this erosion ceased and a large mound of sediment (10 m high, 100 m wide) was emplaced. The Rabid Line seismic reflection data show that this mound is at least 1 km long in the upstream direction. The acoustic impedance of the bed material (an indication of how soft or hard it is) shows this mound is soft, water-saturated deforming sediment (Fig. 16). We interpret this as an actively-forming drumlin – the first time this process has been observed. The acoustic impedance data also show other changes in the basal conditions with time:

- Mobilisation of former non-deforming sediment by increased water content and pressure (A in Fig. 16).
- Increased compaction and de-watering of basal sediment (B in Fig. 16).

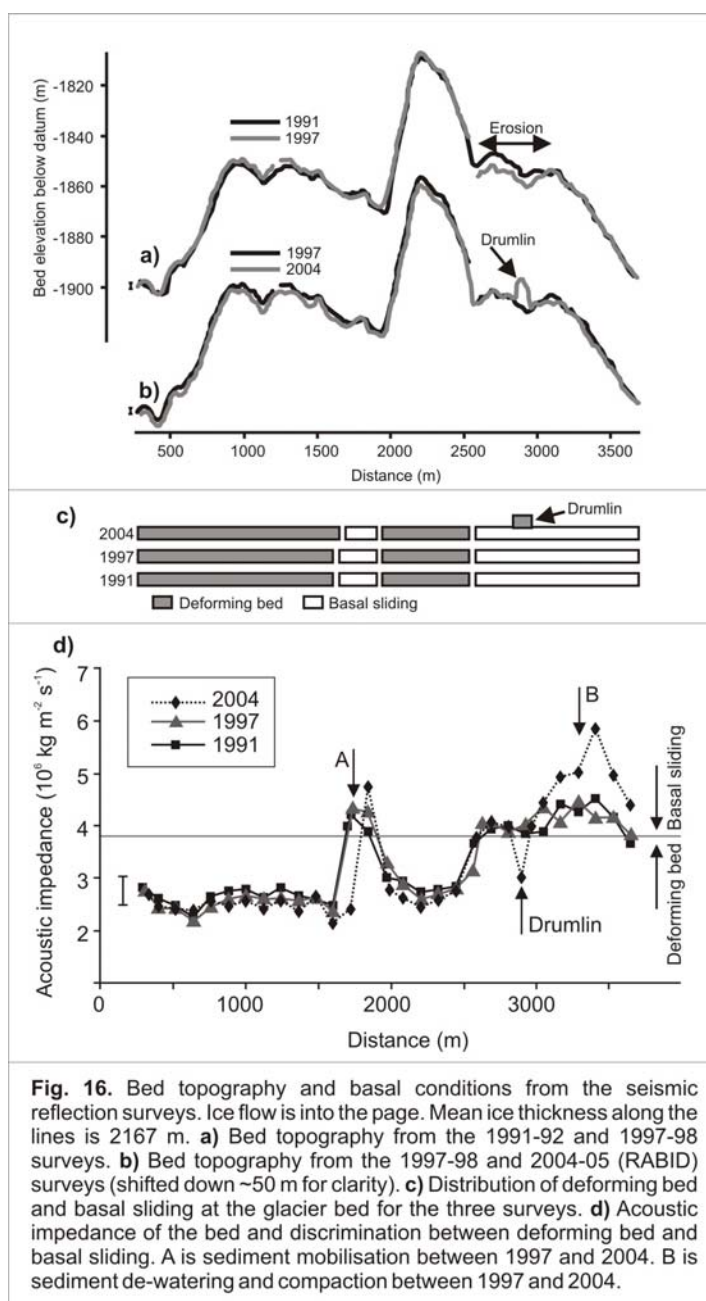

**Fig. 16.** Bed topography and basal conditions from the seismic reflection surveys. Ice flow is into the page. Mean ice thickness along the lines is 2167 m. **a)** Bed topography from the 1991-92 and 1997-98 surveys. **b)** Bed topography from the 1997-98 and 2004-05 (RABID) surveys (shifted down ~50 m for clarity). **c)** Distribution of deforming bed and basal sliding at the glacier bed for the three surveys. **d)** Acoustic impedance of the bed and discrimination between deforming bed and basal sliding. A is sediment mobilisation between 1997 and 2004. B is sediment de-watering and compaction between 1997 and 2004.

## 4.2 GPS

Preliminary processing of the GPS data was completed by Matt King, University of Newcastle (Fig.17). Guðfinna “Tolly” Aðalgeirsdóttir (University of Swansea) has completed the full data processing. The base station in the Ellsworth Mountains (Tolly’s Heel) was particularly useful, easing the processing and giving good data from the ice stream network. Mean velocities at each site are given in Fig. 18.

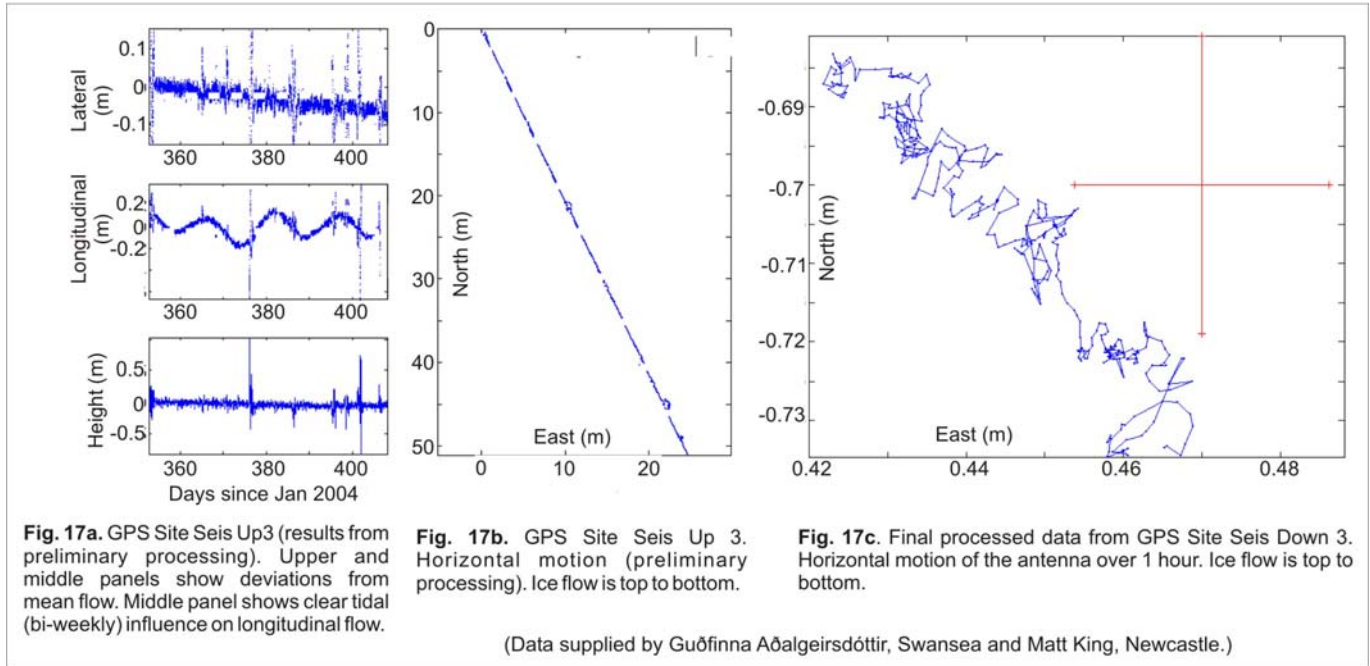

At each site on the ice stream, the long term motion ( $\sim 380 \text{ m a}^{-1}$ ) is modulated by a roughly fortnightly signal of up to 25% of the total velocity. Comparison with the ocean tides at the grounding line of Rutford Ice Stream shows that this signal appears to be related to the spring-neap ocean cycle. This confirms earlier GPS observations from closer to the grounding line of Rutford Ice Stream, which showed a similar tidal modulation. Our data show that the amount by which the ice speed is modulated by this tidal signal varies across the network, a phenomenon not previously observed (Fig. 19). These data contrast with recent observations from some of the Siple Coast ice streams, where a pronounced stick-slip motion has been observed, linked closely to the diurnal tidal cycle.

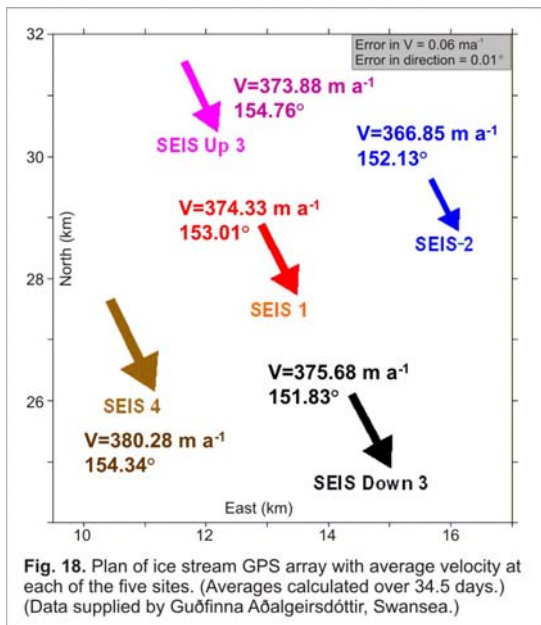

## 4.3 Passive seismics

No useable data were acquired with the NERC GEF ISSI instruments. Fig. 8 shows basal events recorded by the Refteks compared with the corresponding ISSI data. This confirms that the problem was with the ISSI sensitivity, rather than merely an absence of events. However, further scrutiny of the Reftek data is also potentially interesting. Previous work in this area had identified regions of the bed that were relatively noisy or quiet. One of the noisy sites was chosen for the ISSI-Reftek comparative tests, to maximise the number of events expected. Although the tests were successful, the number of events recorded by the Refteks was far fewer than expected (mean of 18 events per day, compared with 135 previously at this site). This proved to be consistent with the results of the seismic reflection surveys acquired both during RABID project and in earlier field seasons. These showed that during the previous passive seismic experiment, the ice stream bed at this particular site was being eroded (or just ending a period of erosion). Subglacial erosion is expected to be a relatively noisy process, as supported by the high level of basal seismicity at that time. The Tyree04 seismic reflection data acquired during RABID (Fig. 4) showed not



only that the erosion had ceased, but that a mound of soft, deforming sediment had formed at the bed. A deforming bed is expected to be relatively quiet and the cessation of erosion plus the new mound of soft sediment may explain the fall in seismic activity.

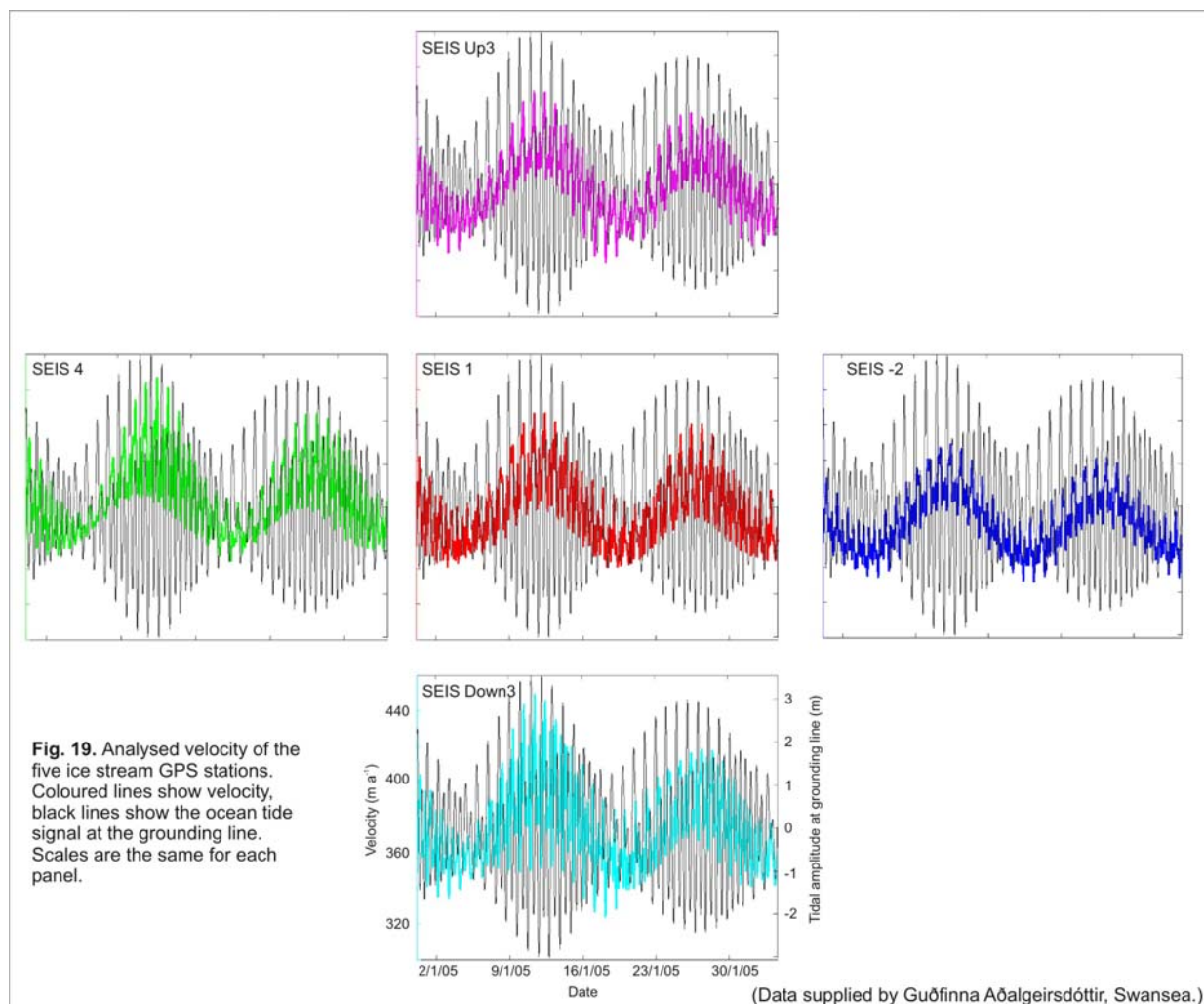

#### 4.4 GPR

A preliminary look at the GPR data show a similar overall pattern to earlier profiles in this area (Fig. 20). One of the principle uses of the GPR surveys during the season was to choose specific targets within the upper 100 m of the ice stream where we should collect ice cores.

#### 4.5 Weather

The data logged by the JPL weather station are shown in Fig. 11. Rutford Ice Stream is well known for often having long spells of good weather, particularly during the middle part of the summer. This season was exceptionally good, even for the Rutford. We had very long periods of good weather – clear, calm and not too warm or cold. Winds rarely rose above 5 m/s. Storms were rare, short (no more than 2 or 3 days) and not particularly severe. Daytime temperatures were around  $-5^{\circ}\text{C}$  to  $-10^{\circ}\text{C}$  for most of the season, only getting significantly colder towards the end. Temperatures dropped below  $-25^{\circ}\text{C}$  only on a few days in February.

One other unusual feature of the weather was the speed with which it deteriorated at the end of the first drilling period on 10th January. Wind speed increased from calm to 14 m/s over only  $\sim 30$  minutes; the temperature rose to around  $-2^{\circ}\text{C}$ , staying quite warm for a couple of days after that; and the humidity rose rapidly to 98%.

#### 4.6 Preliminary scientific conclusions

- No stick-slip motion is seen in the flow of Rutford Ice Stream. This contrasts with results from ice streams elsewhere in West Antarctica.
- There is a strong correlation between ice stream velocity changes and ocean tides at the grounding line.
- The amplitude of the tidal modulation on ice flow decreases upstream.
- This amplitude decay with distance is more rapid for the higher frequency constituents (diurnal and semi-diurnal) than for the longer period ones (MSF). This indicates a non-linear response to tidal forcing.
- Monitoring subglacial seismic activity can indicate changes in basal conditions.
- Operationally, the GPS survey procedures proved effective and yielded good quality data.
- Although the ISSI instruments gave no useable data, operationally they performed well. Once the sensitivity issues are resolved, these should be good tools for glaciological research.
- Basal conditions can vary rapidly.
  - ▶ Extreme rates of subglacial erosion ( $1 \text{ m a}^{-1}$ ) can cease and be replaced by the formation of a drumlin over a period of a few years or less.
  - ▶ Movement of significant quantities of water within the sediment at a glacier bed has been observed.
  - ▶ Both mobilisation and compaction of basal sediment have been observed.
- The theory of drumlin formation by fully-mobilised sediment is shown to be correct, in this case at least.
- An ice stream appears to be capable of reorganising its bed rapidly, suggesting that present ice dynamic models do not yet simulate all the relevant subglacial processes.



**Fig. 20a.** GPR surveys. Radar antennas are in the foreground; GPS antenna can be seen mounted on the sledge; temporary GPS base station is on the left of the picture.

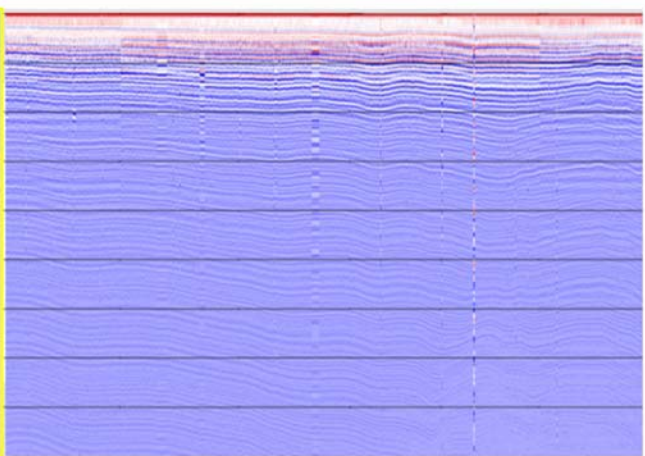

**Fig. 20b.** Example of typical GPR data collected in the area around RABID. Ice flow is into the page. Data processing is still to be completed. Section length is approximately 10 km, maximum depth is approximately 100 m.

#### 4.7 Data Management

Multiple copies of all raw data are held at both BAS and Swansea. We are liaising with the Antarctic Environmental Data Centre (AEDC) - NERC's relevant designated data centre – who are currently in the process of clarifying what data they require us to submit to them, and in what format. We expect to be submitting this to AEDC some time in 2006.

## 5. RECOMMENDATIONS

### Note:

1. These are the comments of the author, not necessarily those of the full RABID team.
2. They are a selection of current thoughts, not a fully comprehensive list of proposed improvements.

Prior to any project attempting to achieve the RABID objectives, the following are worth considering:

- Improve hose & couplings (and back-up systems, as appropriate).
- Increase size of take-up drum, so single drum will take full 2200 m of hose. This should still be possible with something built up from individual pieces that will fit inside a Twin Otter.
- Longer sections of hose – if this makes them too big for Twin Otter transport, consider skidoo train from Sky-Blu
- A third flubber.
- Improve thread bobbin in tethered stake.
- Fill system with antifreeze, using a separate system if necessary.
- Fletcher Promontory base station is not necessary.
- Improve sensitivity of passive seismic ISSI loggers (perhaps preamplifiers will solve this).
- Increase field team to at least 8.

---

## ACKNOWLEDGEMENTS

Funding for RABID was provided by AFI, BAS and NASA-JPL. Murray was supported by a Leverhulme Trust Fellowship. Excellent support was received from the BAS Air Unit and Operations Group. Thanks go to all the individuals who have contributed to RABID.

# RABID

---



## SLEDGE JULIET FIELD REPORT

Rutford Ice Stream, West Antarctica  
November 2004 – February 2005

R/2005/K7

Author: **Alex Taylor, FGA**

Distribution: 1. F.O.M  
2. Rothera Library  
3. BAS HQ  
4. Author

## TABLE OF CONTENTS

SUBJECT	PAGE
1.0 INTRODUCTION	1
2.0 ABOUT RABID AND THE RUTFORD ICE STREAM	1
2.1 Rutford Ice Stream	
2.2 Weather Patterns	
2.3 Travel Conditions	
3.0 The RABID Project 2004/2005	4
3.1 Daily Field Diary	
3.2 Depot Recovery	
3.3 Reflection Seismics	
3.4 Deep Drilling Process	
3.5 GPS Locations	
4.0 DEPOTS	6
4.1 RABID Depot February 2005	
4.2 Notes on Flags and Glacio Poles	
4.3 RABID Depot 2003/2004	
4.4 Aircraft Returning from 2005 Input Flights	
4.5 Depot Raising Methods and Recommendations	
4.6 Depot Reporting Practices	
5.0 LIVING UNITS / STATIC CAMP OPERATIONS	8
5.1 Static Camp Kitchen/Dining Set Up	
5.2 Weather Haven Tents	
5.3 Generators	
5.4 Power Cables	
5.5 Snow Melt Tank	
6.0 ENVIRONMENTAL MANAGEMENT	10
6.1 Waste Management	
6.2 Food Waste	
6.3 Toilets and Pee Flags	
6.4 Fuel Handling	
7.0 FIELD COMMUNICATIONS	11
7.1 Radio Operators	
7.2 Feedback	
7.3 PRM Radio	
7.4 100 Watt Radio	
7.5 VHF Radios	
7.6 FRS Consumer Band Radios	
7.7 Aero VHF Radio	
7.8 Iridium Satellite Telephones	
8.0 TRAVEL UNITS	14
8.1 Ski-Doos	
8.2 Ski-Doo Notes for 2005/2006	
8.3 Ski-Doo Numbers	
8.4 GPS Mounts	
8.5 Sledges	
9.0 CLOTHING & EQUIPMENT	17
9.1 Depot Raising /Drum Handling Equipment	
9.2 Honda Snowblower	
9.3 Pyramid tents	
9.4 Cables and Reels	

SUBJECT	PAGE
10.0 AIR OPERATIONS	19
11.0 HEALTH AND SAFETY	20
12.0 FGA PLANNING AND PREPARATION FOR STATIC CAMP FIELD PROJECTS	21
13.0 GPS BASE STATIONS	21
14.0 MAPS AND SATELLITE IMAGES	22

## APPENDICES

- Appendix A – Map of Ellsworth Mountains and Rutford Ice Stream 1:200,000
- Appendix B – Map of Flowers Hills and Tolly's Heel/GPS Base Station Location 1:50,000
- Appendix C - Diary of Events for Field Season
- Appendix D – Depot Diagram 2005 (*Not with this copy*)
- Appendix E - DEPOT Diagram 2004 (*Not with this copy*)
- Appendix F – List of Recommendations
- Appendix G – Report Photographs (on CD) (*Not with this copy*)
- Appendix H – Depot Contents List
- Appendix I – Static Camp “Tent Box” Contents
- Appendix J – Clothing and Equipment Recommendations

## RABID INDEX

Total Number of Days in the field season - **95**  
Number of person-days in the field - **474**  
Highest number of people in camp at any one time - **11**  
Average Number of people in camp throughout the season - **6**  
Number of Storm Days in the field season - **6**  
Number of days when the wind was above 20 knots - **7**  
Number of days when the wind was between 10 and 20 knots - **21**  
Number of days when the wind was between 5 and 10 knots - **35**  
Number of days when the wind was calm (0-5 knots) - **32**  
Lowest recorded air temperature - **-30°C**  
Highest recorded air temperature - **-2°C**  
Average velocity of the surface ice on the Rutford Ice Stream, per day - **1m**  
Average thickness of the ice stream, between the surface and the bedrock - **2.1 km**  
Approximate Dimensions of the Rutford Ice Stream - **200 km x 30 km x 2.2 km**  
Elevation of the Rutford Ice Stream at RABID Camp - **330m a.s.l.**  
Elevation of Vinson Massif, Antarctica's highest mtn - **4897m**  
Distance from the Rabid Camp and the summit of Mt. Vinson - **50 km**  
Approximate weight of equipment flown to RABID before the 2004/2005 season - **13 tonnes**  
Approximate weight of equipment flown to RABID for the 2004/2005 season - **16 tonnes**  
Depth below the snow surface the over-wintered fuel drums were buried by Dec. 2004 - **1m**  
Distance (one way) the depot needed to be moved once it was dug up - **6km**  
Minimum number of return ski-doo trips required to move all the fuel and equipment from depot to drill site - **70**  
Total Number of Twin Otter aircraft visits to RABID this season - **40**  
Number of input flights - **15**  
Number of uplift flights - **10**  
Number of avtur drums delivered by aircraft this season - **53**  
Number of avtur drums consumed from Rabid Depot, by aircraft, this season - **45**  
Number of avtur drums consumed by main hot water drill - **53**  
Number of Empty fuel drums sent to Rothera for disposal - **33**  
Number of Empty fuel drums sent to Pine Island Camp for re-use - **32**  
Number of Empty fuel drums remaining in the RABID depot - **30**  
Number of 45 gal. Drums of waste used for Landfill containers - **7**  
Number of avtur drums depoted in the RABID Depot in February 2004 - **215**  
Number of avtur drums depoted in the RABID Depot in February 2005 - **155**  
Total number of Ski Doo Kilometers traveled in 2004/2005 Rabid Season - **4192 km**  
Greatest distance traveled by any one ski-doo at the end of the season - **1716 km**  
Liters of petrol Consumed by Ski Doos and small Honda Generators - **1025 L**  
Minimum number of bread loaves baked in the bread maker - **40**  
Manfood Boxes Consumed - **18**  
Manfood Boxes Opened and not finished (end of season) - **4**  
Number of folding chairs in camp - **8**  
Unit cost of each folding chair - **£4**  
Number of deep holes (>500m) drilled his season - **2**  
Average diameter of deep holes - **20cm**  
Total depth of holes drilled with the large hot water drill rig - **4900m**  
Total depth of holes drilled with the seismic hot water drill rig - **3160m**  
Average diameter of seismic holes - **7 cm**  
Length of high pressure hose lost forever down the second large drill hole - **2000m**  
Approximate Depth of the broken end of the hose, found by the Nasa video camera - **500m**  
Days after it was no longer needed that the NASA cable reel winch was flown to Rothera from Stanley - **28**  
Number of Reflection Seismic Lines Completed - **4**  
Distance of Reflection Seismic Lines Completed - **14.4 km**  
Number of explosive charges detonated for Reflection Seismics - **158**  
Number of 20m deep holes drilled for Reflection Seismics - **158**  
Approximate Length of Ground Penetrating Radar Lines completed - **28**  
Number of minor injuries requiring medical intervention - **1 (broken thumb)**  
Depth, width and length of crevasse discovered near RABID Depot at end of Season - **50m, 8m, 4km**  
Estimated Number of similar crevasses parallel to the one discovered - **30+**

# RABID / SLEDGE JULIET FIELD REPORT 2004-2005

---

## ABOUT THIS REPORT

This report covers the 2004-2005 field season of Sledge Juliet – the RABID Drilling Project on the Rutford Ice Stream. As such it is biased in its description of the needs of a static drilling project, rather than a traditional BAS traveling season. This report has been written with the incoming GA in mind, and for people who may not have worked in the Rutford Ice Stream area before.

This report has been submitted in both paper and electronic form. Some elements of the electronic form will have items not possible to provide in the paper version – such as the extensive selection of colour photographs to illustrate ideas and points in the text.

## 1.0 INTRODUCTION

The time they are a changin' for field parties in BAS. The systems we have traditionally employed could use some significant rethinking. Historically BAS has utilized a large number of small, mobile field parties to get its science and surveying done and our systems of living and travel were designed very well around this fact. In the last few years, however, a trend has arisen towards a smaller number of static field projects requiring huge resource commitments. While the equipment and techniques developed for the mobile field party over decades will always form the core of BAS field operations (eg. Nansen sledges and the unit box system), different equipment and methods for large static projects are required.

Portable snowblowers, Komatik sledges and 3-person tents are but a few of the items that should be gaining in prominence for static camp work. They save energy, are safer, more comfortable, and better designed for most applications than their older counterparts. They may also have many benefits within the traditional travel systems.

## 2.0 ABOUT RABID and the RUTFORD ICE STREAM

RABID is not an acronym. At least that's not what Andy Smith says, and he dreamed it up. Apparently it is just a name, and every project needs a good name if it is going to get funding.

## 2.1 RUTFORD ICE STREAM

The Rutford Ice Stream is approximately 20-30kms wide, 200 kms long and over 2km thick. It flows at a rate in excess of 1m/day (400m+/year). Standing on the surface the terrain appears flat but has subtle undulations (measured in kilometers) across both its width and length. To the west (upstream) and east (downstream) the horizon is featureless. To the north the Fletcher Promontory runs along the full length of the ice stream and appears as a low hill. In the opposite direction, to the south, rises the spectacular and beautiful Sentinal Range of the Ellsworth Mountains, dominated by 4000m peaks like Mt. Tyree, Shin and Vinson Massif. The mountains clearly dominate the landscape and appear quite close, when in fact from the middle of the ice stream the first peaks of the front ranges are over 25km away and the summit of Vinson is over 50km distant. Nonetheless, it is these truly gorgeous mountains that are the backdrop to working on the Rutford and provide constant inspiration and awe with the changing light and weather.

## 2.2 WEATHER PATTERNS

Climatically speaking, a summer on the Rutford Ice Stream is a very pleasant experience. In contrast to the BAS sites on the Antarctic Peninsula where the weather is punctuated frequently by high winds and wet storms, the Rutford Ice Stream is dominated by dry, fair weather more typical of continental conditions. High winds (>20 kts) are rare and calm days are frequent.

**Spring:** November – early December. Temperatures range between –10°C and –30°C. Light to moderate winds only. Occurrence of poor weather more probable than mid-summer.

**Summer:** Mid December – late January. Temperatures range between 0°C and –20°C. Occurrence of poor weather uncommon. Temps frequently in single digits (negative) for weeks. Light winds and calm days dominate.

**Fall:** Late January – February. Temperatures range between –10°C and –30°C, especially from the



beginning of February onwards. Light to moderate winds most common but stormy weather more common as February progresses.

### **Daylight**

The sun is above the horizon for 24hrs starting in early November and stays up above the horizon of Ellsworth Mountains until mid February.

**Wind:** wind speeds are rarely strong and frequently calm, except during storms, of course. The prevailing winds could be said to come from upstream (290 Mag) and storms almost always come from downstream (110 Mag), known as the "Ronne Mank".

## **2.3 TRAVEL CONDITIONS**

Generally speaking travel on the Rutford is not difficult. The terrain is mostly flat with minor undulations around glacial "knolls". The ice stream also has a profile that varies across the ice stream as the surface rises and falls to a small degree. The vast majority of the Rutford is crevasse free, with some notable exceptions being the shear margins on each side and the "new" crevasses associated with the "knoll" downstream of the old RABID depot (2003/2004).

### **2.3.1 KNOLL CREVASSES**

There are a series of large longitudinal crevasses that stretch for many kilometers, approximately 7km from the current RABID depot – to the NE (downstream). There are probably a few dozen of these crevasses running parallel to each other. We visited the area and found one at LAT/LONG. The subtle surface depressions indicating the presence of crevasses are very hard to see from the ground, but are prominent from the air. It is quite possible we drove over a few crevasses (linked) before being able to discern one of these depressions. It took considerable digging to penetrate the roof and break in. The roof varied between 1m and 2m thick, very hard snow. A bog chisel would not penetrate the roof and we only found it with the aid of an avalanche probe.

Inside, the crevasse was up to 3m-4m wide and 40-50m deep. The ceiling was lined with an endless sheet of beautiful ice crystals stretching up and down the upper reaches of the walls and across the apex of the ceiling. It is doubtful a linked ski doo and sledge team would break through the roofs if this was typical of all the crevasses, however it would be possible to break open the roof if one was traveling parallel to the crevasses (up/down stream), directly overhead the roof).

One or two of the crevasses were visited at the end of the previous season by Ed McGough and Tim Burton. They apparently placed flags marking the holes they opened up. These flags were still visible in early 2005, but the holes well plugged.

**2.3.2 Sastrugi:** The sastrugi runs with the prevailing winds, in an upstream/downstream configuration. Most seasons it is not too large. For most of the 2004/2005 season we had very little surface roughness at all and were treated to excellent traveling conditions. Ski-doo and sledge surface penetration rarely exceeded 10cm.

### **2.3.3 Crevasses and the Shear Margins**

The Rutford Ice Stream is overwhelmingly crevasse free in its interior with one area of notable exception, the crevasses associated with the surface feature known as the "Knoll". On either flank of the Rutford's full 200km extent are heavily crevassed areas known as the shear margins. The shear margins demarcate the boundary between relatively static ice outside and the fast flowing ice of the ice stream. The shear margins are characteristically festooned with countless large crevasses in chaotic arrangements that are very difficult to cross on either ski-doo's or skis (see photos ).

### **3.0 RABID PROJECT 2004/2005**

The principal objective of the RABID project was to drill to the bottom of the Rutford Ice Stream and study the bed, where the glacier slides over the bedrock and till. Using a hot water drill system developed over many years on the Ronne Ice Shelf, various scientific instruments were to be placed at the bottom of the hole to collect data. A specialized bore hole video camera from NASA-JPL was also to be employed to visually inspect the conditions of the ice and the bed at the bottom. In addition, passive seismic sensors and GPS stations were deployed in an array on the surface to collect data complimentary to the drilling objectives. The passive seismic equipment proved troublesome and were not fully utilized. Reflection seismic techniques were used early on in the project to determine exactly where to drill, and later on the season to complete the data set initiated with the first two seismic lines.

**3.1 Daily Field Diary:** see Appendix D for a diary of daily events in the field. The field season was 95 days in length.

### **3.2 Depot Recovery**

Our first job after deployment was to begin digging up the very large depot prepared at the end of the previous season. This daunting task was made all the easier for the excellent job done by the people who prepared the depot the year before.

### **3.3 Reflection Seismics**

Reflection Seismics is the process whereby small explosions are detonated below the surface and the resultant sound waves, reflected off the bedrock are picked up by a network of geophones planted in the snow. The work consists of a series of steps, including surveying a line kilometers in length, drilling 20m holes 120m apart along the line and loading the explosive charges. On a subsequent day, the explosives are detonated with an array of 24 geophones deployed along the line. The geophones are plucked, moved and replanted for each subsequent detonation. The small hot water drill used to drill the 20m holes consists of a melt tank, burner, generator and pump. It can be mounted on a Komatik sledge or two Nansen sledges.

### **3.4 Deep Drilling Process**

A total of six holes were planned at two locations 2 km apart.

**Drill Hole #1:** The first hole drilled reached approximately 2km depth and as unexpected readings on the drill sensors were encountered the decision was made to pull the drill back up and abandon the hole. Just as this was happening a heavy snow storm with winds up to 30 knots blew in very quickly, making the work very difficult and drifting in camp. One or two hose coupling failures were experienced on the first hole.

**Drill Hole #2:** After moving the Capstan and hose reels a new hole was commenced approximately one week later. Everything proceeded relatively smoothly with the second hole. A few hose couplings failed en route to the 2km depth but these were handled without incident. However, when raising the hose for a new section to be added for drilling the final distance to the bed, a coupling failed. As the coupling was held across the top of the capstan wheel it pinched the backup prussic against the coarse grip surface on the wheel. With 2km of hose in the hole creating tremendous strain (downward force on the hose), hot water was gushing out of the ruptured coupling and the prussic was being slowly worn away as the winch continued to turn slowly against the strain. While a second backup prussic was being prepared below the capstan, in the pit, the first prussic failed. This resulted in an instantaneous and unrecoverable loss of the hose down the hole.

With 2km of the hose gone there was no way to resume drilling and with repeated coupling failures when the hose was under high tension it was also unsafe to do so. The principal objectives of the science program of RABID were no longer possible with the remaining equipment.

### 3.5 GPS LOCATIONS

The following is a list of locations of important sites from the 2004/2005 field season. The dates they were taken are shown in brackets. Locations on the Rutford Ice Stream proper will not be identical the following year: the ice stream moves at a rate of approximately 1m per day (400m/yr).

LOCATION	LATITUDE	LONGITUDE	Elevation	LOCATION DESCRIPTION	DATE Acquired
RABID DEPOT	S 78° 08.447'	W 083° 55.164'	1000 ft.	Middle of Rutford Ice Stream, north of Ellen Glacier.	FEB 14, 2005
ORIGINAL RABID DEPOT	S 78° 11.123'	W 083° 48.091	950 ft.	5.6km downstream (SE) of current Rabid Depot; 100m SW of glacio pole with black flag.	FEB 13, 2005
FLETCHER PROM GPS SITE	S 77° 53' 51.1	W 082° 35' 12.9	2300 ft.	Summit of Fletcher Promontory; approx 30km north of RABID Depot.	FEB 5, 2005
TOLLY'S HEEL GPS SITE (Flowers Hills)	S 78° 23' 43.9	W 084° 30' 15.5	4500ft.	South of Mt. Dickey, approx. 30km SW of RABID Depot.	FEB 5, 2005
RABID OVERWINTER GPS STATION	S 78° 08.438'	W 083° 54.808'	1000 ft.	Approx. 200m NNE of Depot drum marker	FEB 14, 2005
CREVASSE	<del>S 78° 23' 43.9</del> S 78 11.121	<del>W 084° 30' 15.5</del> W 083 43.486	960 ft.	1.7km NNE of Old RABID Depot	FEB 13 2005

## 4.0 DEPOTS

A large project like RABID, over 1400km south from Rothera, requires that equipment and fuel be depoted at least one year in advance. This allows for a quicker input and more logistical flexibility.

### 4.1 RABID DEPOT FEBRUARY 2005

The depot we assembled at the end of our field season is almost as big as the monster depot we dug up at the beginning of the season. While there was significantly less fuel at the end of the season, and less drill hose, there was more equipment.

Last year much of the equipment and ski-does were depoted on top of the fuel drums, most of it was all tarped. An excellent job was done (see depot diagram and photos, 2004 Appendix F). However, with only 1m annual accumulation in this part of the Rutford, we found the ski-does packed with hard snow and the entire depot drifted in to the highest point of equipment, approximately 2m above the original surface at the bottom of the drums. As a result, we decided to depot the equipment in a slightly different fashion for the 2005 winter.

We depoted most of the equipment beside the drums, rather than on top, and placed the ski-does at the end of the drum line, surrounded by empties (see depot diagram Appendix E). It is hoped that this will result in a minimum of drifting (1-1.5m high rather than 2m) and make it less likely the ski-does will be exposed to the wind for the duration of the winter. The ski-does are covered with ski-doo tarps and then a covered with a large blue tarp. Snow was piled around the edges and empty drums piled on top to help reduce the infiltration of snow under the traps and make it easier to dig them up in the spring.

The edges of the depot are marked with flags. A drum marker 3m in height was erected at the eastern end of the depot. The depot is approximately 200m towards the mountains from the overwinter GPS station and thermister string glacio-pole. Aircraft should land to the mountain side of the depot to avoid conflict with an markers and glacio-poles

**Note:** All full drums in the depot are positioned on dunnage. The majority of dunnage is oriented perpendicular to the dept line (across the icestream), to reduce chances of catching snowblower on ends (if snowblowing from one end of the depot).

no dunnage was placed under empty drums

empty drums were placed around the skidoos to make it easier to get skidoos out with a minimum of digging.

### 4.2 NOTES ON FLAGS AND GLACIO POLES

A number of flags were placed north and east of the Rabid depot in 2003/2004 for unknown reasons. They don't appear to be associated with glacio poles. It can only be assumed that they mark crevasse locations as determined in late 2003/2004 field season by E.M. and T.B. The RABID team removed all flags it placed during the field season, with the exception of the flag and poles associated directly with over-winter depot or the Wintering GPS station.

No glacio poles were installed during the RABID field season other than the pole marking the thermister string. All camp and depot markers left by the RABID team are in the form of bamboo flags or a depot drum marker. These are indicated on the area map. There are many glacio poles in the Rutford put out in previous years by other scientists, especially in the area 4-8km east (downstream) of the current RABID depot. We are not responsible for these glacio poles, nor do we have accurate positions or inventories of them. By November of 2005, these glacio poles will be either buried or protruding no more than 2m above the surface.

#### **4.3 RABID DEPOT 2003/2004**

The depot constructed at the end of 2003/2004 was excellent. All items were well tarped and laid out. We couldn't have asked for a better depot to arrive to at the beginning of the RABID field season – thanks to all those who contributed. Both Alpine III ski-doo's, depoted over the winter, started easily with plenty of battery power to spare. All 3 skidoos were packed full of snow under the doo tarps, likely an unavoidable situation given that the doos were depoted on top of the drums.

#### **4.4 AIRCRAFT RETURNING FROM 2005 INPUT FLIGHTS**

When next year's Rutherford Ice Stream field parties are input, the cargo listed below can be returned to Rothera in the empty aircraft. We had more cargo and gash than uplift flight capacity at the end of the 2004/2005 season:

- 20+ empty fuel drums (leaving 10 for a skyway markers, if req'd)
- 2 x Landfill Drums
- 6 x Large Wooden Hose Reels (Empty)
- 3 x Medium Wooden Hose Reels (Empty)
- 4 x Bundles of wood
- 1 x Compactor Bag of Gash

#### **4.5 DEPOT RAISING PRACTICES**

BAS needs to integrate standard depot practices and develop the right tools and skills for this work that occurs every season. Is depot raising planned for in the allocation of resources in a field season? Are staffing levels built to accommodate the needs? As a result of the "make-it-up-as-we-go-along" approach to depot work, more injuries and mechanical failures result. Proper tools, techniques and systems are required to do depot work efficiently.

#### **4.6 DEPOT RAISING METHODS**

Two fit and motivated people, with ski-doo's, snowblower, Komatik sledges and even a chainsaw could raise large depots of the scale of RABID within a few days, even if it was buried under meters of snow.

#### **4.7 DEPOT REPORTING PRACTICES**

Digital Photos and detailed depot notes are very helpful the following season for recovering the depot. The plan prepared by Tim Burton to accompany last year's depot was excellent. Be sure to provide both paper and electronic copies of the Depot information to FOM and the Air Unit so that the information is readily at hand the following season.

## 5.0 LIVING UNITS / STATIC CAMP OPERATIONS

This section deals with many of the details associated only with static camps. As an organization we need to be better prepared to outfit static camps from the start of the season. This will require some basic kits be assembled into a simple system that provides for all the needs of a static camp whose prime characteristic is a large number of people communally cooking and living in a large tent (WeatherHaven), and only using the pyramid tents for sleeping.

### 5.1 STATIC CAMP KITCHEN / DINING SET UP

The Large Weather Haven tent purchased second hand from the BSES (see Weather havens below) served as our kitchen / dining and main “Living” tent for most of the season. Before the weatherhavens were set up we had a traditional pyramid style existence. Instead of relying on tent boxes for an older mode of travel and field living, BAS should consider a standard set up for static camps. We have been doing large static projects for many years now. Some equipment has been obtained and developed by the scientists in charge of these projects but field operations itself has no current capacity outfitting these camps. A standard list of the basics should be assembled and contained in a couple of medium sized Zarges boxes for ease of transport and use. All the contents of a standard tent box should be included, as well as the list of items in

### 5.2 WEATHERHAVENS

We used 2 different weather haven tents for the field season, the “work tent” and the “living tent”.

**5.2.1 Living Tent (20' X 14')** This tent was purchased second hand from BSES, after it was used on Spitzbergen. It came with a heater (Tharrington Heater) that ran on avtur. It assembled easily and performed well. It was good size for accommodating the cooking and social needs of up to 8 people. It had insulation baffles in the walls and ceilings that were lined with foil, so VHF and Satellite signals could not penetrate. It also meant there were no windows. We needed as et of fluorescent lights to keep the interior lit.

Inside we had a kitchen counter, dinner table and comms tables set up with plywood on manfood or zarges boxes. The HF radio, VHF base station radio and Iridium telephone were all set up in the same corner, with aerials running out the corner of the tent. The HF solar charging system was adapted to charge everything possible running on 12VDC: Iridium telephone; VHF base station; 100Watt Radio; laptops etc. The tent is in good condition and was depoted for 2005.

**5.2.2 Work Tent (14' X 8')** The smaller of the two WeatherHavens, this tent was the focus for the science work. It had a Wabasco Heater to keep it warm, however during the mid-summer weeks, it stayed fairly warm from solar insolation alone. Plywood benches propped up on manfood and zarges boxes were set up along each wall as work spaces.

#### Stoves / Heaters

We did all the cooking for the entire time in the weather haven on one Primus stove, from the spares box. This was only possible because we had a melt tank to produce potable water, otherwise we would have needed a second stove (see “Melt Tank” below). Originally we had planned to have a Coleman 2-burner stove but it never arrived as a result of the JCR delays.

- A fireproof barrier should be installed on the wall and ceiling to protect it from stove flare ups. We didn't have any problems with the Primus, however flare ups may be more common with the petrol Coleman stoves. A fire blanket could be easily installed for this purpose.
- A fire extinguisher was on hand just outside the door of the tent. We should also have had a fire blanket handy.
- A mid-sized fuel bottle would have been very handy as the repetitive filling and re-filling of a 1L Sigg bottle were onerous. A 5L tank would be much more practical.
- The Tharrington space heater, which ran on avtur, provided excellent warmth throughout the season. It was only turned up to its maximum settings at the end of the season when temperatures were getting into the  $-20^{\circ}\text{C}$  to  $-30^{\circ}\text{C}$  range. The stove pipe and cap need to be carefully watched. When a wind switch occurs, the cap doesn't always rotate along with it, reducing the draw and resulting in the stove blowing out, pouring excess liquid avtur into the stove itself and filling the tent with fumes.
- The Tharrington heater also kept water hot in a pot on its flat top surface.
- A partial drum of avtur was suspended horizontally on glacio-poles at the back of the tent and drip-fed the Tharrington stove through a tube threaded into the small bung. This drum was refilled using either a

wobble pump an upright drum of avtur, or from jerry cans filled with avtur. On average, with the heater running for 14hrs per day, it would burn 20L of avtur in 2-3 days.

### **5.3 GENERATORS**

Small Honda petrol generators were invaluable for running various electrical appliances and chargers in camp. A 1KW genny ran most items, but a 2KW genny was necessary to run some larger appliances. The Honda E10i could be run for many hours and allowed to run dry of petrol repeatedly, day after day. The gennies were not run overnight.

### **5.4 POWER CABLES**

We had a number of power cables strung between the weatherhaven tents, running power from various generators, to various devices. The first cables were buried under the snow and this sufficed for the duration of the project. However when it came time to break camp, digging the cables out of 40+cm of compacted snow, we wished we had suspended them, which is what he had done with another line; it was suspended between 4m were thrust into the snow approx. 1m and spaced approx. 3m apart. The poles closest to the tents, at either end of the span of 20m, were tied back and anchored to support the strain. Suspending the cables in this manner would allow for easy passage of ski-doo's and sledge and no risk of damaging cables or electric shock from errant shovel users.

### **5.5 SNOW MELT TANK**

An avtur and electric melt tank was used to generate almost all our water. It was an excellent device inherited from the Ronne drilling programs. It ran on oiled avtur

## 6.0 ENVIRONMENTAL MANAGEMENT

This section covers everything from fuel handling and spills, to waste disposal and human waste issues.

### 6.1 WASTE MANAGEMENT

At the beginning of the season we used the coloured waste management bags to segregate and retrograde our waste back to Rothera: red for steel cans and blue for everything else (landfill). As the project grew in complexity and numbers of people we switched to using empty fuel drums for waste and stopped segregating cans from landfill. The impression we had was that all shredded waste at Rothera (cans, bottles and compacted card/paper etc) all ends up in landfills, so we accelerated the process by combining them in the filed.

As at Rothera, an empty fuel drum, free of fuel dregs, was drilled and nibbled to create a square opening, then positioned outside the main weatherhaven tent where most of the waste was generated. We had a second landfill drum positioned near the drill equipment to take the industrial wastes produced by the drilling.

When filled, the drums were sealed with a galvanized square steel plate, using the same self-tapping screw as on base. No mastik was used to seal the plate, as there was very little, if any, small shreds to leak out the edges (and keeping the mastic warm and pliable presented an additional problem). A cordless drill with an 8mm socket and driver was crucial to fastening the self-tapping screws.

### 6.2 FOOD WASTE

Our food waste and grey water was disposed of on site via a gash pit in the snow. Any chicken bones were disposed of as landfill.

### 6.3 TOILETS AND PEE FLAGS

A single toilet was established at each camp. At the first camp, by the old depot, we tunneled into an igloo from the previous season and dug a privy hole in its base and used a purpose-built toilet "bench" to span the gap (2' x 4' x 3/4" sanded and varnished plywood) . We put in a nice staircase leading down into it and used dunnage to mark and protect the stair edges. The door was sealed with an old box lid when weather conditions warranted.

At the second camp an igloo was built and a deeper hole excavated with a combination of manual digging and petrol melting. Later in the season we used the hot water drill to melt a larger hole a few feet in front of the original one.

There was much discussion about the merits of a pyramid outer shell as a toilet tent vs the igloo. The igloo was considered colder, but quieter and better able to withstand storms, as well as easier to enter/exit.

Pee flags were established behind every pyramid tent, the Living Tent and out near the work site and depot.

### 6.4 FUEL HANDLING

A hot water drilling project requires the handling of tens of thousands of liters of fuel hundreds of drums and jerry cans of fuel for the drill burners, pumps and gennies, the ski-doos, aircraft, stoves, snow melters and more. Each transfer of fuel from one vessel to another has the risk of spillage and almost every time something is spilled. The vast majority of these transfers are done manually.

Collectively it adds up to a lot of fuel in the snow and unrecoverable.

Individuals do take care to minimize their spills but in the end, numerous spills occur. Aardvark bollocks. We are poorly prepared to mitigate these spills in a field situation even though there are many market-ready solutions available to us: spill pads, containment drums and systems all designed to mitigate the spills when they invariably occur and/or avoid the spills in the first place.

Some simple measures:

- **Drum Funnels** should be issued to all large field parties and refueling depots. They make decanting fuel dregs relatively easy. Recovered dregs can be used in hut heaters and some engines. We had to "borrow" one from Rothera to ensure we had a drum funnel in the field.
- **Spill Containment and Storage System** can be easily purchased. They include fuel absorbent pads and a plastic drum to hold/store the soiled pads and ship them to base where they can be properly disposed of. If absorbent pads are the only item available, an empty drum opened up as for landfill but



labeled and used specifically for disposal of fuel wastes could be used.

- **Small Rubberized Spill Pads** that are then lined with absorbent pads can be used for filling up smaller items such as sigg bottles, jerry cans, generators and the like. They are folded closed (with Velcro) and stored in a convenient place (at the fuelling depot) and then pulled out and placed under the container getting refueled. The absorbent pad inside the rubberized pad soaks up any spillage and the rubberized pad stops larger volumes from flowing through into the snow until it can be absorbed. The spent pads are then discarded in the designated drum, not as landfill.

## **7.0 FIELD COMMUNICATIONS**

Field communications this season operated on three different devices: PRM HF Radio, 100 Watt HF Radio and an Iridium Satellite Telephone. The vast majority of communications with Rothera were accomplished using either the PRM or the new 100Watt set. We resorted to an Iridium call when comms were not good enough on HF or we were working away from camp and unable to return to deliver a weather ob for aircraft operations. Some difficulties were encountered with the human elements of Comms at Rothera.

### **7.1 RADIO OPERATORS**

The established comms managers at Rothera did an excellent job in all respects of field communications, from efficiently and effectively dealing with routine scheds to relaying pertinent information and getting answers to questions they themselves couldn't answer. The Army Signals radio operators, however, were a serious liability for the majority of the season. Either they are not being properly trained and briefed or they are just not up to the job.

What is known is that a tremendous amount of important stuff gets lost between the cracks for field parties, by poor execution on base.

The frustration in the field, from the Signals' ineptitude was great. Here are a few examples:

- Shopping Lists submitted verbally through Comms often were not filled or vanished and had to be re-submitted
- During drilling and drill prep we asked every day for a weather forecast and repeatedly asked that one be ready for the morning sched. Out of dozens of requests not once did Comms seem to realize we wanted a forecast every day.
- On a number of occasions we were asked to come up at a specific hour to pass weather and we were forgotten about; aircraft operations had been shut down and we were left calling an empty ops tower.
- Occasionally the missing them entirely or waiting for us to call them etc.
- Not proactive with information on aircraft or base events; we had to beat information out of them.
- Alternatives of BAS regulars, who know the field systems etc? Do away with signals people and hire inside.

### **7.2 FEEDBACK**

It is the author's understanding that a new computerized tracking system has been created to remedy these problems. It remains to be seen if this will be the panacea to a an ongoing problem. Nonetheless, more feedback to the field parties and stronger communication efforts are required to let field parties know what the big picture is, what management is thinking and whether or not the filed party requests are being actioned.

### **7.3 PRM RADIO**

The PRM radio worked well all season. It's main use came at the beginning of the season, before we got the 100Watt delivered. The PRM batteries were not charged prior to departure from Rothera, as was expected. Both batteries were last charged mid winter, resulting in arriving in the field with dead batteries. There was no spare coax cable or dipole antenna included in the radio box.

### **7.4 100 WATT Radio**

The new 100Watt radio for field use is a very good radio but it requires a large are and stable environment to be set up in (WeatherHaven or Hut). It is not weather proof or condensation proof like the PRMs.

The extra power and large aerial mean more reliable HF comms. The system is well configured by Comms and includes plenty of solar power and battery reserve. The solar charging system can also be used for DC charging of other devices such as the iridium telephone, VHF radios and laptops (assuming you have the right connectors for all of the above).

We would recommend a third glacio pole to support the middle of the aerial, otherwise the aerial will sag dramatically and suffer in heavy winds. We cable tied one of the middle insulators to a middle glacio pole and this did a much better job of supporting the aerial than the two pole system recommended by Comms.

### **7.5 VHF RADIOS / BASE STATION RADIO**

We used marine-band VHF radios for safety communications when traveling on the ice stream away from

camp. A VHF base station radio, with high gain whip antenna and more watts than the hand-helds was installed in the weather haven tent to communicate with the mobile units and act as a listening point for any distress calls from the traveling parties. This unit, which does not have its own battery, was powered through the 100Watt radio battery and solar panels.

### **7.6 FRS RADIOS / PUBLIC BAND**

Four “FRS”radios were used on the RABID project for communications over short distances during surveying, drilling, GPR and between tents in storms. They were cheap and effective and I would recommend them highly. Their range didn’t extend far beyond 1.5km.

### **7.7 AERO-VHF RADIO**

This was a very handy radio to have given the number of flights to and from RABID. Every field party, especially static ones, getting a large number of flights in a season should be issued with one. Communicating with the aircraft on VHF (118.1) allowed us to relay the latest skiway weather and discuss the aircrafts final intentions (regarding fuel and cargo etc). This model (old yellow variety) is very sturdy and reliable. It recharges with a small adaptor cord through the PRM solar panel.

### **7.8 IRIDIUM SATELLITE TELEPHONES**

The remote antenna provided with Iridium (from Motorola) has a coax cable only 2m long, not long enough for positioning the aerial outside a weather haven or pyramid tent.

The Iridium works well inside a pyramid tent, however the signal is impeded inside an insulated weather haven tent, with foil lining the insulation.

Rothera Comms made us up a 5m coax extension aerial with the appropriate connectors at each end to lengthen the reach of the remote antenna. It took repeated requests for this extension coax to be made, as Comms were under the impression that the cable needed some special configuration rather than just a straight coax. However, as we expected, a straight coax does work perfectly, without any problems, as was demonstrated with over 2 months of use in the field. Motorola is probably trying to make a fast buck selling their “special” cables at special prices.

A small laminated cue card accompanying each phone would be very helpful, with emergency and comms contact numbers and how to dial them. While all this information is provided in the manual and largely present with the BAS phone list drafted by comms, these sources are neither comprehensive nor handy (A4 etc). The basic info on how to dial, how to use the autodial, what the autodial numbers are etc, should be provided in a pocket-sized format for ease of use in the field, especially when not carrying a sheave of folders, on foot etc.

- Useful for field travel (emergencies) when PRM would be cumbersome and slow to set up. Able to do wx scheds while working away from HF set.
- A single emergency number should be established so that there is a single point of contact at Rothera. There should always be at least one person that can be contacted day or night from the field. A simple pager system would not be difficult to install or operate and carried by the designated duty officer or manager on call. Having contact with someone in Cambridge doesn’t necessarily do anyone in the field any good as they will not have all the relevant info at hand to deal with an emergency.

## 8.0 TRAVEL UNITS

The technical traveling we did during the field season was all in the middle of the Rutford Ice Stream. It was half unit, linked travel of a preventative nature, doing recces of areas to ensure they were safe for unlinked travel. Some GPS navigation was done. No difficulties were encountered.

### 8.1 SKI-DOOS

For the RABID project we had 2 Alpine III Ski-Doos and 1 Alpine I. All three ski-dooes were depoted over winter the season before our arrival. All 3 started easily. The Alpine IIIs even had enough battery power to crank over and start after we dug them out of the snow – very impressive. We used all 3 machines regularly, with the Alpine I getting the least use. The Alpine I rarely left camp and was used mostly for hauling drums and cargo around camp. The Alpine I also did its share of depot raising, especially early in the season. We purposefully tried to concentrate the drum raising efforts to the Alpine I, to spare wear and tear on the IIIs, however when we started to move the depoted drums from RABID to Drill Site #1, the Alpine IIIs were used to haul Komatik Sledges with 4 drums each. The Alpine IIIs had superior pulling power and traction up the ramp (out of the depot hole) for this.

There is absolutely no doubt in the RABID team that Alpine IIIs are the way forward. They performed splendidly, with little or no maintenance required. They turn easier, handle better, are far more comfortable and easier on the driver than either the Alp I or Alp II.

- The modifications BAS has done to the Alpine IIIs for the towing capability and aircraft loading are excellent and used seamlessly in the field. However, with heavy towing and long distances traveled with heavy loads, cracks start to appear in the metal frames at the welds, where the cargo cage meets the main frame.

### 8.2 SKI-DOO NOTES FOR 2005/2006 FIELD SEASON

- Pre Deployment Checks: The 2 Alpine III ski-dooes flown down in February 2005, to be depoted over the winter for next year's field season (2005/2006) were in worse condition than the ones we had been using all summer and had put over 2000km on. The "new" ones had flat batteries, no GPS mounts or any other of the expected accoutrements. It is likely they were shipped down after being stored in the Miracle Span at Rothera, without being tested, cleaned or prepared for deployment. This shouldn't happen.
- We took the time to change the batteries, swapping the better batteries from our Alpine III's in to the wintering doos. We also swapped the GPS mount on the steering column from an outgoing Doo to a wintering Doo.
- The following will be required next year for these doos to be complete for a full travel season (in addition to usual stock of link lines etc etc):
  - 1 x GPS Mount base plate
  - 2 x GPS mounts (everything beyond the base plates)
  - 2 x Maillon Spanner (21mm?) (1 RABID spanner was left with one of the doos)
  - 2 x U-Bolt Shackles
  - 4 x Maillons for Linked Travel (min)

### 8.3 SKI-DOO NUMBERS FOR SLEDGE JULIET

SKI DOO	ODOMETER At start	ODOMETER At end	Total kms Traveled 2004/2005	Comments
Alpine III (A) S/N: 3-19/110462/2002	553 km	2234 km	1681 km	Ran very well all season.
Alpine III (B) S/N: 3-24/112512/2002	599 km	2315 km	1716 km	Ran very well all season.
Alpine I	Odometer Not working	N/A	400+ (estimate)	This unit was in rough condition but still provided many valuable work hours
Alpine III (C) S/N: 3-10/108780/2001	2140 km	2360 km	220 km	2005 Overwintering Ski-Doo. Better Battery swapped in before depoting

Alpine III (D) S/N: 3-20/112004/2002	1510 km	1685 km	175 km	2005 Overwintering Ski- Doo./ . Better Battery swapped in before depoting.
TOTAL DISTANCE traveled by SKI-DOO			4192 KM	

#### 8.4 GPS Mounts

Only one of our Alpine IIIs came with a GPS mount. The mount was located up on the horizontal aspect of the dash board, left side, fixed to the yellow plastic cowling. Actually navigating with a GPS 76 mounted in this position was difficult because it was so hard to see the GPS screen, especially when it would be vibrating with the movements of the ski doo. I added a GPS mount on the steering column of the second Alpine III, to the rubber cover between the handlebar grips. It proved much easier to see and use. It is easier to push the buttons, change screens and use the GPS unit properly in this position without having to stop the ski doo. The threaded pin that holds the mount to the structure screwed into the skidoo, can vibrate out and result in the plastic holder for the GPS and the threaded screw disappearing, especially when the GPS unit was not mounted in place.

#### 8.5 SLEDGES

We had a variety of sledges for the project, including 2 nansens, 2 Komatiks, 2 Siglins and one small orange utility sledge.

**8.5.1 Siglin Sledges (plastic)** The Siglin sledges are an excellent, multi-purpose tool for static camps. They have very low drag friction, are very stable, good for moving all kinds of equipment and supplies, around camp or when traveling. They are very easy to load given the low, flexible sides.

- Good lashing system, simply requires some extra rope, perhaps some karabiners
- Spare bolts and towing tongues are useful. More spares should be stocked.
- Weak points may be the towing tongue, but that is not to suggest it is weak.

#### 8.5.2 Nansen Sledges

Used very little, they have their place but are not a very useful tool. We would have been better off with additional Komatiks. Useful when 1/2 unit travel and linked travel are required – that is their forte – what they have been developed for.

-very little wear and tear.

#### 8.5.3 Komatik Sledges

These sledges, designed by Andy Smith after seeing them on a season with USAP/NSF, are a modification of the traditional Greenlandic sledge (see photos Appendix G: Komatik Sledges). Commonly used in the arctic, and originally developed by the Inuit they have been adapted more recently with modern materials. These sledges are the way forward for work on ice shelves and ice streams where flat ground is the norm. It is hard to over-emphasize how much better than the Nansens these sledges are, for so many applications. A testament to their durability and utility is how many miles and fuel drums and tones of cargo we moved and handled on Komatik sledges with almost no maintenance, no hassles, and an ease of use unknown with Nansens.

- **Stability:** Because they are low and wide, a Komatik sledge is very stable. Consequently, unlike a Nansen, it can be loaded quite high without exceeding its center of gravity, even when traveling in soft snow conditions it is unlikely to tip.
- **Drifting:** Anyone who has parked a Nansen sledge and then tried to dig it out after a storm will know how Nansens are magnets for drift. All the rope rigging and stuff dangling down results in heavy drifting and maximum hassle when digging them up - and risk of damaging the sledge with a shovel as you do so. Komatiks are the exact opposite. They will remain virtually drift free in moderate blows as the wind whistles through, between the runners and below the decking, leaving little or no drifting behind. We even used the Komatiks as storage platforms to keep other sledges and equipment from drifting in when storms hit.
- **Lashings Systems:** The sledges didn't come manufactured with lashing systems. The lash lines rigged to the sledges are very simple and could probably be improved by a sledge-savvy GA. The lash lines

rigged for the 2 Komatiks were made mainly as anchors for cargo straps. We used cargo straps for securing drums and cargo to the Komatiks, almost exclusively.

- **Capacity:** One Komatik sledge will easily take 4 full drums of fuel, lying on their side and secured with a single cargo strap down the middle (see Appendix G: Komatik Sledge). It is possible to haul double sledges with 4 drums each on good flat surfaces but doos challenged and not recommended for wear and tear on the ski-doo – an indication of the power and performance of the sledges and Alpine 3's.
- **Towing Systems:** The Komatiks are currently rigged with 20mm rope tow lines that anchor to both runners. When one of these sledges was first trailed at Halley, they had a rigid bar towing system. That system was not trailed by this author but may be quite useful. The sledges do have a habit of sliding into the back of the skidoo when you stop. The tow ropes are not very long.
- **Aircraft Loading:** The sledges are excellent for loading and unloading aircraft in the field. They can take a large volume of disparate items and moved to/from the plane as required. When loading the sledges themselves into the Twin Otters, the sledge must be raised on its edge, slid into the fuselage and then lowered to lie flat on the floor, after which cargo can also be placed underneath the sledge. Note that it is very difficult to combine both a Komatik sledge and Ski-doo in the same load. They need to go on separate flights. A Komatik sledge weighs approximately 220 lbs without a rigid trace.
- **Plywood Decking:** I made up some plywood decking for each of the two Komatiks. The impetus was to both protect the slats from repeated heavy abuse (moving 100's of fuel drums etc) and also make them easier to work with a flat, strong surface. The plywood decking minimizes sledge damage by taking heavy blows and distributing heavy weights evenly. They also make cargo handling, drum handling etc much easier – things can be slid on/off and positioned much easier than if only the slats are present.
- **Limitations:** Because the Komatik sledges have no keels or breaks they are limited in their uses on side slopes and hills. Crude rope breaks at the front of the runners have been used with moderate success, for taking a Komatik downhill.

It would be interesting to know how much a Komatik costs when compared with a Nansen. I would recommend one or two be purchased annually for the next few years. I predict that these sledges will grow in popularity and a wider variety of uses will appear and custom modifications will be made to make them even more useful.

On base they could be used for transporting more cargo where a snowcat might be required, but inconvenient. Box sides that are removable might be a good idea. They would be especially useful at Halley.

## 9.0 CLOTHING AND EQUIPMENT

Contained in this section are some comments and suggestions of important items used during the field season. A summary table can be found in the appendix.

### 9.1 Depot Raising / Drum Handling Equipment

#### Drum Chains

Drum chains are an essential tool for towing full fuel drums out of depots and into position on the surface. Most sets of drum chains can be augmented with a short length of 20mm rope (2m) with eyes spliced in both ends. The extra length allows for greater maneuverability and a safer distance between the ski-doo and the drum. Extra bulk bungee cord is always handy if the old bungee gets too tight, breaks or needs replacing.

#### Drum Levers

Drum levers, for lifting fuel drums upright onto their ends with minimum effort, are another essential tool for depot work. Drum levers can save a lot of effort and avoid manual handling injuries with drums. They are also very handy for breaking drums out of hard snow and iced-in conditions. Four more drum levers were requested for manufacture over the winter at Rothera as the supply appears to be meager.

#### Drum Spanners

The drum wrenches or spanners recently purchased (that are brass plated and have very conceivable drum lid configuration) are not practical. They do not have a tab for removing the seal and they are awkward to use. The basic drum spanner as used by the air unit is best – and probably cheaper too.

#### Chainsaw

A small Stihl chainsaw was purchased for this project to aid in the excavation of drill pits and ice core storage areas. It was very useful in dense snow. All safety equipment was provided. The chainsaw would also be very useful in dense snow when excavating a depot buried for a number of years. Quick passes with a chainsaw and then breaking the blocks out with a shovel for the snowblower is fast and efficient.

- The 16" bar originally was considered too short for efficient use on our project (would have liked a 22" or 24" bar) but the short bar still proved effective, and in some cases (igloo construction) desirable.
- Chain oil is consumed at less than 20:1 ratio in cold weather because of the high viscosity of typical chain oil – simply leaving the chain oil setting at the factory level results in very little chain oil being used.
- 50:1 fuel mix was used, utilizing the manufacturers 2-stroke oil. Do not use regular 2-stroke oil as provided for ski-doods etc.
- proper training and experience is recommended before anyone uses a chainsaw.

### 9.2 HONDA SNOWBLOWER

The Honda snowblower we had at the beginning of the season was excellent for depot work and camp snow management. I would recommend we get more of these machines. They should become the new standard for depot raising work to both make depot raising easier and less hazardous for the people doing it – it will reduce manual handling and repetitive strain injuries if used properly.

#### 9.2.1 Limitations

The Honda snowblower has its limitations. It will not cut through hard packed snow all on its own. However if used properly it can dramatically reduce the effort required to excavate large volumes of drift and hard pack. In a two person operation one can be manually cutting and breaking up the snow into chunks with a shovel while the snowblower operator then gobbles up the snow with the Honda and sends it flying out of the hole etc. The vast majority of strain and labour intensity in depot work comes from throwing the snow out of the hole. This machine mechanizes and therefore minimizes that stage of the work.

#### 9.2.2 Shear Bolts

When one operates the snowblower so that it hits dunnage, rope, drums or anything hard, the shear bolts

will shear and the rotors will stop, thereby saving the drive train from any damage. As a result the operator has to be careful to avoid these hazards. He/she must also have a ready supply of the proper shear bolts on hand. Shear bolt replacements are quick and easy.

A large quantity of shear bolts should be ordered from the manufacturer and kept in stock (in the 100's). Digging into a depot, even with a cautious operator can result in a few dozen bolts being sheared in a few days.

The ski-doo can ice up underneath and in the front hopper. The rubber stick that comes with the blower can be used to chip the ice out. Tarping the blower up with a black tarp will also result in the melting out of accumulated ice, under most conditions.

Beware of the assembly bolts rattling loose in all locations as a result of regular loose. Repeated checks of all visible bolts should be done daily. Spare bolts should be supplied by the mechs and kept with the blower tool kit.

### **9.3 Pyramid Tents**

We had a total of 5 pyramid tents on the RABID project, including one generator tent (outer only) and one 3-person tent. They all preformed well throughout the season. Each tent got a different length of use. The generator tent was only used for a few hours during one day for repairing a hot water drill burner. It was depoted. The 3-person tent was appreciated a by a number of people, primarily in a 2-person configuration. If given the choice I would prefer the roominess of a 3-person tent (for 2 people) than a regular 2-person unit.

### **9.4 Working With Cable and Hose Reels**

Lazy Susan: use a heavy duty turntable rig to spool out reels of cable and hose in a horizontal position; could be a good option when heavy reels are to be unfurled. Lee Valley/Canada sell a turntable assembly that can be built up to custom specs, and will hold/turn up to 1000 lbs.

## **10.0 AIR OPERATIONS**

We received over 40 plane visits in the season. All the aircraft operations went well, however there are some ways we can improve.

### **10.1 AIRCRAFT SAFETY /Emergency RESPONSE**

We had a very high number of aircraft visits for a field party, approaching the kind of volume expected at the regular fuelling depots like Fossil Bluff and Sky Blu, however many of the standard safety practices and equipment used at the regular depots are ignored at these large static camps. There is a paucity of SOPs as well as training and equipment.

- Establish small SOP manual for aircraft operations at field camps receiving large number of aircraft visits.
- Fire sledge set up, on a simple small plastic sledge: fire extinguisher, fire axe, fire blanket etc.
- Advanced first aid kit designed for trauma and accidents, not a field medical box (See Health and Safety Section, below).
- Aero-VHF radio handy
- Appropriate training

### **10.2 AIRCRAFT RAMPS and SLIDING BOARDS**

The aircraft ramps depoted the winter before were not very good. One was twisted and made of a lighter metal. When fuel drums were rolled down the ramps, the twisted ramp would have a tendency to pop out of its hole in the fuselage. We sent both ramps back to base in exchange for some good ones.

More and more projects are using heavier and heavier pieces of equipment, requiring inventive manual handling in the field to get these behemoth generators and drilling rigs in and out of twin otters. The big pieces of kit, some weighing in excess of 300kg, are loaded at Rothera with a forklift. There are no such luxuries in the field. To cope with this inevitability of handling these big heavy units, especially for re-loading during uplift at the end of the season, we needed a system. We came up with some "sliding boards" that proved a much greater success than first envisioned. Consisting of two pieces of 3/4" thick coated plywood (dark brown/slippery surface) cut and modified to fit on the aircraft loading ramps, the boards proved useful for all types of cargo handling, both unloading and loading:

- Heavy machines
- Zarges boxes
- Sledge Boxes
- Awkwardly shaped equipment etc



Any item short of a ski-doo or a fuel drum could be slid up/down the ramps to/from a Komatik sledge waiting at the end of the boards. A pilot unloading his plane of countless boxes could just slide each item down the ramp and it would be immediately placed on the sledge, over 2m away from the aircraft, minimizing the tedious and repetitive the lifting, twisting and multiple handling.

The sliding boards bear the vast majority of the weight of the cargo and cargo slides easily up/down its surface, making loading and unloading heavy items relatively easy. It would have been next to impossible without these boards.

We secured the boards in place over top the aircraft ramps with two 1m glacio-poles, looped through web strap handles made as part of the board. This stopped the boards from moving up/down the aircraft ramps under the weight of the cargo.

## **11.0 HEALTH AND SAFETY**

Health and safety in the field is practiced with a common sense approach, rather than the over-regulated, officious environment one can see around work activities on base. Some aspects of static camps make them a lot more like industrial work sites than traditional field camps. While the over-the-top approach to safety might not be welcome, there are places where we can make substantial improvements to the existing systems.

There were no lost time injuries during the field season. One minor injury requiring medical attention was a broken thumb, incurred when a heavy part of the drill winch fell on the person's thumb during assembly.

### **11.1 Medical Boxes vs Grab Bags**

The field medical box, contained in a sledge box, is an outdated concept for large static camps. It is designed for two people in a traveling team, not for 6 or 8 people in an industrial site. It is too heavy and too densely packed for efficient responses to accidents and incidents. While the field medical box still has all the necessary items for care in the field perhaps a second trauma-oriented set up should be considered for large static camps. This equipment could also be used at a busy skyway.

Contents: oriented towards trauma and rapid response rather than long term care; A full set of vacuum splints, additional burns treatments/dressings; folding stretcher or scoop etc.

Packaging: instead of being an awkward and heavy box have a grab-bag setup like on base for accident response.

## 12.0 GA PLANNING FOR A LARGE STATIC PROJECT

To date, the principal scientists involved in a large static science project have done most of the planning and preparation for the field season and the FGA, coming late to the scene, is thrown in at the deep end. Problems may arise with the fact that the scientist has planned for all the scientific equipment and many of the field kit however, frequently lots of gaps remain. The rush to get into the field results in lost opportunities to complete those details. As a result, one arrives in the field and spends the first few weeks realizing what has been forgotten.

To a certain extent this will always happen – sometimes it is nearly impossible to predict many of the small details of what is needed, until you encounter them in the field – especially for new GA's.

Wintering GA's have the luxury of being on base and having project details well in advance of their deployment and can whittle away on them, dream up new ones etc and be far ahead of the game by the time the field season starts.

Perhaps an addendum to the field operations manual can be written about typical large static camp setups.

## 13.0 GPS BASE STATIONS

Two GPS Base stations were set up on each flank of the Rutford Ice Stream, to the north and south. Both the Fletcher promontory and the Flowers Hills were accessed by Twin Otter.

### 13.1 TOLLY'S HEEL GPS BASE STATION (FLOWERS HILLS/ELLSWORTH

**MOUNTAINS)** S 78° 23' 43.9 W 084° 30' 15.5 After a minimum of searching from the air we were able to find a very accessible outcrop of rock upon which to establish a GPS base station for the bulk of the field season. We named it Tolly's Heel in honour of Gudfinna Adalgeirsdotter, one of our team members who never made it south of Stanley on account of a dancing injury sustained in the heat of the battle waiting for a Dash flight to Rothera. This small nunatak sits in a glacial basin a few kilometers to the SE of Dickie Peak in the Flowers Hills, just east of the Hansen Glacier, north of Mt Vinson. Approach from the air through a broad pass between peaks at lat/long and lat/long (see map and photos in Appendix C). The area near the nunatak is what appears to be a crevasse-free basin, allowing aircraft to land and taxi to within 100m of the rock, unimpeded. We left a line of bamboos and one flag marking a trail from the wingtip of a parked Twin Otter, to the NW corner of the nunatak. Access from the plane to the rock takes less than 5 minutes.

The GPS location was marked with a rock cairn over top of a small "X" chiseled into the rock. Since the rock was quite friable it was decided not to hammer in a brass survey marker. This **can be done properly with a drill and cement etc on a subsequent visit.**

**13.2 FLETCHER PROMONTORY** S 77° 53' 51.1 W 082° 35' 12.9 Access to the Fletcher promontory is easy. A Twin Otter could land nearly anywhere on the summit plateau. We landed and set up the GPS right off the wingtip, without need for roping up or taking any other precautions.

#### 14.0 MAPS AND SATELLITE IMAGES

The old USGS (Antarctic Reconnaissance Series) maps are the best topographic maps of the area and are in short supply. It is believed they are out of print. BAS's MAGIC division has made some excellent composite images from Landsat7 data. A series was made of the entire Ellsworth/Sentinels areas in the search for a possible blue ice depot area.

MAP REFERENCE NUMBER	SCALE	AREA NAME
USGS - S7800-w8200/1x6	1: 250,000	Vinson Massif, Antarctica

#### REFERENCE PHOTOGRAPHS

A companion CD full of photographs is submitted with this report. It includes hand held aerial photos of the Rutford Ice Stream, Flowers Hills and surrounding areas as well as detailed photos that illustrate some of the ideas presented in the text.

---

**APPENDICES A & B (MAPS) FOLLOW ON THE NEXT TWO PAGES**

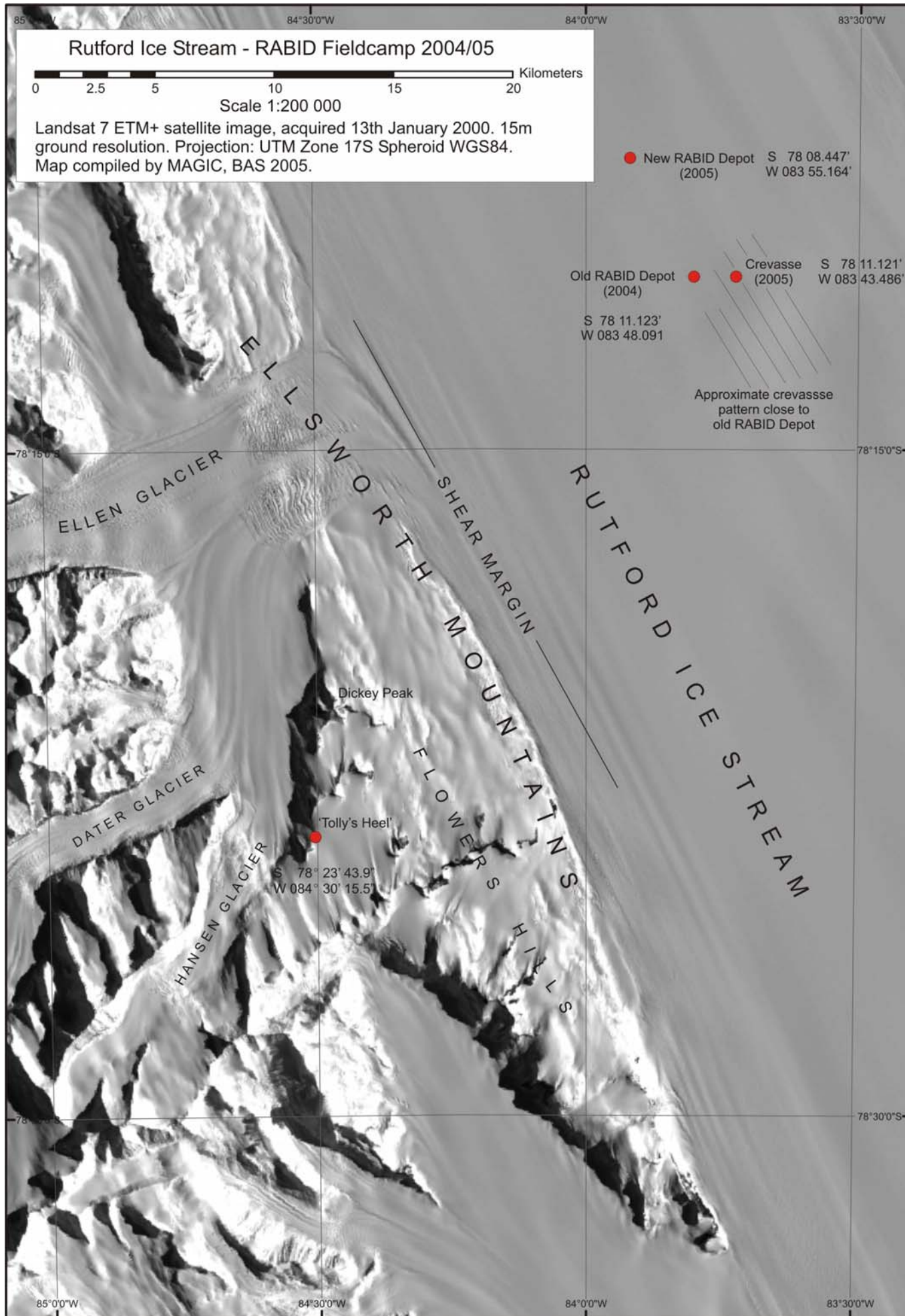

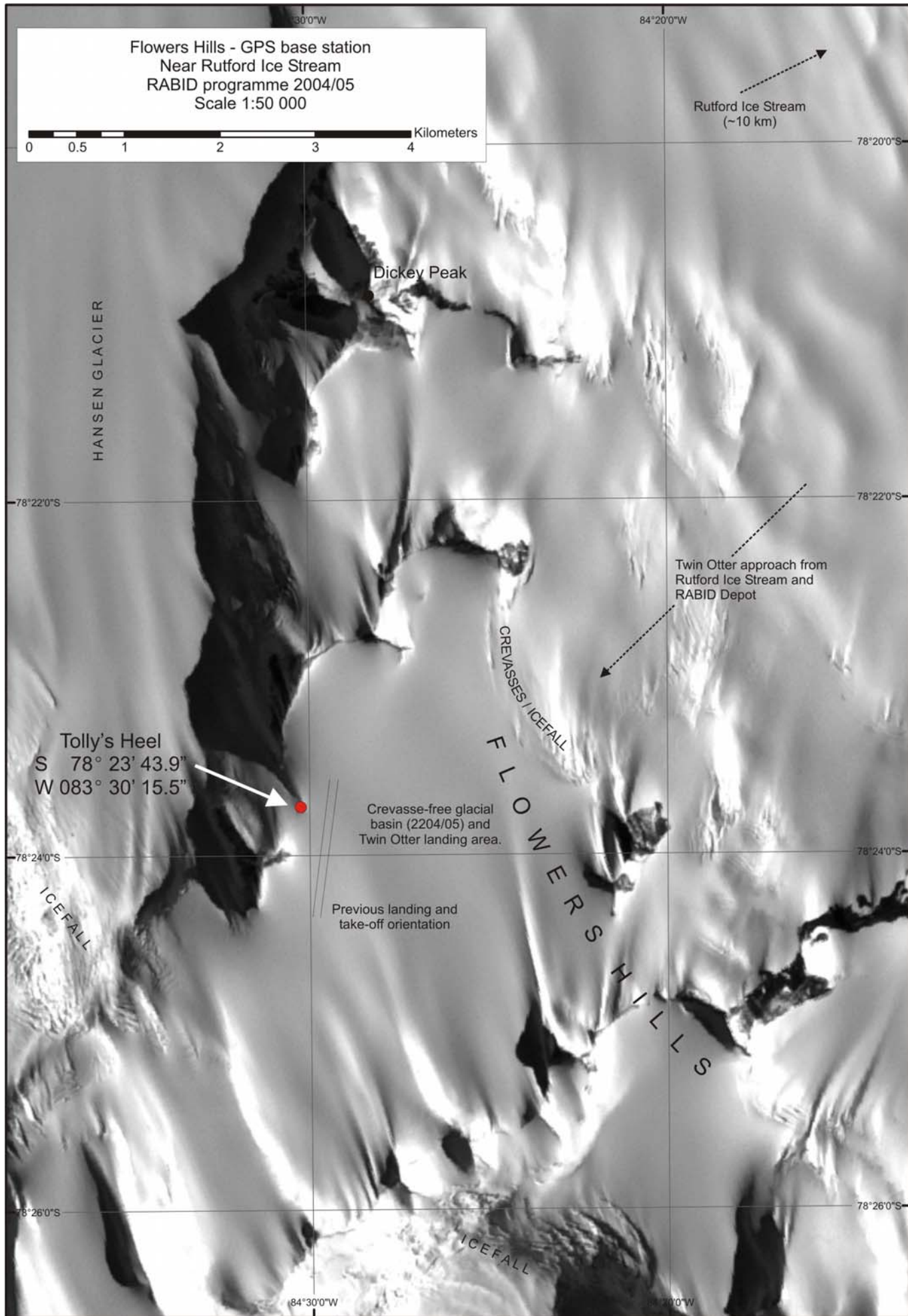

**APPENDIX C – DAILY DIARY**

RABID / RUTFORD ICE STREAM DEPOT 2004/2005		
DATE	DAY	COMMENTS / ACTIONS
18-Nov	1	Input Flights from Rothera for Smith and Taylor - 2 aircraft: BC & BL overnight. Ski-doods dug out of depot.
19-Nov	2	Area recce with linked half unit travel. Placed flag on first seismic line site start (Tyree Line). Drums raised from depot and science kit prepared.
20-Nov	3	Toilet Igloo gup and perpared. More work on raising drums and preping science kit for reflection seismics.
21-Nov	4	Moved one Komatik load of drums to New depot location 6km upstream. Used big GPS to ascertain exact positioin for start if Tyree Seismic line. Surveyed 3.6km line.
22-Nov	5	LIE UP due to poor weather
23-Nov	6	Seismic drill assembled. More depot digging and recovery of drums and equipment to the surface.
24-Nov	7	Hot Water Drill for Sesismics assembled and H2O prepped. AZ brought in load of science cargo from Rothera, include snowblower.
25-Nov	8	Depot raising work and more seismic drill troubleshooting. AZ brought down science cargo, delivered to Drill site.
26-Nov	9	Drilling of seismic holes x 22+. AZ delivered more science cargo.
27-Nov	10	AZ delivered another cargo load from Sky Blu. HF aerial on plane broken upon arrival. Remainaing 14+ seismic holes drilled.
28-Nov	11	Moved 4 Avtur to Drill Site 1 Depot. 1/3 of seismic line completed/data collected.
29-Nov	12	Keith N and Tavi Arrive at Rabid in AZ. BC delivers two loads of Avtur to Drill Site Depot
30-Nov	13	Seismic Line completed by AS and TM. 4 avtur moved to Drill Site Depot. BC delivered 4 drums avtur to Drill Site as did AZ. Recce flight for Blue ice on west end of sentinels, in evening. 2 x otters overnight.
01-Dec	14	Depot Work. Seismic data processed
02-Dec	15	Alex Cottle arrived in AZ, and BC, with science cargo, all delivered to Drill Site. Mogenson seismic line surveyed. GPS stations prepared by TM. BC overnight.
03-Dec	16	4 drums raised and moved to Drill Site depot. BC departed for PNE with fuel and empties. BC returned from Pine Island. 15 holes drilled on new seismic line.
04-Dec	17	LIE UP
05-Dec	18	LIE UP. Iridium data connection set up by KN
06-Dec	19	Remainder of seismic holes for Mogenson Line drilled. 100Watt radio set up at Drill Site with VE25. Depot raising work.
07-Dec	20	BC and BL to RABID en route to PNE. BL olvernight at RABID.
08-Dec	21	BL to PNE. Took 5 drums in tank. Depot raising work. Moved drill equipment to Drill Site. Beaker conference to determine site of first drill hole. BC arrived en route to PNE. Took 3 drums of avtur.
09-Dec	22	Igloo Dug at new camp site. Weather Havens set up at new site. Andy drilled remaining seismic holes.
10-Dec	23	Moved camp from RABID depot to Drill Site #1. AZ delivered 1/2 cargo load plus 3 avtur. AZ overnight.
11-Dec	24	Wx Haven tents set up continued. Depot work and igloo work completed.
12-Dec	25	19 DRUMS MOVED TO DRILL SITE DEPOT, INCLUDE 4 PETROL
13-Dec	26	24 avtur moved to drill site 1. Drill equipment moved also. Big drill set up started by KM. GPS and passive seismic equipment prepped by TM and AS.

14-Dec	27	Moved avtur to drill site depot.
15-Dec	28	Drill assembly by KN and AC. Depot maintenance at drill site by AT. Drill equipment hauled from RABID to drill site depot.
16-Dec	29	Half unit travel with AS and At to recce seismic and GPS array locations distant from camp. All OK. Drill assembly continues by KN and AC.
17-Dec	30	GPS array established by AS and TM. Drill assembly continued by AC and KN. ONE PETROL DRUM DECANTED INTO JERRY CANS, skidoos etc.
18-Dec	31	4 Komatik loads of Avtur from Rabiud Depot to Drill Site #1. Starting to use avtur to melt water for first flubber. Drill assembly continues. Avtur moved to drill site from RABID depot.
19-Dec	32	Drill prep and depot maintenance.
20-Dec	33	Drill prep and depot maintenance.
21-Dec	34	Drill prep and depot maintenance. GPS and seismic array maintenance by AS and TM.
22-Dec	35	AZ arrived with cargo, Doc Jo to tend to AC's thumb and KM arrives. 5 AVTUR MOVED TO 2nd row of BURNERS as they were fired up. Cargo runs from RABID depot
23-Dec	36	AZ with cargo. Drill prep and depot maintenance.
24-Dec	37	Full day of raising and moving drums of Avtur from the Rabid Depot to the drill Site #2, with both AlpIII's and 2 Komatik sledges
25-Dec	38	2 loads moved, and depot marker raised. BB in with Cargo and GPS flights attempted.
26-Dec	39	15 Loads raised and driven upstream in marginal conditions to Drill Site #2. Objective was to clear depot of fuel drums before storm set in.
27-Dec	40	LIE UP
28-Dec	41	Drill prep and depot maintenance. GPS and seismic array maintenance by AS and TM.
29-Dec	42	Moved 6 Orange Hose reels from Rabid Depot to Drill Site #1
30-Dec	43	Moved last of Orange hose reels to Drill Site #1 and one of black reels to Drill Site 2 . Alberto Behar Arrived in AZ and deployed Tumbleweed for first test. Flew to feltcher and Flowers Hills to do GPS deployments. Geoff Porter pilot. AZ overnight.
31-Dec	44	AZ deprated at 0930L, after taking 1.5 Avtur and deploying Tumbleweed, test #2. Inventory of Drums taken, partials sorted etc.
01-Jan	45	Moved remaining reels of hose etc from Rabid depot to Drill Site #2; good wx.
02-Jan	46	BB Visit with no cargo, took away snowblower for depot work; battery box (vermiculite) and Keith Nichols. Andy Lole co-pilot. Took 1 Drum Avtur
03-Jan	47	1 Landfill Drum sealed (Wx Haven). 2 More made from empties pile. AB worked on camera; TM and AS worked on instr strings and seismic instr.
04-Jan	48	Drill charged up and black flubber filled. Short hole bored; nozzle tested above ground.
05-Jan	49	Drill Equipment preparation and drill tutorial.
06-Jan	50	More drill equipment preparation. Refuelling/topping up of drill burners. Laying out of Instr String for first hole. Dingle weather.
07-Jan	51	Another Dingle Day, as Fraser forecast. Another day of drill prep with drill day moved back to Jan 8. 4 Avtur moved from aircraft depot to drill burners, in prep for 8th. 5 Empties readied for PNE. Empties in skiway are 4 petrol, 2 markers, 1 ANI, 1 Landfill. tea urn hooked up.
08-Jan	52	First Day of drilling; around the clock work, little sleep.
09-Jan	53	Second Day of Drilling. BB flew back through RABID to Rothera after departing PNE and took our electric motor for hyddraulic unit, after much debate as to whether or not it should go out. They left all kinds of US food.
10-Jan	54	Third Day of Drilling. Reached 1.9km depth but forced to retreat when problems encountered with drill and big, unexpected storm hit.
11-Jan	55	Rest Day
12-Jan	56	Digging out after the storm; overcast, poor weather with moderate winds; temps in the high single digits (-8C etc).

13-Jan	57	Started Drill Pit #2. General Drill Prep. BB arrived late in evening en route to PNE (Doug and Kelly). John Withers dropped off.
14-Jan	58	General Drill prep. Finished Drill Pit. Tested Nasa Cam in old hole. Nice start to day, but overcast for most of it.
15-Jan	59	Preparation for Drill Hole #2: Wx warm, calm but overcast and poor contrast. Hoses on reels, string prep, new loo hole with H2O.
16-Jan	60	Drilling started for Hole #2. All drums topped up. Drum numbers indicate totals at start of drilling, include. Drums dropped off by BB. BB delivered Avtur and goodies
17-Jan	61	Drilling Continues through the day and night
18-Jan	62	Drilling continues and then disaster strikes with hose lost down the hole. BB Arrives with Doug and Phil. Take empties to PNE. Return and take Alberto to Rothera. BL arrives in evening after doing survey work. Stays O/N.
19-Jan	63	Fuelled BB with 4 Drums in AM for local Survey work. Beakers talked about new plan for season and prepped radar. General Camp cleanup. BL stayed O/N w/hot tub etc
20-Jan	64	BL took more fuel and departed early pm for Berkner Survey. Camp and work areas cleanup for the day.
21-Jan	65	Slow Day. Drilling decision made = no more deep work. Moved 24 drums from site 2 to new site/problems with loose snow. Aircraft expected dset PNE. Poss O/N Rabid. Ends up not coming.
22-Jan	66	Nice Wx. Tavi and Keith did GPR, Andy crunched data. Slow day for labourers.
23-Jan	67	Nice wx, dingle with no wind until afternoon. BB with Alan and Rod passed through en route to PNE. Fuelled with 3 Drums. Dug vault for cores and moved capstan, fuel drums etc.
24-Jan	68	Ice Core drilling to 90m depth. 12m of core taken and stored.
25-Jan	69	Drill equipment take down and prep for uplift flights commences.
26-Jan	70	Surveying for new seismic lines. Drill take down commencing.
27-Jan	71	Depot Work / Drill disassembly
28-Jan	72	Seismic drilling and loading all Day
29-Jan	73	Seismic drilling and loading all Day
30-Jan	74	Seismic drilling and loading all Day. BB (Ian and Bernard) dropped off first AlpIII (2114) and 2 Avtur, took Load #3 Uplift.
31-Jan	75	Dismantled Winch and did more depot work, depoting engines and burners etc, while GPR and seismic prep done.
01-Feb	76	Rolled up remaining hoses and hauled all drums from site 2, while GPR done on 1 2/3 lines and GPS profiles completed
02-Feb	77	Ground Pen Radar work accomplished. BB arrived with 2nd AlpIII (?km) GPS Power Unit and 2 Avtur Drums. BB Overnighted at RABID
03-Feb	78	GPR work accomplished. GPS Base Station retrieval flights to Fletcher Summit and Tolly's Heel successful on Dingle Morning. Cargo load sent north w/BB
04-Feb	79	Tolly Seismic Line done in fast time while camp cleanup and depot work continued by JW and AT. Excess explosives deotnated away from camp in morning.
05-Feb	80	BB Arrived with 4 Avtur Drums. Stayed the night due to weather at SB being pants etc.
06-Feb	81	BB Departs with KM and AC and Cargo Load and one box of Ice Cores. RABID SESIMIC LINE COMPLETRED IN GOOD TIME.
07-Feb	82	GPR of Tyree Seismic line. Crevasse recce near old depot. Camp and cargo prep for uplift.
08-Feb	83	Overwinter GPS station erected. GPR Line done. Depot work continued, marker erected.
09-Feb	84	LIE UP. Blow rolled in overnight. Some depot work completed.
10-Feb	85	Second Day of blow. Cleared in pm, GPS array retrieved.



11-Feb	86	Upstream Blow (westerlies). Tended to camp and doos. Overwinter GPS stn improved.
12-Feb	87	Work tent taken down and misc depot jobs done around camp.
13-Feb	88	Tavi and Andy did one last line of GPR while John and I organized uplift loads and dug out large wxhvn and solar panels; then went crevassing. Aircraft expected tomorrow.
14-Feb	89	Winter depot preparations and camp take down cointinued. Overwinter GPS station tended to.
15-Feb	90	Interior of Wx Haven cleared up and packed away in prep for takedown. Large wxHvn take down. Last of science gear packing done.
16-Feb	91	LIE UP
17-Feb	92	Miscellaneous packing and depot preparation. Crevasse visit in pm.
18-Feb	93	AZ arrived for uplift. 1 Cargo load to Sb and then returned for the night. Depot work and final packing.
19-Feb	94	AZ returned from Sb for one cargo load and then TM and JW taken to SB and swapped pilots for trip to Rothera. IP returned to RABID in AZ and overnighed.
20-Feb	95	Last depot prep and camp pack uip for final uplift flight. Made it as far as Fossil Bluff for night.
21-Feb	96	Fossil Bluff to Rothera!

APPENDIX D - DEPOT DIAGRAM 2005 *(not with this copy)*

APPENDIX E - DEPOT DIAGRAM 2004 *(not with this copy)*

## APPENDIX F -CLOTHING AND EQUIPMENT RECOMMENDATIONS

ITEM	RATING	COMMENTS
Arco Work Gloves (insulated)	Excellent	Universally loved. Take at least 5 pair for a long field season.
Snow Goose Down Jackets	Excellent	Great for a select number of uses; should not be a replacement for RAB Duvet jackets due to large volume.
Cebe Sunglasses	Poor/Unacceptable	Arms awkward, bulky and uncomfortable. Side shields fall off readily; glasses snap in cold – a liability and very poor choice of sunglasses for field use.
Cebe Goggles	Poor/Unacceptable	They let snow and wind in the huge gaps in the side. They are not UV protection and therefore can't be sued as backup sunglasses. Return to the Bolle tinted goggles, please!
Baffin Boots	Varied Opinions	Personally I thought they were sufficient, however they suffer premature wear and tear on liners and result in lots of moisture being trapped inside due to rubber rand. Safety toe is good. Provide everyone with 2 pairs of inners.
3-Man Pyramid Tents	Excellent	Consider buying more and making them available for 2 person trips. Extra room inside a bonus for tall people and for storage of personal items etc.
Rab Expedition Sleeping Bags	Excellent and Poor	Ridiculous amount of unnecessary strings and gadgets inside. FULL LENGTH ZIPPER required in all bags!!!! For ventilation and drying out in warm conditions.
Honda Snowblower	Excellent	Great tool for depot raising and snow management around camp. More should be purchased.
Columbia Socks	Poor/Unacceptable	These socks were an unmitigated disaster. Holes started appearing in the heels after only three days of wear in the filed ad were completely useless after a week.
Komatik Sledges	Excellent	Get more of them / experiment with lashings and decking. Extremely practical and durable.
Siglin Sledge	Excellent	Get more of them and spare parts for towing apparatus
Iridium Satellite telephones and Data Kit	Excellent / Invaluable	
Alpine III Ski Doos	Excellent	
Ski Doo preparation pre-deployment	Poor	The 2 Alpine II Doos sent out for deoting winter 2005 were in poor condition, flat batteries, no GPS mounts etc. Where is the quality control before they leave base?
Field Ops Manual	Excellent	Add Chapter on static camps
Tent Box	New	Build tent boxes (zarges) for large static camps.

## APPENDIX G - REPORT PHOTOGRAPHS (see CD-ROM)

## APPENDIX H – DEPOT CONTENTS LIST

DRUMS OF FUEL TOTAL AVTUR IN 2005 DEPOT 149 AVTUR (SEALED/OK for AIRCRAFT) 50 AVTUR (SEALED/A.N.I. Refills - green drums/OK for AIRCRAFT) 72 AVTUR/DRILLING 27 AVTUR/OILED 6 PETROL 6 EMPTY DRUMS 30

### JERRY CANS OF FUEL

13	x	PETROL
1	x	DOO MIX
8	x	PARAFFIN
3	x	AVTUR

MANFOOD BOXES 20 x MANFOOD BOXES (complete) Note: half the manfood boxes were used to weight down the edges of the tarps and will therefore require some digging to excavate to the surface! The remaining manfood boxes are weighing down items on top of the drums and should be easy to access.

### OILS

15 x ALPINE III INJECTION OIL (1L) 12 x REG 2-STROKE OIL (1L) 5 x DRILLING 2-STROKE OIL (5L) 9 x DRILLING 2-STROKE OIL (25L) 4 x ENGINE OIL (25L) 2 x HARRIER SYNTHETIC OIL (25L) 1 x 15W/40 OIL (5L) 4 x Harrier Synthetic (5L)

### ANTIFREEZE

13 x ETHYLENE GLYCOL (25L)

TIMBERS 4 x 4" x 4" x 4.5m 4 x 2" x 4" x 4.5m 3 x 3" x 3" x 3m 3 x 3" x 3" x 2.5m

PLYWOOD 3 of 1/2" x 4' x 8' ply (rough surface) 1 of 1/2" x 4' x 6' ply 2 of 3/4" x 24" x 8' ply (quasi-marine ply/shiny brown surface) 2 of 3/4" x 30" x 8' ply 2 of 3/4" x 18" x 8' ply

### MISCELLANEOUS ITEMS

3 x Reels of 3mm utility string (200m+ total length)

Assorted Pieces of 9mm and 10mm Rope (various lengths)

Plastic Ice Core Tubes and Insulated Cardboard Ice Cores Box

70+ Glacio-poles 2m

40+ Glacio Poles 4m

15+ Glacio Poles 1m (assorted cut offs) Note: glacio-poles of all lengths vary in condition, some good, some poor)

2 x Drum levers

Broom

Assorted Spare Tarps

SKI-DOOS Over-wintered (2004)

ALPINE III (2002) #3-19 S/N-110462 ODOMETER 2115 km (GA) ALPINE III (2002) #3-24 S/N-112512 ODOMETER 2178 km (BK)

Over-wintered (2005)

ALPINE III (2001) #3-10 S/N-10878 ODOMETER 2360 km ALPINE III (2002) #3-20 S/N-112004 ODOMETER 1685 km

## Appendix I – Static Camp Tent Box

See field reports from Sledge Quebec and India (2004/2005) for additional suggestions.

- Tea Towels (many)
- J-Cloths
- 3 x Large Pots, Large Frying Pan
- Plates, bowls, mugs and cutlery for at least 8 people
- Small whisk; ladle; big spoons/serving spoons; chopping board; big knife; extra dish soap; extra dishes pan; tea towels
- Thermos Flasks
- 2 Basins for dish washing
- Fire Extinguishers
- Fire blankets
- Hooks for Jackets
- Mug hooks
- String for Clothes lines and lashing many things
- Folding chairs; extras for guests/drop ins and needs of other tents (work tent etc).
- Space Heater: Tharrington or Wabasco (upgrade insulation under floor and behind stove;
- 30cm plastic mirror w/hook (for sun screen and general health)
- Small gash bucket
- Water bucket
- Wash bucket
- Hand towels
- Blanket Pins
- Flashlight
- Notepads and writing implements
- Stationary and envelopes
- Good Can opener
- 5L Fuel container
- Multi-Burner Stove
- Small Funnels
- Small carpenter's hand saw for cutting snow blocks

### Additional Recommended Items

- Bulletin Board w/push pins for maps and printouts/cards/letters etc
- White Board and dry-erase markers
- Simple Shelving (empty manfood boxes on their sides, lids removed make decent shelving)
- Iridium Extension Cable (wx Haven foil insulation inhibits signal)
- Light metal shield for above stove area / to line ceiling in wx haven to prevent damage from stove flare ups (fire blankets).
- Ground Insulation (white Jiffy Cell Foam Sheets 2' x 8')
- Plywood flooring: provides durability as well as extra insulation.
- Suspended floor system (see sledge Quebec)
- Ability to open drums for Landfill container: drill/bit/nibbler
- Waste Management systems
- Solar Charging systems to augment 100 Watt system (12V connector splitters/distribution box)
- Plywood or tables/benches for kitchen counter, table and side counters for comms/miscellaneous charging etc.
  
- Music: digital MP3 player recommended
- Bread Maker
- Oven
- Generator (2KW)
- Lights (if Weather Haven tent has no windows and/or insulated ceiling)
- String for washing/drying lines
- DC/portable speakers with Walkman jack
- Tea urn
- Snow Melter: indispensable – see Keith Nichols and Keith Makinson for design specs.
- Cordless Drill, Drill index and Screws for miscellaneous fixes.

## APPENDIX J – CLOTHING AND EQUIPMENT RECOMMENDATIONS

ITEM	RATING	COMMENTS
Arco Work Gloves (insulated)	Excellent	Universally loved. Take at least 5 pair for a long field season.
Snow Goose Down Jackets	Excellent	Great for a select number of uses; should not be a replacement for RAB Duvet jackets due to large volume.
Cebe Sunglasses	Poor/Unacceptable	Arms awkward, bulky and uncomfortable. Side shields fall off readily; glasses snap in cold – a liability and very poor choice of sunglasses for field use.
Cebe Goggles	Poor/Unacceptable	They let snow and wind in the huge gaps in the side. They are not UV protection and therefore can't be used as backup sunglasses. Return to the Bolle tinted goggles, please!
Baffin Boots	Varied Opinions	Personally I thought they were sufficient, however they suffer premature wear and tear on liners and result in lots of moisture being trapped inside due to rubber rand. Safety toe is good. Provide everyone with 2 pairs of inners. - a replacement for the white "Mukluk" is still required for deep field work.
3-Man Pyramid Tents	Excellent	Consider buying more and making them available for 2 person trips. Extra room inside a bonus for tall people and for storage of personal items etc.
Rab Expedition Sleeping Bags	Excellent and Poor	Ridiculous amount of unnecessary strings and gadgets inside. FULL LENGTH ZIPPER required in all bags!!!! For ventilation and drying out in warm conditions.
Honda Snowblower	Excellent	Great tool for depot raising and snow management around camp. More should be purchased.
Columbia Socks	Poor/Unacceptable	These socks were an unmitigated disaster. Holes started appearing in the heels after only three days of wear in the field and were completely useless after a week.
Drum Levers	Excellent	Help reduce manual handling injuries with drum handling during depot work. There are not enough levers to go around for all static field parties and fuel depots.
Siglin Sledges	Excellent	Useful for all kinds of work especially at static camps. Need to stock more spare parts such as towing tongues.
Ski-Doo Helmets	Sizing Poor	Unable to find a ski-doo helmet large enough to fit, while wearing balaclava and/or hat. Purchase the largest sizes possible.
Field Medical Box	Adequate	Trauma Grab-Bag system required for static camps. Med Box awkward and insufficient.

## **RABID Appendix B: Hose loss reports and investigations (including Accident, Incident & Near-Miss Report).**

### **FAILURE OF RABID HOT WATER DRILL**

**Edited by M. Pinnock, 25 August 2005.**

Input/consultation from A. M. Smith, K. Makinson, K. Nicholls and A. Tait (ETS)

#### **1. Issue.**

Following the failure of the hot water drill (HWD) hose during the RABID project in January 2005, John Dudeney requested a report in to the safety, engineering and environmental aspects of the failure. This is not an official enquiry (as defined within H&S legislation) but an information exercise for BAS to inform future operations.

#### **2. Recommendations.**

- 2.1 Note that the RABID drilling operation was conducted within the safety guidelines developed in the risk assessments.
- 2.2 Note that the RABID HWD team produced an appropriate and controlled response to the unexpected failure mode of the hose coupling. Their response entailed levels of risk commonly encountered in field operations and was conducted by our most experienced field operators.
- 2.3 Note that the primary cause of failure was most likely a combination of the softening of both the outer sheath of the hose and the inner hose, and the high axial loads on the hose. The softening probably resulted in a relaxation in the swage's grip, allowing the hose to pull out of the coupling.
- 2.4 Note that the secondary cause of failure was the parting of the backup prusik loop. This was most likely due to abrasion from the capstan wheel weakening the prusik material.
- 2.5 Recommendation, that the present hose design (combination of hose and coupling system) cannot be used for the depths being attempted on the RABID project (ie greater than 2000 m), but should be limited to depths of less than 1000 m to provide an adequate margin of safety (half of the successfully-drilled depth of 2025 m).
- 2.6 That for any attempt to drill to depths greater than 1000 m using a new design of hose/coupling, the new design will need adequate validation either through testing undertaken by BAS, or through collaboration with international HWD operators as appropriate. Depending on the new hose/coupling design, an improved back up system should be introduced to deal with hose coupling failures.

#### **3. Background**

##### **Related Documents**

Appendix A: AINM Incident Report attached to this document.

Appendix B: Report by hot water drilling engineer K. Makinson

Appendix C: Comment on this report from Andy Tait, BAS mechanical Design Engineer

Appendix D: Risk Assessment for RABID Hot Water Drilling (*not with this copy*)

AFI 2004/5 Season report ([http://www.antarctica.ac.uk/afi/Field\\_reports\\_2004-05.pdf](http://www.antarctica.ac.uk/afi/Field_reports_2004-05.pdf)): provides a synopsis of the failure of the HWD (p1); listing of the RABID project objectives, personnel involved and project achievements (pages 7-9).

BAS engineers and scientists have developed the current hot water drilling capability since 1987, conducting six seasons of operation at eleven different sites. This activity, and the science pursued with it, has given BAS a world leading position in the subject of sub-ice shelf water masses. The development of a drill capable of being deployed from Twin Otters, yet able to drill to ~2000m depth, is unique.

The RABID project set the very ambitious goal of reaching the bed (deeper than 2000m) on Rutford Ice Stream. Previously the BAS HWD had reliably reached 940 m. The system had to be upgraded for RABID to do this; primarily an increase in the diameter of the hose and increased water heating and pumping capacity. This development activity was done in close collaboration with the hose manufacturers. The resultant system should be considered as a new, unique drill, rather than simply a modification of an earlier one.

The team conducting the drilling operation comprised some of BAS's most experienced field staff, both in hot water drilling and all aspects of deep field operations – between them they had some 30 seasons experience. As noted in the risk assessment for RABID, in all previous seasons only minor injuries have been sustained and none directly associated with drilling.

#### **4. Safety**

In the meetings held at Cambridge to produce this report it was clear that the team had thought long and hard about the causes of the failure and examined its safety aspects. In particular, it was confirmed that:

- 4.1) All the procedures were being followed and the methods for mitigation of risk were in place and being followed. All PPE was available and was being used.
- 4.2) Only skilled, experienced personnel were leading and operating the drilling equipment.
- 4.3) The equipment was at all times operating within the manufacturers specifications.

Prior to this fieldwork, failure of the drilling hose was considered unlikely. However, the engineer, Keith Makinson, believed that, should failure occur, the most likely failure mode was in the hose couplings. Hence two independent backup systems had been put in place before the drilling operations began. Firstly, a prusik loop configuration was placed permanently around each hose coupling. The second was another prusik system in the drilling pit, which could be attached manually to the hose as required. In fact, in all previous drilling operations there had been no hose coupling failures during actual drilling, except one incident where the manufacturer had not fitted the coupling correctly.

- 4.4) A first failure of a hose coupling occurred when the drill head was at 1980 m drill depth, the coupling failing when it was ~40 m down the hole. As anticipated, the failure occurred close to the surface (i.e. at the point where the full weight of the drill string came on to the coupling). So this failure, whilst surprising, fitted expectations of when a failure might occur. The backup systems worked correctly. The team handled this failure well, effected a full recovery of the failed coupling and replaced it. (The coupling was replaced with the appropriate equipment, to correct tolerances, and was checked prior to use.)
- 4.5) Following the first hose coupling failure, the water temperature was reduced to 75°C (from 90°C) as a precautionary measure (Appendix B, para 6). It was suspected that the softening of the hose sheath material may have been the cause of the first hose coupling failure.
- 4.6) The second failure involved the replaced hose coupling (i.e. exact same point in the hose) and occurred in a more unexpected fashion – whilst the coupling was on the capstan and the drill was being raised (Appendix B, para 7). It should be noted that the (replaced) coupling, prior to its failure, had experienced the hot water flow and the full weight of the drill string below it (>1900m of hose). Once again, the first backup system worked correctly.

- 4.7) No individual was endangered at the time of the failure. In particular, the main hot water feed had been diverted away from the hose already. Whilst some hot water remained in the hose, nobody was close enough to be sprayed by the water.
- 4.8) In the process of attaching the second backup system (the prusik loop in the drill pit), the first prusik loop parted (Appendix B, para 8). The hose, with a coupling on its end, fell down the hole. As it did so it knocked the thumb of the individual (Andy M. Smith) attempting to place the second prusik loop, but no injury resulted.
- 4.9) ***We have considered very carefully the potential for injury to the individual attaching the second prusik loop as the hose accelerated down the drill hole.*** There is a cage which guides the hose off the capstan and in to vertical alignment with the drill hole. This cage, and the weight of the hose in the hole, ensured that the hose followed a straight, vertical path as it went down the hole. ***It did not flail around.*** Thus the greatest risk to the individual was if, with the prusik successfully attached to the hose but before being safely connected to its anchor, he had a limb caught in a loop of it when the first prusik loop failed. This is not dissimilar to many field (mountaineering) situations where limbs caught in loops of rope that suddenly come under tension can cause severe injury. As an experienced field operator the individual was keenly aware of this possibility and guarded against it.
- 4.10) As the hose parted and fell down the hole, all other equipment remained stationary, there was no movement of the capstan.
- 4.11) The failure of the backup prusik loop is most likely due to abrasion of the material by the capstan wheel (Appendix B, para 8). It should be borne in mind that this second failure occurred in an unexpected manner: the coupling was on the capstan wheel, not close to the surface or in the hole. Although the capstan wheel was stopped immediately the failure occurred, some slippage of it was observed and this is thought to have abraded the prusik loop, causing it to part.
- 4.12) ***In conclusion, this particular failure mode was unexpected. The team's actions were done in a calm and controlled manner, with an assessment made of the risks. Attaching the second prusik was a hazardous operation, with potential serious injury if the individual had become caught in a loop of the prusik. However, he was fully aware of this possibility and guarded against it. Given the design of the HWD and the unexpected nature of the incident, the team produced an appropriate response that placed them at a risk level commonly encountered in field operations.***

## 5. Environmental Impact

The loss of more than 1900 m of 1.25" hose, together with a 50 kg brass drilling nozzle and a stainless steel and aluminium reamer, was notified to the FCO by the BAS Environment Office. After the incident the JPL camera probe was lowered down the hole and confirmed that the top of the hose was at a depth of 590 m, well beyond any attempt to recover it. The hose will remain within the glacier at least until it reaches the grounding line (~120 yrs). Modelling of the ice flowline suggests that the hose assembly will melt out of the base of the ice shelf long before the ice front is reached. As all components of the hose (inner, braid, sheath and couplings) are negatively buoyant in sea water, it is most likely that the hose will remain on the seafloor and ultimately be buried in mud. The components present no toxic hazard, to the best of our knowledge.

In any Antarctic field operation there must always be the possibility that equipment will be left in the field. This risk has to be weighed against the scientific return from running the experiment.

## 6. Engineering

This section is kept deliberately brief, as it is clear that any future deep hot water drilling proposal requires a very thorough evaluation of the lessons learned from this incident. With the benefit of hindsight, it is clear that the HWD system has followed a very typical engineering development path: construct a prototype, which is often "over-engineered", that operates successfully; this initial instrument



is then refined or developed through several cycles until a failure occurs. It should always be kept in mind that the requirement to fit the drill in to a Twin Otter has always influenced the engineering solutions and in particular the need for short hose lengths and hence large numbers of couplings.

The chief lessons drawn from this incident are:

- 4.1 The hose coupling is swaged to the hose, it was the swage that failed, not the actual coupling body, nor the hose itself
- 4.2 Failure of the swage was most likely due to softening of both the outer sheath and the inner hose as a result of operating at high temperature (although within the manufacturer's operating limits). Together with the high axial load, this caused the swage of the coupling to separate from the hose.
- 4.3 Testing of the hose was undertaken (see Appendix B, penultimate para) but it is not possible to test under full operating conditions with the facilities available in the UK (see Appendix B, "Suggestions").
- 4.4 Failure of the backup prusik system was most likely a consequence of the unexpected position of the hose failure – on the capstan wheel, rather than below it. Slight slippage between the wheel and the hose occurred before the capstan motion was stopped completely, abrading and weakening the prusik.

Future hot water drilling to depths greater than 1000 m should consider:

- 6.1) Development of an improved hose/coupling system, in particular one where softening of the hose does not threaten the integrity of the hose assembly.
- 6.2) Separating the two functions of the hose coupling such that the tension is taken by an external strain member, with the swaged coupling only containing the water pressure.
- 6.3) The consideration of an automated grab mechanism around the hose, close to the point at which it enters the drill hole, to be activated by strain sensors.

Such developments should be considered in conjunction with other national and international developments in hot water drilling.

An independent comment from Andy Tait (BAS Mechanical Design Engineer) is attached as Appendix C and is in agreement with all of the above.

## Accident / incident / near miss reporting form

Thank you for taking the time to fill in this form. This form is designed not to lay blame, but to help prevent a similar, or worse occurrence from happening again by using the details you give. A confidential section is included on the last page which will not be put into general circulation. Please ask if you need any help.

**Ref number (leave for WBC/BC/Safety officer to enter):** .....

**Name of BC/WBC: Rothera**

**Base/ship/field party:**

Please *X* the appropriate box. Is this a report for a....

**Near miss?** (An event that caused neither serious injury or material damage but, under slightly different circumstances, may have done so.) Or an...

**Incident?** (An event that caused material damage or serious disruption to operations.)

**Accident?** (An event that caused injury or death.) Or an...

Please fill in the following details under the questions:

**Where did this occur (e.g. name of site, building, room, mast, tunnel etc)?**

**Date and time of this event?**

17/01/2005 15:00

**How many people were involved (without mentioning names)?**

**What equipment was damaged if any?**

A swaged hose coupling failed on the hot water drill hose, followed by the failure of the backup prussic rope.

**Was anybody injured (give brief details)? (If yes, then please see the Doctor to enter the medical details in the confidential accident report log.)**

**Were there any contributing circumstances (e.g. weather, tiredness, etc)?**

**Report of what actually happened (give dates and times if necessary)?**

RABID drill winch system and hose coupling failure

The drilling winch comprises of two hose storage drums, each capable of holding up to 450 m of 1.25" bore hose. As drilling progresses additional 200 m lengths of hose are added to the empty hose drums. A capstan unit is used to raise and lower the hose in the hole. The hose is in contact with  $\frac{3}{4}$  of the capstan wheel circumference, or about 3.5 m. This contact area generates sufficient friction to hold the hose with the minimal back tension from the hose storage drums. After the main capstan wheel, the hose passes over three small rollers held in a frame below the winch before the hose enters the hole. Below the capstan unit there is a 2 m deep pit used for attaching the drilling nozzle or borehole instruments.

Throughout the drilling of the first hole to about 1800 m, there were no apparent problems with the hose couplings although bubbles formed under the outer sheath of the hose. This has happened to some smaller hoses in the past and was not considered significant at the time.

The drilling of the second hole proceeded well to a depth of just over 1900 m, when the first hose failure occurred at 40 m below surface. The backup prussics held the hose and allowed its successful recovery. The swage couplings, identical to the factory fitted couplings, were replaced and drilling continued at reduced temperatures, down from 90°C to 75°C to a depth of over 2000 m. The operating temperature was decreased in order to reduce the softening of the sheath material that was now suspected of contributing to the coupling failure.

At 2000 m the drilling was not progressing smoothly so it was planned to raise the hose 100 m and re-drill that section of the hole. The coupling that had just been replaced came onto capstan as normal and most of the water supply was diverted away from the drill. When the hose coupling was near the top of the capstan the failure occurred and water sprayed out from the hose. The water supply was immediately turned off to remove any scalding hazard.

Andy Smith entered pit below the winch and began to put a tape prussic onto the hose (there is no capstan running gear in the pit). The capstan was still turning very slowly and some slippage occurred. The capstan was stopped but this slippage lead to abrasion of the prussic rope reducing its strength (we were unaware of this at the time). In the process of rapping the tape prussic around the hose, the main prussic failed. The coupling, prussic, small mallon and hose passed through the winch roller system and down the hole. Andy received a minor knock to his thumb from the hose as it went down the hole, but there was no injury. Throughout this time the capstan unit remained stable and did not move from its fixed position.

In total 1900 m of hose was lost together with a 50 kg brass-drilling nozzle and reamer unit made from stainless steel and aluminium. Two small data loggers were also lost. Recovery of the hose was not possible, as parts of the hose would quickly freeze to the side of the water filled hole and no grappling system was available. The top of the hose was found at 590 m below surface a few hours later using the NASA/JPL borehole camera. Although the hose will remain frozen into the ice stream, the project had always planned to deploy a total of four instrumented cables through the entire ice column of Rutford Ice Stream.

**Were you aware of the contents of the relevant Risk Assessment(s) concerning this activity before the event?**

**What were the lessons learnt by you?**

**What can we do to prevent this happening (again) - your suggested actions?**

Hose operating specification is 93°C and 2000 psi. A hose coupling had been tested with a static load of 1000-1300 kg at about 25°C but with no water in the hose. At the time of the hose failure, the drill was operating at approximately 75°C, 800 psi and load of 350 kg.

Hose failure is most likely the result of: softening of outer sheath at 90°C that is up to 2 mm thick in parts of the circumference, and some delamination of sheath from rest of the hose had occurred next to the couplings, both effects making slippage from the coupling more likely. These effects are believed to have weakened the swage coupling, leading to its failure.

A new drilling hose may require couplings that include an additional integral strength member to support the hose and a more appropriate sheath material. Increasing the bend radii around the drilling winch would also reduce the stress placed on the couplings as they pass around the winch. The hose couplings would need to be streamlined, with a hose density slightly more than that of water. A reduction in the number of couplings would also be beneficial.

The hose failures were unexpected however the mode of operation assumed that there was a small possibility that failure could happen based on past experience.

**Now, please move on to the confidential section on the last page.**

**WBC/BC/Safety Officer to fill in the following:**

**Actions completed or reasons for not actioning?**

**Include date action completed or Target date for completion**

There's very little to add. The team obviously did everything they could to guard against such an occurrence.

**Which BAS specific and/or generic Risk Assessment(s) are relevant?**

A current copy is available, but I do not have a copy at this moment in time.

**Are the BAS specific and/or generic Risk Assessment(s) relevant to this event comprehensive, adequate and up to date? (If not, please identify the deficiencies.)**

**If the Risk Assessment(s) do not exist or are inadequate, please indicate on what time scale they will be remedied and by whom.**

**Should this report be investigated further? If yes, enter the date by which the investigation should be completed and the name of the investigation leader.**

**Who should this form be circulated to (who can learn from seeing this report - delete or add as appropriate)?**

Local notice board                      Cambridge safety advisor                      Cambridge BC  
Other BCs                      Ships                      Field parties                      Directors  
Any others?.....

**Ref number** (leave for the WBC/BC/Safety officer to enter):.....

**Your name and occupation:**

**Name and occupation of any others involved/Witnesses:**

**Who was injured if anybody?**

**Is there any further information you wish to be kept confidential but which you feel could help prevent a similar event occurring again?**

**Your signature:**

..Steve Marshall.....

Thank you for filling in this form. Please hand this completed form to your WBC/BC/Safety officer who may need to contact you to clarify details.

## **Appendix B: Report by hot water drilling engineer K. Makinson**

### **Incident Details**

A swaged hose coupling failed on the hot water drill hose, followed by the failure of the backup prussic rope.

### **Describe nature of damage**

A total of 1900 m of 1.25" bore hose was lost down the borehole together with a 50 kg brass-drilling nozzle and reamer unit made from stainless steel and aluminium. Two small data loggers were also lost.

### **Statement of what happened**

RABID drill winch system and hose coupling failure

The drilling winch comprises of two hose storage drums, each capable of holding up to 450 m of 1.25" bore hose. As drilling progresses additional 200 m lengths of hose are added to the empty hose drums. A capstan unit is used to raise and lower the hose in the hole. The hose is in contact with  $\frac{3}{4}$  of the capstan wheel circumference, or about 3.5 m. This contact area generates sufficient friction to hold the hose with the minimal back tension from the hose storage drums. After the main capstan wheel, the hose passes over three small rollers held in a frame below the winch before the hose enters the hole. Below the capstan unit there is a 2 m deep pit used for attaching the drilling nozzle or borehole instruments.

Throughout the drilling of the first hole to about 1800 m, there were no apparent problems with the hose couplings although bubbles formed under the outer sheath of the hose. This has happened to some smaller hoses in the past and was not considered significant at the time.

The drilling of the second hole proceeded well to a depth of just over 1900 m, when the first hose failure occurred at 40 m below surface. The backup prussics held the hose and allowed its successful recovery. The swage couplings, identical to the factory fitted couplings, were replaced and drilling continued at reduced temperatures, down from 90°C to 75°C to a depth of over 2000 m. The operating temperature was decreased in order to reduce the softening of the sheath material that was now suspected of contributing to the coupling failure.

At 2000 m the drilling was not progressing smoothly so it was planned to raise the hose 100 m and re-drill that section of the hole. The coupling that had just been replaced came onto capstan as normal and most of the water supply was diverted away from the drill. When the hose coupling was near the top of the capstan the failure occurred and water sprayed out from the hose. The water supply was immediately turned off to remove any scalding hazard.

Andy Smith entered pit below the winch and began to put a tape prussic onto the hose (there is no capstan running gear in the pit). The capstan was still turning very slowly and some slippage occurred. The capstan was stopped but this slippage lead to abrasion of the prussic rope reducing its strength (we were unaware of this at the time). In the process of rapping the tape prussic around the hose, the main prussic failed. The coupling, prussic, small mallon and hose passed through the winch roller system and down the hole. Andy received a minor knock to his thumb from the hose as it went down the hole, but there was no injury. Throughout this time the capstan unit remained stable and did not move from its fixed position.

In total 1900 m of hose was lost together with a 50 kg brass-drilling nozzle and reamer unit made from stainless steel and aluminium. Two small data loggers were also lost. Recovery of the hose was not possible, as parts of the hose would quickly freeze to the side of the water filled hole and no grappling system was available. The top of the hose was found at 590 m below surface a few hours later using the NASA/JPL borehole camera. Although the hose will remain frozen into the ice stream, the project had always planned to deploy a total of four instrumented cables through the entire ice column of Rutford Ice Stream.



## **Risk Assessment**

A current copy is available, but I do not have a copy at this moment in time.

## **Suggestions**

Hose operating specification is 93°C and 2000 psi. A hose coupling had been tested with a static load of 1000-1300 kg at about 25°C but with no water in the hose. At the time of the hose failure, the drill was operating at approximately 75°C, 800 psi and load of 350 kg.

Hose failure is most likely the result of: softening of outer sheath at 90°C that is up to 2 mm thick in parts of the circumference, and some de-lamination of sheath from rest of the hose had occurred next to the couplings, both effects making slippage from the coupling more likely. These effects are believed to have weakened the swage coupling, leading to its failure.

A new drilling hose may require couplings that include an additional integral strength member to support the hose and a more appropriate sheath material. Increasing the bend radii around the drilling winch would also reduce the stress placed on the couplings as they pass around the winch. The hose couplings would need to be streamlined, with a hose density slightly more than that of water. A reduction in the number of couplings would also be beneficial.

## **Addendum re water temperature control.**

The temperature of the water is monitored with an accuracy of better than 0.5 C.

The water temperature for the second hole never exceeded 93 C and was mostly below 90 C. On the first hole the temperature was typically 90 C. However, the temperature did exceed 93 C on 20 occasions, during 18 of these the temperature was above 93 C for up to 18 seconds and reached up to 93.8 C. On one 12 second period it reached 94.5 C. The greatest time above 93 C lasted 45 seconds peaking at 98 C, no drilling was taking place at the time and the water was entering a 'cool' hose.

## Appendix C: Comments on the RABID Report

---

Having read the RABID report I would concur with many of the findings and suggestions raised within the report.

I have spoken further with Keith Makinson concerning the incident, he expanded upon the procedures undertaken and detailed more fully the incidents that had occurred. He provided me with specimens of the connectors and hose that were used.

On inspection of the hose and swage fitting I was struck by the construction of the hose itself. This being made up of three individual un-bonded materials, which combined, had a variable wall thickness along its length.

In all my previous experiences of using swaged hydraulic fittings I have used conventional hoses, where even composite hoses such as steel braided ones have been of consistent wall thickness throughout. This is certainly the ideal recommended arrangement when using swaged fittings.

Given the following:

- The hose is constructed of three individual materials with differing properties. The hard inner tube is covered by the more flexible Kevlar weave which is then covered with pliable outer jacket to protect the Kevlar.
- The Hose and fittings are subjected to differential shear forces as they pass over the main sheave during deployment and recovery.
- Significant axial loads are being applied to the hose and fittings, especially when drilling at depths as great as 2km.
- Both hose and fittings are being exposed to a wide temperature variation from storage temperatures below zero, to working temperatures above 90 degrees C.

The demands on any swaged fitting will be significant and combinations of these will undoubtedly cause a swaged fitting to weaken over time. Indications of a weakening or relaxing of the swage fitting would indeed be accompanied by a distortion of the outer jacket as the hot high-pressure water forces its way between the inner tube and the swage, into the Kevlar weave and under the outer jacket itself. This too would ultimately weaken the swaged connection further.

As a result of the above I would recommend contacting several hose and fitting suppliers to establish if it is possible to reliably and consistently swage fittings to a hose of this type, under these operating conditions. It would be useful to establish whether or not the Kevlar weave would provide sufficient strength as a strain member once the swage has been formed. If this cannot be guaranteed, a secondary strain member may need to be incorporated into the system in order to minimise the loading being placed on the hose and fittings.

In addition, I would agree with Keith Makinson's observations that an increase in the size of the sheave wheel would help reduce the differential loads being placed on the hose and fittings during deployment and recovery. Together with this, a reduction of as many connections as possible would be recommended to further reduce the likely failure points in the hose system.

Andy Tait  
Mechanical Design Engineer.

## **RABID Appendix C: Related links**

- RABID web site <http://ralph.swan.ac.uk/glaciology/projects/rabid/>
- Preliminary RABID field report to AFI [http://www.antarctica.ac.uk/afi/Field\\_reports\\_2004-05.pdf](http://www.antarctica.ac.uk/afi/Field_reports_2004-05.pdf)