

Air Force Institute of Technology

AFIT Scholar

Theses and Dissertations

Student Graduate Works

6-2006

Modeling a Repairable Supply Chain and Applying CPFR Concepts

Sandra A. Mayhall

Follow this and additional works at: <https://scholar.afit.edu/etd>



Part of the [Operational Research Commons](#), and the [Operations and Supply Chain Management Commons](#)

Recommended Citation

Mayhall, Sandra A., "Modeling a Repairable Supply Chain and Applying CPFR Concepts" (2006). *Theses and Dissertations*. 3449.

<https://scholar.afit.edu/etd/3449>

This Thesis is brought to you for free and open access by the Student Graduate Works at AFIT Scholar. It has been accepted for inclusion in Theses and Dissertations by an authorized administrator of AFIT Scholar. For more information, please contact richard.mansfield@afit.edu.



**MODELING A REPARABLE SUPPLY CHAIN AND APPLYING CPFR
CONCEPTS**

THESIS

Sandra Mayhall, Capt, USAF

AFIT/GOR/ENS/06-22

**DEPARTMENT OF THE AIR FORCE
AIR UNIVERSITY**

AIR FORCE INSTITUTE OF TECHNOLOGY

Wright-Patterson Air Force Base, Ohio

APPROVED FOR PUBLIC RELEASE; DISTRIBUTION UNLIMITED

The views expressed in this thesis are those of the author and do not reflect the official policy or position of the United States Air Force, Department of Defense, or the United States Government.

AFIT/GOR/ENS/06-22

**MODELING A REPARABLE SUPPLY CHAIN AND APPLYING CPFR
CONCEPTS**

THESIS

Presented to the Faculty

Department of Operational Sciences

Graduate School of Engineering and Management

Air Force Institute of Technology

Air University

Air Education and Training Command

In Partial Fulfillment of the Requirements for the
Degree of Master of Science in Operations Research

Sandra Mayhall, BS

Capt, USAF

June 2006

APPROVED FOR PUBLIC RELEASE; DISTRIBUTION UNLIMITED.

AFIT/GOR/ENS/06-22

**MODELING A REPARABLE SUPPLY CHAIN AND APPLYING CPFR
CONCEPTS**

Sandra Mayhall, BS
Capt, USAF

Approved:

Dr. William A. Cunningham III (Chairman)

date

Dr. Stephan P. Brady (Member)

date

Abstract

The Air Force supply chain includes parts required to build, fix, or maintain aircraft delivered to the warfighter to carry out missions. Industry has shown that following Collaborative Planning, Forecasting and Replenishment (CPFR) concepts, in particular reducing inventory through accurate demand forecasts, has increased profits in part by lowering holding costs of inventory and increasing sales. This is analogous to the Air Force increasing aircraft availability. There is scant evidence that demand forecasts generated at any level in the Air Force are shared with the intent of coordinating replenishment.

This thesis uses a simple discrete-event stochastic simulation model to show the flow of demand information and parts moving from base and depot to see effects on the pipeline and backorders. Simulated flying hour schedules are used as future demand forecasts.

Table of Contents

	Page
Abstract.....	iv
Table of Contents.....	v
List of Figures.....	vii
List of Tables.....	viii
I. Introduction.....	1
Background.....	1
Research Questions.....	4
Methodology.....	5
Thesis Overview.....	5
II. Background.....	6
Introduction.....	6
Supply Chain Management.....	6
Collaborative Planning, Forecasting and Replenishment (CPFR).....	8
Air Force Logistics Systems.....	9
EXPRESS Version 5.0.....	11
Simulation Modeling.....	12
Arena Simulation Software.....	14
Chapter Overview.....	14
III. Methodology.....	15
Introduction.....	15
Steps in a Sound Simulation Study.....	15
Step 1: Formulate problem and plan the study.....	16
Step 2: Collect data and define a model.....	18
Step 3: Valid conceptual model.....	19
Step 4: Construct a computer program and verify.....	19
Step 5: Make Pilot runs.....	31
Step 6: Validate the programmed model.....	32
Step 7: Design experiments.....	33
Step 8: Make production runs.....	38
Step 9: Analyze output.....	38
Step 10: Document, present and use results.....	38

IV. Analysis	39
V. Discussion, Conclusions and Recommendations.....	45
Suggestions for Further Study.....	45
Appendix A: ARENA Code.....	47
Appendix B: Definition of Terms	55
Bibliography	56

List of Figures

Figure	Page
1. Steps in a simulation study [12].....	16
2. General Repairable Pipeline Concept	18
3. Lean Repairable Pipeline Conceptual Model [16].....	21
4. Base Level in Arena.....	22
5. Depot Level in Arena.....	23
6. Depot Maintenance in Arena.	24

List of Tables

Table	Page
1. Statistics	25
2. Depot Expected Backorder	28
3. Average Pipeline for Base	28
4. Base Expected Backorders At Various Depot Stock Levels	29
5. Expected Total Backorders	30
6. Model Input Parameters	31
7. Forecast Input Parameters	31
8. Adjusted Model Input Parameters.	32
9. Summary of Scenarios	33
10. Two Week Forecast Rate Schedule	34
11. One Week Forecast Rate Schedule	35
12. Four Week Forecast Rate Schedule	35
13. Demand Under Forecast Rate Schedule	36
14. Demand Over Forecast Rate Schedule	36
15. No Change in Demand Rate Schedule	37
16. Depot Under Repair Rate Schedule	37
17. No Change in Depot Repair Rate Schedule	38
18. Paired t-test for Backorder at 99% Confidence	42
19. Paired t-test for Fill Rate at 99% Confidence	42
20. Fill Rate Means and Variances for Operating Procedures	44
21. Fill Rate for Means and Variances for Alternate Scenarios	44

MODELING A REPARABLE SUPPLY CHAIN AND APPLYING CPFR

CONCEPTS

I. Introduction

Background

Industry supply chains are concerned with getting the right product at the right place at the right time. Lowering costs and improving customer service levels are goals that industry tries to achieve by improving their supply chain to match supply to demand [5]. A supply chain encompasses the entire system process to include product design, raw material needs, production, transportation, and recycling [9]. The Air Force with its need to operate and maintain aircraft is no different. Its supply chain includes parts required to build, fix, or maintain aircraft that are delivered to the warfighter to carry out missions. Any improvement in the supply chain of the Air Force means lower costs and greater potential effectiveness (i.e., improved customer service).

According to Logistics Dimensions 2003, Air Force logistics today is conceptually guided by Focused Logistics and Agile Combat Support (ACS) which is based on the Department of Defense Joint Vision 2010 [1]. An October 2003 coordination draft of the joint level Focused Logistics explains that:

the central idea of focused logistics is to build sufficient capacity into the deployment and sustainment pipeline, exercise sufficient control over the pipeline from end to end, and provide a high degree of certainty to the supported joint force commander that forces, equipment, sustainment, and support will arrive on time. [25]

At the Air Force level, ACS is "... the capability produced by the forces and processes that create, sustain, and protect all Air & Space Forces across the full spectrum of military operations [28]."

Improvements in technology and changes in processes, systems, and organizations help achieve the goals outlined in the Focused Logistics Coordination Draft [25]. The draft mentions that potential improvements to logistics systems includes collaboration [25]. Collaboration in industry has led to more cost effective and responsive supply chains by using forecasting models and point-of-sales transaction information to reduce lead times and demand variability [14].

A relatively new concept in supply chain management is Collaborative Planning, Forecasting and Replenishment (CPFR) that uses collaboration as a basis to improve the supply chain. CPFR is a concept that started with sharing forecasts, production and distribution schedules and other information between partners. It has expanded to generation of joint business plans in order to define goals for specific periods, definition of roles of each agency involved, and establishment of rules for items of interest including minimum orders, lead times and order frequency [17]. Although many case studies concerning CPFR deal with consumable products (parts consumed and/or thrown away after use) and not repairable parts (repaired parts that stay in the system until deemed unusable), its concepts are still applicable to a repairable supply chain. Both supply chains have customer demand, order fulfillment, storage, suppliers, and delivery in common but the repairable supply chain has additional issues that deal with reverse logistics (returns and repair). Repairable products are of high interest to the Air Force

since they often involve high cost items and usually have a longer supply lead time or pipeline than consumables.

Industry has shown that following CPFR concepts, in particular reducing inventory through accurate demand forecasts, has increased profits in part by lowering holding costs of inventory and increasing sales [24]. The Air Force has several systems used to forecast demand of reparable parts. These systems are generally based on demand rates calculated once a year and yearly/quarterly flying hour schedules and do not accommodate known flying hour schedules to calculate those forecasts. Known flying hour schedules include scheduled military exercises and deployments where the number of aircraft and missions flown are known or at least well anticipated. Sales forecasts in industry may be equated to the known flying hour schedule and a point of sale as an aircraft available. Even though forecasts are available, they are generally used for budgetary purposes many months/years into the future and for prioritizing placement of demanded parts once they are available for distribution [7].

There is scant evidence that demand forecasts generated at any level in the Air Force are shared with the intent of coordinating replenishment. Demand for aircraft parts in the Air Force is based on a pull system, placing an order when a part breaks down. According to Simchi-Levi et. al., a pull-based supply chain decreases lead time through the near real time demand from retailers and decreases inventory at the retail and manufacturer levels because of the decrease in demand variability. The pull-based supply chain is more suited for supply chains with short lead times since long lead times make it harder to react to demand information. Base demand is pulled from depot inventory versus a push-based system where parts are sent from the manufacturer to

retailer based on a long-term forecast [23]. Because of the long lead time associated with most aircraft parts, having a pull schedule based on demand after parts break can cause longer periods of time the aircraft is not operating than desired. On the other hand, using a push system increases the opportunity of misplacing assets thereby reducing aircraft availability and increasing transportation.

Research Questions

Given the high expense of reparable parts, long lead time for repair, and the Air Force historically using a pull-based system, can the principles of CPFR be applied to effectively improve the Air Force supply chain? This leads to the overarching investigative question: Will using CPFR concepts improve aircraft availability in the Air Force reparable supply chain?

- i. What are the principles behind CPFR? Knowing the principles will lead to understanding how they may be applied to the Air Force supply chain.
- ii. Are there parallels between industry supply chain practices and Air Force supply chain practices? Similarities between commercial and government use will lend CPFR concepts applicable to the Air Force.
- iii. What is the most appropriate method for modeling collaboration in the Air Force supply chain? Choosing the best method to accurately model the supply chain is critical in analyzing the real world situation.
- iv. Can a notional model be built that demonstrates the effectiveness of collaboration? A model that is able to show collaboration is essential to seeing the benefits/disadvantages of collaboration in the supply chain.
- v. Will knowing a demand schedule and using that to order parts before they are broken affect aircraft availability? Determines whether collaboration in the Air Force supply chain is worth pursuing in a large scale study.

Methodology

This paper uses a discrete-event stochastic simulation model to show the flow of demand information and parts moving from base and depot. Demand rates, repair rates, pipeline length, and inventory policies are all notional. The baseline model is the notional system where a base orders parts based on a predetermined demand rate and the depot fills orders based on a repair rate with a set pipeline length. The baseline is compared to other scenarios where demand schedules determine parts ordered and filled. Experiments are conducted to see the behavior of the model under various conditions and to determine variable(s) with the most influence on the model.

Thesis Overview

Chapter One was an overview of the importance of supply chain management to the Air Force, a similarity of the Air Force to industry, and the problem description with methods for analysis. Chapter Two contains research on various subject matters that are important in understanding supply chains, CPFR, and forecasting demand in the Air Force. It touches upon current Air Force models to determine aircraft availability and information on computer simulation modeling. Chapter Three describes how the study was conducted. Chapter Four presents analyses of the simulation model and Chapter Five contains conclusions, recommendations, and areas of future analyses.

II. Background

Introduction

This chapter discusses supply chain management and repairable versus consumable parts, concepts of collaboration and how industry has applied CPFR, current logistics supply systems in the Air Force and their uses, and why simulation modeling was chosen and some basic modeling concepts.

Supply Chain Management

The supply chain is the collection of all components and activities associated with the creation and delivery of a product or service. Logistics encompasses transportation, distribution, warehousing, material handling, and inventory management processes [9]. Supply chain management addresses not only the supplying of a product to meet demand but also encompasses all the processes from product design, production, product promotion, and order fulfillment all the way through end-of-life recycling and disposal [11].

In an article from the Spring 2003 MIT Sloan Management Review, Kopazak and Johnson discuss how supply chain management has undergone six key shifts in the way managers think about their businesses and their partners. Among the six is the shift from focusing on supply to focusing on demand. Where management used to ask how to improve the way they supply product given the demand, they now ask how to get earlier demand information or how they can affect the demand pattern to match supply and demand. This shift led to three breakthroughs, reduction of the bullwhip effect, demand-based management and investment in better demand information [11]. The

bullwhip effect is of greater interest for the purposes of this paper since management strategies and the types of shared information are not under question.

The bullwhip effect represents the situation where demand variability amplifies as one moves up the supply chain away from the customer. A classic example noted in many supply chain and logistics textbooks is the Proctor & Gamble (P&G) order pattern for one of its best-selling products, Pampers diapers. Customers consumed diapers at a steady rate but as the P&G logistics executives examined demand variability, they found increasing variability as the order progressed upstream toward its materials supplier. P&G called this phenomenon the bullwhip effect. They discovered the main culprit of the bullwhip effect were component suppliers up the chain ordering raw materials to make additional components and procure some material for safety stock. The next up the chain does the same and so on. The deviations from planned orders were magnified going up the chain. [13]

Lee, et al. identified four major causes of the bullwhip effect: demand forecast updating, order batching, price fluctuation, and rationing and shortage gaming [13]. Research on determining the impact of demand forecasting on the bullwhip effect conducted by Chen, Drezner, et al. for a simple two-stage supply chain has shown that providing each stage of the supply chain with complete access to customer demand information can significantly reduce the increase in demand variability and hence lessen the bullwhip effect [4].

Industry supply chains have traditionally oriented towards consumable parts or parts not repairable as seen in the P&G example above. As companies mature and move

into the replacement market, concern for parts that can be repaired becomes relevant and adds to the complexity of the supply chain. This concept, also called a reverse supply chain, deals with returns, repairs, and upgrades of products. The market for the Air Force has long been mature, there isn't new market development and the Air Force still "sells" to the same type of customer, and the need to recover as much of its assets has long been a concern due to budget constraints and the non-availability of new parts to replace those broken. According to a Booz Allen Hamilton report concerning mobile device returns and repairs, a root cause of inadequate returns handling is the inability to forecast returns. One suggested solution includes using forecast returns and sharing that information along the supply chain so that suppliers are better informed and prepared. [20]

Collaborative Planning, Forecasting and Replenishment (CPFR)

Collaborative Planning, Forecasting and Replenishment (CPFR) is a business model that integrates all stages in the supply chain by sharing information to the benefit of all partners. In 1998, the Voluntary Interindustry Commerce Standards (VICS) compiled CPFR voluntary guidelines to serve as a road map for distributors, suppliers, and third-party providers of software and logistics [27]. The guidelines explain the underlying business processes, supporting technology, and management issues that should be addressed in implementing CPFR [17].

CPFR begins with collaborative planning among the partners to agree upon a business plan. Information including demand forecast is shared using an automated process so data is accessible to all partners. Using the plan as a forecasting tool for non-CPFR participants in the supply chain allows automatic generation of shipping plans

without having to wait for order inputs. This cuts down on lead times for product delivery. CPFR can also lower inventory due to advance notice for promotion sales or supply constraints among the partners.[27]

Joe Andraski, Senior Vice President of OMI International, has been quoted as saying “the real magic of CPFR is real-time information the entire supply chain can use to respond to demand [14].” According to an article by Walter McKaige 2001, the core objective of CPFR is to increase the accuracy of demand forecasts and replenishment plans [17]. Surveys and case studies have shown the positive effect CPFR principles, including accurate demand forecasts, have on improving the supply chain [24].

In 1999, Ace Hardware initiated its first CPFR relationship with one of its vendors, Manco. Among its goals for implementing CPFR, Ace Hardware hoped to improve the visibility of products in the pipeline and into the manufacturers' inventory. Web-based software allows Manco access to Ace Hardware's computer system that maintains forecast plans based on store sales. Both Ace Hardware and Manco have the opportunity to agree upon the demand forecast before it brings that forecast into its production planning system in real time. The benefits Ace attributes to CPFR with Manco is the significant improvement in its forecast accuracy from 80 to 90 percent, freight costs as a percentage of product costs dropping from 7.0 to 2.5 percent, and fill rates of 99 percent in store orders. [6]

Air Force Logistics Systems

The Air Force repairable supply chain operates in a pull based two-echelon environment with bases in the first echelon and depots in the second echelon [22]. Each base maintains a stock of parts that has been pre-determined and tries to maintain an

inventory position. Inventory position is the number of parts on hand plus number of parts on order minus the number of parts on backorder [15]. When failure of a part or demand occurs at the base, the base inventory position decreases by one and triggers an action to bring supply back up to its target level. The replenishment action may entail entering that part into base repair or if not repairable this station (NRTS), a return of the part to the depot along with a request for a serviceable part. When the depot receives the demand, it sends a serviceable part if available and enters the failed part into repair or determines the part is not repairable and condemns it. A backorder occurs when a serviceable part is not available causing an aircraft to sit idle. It is useful to think of the total base pipeline as composed of three parts:

- base repair pipeline,
- order and ship pipeline of assets matched with requisitions in transit to the base, and
- depot delay pipeline of requisitions being delayed at the depot until a serviceable asset is available.

The term pipeline helps visualize the flow of information and parts between the base and depot. This simplistic view of the Air Force supply chain does not take into consideration supply opportunities from other bases nor cannibalization, the practice of attaining serviceable parts from other aircraft.[15]

In a 2000 report from the Logistics Management Institute (LMI) the Air Force uses four information systems to determine supply levels. They include the

Requirements Execution Availability Logistics Module (REALM), D041¹ and Aircraft Availability Model (AAM), the Readiness Based Leveling System (RBL) in D035, and the Execution and Prioritization Repair Support System (EXPRESS). Of these systems, EXPRESS considers both demand rates and flying hour schedules to determine forecasts. It is used as a tool to determine prioritization of depot repair and filling base requirements. [15]

EXPRESS Version 5.0

The Execution and Prioritization of Repair Support System (EXPRESS) is an automated system designed to improve and streamline operations under Air Force Agile Logistics initiatives and logistics reengineering efforts. Used as a decision support tool for reparable, its main purpose includes increasing the level of support and responsiveness to customer needs. It does this by concentrating on key processes that include identifying repair requirements, prioritization methodologies, supportability analysis of repair resources and output interfaces. Communication between all levels is considered very important for employment of the processes. Because what one user does to EXPRESS affects other users, communication ensures that the information entered into the system will not adversely affect another level or unit. [2]

EXPRESS as a collaboration tool has many benefits. It relates actual repair determination to planned operational tempo and provides latest daily asset disposition. It also supports the depot level logistics chain by prioritizing daily repairs, identifying constraints, and distributing assets where they are most needed according to established

¹ D041 has been replaced by D200 since the LMI 2000 report.

business rules. Automation has enabled faster handling of parts with regard to both repair and distribution.[7]

Along with benefits, the system also had problems such as a high number of backorders that led AFMC/XPS to conduct a study to determine which forecasting method provided the most accurate forecast in EXPRESS when compared to actual consumption at the bases. Accurate forecasts enable higher level of repair and distribution prioritization thereby reducing backorders. The three methods under discussion were daily demand rates, flying hours, and deepest holes (biggest deficit). EXPRESS uses flying hours for aircraft parts and daily demand rates for all non-flying parts to predict future demands. The study found the daily demand rate method to be the most accurate tool for forecasting when compared to actual repair determination for the period of the study. However, the study recommended using the flying hours method as a long term planning tool for horizons of 60 days since updating the system every day was deemed labor intensive and a 60 day forecast would provide accurate enough information. [8]

Simulation Modeling

There are three general models frequently used to analyze logistics planning problems. These models are analytical, heuristic, and simulation. Analytical models use mathematical methods to find an optimal solution. Heuristic models use recommended procedures based on knowledge of the problem. Solutions using heuristic models are managerially acceptable and may not lead to an optimum; rather they lead to best solutions given existing limitations and criteria and are generally used when finding an optimum solution is not feasible. Analytical and heuristic models are deterministic in

nature, for example, given the same data and assumptions, the solution will always be the same when the method is repeated [3]. These models aggregate data and do not have the capacity to consider individual entities or products in a system. As a result, they are not suited for processes in which individual entities have an impact on the state of the system [19]. Simulation is used when uncertainty and variance become important because of its capability to include stochastic situations. It introduces probability into the analysis of a problem [3]. Discrete-event computer simulations often deal with modeling of systems that are too complex to undergo a numerical analysis and/or are too expensive to experiment with physically [10].

The goals of simulation are varied and include measuring system performance, improving operations, as a decision tool for management, or simply defining how the system works [10]. Simulations may graphically show the flow of a process through representations of the system and through animation. Further, simulation models can accurately portray actual system phenomena such as individual entity queue behavior, inter-arrival time, and variable service speed that would make analytical equations hard to compute and understand [19]. According to the principles laid out in *Operation Procedures Principles and Practice* by Ravindran, Phillips, and Solberg, the first principle is to keep the model as simple as needed. Depending on the purpose of the model, building a complicated simulation will only confound the solution being sought. Given two models that accomplish the same goal, the simpler model is often most desirable in regards to cost of development and ease of understanding [18].

These factors make simulation modeling an ideal methodology for applying alternative operating rules and characteristics to the simplified Air Force reparable pipeline proposed.

Arena Simulation Software

This thesis utilizes Arena 5.0 Standard Edition Simulation Software for the development and analysis of the reparable pipeline model. Arena provides a flowchart-style environment to create and run experiments on models. Modules from a number of templates can be dragged into a model window and connected to define process flow. Information specific to the system may be added to each module through data forms.

Arena is a Rockwell Software package used by more than 6,000 users worldwide. The software has been successfully utilized by numerous companies such as Dow Chemical, United Parcel Service, Ford, and General Motors and many have used Arena successfully to improve business performance [21]. The simplified Air Force reparable pipeline simulation model created in Arena and its supporting logic is available in Appendix A of this thesis.

Chapter Overview

This chapter discussed supply chain management and reparable versus consumable parts, concepts of collaboration and how industry has applied CPFR, current logistics supply systems in the Air Force and their uses, and basic concepts of simulation modeling and why ARENA 5.0 was chosen.

III. Methodology

Introduction

This chapter describes the Arena simulation model and methods used to answer the research questions. This chapter uses steps in a sound simulation study as presented by Law and Kelton in *Simulation Modeling and Analysis* to discuss modeling concepts and requirements for the research model. An existing Arena model and modifications necessary to reflect the needs of this research is also presented. The chapter also discusses statistical methods used for analysis.

Steps in a Sound Simulation Study

In order to understand and analyze a problem, there is a need to understand and be able to translate the problem into a workable computer simulation and analyze the output of the simulation. Figure 1 shows recommended steps that encompass the formulation and usefulness of a sound simulation model. The steps are part of an iterative process and may be repeated as necessary until the simulation meets the needs of the users. [12] While explaining the steps, this section will also describe specifics dealing with the research.

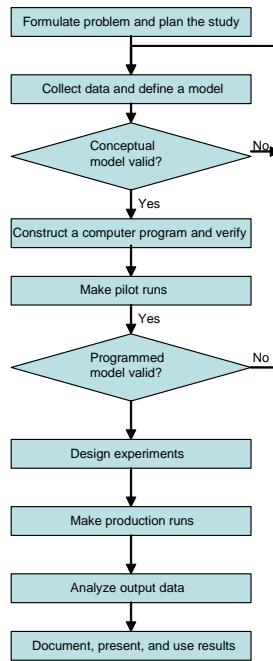

Figure 1. Steps in a simulation study [12]

Step 1: Formulate problem and plan the study.

The first step involves understanding the problem in order to decide overall objectives, specific questions to be answered, and the scope of the problem. As outlined in Chapter 1, the overall objective of the research is to see if improvements of the Air Force repairable supply chain can be achieved using CPFR principles. Specifically, does sharing demand information about upcoming exercises or known deployments help in satisfying the demand of repairable parts at base level from the depot.

In order to concentrate on the demand aspect, parts of the repairable supply chain are simplified and defined to formulate the scope. The problem considers only one base, one depot, and one part with a fixed length of order and ship time. This reduces the

variability of repair at the depot, of demands of parts from bases, and of the order and ship time. Order and ship time is the length of time from placing a resupply request at the base until the item is received from the depot. Repair occurs only at the depot with no lateral supply from other bases or cannibalization of parts. Collaboration of demand information between the base and depot is of consideration so repair at the base is not significant and in the interest of keeping the scope simple, lateral supply and cannibalization is not considered. All parts can be repaired hence no condemnation of parts. Again in the interest of simplification, all items can be repaired and stay in the system. A fixed inventory with a break one, buy one or (S-1, S) inventory policy is applied for every echelon [22]. Repair is based on a first come first serve basis with no prioritization and begins after an order and broken part from the base is received at the depot. According to Air Force Policy Directive 20-3, the Air Force has a repair on demand policy defined as “the ability to quickly and individually induct and repair a range of different reparable assets, rather than repairing batches of like assets to achieve efficiencies in workload and bit/piece contracting” [26].

Improvements in reparable supply pipelines and satisfying demand may be measured by how quickly demand is met. In order to measure improvement, information on demand, backorders, and fill rates should be collected. Backorders are the number of times the base waits for a part it has ordered and fill rate is the rate at which demand is

met calculated by $\frac{\text{demand} - \text{backorder}}{\text{demand}}$.

Step 2: Collect data and define a model.

The next step involves collecting information for designing the model such as system layout and operating procedures and collecting data to specify model parameters/ inputs into the simulation.

Model Concept

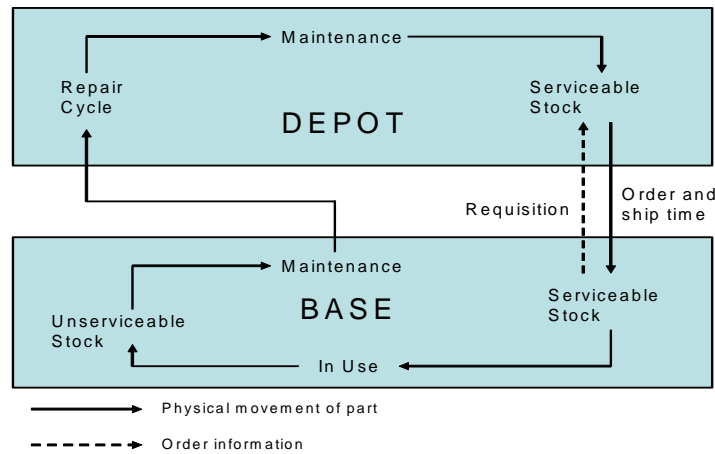

Figure 2: General Reparable Pipeline Concept

As stated in the background section, a general Air Force multi-echelon reparable pipeline may be described as having three main parts: 1) the depot, 2) the base, and 3) the order and ship time function to provide parts to base maintenance, to flow requisition information to depot) [15]. For the purposes of this thesis, the base consists of a supply function to provide parts to base maintenance, to flow requisition information to depot supply, and have a base maintenance function to generate the demand of parts. The depot consists of a depot maintenance function that repairs the parts inducted by base supply and a depot supply function that maintains serviceable stock to replenish base stock levels and depot stock levels. The order and ship time dictates the length of time it takes

for an order from the base to reach the depot and the length of time it takes to send a serviceable part from the depot to the base and will be a fixed unit of time for simplification. The demand information shared between the base and depot is a one time notification of parts required. For example, the base knows it needs ten extra parts in two weeks the depot will react by increasing its repair rate to a predetermined level for a certain length of time to meet the demand if required.

Step 3: Valid conceptual model.

After defining the conceptual model, validation of the model by experts ensures the model's assumptions are correct and complete. This step helps to avoid significant reprogramming later if the model turns out not to fit the needs of the user. If the conceptual model is not valid, assumptions are revisited and the conceptual model is redefined. This step was accomplished through discussions with Air Force logistics subject matter experts who are familiar with the Air Force supply and replenishment process.

Step 4: Construct a computer program and verify.

Once the model passes validation, a computer program is written and verified to run correctly under the defined assumptions. Verifying the model entails debugging the computer programming and fixing any problems inherent in the computer model not the conceptual model.

A lean repairable supply pipeline model built using Arena by Captain Melvin Maxwell provides the necessary aspects of the repairable supply chain model for this research. The model was modified to reflect the supply chain aspects of interest and to capture key performance parameters (see Table 6). According to a white paper by

Rockwell Automation, modifying an existing model is a valid method of simulation modeling [21].

The model is a notional model that simulates a lean repairable pipeline. It represents a simplified version of the Air Force repairable pipeline with its repair portion operating under lean principles of pull and just-in-time production [16]. As discussed in the background, in a pull system orders are filled after demand is carried upstream to the supplier [23]. Just-in-time production means producing the right item at the right time in the right quantity [16]. The repair portion of the model uses a repair on demand methodology and exhibits a relatively stable repair rate matching expected system demand. The model before modification for this thesis considers three bases, one depot, and one part when in reality, the Air Force has many more bases and depots where many repairable parts are processed. It is intended to represent the higher level routing paths and interactions of the real system to represent the macro level effects of the lean approach on overall system performance. Lateral supply, cannibalization, and condemnation are not represented in order to simplify model construction. [16]

The closed-loop model simulates the movement of demand information of one part type at three bases and one depot. As seen in Figure 3, the model consists of four stages: 1) base supply, 2) base maintenance, 3) depot supply, and 4) depot maintenance. Two directions for information and parts movement exist. Parts are demanded at base maintenance and the information is passed to base supply. Base supply inducts the part into repair and fills the demand if possible. If the part is not available, the demand is flowed to depot supply. Depot supply checks to see if the part is in stock and fills the base to stock level if possible. The broken parts flow from base maintenance to depot

maintenance where it is repaired then sent to depot supply and finally to base supply to fill the demand [16].

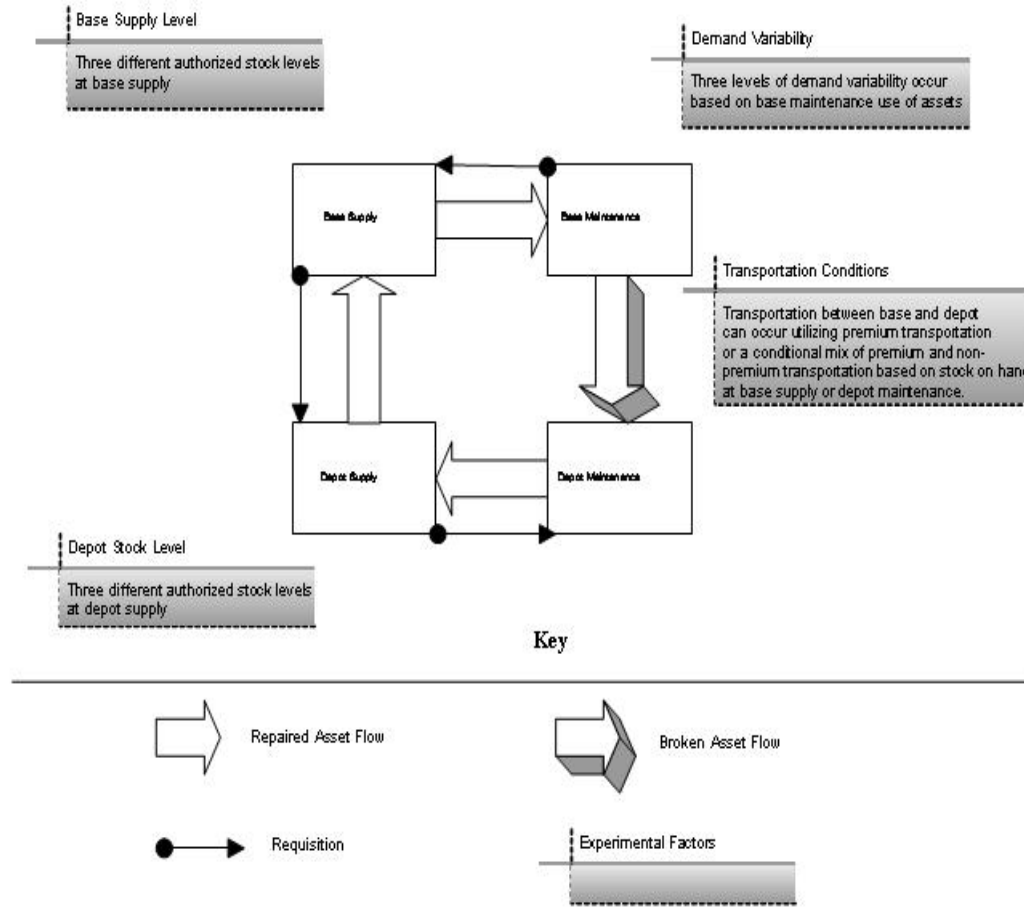

Figure 3: Lean Repairable Pipeline Conceptual Model [16]

Changes were made to the existing model to reflect the conceptual model defined in previous steps. The modified model includes only one base, one depot and one part with a fixed order and ship time. Initially, the base (Figure 4), notionally called Seymour Johnson, has a create supply block that establishes the inventory level. It is set to create a number of entities to represent parts at time zero of the simulation. An initial demand of one is created at simulation time zero in order for the simulation to move forward in time.

Entities are used in four ways at this level, as a matched supply/demand part for base usage, as a demand order to the depot, as a demand order at the base, and as a failed part that is sent to the depot. At the Seymour Johnson Supply match block, demand is matched with supply and batched together to create one entity. Batching the demand and supply together represents pairing of an order request with an asset. The part waits in a queue when no demand is present and conversely, if the part is not present the demand waits in a queue. The batched supply/demand entity is duplicated to serve as the demand order to the depot supply for replenishment of the part in use. The matched supply/demand part is delayed to represent usage of the part by the base after which the part is considered failed and is duplicated to represent a demand requirement at the base. This demand order cycles back to the beginning match block and is waiting in queue as demand at the base. The matched supply/demand part is sent to the depot and represents the physical part sent to depot maintenance for repair. The transportation portion of the pipeline is a wait block and may be set to any constant to represent a fixed length of time for transportation.

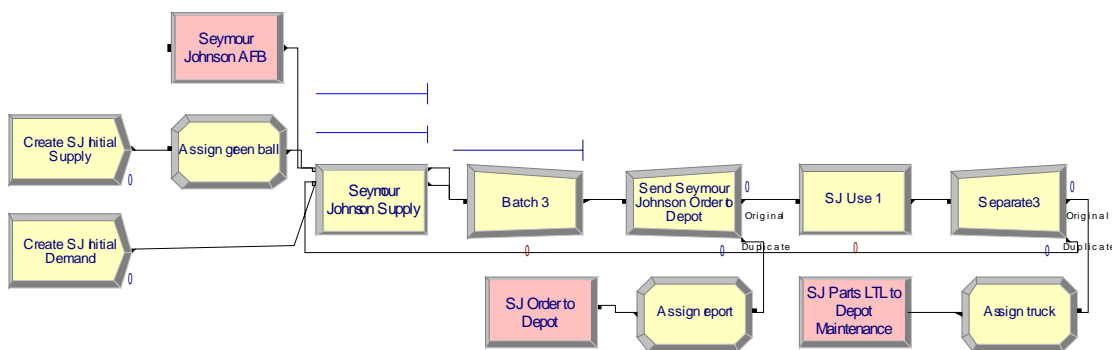

Figure 4: Base Level in Arena.

The depot supply portion shown in Figure 5 also has an initial inventory level set by a create block at simulation time zero. Demand requests from the base are matched with parts from depot inventory or in the case when there is no inventory, from parts exiting depot maintenance. Similar to the base, if a demand exists but no part is available, the demand waits in a queue and if a part exists but there is no demand, the part waits in a queue. The matched demand and supply is then batched together to have one entity and duplicated so that one is sent to the base as part ready to fill base demand and to depot maintenance to signal that it should fix another part to replenish the depot inventory.

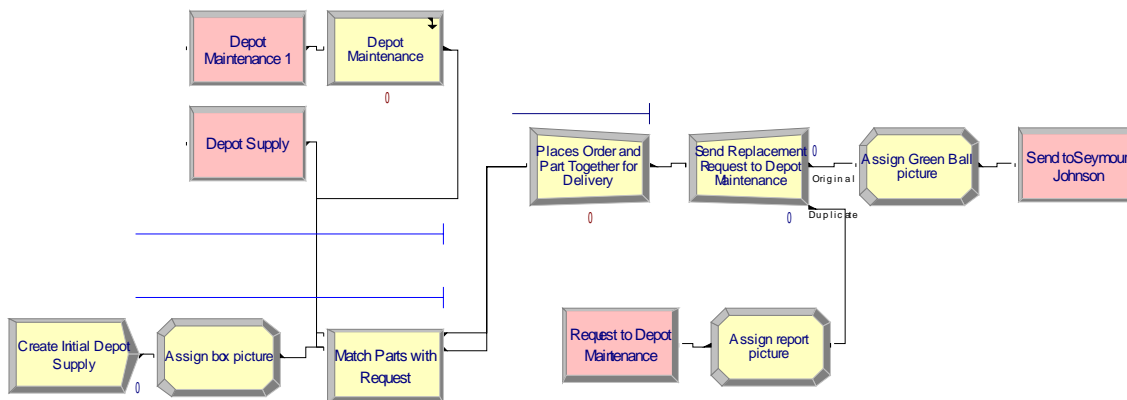

Figure 5: Depot Level in Arena.

The depot maintenance portion is a submodel that represents the repair on demand capability of the depot. As seen in Figure 6, a decide block is used to distinguish between a part order and a failed part and sent to the appropriate queue in the next block. Once a request of repair from depot supply and the failed part sent from base

maintenance are matched, they are sent to the batch block to become one entity. This depot maintenance assumes only one repair at a time so a hold block is used to keep the entity ready for repair until the repair block is empty. The entity enters the repair block and is delayed for a length of time to represent a repaired part. The repaired part then flows to the match block mentioned in the depot supply portion above.

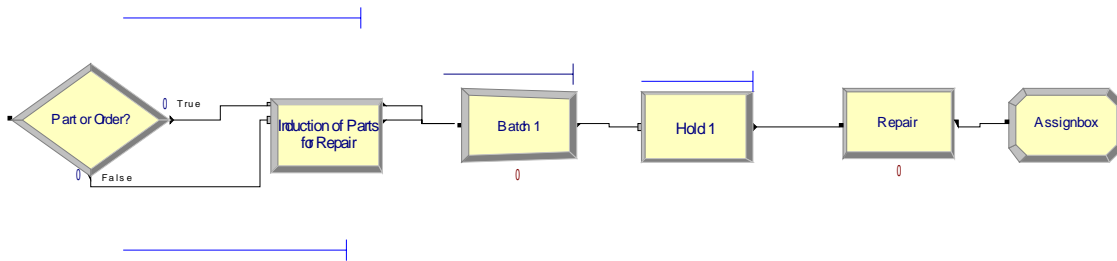

Figure 6: Depot Maintenance in Arena.

Table 1 shows the statistics to be collected to measure performance of the model. Total Demand is collected by counting the number of entities passing through the SJ Use 1 block. Demand over time is collected by using a time-persistent statistic which records into a file every time the SJ InUse1 queue changes and the time at which it changes. Total backorders is calculated by counting the number of times a demand exists when there are no parts to fill it in the match block of the base section. Backorders over time is collected similarly to demand over time with a time-persistent statistic in the match block queue for demand waiting parts. Fill rate is calculated by the number of demand minus the number of backorders all divided by the number of demand. Fill rate over time is a

time-persistent statistic that records the statistics into a file every time the values in the equation changes.

Table 1: Statistics

Measures of Performance
Total Demand
Demand over time
Total Backorders
Backorders over time
Fill Rate
Fill Rate over time

Specifics for base inventory, depot inventory, demand rate, repair rate, and order and ship time can be specified by the programmer in the ARENA model. In order to determine the initial inventory levels at the base and depot, a mathematical model called the Multi-Echelon Technique for Recoverable Item Control (METRIC) created by Sherbrooke in 1968 is used. METRIC gives a theoretical level of stock at each echelon in order to minimize expected backorders. It uses the Poisson process to describe events according to Palm's Theorem which is the basis of Sherbrooke's model. METRIC has been used by manage critical spare parts in the military and is accepted by the community as a standard practice. Assumptions for using METRIC include

- i) Independent and identically distributed (i.i.d.) random variables. A collection of random variables is i.i.d. if the random variables have the same probability distribution as the others and all are mutually independent. Independence implies that knowing information about the value of one variable does not give information about another.

ii) A stationary and random demand. A stationary process is a stochastic process in which the probability density function of some random variable X does not change over time or position. As a result, parameters such as the mean and variance also do not change over time or position. A probability density function is any function $f(x)$ that describes the probability density in terms of the input variable x so that $f(x)$ is always positive and the total area under the graph is 1.

$$\int_{-\infty}^{\infty} f(x) dx = 1$$

iii) The base is resupplied from the depot and lateral resupply, condemnation, or cannibalization does not occur.

iv) A $(S-1, S)$ inventory policy, or loose one-get one policy, is appropriate for every echelon therefore items are not batched for repair.

The steps for the Metric procedure are as follows:

- 1) Start with a depot stock level of zero
- 2) Compute the average resupply delay at the depot and the average pipeline to each base
- 3) Calculate the expected backorder for each level of base stock for each base
- 4) Use marginal analysis to combine the base backorder functions and obtain the minimum backorders for each number of units at bases.

- 5) If the level of depot stock is large enough, go to step 6; otherwise, increase the depot stock level by one and go to step 2
- 6) Find the minimum value on each diagonal representing the same number of units in stock. Drop any nonconvex points.
- 7) Repeat step 1-6 for each items.
- 8) Use marginal analysis to combine the item solutions, where the first differences are divided by the item costs.

Steps 7 and 8 can be ignored since this model only has one item. The following definitions and equations are used in METRIC. [22]

Definitions

- m_j : demands per day
- T_j : average repair time in days
- r_j : probability of repair at location
- O : average order and ship time from depot to base in days
- S_j : stock level
- μ_j : average pipeline
- depotEBO: expected backorders at depot at various stock levels
- baseEBO: expected backorders at base at various stock levels at a certain depot stock level

subscript $j=0$ denotes depot, $j=1$ denotes Seymour Johnson AFB

- $m_1 = \text{mean of EXPO}(2) = 0.5$
- $m_0 = m_1 * (1-r_1) = 0.5$
- $T_1 = 0$ (no repair at base)
- $T_0 = \text{mean of TRIA}(2,3,4) = (2+3+4)/3 = 3$
- $r_1 = 0$ (no repair at base)
- $O = 5$
- $\mu_0 = m_0 T_0 = 1.5$

Depot Expected Backorders

$$depotEBO = (\mu_o - S) \sum_{x=0}^{S-1} S \times P(X = x)$$

Table 2: Depot Expected Backorder

S	Poisson	EBO
0	0.22313016	1.5
1	0.33469524	0.72313016
2	0.25102143	0.280955561
3	0.125510715	0.089802391
4	0.047066518	0.024159937
5	0.014119955	0.005584
6	0.003529989	0.00112802
7	0.000756426	0.000202028
8	0.00014183	0.000032

Average pipeline for demand at Seymour Johnson

$$\mu_1 = m_1 (r_1 T_1 + (1 - r_1)(O + depotEBO(S = 0) / m_o))$$

Table 3: Average Pipeline for Base

Depot stock	μ_1
0	4
1	3.22313
2	2.780956
3	2.589802
4	2.52416
5	2.505584
6	2.501128
7	2.500202

Base Expected Backorders

$$baseEBO = (\mu_1 - S) \sum_{x=0}^{S-1} S \times P(X = x)$$

Table 4: Base Expected Backorders At Various Depot Stock Levels

		Total Stock at Base							
Depot Stock Level	0	1	2	3	4	5	6		
0	4.0000	3.0183	2.1099	1.3480	0.7815	0.4103	0.1954		
1	3.2231	2.2630	1.4312	0.8063	0.4036	0.1801	0.0721		
2	2.7810	1.8429	1.0773	0.5513	0.2475	0.0981	0.0346		
3	2.5898	1.6648	0.9342	0.4552	0.1934	0.0723	0.0240		
4	2.5242	1.6043	0.8867	0.4243	0.1767	0.0646	0.0210		
5	2.5056	1.5872	0.8734	0.4157	0.1721	0.0626	0.0202		
6	2.5011	1.5831	0.8702	0.4137	0.1710	0.0621	0.0200		
7	2.5002	1.5823	0.8695	0.4133	0.1708	0.0620	0.0199		
	7	8	9	10	11	12	13	14	
0	0.08476	0.03363	0.01226	0.00413	0.00129	0.000376	0.000103	0.000026	
1	0.02602	0.00854	0.00256	0.00071	0.00018	0.000043	0.000010		
2	0.01098	0.00315	0.00083	0.00020	0.00004	0.000009			
3	0.00713	0.00192	0.00047	0.00011	0.00002				
4	0.00609	0.00160	0.00038	0.00008					
5	0.00582	0.00152	0.00036						
6	0.00576	0.00150							
7	0.00574								

The minimum value on each diagonal is highlighted in Table 4 and presented in Table 5. To guarantee an optimal solution, convexity of the expected backorder function is required. Convexity is determined by looking at the backorder reduction to see if the values are monotonically decreasing. All of the solutions are convex therefore guaranteeing an optimal solution of minimum expected backorders at the various stock levels. The depot stock level of two and base stock level of twelve are chosen for the model since it has the lowest number of total expected backorders.

Table 5: Expected Total Backorders

Total Stock	Depot	Base	Total Backorders	Backorder Reduction	Convexity
0	0	0	4.00000		*
1	0	1	3.01832	0.98168	*
2	0	2	2.10989	0.90842	*
3	0	3	1.34800	0.76190	*
4	0	4	0.78147	0.56653	*
5	1	4	0.40364	0.37783	*
6	1	5	0.18012	0.22352	*
7	1	6	0.07206	0.10806	*
8	1	7	0.02602	0.04604	*
9	1	8	0.00854	0.01748	*
10	1	9	0.00256	0.00598	*
11	1	10	0.00071	0.00186	*
12	1	11	0.00018	0.00053	*
13	1	12	0.000043	0.00014	*
14	2	12	0.000009	0.00003	*

The demand rate, repair rate, and order and ship time are determined from talking with logistics experts for what would be reasonable for a reparable part. Table 6 lists the model input parameters and their values. An exponential distribution is used to describe the Base Usage Rate since delaying a part represents usage or the time between demand. In a Poisson process the time between events follow an exponential distribution. A triangle distribution is used for the depot repair rate because of the unknown characteristics of the true repair rate.

Table 6: Model Input Parameters

Model Inputs	Value
Depot Repair Rate	Triangle(2,3,4) days
Base Usage Rate	Exponential(2) days
Ship Time From Base to Depot	5 days
Ship Time From Depot to Base	5 days
Base Stock Level	12 items
Depot Stock Level	2 items

In order to simulate the demand forecast portion of the model, schedules for usage and repair are used. Reaction of the depot to the forecast is assumed to be an increase or decrease in the rate of repair for a length of time. For example, the base knows of an exercise where it will use ten extra parts over two weeks. The base informs the depot two weeks in advance. The depot once notified, increases repair for a length of time to meet the demand while the base continues to request parts at its current rate. After two weeks, the base goes into the exercise and increases demand as forecasted. Table 7 shows sample values for the forecast rates for usage and repair.

Table 7: Forecast Input Parameters

Model Inputs	Value
Base Forecast Usage Rate	Exponential(1.5) days
Depot Forecast Repair Rate	Triangle(1,1.5,2) days

Step 5: Make Pilot runs.

Pilot runs are conducted in order to validate the computer model. This validation entails comparing performance parameters of the model and an existing system, if there is one, reviewing for correctness, and conducting sensitivity analysis to see if model factors have a significant impact of performance measures. Using the values from Table 6, pilot

runs of the model are conducted to see the effect on the total number of backorders and fill rate. The model is run with one replication for 365 days to achieve steady state results of the performance parameters if possible. The usage and repair rates also use different random number streams to achieve independence between runs for later experiments. After running the model, the amount of backorders is too high according to the expected results using METRIC. This is because METRIC uses expected values of the distribution while the simulation introduces variability from the distributions used in repair and demand. Since the usage rate, repair rate, and order and ship time are predetermined, the only other inputs that are adjustable are the inventory levels of the base and depot. These values are adjusted to increase the fill rate to a reasonable number and kept the same across experiments after discussion with logistics experts. Table 8 shows the adjusted input parameters for the model.

Table 8: Adjusted Model Input Parameters.

Model Inputs	Value
Depot Repair Rate	Triangle(2,3,4) days
Base Usage Rate	Exponential(2) days
Ship Time From Base to Depot	5 days
Ship Time From Depot to Base	5 days
Base Stock Level	12 items
Depot Stock Level	30 items

Step 6: Validate the programmed model.

If the model is not valid, the process begins again with defining assumptions and the conceptual model. The conceptual and computer models are valid from discussions with Air Force Logistics Officers and experts in ARENA modeling once the problems found in pilot runs were corrected.

Step 7: Design experiments.

After validation, experiments are designed and conducted. In order to minimize variance among the statistics collected, 40 replications of each experiment are run for 365 days as a starting point. The data will be collected for the baseline to see if the number of replications ran are enough to establish a confidence in the data. The following table summarizes the different scenarios modeled. The first four are operating policies and the last five are situations that could realistically occur if the forecast is incorrect or reaction to the forecast is less than capacity. The length of time the depot has to react to increase in demand was chosen arbitrarily and is just meant to show a difference in the reaction of the depot.

Table 9: Summary of Scenarios

Scenario	Base	Depot
1: No Forecast	Baseline	Baseline
2: Two Week Forecast	Increase demand for 2 weeks	Has 2 weeks to react, increase repair rate for 2 weeks
3: One Week Forecast	Increase demand for 2 weeks	Has 1 week to react, increase repair rate for 2 weeks
4: Four Week Forecast	Increase demand for 2 weeks	Has 4 weeks to react, increase repair rate for 2 weeks
5: Demand Under Forecast	Increase demand for 2 weeks but less demand than forecasted	Has 2 weeks to react, increase repair rate for 2 weeks
6: Demand Over Forecast	Increase demand for 2 weeks but more demand than forecasted	Has 2 weeks to react, increase repair rate for 2 weeks
7: No Change in Demand	No increase in demand	Has 2 weeks to react, increase repair rate for 2 weeks
8: Depot Under Repair Rate	Increase demand for 2 weeks	Has 2 weeks to react, increase repair rate less than capacity
9: No Change in Depot Repair Rate	Increase demand for 2 weeks	No increase in repair rate

Scenario 1: No forecast scenario

In the no forecast scenario the base does not share demand information with the depot. Both usage rates and repair rates do not change in a schedule for the duration of the run. The values from Table 8 are used for this scenario.

Scenario 2: Two week forecast scenario.

In this scenario the base informs the depot two weeks in advance that it will have an increase of demand for two weeks. The depot adjusts repair time accordingly to meet the needs of the base. Table 10 show the schedules used for the scenario. The depot starts with the increased repair rate for two weeks then changes to the regular repair rate for the remaining time. The two week repair rate is determined by calculating the length of time it would take to meet the nine parts the base has told the depot it needs. The base usage rate begins with the regular usage rate for two weeks, then to the increased usage rate for two weeks, and back to the regular usage rate for the remaining time.

Table 10: Two Week Forecast Rate Schedule

Model Inputs	Value (days)	Duration (days)
Depot Repair Rate	Triangle(1,1.5,2)	14
	Triangle(2,3,4)	351
Base Demand Rate	Exponential(2)	14
	Exponential(1.5)	14
	Exponential(2)	337

Scenario 3: One week forecast scenario.

This uses the same setup as scenario 2 but the base informs the depot only one week in advance that it will have an increase of demand for two weeks. The depot starts with the increased repair rate for two weeks then changes to the regular repair rate for the

remaining time. The base usage rate begins with the regular usage rate for one week, then to the increased usage rate for two weeks, and back to the regular usage rate for the remaining time. Table 11 shows the rate schedule for this scenario.

Table 11: One Week Forecast Rate Schedule

Model Inputs	Value (days)	Duration (days)
Depot Repair Rate	Triangle(1,1.5,2)	14
	Triangle(2,3,4)	351
Base Demand Rate	Exponential(2)	7
	Exponential(1.5)	14
	Exponential(2)	344

Scenario 4: Four week forecast scenario

In this scenario the base informs the depot four weeks in advance that it will have an increase of demand for two weeks. The depot starts with the increased repair rate for two weeks then changes to the regular repair rate for the remaining time. The base usage rate begins with the regular usage rate for four weeks, then to the increased usage rate for two weeks, and back to the regular usage rate for the remaining time. Table 12 shows the rate schedule for this scenario.

Table 12: Four Week Forecast Rate Schedule

Model Inputs	Value (days)	Duration (days)
Depot Repair Rate	Triangle(1,1.5,2)	14
	Triangle(2,3,4)	351
Base Demand Rate	Exponential(2)	28
	Exponential(1.5)	14
	Exponential(2)	323

Scenario 5: Demand under forecast

In this scenario the base informs the depot two weeks in advance that it will have an increase in demand for two weeks. The depots increases repair for two weeks then changes to the regular repair rate for the remaining time. The base however does not demand as much as forecasted. Table 13 shows the rate schedule for this scenario.

Table 13: Demand Under Forecast Rate Schedule

Model Inputs	Value (days)	Duration (days)
Depot Repair Rate	Triangle(1,1.5,2)	14
	Triangle(2,3,4)	351
Base Demand Rate	Exponential(2)	14
	Exponential(3)	14
	Exponential(2)	337

Scenario 6: Demand over forecast

In this scenario the base informs the depot two weeks in advance that it will have an increase in demand for two weeks. The depots increases repair for two weeks then changes to the regular repair rate for the remaining time. The base however demands more than forecasted. Table 14 shows the rate schedule for this scenario.

Table 14: Demand Over Forecast Rate Schedule

Model Inputs	Value (days)	Duration (days)
Depot Repair Rate	Triangle(1,1.5,2)	14
	Triangle(2,3,4)	351
Base Demand Rate	Exponential(2)	14
	Exponential(1)	14
	Exponential(2)	337

Scenario 7: No change in demand

In this scenario the base informs the depot two weeks in advance that it will have an increase in demand for two weeks. The depots increases repair for two weeks then changes to the regular repair rate for the remaining time. The base however never changes its demand. Table 15 shows the rate schedule for this scenario.

Table 15: No Change in Demand Rate Schedule

Model Inputs	Value (days)	Duration (days)
Depot Repair Rate	Triangle(1,1.5,2)	14
	Triangle(2,3,4)	351
Base Demand Rate	Exponential(2)	365

Scenario 8: Depot under repair rate

In this scenario the base informs the depot two weeks in advance that it will have an increase in demand for two weeks. The depots experiences difficulty in increasing its repair rate and takes longer than expected. The depot increases repair for 19 days then changes to the regular repair rate for the remaining time. The base demands items as forecasted. Table 16 shows the rate schedule for this scenario.

Table 16: Depot Under Repair Rate Schedule

Model Inputs	Value (days)	Duration (days)
Depot Repair Rate	Triangle(1,2,3)	19
	Triangle(2,3,4)	346
Base Demand Rate	Exponential(2)	14
	Exponential(1.5)	14
	Exponential(2)	337

Scenario 9: No change in depot repair rate

In this scenario the base informs the depot two weeks in advance that it will have an increase in demand for two weeks. The depots does not use the information and continues repair at its current rate. The base demands items as forecasted. Table 17 shows the rate schedule for this scenario.

Table 17: No Change in Depot Repair Rate Schedule

Model Inputs	Value (days)	Duration (days)
Depot Repair Rate	Triangle(2,3,4)	365
Base Demand Rate	Exponential(2)	14
	Exponential(1.5)	14
	Exponential(2)	337

Step 8: Make production runs.

This step is accomplished by running the scenarios mentioned above in step 7 using Arena.

Step 9: Analyze output.

Analysis is discussed in Chapter 4.

Step 10: Document, present and use results.

Conclusions and future research are presented in Chapter 5.

IV. Analysis

Classical statistical techniques based on i.i.d. (independent and identically distributed) observations are used in the analysis of the experiments ran for this thesis. A single run of a computer simulation often produce observations that are nonstationary and autocorrelated and therefore use of classical statistics are not applicable. However runs using different random numbers for each replication with statistical counters reset at the beginning of each replication result in independence across runs. Outputs to the simulation are then used to draw inferences and conclusions about the system. The first four scenarios described in Chapter 3 are considered alternative operating policies and therefore comparisons using confidence intervals for the outputs is appropriate. The last five scenarios are also compared using confidence intervals to see if the situations have any significance in fulfilling backorders. [12]

The no forecast scenario is the base case to which the alternative operating policies are compared. From the 40 repetitions made for the base case, the mean for the fill rate equals 0.812 and the standard deviation equals 0.088. A 95% confidence interval is 0.812 ± 0.0282 or between 0.7838 and 0.8402. The small interval leads one to believe 40 repetitions is sufficient for the experiments.

To achieve a 90 percent overall confidence interval that the alternative operating policies differ from the standard, the Bonferroni inequality is used. The Bonferroni inequality test states that to achieve at least an overall confidence interval of 90 percent, the individual confidence intervals of the difference in means should be constructed at $1 - 0.1/8 = 0.9875$ or 99 percent [12, p 562]. If the difference between the mean of the

“standard” or no forecast scenario and the alternative operating policies contain zero, there is no difference between the operating policies. The following tables show the results of the differences between the means of the operating policies scenarios using fill rate and backorder.

Table 18 shows paired t-test confidence intervals for fill rate while Table 19 shows paired t-test confidence intervals for backorder of the difference in means between the no forecast scenario and the eight other scenarios. Confidence interval tests instead of hypothesis testing for the difference in means are used because confidence interval tests will indicate not only if the means differ but also the magnitude by which they differ.

The following equations were used for the paired t-test confidence intervals. [12]

$$i = 2 \dots 9$$

$$j = 1 \dots 40$$

X_{1j} = Mean of the observations in the j th set of the “no forecast scenario”

Y_{ij} = Mean of the observation in the j th set of an alternative scenario i

$$W_{ij} = X_{1j} - Y_{ij}$$

$$\bar{W}_i(40) = \bar{X}(40) - \bar{Y}_i(40)$$

$$\hat{Var}[\bar{W}_i(40)] = \frac{\sum_{j=1}^{40} [W_{ij} - \bar{W}_i(40)]^2}{39}$$

99 percent confidence interval

$$\bar{W}_i(40) \pm t_{39,0.99} \sqrt{\hat{Var}[\bar{W}_i(40)]}$$

Table 18: Paired t-test for Backorder at 99% Confidence

Scenario	$W_{ij} = X_j - Y_{ij}$	$\hat{Var}[\bar{W}_i(40)]$	paired t-test		
			half-length	CI low	CI high
2: Two Week Forecast	6.9075	23.68863133	0.061394158	6.8461058	6.9688942
3: One Week Forecast	6.9075	23.68863133	0.061394158	6.8461058	6.9688942
4: Four Week Forecast	6.9075	23.68863133	0.061394158	6.8461058	6.9688942
5: Demand Under Forecast	6.9075	23.68863133	0.061394158	6.8461058	6.9688942
6: Demand Over Forecast	6.9075	23.68863133	0.061394158	6.8461058	6.9688942
7: No Change in Demand	6.9075	23.68863133	0.061394158	6.8461058	6.9688942
8: Depot Under Repair Rate	-58.7909	47.28999276	0.086744448	-58.87764	-58.70416
9: No Change in Depot Repair Rate	-58.515225	36.2595851	0.075957118	-58.59118	-58.43927

Table 19: Paired t-test for Fill Rate at 99% Confidence

Scenario	$W_{ij} = X_j - Y_{ij}$	$\hat{Var}[\bar{W}_i(40)]$	paired t-test		
			half-length	CI low	CI high
2: Two Week Forecast	-0.18298	0.007832333	0.001116	-0.18409	-0.18186
3: One Week Forecast	-0.18298	0.007832333	0.001116	-0.18409	-0.18186
4: Four Week Forecast	-0.18298	0.007832333	0.001116	-0.18409	-0.18186
5: Demand Under Forecast	-0.18298	0.007832333	0.001116	-0.18409	-0.18186
6: Demand Over Forecast	-0.18298	0.007832333	0.001116	-0.18409	-0.18186
7: No Change in Demand	-0.18298	0.007832333	0.001116	-0.18409	-0.18186
8: Depot Under Repair Rate	0.609625	0.009615266	0.001237	0.608388	0.610862
9: No Change in Depot Repair Rate	0.608675	0.008057917	0.001132	0.607543	0.609807

The results show that all the scenarios differ with respect to backorder and fill rate from the standard since zero is not included in their 99 percent confidence intervals. Looking at the means and variances of the fill rates for the Two Week Forecast, One Week Forecast, and Four Week Forecast in

Table 20 shows an almost 100% fill rate for the alternate procedures with very small variances. From this, one can infer that any forecasting policy is better than no forecast at all.

Table 20: Fill Rate Means and Variances for Operating Procedures

Scenario	Mean	Variance
1: No Forecast	0.81688	0.007775087
2: Two Week Forecast	0.99985	9E-07
3: One Week Forecast	0.99985	9E-07
4: Four Week Forecast	0.99985	9E-07

Scenarios five through nine deal with situations that could routinely occur at the base or depot echelons. Incorrect forecasting or inability to respond with an increase in repair rate are situations that could happen. In the scenarios where the depot responded at the repair rate set when responding to an increase in demand due to projected forecast, the average fill rate were close to 100% with very small variance. When the depot could not meet the repair rate or ignored the forecast altogether, the average fill rate was much lower than the standard scenario with very small variation as seen in Table 21.

Table 21: Fill Rate for Means and Variances for Alternate Scenarios

Scenario	Mean	Variance
5: Demand Under Forecast	0.99985	9E-07
6: Demand Over Forecast	0.99985	9E-07
7: No Change in Demand	0.99985	9E-07
8: Depot Under Repair Rate	0.20725	0.000613423
9: No Change in Depot Repair Rate	0.2082	0.000715395

V. Discussion, Conclusions and Recommendations

The analysis demonstrated differences between using a forecast and not having one at all. In the case where the base presented the depot with a forecast and the depot responded by increasing its repair rate, the amount of backorders decreased and the fill rates increased when compared to the no forecast model. As expected when the depot increased its repair rate and the base did not increase its demand as much as forecasted, the number of backorders decreased and the fill rate increased since the depot repaired at a higher rate but demand stayed the same. When the base demanded more than forecasted, the number of backorders increased and the fill rate decreased.

The Air Force should continue to use demand forecasts to schedule repair at depot levels. They should be as accurate as possible since incorrect information has an affect on the fill rate from the depot. The forecast should not just be a yearly average but should incorporate demand information anticipated when exercises or periods of increased use are projected. As seen in the analysis, any forehand knowledge is better than not having any at all. With at least a bi-monthly forecast the depots have a chance of meeting the demand requirements from bases.

Suggestions for Further Study

Recommendations for further study include expanding the ARENA model to include multiple bases and depots to see interaction between them as well as real fail and repair data on more parts. The level of complexity could be increased by having the bases and depots demanding and repairing at different rates at different times of the year.

This could lead to an optimization of the number of depot repair stations required for specific parts.

Another area for research would be to determine the “best” forecast procedure for various parts, for example, would a single forecast procedure work for all parts or would several procedures need to be implemented depending on the part and circumstances. Adding prioritization for repair is another avenue to study.

The model could also be expanded for use in “what if” scenarios. For example, what would happen to the supply pipeline if depot X were destroyed, which depots could pick up the work load and how would the fill rate and backorders be affected? Real demand forecast from bases should also be incorporated into the model. Exploration of the length of time the forecast is for and the lead time in which the forecast is given should be explored to see if those scenarios matter.

Appendix A: ARENA Code

```
;
;
;Model statements for module:    Create 3
;
73$ CREATE,      30,HoursToBaseTime(0.0) ,Blank Part: HoursToBaseTime(EXPO(1)),
1:NEXT(74$);

74$ ASSIGN:      Create Initial Depot Supply.NumberOut=Create Initial Depot Supply.NumberOut+1:
NEXT(27$);
;
;
;Model statements for module:    Assign 8
27$ ASSIGN:      Product Cost=Product Cost + 43755.6:
Picture=Picture.Box:
Base=1:NEXT(19$);
;
;Model statements for module:    Match 2
16$ QUEUE,      Match Parts with Request.Queue1:DETACH;
19$ QUEUE,      Match Parts with Request.Queue2:DETACH;
MATCH:          16$,26$
                19$,26$
;
;
;Model statements for module:    Batch 2
26$ QUEUE,      Places Order and Part Together for Delivery,Queue;
77$ GROUP,      ,Permanent:2,Product:NEXT(78$);

78$ ASSIGN:      Places Order and Part Together for Delivery.NumberOut= Places Order and Part
Together for Delivery.NumberOut+1:NEXT(29$);
;
;
;Model statements for module:    Separate 2
29$ DUPLICATE,  100 - 0:
                1,81$,0:NEXT(80$);

80$ ASSIGN:      Send Replacement Request to Depot Maintenance.NumberOut Orig=Send
Replacement Request to Depot Maintenance.NumberOut Orig +1:NEXT(12$);

81$ ASSIGN:      Send Replacement Request to Depot Maintenance.NumberOut Dup=Send
Replacement Request to Depot Maintenance.NumberOut Dup +1:NEXT(31$);
;
;
;Model statements for module:    Assign 6
12$ ASSIGN:      Transportation Cost=Transportation Cost + 3.91:
Picture=Picture.Green Ball:NEXT(34$);
;
;
;Model statements for module:    Record 1
34$ COUNT:      SJ Standard Counter,1:NEXT(14$);
;
;
;Model statements for module:    Route 1
```

```

14$ ROUTE:      5.000000000000000,Seymour Johnson AFB;
;
;
;Model statements for module:   Assign 13
31$ ASSIGN:     Entity.Type=Depot Order:
                Picture=Picture.Report:
                Base=1:NEXT(30$);
;
;
;Model statements for module:   Route 3
30$ ROUTE:     0.000000000000000,Depot Maintenance;
;
;
;Model statements for module:   Station 1
13$ STATION,   Seymour Johnson AFB;
84$ DELAY:    0.0,,VA:NEXT(36$);
;
;
;Model statements for module:   Match 3
36$ QUEUE,    Seymour Johnson Supply.Queue1:DETACH;
39$ QUEUE,    Seymour Johnson Supply.Queue2:DETACH;
    MATCH:    36$,41$:
                39$,41$;
;
;
;Model statements for module:   Batch 3
41$ QUEUE,    Batch 3.Queue;
85$ GROUP,    ,Permanent:2,Last:NEXT(86$);

86$ ASSIGN:    Batch 3.NumberOut= Batch 3.NumberOut + 1:NEXT(23$);
;
;
;Model statements for module:   Separate 1
23$ DUPLICATE, 100 - 0:
                1,89$,0:NEXT(88$);

88$ ASSIGN:    Send Seymour Johnson Order to Depot.NumberOut Orig=Send Replacement Send
Seymour Johnson Order to Depot.NumberOut Orig +1:NEXT(21$);

89$ ASSIGN:    Send Seymour Johnson Order to Depot.NumberOut Dup=Send Replacement Send
Seymour Johnson Order to Depot.NumberOut Dup +1:NEXT(24$);
;
;
;Model statements for module:   Process 3
21$ ASSIGN:    SJ Use 1.NumberIn= SJ Use 1.NumberIn + 1:
                SJ Use 1.WIP= SJ Use 1.WIP + 1;
119$ STACK,    1:Save:NEXT(91$);

91$ DELAY:    HoursToBaseTime(EXPO(48)),,VA:NEXT(100$);

100$ TALLY:    SJ Use 1.TotalTimePerEntity,Diff.StartTime,1;
124$ ASSIGN:    SJ Use 1.VATime= SJ Use 1.VATime + Diff.VATime;
125$ TALLY:    SJ Use 1.VATimePerEntity,Diff.VATime,1;
139$ STACK,    1:Destroy:NEXT(138$);

```

```

138$ ASSIGN:      SJ Use 1.NumberOut= SJ Use 1.NumberOut + 1:
                  SJ Use 1.WIP= SJ Use 1.WIP - 1:NEXT(42$);
;
;
;Model statements for module:      Separate 3
42$ DUPLICATE,   100 - 50:
                  1,143$,50:NEXT(142$);

142$ ASSIGN:      Separate 3.NumberOut Orig= Separate 3.NumberOut Orig + 1:NEXT(32$);

143$ ASSIGN:      Separate 3.NumberOut Dup= Separate 3.NumberOut Dup + 1:NEXT(39$);
;
;
;Model statements for module:      Assign 14
32$ ASSIGN:      Picture=Picture.Truck:
                  Transportation Cost= Transportation Cost + 4.36:NEXT(35$);
;
;
;Model statements for module:      Record 2
35$ COUNT:      SJ Standard Retro Count,1:NEXT(33$);
;
;
;Model statements for module:      Route 4
33$ ROUTE:      5.000000000000000,Depot Maintenance;
;
;
;Model statements for module:      Assign 7
24$ ASSIGN:      Picture=Picture.Report:
                  Entity.Type=Order:
                  Base=4:NEXT(25$);
;
;
;Model statements for module:      Route 2
25$ ROUTE:      0.000000000000000,Depot Supply;
;
;
;Model statements for module:      Station 2
15$ STATION,    Depot Supply;
146$ DELAY:    0.0,,VANEXT(16$);
;
;
;Model statements for module:      Create 4
147$ CREATE,    12,HoursToBaseTime(0.0),Seymour Johnson Part: HoursToBaseTime (EXPO(1)),1:
NEXT(148$)

148$ ASSIGN:    Create SJ Initial Supply.Number Out= Create SJ Initial Supply.Number Out + 1:
NEXT(28$)
;
;
;Model statements for module:      Assign 9
28$ ASSIGN:    Picture=Picture.Green Ball:
                  Product Cost=Product Cost + 43755.6:NEXT(36$);
;
;

```

```

;Model statements for module:    Station 3
22$ STATION,    Depot Maintenance;
153$ DELAY:    0.0,,VA:NEXT(0$);
;
;
;Model statements for module:    Process 1
0$ ASSIGN:    Depot Maintenance.NumberIn= Depot Maintenance.NumberIn + 1:
    Depot Maintenance.WIP= Depot Maintenance.WIP + 1:

183$ STACK,    1,Save:NEXT(3$);

3$ BRANCH,    1:
    If,Entity.Type==Depot Order,205$,Yes:
    Else,206$,Yes;
205$ ASSIGN:    Part or Order?.NumberOut True=Part or Order?.NumberOut True+ 1:NEXT(4$);
206$ ASSIGN:    Part or Order?.NumberOut False=Part or Order?.NumberOut False+ 1:NEXT(7$);

4$ QUEUE,    Induction of Parts for Repair.Queue1:DETACH;
7$ QUEUE,    Induction of Parts for Repair.Queue2:DETACH;
MATCH:    4$,9$:
    7$,9$;
9$ QUEUE,    Batch 1.Queue;
207$ GROUP,    ,Permanent:2,Last:NEXT(208$);

208$ ASSIGN:    Batch 1.NumberOut= Batch 1.NumberOut + 1:NEXT(10$);

10$ QUEUE,    Repair.Queue;
SCAN:    Repair.WIP == 0:NEXT(1$);

1$ ASSIGN:    Repair.NumberIn= Repair.NumberIn + 1:
    Repair.WIP=Repair.WIP+1;
238$ STACK,    1:Save:Next(210$);

210$ DELAY:    HoursToBaseTime(SchedValue(Depot Repair)),,Wait:NEXT(253$);

253$ ASSIGN:    Repair.WaitTime=Repair.WaitTime + Diff.WaitTime;
217$ TALLY:    Repair.WaitTimePerEntity,Diff.WaitTime,1;
219$ TALLY:    Repair.WaitTimePerEntity,Diff.StartTime,1;
258$ STACK,    1:Destroy:NEXT(257$);

257$ ASSIGN:    Repair.NumberOut=Repair.NumberOut + 1
    Repair.WIP=Repair.WIP-1:NEXT(2$);

2$ ASSIGN:    Repair Cost=Repair Cost + 6687:
    Base=1:
    Picture=Picture.Box:NEXT(170$);

170$ TALLY:    Depot Maintenance.WaitTimePerEntity,Diff.WaitTime,1;
172$ TALLY:    Depot Maintenance.VATimePerEntity,Diff.VATime,1;
174$ TALLY:    Depot Maintenance.NVATimePerEntity,Diff.NVATime,1;
179$ TALLY:    Depot Maintenance.TranTimePerEntity,Diff.TranTime,1;
181$ TALLY:    Depot Maintenance.OtherTimePerEntity,Diff.OtherTime,1;
176$ TALLY:    Depot Maintenance.TotalTimePerEntity,Diff.StartTime,1;

```

```

195$ ASSIGN:      Depot Maintenance.VATime=Depot Maintenance.VATime + Diff.VATime:
                  Depot Maintenance.NVATime=Depot Maintenance.NVATime + Diff.NVATime:
                  Depot Maintenance.TranTime=Depot Maintenance.TranTime + Diff.TranTime:
                  Depot Maintenance.OtherTime=Depot Maintenance.OtherTime + Diff.OtherTime:
                  Depot Maintenance.WaitTime=Depot Maintenance.WaitTime + Diff.WaitTime;
203$ STACK,      1:Destroy:NECT(202$);

202$ ASSIGN:      Depot Maintenance.NumberOut= Depot Maintenance.NumberOut + 1:
                  Depot Maintenance.WIP= Depot Maintenance.WIP-1:NEXT(19$);
;
;
;
;Model statements for module:      Create 10
260$ CREATE,      1,HoursToBaseTime(0.0),Initial Demand:HoursToBaseTime(EXPO(1)),1:
NEXT(261$);

261$ ASSIGN:      Create SJ Initial Demand.NumberOut= Create SJ Initial Demand.NumberOut +1:
NEXT(39$);
;
;
;
;Model statements for module:      Create 1
264$ CREATE,      1,MinutesToBaseTime(0.0),Entity 1:MinutesToBaseTime(1440):NEXT(265$);

265$ ASSIGN:      Create Counter Entity.NumberOut= Create Counter Entity.NumberOut + 1:
NEXT(43$);
;
;
;
;Model statements for module:      Assign 1
43$ ASSIGN:      Time Of Day=0:NEXT(44$);
;
;
;
;Model statements for module:      Assign 2
44$ ASSIGN:      Time Of Day=Time of Day + 1:NEXT(45$);
;
;
;
;Model statements for module:      Decide 1
45$ BRANCH,      1:
                  If,Time Of Day<48,258$,Yes:
                  Else, 269$,Yes;
268$ ASSIGN:      Check Period.NumberOut True= Check Period.NumberOut True + 1: NEXT(46$);

269$ ASSIGN:      Check Period.NumberOut False= Check Period.NumberOut False + 1: NEXT(47$);
;
;
;
;Model statements for module:      Delay 1
46$ DELAY:      0.0208333333333333,,Other:NEXT(44$);
;
;
;
;Model statements for module:      Dispose 1
47$ ASSIGN:      Dispose of Counter Entity.NumberOut=Dispose of Counter Entity.NumberOut + 1;
270$ DISPOSE:      Yes;
;
;
;
;Model statements for module:      Create 2
271$ CREATE,      1,HoursToBaseTime(0.0),Day Counter:HoursToBaseTime(168):NEXT(272$);

```

```

272$ ASSIGN:      Create Day Counter Entity.NumberOut= Create Day Counter Entity.NumberOut + 1:
NEXT(48$);
;
;
;Model statements for module:      Assign 3
48$ ASSIGN:      Day=0:NEXT(49$);
;
;
;Model statements for module:      Assign 4
49$ ASSIGN:      Day=Day + 1: NEXT(50$);
;
;
;Model statements for module:      Decide 2
50$ BRANCH,      1:
                  If,Time Of Day<7,275$,Yes:
                  Else, 276$,Yes;
275$ ASSIGN:      Check Day.NumberOut True= Check Day.NumberOut True + 1: NEXT(51$);

276$ ASSIGN:      Check Day.NumberOut False= Check Day.NumberOut False + 1: NEXT(52$);
;
;
;Model statements for module:      Delay 2
51$ DELAY:      1.0000000000000000,, Other:NEXT(49$);
;
;
;Model statements for module:      Create 5
278$ CREATE,      1,HoursToBaseTime(0.1),Seymour Johnson Backorder
Counter:HoursToBaseTime(EXPO(1)),1:NEXT(279$);

279$ ASSIGN      Create Seymour Johnson Backorder Counter.NumberOut= Create Seymour Johnson
Backorder Counter.NumberOut + 1:NEXT(53$);
;
;
;Model statements for module:      Assign 10
53$ ASSIGN:      Seymour Johnson Backorder= 0:NEXT(55$);
;
;
;Model statements for module:      Hold 2
55$ QUEUE,      Hold 2.Queue;
SCAN:          NQ(Seymour Johnson Supply.Queue2) > NQ(Seymour Johnson Supply.Queue1):
NEXT(54$);
;
;
;Model statements for module:      Assign 11
54$ ASSIGN      Seymour Johnson Backorder= Seymour Johnson Backorder + 1:NEXT(57$);
;
;
;Model statements for module:      Hold 3
57$ QUEUE,      Hold 3.Queue;
SCAN:          SJ Use1.WIP ==1:NEXT(55$);
;
;
;Model statements for module:      Create 6

```

```

282$ CREATE,      1,HoursToBaseTime(tfin),Seymour Johnson fill rate calc:
HoursToBaseTime(EXPO(1)),1:NEXT(283$);

283$ ASSIGN:      Create 6.NumberOut=Create 6.NumberOut + 1:NEXT(59$);
;
;
;Model statements for module:      Assign 12
59$ ASSIGN:      Seymour Johnson Stockage Effectiveness=(SJ USE1.NumberIn-Seymour Johnson
Backorder )/ (SJ Use1.NumberIn):NEXT(60$);
;
;
;Model statements for module:      Dispose 3
60$ ASSIGN:      Dispose 3.NumberOut=Dispose 3.NumberOut + 1;
268$ DISPOSE:    Yes;
;
;
;Model statements for module:      Create 11
287$ CREATE,      1,HoursToBaseTime(0.1),SJ Surplus Counter:HoursToBaseTime(EXPO(1)),1:
NEXT(288$);

288$ ASSIGN:      Create SJ Surplus Counter.NumberOut= Create SJ Surplus Counter.NumberOut + 1:
NEXT(61$);
;
;
;Model statements for module:      Assign 18
61$ ASSIGN:      SJ Surplus=0:NEXT(62$);
;
;
;Model statements for module:      Hold 4
62$ QUEUE,      Hold 4.Queue;
SCAN:           NQ(Seymour Johnson Supply.Queue1)> NQ(Seymour Johnson Supply.Queue2):
NEXT(64$);
;
;
;Model statements for module:      Assign 19
64$ ASSIGN:      SJ Surplus=SJ Surplus + 1:NEXT(65$);
;
;
;Model statements for module:      Hold 5
65$ QUEUE,      Hold 5.Queue;
SCAN:           SJ Use 1.WIP == 0: NEXT(64$);
;
;
;Model statements for module:      Create 7
291$ CREATE,      1,HoursToBaseTime(tfin),Entity 1:HoursToBaseTime(EXPO(1)),1: NEXT(292$);

288$ ASSIGN:      Create 7.NumberOut= Create 7.NumberOut + 1: NEXT(67$);
;
;
;Model statements for module:      Assign 15
67$ ASSIGN:      depot maintenance holding cost=DAVG(Repair.Queue.NumberInQueue)*.12*
43755.6*6:NEXT(68$);
;
;
;

```

```

;Model statements for module:    Dispose 4
68$ ASSIGN:    Dispose 4.NumberOut=Dispose 4.NumberOut + 1;
295$ DISPOSE:    Yes;
;
;
;Model statements for module:    Create 8
296$ CREATE,    1,HoursToBaseTime(SJ Use 1.NumberIn==600),Entity
1:HoursToBaseTime(EXPO(1)),1: NEXT(297$);

297$ ASSIGN:    Create 8.NumberOut= Create 8.NumberOut + 1: NEXT(69$);
;
;
;Model statements for module:    Assign 16
69$ ASSIGN:    depot supply holding cost=DVAG(Match Parts with
Request.Queue2.NumberInQueue)*.12*43755.60*6
: NEXT(70$);
;
;
;Model statements for module:    Dispose 5
70$ ASSIGN:    Dispose 5.NumberOut=Dispose 5.NumberOut + 1;
300$ DISPOSE:    Yes;
;
;
;Model statements for module:    Create 9
301$ CREATE,    1,HoursToBaseTime(tfin),Entity 1:HoursToBaseTime(EXPO(1)),1: NEXT(302$);

302$ ASSIGN:    Create 9.NumberOut= Create 9.NumberOut + 1: NEXT(71$);
;
;
;Model statements for module:    Assign 17
71$ ASSIGN:    Seymour Johnson Holding Cost=DVAG(Seymour Johnson
Supply.Queue1.NumberInQueue)*.12*43755.60*6
: NEXT(72$);
;
;
;Model statements for module:    Dispose 6
72$ ASSIGN:    Dispose 6.NumberOut=Dispose 6.NumberOut + 1;
305$ DISPOSE:    Yes;

```

Appendix B: Definition of Terms

AAM: Aircraft Availability Model
ACS: Agile Combat Support
AFB: Air Force Base
CPFR: Collaborative Planning, Forecasting and Replenishment
EXPRESS: Execution and Prioritization of Repair Support System
LMI: Logistics Management Institute
METRIC: Multi-Echelon Technique for Recoverable Item Control
NRTS: Not Repairable This Station
P&G: Proctor & Gamble
REALM: Requirements Execution Availability Logistics Module
RBL: Readiness Based Levels
SBSS: Standard Base Supply System
Vari-METRIC:
VICS: Voluntary Interindustry Commerce Standards

Bibliography

1. AFLMA, Air Force Logistics Management Agency, *Logistics Dimension 2003: Strategy, Issues, and Analyses*. 2003, USAF.
2. AFMC, Air Force Material Command, *EXPRESS VERSION 5.0 OVERVIEW*. 2003. p. 2.2-2-17. <https://www.express.day.disa.mil/>
3. Bowersox, Donald J. and Closs, David. J., *Simulation in Logistics: A Review Of Present Practice And A Look To The Future*. Journal of Business Logistics, 1989. **10**(1): p. 133.
4. Chen, Frank, et al., *Quantifying the Bullwhip Effect in a Simple Supply Chain: The Impact of Forecasting, Lead Times, and Information*. INFORMS, 2000. **46**(3): p. 436-443.
5. Christopher, Martin, *An integrated model for the design of agile supply chains*. International Journal of Physical Distribution & Logistics Management, 2001. **31**(4): p. 235-246.
6. Cooke, James Aaron, *Why Ace is becoming the place: Forget the helpful hardware man. Ace in the 21st century wants to be the place with the flourishing CPFR programs*. Logistics Management & Distribution Report, 2002. **41**(3): p. 32-36.
7. Eilers, Jim, Maj, *EXPRESS: EXecution and Prioritization of REpair Support System*, HQ AFMC/LGIP.
8. Gray, Steve, Capt, *Bullet Background Paper on Switching From Flying Hours To Daily Demand Rate (DDR) in EXPRESS*. 2001, HQ ACC/LGS. p. 1-3.
9. Hicks, Donald A., *The Manager's Guide to Supply Chain and Logistics Problem*. IIE, 1997. **29**: p. 43-47.
10. Kelton, W. David, Sadowski, Randall P., and Sadowski, Deborah A., *Simulation With Arena*. 2nd ed. 2002, New York: McGraw-Hill.

11. Kopazak, Laura R. and Johnson, M. Eric, *The supply-chain management effect*. MIT Sloan Management Review, 2003. **44**(3): p. 27-35.
12. Law, Averill M. and Kelton, W. David, *Simulation Modeling and Analysis*. 3rd ed. 2000, New York: McGraw-Hill.
13. Lee, Hau L., Padmanabhan, V., and Whang, Seungjin, *The bullwhip effect in supply chains*. Sloan Management Review, 1997. **38**(3): p. 93-103.
14. Lewis, Len, *CPFR Solutions*. Progressive Grocer, 2000. **79**(4): p. 28.
15. LMI, Logistics Management Institute, *The Evolution of the Air Force Requirements Computation*. 2000, LMI.
16. Maxwell, Melvin, Capt, *A Performance Evaluation of a Lean Repairable Pipeline in Various Demand Environments*, in *ENS/GLM*. 2004, Air Force Institute of Technology: Dayton. p. 127.
17. McKaige, Walter, *Collaborating on the supply chain*. IIE, 2001. **33**(3): p. 34.
18. Ravindran, A., Phillips, Don T., and Solberg, James J., *Operations Research Principles and Practice*. 1987, John Wiley & Sons, Inc.: New York City. p. 7-11.
19. Riddalls, C.E., Bennett, S., and Tipi, N.S., *Modelling the dynamics of supply chains*. International Journal of Systems Science, 2000. **31**(8): p. 969-976.
20. Riddleberger, Eric, et al., *Mobile Device Returns and Repairs: Reshaping the Reverse Supply Chain*. 2002, Booz Allen Hamilton, Inc.
21. Rockwell-Automation, *Arena-Forward Visibility for Your Business*. 2000, Rockwell Software. p. 1-20. www.arenasimulation.com/pdf/ArenaWhitePaper.pdf
22. Sherbrooke, Craig C., *Optimal Inventory Modeling of Systems*. 1992, New York: John Wiley & Sons, Inc.

23. Simchi-Levi, David, Kaminsky, Phillip, and Simchi-Levi, Edith, *Designing and Managing the Supply Chain: Concepts, Strategies, and Case Studies*. 2nd ed. 2003, New York: McGraw-Hill/Irwin.
24. Syncra, *The Next Wave of Supply Chain Advantage: Collaborative Planning, Forecasting and Replenishment*, in *CPFR Survey Findings & Analysis*. 2000, Industry Direction Inc. Syncra Systems Inc.
25. USAF, *Joint Functional Concepts, Focused Logistics Coordination Draft*. 2003, USAF. http://www.dtic.mil/jointvision/focused_logistics.pdf
26. USAF/ILMM, *Air Force Weapon System Repairable Asset Management*, in *Logistics*. 1998, HQ USAF/ILMM.
27. VICS, Voluntary Interindustry Commerce Standards, *Collaborative Planning, Forecasting, and Replenishment Voluntary Guidelines*. 1998.
28. Zettler, Mike, Lt Gen, *Agile Combat Support (ACS) Overview*. 2003, AF/IL. <https://www.acs.hq.af.mil>

REPORT DOCUMENTATION PAGE

Form Approved
OMB No. 074-0188

The public reporting burden for this collection of information is estimated to average 1 hour per response, including the time for reviewing instructions, searching existing data sources, gathering and maintaining the data needed, and completing and reviewing the collection of information. Send comments regarding this burden estimate or any other aspect of the collection of information, including suggestions for reducing this burden to Department of Defense, Washington Headquarters Services, Directorate for Information Operations and Reports (0704-0188), 1215 Jefferson Davis Highway, Suite 1204, Arlington, VA 22202-4302. Respondents should be aware that notwithstanding any other provision of law, no person shall be subject to a penalty for failing to comply with a collection of information if it does not display a currently valid OMB control number.

PLEASE DO NOT RETURN YOUR FORM TO THE ABOVE ADDRESS.

1. REPORT DATE (DD-MM-YYYY) 08-06-2006	2. REPORT TYPE Master's Thesis	3. DATES COVERED (From - To) Nov 2003 - Apr 2004
--	---	--

4. TITLE AND SUBTITLE MODELING A REPARABLE SUPPLY CHAIN AND APPLYING CPFR CONCEPTS	5a. CONTRACT NUMBER
	5b. GRANT NUMBER
	5c. PROGRAM ELEMENT NUMBER

6. AUTHOR(S) Mayhall, Sandra A., Captain, USAF	5d. PROJECT NUMBER
	5e. TASK NUMBER
	5f. WORK UNIT NUMBER

7. PERFORMING ORGANIZATION NAMES(S) AND ADDRESS(S) Air Force Institute of Technology Graduate School of Engineering and Management (AFIT/EN) 2950 Hobson Way, Building 642 WPAFB OH 45433-7765	8. PERFORMING ORGANIZATION REPORT NUMBER AFIT/GOR/ENS/06-22
---	---

9. SPONSORING/MONITORING AGENCY NAME(S) AND ADDRESS(ES)	10. SPONSOR/MONITOR'S ACRONYM(S)
	11. SPONSOR/MONITOR'S REPORT NUMBER(S)

12. DISTRIBUTION/AVAILABILITY STATEMENT

APPROVED FOR PUBLIC RELEASE; DISTRIBUTION UNLIMITED.

13. SUPPLEMENTARY NOTES

14. ABSTRACT
The Air Force supply chain includes parts required to build, fix, or maintain aircraft delivered to the warfighter to carry out missions. Industry has shown that following Collaborative Planning, Forecasting and Replenishment (CPFR) concepts, in particular reducing inventory through accurate demand forecasts, has increased profits in part by lowering holding costs of inventory and increasing sales. This is analogous to the Air Force increasing aircraft availability. There is scant evidence that demand forecasts generated at any level in the Air Force are shared with the intent of coordinating replenishment.

This thesis uses a simple discrete-event stochastic simulation model to show the flow of demand information and parts moving from base and depot to see effects on the pipeline and backorders. Simulated flying hour schedules are used as future demand forecasts.

15. SUBJECT TERMS
Collaborative Planning, Forecasting and Replenishment, CPFR, Supply Chain, METRIC, Air Force Reparable Supply Chain, Depot Repair and Supply

16. SECURITY CLASSIFICATION OF:			17. LIMITATION OF ABSTRACT UU	18. NUMBER OF PAGES 68	19a. NAME OF RESPONSIBLE PERSON William A. Cunningham, PhD, AFIT/ENS
a. REPORT U	b. ABSTRACT U	c. THIS PAGE U			19b. TELEPHONE NUMBER (Include area code) 937-255-6565 x4283; e-mail: William.cunningham@afit.edu

Standard Form 298 (Rev. 8-98)
Prescribed by ANSI Std. Z39-18