

Air Force Institute of Technology

**AFIT Scholar**

---

Theses and Dissertations

Student Graduate Works

---

3-26-2006

## Reliability of Systems Using Event Occurrence Networks

Gregory M. Steeger

Follow this and additional works at: <https://scholar.afit.edu/etd>



Part of the [Operations Research, Systems Engineering and Industrial Engineering Commons](#)

---

### Recommended Citation

Steeger, Gregory M., "Reliability of Systems Using Event Occurrence Networks" (2006). *Theses and Dissertations*. 3445.

<https://scholar.afit.edu/etd/3445>

This Thesis is brought to you for free and open access by the Student Graduate Works at AFIT Scholar. It has been accepted for inclusion in Theses and Dissertations by an authorized administrator of AFIT Scholar. For more information, please contact [richard.mansfield@afit.edu](mailto:richard.mansfield@afit.edu).



RELIABILITY OF SYSTEMS  
USING  
EVENT OCCURRENCE NETWORKS

THESIS

Gregory M. Steeger, Captain, USAF

AFIT/GOR/ENS/06-17

DEPARTMENT OF THE AIR FORCE  
AIR UNIVERSITY

**AIR FORCE INSTITUTE OF TECHNOLOGY**

Wright-Patterson Air Force Base, Ohio

APPROVED FOR PUBLIC RELEASE; DISTRIBUTION UNLIMITED.

The views expressed in this thesis are those of the author and do not reflect the official policy or position of the United States Air Force, Department of Defense, or the United States Government.

AFIT/GOR/ENS/06-17

RELIABILITY OF SYSTEMS  
USING  
EVENT OCCURRENCE NETWORKS

THESIS

Presented to the Faculty  
Department of Operational Research  
Graduate School of Engineering and Management  
Air Force Institute of Technology  
Air University  
Air Education and Training Command  
In Partial Fulfillment of the Requirements for the  
Degree of Master of Science in Operations Research

Gregory M. Steeger, BS  
Captain, USAF

March 2006

APPROVED FOR PUBLIC RELEASE; DISTRIBUTION UNLIMITED.

RELIABILITY OF SYSTEMS  
USING  
EVENT OCCURRENCE NETWORKS

Gregory M. Steeger, BS  
Captain, USAF

Approved:

/signed/

21 Mar 2006

---

Lt Col David Denhard, PhD (Chairman)

---

date

/signed/

21 Mar 2006

---

Maj Robert Neher (Reader)

---

date

*Abstract*

The study of a system's reliability has played a crucial role in business and industry since the dawn of modern technology. Current graphical models utilized in reliability theory are limited in that no one model or technique allows for a thorough analysis of system reliability. This research introduces a new graphical model and methodology to be used in the field of reliability that addresses this concern. Event Occurrence Networks (EONs) and their solution methodologies provide an all-inclusive graphical model that allows for the manipulation of several important reliability measures. An EON is a probabilistic network that represents the superposition of several terminating counting processes and is an efficient tool in both non-repairable and repairable systems. Current methodologies are also restricted in the distributions that characterize component life and repair times. This concern is alleviated via EONs coupled with piecewise polynomial approximation.

## *Acknowledgements*

First and foremost, I want to thank my wife, to whom I owe a large debt of gratitude. She's my motivation and the love of my life. Without her loving support I would not be where I am today. Second, I want to thank my daughter, who's bright smile makes all the stresses of life disappear the moment I step through the door.

Gregory M. Steeger

## *Table of Contents*

	Page
Abstract . . . . .	iv
Acknowledgements . . . . .	v
List of Figures . . . . .	ix
List of Tables . . . . .	x
List of Abbreviations . . . . .	xi
I. Introduction . . . . .	1
1.1 Background . . . . .	1
1.2 Current Methods . . . . .	4
1.3 Current Method Limitations . . . . .	7
1.4 Problem Approach . . . . .	9
1.5 Research Scope . . . . .	11
1.6 Overview . . . . .	12
II. Literature Review . . . . .	13
2.1 Overview of Event Occurrence Networks and Reliability Theory . . . . .	13
2.2 EON Introduction . . . . .	13
2.3 Description [12] . . . . .	13
2.4 EON Solution Techniques . . . . .	16
2.5 Underlying Probabilistic Model . . . . .	19
2.6 Piecewise Polynomial Approximation [12] . . . . .	20
2.7 Node Explosion Problem and Bucket Analysis . . . . .	21
2.8 Reliability Theory Introduction . . . . .	22
2.9 Coherent System Analysis . . . . .	22
2.10 Lifetime Distributions . . . . .	30
2.11 Repairable Systems . . . . .	32
2.12 Summary of EON and Reliability Theory Literature . . . . .	37
III. EONs and Reliability Theory . . . . .	38
3.1 Methodology Overview for Non-Repairable Systems . . . . .	38
3.2 Methodology . . . . .	38
3.2.1 Proof . . . . .	40
3.2.2 Algorithm . . . . .	43

	Page
3.2.3 Other Measures . . . . .	44
3.3 Reliability of Simple Two Component Systems . . . . .	45
3.3.1 Series System . . . . .	45
3.3.2 Parallel System . . . . .	49
3.4 Non-Repairable Systems Methodology Summary . . . . .	50
IV. EONs and Availability . . . . .	51
4.1 Methodology Overview for Repairable Systems . . . . .	51
4.2 Methodology . . . . .	51
4.2.1 Availability of a Simple One Component System	53
4.2.2 Availability of Three Component Systems . . . .	57
4.3 Methodology with Fewer Simplifying Assumptions . . . . .	63
4.4 Repairable Systems Methodology Summary . . . . .	68
V. Illustrations and Results . . . . .	69
5.1 Implementation Overview . . . . .	69
5.2 Reliability of Systems with Non-Repairable Components	69
5.2.1 Reliability of Simple Three Component Series and Parallel Combination System . . . . .	69
5.2.2 Reliability of a Complex System . . . . .	75
5.3 Reliability of Systems with Repairable Components . . . .	86
5.3.1 Instantaneous Availability of a 2 Component Se- ries System . . . . .	86
5.4 Illustration Summary . . . . .	91
VI. Conclusion . . . . .	93
6.1 Overview . . . . .	93
6.2 Background and Literature Conclusions . . . . .	93
6.3 Methodology Conclusions . . . . .	95
6.4 Future Research Opportunities . . . . .	98
6.5 Final Recommendations . . . . .	99
Appendix A. Instantaneous Availability via CTMC's and Laplace Trans- forms . . . . .	101
Appendix B. Matlab <sup>®</sup> Code for Obtaining all of the Path and Cut Vec- tors for a Coherent System . . . . .	103
Appendix C. Nodal Probabilities for Complex EON . . . . .	104
Appendix D. Nodal Probabilities for Availability Graph with 2 Compo- nents in Series . . . . .	117

	Page
Bibliography . . . . .	127
Glossary . . . . .	131

*List of Figures*

Figure		Page
1	Example EON . . . . .	9
2	Simple EON . . . . .	15
3	RBD of 3 Components in Series . . . . .	24
4	RBD of 3 Components in Parallel . . . . .	25
5	Transition Diagram for Alternating Renewal Process . . . . .	35
6	EON of 2 Components in Series . . . . .	46
7	EON of 2 Components in Parallel . . . . .	49
8	EON of System With One Repairable Component . . . . .	54
9	Actual vs. Estimated Instantaneous Availability via EON . . . . .	56
10	Actual vs. Estimated Average Availability via Raptor . . . . .	57
11	Availability Graph for 3 Repairable Components in Series . . . . .	58
12	Actual vs. Estimated Instantaneous Availability via EON for Series System . . . . .	60
13	Availability Graph for 3 Repairable Components in Parallel . . . . .	62
14	Actual vs. Estimated Instantaneous Availability via EON for Parallel System . . . . .	63
15	Availability Graph for a Repairable Component (One Repair) . . . . .	64
16	Availability Graph for 2 Repairable Components in Series (One Repair) . . . . .	67
17	RBD of System with Components in Series and Parallel . . . . .	70
18	EON of System with Components in Series and Parallel . . . . .	70
19	FT of System with Components in Series and Parallel . . . . .	74
20	RBD of Complex System . . . . .	76
21	EON of Complex System . . . . .	76
22	Availability Graph for 2 Repairable Components in Series (One Repair) . . . . .	87
23	Nodal Probabilities for 2 Component Series Availability Graph . . . . .	88

*List of Tables*

Table		Page
1	Actual vs. Estimated Instantaneous Availability via EONs . . .	55
2	Actual vs. Estimated Average Availability via Raptor . . . . .	56
3	Actual Availability for 3 Component Series System . . . . .	59
4	Estimated Availability for 3 Component Series System Using EON	60
5	Errors for Series System Availability . . . . .	60
6	Actual Availability for 3 Component Parallel System . . . . .	61
7	Estimated Availability for 3 Component Parallel System Using EON . . . . .	62
8	Errors for Parallel System Availability . . . . .	62
9	Nodes with Associated Event Streams . . . . .	77
10	Limiting Probabilities for Absorbing Nodes in Complex EON .	85
11	Nodal Probabilities - 2 Component Series Availability Graph .	88
12	Nodal Probabilities - 2 Component Series Availability Graph .	89
13	Availability Measures - 2 Component Series Availability Graph	90

*List of Abbreviations*

Abbreviation		Page
MTBF	Mean Time Between Failures . . . . .	4
MTTR	Mean Time To Repair . . . . .	4
pdf	probability density function . . . . .	5
CTMC	Continuous Time Markov Chain . . . . .	5
RBD	Reliability Block Diagram . . . . .	5
FT	Fault Tree . . . . .	5
ET	Event Tree . . . . .	6
EON	Event Occurrence Network . . . . .	9
iid	independently and identically distributed . . . . .	10
cdf	cumulative distribution function . . . . .	10
pmf	probability mass function . . . . .	18

# RELIABILITY OF SYSTEMS USING EVENT OCCURRENCE NETWORKS

## I. Introduction

### *1.1 Background*

The importance of products being reliable is self-evident. Counting on a particular system or component to get its intended job done in many applications is critical. This measure is even more detrimental in the military profession, when the freedom of our nation, and the lives of our soldiers and citizens are at stake. Our growing dependency on advanced technologies and complex weapon systems, makes reliability of greater concern now than ever before. Imagine perhaps the number of civilian casualties, should the reliability of a precision guided munition not be considered. Why even bother guiding the weapon at all? Or not knowing if, should the need arise, pulling the ejection handle will actually allow for safe departure from a doomed aircraft. The need for reliability theory has been evident for many years and continues to play a vital role in the military.

Reliability theory and its roots can be traced back as early as 1773, when Laplace introduced the Laplace Transform [35]. Its theories have played a crucial role in business and industry since the age of modern technology. More specifically the theory grew from the demands of World War II stemming from complex military systems in the early 50s and 60s [5]. Following the war, reliability analysis was used in many diverse commercial fields such as the automotive and aircraft industry, communications industry, and weapons systems industry [35]. As a result, many theories that are still used today, were established.

Today reliability theory is utilized in a myriad of different areas. Automotive manufacturers use reliability analysis throughout their production processes, from

acquiring the assembly materials up to developing vehicle warranties. All major manufacturing companies run their products through reliability testing to ensure they are producing a quality product. The military tests weapons and equipment to ensure the safety and effectiveness of our forces. Reliability is used extensively in life testing, structural integrity testing, machine maintenance, and replacement problems, to name a few. Having its uses in so many different fields, it is apparent that reliability theory is extremely diverse and can be used in many different ways.

The term reliability has slightly different meanings depending on its field of use. Reliability engineers define reliability as the probability that an item will perform a required function, without failure under stated conditions, for a stated period of time [5]. Actuaries, on the other hand, define reliability as the probability of survival of a group of people [19]. The bio-statistician is concerned with the reliability or lifetime of an organism. The most general of definitions describes reliability theory as a “body of ideas, mathematical models, and models directed toward the solution of problems in predicting, estimating, or optimizing the probability of survival, mean life, or more generally, life distribution of components of systems; other problems considered in reliability theory are those involving the probability of proper functioning of the system at either a specified time or an arbitrary time, or the proportion of time the system is functioning properly,” [35]. For the purpose of this thesis, the reliability of an item will be defined similar to the definition used by reliability engineers.

**Reliability:** probability that item will be adequately performing its specified purpose for a specified period of time under specified environmental conditions.

The ambiguity in the above definition is necessary in generalizing the definition so it can be applied to a vast number of reliability problems, and is resolved in specific applications.

A simplifying assumption that is often made in reliability is that the components or sub-systems are not repairable. That is, once the component or sub-system fails,

it is in a failed state for the remainder of time. This is an effective measure for evaluating system effectiveness when *down-time* cannot be tolerated [18]. The entire system in this type of model, can be represented by one of two states, *up* or *down*. A system is a given configuration of subsystems and/or components whose proper functioning over a stated interval of time determines whether the system will perform as designed [25]. Another model that is widely used, assumes the amount of time that an item spends out of service or *down* is negligible. This type of model is known as a point process. For systems of this type, the probability that the system is operating at a specified time, probability *up*, is the system's reliability. In most real world applications however, this is not the case. In other words components or sub-systems can fail, which may or may not cause entire system failure, and then be repaired to be as *good as new*. In this type of system, where short *down-times* are allowed, availability replaces reliability as a more appropriate measure of system effectiveness [18]. For the system with non-repairable components, availability is equivalent to reliability, and is equal to the probability that a system works continuously from 0 to time  $t$  [16]. For this reason the term availability, in terms of this thesis, also refers to system reliability when dealing with systems comprised of non-repairable components.

**Availability:** the ability of a system to be in a state to perform its required function under given conditions at a given instance in time.

These types of models, with repairable components, are known as alternating renewal processes. An alternating renewal process is a stochastic process that alternates between two states, *up* and *down* [22]. Initially the system is in the *up* state and it stays there for a random amount of time then moves to a *down* state. The system then stays in the *down* state for a random amount of time after which it cycles back to the *up* state, this can theoretically happen for an indefinite amount of time. Modeling this type of system is one of the primary objectives of this thesis.

## 1.2 Current Methods

System reliability is a stand-alone performance measure, where availability is not. There are four types of availability measures: 1) limiting (long-term); 2) average; 3) instantaneous; and 4) limiting average availability. More often than not limiting availability is used to determine whether a system is available or not.

- 1) Limiting Availability:** the simplest steady-state situation, where availability is equal to the mean time between failure (MTBF), divided by the mean time between failure (MTBF) plus the mean time to repair (MTTR). In other words

$$\text{Availability} = \frac{\text{MTBF}}{\text{MTBF} + \text{MTTR}}.$$

- 2) Average Availability:** most commonly approximated in simulation, average availability on an interval  $(0, c]$ , is given by

$$A_c = \frac{1}{c} \int_0^c A(t) dt.$$

where,  $A(t)$  is the instantaneous availability.

- 3) Instantaneous Availability:** the probability that the item is operating at time  $t$ .
- 4) Limiting Average Availability:** the limiting expected proportion of time the system is *up*. Or, mathematically,

$$\text{Availability} = \lim_{c \rightarrow \infty} A_c$$

[23].

The correct representation for a give system's availability depends on how the system is to be used [24]. Limiting availability is often used because it is easy to calculate. The other three measures are not as easy and are not typically found analytically. Limiting availability is adequate so long as the instantaneous, or average availability over a *short* time interval is not the measure of concern. Using limiting availability to measure a systems's availability lacks accuracy when the system of concern is being evaluated for a short period of time. For this reason using the limiting availability to describe the availability of many systems is undesirable.

For systems where average availability or the instantaneous availability is the desired computation, the exponential distribution is often assumed and used to model both the failure and repair times. The exponential distribution yields a closed form solution when integrating the probability density function (pdf). In more complicated situations with non-exponentially distributed times, Monte Carlo simulation is used as opposed to analytical approaches [23]. If the exponential assumption is made, then instantaneous availability can be obtained in closed form, and the system is easily modeled as a continuous time markov chain (CTMC). The system can be modeled as a CTMC even when failure and repair times are generally distributed, but these types of models often do not lend themselves to closed form solutions.

There are three main graphical methods used to represent and analyze system reliability. First, reliability block diagrams (RBD), and their techniques have been used by engineers for years to model systems in areas such as computers, the aircraft industry, and power plants [17]. RBDs are considered success space models. A success space model describes a system in terms of component successes required for system operation. A RBD portrays the required functional relationship between components in an operational system. At higher-levels RBDs show the functional relationship between sub-systems within the overall model.

The second graphical method, fault trees (FT), provide a compact, graphical, intuitive representation [2]. Fault tree models are failure space models, meaning

they describe events that cause system failure. The top event in a fault tree is any undesired event and its branches are the causes of this event. Each branch point is termed a *gate*. These gates can be *and gates* or *or gates*: *and gates* depict scenarios where all of the descendent events must occur for the event at the current level to occur; *or gates* on the other hand depict scenarios where only one of the descendent events needs to occur for the event at the current level to occur. When applied to the field of reliability, the top event is system failure, followed by all of the associated elements that could cause the top event to occur. Thus, the top event can be thought of as unreliability, or in systems with repairable components unavailability. There are many methods to compute this top event probability. All of these methods use the probabilities of the causes or basic events and most of them are based on minimal cut-sets and boolean algebra. Minimal cut-sets are the minimum combination of events such that, if non-operational, will cause system failure.

Third, event trees (ET), are a graphical representation that start with a cause or initiating event and terminate at all possible system scenarios. For example, an initiating event might be component one failure and the different scenarios would be an operational or failed system. ETs typically use binary operations to find probability measures. An event tree is an inductive or forward logic model, while a fault tree is a deductive or backward logic model [44]. In order to provide a detailed reliability analysis of a particular system, FTs and ETs are often combined. Typically this is done by treating the branch point of an ET as a FT.

Lastly, simulation is an approximation method that is often utilized in reliability theory. If you remove any of the simplifying assumptions or if the model is more complex, then calculating system reliability or availability becomes much more difficult [25]. Simulation often approximates average availability over the run-time interval, by dividing the amount of time the system is *up* by the total run-time. However, it can be used to approximate all of the desired reliability measures, even when failure and repair times are described by any general distribution. Thus, often times

for systems where general distributions describe the component life and repair times, simulation is used. All of these approaches have their down-falls and limitations.

### ***1.3 Current Method Limitations***

The analyst is often interested in availability at a specific instance in time, and limiting availability will not yield an accurate assessment. Calculating the instantaneous availability however, is only straight forward when component life and repair times are assumed to be exponentially distributed. If this assumption is made then the system can be modeled via a CTMC. When the exponential distribution is not used then the system becomes much more complicated and closed form solutions are typically untractable. Unfortunately, assuming component life and repair times are exponentially distributed is not always a valid assumption to make. For instance, if exponential failure times are assumed then the component will fail at a continuous rate regardless of how long it has already been operating. In many real world applications items may fail at a changing rate, whether increasing or decreasing. The tires on your car, as an example, are more likely to fail as more miles are put on them. If the exponential assumption is removed then our system's instantaneous availability becomes much more complicated to calculate, and other methods are used. So difficult in fact that very little work has been done when failure and repair times are non-exponential [24].

Using CTMCs to calculate system availability typically does not allow for the calculation of many other measures of concern, such as component *importance* measures. In CTMCs the system is often modeled in one of two states *up* or *down*. A limitation of this method is that it does not yield the probability of a particular component or group of components causing system failure. Often when studying a system's availability the component or components that drive the unavailability of the system is of great concern. In other words it is imperative to know how *important* components are to the system, especially if a cost effective component replacement strategy is desired, with a goal of improving system availability. In this case it is

important to know which component or components are the most *important* to the system. Modeling the system as a CTMC does not make all of the desired performance measures easy to calculate. When modeling these types of systems, transition probabilities are of interest, but are difficult to calculate using CTMCs. Often times, for this very reason, the limiting behavior of the CTMC is instead analyzed [22]. This is a limitation because the time element is of utmost importance in reliability. Graphical techniques are much better at capturing all of these measures.

RBDs are very good at showing the relationships between components, and what interactions between them are required for the system to be functional. They do not however have obvious, intuitive solution techniques, especially when the system being modeled is large. For this reason RBDs are converted to FTs.

FTs, are limited in the fact that they only depict and are focused on one reliability measure, the top event reliability or availability. A complete analysis of complex systems often results in thousands of combinations of events which can cause system failure, the system's cut-sets. If the FT has many minimal cut-sets then calculating the top event probability will require extensive calculations, and is time consuming [38]. Substantial improvement in computational utilization will only result from a new approach. Thus, if interested in a more detailed analysis, including specific component and combination of component failure probabilities, this method is not effective. In addition, if a system consists of repairable components, then the analysis should also include the effects of repairs, which requires a sequence dependent analysis [2]. If this is the case then the common methods used to solve FTs cannot be used, and the top event probability is not obtainable. Accurate analysis requires markov models, but even small FTs generate very large markov models and their manipulation is computationally expensive [2]. ETs share many of the same limitations that FTs do.

Simulation, can be an effective way to calculate a complex system's availability over a specified time frame. However, for large systems, simulation can be extremely

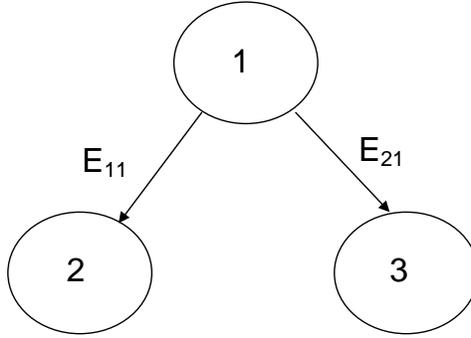

Figure 1: Example EON

costly and time consuming. Not to mention the fact that a simulation's accuracy is often in question. From this analysis it is evident that a more robust, all-inclusive, reliability analysis method should be introduced.

#### 1.4 Problem Approach

In order to meet this need, a graphical model termed an event occurrence network (EON), is applied to this field (see Figure 1).

**Event Occurrence Network:** probabilistic network that represents the superposition of several terminating counting processes.

EONs received their introduction to the stochastics world via research done by Denhard [12]. An EON is a probabilistic network in which an arc represents the occurrence of an event from a group of (sequential) events before the occurrence of a separate event or events from a different group. In this model arcs leaving a node are a set of competing events, events between groups occur independently, and events within a group occur sequentially [12].

Two separate types of nodes are used within an EON. Square nodes represent the occurrence of an event that prohibits other events from occurring. This is termed a *concluding event*, or a *terminating node* in the graph. It is equivalent to an absorbing state in the probabilistic model. Circular nodes represent the occurrence of an event

that is not a concluding event. This is termed an *intermediate event* in the graph and translates to a transient state in the probabilistic model [12].

**Terminating Node/Concluding Event:** the occurrence of an event that prohibits other events from occurring.

**Intermediate Node:** the occurrence of an event that does not prohibit other events from occurring.

An EON represents the superposition of several terminating counting processes. In this stochastic representation, each group of events has its own counting process that counts the number of event occurrences in its respective group. If the events in a given group are independently and identically distributed (iid) then the process is a renewal process where the inter-arrival times are the event occurrence times.

RBDs, FTs and ETs can all be represented as EONs. In an EON however, the set of nodes are mutually exclusive and collectively exhaustive, meaning the probability of being at any two nodes at a specific time  $t$  is zero and the sum of all the node probabilities at any time  $t$  is equal to one. Survival at time  $t$  is the probability of being at any of the intermediate nodes (transient states) at time  $t$ . In other words the probability of the system functioning or being available at time  $t$  is the sum of all the intermediate node probabilities at time  $t$ . Similarly failure at time  $t$ ,  $P\{T \leq t\}$ , the cumulative distribution function (cdf), is the probability of being at any of the terminating nodes at time  $t$ . This probability is just the sum of all the terminating node probabilities at time  $t$ .

The advantage of an EON is that it provides an all-inclusive graphical method in which to conduct reliability analysis. EONs allow for the dissection of complex systems into simple component and combination of component probabilities. Doing so allows for a complete analysis of the entire system's reliability. Using an EON, one can look at the probability of being at any node at time  $t$  and find the probability

that a specific set of events (failures) occurred. Thus, EONs allow an analyst to look at specific causes of failure and their probabilities. If the analyst is interested in a group of event occurrences, then all the analyst needs to do is sum their respective probabilities, due to mutual exclusivity. This approach is most valuable when the probability of component or components in a system causing system failure is the area of concern. One can also easily look at event stream probabilities, the probability of occurrence of a specific string of events. This cannot be done in Markovian models since the Markov property is not satisfied, in other words the total history of the system is required, not just knowledge of the previous state. EONs model competing events as opposed to states of the system. EONs also graphically depict the system in an intuitive, easy to understand manner. Looking at an EON it is easy to determine which components or series of components will cause a system to fail or become unavailable.

In this thesis, system reliability and availability will be found using EONs. For systems with component life and repair times that are generally distributed, a piecewise polynomial approximation technique is used to resolve probabilities that do not have closed form integral solutions. If the times are assumed exponentially distributed then system availability can be calculated exactly. This assumption will be used as the baseline approach in order to validate the proposed model.

### ***1.5 Research Scope***

This research focuses on the reliability and instantaneous availability of systems using event occurrence networks. This work follows that of [12], but applies techniques he developed to a new field; reliability.

These techniques are used to develop a new, all-inclusive, robust method to perform reliability analysis for any system, whether its made up of non-repairable or repairable components. Some aspects of this analysis include probabilities of different components or sub-systems or combinations of these causing system unavailability,

component importance, and total system availability. The research outlines a method to be used for complex systems in place of simulation with more accurate results.

## **1.6 Overview**

This thesis is divided into six chapters. In this chapter the reliability of systems using EONs, the background behind it, and its motivation was presented. Current methods and their limitations were discussed in order to validate the need for new techniques in this area. Lastly, a brief overview of the problem approach was given and the scope of the research was defined.

Chapter 2 is divided into two main sections. The first gives a detailed introduction to EONs and their applications. More specifically, the first section goes over the work done previously by Denhard in [12], and provides a thorough literature review on his findings and sources. The second section provides a thorough review of reliability theory.

EONs and their application to the reliability of non-repairable systems will be the main topic for Chapter 3. This chapter shows how EONs can be used in many different areas of reliability theory in an efficient manner. Chapter 4 extends the methodology discussed in Chapter 3 to repairable systems.

Next, the results and illustrations are detailed in Chapter 5. Finally, Chapter 6 summarizes the results and provides a look at future research in this area. More precisely the chapter provides recommendations on areas to expand on the methodology derived in this research.

## II. Literature Review

### *2.1 Overview of Event Occurrence Networks and Reliability Theory*

This chapter provides a review of event occurrence networks and of reliability theory. The chapter begins by discussing the probabilistic model introduced by [12], termed an event occurrence network (EON). Following this introduction, a thorough review of the reliability of systems with non-repairable and repairable components is given, according to [3], [23], [25], and [19].

### *2.2 EON Introduction*

An EON is used to model several groups of competing sequential events. More specifically it is the superposition of several terminating counting processes [12]. This chapter first gives a detailed description of EONs. Second, terms and notation used throughout this thesis will be defined. Third, the underlying probabilistic models in an EON will be discussed, focusing primarily on the probability of being at a node or set of nodes at a particular time  $t$ : nodal probabilities. Last, the node explosion problem associated with EONs is addressed.

### *2.3 Description [12]*

An EON is a probabilistic model consisting of nodes and arcs. Generally speaking, a probabilistic model is a simple way to model structural relationships between events. Probabilistic models show possible paths of occurrence, graphically represent underlying probabilistic models, and are useful in helping to formulate possible solution techniques for more complex problems. An arc in an EON represents the occurrence of an event from a group of sequential events before the occurrence of events from another group or groups of sequential events. Arcs leaving the same node are a set of competing events. Events between groups occur independently of each other and events within any one group occur sequentially.

In addition to arcs, EONs also consist of nodes. There are two types of nodes used in an EON, intermediate and terminating nodes, representing intermediate and

concluding events respectively. Intermediate events are represented by circles in the model, and signify the occurrence of an event that is not a concluding event. These intermediate nodes are equivalent to transient states in the probabilistic model. Terminating nodes on the other hand are represented by squares in the model. Terminating nodes or concluding events are events that preclude or prohibit any other event from occurring. Concluding events are equivalent to absorbing states in the probabilistic model. In order to make the next section easier to comprehend a new term is introduced.

**Tier:** level in the EON graphical model or the number of events that have occurred thus far.

Each tier is made up of all possible unique combinations of events that have occurred thus far, where these unique combinations are represented by nodes. This will become more clear with a simple example. To better understand this model, the following notation will be used throughout. Suppose there are  $n$  groups of  $k_i$  sequential events, where  $i$  is the group number ( $i = 1, \dots, n$ ).

$$\begin{aligned}
 &G_{11}, G_{12}, \dots, G_{1k_1} \\
 &G_{21}, G_{22}, \dots, G_{2k_2} \\
 &\quad \vdots \\
 &G_{n1}, G_{n2}, \dots, G_{nk_n}
 \end{aligned}$$

Let  $E_{ie}$  be the event occurrence (completion) time of event  $G_{ie}$  where  $i$  is the group number and  $e$  is the event number in group  $i$  with

- pdf-  $f_{E_{ie}}(t)$ ,
- cdf-  $F_{E_{ie}}(t)$ , and
- Survivor Function-  $S_{E_{ie}}(t)$  where  $S_{E_{ie}}(t) = 1 - F_{E_{ie}}(t)$ .

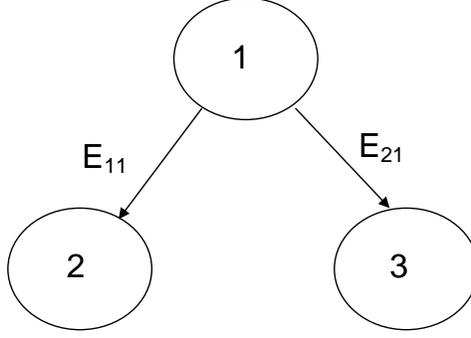

Figure 2: Simple EON

In addition, only one event can occur at any given instance in time. In other words the probability of two or more events occurring at the same time is zero.

As stated before, an EON is the superposition of several terminating counting processes. A counting process  $\{N(t), t \geq 0\}$  is a stochastic process in which  $N(t)$  counts the total number of events that have occurred up to time  $t$ . Mathematically, let

$$X_n \equiv \text{time interval between } (n-1)^{\text{st}} \text{ and } n^{\text{th}} \text{ event,}$$

$$\{X_n, n \geq 1\} \equiv \text{set of all time intervals,}$$

$$S_n \equiv \text{time occurrence of the } n^{\text{th}} \text{ event,}$$

$$S_0 = 0,$$

$$S_n = X_1 + X_2 + \dots + X_n, \text{ then}$$

$$N(t) = \sup\{n \geq 0 : S_n \leq t\}.$$

There is a counting process for each group of sequential events where  $E_{ie}$  is the inter-arrival time for group  $i$ . If all the  $E_{ie}$  are independently and identically distributed (iid) for a group, then  $\{N(t), t \geq 0\}$  is a renewal process. Moreover if the interarrival times,  $E_{ie}$ , are exponentially distributed then  $\{N(t), t \geq 0\}$  is a Poisson process.

As an example consider the simple EON shown in Figure 2. For this two event EON, there are two event groups each containing one event,  $G_{11}$  and  $G_{21}$ . In this

example, and in all EONs for that matter, the top node (node one) represents the *non-event*. This is the event where neither of the two events of interest have yet occurred. The EON in 2 is made up of two tiers. Tier zero consists of node one, and tier one is made up of nodes two and three. Note that, as stated before, tier zero represents the case where no events have occurred. Similarly, tier one is made up of two unique cases (nodes), each representing the occurrence of only one event. Generically speaking,  $P_i(t)$  denotes the probability of being at node  $i$  at time  $t$ . Mathematically, the probability of being at node one at time  $t$ , is the probability that none of the events have occurred by time  $t$ , and is given as

$$P_1(t) = P \{E_{11} > t, E_{21} > t\}.$$

The probability of being at node 2 at time  $t$ , the probability that arc 12 is chosen, is equivalent to the probability that event  $G_{11}$  occurs before  $G_{21}$ , for time less than  $t$ . Assume that the random variable  $T$  represents the amount of time that has elapsed thus far. The nodal probability expression is similar for node three. Mathematically

$$P_2(t) = P \{E_{11} < E_{21} | T \leq t\} \text{ and}$$

$$P_3(t) = P \{E_{21} < E_{11} | T \leq t\}.$$

Both of these expressions can be solved via conditioning.

#### ***2.4 EON Solution Techniques***

Many different standard stochastic operators are used in the analysis of EONs. The main operators being conditioning and convolution. For example, suppose  $F$  is

an event of interest and  $X$  is a random variable then, using a conditioning argument,

$$P\{F\} = \sum_x P\{F|X = x\} P\{X = x\} \text{ in the discrete case,}$$

$$P\{F\} = \int_{-\infty}^{\infty} P\{F|X = x\} f_X(x) dx \text{ in the continuous case.}$$

Now suppose the event of interest (what was termed  $F$  above), is the event where one random variable occurs prior to the other. This is exactly the probability expression shown above, in the simple EON example. In other words the quantity of interest is  $P\{X_1 < X_2\}$ . If  $X_1$  and  $X_2$  are exponentially distributed with respective rates  $\lambda_1$  and  $\lambda_2$ , then this probability is easy to find. It is given as

$$\begin{aligned} P\{X_1 < X_2\} &= \int_0^{\infty} P\{X_1 < X_2|X_1 = x\} f_{X_1}(x) dx \\ &= \int_0^{\infty} P\{X_2 > x\} \lambda_1 e^{-\lambda_1 x} dx \\ &= \int_0^{\infty} S_{X_2}(x) \lambda_1 e^{-\lambda_1 x} dx \\ &= \int_0^{\infty} e^{-\lambda_2 x} \lambda_1 e^{-\lambda_1 x} dx \\ &= \left( \frac{-\lambda_1}{\lambda_1 + \lambda_2} \right) e^{-(\lambda_1 + \lambda_2)x} \Big|_0^{\infty} \\ &= \left( \frac{\lambda_1}{\lambda_1 + \lambda_2} \right). \end{aligned}$$

In addition to conditioning, convolution is another operator that is valuable when looking for nodal probabilities in an EON.

**Convolution:** mathematical operator which takes two functions and produces a third function that represents the amount of overlap between the two functions [7].

This is also known as the folding of the two functions [7]. For example suppose  $X$  and  $Y$  are independent continuous random variables with pdf's  $f_X$  and  $f_Y$  and cdf's given by  $F_X$  and  $F_Y$  respectively. If  $Z = X + Y$  is the random variable of

interest then  $f_Z$ ,  $Z$ 's pdf, is the convolution of  $f_X$  and  $f_Y$ . Where as  $F_Z$ ,  $Z$ 's cdf, is the convolution of  $F_X$  and  $F_Y$ . According to [22]

$$f_Z(z) = \int_{-\infty}^{\infty} f_X(x)f_Y(z-x)dx = \int_{-\infty}^{\infty} f_Y(x)f_X(z-y)dy \text{ and}$$

$$F_Z(z) = \int_{-\infty}^{\infty} F_Y(z-x)dF_X(x) = \int_{-\infty}^{\infty} F_X(z-y)dF_Y(y).$$

If  $X$  and  $Y$  are two discrete, independent random variables then the probability mass function (pmf) of  $Z$ ,  $p_Z(z)$ , is

$$p_Z(z) = \sum_x p_X(x)p_Y(z-x).$$

As an example consider the case when  $X$  and  $Y$  are iid exponentially distributed random variables with rate  $\lambda$ . The cdf,  $F_Z$  is given as

$$\begin{aligned} F_Z(z) &= \int_{-\infty}^{\infty} F_Y(z-x)dF_X(x) \\ &= \int_0^z (1 - e^{-\lambda(z-x)})\lambda e^{-\lambda x} dx \\ &= \lambda \int_0^z e^{-\lambda x} - e^{-\lambda z} dx \\ &= 1 - e^{-\lambda z} - \lambda z e^{-\lambda z}. \end{aligned} \tag{1}$$

Note the sum of two iid exponential ( $\lambda$ ) random variables is Gamma distributed with cdf equal to the expression shown above [22]. The pdf for this convolution is

$$f_z(z) = \lambda^2 z e^{-\lambda z}.$$

Similarly, if  $X$  and  $Y$  are two independent exponentially distributed random variables with different respective rates  $\gamma_1$  and  $\gamma_2$  ( $\gamma_1 \neq \gamma_2$ ), then the cdf for  $Z$  is

found using the above convolution formula which gives

$$\begin{aligned}
F_Z(z) &= \int_0^z F_Y(z-x)f_x(x)dx \\
&= \int_0^z (1 - e^{-\gamma_2(z-x)}) \gamma_1 e^{-\gamma_1 x} dx \\
&= \gamma_1 \int_0^z e^{-\gamma_1 x} - e^{\gamma_2 z} e^{(\gamma_2 - \gamma_1)x} dx \\
&= 1 - e^{-\gamma_1 z} - \gamma_1 e^{-\gamma_2 z} \int_0^z e^{(\gamma_2 - \gamma_1)x} dx \\
&= 1 - e^{-\gamma_1 z} - \left( \frac{\gamma_1 e^{-\gamma_2 z}}{\gamma_2 - \gamma_1} \right) (e^{(\gamma_2 - \gamma_1)z} - 1) \\
&= 1 + \frac{-\gamma_2 e^{-\gamma_1 z} + \gamma_1 e^{-\gamma_1 z} - \gamma_1 e^{-\gamma_1 z} + \gamma_1 e^{-\gamma_2 z}}{\gamma_2 - \gamma_1} \\
&= 1 + \frac{-\gamma_2 e^{-\gamma_1 z} + \gamma_1 e^{-\gamma_2 z}}{\gamma_2 - \gamma_1}. \tag{2}
\end{aligned}$$

This is the cdf for what is termed the hypo-exponential distribution [7]. It has pdf

$$f_z(z) = \frac{\gamma_1 \gamma_2}{\gamma_1 - \gamma_2} (e^{-\gamma_2 z} - e^{-\gamma_1 z}). \tag{3}$$

## 2.5 Underlying Probabilistic Model

As in the example given above, in EONs the probability of being at a node or set of nodes at time  $t$  is the measure of greatest interest. According to [12], “the probabilistic model generated by the EON structure is a non-Markovian probabilistic model.” In other words, to calculate the probability of being at any particular node in the network requires a knowledge of the history of all completed events. In a Markovian model only knowledge of the previous state is required. The states of the underlying probabilistic model correspond on a one-to-one basis with the nodes of the EON. This means that in the EON, event sequences that end with a concluding event are equivalent to absorbing states in the probabilistic model. Similarly, event sequences that end with an intermediate event in the EON are equivalent to transient states in the underlying probabilistic model [12].

As was seen in the simple EON example given in Figure 2 on page 15, finding the probability of being at a particular node is equivalent to finding the probability of the associated event order relationship occurring. Now if the analyst is interested in the probability of being at a group of nodes at time  $t$  then the sum of their respective probabilities at time  $t$ , is the desired computation. These features are what make EONs desirable in system reliability modeling.

## 2.6 Piecewise Polynomial Approximation [12]

Finding the probability of being at a node or set of nodes at some time  $t$  typically involves integral or multiple integral expressions. These integral expressions are made up of the event's probability density functions and require multiplication, convolution and conditional arguments. Often times these expressions cannot be solved in a closed form and for this reason piecewise polynomial approximation or simulation is used. Per [12], piecewise polynomial approximation with bucket analysis (Section 2.7), has shown the most promise as a solution technique for EONs.

**Piecewise Polynomial ( $\rho(x)$ ):** polynomial that is continuous over a closed interval  $[a, b]$ , made up of  $n - 1$  different polynomials that are each in-turn defined over  $n - 1$  subintervals,  $I_k \in [a, b]$ .

More precisely define the sub-intervals as shown. If

$$a = x_1 < x_2 < \dots < x_n = b, \text{ then}$$

$$I_k = \left\{ \begin{array}{l} [x_k, x_{k+1}] \quad \text{for } k = 1, 2, \dots, n - 1. \end{array} \right.$$

Now define

$$\mathbb{P}^m \equiv \text{linear space of all polynomials of degree } m.$$

In other words,

$$\mathbb{P}^m = \{p(x) : p(x) = \sum_{j=0}^m c_j x^j, c_j \in \mathbb{R}\}.$$

Now, it is possible to define  $\rho(x)$ . There exists polynomials,

$$p_k(x) \in \mathbb{P}^m \text{ such that}$$

$$\rho(x) = p_k(x) \text{ for } x \in I_k, \quad k = 1, 2, \dots, n - 1.$$

To ensure  $\rho(x)$  is continuous and smooth between the polynomials at the *knots* ( $x_k$ ), the following must hold:

$$\frac{d^l p_i}{dx}(x_{i+1}) = \frac{d^l p_{i+1}}{dx}(x_{i+1}) \text{ for } i = 1, 2, \dots, n - 2 \text{ and } l = 0, \dots, m.$$

Denhard, makes use of these polynomials in approximating the area (probability) under the given curves for the associated nodal probability expressions.

## ***2.7 Node Explosion Problem and Bucket Analysis***

There is however one problem associated with EONs. Due to the fact that unique occurrence sequences are modeled, the number of nodes required in the network can be quite large. As one might imagine, as the number of events is increased the number of unique event streams grows at an exponential rate.

The technique used by [12] to deal with this is node truncation. Truncation, is the process by which nodes and event sequences are eliminated. In this process, event sequences with *small* chances of occurrence and their associated nodes are eliminated from the EON graph and underlying probabilistic model. This results in smaller networks at a cost of lost explicitness in the model. The process by which this is accomplished is termed *bucket analysis* [12].

In bucket analysis, intermediate nodes are transformed into terminating nodes. This reduces the number of nodes in subsequent tiers in the EON. One might think of this as pruning the network. This method truncates *rare* (as defined by the analyst) event sequences with their top-level associated nodes. When nodes are truncated by the method described above, event sequences from remaining nodes are removed as

well. To describe this a little more clearly, a fluid analogy is used. At  $t = 0$  the probability of being at node one (the non-event) is equal to one. As time goes on, the probability *flows* down to the other nodes, collecting in the concluding event nodes. Thus, the concluding events (absorbing states), can be thought of as buckets, hence the term *bucket analysis*. Intermediate nodes are thought of as *leaky buckets*, where fluid (probability) is collected but then *leaked* to subsequent nodes in lower tiers. As time goes to infinity, only the terminating nodes contain fluid (probability) [12]. Using bucket analysis and the fluid analogy, a leaky bucket is replaced, and an intermediate node is turned into a terminating node, pruning subsequent event tiers.

## ***2.8 Reliability Theory Introduction***

As was mentioned in Chapter 1, the reliability of an item is the probability that it will be adequately performing its specified purpose for a specified period of time under specified environmental conditions. This half of the chapter will review several different topics in reliability theory. First, coherent system analysis and its applications will be reviewed. Second, lifetime distributions are discussed. Third, an analysis of repairable systems is given.

## ***2.9 Coherent System Analysis***

In order to conduct a thorough study of reliability theory, it is first necessary to define some terms and review some basic theory. To analyze system reliability it is necessary to have knowledge of the configuration of components, the failure mode of each component, and the states in which the system is considered failed [25]. Coherent system analysis addresses all of these issues.

The most intuitive way in which to represent systems when trying to determine the reliability of a given system, is via a diagram consisting of binary functions, generally known as a structure function [23], [25]. In this system the state of a

component  $i$ ,  $x_i$ , termed a state variable, is defined as

$$x_i = \begin{cases} 1 & \text{component working} \\ 0 & \text{component failed.} \end{cases}$$

These systems are known as reliability block diagrams (RBDs), which will be discussed in greater detail later in the section. The state of all the components in a system of  $n$  components at a particular instance in time, known as the system's state vector, is defined as

$$\mathbf{x} = (x_1, x_2, \dots, x_n).$$

Similarly, the structure function  $\phi(\mathbf{x})$ , is the status of the entire system with state vector  $\mathbf{x}$ , and

$$\phi(\mathbf{x}) = \begin{cases} 1 & \text{system functioning when state vector is } \mathbf{x} \\ 0 & \text{system failed when state vector is } \mathbf{x}. \end{cases}$$

Any vector  $\mathbf{x}$ , for which  $\phi(\mathbf{x}) = 1$  is called a path for the structure  $\phi$ . Similarly, any vector  $\mathbf{x}$ , for which  $\phi(\mathbf{x}) = 0$  is called a cut for the structure  $\phi$ .

**Coherent System:** according to [25], “a system which is in a failed state when all of its components are in failed states; is in a functioning state when all of its components are in functioning states; and, if initially in a functioning state for a state of its components, remains in a functioning state whenever some components that were initially in failed states are restored to functioning states.” Alternatively, [3] and [23] suggest that a system of components is coherent if  $\phi(\mathbf{x})$  is non-decreasing in  $\mathbf{x}$  (or  $\phi(x_1, \dots, x_{i-1}, 0, x_{i+1}, \dots, x_n) \leq \phi(x_1, \dots, x_{i-1}, 1, x_{i+1}, \dots, x_n)$  for all  $i$ ) and each component is relevant.

A non-decreasing structure function implies that the system's state will not improve if a component degrades. A component is irrelevant if its state has no impact



Figure 3: RBD of 3 Components in Series

on system performance, or the structure function [23]. The remainder of this section is devoted to discussing methods used in coherent system analysis.

There are two basic configurations of components in a RBD, *series* or *parallel*.

**Series System:** system that only functions when all of its components function.

Mathematically, using the notation just discussed,

$$\phi(\mathbf{x}) = \begin{cases} 1 & \text{if } \mathbf{x} = \mathbf{1} \\ 0 & \text{otherwise.} \end{cases}$$

This is also written as

$$\begin{aligned} \phi(\mathbf{x}) &= \min\{x_1, x_2, \dots, x_n\} \\ &= \prod_{i=1}^n x_i. \end{aligned}$$

A RBD of a simple system with 3 components in series is shown in Figure 3.

**Parallel System:** system that operates when  $k$  or more of its components are functioning. If  $k = 1$ , the system is called purely parallel. A purely parallel system fails only when all of its components fail. When  $k > 1$  then the system is referred to as a  $k$  out of  $n$  system.

Note that, both series and parallel systems are a special case of a  $k$  out of  $n$  system [25]. If  $k = n$  then this is a series system. Mathematically, for a purely parallel

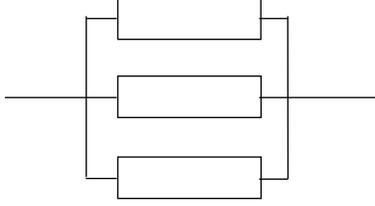

Figure 4: RBD of 3 Components in Parallel

system,

$$\begin{aligned}\phi(\mathbf{x}) &= \max\{x_1, x_2, \dots, x_n\} \\ &= 1 - \prod_{i=1}^n (1 - x_i).\end{aligned}$$

The RBD of a simple 3 component purely parallel system is shown in Figure 4.

In addition to simple systems that consist of components that are all in parallel or in series, any combination of these arrangements is possible. These systems can all be represented as  $k$  out of  $n$  systems, where any combination of  $k$  out of  $n$  of the components are required to function in order for the system to be operational [23]. Mathematically, the structure function for a  $k$  out of  $n$  system is defined as

$$\phi(\mathbf{x}) = \begin{cases} 1 & \text{if } \sum_{i=1}^n x_i \geq k \\ 0 & \text{if } \sum_{i=1}^n x_i < k. \end{cases}$$

It is important to note that the aforementioned series and parallel system's structure functions place bounds on all coherent system's structure functions [3], more specifically

$$\prod_{i=1}^n x_i \leq \phi(\mathbf{x}) \leq 1 - \prod_{i=1}^n (1 - x_i).$$

Now that some of the basic arrangements of components has been discussed, a review of some important reliability terms will be given. The first is structural importance. The structural importance is a quantity used to measure how critical a

certain component is to a given system. For the  $i^{th}$  component it is defined as

$$I_\phi(i) = \frac{1}{2^{n-1}} \sum_{\{\mathbf{x}|x_i=1\}} [\phi(1_i, \mathbf{x}) - \phi(0_i, \mathbf{x})].$$

In other words the importance of component  $i$  is the sum of structure function with component  $i$  operating minus the structure function without component  $i$  operating over all values of  $\mathbf{x}$  such that  $x_i = 1$ , times a constant. It is worthwhile to note that this measure will always produce a number between 0 and 1. This measure is notable, because it provides a way to identify crucial components, thus producing an effective method used when attempting to improve system reliability [23].

Other areas of study in reliability use methods that utilize minimal path and cut sets.

**Path Vector:** a vector  $\mathbf{x}$  is termed a path vector for a coherent system if, the system operates under the state it describes, i.e.  $\phi(\mathbf{x}) = 1$ .

**Minimal Path Vector:** a vector  $\mathbf{x}$ , such that if any of the components described by it shutting down will cause the system to stop functioning.

Mathematically

$$\mathbf{x} < \mathbf{y} \Leftrightarrow x_i \leq y_i \quad \forall \quad i \text{ and } x_i < y_i \text{ for at least one } i.$$

Using the above definition, a minimal path vector is a vector  $\mathbf{x}$ , such that

$$\phi(\mathbf{y}) = 0 \text{ for any } \mathbf{y} < \mathbf{x} \text{ (not unique).}$$

The opposite of a path vector is a cut vector.

**Cut Vector:** a vector  $\mathbf{x}$  is termed a cut vector for a coherent system if, the system does not operate under the state it describes, i.e.  $\phi(\mathbf{x}) = 0$ .

**Minimal Cut Vector:** cut vector  $\mathbf{x}$  such that any component turning on will cause the system to operate [23], [25], [19].

Mathematically, a cut vector  $\mathbf{x}$  is called a minimal cut vector if

$$\phi(\mathbf{y}) = 1 \quad \forall \quad \mathbf{y} > \mathbf{x}.$$

A path vector  $\mathbf{x}$  has an associated path set corresponding to the functioning components, while a cut vector has a corresponding cut set consisting of the failed components. More common, minimal path and cut sets, are the sets that correspond to the respective minimal path and cut vectors for the given system. Minimal cut sets are used throughout reliability and related fields such as risk analysis [19]. In reliability theory, RBDs, structure functions, minimal path sets, and minimal cut sets for a specified system are equivalent and completely define system reliability. The question becomes how are all of these used?

Some baseline reliability calculation techniques are now presented. In order to develop these baseline techniques, simplifying assumptions need to be made. First, assume that the models are not repaired, repairable systems will be discussed later in this thesis. Second, assume that components operate independently of one another. Now some terms are defined that allow for a better description of the methods used, first let

$$p_i \equiv P \{x_i = 1\}.$$

The vector made up of these  $p_i$ ,  $\mathbf{p}$ , is called a reliability vector. The reliability function,  $r(\mathbf{p})$ , is the quantity of most interest. It is defined as the probability that the system

is functioning or

$$r(\mathbf{p}) = P \{ \phi(\mathbf{x}) = 1 \}.$$

There are four main and equivalent ways to calculate  $r(\mathbf{p})$ : 1) the method of expectation; 2) the path vector technique; 3) the cut vector technique; 4) and decomposition.

**1) Method of Expectation:** uses the fact that the expected value of an indicator variable is equivalent to the probability that the indicator variable is equal to one. Thus,

$$\begin{aligned} r(\mathbf{p}) &= E[\phi(\mathbf{x})] = P \{ \phi(\mathbf{x}) = 1 \} (1) + P \{ \phi(\mathbf{x}) = 0 \} (0) \\ &= P \{ \phi(\mathbf{x}) = 1 \}. \end{aligned}$$

**2) Path Vector Technique:** finds system reliability via summing the probabilities that correspond to the all of the different possible path vectors for the system. This method works so long as the components are independent, which makes the path vectors mutually exclusive.

According to [3], if  $P_j$  represents the  $j^{th}$  minimal path set where  $j = 1 \dots p$ , and  $p$  is the number of minimal path sets, then

$$\phi(\mathbf{x}) = 1 - \prod_{j=1}^p \left[ 1 - \prod_{i \in P_j} x_i \right].$$

In other words the system functions if and only if all of the components in one of its minimal path sets function.

**3) Cut Vector Technique:** similar to the path vector technique, but takes the opposite route and finds  $r(\mathbf{p})$  by calculating one minus the sum of all the probabilities of the cut vectors. The sum of the probabilities that correspond to the cut vectors is equal to system unreliability. As in the path vector technique, component independence must be assumed. The path and cut vector techniques illustrate the fact that system reliability and system unreliability must sum to 1.

Once again, according to [3], if  $K_j$  represents the  $j^{th}$  minimal cut set where  $j = 1 \dots k$ , and  $k$  is the number of minimal cut sets, then

$$\phi(\mathbf{x}) = \prod_{j=1}^k \left[ 1 - \prod_{i \in K_j} (1 - x_i) \right].$$

In other words the system fails if and only if all of the components in one of its minimal cut sets fail.

**4) Decomposition:** finds  $r(\mathbf{p})$  by finding a key component and conditioning on its state (functioning or failed). Used, due to its simplification qualities, in more complex systems [23].

It is important to note that there are two main rules that can be used when finding the reliability of a given system. First, if the components are all in series then the reliability of the system is just the product of the component probabilities. Mathematically for a series system with  $n$  components,

$$r(\mathbf{p}) = \prod_{i=1}^n p_i.$$

This is known as the product rule [25]. Now, if the components are all arranged in parallel, only one component needs to operate in order for the system to work thus

the reliability of the system is one minus the probability that all of the components failed,

$$r(\mathbf{p}) = 1 - \prod_{i=1}^n (1 - p_i).$$

Although not specifically mentioned thus far, component lifetimes have been thought of as discrete. In the real-world however lifetimes probabilities can be discrete or continuous. Common ways in which lifetimes are distributed are discussed next.

### ***2.10 Lifetime Distributions***

There are five different lifetime distributions that are commonly used in the field of reliability. All of the distributions are equivalent and once one distribution is obtained they all can be derived from it. The five distributions are the survivor function, the pdf, the hazard function, the cumulative hazard function, and the mean residual life.

#### 1. Survivor Function

As discussed before the survivor function is the probability that the system is functioning at time  $t$ , or one minus the cdf. The survivor function satisfies the following properties:

(a.)

$$S(0) = 1$$

(b.)

$$\lim_{t \rightarrow \infty} S(t) = 0$$

(c.)

$S(t)$  is non-increasing

#### 2. pdf

The pdf is no different than pdfs used in other fields and vastly in statistics. It must satisfy the following properties:

(a.)

$$\int_0^{\infty} f(t)dt = 1$$

(b.)

$$f(t) \geq 0 \quad \forall \quad t$$

### 3. The Hazard Function

The hazard function is commonly referred to as the instantaneous failure rate or just the failure rate and is equal to the quotient of the pdf over the survivor function,

$$h(t) = \frac{f(t)}{S(t)}$$

and  $h(t)$  must satisfy:

(a.)

$$\int_0^{\infty} h(t)dt = \infty$$

(b.)

$$h(t) \geq 0 \quad \forall \quad t$$

### 4. Cumulative Hazard Rate

The next distribution is derived in an intuitive manner, having found  $h(t)$ , you integrate it to get  $H(t)$ . This is exactly what is done when obtaining the cdf from the pdf.

$$H(t) = \int_0^t h(u)du$$

It satisfies the following:

(a.)

$$H(0) = 0$$

(b.)

$$\lim_{t \rightarrow \infty} H(t) = \infty$$

## 5. Mean Residual-Life Function

Lastly, the mean residual-life function gives the expected remaining life, given that the item has survived to some time  $t$ .

$$\begin{aligned} L(t) &= E[T - t | T \geq t] \\ &= \frac{1}{S(t)} \int_t^\infty (u f(u) du) - t. \end{aligned}$$

The mean residual-life function satisfies the following properties:

(a.)

$$L(t) > 0$$

(b.)

$$L'(t) \geq -1$$

(c.)

$$\int_0^\infty \left( \frac{dt}{L(t)} \right) = \infty$$

[23].

If the assumption of non-repairable components is lifted then system reliability becomes the probability that the system is available at a particular moment in time and this is termed availability. Martz, [25] defines availability as “a measure of the effectiveness of a maintained system that incorporates the concepts of both reliability and maintainability.” If the system has no repair capability then system availability is equal to system reliability. However, in general system reliability is less than system availability, since the reliability measure requires failure-free operation to time  $t$  [25].

### **2.11 Repairable Systems**

In most real-world applications systems have repairable components and the analyst is interested in the probability that the system will be available for use. If this is the case then information on both the life and repair time of the component is

required. In its most general state

$$\text{Availability} = \frac{\text{Operating Time}}{\text{Operating} + \text{Down Time}}.$$

There are four types of availability that are of interest: instantaneous; limiting; average; and limiting average availability [23]. Instantaneous availability,  $A(t)$ , is the availability at a particular instance in time,  $t$ . In other words the probability that the system is functioning at  $t$ . Instantaneous availability is the most valuable of these measures, because all three of the other measures can be derived from it:

$$\begin{aligned} \text{Limiting availability } A &= \lim_{t \rightarrow \infty} A(t); \\ \text{Average availability on } (0, c] \ A_c &= \frac{1}{c} \int_0^c A(t) dt \quad (\text{for } c > 0); \text{ and} \end{aligned}$$

$$\text{Limiting average availability on } (0, c] \ A_\infty = \lim_{c \rightarrow \infty} A_c.$$

The representation of availability depends on the specific circumstance under which it is being used: limiting availability for systems that are operated continuously; average availability for systems used in cycles; and instantaneous for systems that are required to perform at any random time [24]. Instantaneous availability is also the availability measure that is most similar to the reliability definition discussed previously, and the focus of this research.

When components are repairable then availability replaces reliability as the measure of interest. Due to the time parameter, expressions for availability in most situations are hard to obtain, and deriving a closed form expression for  $A(t)$  is very difficult [25]. Calculating component availability alone can be quite difficult. When life and repair times are not exponentially distributed explicit, closed form solutions for availability are extremely difficult to compute. Component availability can be found explicitly, when component life and repair times are exponentially distributed. For example, suppose simple system, consisting of one component is being analyzed, with *up* and *down* states whose failure and repair times are exponentially distributed,

with rates  $\lambda$  and  $\mu$  respectively, system availability can be found via conditioning as shown below.

$$\begin{aligned}
P \{\text{sys available at time } t+\Delta t\} &= P \{\text{sys doesn't fail in } t+\Delta t\} A(t) \\
&\quad + P \{\text{sys repaired in } t+\Delta t\} (1 - A(t)) \\
&= A(t + \Delta t) = (1 - \lambda\Delta t)A(t) + \mu\Delta t(1 - A(t)) \\
&= A(t) - \lambda\Delta tA(t) + \mu\Delta t - A(t)\mu\Delta t.
\end{aligned}$$

This leads to the differential equation,

$$\frac{A(t + \Delta t) - A(t)}{\Delta t} = -\lambda A(t) + \mu - A(t)\mu.$$

Letting  $\Delta t \rightarrow 0$  gives,

$$A'(t) = -(\lambda + \mu)A(t) + \mu,$$

with initial condition

$$A(0) = A_0 = 1.$$

For a differential equation of the form;

$$\dot{x} = ax + b \text{ with initial condition } x_0,$$

the solution is given as

$$x(t) = \left(x_0 + \frac{b}{a}\right) e^{at} - \frac{b}{a}.$$

Therefore,

$$\begin{aligned}
A(t) &= \left(1 - \frac{\mu}{\lambda + \mu}\right) e^{-(\lambda + \mu)t} + \left(\frac{\mu}{\lambda + \mu}\right) \\
&= \left(\frac{\lambda}{\lambda + \mu}\right) e^{-(\lambda + \mu)t} + \left(\frac{\mu}{\lambda + \mu}\right)
\end{aligned} \tag{4}$$

[23].

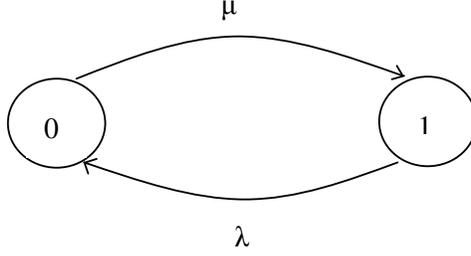

Figure 5: Transition Diagram for Alternating Renewal Process

The above result (Eq. (4)) can also be used to find the average availability on the interval  $(0, c]$ .

$$\begin{aligned}
 A_c &= \frac{1}{c} \int_0^c A(t) dt \quad (\text{for } c > 0) \\
 &= \frac{1}{c} \int_0^c \left[ \left( \frac{\lambda}{\lambda + \mu} \right) e^{-(\lambda + \mu)t} + \left( \frac{\mu}{\lambda + \mu} \right) \right] dt \\
 &= \frac{1}{c} \left[ \left( \frac{\mu c}{\lambda + \mu} \right) + \left( \frac{\lambda(1 - e^{-(\lambda + \mu)c})}{(\lambda + \mu)^2} \right) \right]. \tag{5}
 \end{aligned}$$

Note that, in this case, the limiting values of Equations (4) and (5) give the limiting availability,  $A$  [40]. In other words  $A = A_\infty$ , where

$$A = \lim_{t \rightarrow \infty} A(t) = \left( \frac{\mu}{\lambda + \mu} \right),$$

and

$$A_\infty = \lim_{c \rightarrow \infty} A_c = \left( \frac{\mu}{\lambda + \mu} \right).$$

Note that this system is known as an alternating renewal process, and can also be modeled as a Continuous Time Markov Chain (CTMC), with state space  $\mathcal{S} = \{0, 1\}$ , where “0” describes an operating system and “1” a failed system. Modeling this system as a CTMC, system availability can be derived via Laplace transforms [14], as outlined below. The transition diagram for this case is shown in Figure 5.

Using first principles, the differential-difference equations describing the stochastic behavior of the system can be obtained, where  $P_k(t)$  is the probability of being in

state  $k$  at time  $t$  [14]. They are

$$\begin{aligned}\frac{dP_0(t)}{dt} &= -\lambda P_0(t) + \mu P_1(t), \text{ and} \\ \frac{dP_1(t)}{dt} &= \lambda P_0(t) - \mu P_1(t).\end{aligned}$$

Now the Laplace transform of these two equations with initial conditions  $P_0(0) = 1$ , and  $P_1(0) = 0$ , since the system is assumed to be functioning at time 0. For notational purposes let  $f^*(s) = \mathcal{L}\{f(t)\}$ , in other words  $f^*(s)$  is the Laplace transform of  $f(t)$ . Solving this system of equations for  $P_0^*(s)$  and taking the inverse transform gives the instantaneous availability,  $A(t)$ .

$$A(t) = \mathcal{L}^{-1}\{P_0^*(s)\} = \left(\frac{\lambda}{\lambda + \mu}\right) e^{-(\lambda + \mu)t} + \left(\frac{\mu}{\lambda + \mu}\right).$$

And note that this is the same expression that was found before for  $A(t)$  using differential equations in Equation (4). To see explicitly how this is done see Appendix A.

Exponentially distributed failure times are common-place, and hence typically accepted as a valid assumption [25], [24]. This is due to the fact that many electrical and similar components fail due to over-stress, as opposed to deterioration and fatigue, and these over-stressed conditions are randomly distributed. On the other hand, exponential repair times, yielding constant repair rates, physically mean that the repairman learns nothing about the cause of the failure as he continues to work [25]. Thus, by assuming that repair times are exponentially distributed a level of explicitness in modeling real-world applications is lost. In many situations repair times are best described by the log-normal distribution [24].

If the availability for each of the components in the system can be found, then system availability can be derived in a similar fashion to that of reliability shown in Section 2.9. For example, if the system of concern consists of  $n$  components in series,

such that component  $i$  has availability  $A_i$ , then the system's availability is

$$A_{sys} = \prod_{i=1}^n A_i.$$

Conversely if these  $n$  components are arranged in parallel, then

$$A_{sys} = 1 - \prod_{i=1}^n (1 - A_i).$$

In all other cases, when the failure and repair times are not exponentially distributed, explicit solutions cannot be found for availability and simulation is often used. This is a concern, because, as will be shown later, simulation does not always yield accurate results.

### ***2.12 Summary of EON and Reliability Theory Literature***

This chapter gave a brief, but thorough review of EONs and reliability theory. The chapter began by reviewing the probabilistic model introduced by Denhard in [12]. Initially, EONs, their components, and their uses were outlined. The underlying probabilistic model was visited next, with an emphasis on the probability of being at a particular node at time  $t$ . A shortcoming to the technique, node explosion, was discussed last and a solution methodology to deal with this problem was provided.

In the reliability theory section, an analysis of the reliability of coherent systems was presented. The analysis includes a discussion of important reliability measures and techniques used to calculate them. Next, the distribution types that are commonly used to describe component lifetimes were discussed. In the last section a brief discussion of repairable systems was given. This section outlines the different types of availability measures and shows why instantaneous availability is the most robust and inclusive measure for systems with repairable components. In the following chapter, EONs and reliability theory are combined to develop a new methodology used to find the reliability of non-repairable systems.

### III. EONs and Reliability Theory

#### 3.1 *Methodology Overview for Non-Repairable Systems*

Introducing event occurrence networks (EONs) to this field will provide an efficient method that alleviates many of the current concerns. Particularly, current methods are weak in analyzing time-specific reliability measures, modeling systems with non-exponentially distributed failure and repair times [25], and in capturing multiple, different reliability measures through one method [2]. The EON structure and solution techniques are not limited in these areas and EONs can be solved via different numerical methods, with piecewise polynomial approximation being one.

This chapter, provides a methodology for calculating the reliability of systems with non-repairable components via EONs. A proof is given that shows all coherent systems can be represented as EONs, and demonstrates the validity of the technique. Next, an algorithm is given that shows how any reliability block diagram (RBD) or structure function can be transformed into an EON. Last, examples of different systems are given to demonstrate some of the techniques' specifics.

#### 3.2 *Methodology*

EONs allow for the computation of reliability in addition to other important measures, that are currently more difficult to capture, in a single reliability model. For this analysis, assume that component lifetimes are independent of each other and that once the system is in a failed state, no more component failures can take place.

In this model, the EON still represents the superposition of several terminating counting processes; however, the process terminates when a component failure causes system failure. The EON is made up of several event groups with each group representing a component in the system. Each group has only one event, namely that component's failure. An arc in this graphical depiction represents the failure of a component before the occurrence of other competing component failures. Events between the groups still occur independently, meaning that the components in the system are independent of each other and fail independently of each other. Terminating nodes,

representing concluding events, denote event streams that result in system failure. In contrast, intermediate nodes (with the exception of node one) denote event streams where components have failed, but have not caused system failure.

The number of nodes in an EON for any coherent system with  $n$  components is bounded above by the associated purely parallel system of  $n$  components, and below by the system with all  $n$  components in series. If the system consists of  $n$  components in parallel (purely parallel system), then there are no terminating streams until the last tier of the EON (when all components have failed). Thus, for any tier  $t$ , every possible combination of  $t$  component failures is feasible (system still operating). On the other hand, if the system consists of  $n$  components in series, the first tier contains all terminating nodes (one for each component failure) and other tiers are not feasible.

If the system is purely parallel, then the number of nodes in each tier  $t$ , of the EON is given by  $n$  choose  $t$ ,  $\binom{n}{t}$ . This is true, since for a purely parallel system with  $n$  components, there are  $n$  component failures before the system fails and thus there are  $n$  possible tiers in the EON. Therefore the total number of nodes in a purely parallel system is

$$= \sum_{i=0}^n \binom{n}{i}.$$

If the system consists of all components in a series arrangement, then there can be at most one component failure before system failure, and hence only one tier level in the EON. Thus for this system there are

$$\sum_{i=0}^1 \binom{n}{i} = n + 1$$

total nodes. Therefore, in general, the total number of nodes for any system is bounded above and below in the following manner,

$$n + 1 \leq \text{total number of nodes} \leq \sum_{i=0}^n \binom{n}{i}.$$

To find the reliability of a system, using an EON, the path vector or cut vector technique can be used. Each of the event streams that end in an intermediate node in an EON, represents a path vector in the associated system. Thus, finding the reliability is easily accomplished by summing the probabilities of being at any of the intermediate nodes at time  $t$ . The event streams ending with terminating nodes, on the other hand represent system cut vectors. Therefore, finding the probability of failure of a system at time  $t$ , is done via summing the probabilities of being at any of the terminating nodes at time  $t$ . These results are proved below.

*3.2.1 Proof.* This proof seeks to show that event streams ending in intermediate (terminating) nodes in an EON correspond to path (cut) vectors in the RBD and vice versa. First, it is imperative to realize that each event in a reliability EON represents the occurrence of a failed component. Thus each node in the EON corresponds to a state vector  $\mathbf{x}$  for the system. For example, node one (the non-event), corresponds to  $\mathbf{x} = \mathbf{1}$  (i.e. all components working). Different nodes in the EON correspond to instances where different event streams or component failures have occurred and each node has a different and unique event stream leading to it. Uniqueness refers to the events that have occurred thus far, and not necessarily the order they occur in. For example,  $E1, E2, E3 \equiv E2, E1, E3$ , and both of these event streams correspond to the failure of components one, two, and three. If the set of events corresponding to a specific node was not unique, then the EON would contain redundant nodes. Thus, every node in the EON has a unique state vector associated with it. Hence, for each node, there is a unique associated state vector  $\mathbf{x} = [x_j]$ ,  $j = 1, \dots, n$ , such that

$$x_j = \begin{cases} 1 & \text{if event } j \text{ has not occurred} \\ 0 & \text{if event } j \text{ has occurred.} \end{cases}$$

General  $k$  out of  $n$  System:

From before, it is known that any coherent system can equivalently be represented as a  $k$  out of  $n$  system [3], [25]. The  $k$  out of  $n$  system is the most general form that exists for coherent systems and its structure can be used to prove these results for any given system. Thus these results hold true for any coherent system. Recall that for any  $k$  out of  $n$  system, with  $1 \leq k \leq n$

$$\phi(\mathbf{x}) = \begin{cases} 1 & \text{if } \sum_{i=1}^n x_i \geq k \\ 0 & \text{if } \sum_{i=1}^n x_i < k. \end{cases}$$

1. *Node one - first intermediate node*

If at node one (the non-event) then

$$\begin{aligned} \sum_{i=1}^n x_i &= n \text{ since } \mathbf{x} = \mathbf{1} \\ \Rightarrow \phi(\mathbf{x}) &= 1. \end{aligned}$$

Thus, node one represents a path vector for the system.

Alternatively if  $\mathbf{x}$  is a path vector for this RBD such that  $\mathbf{x} = \mathbf{1}$ , then no events have occurred and this path vector is associated with node one, the first intermediate node.

2. *Any intermediate node*

Now suppose that an event stream occurs leaving the system at any intermediate

node in the EON, this occurs when

- $\Leftrightarrow$  no concluding events have occurred
- $\Leftrightarrow$  other events can still occur
- $\Leftrightarrow$  system is still functioning
- $\Leftrightarrow \phi(\mathbf{x}) = 1$
- $\Leftrightarrow$  this node represents a path vector for the system

Thus any intermediate node in the EON corresponds to a path vector in the RBD and any path vector in the RBD corresponds to an intermediate node in the EON.

### 3. *Any terminating node*

Similarly, suppose an event stream has occurred that leaves the system at any terminating node, this occurs when

- $\Leftrightarrow$  a concluding event has occurred
- $\Leftrightarrow$  no other events can occur
- $\Leftrightarrow$  system is in a failed state
- $\Leftrightarrow \phi(\mathbf{x}) = 0$
- $\Leftrightarrow$  this node represents a cut vector for the system.

Thus any terminating node in the EON corresponds to a cut vector in the RBD and any cut vector in the RBD corresponds to a terminating node in the EON.

Therefore it can be concluded, for any  $k$  out of  $n$  system, i.e. any coherent system, an intermediate node in an EON corresponds to a path vector in the associated RBD and a terminating node in an EON corresponds to a cut vector in the associated RBD. Likewise, it can definitively be claimed that a path (cut) vector in a RBD corresponds to an intermediate (terminating) node in the associated EON.

*3.2.2 Algorithm.* Having shown that any coherent system can be represented as an EON, the algorithm describing how to do so is now given. It is important to note that the main contribution of the algorithm and code (Appendix B) is that it produces all of the path and cut vectors for a given system. This is equivalent to deriving all of the event streams in the corresponding EON. In order for the algorithm to be used all of the system's minimal cut sets must be apriori. There has been much work in the area of minimal cut set algorithms with little agreement on an optimal cut set algorithm [5]. For this reason, this thesis does not include a specific minimal cut set algorithm within the EON reliability algorithm.

### Algorithm

1. Find all of the minimal cut sets for the RBD.
2. Use the minimal cut sets and boolean algebra to generate all of the possible path and cut vectors for the system. The `Matlab`<sup>®</sup> code to do this is shown in Appendix B.
  - (a.) Form  $\mathbf{V}$ , a matrix that contains exactly one row for each minimal cut set. If there are  $m$  minimal cut sets and the system has  $n$  components, then  $\mathbf{V}$  has size  $m \times n$ . Each row in  $\mathbf{V}$  is made up of ones and zeros. A "1" in row  $i$ , column  $j$ , means that the  $j^{th}$  component is an element of the  $i^{th}$  minimal cut set. These are the minimal cut vectors for the system.
  - (b.) Generate all possible state vectors of dimension  $n$  ( $n = \text{no. of components}$ ).
  - (c.) Compare each state vector with each of the minimal cut sets for the system in-turn, using boolean algebra (AND operations).
  - (d.) If any of the resultant vectors from the previous step is all zero's then that particular state vector is a cut vector. This corresponds to a terminating node. Otherwise this particular vector is a path vector and corresponds to an intermediate node in the EON.

3. Use the path and cut vectors for the system to find the possible event streams for each tier of the system's EON.
  - (a.) If the event stream corresponds to a path vector then the last node in the stream is an intermediate node.
  - (b.) If the event stream corresponds to a cut vector then the last node in the stream is a terminating node.
4. Determine which tier the event stream (state vector) corresponds to.
  - (a.) If the sum of the components of a state vector is equal to  $n - j$  then that state vector corresponds to a node on the  $j^{\text{th}}$  tier. This means  $j$  events have occurred.
  - (b.) If the vector is a cut vector then it will have no arcs leaving it, going to descendent tiers (determined from previous step).

*3.2.3 Other Measures .* In addition to system reliability, EONs can be used to determine other reliability measures. The probability that a specific component or group of components will cause system failure, is easily computed via the associated event streams in the EON. Lastly, minimal cut sets are easily found via boolean algebra. Since, it was shown that event streams ending in terminating nodes correspond to cut vectors and their respective cut sets, minimal cut sets are determined by taking the union of the intersection of the events in every terminating stream.

For the purpose of this thesis the following notation will be used. Let  $G_i$  be the event that component  $i$  fails and  $E_i$  be the event occurrence time of this failure (event  $G_i$ ). Recall that  $P_i(t)$  denotes the probability of being at node  $i$  at time  $t$ . In addition, for clarity, assume the random variable  $T$  denotes the amount of time elapsed thus far. The following simple two-component examples should aid in clarifying this notation and how EONs can be used to determine system reliability.

### 3.3 Reliability of Simple Two Component Systems

Assume the system of interest is comprised of two independent components with exponential lifetime distributions. The associated lifetime distributions are given below.

pdf:

$$f_1(t) = \lambda_1 e^{-\lambda_1 t}$$

$$f_2(t) = \lambda_2 e^{-\lambda_2 t}$$

cdf:

$$F_1(t) = 1 - e^{-\lambda_1 t}$$

$$F_2(t) = 1 - e^{-\lambda_2 t}$$

Survivor Function:

$$S_1(t) = e^{-\lambda_1 t}$$

$$S_2(t) = e^{-\lambda_2 t}$$

The desired measure is the probability of the system functioning at time  $t$ ,  $S_T(t)$ , and the probabilities of failure at time  $t$  from each possible cause. Examples for both possible basic system arrangements, series and parallel, are given next.

*3.3.1 Series System.* This system fails when either of the components fail. The EON of this system is shown in Figure 6 on the following page.

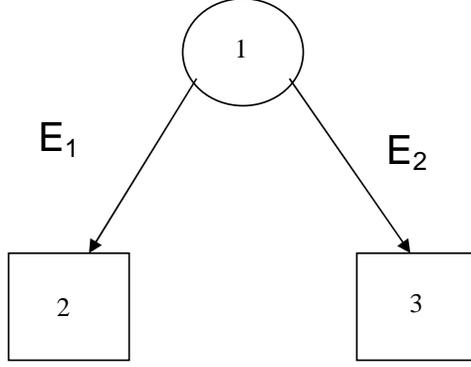

Figure 6: EON of 2 Components in Series

The probability that component one causes the failure by time  $t$ , is the probability of being at node two at time  $t$ ,  $P_2(t)$ , or

$$\begin{aligned}
 P\{E_1 < E_2 | T \leq t\} &= \int_0^t P\{E_1 < E_2 | E_1 = x\} f_{E_1}(x) dx \\
 &= \int_0^t P\{E_2 > x\} f_{E_1}(x) dx \\
 &= \lambda_1 \int_0^t e^{-(\lambda_1 + \lambda_2)x} dx \\
 &= \left( \frac{\lambda_1}{\lambda_1 + \lambda_2} \right) (1 - e^{-(\lambda_1 + \lambda_2)t}).
 \end{aligned}$$

Similarly, the probability that component two causes the failure by time  $t$ , which is the probability of being at node three by time  $t$ ,  $P_3(t)$ , is

$$\begin{aligned}
 P\{E_2 < E_1 | T \leq t\} &= \int_0^t P\{E_2 < E_1 | E_2 = y\} f_{E_2}(y) dy \\
 &= \int_0^t P\{E_1 > y\} f_{E_2}(y) dy \\
 &= \lambda_2 \int_0^t e^{-(\lambda_1 + \lambda_2)y} dy \\
 &= \left( \frac{\lambda_2}{\lambda_1 + \lambda_2} \right) (1 - e^{-(\lambda_1 + \lambda_2)t}).
 \end{aligned}$$

To calculate the system survival at time  $t$ ,  $S_T(t)$ , the complement of the sum of the previous two expressions is taken.

$$\begin{aligned}
S_T(t) &= 1 - (P_2(t) + P_3(t)) \\
&= 1 - (P\{E_1 < E_2 | T \leq t\} + P\{E_2 < E_1 | T \leq t\}) \\
&= 1 - P\{E_1 < E_2 | T \leq t\} - P\{E_2 < E_1 | T \leq t\} \\
&= 1 - \left(\frac{\lambda_1}{\lambda_1 + \lambda_2}\right) (1 - e^{-(\lambda_1 + \lambda_2)t}) - \left(\frac{\lambda_2}{\lambda_1 + \lambda_2}\right) (1 - e^{-(\lambda_1 + \lambda_2)t}) \\
&= 1 - \left(\frac{\lambda_1}{\lambda_1 + \lambda_2}\right) - \left(\frac{\lambda_2}{\lambda_1 + \lambda_2}\right) + \left(\frac{\lambda_1}{\lambda_1 + \lambda_2} + \frac{\lambda_2}{\lambda_1 + \lambda_2}\right) e^{-(\lambda_1 + \lambda_2)t}.
\end{aligned}$$

Which simplifies to

$$\begin{aligned}
&= 1 - 1 + e^{-(\lambda_1 + \lambda_2)t} \\
&= e^{-(\lambda_1 + \lambda_2)t}.
\end{aligned}$$

This is equivalent to finding the probability that both components are functioning, or the probability of being at node one (the non-event) at time  $t$ ,

$$\begin{aligned}
S_T(t) &= P_1(t) \\
&= P\{E_1 > t, E_2 > t\} \\
&= P\{E_1 > t\}P\{E_2 > t\} \\
&= e^{-(\lambda_1 + \lambda_2)t}.
\end{aligned}$$

This RBD can also be modeled as a continuous time markov chain (CTMC), and the probabilities found using standard CTMC techniques. For example, let  $X(t)$  denote the status of the system at time  $t$ , and  $\mathcal{S}$  denote the sample space for  $X(t)$ .

$$\mathcal{S} = \{0, 1, 2\},$$

where “0” represents the state where no components have failed, “1” represents the state where component one has failed and the system is failed, and “2” represents the state where component two has failed and the system is failed. The rate at which the system jumps from state  $i$  to state  $j$  is  $q_{ij}$ . The  $q_{ij}$ ’s make up the infinitesimal generator matrix  $\mathbf{Q}$ , such that

$$\mathbf{Q} = \begin{cases} q_{ij} & \text{if } i \neq j \\ -\sum_j q_{ij} & \text{if } i = j. \end{cases}$$

The conditional probabilities,  $p_{ij}(t)$ , associated with this process are the measures of interest. Where

$$p_{ij}(t) = P\{X(t) = j | X(0) = i\}$$

and  $\mathbf{P}(t)$ , the transition probability matrix, is made up of the  $p_{ij}(t)$ ’s for all  $i$  and  $j$ .  $\mathbf{P}(t)$  is found via solving the the Chapman-Kolmogorov differential equations,

$$\frac{d\mathbf{P}(t)}{dt} = \mathbf{P}(t)\mathbf{Q}.$$

The solution to this system of equations is given by

$$\mathbf{P}(t) = e^{\mathbf{Q}t} = \sum_{n=0}^{\infty} \frac{(\mathbf{Q}t)^n}{n!},$$

with initial condition  $\mathbf{P}(0) = \mathbf{I}$  [22].

The above equation is not easy to solve, even through the use of approximation techniques and doing so is both timely and computationally expensive. This is why, as stated in Section 1.3, a CTMCs long-term behavior is typically analyzed. To see this technique more specifically suppose  $\lambda_1 = 1$ , and  $\lambda_2 = 2$ . Then,

$$\mathbf{Q} = \begin{bmatrix} -3 & 1 & 2 \\ 0 & 0 & 0 \\ 0 & 0 & 0 \end{bmatrix}.$$

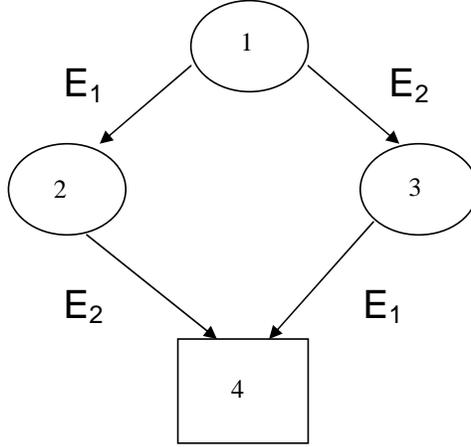

Figure 7: EON of 2 Components in Parallel

Using Matlab<sup>®</sup>

$$\mathbf{P}(t) = \begin{bmatrix} e^{-3t} & -\frac{1}{3}e^{-3t} + \frac{1}{3} & -\frac{2}{3}e^{-3t} + \frac{2}{3} \\ 0 & 1 & 0 \\ 0 & 0 & 1 \end{bmatrix}.$$

From  $\mathbf{P}(t)$  it is easy to pull off the performance measures that were found above using EONs. However, finding these performance measures with EONs was much simpler and computationally inexpensive. This observation becomes more evident as the coherent structures become more complicated.

*3.3.2 Parallel System.* The EON of this system is shown in Figure 7. The probability that the system is not functioning at time  $t$  is the probability that both components have failed, or the probability of being at node four, by that time.

Mathematically the probability that both components have failed by time  $t$  is

$$\begin{aligned} P_4(t) &= P\{E_1 < t, E_2 < t\} \\ &= P\{E_1 < t\}P\{E_2 < t\} \\ &= (1 - e^{-\lambda_1 t}) (1 - e^{-\lambda_2 t}) \\ &= 1 - e^{-\lambda_1 t} - e^{-\lambda_2 t} + e^{-(\lambda_1 + \lambda_2)t}. \end{aligned}$$

Now to calculate system survival, the probability of being at node one, two, or three at time  $t$  is derived;

$$\begin{aligned}
S_T(t) &= P_1(t) + P_2(t) + P_3(t) \\
&= P\{E_1 > t, E_2 > t\} + P\{E_1 < t, E_2 > t\} + P\{E_1 > t, E_2 < t\} \\
&= P\{E_1 > t\}P\{E_2 > t\} + P\{E_1 < t\}P\{E_2 > t\} + P\{E_1 > t\}P\{E_2 < t\} \\
&= e^{-(\lambda_1+\lambda_2)t} + (1 - e^{-\lambda_1 t})e^{-\lambda_2 t} + (1 - e^{-\lambda_2 t})e^{-\lambda_1 t} \\
&= e^{-\lambda_1 t} + e^{-\lambda_2 t} - e^{-(\lambda_1+\lambda_2)t}.
\end{aligned}$$

This is equivalent to the complement of the expression found for the system not functioning at time  $t$ .

### ***3.4 Non-Repairable Systems Methodology Summary***

The primary strength of EONs in reliability theory is the all-inclusive, intuitive, graphical nature of the EON structure. This chapter showed how EONs can be used in reliability theory in calculating many different reliability measures in an efficient manner. This chapter showed the methodology of the technique, followed by a proof showing that EONs can be derived for any coherent system. Next, an algorithm providing steps of how to develop the associated EON for any coherent system was given. To demonstrate the techniques introduced in this chapter, some simple examples were given. In these examples the components were assumed to have exponentially distributed lifetimes so that an exact analytical expression could be derived for system reliability. Next, more difficult, but at the same time more realistic systems are analyzed; those comprised of repairable components.

## IV. EONs and Availability

### 4.1 Methodology Overview for Repairable Systems

If concerned with modeling repairable systems, then the aforementioned event occurrence network (EON) alone will not allow for the calculation of availability measures. The underlying probability model has changed, thus the graphical structure must change to reflect this. The graphical structure for this type of system will be referred to as an *availability graph*.

**Availability Graph:** graphical structure used to represent repairable systems.

This chapter first discusses the details and qualities of an availability graph and analyzes the probabilistic model that describes it. The first methodology section makes use of some simplifying assumptions to reduce the complexity of repairable systems. In this section some basic examples are given to demonstrate how EONs can still be used to model systems with repairable components, once these assumptions are made. In the second methodology section the number of assumptions are reduced and a more robust algorithm is devised to better handle all of the important availability measures.

### 4.2 Methodology

The underlying probabilistic model, now represents the superposition of several *non-terminating* counting processes and due to the repair times, the counting processes are *no longer independent*. In this model, the counting processes do not terminate, because the system can go from non-functioning to functioning with the repair of a component or group of components. More specifically the probabilistic model now represents the superposition of several alternating renewal processes. As in reliability, there is still a group for each component in the system, but now each group consists of an infinite series of sequential alternating component failure and repair events. In this case, events between groups can no longer occur independently,

because a specific component failure may cause the system to fail and this failure will inhibit all other events from other groups from occurring. If this is the case, then the only possible next event that can occur is that of the specific component's repair.

If a couple of simplifying assumptions are made, then EONs, in the classical sense, can still be used. The first assumption is that the components and the system itself are repaired to a *good as new* state. This assumption allows the process to start over when a component is repaired, not allowing for components that have not yet failed to accrue time. In other words, every component is modeled as new when the component causing system failure is repaired. Obviously this is a large practical limitation and will be dealt with later in this thesis. For the second assumption, the counting processes must terminate after some specified amount of time or number of failures, i.e. the process is estimated with a finite, terminating counting process. Additionally, as was the case in repairable systems, assume that when the system is down no other failures or repairs can take place. If these assumptions are made, then EONs can be used to model the availability of each component separate from the system and component availability can be estimated using piecewise polynomial approximation. Also, assuming that the failure and repair times are independent of one another (a typical assumption for repairable systems), the availabilities of each component can be treated as discrete probabilities and then used to find system availability at time  $t$ . EONs and piecewise polynomial approximation, for these types of systems, are only valuable when component life or repair times are not exponentially distributed. Otherwise CTMCs or Equation (4) can be used to find each components respective availability exactly. The analysis shown in this chapter utilizes the explicit solutions found via exponentially distributed life and repair times so that the techniques and approximations found within can be validated.

Examples of systems with repairable components and calculations of different availability measures for these systems are now given. Using slightly different notation from Chapter 3, let  $G_{ij}$  be the event that component  $i$  fails for the  $j^{th}$  time and  $E_{ij}$  be the event occurrence time of this failure (event  $G_{ij}$ ), where  $i = 1, \dots, n$  and

$j = 1, \dots, m$ . The indices are used to represent both the component ( $i$ ) and the number of times it has failed ( $j$ ). In addition to the failure events there are now repair events as well. Thus, let  $H_{ij}$  represent the event that component  $i$  is repaired for the  $j^{th}$  time and  $R_{ij}$  denote component  $i$ 's,  $j^{th}$  repair completion (occurrence) time. In this notation  $E$  and  $R$  denote a component's failure and repair events respectively. Additionally,  $A_{sys}(t)$  gives the system's instantaneous availability at time  $t$ , while  $A_i(t)$  gives the instantaneous availability for component  $i$  at time  $t$ .

*4.2.1 Availability of a Simple One Component System .* Assume that the system of interest is comprised of one component that is repairable. If both the component life and repair times are exponentially distributed then, from equation (4), system availability at any time  $t$  can be calculated explicitly (reference Section 2.11). This system is an alternating renewal process and its availability can be modeled and estimated by an EON and piecewise polynomial approximation. Theoretically the probabilistic model for this system is an infinite series of alternating functioning and failed states. In order to use an EON coupled with piecewise polynomial approximation to approximate the availability of this system the sequence must terminate at some specified point, denoted by node  $n$ , since EONs model terminating counting processes [12] (see Figure 8 on the following page). The more nodes, or events used the more accurate the availability approximation will be. The last node in this system can be thought of as the *final* failure, or where our approximation ends. If the number of nodes in this approximation were infinite then the approximation will be exact. In other words, if  $A_{EON}(t)$  denotes the approximated availability using an EON coupled with piecewise polynomial approximation and  $n$  denotes the number of nodes in the EON approximation, then

$$\lim_{n \rightarrow \infty} A_{EON}(t) = A(t).$$

The odd numbered nodes in the EON represent times when the system or component is not in a failed state, while the even numbered nodes represent times when the component is in a failed state and being repaired. Thus, system availability can be

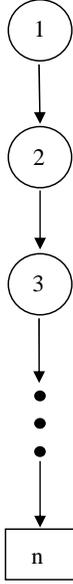

Figure 8: EON of System With One Repairable Component

estimated by summing the probabilities of all of the odd numbered nodes at time  $t$ . Using the EON approximation, the last node,  $n$ , will *collect* the remainder of the probability, thus skewing the results slightly, depending on whether it is an even (failure) or odd (repair) numbered node.

As an example assume that a system identical to the one described above is analyzed with the following parameters:

$$\lambda \text{ (failure rate)} = 1 \text{ (per hour) and}$$

$$\mu \text{ (repair rate)} = \frac{1}{2} \text{ (per hour).}$$

Instantaneous availability for this system is calculated using an EON with one event group and 48 events (nodes): 24 representing system availability; and 24 representing system unavailability. The series terminates at node number 48, representing a failed system, and the remainder of the system probability is consolidates there. To approximate the availability for this system, piecewise polynomials are used. More

Table 1: Actual vs. Estimated Instantaneous Availability via EONs

$t$	$A(t)$	$A_{EON}(t)$
0	1	1
1	0.482086773	0.479624447
2	0.366524712	0.362068425
3	0.340739331	0.336790917
4	0.334985835	0.331493226
5	0.333702056	0.330445695
6	0.333415607	0.330104113
7	0.333351691	0.329574885
8	0.333337429	0.329940456
9	0.333334247	0.330253842
10	0.333333537	0.330636263

specifically, the computer code written by Denhard [12], is used. As a comparison, the average as opposed to instantaneous, availability of this system was estimated using Raptor<sup>®</sup> version 6.0, a widely used reliability software package. Calculating a system's instantaneous availability via Raptor<sup>®</sup> is not straight-forward. Despite this discrepancy, the results still produce a fair comparison, because exact analytical solutions can be found for both instantaneous and average availability in the case of exponentially distributed life and repair times. Additionally, in the case of exponentially distributed life and repair times,  $\lim_{t \rightarrow \infty} A(t) = \lim_{c \rightarrow \infty} A_c = A$  (Section 2.11), thus both measures are approaching the same number,  $A = \frac{1}{3}$ . In this case average availability was approximated by taking the mean average availability from 100 replications of the system from time 0 to  $c$ . Since the failure and repair times are exponentially distributed, average and instantaneous availabilities can be calculated exactly using the results found in equations (4) and (5). The actual and estimated instantaneous availabilities using EONs and piecewise polynomial approximation for this system, for different times, are shown in Table 1. Similarly the actual and estimated average availabilities using Raptor<sup>®</sup>, for different intervals, are shown in Table 2 on the next page.

As can be seen from Tables 1 and Table 2, estimating availability measures via these methods produces fairly accurate results. Note from Table 1, that  $A_{EON}(t) <$

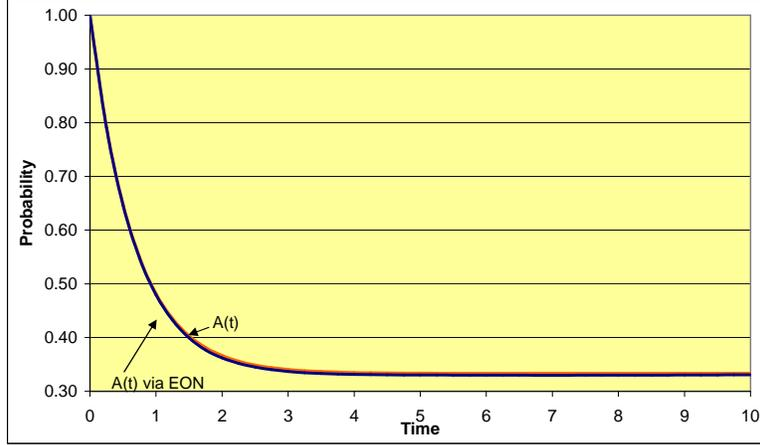

Figure 9: Actual vs. Estimated Instantaneous Availability via EON

Table 2: Actual vs. Estimated Average Availability via Raptor

$c$	$A_c$	$A_{\text{Rap}}$
0	1.0000000	1.0000000
1	0.6786088	0.6678013
2	0.5444918	0.5379340
3	0.4798357	0.4797897
4	0.4441690	0.4401924
5	0.4221731	0.4202572
6	0.4073983	0.4167049
7	0.3968236	0.4178025
8	0.3888885	0.4535390
9	0.3827160	0.4117084
10	0.3777778	0.3890766

$A(t)$  this is due to the fact that the approximation ended in a failed state (node 48), thus the results are skewed slightly in favor of system unavailability. Graphs of these approximations versus the actual instantaneous and average availabilities are shown in Figures 9 and 10, respectively. It is apparent, that estimates produced from piecewise polynomial approximation and EONs are very accurate with the largest error being 0.0046072. Simulation via Raptor<sup>®</sup> produces errors a magnitude larger, with the largest from this example being 0.0646505. It should be noted that as time goes on simulation produces more accurate results, but overall the approximation techniques using EONs, especially in the short-term, provide better estimates of availability.

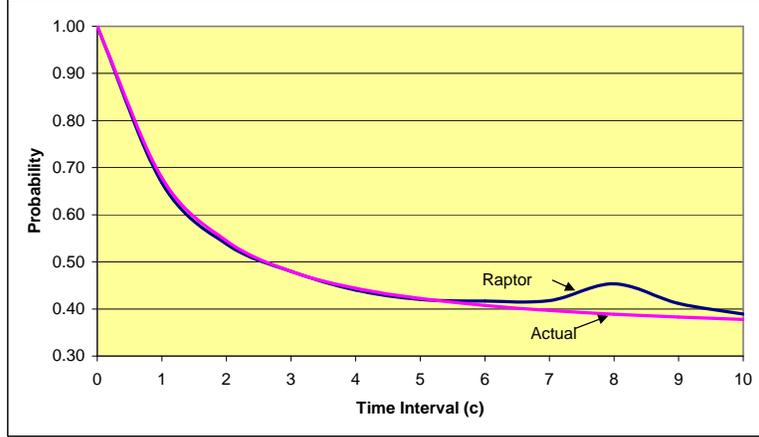

Figure 10: Actual vs. Estimated Average Availability via Raptor

*4.2.2 Availability of Three Component Systems.* The system of interest now consists of three repairable components in some particular configuration. To allow for a comparison with actual (instantaneous) availability, assume also that the failure and repair times of each component  $i$  are exponentially distributed with rate  $\lambda_i$  and  $\mu_i$  respectively. This allows for an analytical exact computation of component availability to be used in calculating the system's availability.

*4.2.2.1 Series System.* For this example the system of interest consists of three repairable components in series. Conceptually, a probabilistic model for this system is an infinite repeating subsystem of nodes, and can be approximated via a finite repeating subsystem of nodes, like the one shown in Figure 11 on the following page.

However, the typical EON representation will not work in approximating this case, because it allows for infeasible event streams (e.g.  $E_{11}, E_{21}, E_{31}, R_{11}$  etc.). This is because the independence assumption between event groups in an EON is no longer valid. Many event streams are not feasible, because once a component fails, the system does not function again until the failed component is repaired. In other words, other components cannot fail during this time. The availability for this system,  $A_{sys}(t)$ , is found by analyzing component availability,  $A_i(t)$ , as it relates to the system configu-

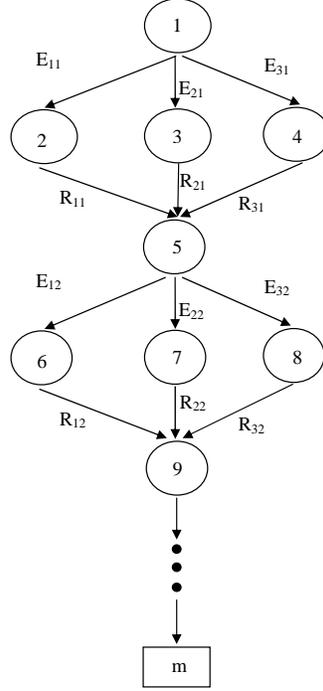

Figure 11: Availability Graph for 3 Repairable Components in Series

ration, at a particular time  $t$ . In other words for this particular system,

$$A_{sys}(t) = \prod_{i=1}^3 A_i(t),$$

where  $A_i(t)$  is derived for each component at time  $t$  analytically (using equation (4) since times are exponentially distributed), or estimated using an EON and piecewise polynomial approximation. Each component's availability will be found as was done in the simple one component system above, in Section 4.2.1. To show the accuracy of the EON and piecewise polynomial approximation method, both techniques will be utilized and the results compared. Thus, for this system

$$A_{sys}(t) = \prod_{i=1}^3 \left[ \left( \frac{\lambda_i}{\lambda_i + \mu_i} \right) e^{-(\lambda_i + \mu_i)t} + \left( \frac{\mu_i}{\lambda_i + \mu_i} \right) \right].$$

Table 3: Actual Availability for 3 Component Series System

$t$	$A_1(t)$	$A_2(t)$	$A_3(t)$	$A_{sys}(t)$
0	1.0000000000000000	1.0000000000000000	1.0000000000000000	1.0000000000000000
1	0.645903118621619	0.816416999724780	0.952630834209485	0.502347279940387
2	0.584370307180994	0.801347589399817	0.952382263640445	0.445985125447514
3	0.573677507885363	0.800110616874030	0.952380959261811	0.437148064797317
4	0.571819377985238	0.800009079985952	0.952380952417060	0.435676851921384
5	0.571496483425050	0.800000745330634	0.952380952381142	0.435426297803778
6	0.571440372764007	0.800000061180464	0.952380952380953	0.435383174449708
7	0.571430622193168	0.800000005021998	0.952380952380952	0.435375714880246

Now suppose that the specific components in this system have the following parameters:

$$\lambda_1 = .75 \quad \lambda_2 = .5 \quad \lambda_3 = .25$$

$$\mu_1 = 1 \quad \mu_2 = 2 \quad \mu_3 = 5.$$

Using this method and the parameters above, the actual availability of this system and its components for different values of  $t$  is shown in Table 3. The estimated availability is shown in Table 4 on the following page. Once again component availabilities are skewed slightly in favor of unavailability, since the EON approximation ends at a node representing a failed state. Clearly, approximating a system's availability using the EON method and piecewise polynomial approximation produces very accurate results with errors that are relatively small (shown in Table 5 on the next page). Graphs of the actual versus estimated availabilities for this system are shown in Table 12 on the following page. Note, from Table 5 that the error seems to grow with time  $t$ , this is because both the actual and estimated availability are approaching the system's limiting availability. As time goes on both the actual and approximated instantaneous availability will reach an asymptotic value, and thus the error will remain constant. The table alone can be misleading, and as can be seen in Figure 12, the error has reached its largest value and will not continue to grow by time  $t = 7$ .

*4.2.2.2 Parallel System.* Next look at a parallel system, using the same parameters as those used in the previous three component series system. The EON

Table 4: Estimated Availability for 3 Component Series System Using EON

$t$	$A_1(t)$	$A_2(t)$	$A_3(t)$	$A_{sys}(t)$
0	1.0000000000000000	1.0000000000000000	1.0000000000000000	1.0000000000000000
1	0.644519299022326	0.815201897481508	0.955272217508395	0.501912781242280
2	0.582932069599997	0.801250447090181	0.955697507796866	0.446382013389881
3	0.574020368799340	0.803736893153764	0.958890761373812	0.442395134085091
4	0.573372432396805	0.805739664833655	0.962237267474981	0.444542947809599
5	0.573882995273686	0.806735306728708	0.962422871551706	0.445574528148476
6	0.575176945093117	0.807797897617949	0.962224230146017	0.447075094697202
7	0.576000973011723	0.808893854858888	0.962051244306088	0.448242424792374

Table 5: Errors for Series System Availability

$t$	Error
0	0.0000000000000000
1	0.000434498698107
2	0.000396887942367
3	0.005247069287773
4	0.008866095888215
5	0.010148230344698
6	0.011691920247494
7	0.012866709912128

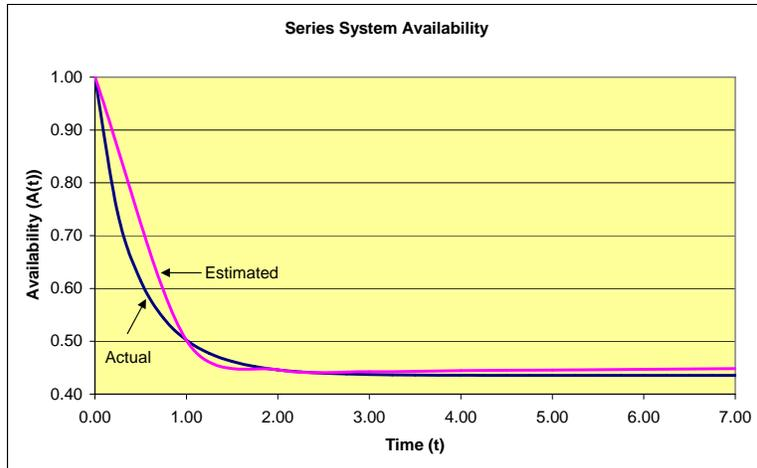

Figure 12: Actual vs. Estimated Instantaneous Availability via EON for Series System

Table 6: Actual Availability for 3 Component Parallel System

$t$	$A_1(t)$	$A_2(t)$	$A_3(t)$	$A_{sys}(t)$
0	1.0000000000000000	1.0000000000000000	1.0000000000000000	1.0000000000000000
1	0.645903118621619	0.816416999724780	0.952630834209485	0.996920712056687
2	0.584370307180994	0.801347589399817	0.952382263640445	0.996068401579742
3	0.573677507885363	0.800110616874030	0.952380959261811	0.995942032016772
4	0.571819377985238	0.800009079985952	0.952380952417060	0.995922274454096
5	0.571496483425050	0.800000745330634	0.952380952381142	0.995919029336293
6	0.571440372764007	0.800000061180464	0.952380952380953	0.995918480989156
7	0.571430622193168	0.800000005021998	0.952380952380952	0.995918386980519

approximation for this system is a finite repeating subsystem of nodes, represented in cycles, shown in Figure 13 on the next page (note the actual system would be an infinite series). The generic notation  $X_{ij}$  represents the time to failure or repair of node  $i$  for the  $j^{th}$  time, depending on which way the arc is followed. If moving downward in the EON then  $X_{ij} = E_{ij}$  and similarly if moving upwards then  $X_{ij} = R_{ij}$ . The component availabilities are computed in the same manner and results are obviously identical to those in Tables 3 on page 59 and 4 on the page before. The system's availability is however computed slightly differently, and is

$$\begin{aligned}
 A_{sys}(t) &= 1 - \prod_{i=1}^3 (1 - A_i(t)) \\
 &= 1 - \prod_{i=1}^3 \left( 1 - \left[ \left( \frac{\lambda_i}{\lambda_i + \mu_i} \right) e^{-(\lambda_i + \mu_i)t} + \left( \frac{\mu_i}{\lambda_i + \mu_i} \right) \right] \right).
 \end{aligned}$$

Using this equation the results shown in Table 6 are derived. Now using the EON approach, system availability at different times is given in Table 7 on the next page. This approximation has small relative error as well (Table 8 on the following page). Plots showing the difference between actual and estimated availability for this system are shown in Figure 14 on page 63. Once again both the actual and estimated instantaneous availabilities are approaching the system's limiting availability as  $t$  grows, thus the error between the two is also approaching a finite number and will not continue to grow.

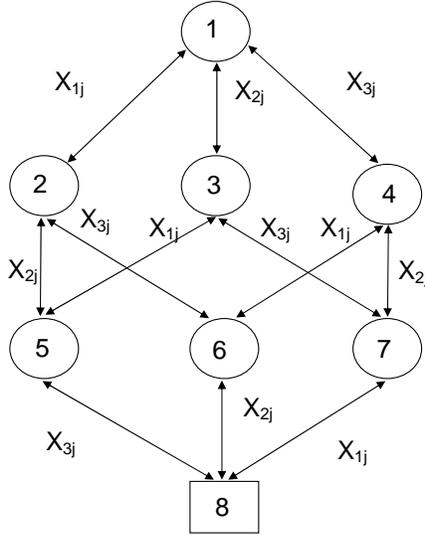

Figure 13: Availability Graph for 3 Repairable Components in Parallel

Table 7: Estimated Availability for 3 Component Parallel System Using EON

$t$	$A_1(t)$	$A_2(t)$	$A_3(t)$	$A_{sys}(t)$
0	1.0000000000000000	1.0000000000000000	1.0000000000000000	1.0000000000000000
1	0.644519299022326	0.815201897481508	0.955272217508395	0.997061735399832
2	0.582932069599997	0.801250447090181	0.955697507796866	0.996327674949925
3	0.574020368799340	0.803736893153764	0.958890761373812	0.996563099683737
4	0.573372432396805	0.805739664833655	0.962237267474981	0.996870345030053
5	0.573882995273686	0.806735306728708	0.962422871551706	0.996905396754085
6	0.575176945093117	0.807797897617949	0.962224230146017	0.996915537210786
7	0.576000973011723	0.808893854858888	0.962051244306088	0.996925057121163

Table 8: Errors for Parallel System Availability

$t$	Error
0	0.0000000000000000
1	0.000141023343146
2	0.000259273370184
3	0.000621067666964
4	0.000948070575957
5	0.000986367417792
6	0.000997056221630
7	0.001006670140644

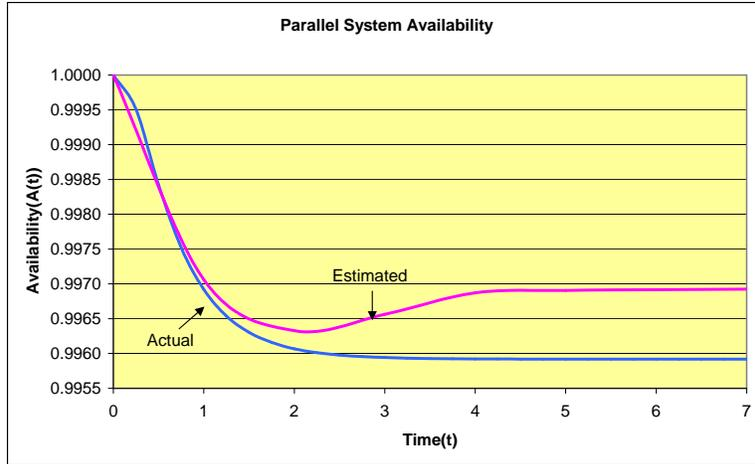

Figure 14: Actual vs. Estimated Instantaneous Availability via EON for Parallel System

### 4.3 Methodology with Fewer Simplifying Assumptions

In the previous methodology section it was necessary to assume that the entire system was repaired to a *good as new* state with the repair of a single component. This assumption is now removed so that availability graphs can be used to model systems in a more realistic manner. Due to this system's complexity, a limit must be placed on the number of failures and repairs that are allowed to take place, which means that the availability measures calculated are estimates for the real system availability. In other words the infinite non-terminating counting process is estimated with a finite terminating process. It should be mentioned that this assumption more closely models real-world systems, since an infinite number of failures and repairs is unrealistic.

Additionally, some other assumptions are necessary. First, assume that the components do not fail or age (wear) when the system is in a failed state. Second, assume that the components are repaired to a *good as new* state. Last, once again, failure and repair times are assumed to be independent of one another.

The following example goes to show the complexity of systems of this type. Suppose that the system of concern is made up of one repairable component. The system is limited to only one repair, the availability graph for this system is shown

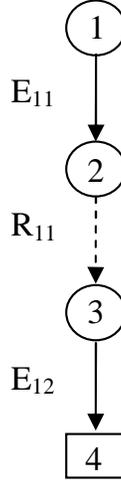

Figure 15: Availability Graph for a Repairable Component (One Repair)

in Figure 15. The dashed arcs in this representation (availability graphs), represent times when the system is undergoing repair.

Once again to ensure the integral expressions for the nodal probabilities are tractable in a closed form assume that the component's life and repair time are exponentially distributed with rates  $\lambda_1$  and  $\mu_1$  respectively. These probabilities for a specific time  $t$  are calculated below. In this availability graph node one represents the case where the component has yet to fail by time  $t$ ,

$$P_1(t) = P \{E_{11} > t\} = e^{-\lambda_1 t}.$$

Node two is the event where the component has failed once and has not yet been repaired (under-going repair), by time  $t$ ,

$$P_2(t) = P \{E_{11} < t, E_{11} + R_{11} > t\}.$$

Conditioning on  $E_{11}$  yields

$$\begin{aligned}
&= \int_0^t P\{R_{11} > t - x\} f_{E_{11}}(x) dx \\
&= \int_0^t (e^{-\mu_1(t-x)}) \lambda_1 e^{-\lambda_1 x} dx \\
&= \lambda_1 e^{-\mu_1 t} \int_0^t e^{(\mu_1 - \lambda_1)x} dx \\
&= \left( \frac{\lambda_1 e^{-\mu_1 t}}{\mu_1 - \lambda_1} \right) (e^{(\mu_1 - \lambda_1)t} - 1) \\
&= \left( \frac{\lambda_1}{\mu_1 - \lambda_1} \right) (e^{-\lambda_1 t} - e^{-\mu_1 t}).
\end{aligned}$$

Node three represents the event stream where the component has failed and been repaired by time  $t$ ,

$$\begin{aligned}
P_3(t) &= P\{E_{11} + R_{11} < t, E_{11} + R_{11} + E_{12} > t\} \\
&= \int_0^t P\{E_{12} > t - x\} f_{E_{11} + R_{11}}(x) dx \quad (\text{hypo-exponential}) \\
&= \int_0^t (e^{-\lambda_1(t-x)}) \left( \frac{\lambda_1 \mu_1}{\lambda_1 - \mu_1} \right) (e^{-\mu_1 x} - e^{-\lambda_1 x}) dx \\
&= \left( \frac{\lambda_1 \mu_1 e^{-\lambda_1 t}}{\lambda_1 - \mu_1} \right) \int_0^t e^{(\lambda_1 - \mu_1)x} - 1 dx \\
&= \left( \frac{\lambda_1 \mu_1 e^{-\lambda_1 t}}{\lambda_1 - \mu_1} \right) \left( \frac{e^{(\lambda_1 - \mu_1)t} - 1}{\lambda_1 - \mu_1} - t \right) \\
&= \left( \frac{\lambda_1 \mu_1}{\lambda_1 - \mu_1} \right) \left( \frac{e^{-\mu_1 t} - e^{-\lambda_1 t}}{\lambda_1 - \mu_1} - t e^{-\lambda_1 t} \right).
\end{aligned}$$

Lastly, node four represents the event stream where the component has failed for its second and final time by time  $t$ ,

$$\begin{aligned}
P_4(t) &= P \{E_{11} + R_{11} + E_{12} < t\} \\
&= \int_0^t P \{E_{12} < t - x\} f_{E_{11}+R_{11}}(x) dx \\
&= \int_0^t (1 - e^{-\lambda_1(t-x)}) \left( \frac{\lambda_1 \mu_1}{\lambda_1 - \mu_1} \right) (e^{-\mu_1 x} - e^{-\lambda_1 x}) \\
&= \left( \frac{\lambda_1 \mu_1}{\lambda_1 - \mu_1} \right) \int_0^t (e^{-\mu_1 x} - e^{-\lambda_1 x} - e^{-\lambda_1 t} e^{(\lambda_1 - \mu_1)x} + e^{-\lambda_1 t}) dx \\
&= \left( \frac{\lambda_1 \mu_1}{\lambda_1 - \mu_1} \right) \left( \frac{1 - e^{-\mu_1 t}}{\mu_1} + \frac{e^{-\lambda_1 t} - 1}{\lambda_1} + \frac{e^{-\lambda_1 t} - e^{-\mu_1 t}}{\lambda_1 - \mu_1} + t e^{-\lambda_1 t} \right).
\end{aligned}$$

To ensure that the expressions above are correct one can take their sum at any time  $t$ . Since the states of the nodes in the availability graph are collectively exhaustive and mutually exclusive, they should sum to one for any time  $t$ . To ensure that this is the case the sum of all the nodes is taken,

$$\begin{aligned}
&= P_1(t) + P_2(t) + P_3(t) + P_4(t) \\
&= e^{-\lambda_1 t} + \left( \frac{\lambda_1}{\mu_1 - \lambda_1} \right) (e^{-\lambda_1 t} - e^{-\mu_1 t}) + \left( \frac{\lambda_1 \mu_1}{\lambda_1 - \mu_1} \right) \left( \frac{e^{-\mu_1 t} - e^{-\lambda_1 t}}{\lambda_1 - \mu_1} - t e^{-\lambda_1 t} \right) \\
&\quad + \left( \frac{\lambda_1 \mu_1}{\lambda_1 - \mu_1} \right) \left( \frac{1 - e^{-\mu_1 t}}{\mu_1} + \frac{e^{-\lambda_1 t} - 1}{\lambda_1} + \frac{e^{-\lambda_1 t} - e^{-\mu_1 t}}{\lambda_1 - \mu_1} + t e^{-\lambda_1 t} \right). \\
&= \frac{e^{-\lambda_1 t} (\lambda_1^2 - 2\lambda_1 \mu_1 + \mu_1^2)}{(\lambda_1 - \mu_1)^2} + \frac{\lambda_1 (\lambda_1 - \mu_1) (e^{-\mu_1 t} - e^{-\lambda_1 t})}{(\lambda_1 - \mu_1)^2} \\
&\quad + \frac{\lambda_1 \mu_1 e^{-\mu_1 t} - \lambda_1 \mu_1 e^{-\lambda_1 t} - \lambda_1^2 \mu_1 t e^{-\lambda_1 t} + \lambda_1 \mu_1^2 t e^{-\lambda_1 t}}{(\lambda_1 - \mu_1)^2} \\
&\quad + \frac{\lambda_1^2 - 2\lambda_1 \mu_1 + \mu_1^2 - \lambda_1^2 e^{-\mu_1 t} - \mu_1^2 e^{-\lambda_1 t} + 2\lambda_1 \mu_1 e^{-\lambda_1 t} + \lambda_1^2 \mu_1 t e^{-\lambda_1 t} - \lambda_1 \mu_1^2 t e^{-\lambda_1 t}}{(\lambda_1 - \mu_1)^2}.
\end{aligned}$$

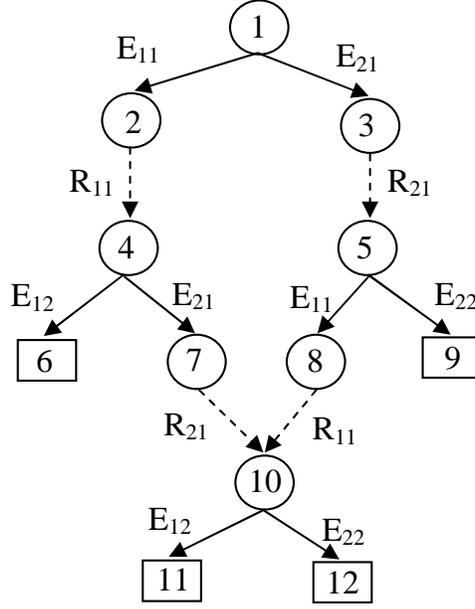

Figure 16: Availability Graph for 2 Repairable Components in Series (One Repair)

More simplification yields,

$$\begin{aligned}
&= \left( \frac{1}{(\lambda_1 - \mu_1)^2} \right) \left( \lambda_1^2 e^{-\lambda_1 t} - 2\lambda_1 \mu_1 e^{-\lambda_1 t} + \mu_1^2 e^{-\lambda_1 t} + \lambda_1^2 e^{-\mu_1 t} - \lambda_1^2 e^{-\lambda_1 t} - \lambda_1 \mu_1 e^{-\mu_1 t} \right. \\
&\quad + \lambda_1 \mu_1 e^{-\lambda_1 t} + \lambda_1 \mu_1 e^{-\mu_1 t} - \lambda_1 \mu_1 e^{-\lambda_1 t} - \lambda_1^2 \mu_1 t e^{-\lambda_1 t} + \lambda_1 \mu_1^2 t e^{-\lambda_1 t} + \lambda_1^2 - 2\lambda_1 \mu_1 + \mu_1^2 \\
&\quad \left. - \lambda_1^2 e^{-\mu_1 t} - \mu_1^2 e^{-\lambda_1 t} + 2\lambda_1 \mu_1 e^{-\lambda_1 t} + \lambda_1^2 \mu_1 t e^{-\lambda_1 t} - \lambda_1 \mu_1^2 t e^{-\lambda_1 t} \right) \\
&= \frac{\lambda_1^2 - 2\lambda_1 \mu_1 + \mu_1^2}{(\lambda_1 - \mu_1)^2} \\
&= 1.
\end{aligned}$$

Thus it can be certain that the above nodal probability expressions are correct.

Limitations to this method are that the number of nodes grow increasingly large as more system failures and repairs are allowed to take place, even for simple systems. As another example suppose that the system being modeled is a simple series arrangement of two repairable components. Allowing each component to be repaired only one time produces an availability graph with eleven nodes (Figure 16).

Figure 16, shows all of the possible events that can occur in this system. The dashed lines represent times when the system is in a failed state and non-failed components are not aging. Once again the terminating nodes, represent event streams that end in a concluding event. Now all that is left to do is to find the nodal probabilities, or the probability of being at a particular node  $i$  at time  $t$  ( $P_i(t)$ , for  $i = 1, \dots, 11$ ). Expressions for these probabilities turn out to be more difficult than one might imagine and doing so is left as an exercise in the following chapter.

#### ***4.4 Repairable Systems Methodology Summary***

This chapter provided an analysis of repairable systems. It began by analyzing repairable systems using EONs and piecewise polynomial approximation techniques. This can only be done when it is assumed that the process starts over when a component is repaired. This assumption does not allow for components that have not yet failed to accrue time. If this assumption is made then the instantaneous availability for each component can be approximated via EONs and finite terminating counting processes through piecewise polynomial approximation. These component availabilities are then used to find the system's instantaneous availability via techniques used in the reliability analysis of coherent systems. A few basic examples illustrated how the technique can be used and the accuracy of the results. The results are compared to ones produced via a trusted reliability software tool, Raptor<sup>®</sup> version 6.0, in order to demonstrate the efficiency of the given technique.

Following this, some of the simplifying assumptions were removed and a more robust methodology was introduced. This methodology allows for components that have not caused system failure to pick up where they left off when the system failed. This also makes the instantaneous availability much more difficult to capture. An example of this type of system is analyzed in the following chapter.

## V. Illustrations and Results

### 5.1 *Implementation Overview*

Specific examples using the methodologies introduced in Chapter 3 and 4 are discussed next. This discussion is divided into two main sections. The first section consists of examples of systems with non-repairable components. These examples validate the desirableness of event occurrences networks (EONs) in the field of reliability. The second section contains a specific example of a system with repairable components. All of the examples of systems in this chapter are comprised of components with exponentially distributed life and repair times. This is done so that exact solutions can be obtained. In the case of generally distributed failure and repair times an approximation technique is needed, one technique of which being piecewise-polynomial approximation.

### 5.2 *Reliability of Systems with Non-Repairable Components*

In dealing with systems made up of non-repairable components, the probability that the system is operating over a specified period of time is the system's reliability. EONs make the evaluation of many reliability measures easier than any of the existing methods. Specifically the system's reliability and the probability of system failure from each possible cause are easy to calculate using EONs.

*5.2.1 Reliability of Simple Three Component Series and Parallel Combination System.* Assume this system is made up of three components that have lifetimes described by the exponential distribution, where component  $i$ 's lifetime has rate  $\lambda_i$ ,  $i = 1, 2, 3$ . As was the case previously, the probability of the system functioning at time  $t$ ,  $S_T(t)$ , and the probabilities of system failure at time  $t$  from each possible cause are the measures of interest.

Suppose the first two components are in parallel, and they together are in series with the third. This system fails when components one and two fail or when compo-

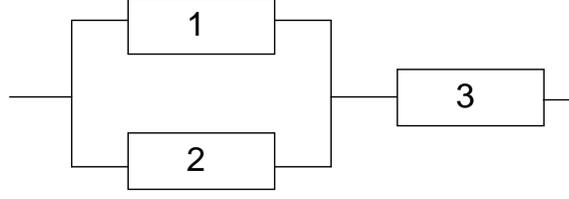

Figure 17: RBD of System with Components in Series and Parallel

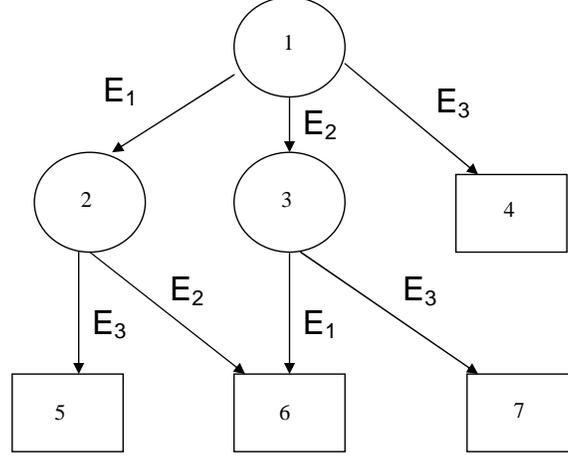

Figure 18: EON of System with Components in Series and Parallel

nent three fails. This system's reliability block diagram (RBD) is shown in Figure 17, and its EON in Figure 18.

The probability that the system fails due to components one and two failing is equivalent to the probability of being at node six at time  $t$ , or

$$\begin{aligned}
 P_6(t) &= P\{E_1 < E_2, E_2 < E_3 | T \leq t\} + P\{E_2 < E_1, E_1 < E_3 | T \leq t\} \\
 &= \int_0^t P\{E_1 < E_2, E_3 > E_2 | E_2 = x\} f_{E_2}(x) dx + \int_0^t P\{E_2 < E_1, E_3 > E_1 | E_1 = y\} f_{E_1}(y) dy \\
 &= \int_0^t P\{E_1 < x\} P\{E_3 > x\} f_{E_2}(x) dx + \int_0^t P\{E_2 < y\} P\{E_3 > y\} f_{E_1}(y) dy \\
 &= \lambda_2 \int_0^t (1 - e^{-\lambda_1 x}) e^{-(\lambda_2 + \lambda_3)x} dx + \lambda_1 \int_0^t (1 - e^{-\lambda_2 y}) e^{-(\lambda_1 + \lambda_3)y} dy \\
 &= \lambda_2 \int_0^t (e^{-(\lambda_2 + \lambda_3)x} - e^{-(\lambda_1 + \lambda_2 + \lambda_3)x}) dx + \lambda_1 \int_0^t (e^{-(\lambda_1 + \lambda_3)y} - e^{-(\lambda_1 + \lambda_2 + \lambda_3)y}) dy.
 \end{aligned}$$

Which after integration yields

$$\begin{aligned}
&= \left( \frac{\lambda_2}{\lambda_2 + \lambda_3} \right) (1 - e^{-(\lambda_2 + \lambda_3)t}) - \left( \frac{\lambda_2}{\lambda_1 + \lambda_2 + \lambda_3} \right) (1 - e^{-(\lambda_1 + \lambda_2 + \lambda_3)t}) \\
&\quad + \left( \frac{\lambda_1}{\lambda_1 + \lambda_3} \right) (1 - e^{-(\lambda_1 + \lambda_3)t}) - \left( \frac{\lambda_1}{\lambda_1 + \lambda_2 + \lambda_3} \right) (1 - e^{-(\lambda_1 + \lambda_2 + \lambda_3)t}). \quad (6)
\end{aligned}$$

The probability that the system fails due to component three failing is the sum of the chance of being at node four, five, or seven at time  $t$ ,

$$\begin{aligned}
P_4(t) + P_5(t) + P_7(t) &= P\{E_3 < E_1, E_3 < E_2 | T \leq t\} + P\{E_1 < E_3, E_3 < E_2 | T \leq t\} \\
&\quad + P\{E_2 < E_3, E_3 < E_1 | T \leq t\}.
\end{aligned}$$

The components of this expression are

$$\begin{aligned}
P_4(t) &= P\{E_3 < E_1, E_3 < E_2 | T \leq t\} \\
&= \int_0^t P\{E_3 < E_1, E_3 < E_2 | E_3 = x\} f_{E_3}(x) dx \\
&= \int_0^t P\{E_1 > x\} P\{E_2 > x\} f_{E_3}(x) dx \\
&= \int_0^t \lambda_3 e^{-(\lambda_1 + \lambda_2 + \lambda_3)x} dx \\
&= \left( \frac{\lambda_3}{\lambda_1 + \lambda_2 + \lambda_3} \right) (1 - e^{-(\lambda_1 + \lambda_2 + \lambda_3)t}),
\end{aligned}$$

$$\begin{aligned}
P_5(t) &= P\{E_1 < E_3, E_3 < E_2 | T \leq t\} \\
&= \int_0^t P\{E_1 < E_3, E_3 < E_2 | E_3 = x\} f_{E_3}(x) dx \\
&= \int_0^t P\{E_1 < x\} P\{E_2 > x\} f_{E_3}(x) dx \\
&= \int_0^t \lambda_3 e^{-(\lambda_2 + \lambda_3)x} (1 - e^{-\lambda_1 x}) dx \\
&= \left( \frac{\lambda_3}{\lambda_2 + \lambda_3} \right) (1 - e^{-(\lambda_2 + \lambda_3)t}) \\
&\quad - \left( \frac{\lambda_3}{\lambda_1 + \lambda_2 + \lambda_3} \right) (1 - e^{-(\lambda_1 + \lambda_2 + \lambda_3)t}), \text{ and}
\end{aligned}$$

$$\begin{aligned}
P_7(t) &= P\{E_2 < E_3, E_3 < E_1 | T \leq t\} \\
&= \int_0^t P\{E_2 < E_3, E_3 < E_1 | E_3 = x\} f_{E_3}(x) dx \\
&= \int_0^t P\{E_2 < x\} P\{E_1 > x\} f_{E_3}(x) dx \\
&= \int_0^t \lambda_3 e^{-(\lambda_1 + \lambda_3)x} (1 - e^{-\lambda_2 x}) dx \\
&= \left( \frac{\lambda_3}{\lambda_1 + \lambda_3} \right) (1 - e^{-(\lambda_1 + \lambda_3)t}) \\
&\quad - \left( \frac{\lambda_3}{\lambda_1 + \lambda_2 + \lambda_3} \right) (1 - e^{-(\lambda_1 + \lambda_2 + \lambda_3)t}).
\end{aligned}$$

Thus, their sum ( $P_4(t) + P_5(t) + P_7(t)$ ), the probability of component three causing system failure, is

$$\begin{aligned}
&= \left( \frac{\lambda_3}{\lambda_2 + \lambda_3} \right) (1 - e^{-(\lambda_2 + \lambda_3)t}) + \left( \frac{\lambda_3}{\lambda_1 + \lambda_3} \right) (1 - e^{-(\lambda_1 + \lambda_3)t}) \\
&\quad - \left( \frac{\lambda_3}{\lambda_1 + \lambda_2 + \lambda_3} \right) (1 - e^{-(\lambda_1 + \lambda_2 + \lambda_3)t}). \tag{7}
\end{aligned}$$

To find total system unreliability at time  $t$ , the analyst need only take the sum of the probabilities found for component three causing system failure and that for components one and two causing system failure. In other words the sum of Equations

(6) and (7), this sum is

$$\begin{aligned}
&= 1 - e^{-(\lambda_2+\lambda_3)t} + 1 - e^{-(\lambda_1+\lambda_3)t} - 1 + e^{-(\lambda_1+\lambda_2+\lambda_3)t} \\
&= 1 - e^{-(\lambda_1+\lambda_3)t} - e^{-(\lambda_2+\lambda_3)t} + e^{-(\lambda_1+\lambda_2+\lambda_3)t}.
\end{aligned} \tag{8}$$

Now in order to find the reliability of the system at any time  $t$ , the complement of the system's unreliability, Equation (8), can be taken or the probability of being at any of the transient nodes can be found. This probability is equivalent to summing the probabilities of being at nodes one, two, or three at time  $t$ . Summing these expressions gives the probability of system survival at time  $t$ ,  $S_T(t)$ . This expression is given as

$$\begin{aligned}
P_1(t) + P_2(t) + P_3(t) &= P\{E_1 > t\}P\{E_2 > t\}P\{E_3 > t\} \\
&\quad + P\{E_1 < t\}P\{E_2 > t\}P\{E_3 > t\} \\
&\quad + P\{E_1 > t\}P\{E_2 < t\}P\{E_3 > t\} \\
&= e^{-(\lambda_1+\lambda_2+\lambda_3)t} + (1 - e^{-\lambda_1 t})e^{-(\lambda_2+\lambda_3)t} + (1 - e^{-\lambda_2 t})e^{-(\lambda_1+\lambda_3)t} \\
&= e^{-(\lambda_1+\lambda_2+\lambda_3)t} + e^{-(\lambda_2+\lambda_3)t} - e^{-(\lambda_1+\lambda_2+\lambda_3)t} + e^{-(\lambda_1+\lambda_3)t} \\
&\quad - e^{-(\lambda_1+\lambda_2+\lambda_3)t} \\
&= e^{-(\lambda_1+\lambda_3)t} + e^{-(\lambda_2+\lambda_3)t} - e^{-(\lambda_1+\lambda_2+\lambda_3)t}.
\end{aligned} \tag{9}$$

To check our answer for the system's reliability the system's structure function can be used. Using this technique the system's reliability is

$$\begin{aligned}
&= e^{-\lambda_3 t} (1 - (1 - e^{-\lambda_1 t}) (1 - e^{-\lambda_2 t})) \\
&= e^{-\lambda_3 t} (e^{-\lambda_2 t} + e^{-\lambda_1 t} - e^{-(\lambda_1+\lambda_2)t}) \\
&= e^{-(\lambda_1+\lambda_3)t} + e^{-(\lambda_2+\lambda_3)t} - e^{-(\lambda_1+\lambda_2+\lambda_3)t}.
\end{aligned} \tag{10}$$

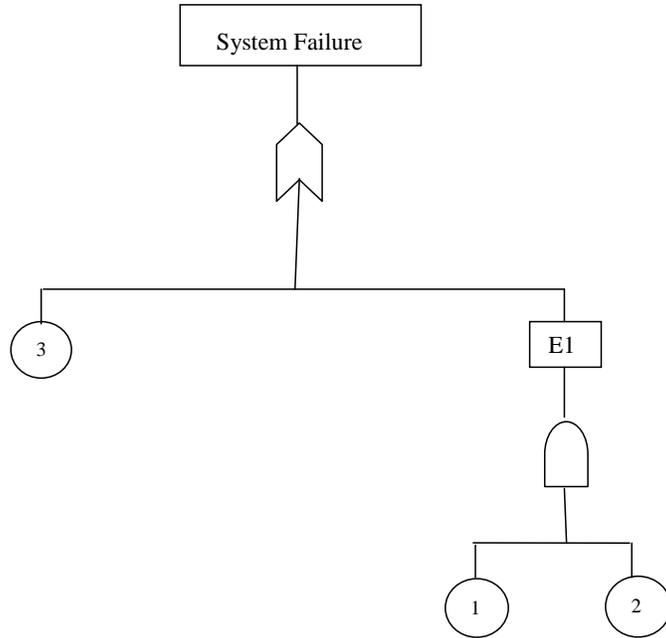

Figure 19: FT of System with Components in Series and Parallel

Clearly, this result (Equation (10)) is the same expression found in Equation (9) and in the complement of Equation (8). The standard technique is noticeably less complex than the one used above via EONs, however it does not produce the probabilities of system failure from each possible cause at time  $t$ . Thus, using EONs to calculate a system's reliability produces a more detailed analysis.

*5.2.1.1 Fault Tree and Minimal Cut Set Analysis.* A fault tree (FT) for the above three-component system is given in Figure 19, and is the minimal tree that can be drawn for the system. This means that all of the minimal cut sets are in series (or gate) with each of their elements in parallel (and gate). As can be seen from Figure 19, the minimal cut sets are components one and two, and component three.

As stated before in Section 3.2.3, the minimal cut sets for a given coherent system can be found via boolean algebra. More specifically, the minimal cut sets are found by taking the union of the intersection of the basic events for each terminating event stream. In other words, by taking the union of the terminating nodes, where

each terminating node is broken down into the intersection of its basic events. The example that follows demonstrates how this technique is used. In this example  $\cup$  represents the union of two events and  $\cap$  denotes the intersection. In addition,  $\oplus$  denotes the boolean plus operation and  $\otimes$  the boolean times operation. Using this notation the minimal cut sets are given as

$$\begin{aligned}
 \text{Node 4} \cup \text{Node 5} \cup \text{Node 6} \cup \text{Node 7} &= \text{Event 3} \cup (\text{Event 1} \cap \text{Event 3}) \\
 &\cup (\text{Event 1} \cap \text{Event 2}) \cup (\text{Event 2} \cap \text{Event 3}) \\
 &= 3 \oplus (1 \otimes 3) \oplus (1 \otimes 2) \oplus (2 \otimes 3) \\
 &= 3 \oplus (1 \otimes 2).
 \end{aligned}$$

This shows that, from the EON system representation, the minimal cut sets are in fact component three and components one and two, as was found previously.

*5.2.2 Reliability of a Complex System.* Now suppose an analysis of the reliability of the complex system with RBD shown in Figure 20 on the following page is desired. As can be seen from the EON for this system, Figure 21 on the next page, an EON grows larger and more complex as the number of possible path and cut vectors grows. As was shown in the previous examples, the probabilities can be found via conditioning and closed form solutions are available for systems with exponentially distributed life times. This example demonstrates how the number of nodes in the EON required for complex systems grows, since the enumeration of all possible event streams is required. As evidenced from Denhard in [12], this node explosion can be overcome by bucket analysis in which the EON structure and underlying stochastic model is truncated for rare event streams.

A table showing the events that have occurred by each node is shown in Table 9 on page 77. This is done to help eliminate confusion in determining which event streams have occurred at each node in Figure 21 on the next page.

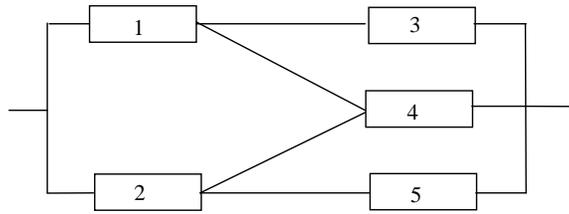

Figure 20: RBD of Complex System

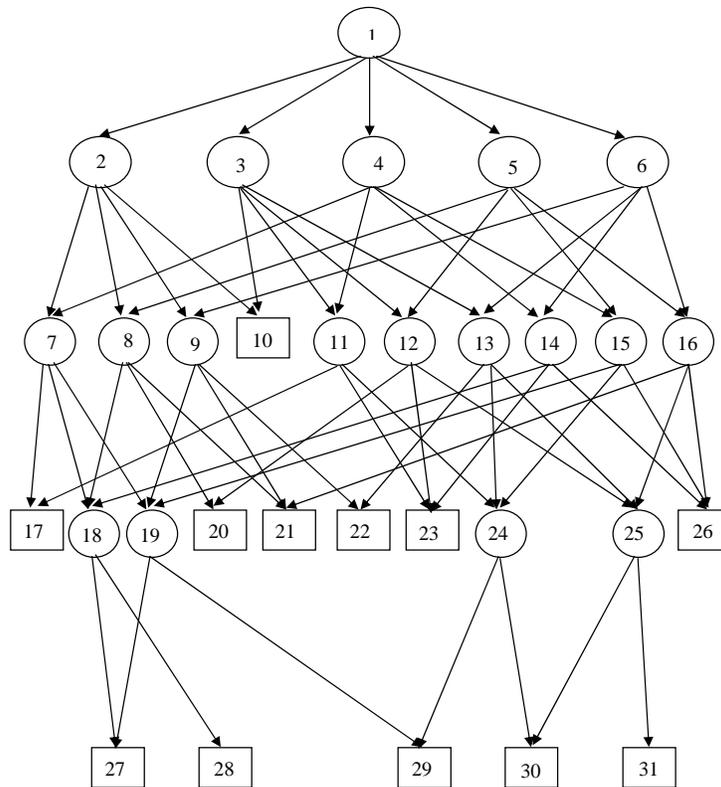

Figure 21: EON of Complex System

Table 9: Nodes with Associated Event Streams

<b>Node</b>	<b>Events Occurred</b>
1	Non-event
2	$E_1$
3	$E_2$
4	$E_3$
5	$E_4$
6	$E_5$
7	$E_1, E_3$
8	$E_1, E_4$
9	$E_1, E_5$
10	$E_1, E_2$
11	$E_2, E_3$
12	$E_2, E_4$
13	$E_2, E_5$
14	$E_3, E_4$
15	$E_3, E_5$
16	$E_4, E_5$
17	$E_1, E_2, E_3$
18	$E_1, E_3, E_4$
19	$E_1, E_3, E_5$
20	$E_1, E_2, E_4$
21	$E_1, E_4, E_5$
22	$E_1, E_2, E_5$
23	$E_2, E_3, E_4$
24	$E_2, E_3, E_5$
25	$E_2, E_4, E_5$
26	$E_3, E_4, E_5$
27	$E_1, E_3, E_4, E_5$
28	$E_1, E_2, E_3, E_4$
29	$E_1, E_2, E_3, E_5$
30	$E_2, E_3, E_4, E_5$
31	$E_1, E_2, E_4, E_5$

The nodal probabilities for this system can be calculated in a similar manner to the examples given previously. To demonstrate how this is accomplished a few of these probability calculations are now shown. An exhaustive demonstration of the nodal probabilities for all of the nodes in this system is given in Appendix C. For this system assume that component  $i$ 's lifetime is exponentially distributed with rate  $\lambda_i$  for  $i = 1, \dots, 5$ . Additionally assume that the components fail independently of each other. The nodal probabilities for all of the intermediate nodes is exactly the same as was done previously, so this example will focus on the absorbing nodes (system failure). The probability expressions for absorbing nodes on the same tier are similar, so one calculation for a generic terminating node per tier is sufficient.

The first terminating node in this system, is located on tier two. Node ten represents the event stream where both components one and two have failed and thus the system is in a failed state, its probability expression is given as

$$P_{10}(t) = P\{E_1 < E_2, E_2 < E_3, E_2 < E_4, E_2 < E_5 | T \leq t\} \\ + P\{E_2 < E_1, E_1 < E_3, E_1 < E_4, E_1 < E_5 | T \leq t\}.$$

Conditioning on  $E_2$  in the first integral expression and  $E_1$  in the second gives

$$= \int_0^t P\{E_1 < x\} P\{E_3 > x\} P\{E_4 > x\} P\{E_5 > x\} f_{E_2}(x) dx \\ + \int_0^t P\{E_2 < y\} P\{E_3 > y\} P\{E_4 > y\} P\{E_5 > y\} f_{E_1}(y) dy \\ = \lambda_2 \int_0^t (1 - e^{-\lambda_1 x}) e^{-(\sum_{i=2}^5 \lambda_i)x} dx \\ + \lambda_1 \int_0^t (1 - e^{-\lambda_2 y}) e^{-(\sum_{i=1; i \neq 2}^5 \lambda_i)y} dy \\ = \lambda_2 \int_0^t e^{-(\sum_{i=2}^5 \lambda_i)x} - e^{-(\sum_{i=1}^5 \lambda_i)x} dx \\ + \lambda_1 \int_0^t e^{-(\sum_{i=1; i \neq 2}^5 \lambda_i)y} - e^{-(\sum_{i=1}^5 \lambda_i)y} dy.$$

The resulting integration gives

$$\begin{aligned}
&= \frac{\lambda_2 \left(1 - e^{-(\sum_{i=2}^5 \lambda_i)t}\right)}{\sum_{i=2}^5 \lambda_i} + \frac{\lambda_2 \left(e^{-(\sum_{i=1}^5 \lambda_i)t} - 1\right)}{\sum_{i=1}^5 \lambda_i} \\
&+ \frac{\lambda_1 \left(1 - e^{-(\sum_{i=1; i \neq 2}^5 \lambda_i)t}\right)}{\sum_{i=1; i \neq 2}^5 \lambda_i} + \frac{\lambda_1 \left(e^{-(\sum_{i=1}^5 \lambda_i)t} - 1\right)}{\sum_{i=1}^5 \lambda_i}.
\end{aligned}$$

The next tier, tier three, consists of event streams where three different events have occurred. Each node has either two or three paths coming into it. Nodes with only two paths (17, 20 and 22) are missing the path from parent node 10, which is not feasible since node 10 represents an absorbing state.

The absorbing nodes in this tier (nodes 17, 20-23, and 26), represent specific sequences of component failures that eventually lead to system failure at this tier. To simplify matters a generic sequential failure sequence is analyzed. In general the probability of component  $a$  failing first followed by component  $b$ , followed by component  $c$  where component  $d$  and  $e$  have not yet failed, is given as

$$\begin{aligned}
&P \{E_a < E_b, E_b < E_c, E_c < E_d, E_c < E_e | T \leq t\} \\
&= \int_0^t \int_0^y P \{E_a < x\} P \{E_d > y\} P \{E_e > y\} f_{E_b}(x) dx f_{E_c}(y) dy \\
&= \lambda_b \lambda_c \int_0^t \int_0^y (1 - e^{-\lambda_a x}) e^{-(\lambda_c + \lambda_d + \lambda_e)y} e^{-\lambda_e x} dx dy \\
&= \lambda_b \lambda_c \int_0^t \int_0^y (e^{-\lambda_b x} - e^{-(\lambda_a + \lambda_b)x}) e^{-(\lambda_c + \lambda_d + \lambda_e)y} dx dy \\
&= \lambda_b \lambda_c \int_0^t \left( \frac{1}{\lambda_b} (1 - e^{-\lambda_b y}) + \frac{1}{\lambda_a + \lambda_b} (e^{-(\lambda_a + \lambda_b)y} - 1) \right) e^{-(\lambda_c + \lambda_d + \lambda_e)y} dy \\
&= \lambda_c \int_0^t (e^{-(\lambda_c + \lambda_d + \lambda_e)y} - e^{-(\lambda_b + \lambda_c + \lambda_d + \lambda_e)y}) dy \\
&+ \frac{\lambda_b \lambda_c}{\lambda_1 + \lambda_2} \int_0^t (e^{-(\lambda_a + \lambda_b + \lambda_c + \lambda_d + \lambda_e)y} - e^{-(\lambda_c + \lambda_d + \lambda_e)y}) dy.
\end{aligned}$$

Carrying out the integration

$$\begin{aligned}
&= \frac{\lambda_c}{\lambda_c + \lambda_d + \lambda_e} (1 - e^{-(\lambda_c + \lambda_d + \lambda_e)t}) + \frac{\lambda_c}{\lambda_b + \lambda_c + \lambda_d + \lambda_e} (e^{-(\lambda_b + \lambda_c + \lambda_d + \lambda_e)t} - 1) \\
&\quad + \frac{\lambda_b \lambda_c}{\lambda_a + \lambda_b} \left( \frac{1 - e^{-(\lambda_a + \lambda_b + \lambda_c + \lambda_d + \lambda_e)t}}{\lambda_a + \lambda_b + \lambda_c + \lambda_d + \lambda_e} + \frac{e^{-(\lambda_c + \lambda_d + \lambda_e)t} - 1}{\lambda_c + \lambda_d + \lambda_e} \right). \tag{11}
\end{aligned}$$

The expressions for the absorbing nodes can now be expressed by plugging the relevant failure sequences into Equation (11). As stated before nodes 17, 20 and 22 only have two different paths from parent nodes in tier two, yielding a total of four different possible event stream combinations that conclude at these nodes. The remaining absorbing nodes on tier three, nodes 21,23 and 26, have three different paths from their respective parent nodes, yielding a total of six possible event stream combinations leading to these nodes. This means that each possible failure sequence must be substituted into Equation (11) for each terminating node and these results summed to obtain total node probability. For example

$$\begin{aligned}
P_{17}(t) &= P \{E_1 < E_3, E_3 < E_2, E_2 < E_4, E_2 < E_5 | T \leq t\} \\
&\quad + P \{E_3 < E_1, E_1 < E_2, E_2 < E_4, E_2 < E_5 | T \leq t\} \\
&\quad + P \{E_2 < E_3, E_3 < E_1, E_1 < E_4, E_1 < E_5 | T \leq t\} \\
&\quad + P \{E_3 < E_2, E_2 < E_1, E_1 < E_4, E_1 < E_5 | T \leq t\}.
\end{aligned}$$

Which after substitution into Equation (11) gives

$$\begin{aligned}
&= \frac{\lambda_2}{\lambda_2 + \lambda_4 + \lambda_5} (1 - e^{-(\lambda_2 + \lambda_4 + \lambda_5)t}) + \frac{\lambda_2}{\lambda_2 + \lambda_3 + \lambda_4 + \lambda_5} (e^{-(\lambda_2 + \lambda_3 + \lambda_4 + \lambda_5)t} - 1) \\
&+ \frac{\lambda_2 \lambda_3}{\lambda_1 + \lambda_3} \left( \frac{1 - e^{-(\lambda_1 + \lambda_2 + \lambda_3 + \lambda_4 + \lambda_5)t}}{\lambda_1 + \lambda_2 + \lambda_3 + \lambda_4 + \lambda_5} + \frac{e^{-(\lambda_2 + \lambda_4 + \lambda_5)t} - 1}{\lambda_2 + \lambda_4 + \lambda_5} \right) \\
&+ \frac{\lambda_2}{\lambda_2 + \lambda_4 + \lambda_5} (1 - e^{-(\lambda_2 + \lambda_4 + \lambda_5)t}) + \frac{\lambda_2}{\lambda_1 + \lambda_2 + \lambda_4 + \lambda_5} (e^{-(\lambda_1 + \lambda_2 + \lambda_4 + \lambda_5)t} - 1) \\
&+ \frac{\lambda_1 \lambda_2}{\lambda_1 + \lambda_3} \left( \frac{1 - e^{-(\lambda_1 + \lambda_2 + \lambda_3 + \lambda_4 + \lambda_5)t}}{\lambda_1 + \lambda_2 + \lambda_3 + \lambda_4 + \lambda_5} + \frac{e^{-(\lambda_2 + \lambda_4 + \lambda_5)t} - 1}{\lambda_2 + \lambda_4 + \lambda_5} \right) \\
&+ \frac{\lambda_1}{\lambda_1 + \lambda_4 + \lambda_5} (1 - e^{-(\lambda_1 + \lambda_4 + \lambda_5)t}) + \frac{\lambda_1}{\lambda_1 + \lambda_3 + \lambda_4 + \lambda_5} (e^{-(\lambda_1 + \lambda_3 + \lambda_4 + \lambda_5)t} - 1) \\
&+ \frac{\lambda_1 \lambda_3}{\lambda_2 + \lambda_3} \left( \frac{1 - e^{-(\lambda_1 + \lambda_2 + \lambda_3 + \lambda_4 + \lambda_5)t}}{\lambda_1 + \lambda_2 + \lambda_3 + \lambda_4 + \lambda_5} + \frac{e^{-(\lambda_1 + \lambda_4 + \lambda_5)t} - 1}{\lambda_1 + \lambda_4 + \lambda_5} \right) \\
&+ \frac{\lambda_1}{\lambda_1 + \lambda_4 + \lambda_5} (1 - e^{-(\lambda_1 + \lambda_4 + \lambda_5)t}) + \frac{\lambda_1}{\lambda_1 + \lambda_2 + \lambda_4 + \lambda_5} (e^{-(\lambda_1 + \lambda_2 + \lambda_4 + \lambda_5)t} - 1) \\
&+ \frac{\lambda_1 \lambda_2}{\lambda_2 + \lambda_3} \left( \frac{1 - e^{-(\lambda_1 + \lambda_2 + \lambda_3 + \lambda_4 + \lambda_5)t}}{\lambda_1 + \lambda_2 + \lambda_3 + \lambda_4 + \lambda_5} + \frac{e^{-(\lambda_1 + \lambda_4 + \lambda_5)t} - 1}{\lambda_1 + \lambda_4 + \lambda_5} \right).
\end{aligned}$$

Finally, tier four, the last tier in this particular EON is comprised solely of terminating nodes. Each node represents the failure of four different components. The nodes with only one parent node in the previous tier, nodes 28 and 31, have a total of six possible component failure sequences leading to them, while the remaining nodes have a total of twelve different component failure sequences. Once again, as was done in tier three, a generic failure sequence is analyzed to simplify the calculation of the nodal probabilities for this tier. Consider the case when component  $a$  fails first, followed by  $b$ ,  $c$ , then  $d$ , leaving component  $e$  as the only one that has not failed. The

probability of this event sequence is given as

$$\begin{aligned}
& P\{E_a < E_b, E_b < E_c, E_c < E_d, E_d < E_e | T \leq t\} \\
&= \int_0^t \int_0^z \int_0^y P\{E_a < x\} P\{E_e > z\} f_{E_b}(x) dx f_{E_c}(y) dy f_{E_d}(z) dz \\
&= \lambda_b \lambda_c \lambda_d \int_0^t \int_0^z \int_0^y (1 - e^{-\lambda_a x}) e^{-(\lambda_d + \lambda_e)z} e^{-\lambda_b x} e^{-\lambda_c y} dx dy dz \\
&= \lambda_b \lambda_c \lambda_d \int_0^t \int_0^z \int_0^y (e^{-\lambda_b x} - e^{-(\lambda_a + \lambda_b)x}) e^{-\lambda_c y} e^{-(\lambda_d + \lambda_e)z} dx dy dz \\
&= \lambda_c \lambda_d \int_0^t \int_0^z \left(1 - e^{-\lambda_b y} + \frac{\lambda_b}{\lambda_a + \lambda_b} (e^{-(\lambda_a + \lambda_b)y} - 1)\right) e^{-\lambda_c y} e^{-(\lambda_d + \lambda_e)z} dy dz \\
&= \lambda_c \lambda_d \int_0^t \int_0^z \left(e^{-\lambda_c y} - e^{-(\lambda_b + \lambda_c)y} + \frac{\lambda_b}{\lambda_a + \lambda_b} (e^{-(\lambda_a + \lambda_b + \lambda_c)y} - e^{-\lambda_c y})\right) e^{-(\lambda_d + \lambda_e)z} dy dz \\
&= \lambda_d \int_0^t \left(1 - e^{-\lambda_c z} + \frac{\lambda_c}{\lambda_b + \lambda_c} (e^{-(\lambda_b + \lambda_c)z} - 1)\right. \\
&\quad \left.+ \frac{\lambda_b \lambda_c}{\lambda_a + \lambda_b} \left(\frac{1 - e^{-(\lambda_a + \lambda_b + \lambda_c)z}}{\lambda_a + \lambda_b + \lambda_c} + \frac{e^{-\lambda_c z} - 1}{\lambda_c}\right)\right) e^{-(\lambda_d + \lambda_e)z} dz.
\end{aligned}$$

Splitting up these expressions into a sum of separate integrals gives

$$\begin{aligned}
&= \lambda_d \int_0^t e^{-(\lambda_d + \lambda_e)z} dz - \lambda_d \int_0^t e^{-(\lambda_c + \lambda_d + \lambda_e)z} dz + \frac{\lambda_c \lambda_d}{\lambda_b + \lambda_c} \int_0^t e^{-(\lambda_b + \lambda_c + \lambda_d + \lambda_e)z} dz \\
&\quad - \frac{\lambda_c \lambda_d}{\lambda_b + \lambda_c} \int_0^t e^{-(\lambda_d + \lambda_e)z} dz + \frac{\lambda_b \lambda_c \lambda_d}{(\lambda_a + \lambda_b)(\lambda_a + \lambda_b + \lambda_c)} \int_0^t e^{-(\lambda_d + \lambda_e)z} dz \\
&\quad - \frac{\lambda_b \lambda_c \lambda_d}{(\lambda_a + \lambda_b)(\lambda_a + \lambda_b + \lambda_c)} \int_0^t e^{-(\lambda_a + \lambda_b + \lambda_c + \lambda_d + \lambda_e)z} dz + \frac{\lambda_b \lambda_d}{\lambda_a + \lambda_b} \int_0^t e^{-(\lambda_c + \lambda_d + \lambda_e)z} dz \\
&\quad - \frac{\lambda_b \lambda_d}{\lambda_a + \lambda_b} \int_0^t e^{-(\lambda_d + \lambda_e)z} dz \\
&= \left(\lambda_d - \frac{\lambda_c \lambda_d}{\lambda_b + \lambda_c} + \frac{\lambda_b \lambda_c \lambda_d}{(\lambda_a + \lambda_b)(\lambda_a + \lambda_b + \lambda_c)} - \frac{\lambda_b \lambda_d}{\lambda_a + \lambda_b}\right) \int_0^t e^{-(\lambda_d + \lambda_e)z} dz \\
&\quad + \left(\frac{\lambda_b \lambda_d}{\lambda_a + \lambda_b} - \lambda_d\right) \int_0^t e^{-(\lambda_c + \lambda_d + \lambda_e)z} dz + \frac{\lambda_c \lambda_d}{\lambda_b + \lambda_c} \int_0^t e^{-(\lambda_b + \lambda_c + \lambda_d + \lambda_e)z} dz \\
&\quad - \frac{\lambda_b \lambda_c \lambda_d}{(\lambda_a + \lambda_b)(\lambda_a + \lambda_b + \lambda_c)} \int_0^t e^{-(\lambda_a + \lambda_b + \lambda_c + \lambda_d + \lambda_e)z} dz.
\end{aligned}$$

Which finally yields the desired solution

$$\begin{aligned}
&= \left( \lambda_d - \frac{\lambda_c \lambda_d}{\lambda_b + \lambda_c} + \frac{\lambda_b \lambda_c \lambda_d}{(\lambda_a + \lambda_b)(\lambda_a + \lambda_b + \lambda_c)} - \frac{\lambda_b \lambda_d}{\lambda_a + \lambda_b} \right) \left( \frac{1 - e^{-(\lambda_d + \lambda_e)t}}{\lambda_d + \lambda_e} \right) \\
&+ \left( \frac{\lambda_b \lambda_d}{\lambda_a + \lambda_b} - \lambda_d \right) \left( \frac{1 - e^{-(\lambda_c + \lambda_d + \lambda_e)t}}{\lambda_c + \lambda_d + \lambda_e} \right) \\
&+ \left( \frac{\lambda_c \lambda_d}{\lambda_b + \lambda_c} \right) \left( \frac{1 - e^{-(\lambda_b + \lambda_c + \lambda_d + \lambda_e)t}}{\lambda_b + \lambda_c + \lambda_d + \lambda_e} \right) \\
&+ \left( \frac{\lambda_b \lambda_c \lambda_d}{(\lambda_a + \lambda_b)(\lambda_a + \lambda_b + \lambda_c)} \right) \left( \frac{e^{-(\lambda_a + \lambda_b + \lambda_c + \lambda_d + \lambda_e)t} - 1}{\lambda_a + \lambda_b + \lambda_c + \lambda_d + \lambda_e} \right). \tag{12}
\end{aligned}$$

Now as was done previously, the different failure sequences that pertain to a particular node are substituted into Equation (12) and then summed in order to obtain the probability of being at that node at time  $t$ .

To verify that the above expressions are in fact correct, the path vector technique can be used to find this system's reliability. To use this technique all of the path vectors for the system must be found. The path vectors can be found via the code given in Appendix B. This code requires the minimal cut sets, they are

$$\mathcal{S} = \{\{1, 2\}, \{3, 4, 5\}, \{1, 4, 5\}, \{2, 3, 4\}\}.$$

The minimal cut sets are then used to create the  $\mathbf{V}$  matrix,

$$\mathbf{V} = \begin{bmatrix} 1 & 1 & 0 & 0 & 0 \\ 0 & 0 & 1 & 1 & 1 \\ 1 & 0 & 0 & 1 & 1 \\ 0 & 1 & 1 & 1 & 0 \end{bmatrix}.$$

Based on the minimal cut sets, the code produces all of the path vectors and places them in a matrix  $\mathbf{P}$ .  $\mathbf{P}$  contains a row for every possible path vector for the given

system, it is given as

$$\mathbf{P} = \begin{bmatrix} 0 & 1 & 0 & 0 & 1 \\ 0 & 1 & 0 & 1 & 0 \\ 0 & 1 & 0 & 1 & 1 \\ 0 & 1 & 1 & 0 & 1 \\ 0 & 1 & 1 & 1 & 0 \\ 0 & 1 & 1 & 1 & 1 \\ 1 & 0 & 0 & 1 & 0 \\ 1 & 0 & 0 & 1 & 1 \\ 1 & 0 & 1 & 0 & 0 \\ 1 & 0 & 1 & 0 & 1 \\ 1 & 0 & 1 & 1 & 0 \\ 1 & 0 & 1 & 1 & 1 \\ 1 & 1 & 0 & 0 & 1 \\ 1 & 1 & 0 & 1 & 0 \\ 1 & 1 & 0 & 1 & 1 \\ 1 & 1 & 1 & 0 & 0 \\ 1 & 1 & 1 & 0 & 1 \\ 1 & 1 & 1 & 1 & 0 \\ 1 & 1 & 1 & 1 & 1 \end{bmatrix} .$$

The reliability of this system is the sum of the probabilities for each path vector (rows of  $\mathbf{P}$ ). There are 19 total path vectors corresponding to the 19 rows of  $\mathbf{P}$ . As an example the probability of the path vector corresponding to the first row of  $\mathbf{P}$  is

$$= P \{ E_1 < t, E_3 < t, E_4 < t, E_2 > t, E_5 > t \} ,$$

Table 10: Limiting Probabilities for Absorbing Nodes in Complex EON

<b>Node</b>	<b>Limiting Probability</b>
10	0.0197802198
17	0.0120379620
20	0.0186036186
21	0.0894660895
22	0.0274420024
23	0.0903263403
26	0.3191558442
27	0.0693001443
28	0.0119047619
29	0.0455017205
30	0.2480935731
31	0.0483877234
<b>Sum</b>	<b>1.0000000000</b>

which is precisely the expression for  $P_{18}(t)$ . Starting at the top and finding the probabilities associated with each row and then summing these expressions:

$$\begin{aligned}
 &= P_{18}(t) + P_{19}(t) + P_7(t) + P_8(t) + P_9(t) + P_2(t) + P_{24}(t) + P_{11}(t) + P_{25}(t) + P_{12}(t) \\
 &\quad + P_3(t) + P_{13}(t) + P_{14}(t) + P_{15}(t) + P_4(t) + P_{16}(t) + P_5(t) + P_6(t) + P_1(t).
 \end{aligned}$$

This is precisely the sum of all of the intermediate nodes for this system's EON. Thus, it can be certain that the above expressions are correct for the intermediate nodes.

As another check, one can analyze the limiting probabilities of the terminating nodes. More specifically, one can look at the sum of the limit as  $t$  goes to infinity of the terminating nodes. In the long-term analysis, the terminating nodes are collectively exhaustive, and this sum should result in one. Rather than showing all of the lengthy algebra for the general case where component  $i$ 's life is exponentially distributed with rate  $\lambda_i$ , assume that component  $i$ 's lifetime is exponentially distributed with rate  $i$ ,  $i = 1, \dots, 5$ . Doing this gives the limiting nodal probabilities shown in Table 10. Thus, it is certain that the nodal probability expressions pertaining to this example are correct.

### 5.3 Reliability of Systems with Repairable Components

The focus is now switched to systems made up of repairable components. In order to compute availability measures for this type of system, the number of component failures and repairs that are allowed must be limited, which means that the availability measures calculated are estimates for the true system availability. Additionally, assume that the components do not fail or age (wear) when the system is in a failed state and that when repaired the components are *good as new*. Last, failure and repair times are assumed to be independent of one another.

Once again let  $E_{ij}$  denote the time until the  $j^{\text{th}}$  failure for component  $i$  and  $R_{ij}$  denote the  $j^{\text{th}}$  repair time for component  $i$ , where  $i = 1, \dots, n$ ,  $j = 1, \dots, m$ .  $F_{E_{ij}}$ ,  $S_{E_{ij}}$ , and  $f_{E_{ij}}$  respectively denote the cdf, the survivor function, and the pdf that describe the  $j^{\text{th}}$  lifetime for component  $i$  ( $F_{R_{ij}}$ ,  $S_{R_{ij}}$ , and  $f_{R_{ij}}$  for the repair events).

*5.3.1 Instantaneous Availability of a 2 Component Series System.* As an illustration, assume the system under study is made up of two repairable components in series. Only one component repair is allowed to take place before the next component failure places the system in a permanent failed state. Assume that both the component life and repairs time are exponentially distributed with rates  $\lambda_i$  and  $\mu_i$ ,  $i = 1, 2$ , respectively. The availability graph for this system is shown in Figure 22 on the next page. This figure shows how one component failing will cause the system to fail, but will be back in operational status as soon as that component is repaired. The dashed arrows represent repair events, where the non-failed components are not aging. The computations used to find all of the nodal probabilities are shown in Appendix D.

The probability that this system is available at any time  $t$  is equivalent to the probability of being at node one, four, five, or ten at any given time  $t$ . In addition to instantaneous availability, availability graphs allow the system to be decomposed and thus provide the means necessary to calculate other availability measures. As was the case with EONs and non-repairable systems, availability graphs make the calculation

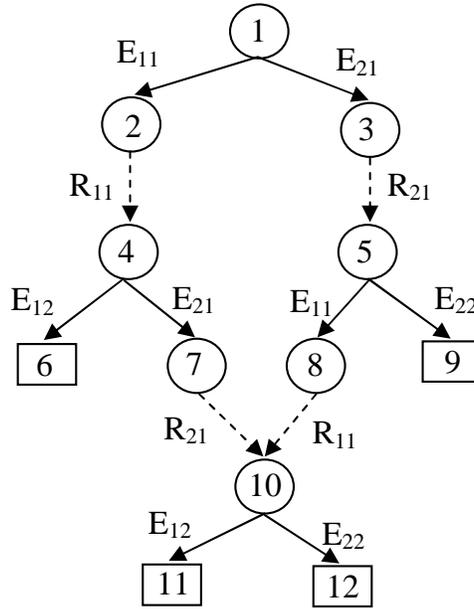

Figure 22: Availability Graph for 2 Repairable Components in Series (One Repair)

of the probability of the system being unavailable due to any specific cause, at any time  $t$ , relatively easy to determine.

To see these features more clearly assume that the system of concern is identical to the one described above with the following rates;

$$\begin{aligned} \lambda_1 &= 5, & \mu_1 &= 4, \\ \lambda_2 &= 6, & \mu_2 &= 3. \end{aligned}$$

The nodal probabilities for this availability graph are shown in Tables 11 on the following page and 12 on page 89. Additionally, the nodal probabilities are plotted over time in Figure 23 on the following page. From the figure and tables note that all of the terminating node probabilities approach a finite value as time goes on to infinity. This is expected since the terminating nodes represent absorbing states in the probabilistic model. Similarly, the intermediate nodal probabilities, since they represent transient states in the model, go to zero as  $t$  goes to infinity. The probability of being at node one is initially equal to one, since the system starts in an operational

Table 11: Nodal Probabilities - 2 Component Series Availability Graph

Time(t)	$P_1(t)$	$P_2(t)$	$P_3(t)$	$P_4(t)$	$P_5(t)$	$P_6(t)$	$P_7(t)$
0	1.000000	0.000000	0.000000	0.000000	0.000000	0.000000	0.000000
0.25	0.063928	0.217108	0.306329	0.078399	0.078914	0.059082	0.055698
0.5	0.004087	0.093749	0.164283	0.047733	0.057008	0.141457	0.093660
0.75	0.000261	0.035376	0.078853	0.019655	0.029129	0.181544	0.076266
1	0.000017	0.013071	0.037328	0.007421	0.013960	0.197294	0.048542
1.25	0.000001	0.004812	0.017638	0.002746	0.006611	0.203176	0.027598
1.5	0.000000	0.001770	0.008332	0.001011	0.003124	0.205347	0.014759
1.75	0.000000	0.000651	0.003936	0.000372	0.001476	0.206146	0.007606
2	0.000000	0.000240	0.001859	0.000137	0.000697	0.206440	0.003826
2.25	0.000000	0.000088	0.000878	0.000050	0.000329	0.206549	0.001893
2.5	0.000000	0.000032	0.000415	0.000019	0.000156	0.206588	0.000926
2.75	0.000000	0.000012	0.000196	0.000007	0.000073	0.206603	0.000449
3	0.000000	0.000004	0.000093	0.000003	0.000035	0.206608	0.000216
3.25	0.000000	0.000002	0.000044	0.000001	0.000016	0.206610	0.000104
3.5	0.000000	0.000001	0.000021	0.000000	0.000008	0.206611	0.000050
3.75	0.000000	0.000000	0.000010	0.000000	0.000004	0.206611	0.000024
4	0.000000	0.000000	0.000005	0.000000	0.000002	0.206612	0.000011
4.25	0.000000	0.000000	0.000002	0.000000	0.000001	0.206612	0.000005
4.5	0.000000	0.000000	0.000001	0.000000	0.000000	0.206612	0.000003
4.75	0.000000	0.000000	0.000000	0.000000	0.000000	0.206612	0.000001
5	0.000000	0.000000	0.000000	0.000000	0.000000	0.206612	0.000001

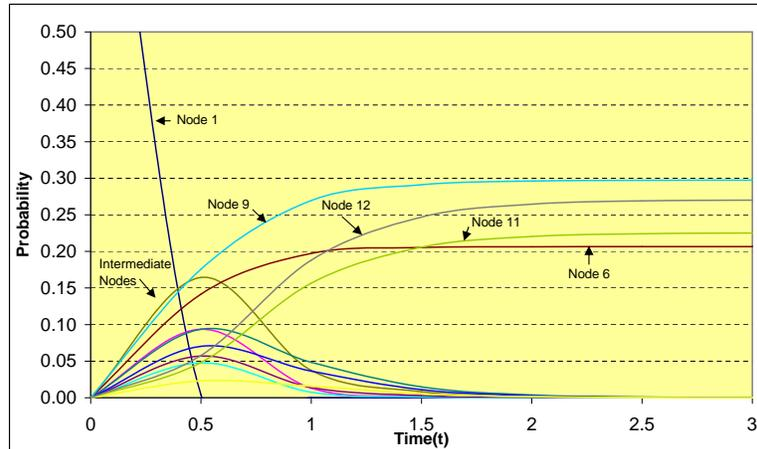

Figure 23: Nodal Probabilities for 2 Component Series Availability Graph

Table 12: Nodal Probabilities - 2 Component Series Availability Graph

<b>Time(t)</b>	<b>P<sub>8</sub>(t)</b>	<b>P<sub>9</sub>(t)</b>	<b>P<sub>10</sub>(t)</b>	<b>P<sub>11</sub>(t)</b>	<b>P<sub>12</sub>(t)</b>	<b>Sum</b>
<b>0</b>	0.000000	0.000000	0.000000	0.000000	0.000000	1.000000
<b>0.25</b>	0.041774	0.068368	0.017060	0.006064	0.007276	1.000000
<b>0.50</b>	0.070245	0.175601	0.046128	0.048204	0.057845	1.000000
<b>0.75</b>	0.057199	0.238543	0.045509	0.108029	0.129635	1.000000
<b>1</b>	0.036406	0.269540	0.031743	0.156672	0.188007	1.000000
<b>1.25</b>	0.020699	0.284294	0.018944	0.187946	0.225536	1.000000
<b>1.5</b>	0.011069	0.291272	0.010420	0.205861	0.247033	1.000000
<b>1.75</b>	0.005704	0.294569	0.005465	0.215488	0.258586	1.000000
<b>2</b>	0.002870	0.296126	0.002782	0.220465	0.264558	1.000000
<b>2.25</b>	0.001420	0.296862	0.001387	0.222974	0.267569	1.000000
<b>2.5</b>	0.000694	0.297210	0.000682	0.224217	0.269061	1.000000
<b>2.75</b>	0.000337	0.297374	0.000332	0.224826	0.269791	1.000000
<b>3</b>	0.000162	0.297451	0.000161	0.225121	0.270146	1.000000
<b>3.25</b>	0.000078	0.297488	0.000077	0.225264	0.270316	1.000000
<b>3.5</b>	0.000037	0.297505	0.000037	0.225332	0.270399	1.000000
<b>3.75</b>	0.000018	0.297513	0.000018	0.225365	0.270438	1.000000
<b>4</b>	0.000008	0.297517	0.000008	0.225380	0.270456	1.000000
<b>4.25</b>	0.000004	0.297519	0.000004	0.225388	0.270465	1.000000
<b>4.5</b>	0.000002	0.297520	0.000002	0.225391	0.270470	1.000000
<b>4.75</b>	0.000001	0.297520	0.000001	0.225393	0.270472	1.000000
<b>5</b>	0.000000	0.297520	0.000000	0.225394	0.270472	1.000000

Table 13: Availability Measures - 2 Component Series Availability Graph

<b>Time(t)</b>	<b>A(t)</b>	<b>Repair 1</b>	<b>Repair 2</b>	<b>Repair</b>	<b>U<sub>1</sub>(t)</b>	<b>U<sub>2</sub>(t)</b>
<b>0</b>	1.000000	0.000000	0.000000	0.000000	0.000000	0.000000
<b>0.25</b>	0.238301	0.258882	0.362027	0.620909	0.324027	0.437672
<b>0.5</b>	0.154956	0.163994	0.257943	0.421937	0.353656	0.491389
<b>0.75</b>	0.094554	0.092575	0.155119	0.247694	0.382148	0.523298
<b>1</b>	0.053141	0.049477	0.085869	0.135346	0.403443	0.543416
<b>1.25</b>	0.028302	0.025511	0.045236	0.070746	0.416633	0.555065
<b>1.5</b>	0.014556	0.012840	0.023091	0.035931	0.424048	0.561396
<b>1.75</b>	0.007313	0.006356	0.011542	0.017897	0.427990	0.564696
<b>2</b>	0.003616	0.003109	0.005685	0.008794	0.430015	0.566370
<b>2.25</b>	0.001767	0.001508	0.002771	0.004279	0.431031	0.567202
<b>2.5</b>	0.000857	0.000727	0.001341	0.002067	0.431532	0.567611
<b>2.75</b>	0.000413	0.000349	0.000645	0.000994	0.431778	0.567810
<b>3</b>	0.000198	0.000167	0.000309	0.000476	0.431896	0.567906
<b>3.25</b>	0.000095	0.000079	0.000147	0.000227	0.431954	0.567952
<b>3.5</b>	0.000045	0.000038	0.000070	0.000108	0.431981	0.567974
<b>3.75</b>	0.000021	0.000018	0.000033	0.000051	0.431994	0.567984
<b>4</b>	0.000010	0.000009	0.000016	0.000024	0.432000	0.567989
<b>4.25</b>	0.000005	0.000004	0.000008	0.000012	0.432003	0.567992
<b>4.5</b>	0.000002	0.000002	0.000004	0.000005	0.432005	0.567993
<b>4.75</b>	0.000001	0.000001	0.000002	0.000003	0.432005	0.567994
<b>5</b>	0.000001	0.000000	0.000001	0.000001	0.432006	0.567994

state with both of its components operating. As stated previously, the system's instantaneous availability for any time  $t$  is equal to  $P_1(t) + P_4(t) + P_5(t) + P_{10}(t)$ . Instantaneous availability,  $A(t)$ , is shown in Table 13 for different values of  $t$ .

In addition to instantaneous availability, the availability graph can be dissected and many other important measures can be found using this decomposition. For example, the probability that the system is unavailable because component one is awaiting repair is given as the sum of node two and eight's nodal probabilities. Similarly, the probability that the system is unavailable as a result of component two awaiting repair, is the probability of being at nodes three or seven at time  $t$ . These quantities are shown in Table 13, under the *Repair 1* and *Repair 2* columns. The probability that the system is unavailable because it is awaiting repair, at any time  $t$ , is the sum of the associated probabilities for each component. This quantity is shown under the *Repair* column in Table 13.

Last, one can analyze the probability that the system is unavailable due to different causes of failure. The probability that the system is unavailable due to component one for any time  $t$ , denoted  $U_1(t)$ , is

$$U_1(t) = P_2(t) + P_6(t) + P_8(t) + P_{11}(t).$$

The probability that the system is unavailable due to component two for any time  $t$  is computed in a similar fashion,

$$U_2(t) = P_3(t) + P_7(t) + P_9(t) + P_{12}(t).$$

These measures are also shown in Table 13, for different values of  $t$ . Note that as  $t$  grows indefinitely the probability that the system is unavailable is equal to one. Thus the sum of  $U_1(t)$  and  $U_2(t)$ , since these are the only possible causes of system unavailability, as  $t \rightarrow \infty$  is also equal to one. Finally, the analyst can be certain that the above nodal probabilities are correct, because their sum is equal to one for all time  $t$  (Table 12).

#### **5.4 Illustration Summary**

This chapter began by showing how to implement the techniques introduced in Chapter 3 for a specific three component non-repairable system. The system's reliability, and the contributinal probabilities for each component causing the system to fail were derived. Additionally, a fault tree for the system was depicted and used to find the minimal cut sets. This was done to show how these techniques can be used in finding the minimal cut sets from an EON. This section concluded with a RBD for a complex system. The EON for this system was depicted and the conditional nodal probabilities were presented.

The second section of this chapter provided an example of a system with repairable components. The system was limited by the number of repairs that are

allowed to occur, prior to the system remaining in a failed state. The nodal probabilities for this system are derived in Appendix D. This example demonstrated how an availability graph can be used to analyze a repairable system's instantaneous availability. Additionally, it was shown how the availability graph and its associated nodal probabilities allow for the computation of other valuable availability measures: the probability of a system being unavailable due to specific causes; and the probability of the system being unavailable because it is awaiting repair. This example is fairly simplistic in nature, when analyzing more complex repairable systems or when the aforementioned constraints are relaxed, calculating an availability graph's associated nodal probabilities explicitly, becomes more difficult.

## VI. Conclusion

### 6.1 Overview

This chapter presents the conclusions that the author has drawn from conducting this research. First, deductions are made from the topic's relevant background and literature. These deductions lead to the methods introduced in Chapters 3 and 4. Next, the methodology on reliability theory is analyzed to determine what conclusions can be drawn from this analysis. The research in this area is once again divided into two sections; one on the methodology for non-repairable system, and the other on the methodology used in the analysis of repairable systems. Following this, an outline for future research relevant to this thesis is given, with the hope that this work will be continued. Last, some final overarching recommendations are made.

### 6.2 Background and Literature Conclusions

A thorough analysis of reliability theory shows how vast and diverse the field really is. Despite this, some of the most basic reliability techniques are limited in many different ways. To start, there are many different graphical models that are used to capture and analyze the reliability of a given non-repairable system. None of these models possesses the diversity necessary to compute multiple different reliability measures.

Reliability block diagrams (RBDs) portray a system's functional relationship and the interaction between the system's components [23]. RBDs and the techniques associated with them, i.e. structure functions, can be used to capture overall system reliability. They are not so good, however, at capturing other reliability measures, like the probability of a component or group of components causing the system to fail. RBDs can also be used to find the minimal cut sets for a given system, but typically fault trees (FTs) are used in this area.

In addition to finding minimal cut sets, FTs are also used in determining the causes of system failure. They cannot however be used as a stand alone representation of a system, because they do not depict the interactions between components.

Additionally, if the system has many minimal cut sets, then calculating the system's reliability via FTs can be both costly and time consuming [38]. Event trees (ETs) are limited in the same areas that FTs are. For these reasons a graphical model that shows component dependencies and interactions and allows for the calculation of all of these reliability measures is desired.

Typically, component lifetimes are assumed to be exponentially distributed. This is done so that exact analytical solutions for system reliability can be found. However, this assumption reduces the models explicitness for a given system [24]. Often, lifetimes are better represented by different (non-exponential) distributions. However, when general distributions are used the system's reliability become much harder to calculate and it is for this reason that simulation is used [23]. Simulation can produce fairly accurate results but with more complex systems is very costly and time consuming.

Yet another approach involves the use of continuous time markov chains (CTMCs). CTMCs are often used in reliability analysis, but are limited in their modeling capabilities. When used to determine the probability of a component or group of components causing system failure at a specific time  $t$ , difficult calculations must be made due to the complexity of the expression needed to find the transition probability matrix. Additionally, the number of states required to model a coherent system with a CTMC grows increasingly large as the number of components and the complexity of the system increases. For these reasons a more robust reliability analysis should be examined.

When systems with repairable components are analyzed, the number of limitations increases. Due to the complex nature of availability measures, limiting availability is typically the only measure that is analyzed [23]. The instantaneous availability however is the most robust, because all of the other three measures can be derived from it. The correct availability measure is determined by analyzing how the system under scrutiny is to be used [24]. The complexity in calculating instantaneous, aver-

age, and limiting average availability drive analysts to use simulation. However, as stated previously, simulation is not always cost effective or accurate.

As is the case with non-repairable components, typically component life and repair times are assumed to be exponentially distributed. If the exponential assumption is lifted then the system's availability, more specifically the system's instantaneous availability, becomes extremely difficult to calculate and non-analytical techniques are used. Finding a system's, with non-exponential failure and repair times, instantaneous availability is so difficult that little to no work has been done in this area [24].

For these reasons an all-inclusive graphical reliability model that is diverse enough to handle all of the above requirements is desired. This longing leads to the application of a new graphical and probabilistic model.

### ***6.3 Methodology Conclusions***

As was shown in Chapters 3 and 4, event occurrence networks (EONs) can be used to model any coherent structure, whether the components are repairable or not. The EON structure allows for the computation of many different reliability measures. The techniques and assumptions used to do so are slightly different depending on whether the system consists of repairable components or non-repairable components.

If the system of concern is made up of non-repairable components then the EON structure can efficiently be utilized in reliability analysis. It was proved in Chapter 3 that every RBD can be transformed into its corresponding EON. This EON can then be used to calculate probabilities associated with the system's reliability. More specifically, this probabilistic model grants the analyst the tools necessary to calculate the probability of a component or group of components causing system failure, along with system reliability at a specific time  $t$ . This dissection breaks even the most complex system into simple component and groups of component probabilities. These probabilities are not intuitive and their calculations are not straight-forward using existing models and techniques. However, these calculations are essential in reliability

analysis, because they provide the analyst a way in which to cost-effectively improve system reliability.

In addition to these measures, EONs provide the analyst with the system's minimal cut sets. Previous techniques depend on yet another graphical model, FTs, to find these extremely valuable sets. The EON structure allows for the calculation of system reliability, contributonal probabilities, and minimal cut sets in one intuitive graphical model.

Lastly, EONs can be used alongside with numerical approximation techniques when component failures are generally distributed (non-exponential). When modeling systems with generally distributed component lifetimes, simulation is often used, which is timely and expensive. As was shown in [12], piecewise polynomial approximation can be used coupled with EONs to produce results that are very accurate.

The application of EONs to reliability theory leads to the main contribution of this thesis: the introduction of a graphical model that is robust enough to handle many different reliability measures, that at the same time presents an intuitive graphical depiction of the system at hand. The only downside to using the aforementioned technique (EONs) to calculate system reliability measures is that, just like other techniques, more complicated systems require extensive and involved calculations. Additionally, the state space for more complex systems grows unmanageably large, making the development of a software package that handles this a necessity.

Changing the focus to systems with repairable components makes this analysis much more complicated. The probabilistic model now represents the superposition of several non-terminating, interdependent counting processes that must be approximated with finite, terminating counting processes. The structure that reflects these changes for this type of system, termed an *availability graph*, is based on that of an EON. Theoretically, in an availability graph, components can fail and be repaired an infinite number of times. Thus, for this reason, each component's lifetime can be modeled as an alternating renewal process. To handle this complication, the analyst

must assume that only a finite number of repairs are allowed to take place. Additionally, events between groups no longer occur independently of one another. For these reasons, EONs alone, cannot be used to calculate a given system's availability.

Despite the complications, if it is assumed that once a component that has failed and caused system failure is repaired and the entire system is now *good as new*, then EONs paired with structure functions can be used to calculate the system's availability. In doing so the classical EON model is used, coupled with piecewise polynomial approximation, to estimate each component's availability. Each component's availability is then used in the system's structure function to find the system's overall availability.

Through the above described technique it was shown that very accurate results for system availability can be produced using piecewise polynomial approximation and EONs. The results were compared to those produced via simulation and it was shown that EONs and these techniques produce more accurate results than simulation, especially when the system is only analyzed for a short period of time. Furthermore, using EONs to calculate a system's availability is computationally less expensive than that of simulation. Thus, so long as this assumption does not detract from the model's explicitness of the given system, these techniques can be used.

Removing the assumption that the entire system is restored to a *good as new* condition when the failed component is repaired, makes availability calculations extremely difficult. The time element is no longer consistent amongst components. For example, if component one fails prior to component two and causes system failure, then following component one's repair, the clock starts over for component one but picks up where it left off for component two. This fact makes the calculation of even the simplest system's availability nearly untractable and explains why little work has been done in this area. The examples shown in Chapters 4 and 5 model very simple systems.

In addition to a system's instantaneous availability, these examples show how availability graphs may be used to calculate multiple different availability measures. As is the case for non-repairable systems, the availability graph allows for a useful decomposition of the given system. This decomposition provides the tools necessary to calculate the probability the system is unavailable due to specific causes, yielding a much more thorough analysis of the system's availability. However, even after strict limitations are placed on the systems (one repair), the instantaneous availability is still not easy to compute. This also explains why a system of this type's transient behavior is rarely analyzed.

From the analysis done for systems of this type, it is apparent that more work needs to be done in order to develop a more straight-forward technique that can handle any coherent structure. The research done thus far has not shed light on a method or pattern common to coherent systems that can be used to simplify these calculations. This leads to other areas where more research is necessary.

#### ***6.4 Future Research Opportunities***

First, the work done with EONs and non-repairable systems can still be expanded. There are many other areas of reliability that could be analyzed using the EON structure. Some of these include component importance, phase-type distributions, competing risks, accelerated life testing, and censoring. The hope is that the EON structure will make the analysis in some of these areas simpler than existing techniques. Next, the code written is based on the availability of minimal cut sets. As it stand now, this code only produces all of the path and cut vectors for a given system, based on the minimal cut sets. It is well known that if the minimal cut sets can be found, then the exact system's reliability can be found [23]. This code should be adapted so that the minimal cut sets are not required and thus significantly advance the use of EONs in this field. Once done an analysis should be undergone that determines whether the EON structure can find the minimal cut sets more efficiently

than existing methods. Computer code also needs to be written that can depict any coherent system as an EON graphically.

The next area of future research concerns systems with repairable components. The examples shown here are very limited and in future studies need to be expanded in many regards. First, the examples given were only limited to one repair event. Expanding this to a larger number of repairs and eventually letting this number approach infinity will result in a system's true instantaneous availability. The techniques for this type of system need also be expanded for other coherent systems. Perhaps first a simple parallel structure and then the results generalized for any coherent structure. Doing so will allow for the calculation of any system's instantaneous availability and will break new ground in an area that has had very little to no attention. Eventually computer code is necessary to deal with the complexity of these systems, and their sometimes involved calculations.

### ***6.5 Final Recommendations***

This research leads to many different overarching recommendations. To start, the main push is for EONs and their techniques to be adopted in the study of reliability. This will address and alleviate many of the problems with reliability analysis and current techniques.

EONs should be included in the realm of reliability theory for many reasons. First and foremost, EONs and their techniques allow for a more thorough system reliability analysis than any of the aforementioned graphical models that are currently being used. EONs, more specifically, allow for the calculation of many reliability measures that currently require multiple different graphical depictions. EONs can also be efficiently used, coupled with piecewise polynomial approximation, when component life and repair times are not exponentially distributed. Additionally, the EON structure represents an intuitive depiction of the system being studied. For these reasons EONs offer, what this author has termed an all-inclusive graphical model, to the field of reliability.

When the systems of concern are made up of repairable components then a model derived from EONs can be used to better understand an area where little research has been done. These techniques and what is termed an *availability graph*, opens the door to a relatively new area of study; namely the analysis of a system's instantaneous availability.

This work is beneficial to all of the areas that utilize reliability theory. As was stated in Chapter 1, these areas are as vast and diverse as can be imagined, and the contributions of this research are just as wide-spread.

*Appendix A. Instantaneous Availability via CTMC's and Laplace Transforms*

Using first principles, the differential-difference equations, describing the stochastic behavior of the system can be obtained, where  $P_k(t)$  is the probability of being in state  $k$  at time  $t$  [14].

$$\frac{dP_0(t)}{dt} = -\lambda P_0(t) + \mu P_1(t) \quad (13)$$

$$\frac{dP_1(t)}{dt} = \lambda P_0(t) - \mu P_1(t). \quad (14)$$

Now take the Laplace transform of these two equations with the initial conditions  $P_0(0) = 1$ , and  $P_1(0) = 0$ , since it is assumed that the system is functioning at time 0. For notational purposes assume  $f^*(s) = \mathcal{L}\{f(t)\}$ , in other words  $f^*(s)$  is the Laplace transform of  $f(t)$ . Thus for equation (13),

$$\begin{aligned} \mathcal{L}\left\{\frac{dP_0(t)}{dt}\right\} &= \mathcal{L}\{-\lambda P_0(t) + \mu P_1(t)\} \\ sP_0^*(s) - P_0(0) &= -\lambda P_0^*(s) + \mu P_1^*(s) \\ \Rightarrow P_1^*(s) &= \left(\frac{s + \lambda}{\mu}\right) P_0^*(s) - \frac{1}{\mu}. \end{aligned}$$

Similarly with equation (14),

$$\begin{aligned} \mathcal{L}\left\{\frac{dP_1(t)}{dt}\right\} &= \mathcal{L}\{\lambda P_0(t) - \mu P_1(t)\} \\ sP_1^*(s) - P_1(0) &= \lambda P_0^*(s) - \mu P_1^*(s) \\ \Rightarrow P_0^*(s) &= \left(\frac{s + \mu}{\lambda}\right) P_1^*(s). \end{aligned}$$

Solving this system of equations for  $P_0^*(s)$  yields

$$\begin{aligned}
 P_0^*(s) &= \left(\frac{s+\mu}{\lambda}\right) \left[ \left(\frac{s+\lambda}{\mu}\right) P_0^*(s) - \frac{1}{\mu} \right] \\
 \Rightarrow P_0^*(s) \left[ 1 - \left(\frac{s+\mu}{\lambda}\right) \left(\frac{s+\lambda}{\mu}\right) \right] &= -\frac{1}{\mu} \\
 \Rightarrow P_0^*(s) &= -\frac{\frac{1}{\mu}}{1 - \left(\frac{s+\mu}{\lambda}\right) \left(\frac{s+\lambda}{\mu}\right)} \\
 \Rightarrow P_0^*(s) &= \frac{1}{\left(\frac{s+\mu}{\lambda}\right) (s+\lambda) - \mu}.
 \end{aligned}$$

Now the quantity of interest, the instantaneous availability  $A(t)$ , is the inverse transform of  $P_0^*(s)$ , or

$$A(t) = \mathcal{L}^{-1}\{P_0^*(s)\} = \left(\frac{\lambda}{\lambda+\mu}\right) e^{-(\lambda+\mu)t} + \left(\frac{\mu}{\lambda+\mu}\right).$$

*Appendix B. Matlab<sup>®</sup> Code for Obtaining all of the Path and Cut  
Vectors for a Coherent System*

```

%*****
%Greg Steeger *
%Thesis EON Code *
%In this code an mxn binary matrix V is inputted, consisting of the*
%m minimal cut sets, for the given system. A "1" in row i column *
%"j" means that the jth component is an element of the ith minimal *
%cut set. The code then outputs all of the path and cut vectors. *
%*****
function [X,P,C]=EON(A)
XX=[];
X=[]; % X is a matrix of all possible state vectors with dimension n
C=[]; % C is a matrix of all of the cut vectors
P=[]; % P is a matrix of all of the path vectors

[m,n]=size(V); % system has m cut vectors of dimension n (n components)
y=zeros(m,n);

for i=0:(2^n)-1
    XX=[XX;dec2bin(i,n)];
end

for j=1:(2^n)
    for k=1:n
        X(j,k)=str2num(XX(j,k));
    end
end

for a=(1:(2^n))
    for h=1:m
        y(h,:)= X(a,:) & V(h,:);
        t0(h)= max (y(h,:));
    end
    t= min (t0);
    if t==0
        C=[C;X(a,:)];
    end
    if t==1
        P=[P;X(a,:)];
    end
end
end

```

### *Appendix C. Nodal Probabilities for Complex EON*

This appendix shows the calculations used to find the nodal probabilities for the complex system shown in Figures 20 and 21 on page 76. For this system assume that component  $i$ 's lifetime is exponentially distributed with rate  $\lambda_i$  for  $i = 1, \dots, 5$ . Additionally assume that the components fail independently of each other.

#### **Tier Zero**

For the first node, the non-event,

$$\begin{aligned} P_1(t) &= P \{E_1 > t, E_2 > t, E_3 > t, E_4 > t, E_5 > t\} \\ &= e^{-(\sum_{i=1}^5 \lambda_i)t}. \end{aligned}$$

#### **Tier One**

For node  $j + 1$ ,  $j = 1, \dots, 5$  on the first tier

$$\begin{aligned} P_{j+1}(t) &= P \{E_j < t, E_i > t\} \quad \text{for } i = 1, \dots, 5; i \neq j \\ &= (1 - e^{-\lambda_j t}) e^{-(\sum_{i=1, i \neq j}^5 \lambda_i)t}. \end{aligned}$$

As an example,

$$\begin{aligned} P_2(t) &= P \{E_1 < t, E_2 > t, E_3 > t, E_4 > t, E_5 > t\} \\ &= (1 - e^{-\lambda_1 t}) e^{-(\sum_{i=2}^5 \lambda_i)t}. \end{aligned}$$

#### **Tier Two**

The probability expressions for the nodes on the second tier are all similar, with the exception of node ten which represents the first terminating node in this particular EON. Node ten represents the event stream where both components one and two have failed and thus the system is in a failed state, its probability expression is given

as

$$\begin{aligned}
P_{10}(t) &= P \{E_1 < E_2, E_2 < E_3, E_2 < E_4, E_2 < E_5 | T \leq t\} \\
&\quad + P \{E_2 < E_1, E_1 < E_3, E_1 < E_4, E_1 < E_5 | T \leq t\} \\
&= \int_0^t P \{E_1 < x\} P \{E_3 > x\} P \{E_4 > x\} P \{E_5 > x\} f_{E_2}(x) dx \\
&\quad + \int_0^t P \{E_2 < y\} P \{E_3 > y\} P \{E_4 > y\} P \{E_5 > y\} f_{E_1}(y) dy \\
&= \lambda_2 \int_0^t (1 - e^{-\lambda_1 x}) e^{-(\sum_{i=2}^5 \lambda_i)x} dx \\
&\quad + \lambda_1 \int_0^t (1 - e^{-\lambda_2 y}) e^{-(\sum_{i=1; i \neq 2}^5 \lambda_i)y} dy \\
&= \lambda_2 \int_0^t e^{-(\sum_{i=2}^5 \lambda_i)x} - e^{-(\sum_{i=1}^5 \lambda_i)x} dx \\
&\quad + \lambda_1 \int_0^t e^{-(\sum_{i=1; i \neq 2}^5 \lambda_i)y} - e^{-(\sum_{i=1}^5 \lambda_i)y} dy \\
&= \frac{\lambda_2 \left(1 - e^{-(\sum_{i=2}^5 \lambda_i)t}\right)}{\sum_{i=2}^5 \lambda_i} + \frac{\lambda_2 \left(e^{-(\sum_{i=1}^5 \lambda_i)t} - 1\right)}{\sum_{i=1}^5 \lambda_i} \\
&\quad + \frac{\lambda_1 \left(1 - e^{-(\sum_{i=1; i \neq 2}^5 \lambda_i)t}\right)}{\sum_{i=1; i \neq 2}^5 \lambda_i} + \frac{\lambda_1 \left(e^{-(\sum_{i=1}^5 \lambda_i)t} - 1\right)}{\sum_{i=1}^5 \lambda_i}.
\end{aligned}$$

The remainder of the nodes on the second tier are transient and represent event streams where two components have failed, but the system is still in an operational state. In general, the probability expression for node  $m$ , an intermediate node on this tier, if components  $a$  and  $b$  have failed, is given as

$$\begin{aligned}
P_m(t) &= P \{E_a < t, E_b < t, E_k > t\} \quad \text{for } k = 1, \dots, 5; k \neq a, b \\
&= \prod_{i=a,b} (1 - e^{-\lambda_i t}) e^{-(\sum_{j=1; j \neq a,b}^5 \lambda_j)t}. \tag{15}
\end{aligned}$$

The expressions for these nodes are found using Equation (15) and are shown below:

$$\begin{aligned}
P_7(t) &= P \{E_1 < t, E_3 < t, E_k > t\} \quad \text{for } k = 1, \dots, 5; k \neq 1, 3 \\
&= \prod_{i=1,3} (1 - e^{-\lambda_i t}) e^{-(\sum_{j=1; j \neq 1,3}^5 \lambda_j)t};
\end{aligned}$$

$$\begin{aligned}
P_8(t) &= P \{E_1 < t, E_4 < t, E_k > t\} \quad \text{for } k = 1, \dots, 5; k \neq 1, 4 \\
&= \prod_{i=1,4} (1 - e^{-\lambda_i t}) e^{-(\sum_{j=1; j \neq 1,4}^5 \lambda_j)t};
\end{aligned}$$

$$\begin{aligned}
P_9(t) &= P \{E_1 < t, E_5 < t, E_k > t\} \quad \text{for } k = 1, \dots, 5; k \neq 1, 5 \\
&= \prod_{i=1,5} (1 - e^{-\lambda_i t}) e^{-(\sum_{j=1; j \neq 1,5}^5 \lambda_j)t};
\end{aligned}$$

$$\begin{aligned}
P_{11}(t) &= P \{E_2 < t, E_3 < t, E_k > t\} \quad \text{for } k = 1, \dots, 5; k \neq 2, 3 \\
&= \prod_{i=2,3} (1 - e^{-\lambda_i t}) e^{-(\sum_{j=1; j \neq 2,3}^5 \lambda_j)t};
\end{aligned}$$

$$\begin{aligned}
P_{12}(t) &= P \{E_2 < t, E_4 < t, E_k > t\} \quad \text{for } k = 1, \dots, 5; k \neq 2, 4 \\
&= \prod_{i=2,4} (1 - e^{-\lambda_i t}) e^{-(\sum_{j=1; j \neq 2,4}^5 \lambda_j)t};
\end{aligned}$$

$$\begin{aligned}
P_{13}(t) &= P \{E_2 < t, E_5 < t, E_k > t\} \quad \text{for } k = 1, \dots, 5; k \neq 2, 5 \\
&= \prod_{i=2,5} (1 - e^{-\lambda_i t}) e^{-(\sum_{j=1; j \neq 2,5}^5 \lambda_j)t};
\end{aligned}$$

$$\begin{aligned}
P_{14}(t) &= P\{E_3 < t, E_4 < t, E_k > t\} \quad \text{for } k = 1, \dots, 5; k \neq 3, 4 \\
&= \prod_{i=3,4} (1 - e^{-\lambda_i t}) e^{-(\sum_{j=1; j \neq 3,4}^5 \lambda_j)t},
\end{aligned}$$

$$\begin{aligned}
P_{15}(t) &= P\{E_3 < t, E_5 < t, E_k > t\} \quad \text{for } k = 1, \dots, 5; k \neq 3, 5 \\
&= \prod_{i=3,5} (1 - e^{-\lambda_i t}) e^{-(\sum_{j=1; j \neq 3,5}^5 \lambda_j)t},
\end{aligned}$$

$$\begin{aligned}
P_{16}(t) &= P\{E_4 < t, E_5 < t, E_k > t\} \quad \text{for } k = 1, \dots, 5; k \neq 4, 5 \\
&= \prod_{i=4,5} (1 - e^{-\lambda_i t}) e^{-(\sum_{j=1; j \neq 4,5}^5 \lambda_j)t}.
\end{aligned}$$

### **Tier Three**

The next tier consists of event streams where three different events have occurred. Each node has either two or three paths coming into it. Nodes with only two paths (17, 20 and 22) are missing the path from parent node ten, which is not feasible since ten is an terminating node.

The terminating nodes in this tier (nodes 17, 20-23, and 26), represent specific sequences of component failures that eventually lead to system failure at this tier. To simplify matters a generic sequential failure sequence is analyzed. In general the probability of component  $a$  failing first followed by component  $b$ , followed by

component  $c$  where component  $d$  and  $e$  have not yet failed, is given as

$$\begin{aligned}
& P \{E_a < E_b, E_b < E_c, E_c < E_d, E_c < E_e | T \leq t\} \\
&= \int_0^t \int_0^y P \{E_a < x\} P \{E_d > y\} P \{E_e > y\} f_{E_b}(x) dx f_{E_c}(y) dy \\
&= \lambda_b \lambda_c \int_0^t \int_0^y (1 - e^{-\lambda_a x}) e^{-(\lambda_c + \lambda_d + \lambda_e)y} e^{-\lambda_e x} dx dy \\
&= \lambda_b \lambda_c \int_0^t \int_0^y (e^{-\lambda_b x} - e^{-(\lambda_a + \lambda_b)x}) e^{-(\lambda_c + \lambda_d + \lambda_e)y} dx dy \\
&= \lambda_b \lambda_c \int_0^t \left( \frac{1}{\lambda_b} (1 - e^{-\lambda_b y}) + \frac{1}{\lambda_a + \lambda_b} (e^{-(\lambda_a + \lambda_b)y} - 1) \right) e^{-(\lambda_c + \lambda_d + \lambda_e)y} dy \\
&= \lambda_c \int_0^t (e^{-(\lambda_c + \lambda_d + \lambda_e)y} - e^{-(\lambda_b + \lambda_c + \lambda_d + \lambda_e)y}) dy \\
&\quad + \frac{\lambda_b \lambda_c}{\lambda_1 + \lambda_2} \int_0^t (e^{-(\lambda_a + \lambda_b + \lambda_c + \lambda_d + \lambda_e)y} - e^{-(\lambda_c + \lambda_d + \lambda_e)y}) dy \\
&= \frac{\lambda_c}{\lambda_c + \lambda_d + \lambda_e} (1 - e^{-(\lambda_c + \lambda_d + \lambda_e)t}) + \frac{\lambda_c}{\lambda_b + \lambda_c + \lambda_d + \lambda_e} (e^{-(\lambda_b + \lambda_c + \lambda_d + \lambda_e)t} - 1) \\
&\quad + \frac{\lambda_b \lambda_c}{\lambda_a + \lambda_b} \left( \frac{1 - e^{-(\lambda_a + \lambda_b + \lambda_c + \lambda_d + \lambda_e)t}}{\lambda_a + \lambda_b + \lambda_c + \lambda_d + \lambda_e} + \frac{e^{-(\lambda_c + \lambda_d + \lambda_e)t} - 1}{\lambda_c + \lambda_d + \lambda_e} \right). \tag{16}
\end{aligned}$$

The expressions for the terminating nodes can now be expressed by plugging the relevant failure sequences into Equation (16). As stated before nodes 17, 20 and 22 only have two different paths from parent nodes in tier two, yielding a total of four different possible event stream combinations that conclude at these nodes. The remaining concluding nodes on tier three, nodes 21, 23 and 26, have three different paths from their respective parent nodes, yielding a total of six possible event stream combinations leading to these nodes. This means that each possible failure sequence must be substituted into Equation (16) for each terminating node and these results

summed to obtain total node probability. For example

$$\begin{aligned}
P_{17}(t) &= P \{E_1 < E_3, E_3 < E_2, E_2 < E_4, E_2 < E_5 | T \leq t\} \\
&\quad + P \{E_3 < E_1, E_1 < E_2, E_2 < E_4, E_2 < E_5 | T \leq t\} \\
&\quad + P \{E_2 < E_3, E_3 < E_1, E_1 < E_4, E_1 < E_5 | T \leq t\} \\
&\quad + P \{E_3 < E_2, E_2 < E_1, E_1 < E_4, E_1 < E_5 | T \leq t\} \\
&= \frac{\lambda_2}{\lambda_2 + \lambda_4 + \lambda_5} (1 - e^{-(\lambda_2 + \lambda_4 + \lambda_5)t}) + \frac{\lambda_2}{\lambda_2 + \lambda_3 + \lambda_4 + \lambda_5} (e^{-(\lambda_2 + \lambda_3 + \lambda_4 + \lambda_5)t} - 1) \\
&\quad + \frac{\lambda_2 \lambda_3}{\lambda_1 + \lambda_3} \left( \frac{1 - e^{-(\lambda_1 + \lambda_2 + \lambda_3 + \lambda_4 + \lambda_5)t}}{\lambda_1 + \lambda_2 + \lambda_3 + \lambda_4 + \lambda_5} + \frac{e^{-(\lambda_2 + \lambda_4 + \lambda_5)t} - 1}{\lambda_2 + \lambda_4 + \lambda_5} \right) \\
&\quad + \frac{\lambda_2}{\lambda_2 + \lambda_4 + \lambda_5} (1 - e^{-(\lambda_2 + \lambda_4 + \lambda_5)t}) + \frac{\lambda_2}{\lambda_1 + \lambda_2 + \lambda_4 + \lambda_5} (e^{-(\lambda_1 + \lambda_2 + \lambda_4 + \lambda_5)t} - 1) \\
&\quad + \frac{\lambda_1 \lambda_2}{\lambda_1 + \lambda_3} \left( \frac{1 - e^{-(\lambda_1 + \lambda_2 + \lambda_3 + \lambda_4 + \lambda_5)t}}{\lambda_1 + \lambda_2 + \lambda_3 + \lambda_4 + \lambda_5} + \frac{e^{-(\lambda_2 + \lambda_4 + \lambda_5)t} - 1}{\lambda_2 + \lambda_4 + \lambda_5} \right) \\
&\quad + \frac{\lambda_1}{\lambda_1 + \lambda_4 + \lambda_5} (1 - e^{-(\lambda_1 + \lambda_4 + \lambda_5)t}) + \frac{\lambda_1}{\lambda_1 + \lambda_3 + \lambda_4 + \lambda_5} (e^{-(\lambda_1 + \lambda_3 + \lambda_4 + \lambda_5)t} - 1) \\
&\quad + \frac{\lambda_1 \lambda_3}{\lambda_2 + \lambda_3} \left( \frac{1 - e^{-(\lambda_1 + \lambda_2 + \lambda_3 + \lambda_4 + \lambda_5)t}}{\lambda_1 + \lambda_2 + \lambda_3 + \lambda_4 + \lambda_5} + \frac{e^{-(\lambda_1 + \lambda_4 + \lambda_5)t} - 1}{\lambda_1 + \lambda_4 + \lambda_5} \right) \\
&\quad + \frac{\lambda_1}{\lambda_1 + \lambda_4 + \lambda_5} (1 - e^{-(\lambda_1 + \lambda_4 + \lambda_5)t}) + \frac{\lambda_1}{\lambda_1 + \lambda_2 + \lambda_4 + \lambda_5} (e^{-(\lambda_1 + \lambda_2 + \lambda_4 + \lambda_5)t} - 1) \\
&\quad + \frac{\lambda_1 \lambda_2}{\lambda_2 + \lambda_3} \left( \frac{1 - e^{-(\lambda_1 + \lambda_2 + \lambda_3 + \lambda_4 + \lambda_5)t}}{\lambda_1 + \lambda_2 + \lambda_3 + \lambda_4 + \lambda_5} + \frac{e^{-(\lambda_1 + \lambda_4 + \lambda_5)t} - 1}{\lambda_1 + \lambda_4 + \lambda_5} \right).
\end{aligned}$$

This substitution can be applied to the remainder of the nodes on this tier as well, but is not shown in an effort to save space. The expressions for the remainder of the terminating nodes are:

$$\begin{aligned}
P_{20}(t) &= P \{E_1 < E_4, E_4 < E_2, E_2 < E_3, E_2 < E_5 | T \leq t\} \\
&\quad + P \{E_4 < E_1, E_1 < E_2, E_2 < E_3, E_2 < E_5 | T \leq t\} \\
&\quad + P \{E_2 < E_4, E_4 < E_1, E_1 < E_3, E_1 < E_5 | T \leq t\} \\
&\quad + P \{E_4 < E_2, E_2 < E_1, E_1 < E_3, E_1 < E_5 | T \leq t\};
\end{aligned}$$

$$\begin{aligned}
P_{21}(t) &= P \{E_1 < E_4, E_4 < E_5, E_5 < E_2, E_5 < E_3 | T \leq t\} \\
&+ P \{E_4 < E_1, E_1 < E_5, E_5 < E_2, E_5 < E_3 | T \leq t\} \\
&+ P \{E_1 < E_5, E_5 < E_4, E_4 < E_2, E_4 < E_3 | T \leq t\} \\
&+ P \{E_5 < E_1, E_1 < E_4, E_4 < E_2, E_4 < E_3 | T \leq t\} \\
&+ P \{E_4 < E_5, E_5 < E_1, E_1 < E_2, E_1 < E_3 | T \leq t\} \\
&+ P \{E_5 < E_4, E_4 < E_1, E_1 < E_2, E_1 < E_3 | T \leq t\};
\end{aligned}$$

$$\begin{aligned}
P_{22}(t) &= P \{E_1 < E_5, E_5 < E_2, E_2 < E_3, E_2 < E_4 | T \leq t\} \\
&+ P \{E_5 < E_1, E_1 < E_2, E_2 < E_3, E_2 < E_4 | T \leq t\} \\
&+ P \{E_2 < E_5, E_5 < E_1, E_1 < E_3, E_1 < E_4 | T \leq t\} \\
&+ P \{E_5 < E_2, E_2 < E_1, E_1 < E_3, E_1 < E_4 | T \leq t\};
\end{aligned}$$

$$\begin{aligned}
P_{23}(t) &= P \{E_2 < E_3, E_3 < E_4, E_4 < E_1, E_4 < E_5 | T \leq t\} \\
&+ P \{E_3 < E_2, E_2 < E_4, E_4 < E_1, E_4 < E_5 | T \leq t\} \\
&+ P \{E_2 < E_4, E_4 < E_3, E_3 < E_1, E_3 < E_5 | T \leq t\} \\
&+ P \{E_4 < E_2, E_2 < E_3, E_3 < E_1, E_3 < E_5 | T \leq t\} \\
&+ P \{E_3 < E_4, E_4 < E_2, E_2 < E_1, E_2 < E_5 | T \leq t\} \\
&+ P \{E_4 < E_3, E_3 < E_2, E_2 < E_1, E_2 < E_5 | T \leq t\};
\end{aligned}$$

and

$$\begin{aligned}
P_{26}(t) &= P \{E_3 < E_4, E_4 < E_5, E_5 < E_1, E_5 < E_2 | T \leq t\} \\
&+ P \{E_4 < E_3, E_3 < E_5, E_5 < E_1, E_5 < E_2 | T \leq t\} \\
&+ P \{E_4 < E_5, E_5 < E_3, E_3 < E_1, E_3 < E_2 | T \leq t\} \\
&+ P \{E_5 < E_4, E_4 < E_3, E_3 < E_1, E_3 < E_2 | T \leq t\} \\
&+ P \{E_3 < E_5, E_5 < E_4, E_4 < E_1, E_4 < E_2 | T \leq t\} \\
&+ P \{E_5 < E_3, E_3 < E_4, E_4 < E_1, E_4 < E_2 | T \leq t\}.
\end{aligned}$$

The intermediate nodes in this tier, nodes 18, 19, 24 and 25 are much easier to analyze. They represent event streams where three components have failed but the system is still in an operational state. Their nodal probabilities are

$$\begin{aligned}
P_{18}(t) &= P \{E_1 < t, E_3 < t, E_4 < t, E_2 > t, E_5 > t\} \\
&= (1 - e^{-\lambda_1 t}) (1 - e^{-\lambda_3 t}) (1 - e^{-\lambda_4 t}) e^{-(\lambda_2 + \lambda_5)t},
\end{aligned}$$

$$\begin{aligned}
P_{19}(t) &= P \{E_1 < t, E_3 < t, E_5 < t, E_2 > t, E_4 > t\} \\
&= (1 - e^{-\lambda_1 t}) (1 - e^{-\lambda_3 t}) (1 - e^{-\lambda_5 t}) e^{-(\lambda_2 + \lambda_4)t},
\end{aligned}$$

$$\begin{aligned}
P_{24}(t) &= P \{E_2 < t, E_3 < t, E_5 < t, E_1 > t, E_4 > t\} \\
&= (1 - e^{-\lambda_2 t}) (1 - e^{-\lambda_3 t}) (1 - e^{-\lambda_5 t}) e^{-(\lambda_1 + \lambda_4)t},
\end{aligned}$$

and

$$\begin{aligned}
P_{25}(t) &= P \{E_2 < t, E_4 < t, E_5 < t, E_1 > t, E_3 > t\} \\
&= (1 - e^{-\lambda_2 t}) (1 - e^{-\lambda_4 t}) (1 - e^{-\lambda_5 t}) e^{-(\lambda_1 + \lambda_3)t}.
\end{aligned}$$

### Tier Four

Tier four being the last tier in this particular EON is comprised solely of terminating nodes. Each node represents the failure of four different components. The nodes with only one parent node in the previous tier, nodes 28 and 31, have a total of six possible component failure sequences leading to them, while the remaining nodes have a total of twelve different component failure sequences. Once again, as was done in tier three, a generic failure sequence is analyzed to simplify the calculation of the nodal probabilities for this tier. Consider the case when component  $a$  fails first, followed by  $b$ ,  $c$ , then  $d$ , leaving component  $e$  as the only one that has not failed. The probability of this event sequence is given as

$$\begin{aligned}
& P \{E_a < E_b, E_b < E_c, E_c < E_d, E_d < E_e | T \leq t\} \\
&= \int_0^t \int_0^z \int_0^y P \{E_a < x\} P \{E_e > z\} f_{E_b}(x) dx f_{E_c}(y) dy f_{E_d}(z) dz \\
&= \lambda_b \lambda_c \lambda_d \int_0^t \int_0^z \int_0^y (1 - e^{-\lambda_a x}) e^{-(\lambda_d + \lambda_e)z} e^{-\lambda_b x} e^{-\lambda_c y} dx dy dz \\
&= \lambda_b \lambda_c \lambda_d \int_0^t \int_0^z \int_0^y (e^{-\lambda_b x} - e^{-(\lambda_a + \lambda_b)x}) e^{-\lambda_c y} e^{-(\lambda_d + \lambda_e)z} dx dy dz \\
&= \lambda_c \lambda_d \int_0^t \int_0^z \left( 1 - e^{-\lambda_b y} + \frac{\lambda_b}{\lambda_a + \lambda_b} (e^{-(\lambda_a + \lambda_b)y} - 1) \right) e^{-\lambda_c y} e^{-(\lambda_d + \lambda_e)z} dy dz \\
&= \lambda_c \lambda_d \int_0^t \int_0^z \left( e^{-\lambda_c y} - e^{-(\lambda_b + \lambda_c)y} + \frac{\lambda_b}{\lambda_a + \lambda_b} (e^{-(\lambda_a + \lambda_b + \lambda_c)y} - e^{-\lambda_c y}) \right) e^{-(\lambda_d + \lambda_e)z} dy dz \\
&= \lambda_d \int_0^t \left( 1 - e^{-\lambda_c z} + \frac{\lambda_c}{\lambda_b + \lambda_c} (e^{-(\lambda_b + \lambda_c)z} - 1) \right. \\
&\quad \left. + \frac{\lambda_b \lambda_c}{\lambda_a + \lambda_b} \left( \frac{1 - e^{-(\lambda_a + \lambda_b + \lambda_c)z}}{\lambda_a + \lambda_b + \lambda_c} + \frac{e^{-\lambda_c z} - 1}{\lambda_c} \right) \right) e^{-(\lambda_d + \lambda_e)z} dz.
\end{aligned}$$

Splitting up these expressions into a sum of separate integrals gives

$$\begin{aligned}
&= \lambda_d \int_0^t e^{-(\lambda_d+\lambda_e)z} dz - \lambda_d \int_0^t e^{-(\lambda_c+\lambda_d+\lambda_e)z} dz + \frac{\lambda_c \lambda_d}{\lambda_b + \lambda_c} \int_0^t e^{-(\lambda_b+\lambda_c+\lambda_d+\lambda_e)z} dz \\
&\quad - \frac{\lambda_c \lambda_d}{\lambda_b + \lambda_c} \int_0^t e^{-(\lambda_d+\lambda_e)z} dz + \frac{\lambda_b \lambda_c \lambda_d}{(\lambda_a + \lambda_b)(\lambda_a + \lambda_b + \lambda_c)} \int_0^t e^{-(\lambda_d+\lambda_e)z} dz \\
&\quad - \frac{\lambda_b \lambda_c \lambda_d}{(\lambda_a + \lambda_b)(\lambda_a + \lambda_b + \lambda_c)} \int_0^t e^{-(\lambda_a+\lambda_b+\lambda_c+\lambda_d+\lambda_e)z} dz + \frac{\lambda_b \lambda_d}{\lambda_a + \lambda_b} \int_0^t e^{-(\lambda_c+\lambda_d+\lambda_e)z} dz \\
&\quad - \frac{\lambda_b \lambda_d}{\lambda_a + \lambda_b} \int_0^t e^{-(\lambda_d+\lambda_e)z} dz \\
&= \left( \lambda_d - \frac{\lambda_c \lambda_d}{\lambda_b + \lambda_c} + \frac{\lambda_b \lambda_c \lambda_d}{(\lambda_a + \lambda_b)(\lambda_a + \lambda_b + \lambda_c)} - \frac{\lambda_b \lambda_d}{\lambda_a + \lambda_b} \right) \int_0^t e^{-(\lambda_d+\lambda_e)z} dz \\
&\quad + \left( \frac{\lambda_b \lambda_d}{\lambda_a + \lambda_b} - \lambda_d \right) \int_0^t e^{-(\lambda_c+\lambda_d+\lambda_e)z} dz + \frac{\lambda_c \lambda_d}{\lambda_b + \lambda_c} \int_0^t e^{-(\lambda_b+\lambda_c+\lambda_d+\lambda_e)z} dz \\
&\quad - \frac{\lambda_b \lambda_c \lambda_d}{(\lambda_a + \lambda_b)(\lambda_a + \lambda_b + \lambda_c)} \int_0^t e^{-(\lambda_a+\lambda_b+\lambda_c+\lambda_d+\lambda_e)z} dz.
\end{aligned}$$

Which finally yields the desired solution

$$\begin{aligned}
&= \left( \lambda_d - \frac{\lambda_c \lambda_d}{\lambda_b + \lambda_c} + \frac{\lambda_b \lambda_c \lambda_d}{(\lambda_a + \lambda_b)(\lambda_a + \lambda_b + \lambda_c)} - \frac{\lambda_b \lambda_d}{\lambda_a + \lambda_b} \right) \left( \frac{1 - e^{-(\lambda_d+\lambda_e)t}}{\lambda_d + \lambda_e} \right) \\
&\quad + \left( \frac{\lambda_b \lambda_d}{\lambda_a + \lambda_b} - \lambda_d \right) \left( \frac{1 - e^{-(\lambda_c+\lambda_d+\lambda_e)t}}{\lambda_c + \lambda_d + \lambda_e} \right) \\
&\quad + \left( \frac{\lambda_c \lambda_d}{\lambda_b + \lambda_c} \right) \left( \frac{1 - e^{-(\lambda_b+\lambda_c+\lambda_d+\lambda_e)t}}{\lambda_b + \lambda_c + \lambda_d + \lambda_e} \right) \\
&\quad + \left( \frac{\lambda_b \lambda_c \lambda_d}{(\lambda_a + \lambda_b)(\lambda_a + \lambda_b + \lambda_c)} \right) \left( \frac{e^{-(\lambda_a+\lambda_b+\lambda_c+\lambda_d+\lambda_e)t} - 1}{\lambda_a + \lambda_b + \lambda_c + \lambda_d + \lambda_e} \right). \tag{17}
\end{aligned}$$

Now as was done previously, the different failure sequences that pertain to a particular node are substituted into Equation (17) and then summed in order to obtain

the probability of being at that node at time  $t$ . The different expressions are

$$\begin{aligned}
P_{27}(t) = & P \{E_1 < E_3, E_3 < E_4, E_4 < E_5, E_5 < E_2\} \\
& + P \{E_3 < E_1, E_1 < E_4, E_4 < E_5, E_5 < E_2\} \\
& + P \{E_4 < E_1, E_1 < E_3, E_3 < E_5, E_5 < E_2\} \\
& + P \{E_4 < E_3, E_3 < E_1, E_1 < E_5, E_5 < E_2\} \\
& + P \{E_3 < E_4, E_4 < E_1, E_1 < E_5, E_5 < E_2\} \\
& + P \{E_1 < E_4, E_4 < E_3, E_3 < E_5, E_5 < E_2\} \\
& + P \{E_1 < E_3, E_3 < E_5, E_5 < E_4, E_4 < E_2\} \\
& + P \{E_1 < E_5, E_5 < E_3, E_3 < E_4, E_4 < E_2\} \\
& + P \{E_3 < E_1, E_1 < E_5, E_5 < E_4, E_4 < E_2\} \\
& + P \{E_3 < E_5, E_5 < E_1, E_1 < E_4, E_4 < E_2\} \\
& + P \{E_5 < E_1, E_1 < E_3, E_3 < E_4, E_4 < E_2\} \\
& + P \{E_5 < E_3, E_3 < E_1, E_1 < E_4, E_4 < E_2\},
\end{aligned}$$

$$\begin{aligned}
P_{28}(t) = & P \{E_1 < E_3, E_3 < E_4, E_4 < E_2, E_2 < E_5\} \\
& + P \{E_1 < E_4, E_4 < E_3, E_3 < E_2, E_2 < E_5\} \\
& + P \{E_3 < E_1, E_1 < E_4, E_4 < E_2, E_2 < E_5\} \\
& + P \{E_4 < E_1, E_1 < E_3, E_3 < E_2, E_2 < E_5\} \\
& + P \{E_3 < E_4, E_4 < E_1, E_1 < E_2, E_2 < E_5\} \\
& + P \{E_4 < E_3, E_3 < E_1, E_1 < E_2, E_2 < E_5\},
\end{aligned}$$

$$\begin{aligned}
P_{29}(t) = & P \{E_2 < E_3, E_3 < E_5, E_5 < E_1, E_1 < E_4\} \\
& + P \{E_2 < E_5, E_5 < E_3, E_3 < E_1, E_1 < E_4\} \\
& + P \{E_5 < E_2, E_2 < E_3, E_3 < E_1, E_1 < E_4\} \\
& + P \{E_5 < E_3, E_3 < E_2, E_2 < E_1, E_1 < E_4\} \\
& + P \{E_3 < E_2, E_2 < E_5, E_5 < E_1, E_1 < E_4\} \\
& + P \{E_3 < E_5, E_5 < E_2, E_2 < E_1, E_1 < E_4\} \\
& + P \{E_1 < E_3, E_3 < E_5, E_5 < E_2, E_2 < E_4\} \\
& + P \{E_1 < E_5, E_5 < E_3, E_3 < E_2, E_2 < E_4\} \\
& + P \{E_3 < E_1, E_1 < E_5, E_5 < E_2, E_2 < E_4\} \\
& + P \{E_3 < E_5, E_5 < E_1, E_1 < E_2, E_2 < E_4\} \\
& + P \{E_5 < E_1, E_1 < E_3, E_3 < E_2, E_2 < E_4\} \\
& + P \{E_5 < E_3, E_3 < E_1, E_1 < E_2, E_2 < E_4\},
\end{aligned}$$

$$\begin{aligned}
P_{30}(t) = & P \{E_2 < E_4, E_4 < E_5, E_5 < E_3, E_3 < E_1\} \\
& + P \{E_2 < E_5, E_5 < E_4, E_4 < E_3, E_3 < E_1\} \\
& + P \{E_4 < E_2, E_2 < E_5, E_5 < E_3, E_3 < E_1\} \\
& + P \{E_4 < E_5, E_5 < E_2, E_2 < E_3, E_3 < E_1\} \\
& + P \{E_5 < E_4, E_4 < E_2, E_2 < E_3, E_3 < E_1\} \\
& + P \{E_5 < E_2, E_2 < E_4, E_4 < E_3, E_3 < E_1\} \\
& + P \{E_2 < E_3, E_3 < E_5, E_5 < E_4, E_4 < E_1\} \\
& + P \{E_2 < E_5, E_5 < E_3, E_3 < E_4, E_4 < E_1\} \\
& + P \{E_3 < E_5, E_5 < E_2, E_2 < E_4, E_4 < E_1\} \\
& + P \{E_3 < E_2, E_2 < E_5, E_5 < E_4, E_4 < E_1\} \\
& + P \{E_5 < E_2, E_2 < E_3, E_3 < E_4, E_4 < E_1\} \\
& + P \{E_5 < E_3, E_3 < E_2, E_2 < E_4, E_4 < E_1\},
\end{aligned}$$

and finally

$$\begin{aligned} P_{31}(t) = & P \{E_2 < E_4, E_4 < E_5, E_5 < E_1, E_1 < E_3\} \\ & + P \{E_2 < E_5, E_5 < E_4, E_4 < E_1, E_1 < E_3\} \\ & + P \{E_4 < E_2, E_2 < E_5, E_5 < E_1, E_1 < E_3\} \\ & + P \{E_4 < E_5, E_5 < E_2, E_2 < E_1, E_1 < E_3\} \\ & + P \{E_5 < E_2, E_2 < E_4, E_4 < E_1, E_1 < E_3\} \\ & + P \{E_5 < E_4, E_4 < E_2, E_2 < E_1, E_1 < E_3\}. \end{aligned}$$

*Appendix D. Nodal Probabilities for Availability Graph with 2  
Components in Series*

This appendix shows the calculations used to find the nodal probabilities for the system shown in Figure 22. For this system assume that component  $i$ 's life and repair time are exponentially distributed with rates  $\lambda_i$  and  $\mu_i$  respectively for  $i = 1, 2$ . Additionally assume that the component life and repair times are independent, and that the components are repaired to a *good as new* state. It must also be assumed that the components do not fail or wear when the system is in a failed state. This example is also constrained in that only one repair event is allowed to take place. With this constraint in mind, this analysis assumes that the life and repair rates do not change for each failure and repair, however the same technique can be used in the case where the failure and repair rates do change in subsequent failures and repairs. With these assumptions and limitations in mind, the probability for being at node  $i$  at any time  $t$ ,  $P_i(t)$ ,  $i = 1, \dots, 12$ , is derived next. In these derivations, due to the symmetry in the given problem, the nodal probabilities will only be computed for the nodes on the left hand side of the availability graph. Following each derivation, the substitutions necessary to obtain the probability expressions for the nodes on the right hand side will be stated and their associated probabilities explicitly written.

In finding the specific nodal probabilities for this system it is useful to first solve the following integral expressions for a general parameter  $\gamma$ :

$$\begin{aligned}
 \int_0^t ze^{-\gamma z} dz &= -\frac{ze^{-\gamma z}}{\gamma} \Big|_0^t - \int_0^t \frac{-e^{-\gamma z}}{\gamma} dz \quad (\text{via integration by parts}) \\
 &= -\frac{ze^{-\gamma z}}{\gamma} \Big|_0^t - \frac{e^{-\gamma z}}{\gamma^2} \Big|_0^t \\
 &= -\frac{te^{-\gamma t}}{\gamma} + \frac{1 - e^{-\gamma t}}{\gamma^2} \\
 &= \frac{1 - e^{-\gamma t} - \gamma te^{-\gamma t}}{\gamma^2} \\
 &= \frac{1 - e^{-\gamma t}(\gamma t + 1)}{\gamma^2}; \tag{18}
 \end{aligned}$$

and

$$\begin{aligned}
\int_0^t z^2 e^{-\gamma z} dz &= -\frac{z^2 e^{-\gamma z}}{\gamma} \Big|_0^t - \int_0^t \frac{-2z e^{-\gamma z}}{\gamma} dz \quad (\text{via integration by parts}) \\
&= -\frac{t^2 e^{-\gamma t}}{\gamma} + \frac{2 - 2e^{-\gamma t}(\gamma t + 1)}{\gamma^3} \quad (\text{equation (18)}) \\
&= \frac{2 - \gamma^2 t^2 e^{-\gamma t} - 2e^{-\gamma t}(\gamma t + 1)}{\gamma^3} \\
&= \frac{2 - e^{-\gamma t}(\gamma^2 t^2 + 2\gamma t + 2)}{\gamma^3}. \tag{19}
\end{aligned}$$

### Tier Zero

For the first node, the non-event,

$$\begin{aligned}
P_1(t) &= P \{E_{11} > t, E_{21} > t\} \\
&= e^{-(\lambda_1 + \lambda_2)t}.
\end{aligned}$$

### Tier One

Node two represents the event stream where component one has failed for the first time and not yet been repaired. Its probability is given as

$$\begin{aligned}
P_2(t) &= P \{E_{11} < E_{21} | T \leq t, E_{11} + R_{11} > t\} \\
&= \int_0^t P \{E_{21} > x\} P \{R_{11} > t - x\} f_{E_{11}}(x) dx \\
&= \lambda_1 e^{-\mu_1 t} \int_0^t e^{(\mu_1 - \lambda_1 - \lambda_2)x} dx \\
&= \left( \frac{\lambda_1}{\mu_1 - \lambda_1 - \lambda_2} \right) (e^{-(\lambda_1 + \lambda_2)t} - e^{-\mu_1 t}).
\end{aligned}$$

Similarly, the expression for the probability of being at node three at time  $t$ , is the same where  $\lambda_2$  and  $\mu_2$  replace  $\lambda_1$  and  $\mu_1$  respectively.

$$\begin{aligned} P_3(t) &= P \{E_{21} < E_{11} | T \leq t, E_{21} + R_{21} > t\} \\ &= \left( \frac{\lambda_2}{\mu_2 - \lambda_1 - \lambda_2} \right) (e^{-(\lambda_1 + \lambda_2)t} - e^{-\mu_2 t}). \end{aligned}$$

### Tier Two

The nodes on tier two represent event streams where a component has failed and been repaired by time  $t$ . More specifically, node four represents this exact scenario for component one. Its probability is

$$\begin{aligned} P_4(t) &= P \{E_{11} + R_{11} < t, E_{21} + R_{11} > t, E_{11} + E_{12} + R_{11} > t\} \\ &= \int_0^t \int_0^{t-r} P \{E_{21} > t - r\} P \{E_{12} > t - x - r\} f_{E_{11}}(x) dx f_{R_{11}}(r) dr \\ &= \lambda_1 \mu_1 e^{-(\lambda_1 + \lambda_2)t} \int_0^t \int_0^{t-r} e^{(\lambda_1 + \lambda_2 - \mu_1)r} dx dr \\ &= \lambda_1 \mu_1 e^{-(\lambda_1 + \lambda_2)t} \int_0^t (t - r) e^{(\lambda_1 + \lambda_2 - \mu_1)r} dx dr \\ &= \lambda_1 \mu_1 \left( \frac{te^{-\mu_1 t} - te^{-(\lambda_1 + \lambda_2)t}}{\lambda_1 + \lambda_2 - \mu_1} + \frac{e^{-\mu_1 t} ((\mu_1 - \lambda_1 - \lambda_2)t + 1) - e^{-(\lambda_1 + \lambda_2)t}}{(\mu_1 - \lambda_1 - \lambda_2)^2} \right) \\ &= \lambda_1 \mu_1 \left( \frac{te^{-(\lambda_1 + \lambda_2)t}}{\mu_1 - \lambda_1 - \lambda_2} + \frac{e^{-\mu_1 t} - e^{-(\lambda_1 + \lambda_2)t}}{(\mu_1 - \lambda_1 - \lambda_2)^2} \right). \end{aligned}$$

Once again the same derivation can be done for node five where  $\lambda_2$  and  $\mu_2$  replace  $\lambda_1$  and  $\mu_1$  respectively. Applying this substitution gives

$$\begin{aligned} P_5(t) &= P \{E_{21} + R_{21} < t, E_{11} + R_{21} > t, E_{21} + E_{22} + R_{21} > t\} \\ &= \lambda_2 \mu_2 \left( \frac{te^{-(\lambda_1 + \lambda_2)t}}{\mu_2 - \lambda_1 - \lambda_2} + \frac{e^{-\mu_2 t} - e^{-(\lambda_1 + \lambda_2)t}}{(\mu_2 - \lambda_1 - \lambda_2)^2} \right). \end{aligned}$$

### Tier Three

Tier three is comprised of nodes that denote event streams consisting of three events. Node six represents the first terminating node in the graph and thus its nodal proba-

bility should approach a finite number as  $t$  goes to infinity. It depicts the case where component one has failed and been repaired, but then fails again prior to component two failing. The probability of being at node six at any time  $t$  is

$$\begin{aligned}
P_6(t) &= P\{E_{11} + E_{12} + R_{11} < t, E_{11} + E_{12} < E_{21} | T \leq t - R_{11}\} \\
&= \int_0^t \int_0^{t-r} P\{E_{21} > x\} f_{E_{11}+E_{12}}(x) dx f_{R_{11}}(r) dr \\
&= \lambda_1^2 \mu_1 \int_0^t \int_0^{t-r} x e^{-(\lambda_1+\lambda_2)x} dx e^{-\mu_1 r} dr \\
&= \frac{\lambda_1^2 \mu_1}{(\lambda_1 + \lambda_2)^2} \int_0^t \left( e^{-\mu_1 r} - ((\lambda_1 + \lambda_2)t + 1) e^{-(\lambda_1+\lambda_2)t} e^{(\lambda_1+\lambda_2-\mu_1)r} \right. \\
&\quad \left. + (\lambda_1 + \lambda_2) e^{-(\lambda_1+\lambda_2)t} r e^{-(\mu_1-\lambda_1-\lambda_2)r} \right) dr \\
&= \frac{\lambda_1^2 \mu_1}{(\lambda_1 + \lambda_2)^2} \left( \frac{1 - e^{-\mu_1 t}}{\mu_1} + \frac{(\lambda_1 + \lambda_2)t + 1}{\lambda_1 + \lambda_2 - \mu_1} (e^{-(\lambda_1+\lambda_2)t} - e^{-\mu_1 t}) \right. \\
&\quad \left. + \frac{\lambda_1 + \lambda_2}{(\mu_1 - \lambda_1 - \lambda_2)^2} (e^{-(\lambda_1+\lambda_2)t} - e^{-\mu_1 t} ((\mu_1 - \lambda_1 - \lambda_2)t + 1)) \right).
\end{aligned}$$

The node that is similar to this on the other side of the graph is node nine and its probability expression is

$$\begin{aligned}
P_9(t) &= P\{E_{21} + E_{22} + R_{21} < t, E_{21} + E_{22} < E_{11} | T \leq t - R_{21}\} \\
&= \frac{\lambda_2^2 \mu_2}{(\lambda_1 + \lambda_2)^2} \left( \frac{1 - e^{-\mu_2 t}}{\mu_2} + \frac{(\lambda_1 + \lambda_2)t + 1}{\lambda_1 + \lambda_2 - \mu_2} (e^{-(\lambda_1+\lambda_2)t} - e^{-\mu_2 t}) \right. \\
&\quad \left. + \frac{\lambda_1 + \lambda_2}{(\mu_2 - \lambda_1 - \lambda_2)^2} (e^{-(\lambda_1+\lambda_2)t} - e^{-\mu_2 t} ((\mu_2 - \lambda_1 - \lambda_2)t + 1)) \right).
\end{aligned}$$

If interested in the long-run behavior at these nodes then the limit of their probability expressions is taken as  $t$  goes to infinity,

$$\begin{aligned}
\lim_{t \rightarrow \infty} P_6(t) &= \frac{\lambda_1^2}{(\lambda_1 + \lambda_2)^2} \text{ and} \\
\lim_{t \rightarrow \infty} P_9(t) &= \frac{\lambda_2^2}{(\lambda_1 + \lambda_2)^2}.
\end{aligned}$$

This is exactly what is expected to happen in the long-term analysis of a terminating node since it represents an absorbing state.

The other nodes on this tier are nodes seven and eight. The nodal probability for node seven, given that  $T \leq t - R_{11}$ , is

$$\begin{aligned}
P_7(t) &= P \{E_{21} + R_{11} < t, E_{21} + R_{11} + R_{21} > t, E_{11} < E_{21}, E_{21} < E_{11} + E_{12}\} \\
&= \int_0^t \int_0^{t-r} \int_0^y P \{R_{21} > t - y - r\} P \{E_{12} > y - x\} f_{E_{11}}(x) dx f_{E_{21}}(y) dy f_{R_{11}}(r) dr \\
&= \lambda_1 \lambda_2 \mu_1 e^{-\mu_2 t} \int_0^t \int_0^{t-r} \int_0^y e^{-(\lambda_1 + \lambda_2 - \mu_2)y} dx dy e^{(\mu_2 - \mu_1)r} dr \\
&= \lambda_1 \lambda_2 \mu_1 e^{-\mu_2 t} \int_0^t \int_0^{t-r} y e^{-(\lambda_1 + \lambda_2 - \mu_2)y} dx dy e^{(\mu_2 - \mu_1)r} dr \\
&= \frac{\lambda_1 \lambda_2 \mu_1 e^{-\mu_2 t}}{(\lambda_1 + \lambda_2 - \mu_2)^2} \int_0^t \left( e^{(\mu_2 - \mu_1)r} - ((\lambda_1 + \lambda_2 - \mu_2)t + 1) e^{-(\lambda_1 + \lambda_2 - \mu_2)t} e^{(\lambda_1 + \lambda_2 - \mu_1)r} \right. \\
&\quad \left. + (\lambda_1 + \lambda_2 - \mu_2) e^{-(\lambda_1 + \lambda_2 - \mu_2)t} r e^{(\lambda_1 + \lambda_2 - \mu_1)r} \right) dr \\
&= \frac{\lambda_1 \lambda_2 \mu_1}{(\lambda_1 + \lambda_2 - \mu_2)^2} \left( \frac{e^{-\mu_1 t} - e^{-\mu_2 t}}{\mu_2 - \mu_1} + \frac{(\lambda_1 + \lambda_2 - \mu_2)t + 1}{\lambda_1 + \lambda_2 - \mu_1} (e^{-(\lambda_1 + \lambda_2)t} - e^{-\mu_1 t}) \right. \\
&\quad \left. + \frac{\lambda_1 + \lambda_2 - \mu_2}{(\mu_1 - \lambda_1 - \lambda_2)^2} (e^{-(\lambda_1 + \lambda_2)t} - e^{-\mu_1 t} ((\mu_1 - \lambda_1 - \lambda_2)t + 1)) \right).
\end{aligned}$$

The nodal probability for node eight is the same as that of seven's where  $\lambda_2$  and  $\mu_2$  replace  $\lambda_1$  and  $\mu_1$  respectively. Given that  $T \leq t - R_{11}$

$$\begin{aligned}
P_8(t) &= P \{E_{11} + R_{21} < t, E_{11} + R_{11} + R_{21} > t, E_{21} < E_{11}, E_{11} < E_{21} + E_{22}\} \\
&= \frac{\lambda_1 \lambda_2 \mu_2}{(\lambda_1 + \lambda_2 - \mu_1)^2} \left( \frac{e^{-\mu_2 t} - e^{-\mu_1 t}}{\mu_1 - \mu_2} + \frac{(\lambda_1 + \lambda_2 - \mu_1)t + 1}{\lambda_1 + \lambda_2 - \mu_2} (e^{-(\lambda_1 + \lambda_2)t} - e^{-\mu_2 t}) \right. \\
&\quad \left. + \frac{\lambda_1 + \lambda_2 - \mu_1}{(\mu_2 - \lambda_1 - \lambda_2)^2} (e^{-(\lambda_1 + \lambda_2)t} - e^{-\mu_2 t} ((\mu_2 - \lambda_1 - \lambda_2)t + 1)) \right).
\end{aligned}$$

#### **Tier Four**

Node ten on tier four represents the event stream where both component one and two have failed and been repaired by time  $t$ . Since there are two paths coming into

it, its probability expression is the sum of two separate expressions. The probability of being at this node for any time  $t$ ,  $P_{10}(t)$ , given that  $T \leq t - (R_{11} + R_{21})$ , is

$$\begin{aligned}
&= P \{E_{11} + E_{12} + R_{11} + R_{21} > t, E_{21} + E_{22} + R_{11} + R_{21} > t, E_{21} + R_{11} + R_{21} < t, E_{11} < E_{21}\} \\
&+ P \{E_{11} + E_{12} + R_{11} + R_{21} > t, E_{21} + E_{22} + R_{11} + R_{21} > t, E_{11} + R_{11} + R_{21} < t, E_{21} < E_{11}\} \\
&= \int_0^t \int_0^{t-r} \int_0^y P \{E_{12} > t - x - r\} P \{E_{22} > t - y - r\} f_{E_{11}}(x) dx f_{E_{21}}(y) dy f_{R_{11}+R_{21}}(r) dr \\
&+ \int_0^t \int_0^{t-r} \int_0^y P \{E_{12} > t - x - r\} P \{E_{22} > t - y - r\} f_{E_{21}}(x) dx f_{E_{11}}(y) dy f_{R_{11}+R_{21}}(r) dr \\
&= \frac{\lambda_1 \lambda_2 \mu_1 \mu_2 e^{-(\lambda_1 + \lambda_2)t}}{\mu_1 - \mu_2} \int_0^t \int_0^{t-r} \int_0^y e^{(\lambda_1 + \lambda_2 - \mu_2)r} - e^{(\lambda_1 + \lambda_2 - \mu_1)y} dy dr \\
&\quad + \frac{\lambda_1 \lambda_2 \mu_1 \mu_2 e^{-(\lambda_1 + \lambda_2)t}}{\mu_1 - \mu_2} \int_0^t \int_0^{t-r} \int_0^y e^{(\lambda_1 + \lambda_2 - \mu_2)r} - e^{(\lambda_1 + \lambda_2 - \mu_1)y} dy dr \\
&= \frac{2\lambda_1 \lambda_2 \mu_1 \mu_2 e^{-(\lambda_1 + \lambda_2)t}}{\mu_1 - \mu_2} \int_0^t \int_0^{t-r} \int_0^y e^{(\lambda_1 + \lambda_2 - \mu_2)r} - e^{(\lambda_1 + \lambda_2 - \mu_1)y} dy dr \\
&= \frac{2\lambda_1 \lambda_2 \mu_1 \mu_2 e^{-(\lambda_1 + \lambda_2)t}}{\mu_1 - \mu_2} \int_0^t \int_0^{t-r} y (e^{(\lambda_1 + \lambda_2 - \mu_2)r} - e^{(\lambda_1 + \lambda_2 - \mu_1)y}) dr \\
&= \frac{\lambda_1 \lambda_2 \mu_1 \mu_2 e^{-(\lambda_1 + \lambda_2)t}}{\mu_1 - \mu_2} \int_0^t (t - r)^2 (e^{(\lambda_1 + \lambda_2 - \mu_2)r} - e^{(\lambda_1 + \lambda_2 - \mu_1)r}) dr \\
&= \frac{\lambda_1 \lambda_2 \mu_1 \mu_2}{\mu_1 - \mu_2} \left( \frac{t^2 e^{-\mu_2 t} - t^2 e^{-(\lambda_1 + \lambda_2)t}}{\lambda_1 + \lambda_2 - \mu_2} + \frac{t^2 e^{-(\lambda_1 + \lambda_2)t} - t^2 e^{-\mu_1 t}}{\lambda_1 + \lambda_2 - \mu_1} \right. \\
&\quad + \frac{2te^{-\mu_2 t}((\mu_2 - \lambda_1 - \lambda_2)t + 1) - 2te^{-(\lambda_1 + \lambda_2)t}}{(\mu_2 - \lambda_1 - \lambda_2)^2} \\
&\quad + \frac{2te^{-(\lambda_1 + \lambda_2)t} - 2te^{-\mu_1 t}((\mu_1 - \lambda_1 - \lambda_2)t + 1)}{(\mu_1 - \lambda_1 - \lambda_2)^2} \\
&\quad + \frac{2e^{-(\lambda_1 + \lambda_2)t} - e^{-\mu_2 t}((\mu_2 - \lambda_1 - \lambda_2)^2 t^2 + 2t(\mu_2 - \lambda_1 - \lambda_2) + 2)}{(\mu_2 - \lambda_1 - \lambda_2)^3} \\
&\quad \left. + \frac{e^{-\mu_1 t}((\mu_1 - \lambda_1 - \lambda_2)^2 t^2 + 2t(\mu_1 - \lambda_1 - \lambda_2) + 2) - 2e^{-(\lambda_1 + \lambda_2)t}}{(\mu_1 - \lambda_1 - \lambda_2)^3} \right).
\end{aligned}$$

### **Tier Five**

The last tier is comprised of nodes eleven and twelve, both of which are terminating nodes. Node eleven represents the event stream where component one has failed and been repaired, component two has failed and been repaired, followed by component

one failing for its final time by time  $t$ . This probability is

$$\begin{aligned}
P_{11}(t) &= P \{E_{11} + E_{12} < E_{21} + E_{22}, E_{21} < E_{11} + E_{12} | T < t - (R_{11} + R_{21})\} \\
&= \int_0^t \int_0^{t-r} \int_0^y P \{E_{22} > y - x\} f_{E_{21}}(x) dx f_{E_{11}+E_{12}}(y) dy f_{R_{11}+R_{21}}(r) dr \\
&= \frac{\lambda_1^2 \lambda_2 \mu_1 \mu_2}{\mu_1 - \mu_2} \int_0^t \int_0^{t-r} \int_0^y e^{-\lambda_2 y} e^{\lambda_2 x} e^{-\lambda_2 x} dx y e^{-\lambda_1 y} dy (e^{-\mu_2 r} - e^{-\mu_1 r}) dr \\
&= \frac{\lambda_1^2 \lambda_2 \mu_1 \mu_2}{\mu_1 - \mu_2} \int_0^t \int_0^{t-r} (y^2 e^{-(\lambda_1 + \lambda_2) y}) dy (e^{-\mu_2 r} - e^{-\mu_1 r}) dr \\
&= \frac{\lambda_1^2 \lambda_2 \mu_1 \mu_2}{(\mu_1 - \mu_2)(\lambda_1 + \lambda_2)^3} \int_0^t \left( 2 - e^{-(\lambda_1 + \lambda_2)t} e^{(\lambda_1 + \lambda_2)r} \left( (\lambda_1 + \lambda_2)^2 (t - r)^2 \right. \right. \\
&\quad \left. \left. + 2(t - r)(\lambda_1 + \lambda_2) + 2 \right) \right) (e^{-\mu_2 r} - e^{-\mu_1 r}) dr \\
&= \frac{\lambda_1^2 \lambda_2 \mu_1 \mu_2}{(\mu_1 - \mu_2)(\lambda_1 + \lambda_2)^3} \int_0^t \left( 2 - e^{-(\lambda_1 + \lambda_2)t} e^{(\lambda_1 + \lambda_2)r} \left( (\lambda_1 + \lambda_2)^2 t^2 + 2t(\lambda_1 + \lambda_2) + 2 \right) \right. \\
&\quad \left. + 2e^{-(\lambda_1 + \lambda_2)t} \left( t(\lambda_1 + \lambda_2)^2 + \lambda_1 + \lambda_2 \right) r e^{(\lambda_1 + \lambda_2)r} - (\lambda_1 + \lambda_2)^2 e^{-(\lambda_1 + \lambda_2)t} r^2 e^{(\lambda_1 + \lambda_2)r} \right) \\
&\quad (e^{-\mu_2 r} - e^{-\mu_1 r}) dr \\
&= \frac{\lambda_1^2 \lambda_2 \mu_1 \mu_2}{(\mu_1 - \mu_2)(\lambda_1 + \lambda_2)^3} \left( \int_0^t 2 (e^{-\mu_2 r} - e^{-\mu_1 r}) dr \right. \tag{20} \\
&\quad \left. - e^{-(\lambda_1 + \lambda_2)t} \left( (\lambda_1 + \lambda_2)^2 t^2 + 2t(\lambda_1 + \lambda_2) + 2 \right) \int_0^t e^{(\lambda_1 + \lambda_2)r} (e^{-\mu_2 r} - e^{-\mu_1 r}) dr \right. \tag{21} \\
&\quad \left. + 2e^{-(\lambda_1 + \lambda_2)t} \left( t(\lambda_1 + \lambda_2)^2 + \lambda_1 + \lambda_2 \right) \int_0^t r e^{(\lambda_1 + \lambda_2)r} (e^{-\mu_2 r} - e^{-\mu_1 r}) dr \right. \tag{22} \\
&\quad \left. - (\lambda_1 + \lambda_2)^2 e^{-(\lambda_1 + \lambda_2)t} \int_0^t r^2 e^{(\lambda_1 + \lambda_2)r} (e^{-\mu_2 r} - e^{-\mu_1 r}) dr \right). \tag{23}
\end{aligned}$$

For clarity the above expressions are evaluated separately, this analysis is conducted without including the constant expression that is multiplied times all of the integral expressions. First the integral expression shown in (20) is

$$\int_0^t 2e^{-\mu_2 r} - 2e^{-\mu_1 r} dr = \frac{2 - 2e^{-\mu_2 t}}{\mu_2} + \frac{2e^{-\mu_1 t} - 2}{\mu_1}. \tag{24}$$

Next, Equation (21)

$$\begin{aligned}
&= -e^{-(\lambda_1+\lambda_2)t} \left( (\lambda_1 + \lambda_2)^2 t^2 + 2t(\lambda_1 + \lambda_2) + 2 \right) \int_0^t e^{(\lambda_1+\lambda_2-\mu_1)r} - e^{(\lambda_1+\lambda_2-\mu_2)r} dr \\
&= \left( (\lambda_1 + \lambda_2)^2 t^2 + 2t(\lambda_1 + \lambda_2) + 2 \right) \left( \frac{e^{-\mu_1 t} - e^{-(\lambda_1+\lambda_2)t}}{\lambda_1 + \lambda_2 - \mu_1} + \frac{e^{-(\lambda_1+\lambda_2)t} - e^{-\mu_2 t}}{\lambda_1 + \lambda_2 - \mu_2} \right).
\end{aligned} \tag{25}$$

The expression in (22)

$$\begin{aligned}
&= 2e^{-(\lambda_1+\lambda_2)t} \left( t(\lambda_1 + \lambda_2)^2 + \lambda_1 + \lambda_2 \right) \int_0^t r e^{-(\mu_2-\lambda_1-\lambda_2)r} - r e^{-(\mu_1-\lambda_1-\lambda_2)r} dr \\
&= \left( 2t(\lambda_1 + \lambda_2)^2 + 2\lambda_1 + 2\lambda_2 \right) \left( \frac{e^{-(\lambda_1+\lambda_2)t} - e^{-\mu_2 t} \left( (\mu_2 - \lambda_1 - \lambda_2)t + 1 \right)}{(\mu_2 - \lambda_1 - \lambda_2)^2} \right. \\
&\quad \left. + \frac{e^{-\mu_1 t} \left( (\mu_1 - \lambda_1 - \lambda_2)t + 1 \right) - e^{-(\lambda_1+\lambda_2)t}}{(\mu_1 - \lambda_1 - \lambda_2)^2} \right).
\end{aligned} \tag{26}$$

Finally, the expression shown in Equation (23)

$$\begin{aligned}
&= (\lambda_1 + \lambda_2)^2 e^{-(\lambda_1+\lambda_2)t} \int_0^t r^2 e^{-(\mu_1-\lambda_1-\lambda_2)r} - r^2 e^{-(\mu_2-\lambda_1-\lambda_2)r} dr \\
&= (\lambda_1 + \lambda_2)^2 \left( \frac{2e^{-(\lambda_1+\lambda_2)t} - e^{-\mu_1 t} \left( (\mu_1 - \lambda_1 - \lambda_2)^2 t^2 + 2t(\mu_1 - \lambda_1 - \lambda_2) + 2 \right)}{(\mu_1 - \lambda_1 - \lambda_2)^3} \right. \\
&\quad \left. \frac{e^{-\mu_2 t} \left( (\mu_2 - \lambda_1 - \lambda_2)^2 t^2 + 2t(\mu_2 - \lambda_1 - \lambda_2) + 2 \right) - 2e^{-(\lambda_1+\lambda_2)t}}{(\mu_2 - \lambda_1 - \lambda_2)^3} \right).
\end{aligned} \tag{27}$$

Thus the total probability of being at node eleven at time  $t$  is equal to the constant shown initially times the sum of the expressions shown in Equations (24), (25), (26), and (27). Or

$$P_{11}(t) = \frac{\lambda_1^2 \lambda_2 \mu_1 \mu_2}{(\mu_1 - \mu_2)(\lambda_1 + \lambda_2)^3} ((24) + (25) + (26) + (27)).$$

As was stated previously the expression for  $P_{12}(t)$  is similar where  $\lambda_2$  replaces  $\lambda_1$ .

$$\begin{aligned}
P_{12}(t) = & \frac{\lambda_1 \lambda_2^2 \mu_1 \mu_2}{(\mu_1 - \mu_2)(\lambda_1 + \lambda_2)^3} \left( \frac{2 - 2e^{-\mu_2 t}}{\mu_2} + \frac{2e^{-\mu_1 t} - 2}{\mu_1} \right. \\
& + \left( (\lambda_1 + \lambda_2)^2 t^2 + 2t(\lambda_1 + \lambda_2) + 2 \right) \left( \frac{e^{-\mu_1 t} - e^{-(\lambda_1 + \lambda_2)t}}{\lambda_1 + \lambda_2 - \mu_1} + \frac{e^{-(\lambda_1 + \lambda_2)t} - e^{-\mu_2 t}}{\lambda_1 + \lambda_2 - \mu_2} \right) \\
& + \left( 2t(\lambda_1 + \lambda_2)^2 + 2\lambda_1 + 2\lambda_2 \right) \left( \frac{e^{-(\lambda_1 + \lambda_2)t} - e^{-\mu_2 t} \left( (\mu_2 - \lambda_1 - \lambda_2)t + 1 \right)}{(\mu_2 - \lambda_1 - \lambda_2)^2} \right. \\
& \left. + \frac{e^{-\mu_1 t} \left( (\mu_1 - \lambda_1 - \lambda_2)t + 1 \right) - e^{-(\lambda_1 + \lambda_2)t}}{(\mu_1 - \lambda_1 - \lambda_2)^2} \right) \\
& + (\lambda_1 + \lambda_2)^2 \left( \frac{2e^{-(\lambda_1 + \lambda_2)t} - e^{-\mu_1 t} \left( (\mu_1 - \lambda_1 - \lambda_2)^2 t^2 + 2t(\mu_1 - \lambda_1 - \lambda_2) + 2 \right)}{(\mu_1 - \lambda_1 - \lambda_2)^3} \right. \\
& \left. \left. \frac{e^{-\mu_2 t} \left( (\mu_2 - \lambda_1 - \lambda_2)^2 t^2 + 2t(\mu_2 - \lambda_1 - \lambda_2) + 2 \right) - 2e^{-(\lambda_1 + \lambda_2)t}}{(\mu_2 - \lambda_1 - \lambda_2)^3} \right) \right).
\end{aligned}$$

To be sure that the above expressions for the terminating nodes are correct, one can look at the limiting behavior of these nodes. The limit of the nodal probabilities for the terminating nodes is collectively exhaustive. For node eleven this limit is

$$\begin{aligned}
\lim_{t \rightarrow \infty} P_{11}(t) &= \frac{\lambda_1^2 \lambda_2 \mu_1 \mu_2}{(\mu_1 - \mu_2)(\lambda_1 + \lambda_2)^3} \left( \frac{2}{\mu_2} - \frac{2}{\mu_1} \right) \\
&= \frac{2\lambda_1^2 \lambda_2}{(\lambda_1 + \lambda_2)^3}.
\end{aligned}$$

Similarly for node twelve

$$\lim_{t \rightarrow \infty} P_{12}(t) = \frac{2\lambda_1 \lambda_2^2}{(\lambda_1 + \lambda_2)^3}.$$

The sum of the limiting probabilities for nodes eleven and twelve yields

$$\begin{aligned}
\lim_{t \rightarrow \infty} (P_{11}(t) + P_{12}(t)) &= \frac{2\lambda_1^2 \lambda_2 + 2\lambda_1 \lambda_2^2}{(\lambda_1 + \lambda_2)^3} \\
&= \frac{2\lambda_1 \lambda_2}{(\lambda_1 + \lambda_2)^2}.
\end{aligned}$$

Thus, the sum of all the limiting probabilities for the terminating nodes is

$$\begin{aligned}\lim_{t \rightarrow \infty} (P_6(t) + P_9(t) + P_{11}(t) + P_{12}(t)) &= \frac{\lambda_1^2 + \lambda_2^2 + 2\lambda_1\lambda_2}{(\lambda_1 + \lambda_2)^2} \\ &= 1.\end{aligned}$$

## Bibliography

1. Adamyan, A. and He, D. (2002). Failure and safety assessment of systems using petri nets. *In Proceedings of the IEEE International Conference on Robotics and Automation*, **2**, 1919–1924.
2. Amari, S. V. and Akers, J. B. (2004). Reliability analysis of large fault trees using the vesely failure rate. *In Proceedings of the Annual Reliability and Maintainability Symposium*, 391–396.
3. Barlow, E. B. and Proschan, F. (1975). *Statistical Theory of Reliability and Life Testing: Probability Models*. Holt, Reinhart & Wilson.
4. Barlow, R. E. and Proschan, F. (1975). Importance of system components and fault tree events. *Stochastic Processes and their Applications*, **3**, 153–173.
5. Barlow, R. E. and Proschan, F. (1996). *Mathematical Theory of Reliability*. Society for Industrial & Applied Mathematics.
6. Biswas, A., Sarkar, J., and Sarkar, S. (2003). Availability of a periodically inspected system, maintained under an imperfect-repair policy. *IEEE Transactions on Reliability*, **52**, 311–318.
7. Bolch, G., Greiner, S., de Meer, H., Trivedi, K. S., Greiner, S., de Meer, H., and Trivedi, K. S. (1998). *Queueing Networks and Markov Chains : Modeling and Performance Evaluation With Computer Science Applications*. Wiley-Interscience.
8. Cao, Y., Sun, H., Trivedi, K. S., and Han, J. J. (2002). System availability with non-exponentially distributed outages. *IEEE Transactions on Reliability*, **51**, 193–198.
9. Chan, J.-K. and Shaw, L. (1993). Modeling repairable systems with failure rates that depend on age & maintenance. *IEEE Transactions on Reliability*, **42**, 566–571.
10. Chaudhuri, G., Hu, K., and Afshar, N. (2001). A new approach to system reliability. *IEEE Transactions on Reliability*, **50**, 75–84.
11. Demichela, M., Piccinini, N., Ciarambino, I., and Contini, S. (2003). On the numerical solution of fault trees. *Reliability Engineering and System Safety*, **82**, 141–147.
12. Denhard, D. R. (2001). *Theater-Level Stochastic Air-To-Air Engagement Modeling Via Event Occurrence Networks Using Piecewise Polynomial Approximation*. Ph.D. Thesis, Air Force Institute of Technology, Wright-Patterson Air Force Base, Ohio.
13. Dhillon, B. and Rayapati, S. (1988). Common-cause failures in repairable systems. *In Proceedings of the Reliability and Maintainability Symposium*, 283–289.

14. Doetsch, G. (1971). *Guide to the Applications of the Laplace and Z Transforms*. Van Nostrum & Reinhold.
15. Doyon, L. R., Cherry, E. M., Renfroe, H. L., and Wristen, H. A. (1982). AFARS — An algorithm for analyzing the reliability of systems. *Computers & Industrial Engineering*, **6**, 237–253.
16. Dutuit, Y. and Rauzy, A. (2005). Approximate estimation of system reliability via fault trees. *Reliability Engineering and System Safety*, **87**, 163–172.
17. Gough, W. S., Riley, J., and Koren, J. M. (1990). New approach to the analysis of reliability block diagrams. *In Proceedings of the Annual Reliability and Maintainability Symposium*, 456–464.
18. Goyal, A. and Tantawi, A. (1988). A measure of guaranteed availability and its numerical evaluation. *IEEE Transactions on Computers*, **37**, 25–32.
19. Haimes, Y. Y. (2004). *Risk Modeling, Assessment, and Management*. John Wiley & Sons.
20. Hassett, T., Dietrich, D., and Szidarovszky, F. (1995). Time-varying failure rates in the availability and reliability analysis of repairable systems. *IEEE Transactions on Reliability*, **44**, 155–160.
21. Kim, M. C. and Seong, P. H. (2002). Reliability graph with general gates: An intuitive and practical method for system reliability analysis. *Reliability Engineering and System Safety*, **78**, 239–246.
22. Kulkarni, V. G. (1996). *Modeling and Analysis of Stochastic Systems*. Chapman & Hall.
23. Leemis, L. (1995). *Reliability: Probabilistic Models and Statistical Methods*. Prentice Hall.
24. Lie, C. H., Hwang, C. L., and Tillman, F. A. (1977). Availability of maintained systems: a state-of-the-art survey. *AIIE Transactions*, **9**, 247–259.
25. Martz, H. F. and Waller, R. A. (1982). *Bayesian Reliability Analysis*. John Wiley & Sons.
26. Meshkat, L., Dugan, J. B., and Andrews, J. D. (2002). Dependability analysis of systems with on-demand and active failure modes, using dynamic fault trees. *IEEE Transactions on Reliability*, **51**, 240–251.
27. Mettas, A. (2000). Reliability allocation and optimization for complex systems. *In Proceedings of the Annual Reliability and Maintainability Symposium*, 216–221.
28. Mettas, A. and Zhao, W. (2005). Modeling and analysis of repairable systems with general repair. *In Proceedings of the Annual Reliability and Maintainability Symposium*, 176–182.

29. Muntz, R. R., de Souza e Silva, E., and Goyal, A. (1989). Bounding availability of repairable systems. *IEEE Transactions on Computers*, **38**, 1714–1723.
30. Newton, J. (1996). Comment on: Time-varying failure rates in the availability and reliability analysis of repairable systems. *IEEE Transactions on Reliability*, **45**, 27.
31. Pattipati, K., Li, Y., and Blom (1989). On the instantaneous availability and performability evaluation of fault-tolerant computer systems. *In Proceedings of the IEEE International Conference on Systems, Man, and Cybernetics*, 376–382.
32. Pham-Gia, T. and Turkkan, N. (1999). System availability in a gamma alternating renewal process. *Naval Research Logistics*, **46**, 822–844.
33. Rausand, M. and Hoyland, A. (2004). *System Reliability Theory*. John Wiley & Sons.
34. Reineke, D. M., Murdock, W. P. J., Pohl, E. A., and Rehmert, I. (1999). Improving availability and cost performance for complex systems with preventive maintenance. *In Proceedings of the Annual Reliability and Maintainability Symposium*, 383–388.
35. Rueda, A. and Pawlak, M. (2004). Pioneers of the reliability theories of the past 50 years. *In Proceedings of the Annual Reliability and Maintainability Symposium*, 102–109.
36. Savage, E. L., Schruben, L. W., and Yücesan, E. (2005). On the generality of event-graph models. *INFORMS Journal on Computing*, **17**, 3–9.
37. Shier, D. R. and Whited, D. E. (1986). Iterative algorithms for generating minimal cutsets in directed graphs. *Networks*, **16**, 133–147.
38. Sinnamon, R. M. and Andrews, J. D. (1996). Fault tree analysis and binary decision diagrams. *In Proceedings of the Annual Reliability and Maintainability Symposium*, 215–222.
39. Tillman, F. A., Kuo, W., Nassar, R. F., and Hwang, C. L. (1983). Numerical evaluation of instantaneous availability. *IEEE Transactions on Reliability*, **32**, 119–123.
40. Trivedi, K. S. (2001). *Probability and Statistics with Reliability, Queueing, and Computer Science Applications, 2nd Edition*. Wiley-Interscience.
41. Villemeur, A. (1991). *Reliability, Availability, Maintainability and Safety Assessment, Methods and Techniques*. John Wiley & Sons.
42. Villemeur, A. (1992). *Reliability, Availability, Maintainability and Safety Assessment*. John Wiley & Sons.
43. Wang, Y., Teague, T., West, H., and Mannan, S. (2002). A new algorithm for computer-aided fault tree synthesis. *Journal of Loss Prevention in the Process Industries*, **15**, 265–277.

44. Xu, H. and Dugan, J. (2004). Combining dynamic fault trees and event trees for probabilistic risk assessment. *In Proceedings of the Annual Reliability and Maintainability Symposium*, 214–219.
45. Zhang, T. and Horigome, M. (2001). Availability and reliability of system with dependent components and time-varying failure and repair rates. *IEEE Transactions on Reliability*, **50**, 151–158.

## *Glossary*

<b>availability graph</b>	graphical structure used to represent repairable systems, 51
<b>convolution</b>	mathematical operator which takes two functions and produces a third function that represents the amount of overlap between the two functions, 17
<b>CTMC</b>	a stochastic process that possesses the Markov property and takes on values from amongst the elements of a discrete set called the state space, 5
<b>cut vector</b>	a vector such that the system does not operate under the state it describes, 27
<b>EON</b>	probabilistic network that represents the superposition of several terminating counting processes, 9
<b>intermediate node</b>	the occurrence of an event that does not prohibit other events from occurring, 10
<b>minimal cut vector</b>	cut vector such that any component that is currently off turning on will cause the system to become functional, 27
<b>minimal path vector</b>	path vector such that any component that is currently on turning off will cause the system to fail, 26
<b>parallel system</b>	a system that operates when $k$ or more of its components are functioning, 24
<b>path vector</b>	a vector such that the system operates under the state it describes, 26
<b>RBD</b>	binary diagram that depicts the functional relationship between components in an operational system, 6

<b>reliability of an item</b>	the probability that it will be adequately performing its specified purpose for a specified period of time under specified environmental conditions, 2
<b>series system</b>	system that only functions when all of its components function, 24
<b>system availability</b>	the ability of a system to be in a state to perform its required function under given conditions at a given instance in time, 3
<b>terminating node/concluding event</b>	the occurrence of an event that prohibits other events from occurring, 10
<b>tier</b>	level in graphical model (EON) or number of events that have occurred, 14

# REPORT DOCUMENTATION PAGE

Form Approved  
OMB No. 0704-0188

The public reporting burden for this collection of information is estimated to average 1 hour per response, including the time for reviewing instructions, searching existing data sources, gathering and maintaining the data needed, and completing and reviewing the collection of information. Send comments regarding this burden estimate or any other aspect of this collection of information, including suggestions for reducing this burden to Department of Defense, Washington Headquarters Services, Directorate for Information Operations and Reports (0704-0188), 1215 Jefferson Davis Highway, Suite 1204, Arlington, VA 22202-4302. Respondents should be aware that notwithstanding any other provision of law, no person shall be subject to any penalty for failing to comply with a collection of information if it does not display a currently valid OMB control number. PLEASE DO NOT RETURN YOUR FORM TO THE ABOVE ADDRESS.

<b>1. REPORT DATE</b> (DD-MM-YYYY) 21-03-2006		<b>2. REPORT TYPE</b> Master's Thesis		<b>3. DATES COVERED</b> (From — To) Sept 2004 — Mar 2006	
<b>4. TITLE AND SUBTITLE</b>  RELIABILITY OF SYSTEMS USING EVENT OCCURRENCE NETWORKS				<b>5a. CONTRACT NUMBER</b>	
				<b>5b. GRANT NUMBER</b>	
				<b>5c. PROGRAM ELEMENT NUMBER</b>	
<b>6. AUTHOR(S)</b>  Steeger, Gregory M., Capt, USAF				<b>5d. PROJECT NUMBER</b>	
				<b>5e. TASK NUMBER</b>	
				<b>5f. WORK UNIT NUMBER</b>	
<b>7. PERFORMING ORGANIZATION NAME(S) AND ADDRESS(ES)</b> Air Force Institute of Technology Graduate School of Engineering and Management (AFIT/EN) 2950 Hobson Way WPAFB OH 45433-7765				<b>8. PERFORMING ORGANIZATION REPORT NUMBER</b>  AFIT/GOR/ENS/06-17	
<b>9. SPONSORING / MONITORING AGENCY NAME(S) AND ADDRESS(ES)</b>				<b>10. SPONSOR/MONITOR'S ACRONYM(S)</b>	
				<b>11. SPONSOR/MONITOR'S REPORT NUMBER(S)</b>	
<b>12. DISTRIBUTION / AVAILABILITY STATEMENT</b>  Approval for public release; distribution is unlimited.					
<b>13. SUPPLEMENTARY NOTES</b>					
<b>14. ABSTRACT</b>  The study of a system's reliability has played a crucial role in business and industry since the dawn of modern technology. Current graphical models utilized in reliability theory are limited in that no one model or technique allows for a thorough analysis of system reliability. This research introduces a new graphical model and methodology to be used in the field of reliability that addresses this concern. Event Occurrence Networks (EONs) and their solution methodologies provide an all-inclusive graphical model that allows for the manipulation of several important reliability measures. An EON is a probabilistic network that represents the superposition of several terminating counting processes and is an efficient tool in both non-repairable and repairable systems. Current methodologies are also restricted in the distributions that characterize component life and repair times. This concern is alleviated via EONs coupled with piecewise polynomial approximation.					
<b>15. SUBJECT TERMS</b>  event occurrence networks, reliability, availability					
<b>16. SECURITY CLASSIFICATION OF:</b>			<b>17. LIMITATION OF ABSTRACT</b>	<b>18. NUMBER OF PAGES</b>	<b>19a. NAME OF RESPONSIBLE PERSON</b>
<b>a. REPORT</b>	<b>b. ABSTRACT</b>	<b>c. THIS PAGE</b>			Lt Col David Denhard
U	U	U	UU	145	<b>19b. TELEPHONE NUMBER</b> (include area code) (937) 255-3636, ext 4624