

Air Force Institute of Technology

AFIT Scholar

Theses and Dissertations

Student Graduate Works

3-2006

Understanding Innovation Adoption in the Air Force

Morgan J. Evans

Follow this and additional works at: <https://scholar.afit.edu/etd>



Part of the [Industrial Technology Commons](#), and the [Operations and Supply Chain Management Commons](#)

Recommended Citation

Evans, Morgan J., "Understanding Innovation Adoption in the Air Force" (2006). *Theses and Dissertations*. 3422.

<https://scholar.afit.edu/etd/3422>

This Thesis is brought to you for free and open access by the Student Graduate Works at AFIT Scholar. It has been accepted for inclusion in Theses and Dissertations by an authorized administrator of AFIT Scholar. For more information, please contact richard.mansfield@afit.edu.



UNDERSTANDING INNOVATION ADOPTION IN THE AIR FORCE

THESIS

Morgan J. Evans, Captain, USAF

AFIT/GLM/ENS/06-05

**DEPARTMENT OF THE AIR FORCE
AIR UNIVERSITY**

AIR FORCE INSTITUTE OF TECHNOLOGY

Wright-Patterson Air Force Base, Ohio

APPROVED FOR PUBLIC RELEASE; DISTRIBUTION UNLIMITED

The views expressed in this thesis are those of the author and do not reflect the official policy or position of the United States Air Force, Department of Defense, or the United States Government.

AFIT/GLM/ENS/06-05

UNDERSTANDING INNOVATION ADOPTION IN THE AIR FORCE

THESIS

Presented to the Faculty

Department of Operational Sciences

Graduate School of Engineering and Management

Air Force Institute of Technology

Air University

Air Education and Training Command

In Partial Fulfillment of the Requirements for the
Degree of Master of Science in Logistics Management

Morgan J. Evans, BS

Captain, USAF

March 2006

APPROVED FOR PUBLIC RELEASE; DISTRIBUTION UNLIMITED.

AFIT/GLM/ENS/06-05

UNDERSTANDING INNOVATION ADOPTION IN THE AIR FORCE

Morgan J. Evans, BS
Captain, USAF

Approved:

Kirk A. Patterson, Maj, USAF (Chairman)

date

John E. Bell, Maj, USAF (Member)

date

Abstract

Innovation adoption has become a critical issue for organizations in both the public and private sectors. The search for competitive advantage has led to the recognition that innovation is a vital ingredient for an organization's survival and profitability in this information age. The United States Air Force is seeking to adapt to this new information age by transforming its business processes in order to sustain its competitive advantage as the world's most respected air force. Adopting innovations and integrating new or improved technologies, capabilities, concepts, and processes into Air Force planning and acquisition activities, organizations, and operations are goals of Air Force Transformation. Customer Relationship Management is one such innovation that organizations are pursuing to capture competitive advantage. CRM adoption and implementation successes and failures have been well-documented; however, organizational innovation adoption studies and CRM adoption studies in the United States Air Force—within the context of Innovation Diffusion Theory—could not be found. This research attempts to bridge this gap in the literature.

Three innovation characteristics from Diffusion of Innovation Theory and three organizational characteristics, which were found to be significant antecedents to innovation adoption in prior studies, were used to develop innovation adoption hypotheses. These hypotheses were then tested using correlation analysis and multiple linear regression analysis. This research seeks to aid in increasing the understanding of the influences on CRM process innovation adoption within an Air Force organization.

Acknowledgments

I would like to express my sincere appreciation to my thesis advisor, Major Kirk Patterson for his enthusiasm, guidance and patience throughout the course of this thesis effort.

I would also like to thank my reader, Major John Bell, for taking time out of his extremely busy schedule and providing constructive feedback and direction.

Table of Contents

	Page
Abstract.....	iv
Acknowledgments.....	v
Table of Contents.....	vi
List of Figures.....	ix
List of Tables.....	x
I. Introduction.....	1
Overview.....	1
Background.....	1
Problem and Purpose Statement.....	4
Research Question.....	5
Methodology.....	5
Summary.....	6
II. Literature Review.....	7
Introduction.....	7
Customer Relationship Management.....	8
CRM as a Process.....	10
CRM as a Strategy.....	10
CRM as a Philosophy.....	10
CRM as a Capability.....	10
CRM as a Technological Tool.....	11
Innovation.....	11
Innovation Defined.....	13
Types of Innovation.....	13
Product/Process.....	14
Technical/Administrative.....	14
Radical Incremental.....	15
Diffusion of Innovation Theory.....	15
Innovation Decision-Process Model.....	17
Hypothesis Development.....	19
Innovation Characteristics.....	21
Organizational Characteristics.....	23
Proposed Hypotheses.....	26
Proposed Research Model.....	27
Summary.....	28

	Page
III. Methodology	29
Overview	29
Population	29
Instrument Review	30
Survey Design.....	30
Pretest.....	32
Survey Modifications.....	33
Data Collection	33
Measures	34
Innovation Characteristics	36
Organizational Characteristics	40
Data Analysis	47
Correlation Analysis	47
Multiple Regression and Multicollinearity	48
Confounds to Inference	50
Summary	51
IV. Results and Analysis.....	52
Overview	52
Descriptive Statistics.....	52
Correlation Analyses.....	54
Hypothesis 1 Analysis.....	56
Hypothesis 2 Analysis.....	57
Hypothesis 3 Analysis.....	58
Regression Model #1	59
Regression Model #2	61
Summary	63
V. Conclusions and Recommendations	64
Overview	64
Results of the Research	64
Recommendations.....	66
Limitations of the Research	67
Future Research.....	68

Appendix A: AMC Logistics Directorate Organizational Chart	70
Appendix B: Survey Cover Letter	71
Appendix C: Survey Instrument	72
Appendix D: Frequency Tables	76
Appendix E: Histograms.....	80
Appendix F: Detailed Results of Regression Model #1.....	84
Appendix G: Detailed Results of Regression Model #2.....	87
Bibliography	91

List of Figures

	Page
Figure 1. Innovation Decision Process Model.....	18
Figure 2. Proposed Innovation Adoption Research Model.....	27

List of Tables

	Page
Table 1. Demographic Data	35
Table 2. Relative Advantage Item Statistics	36
Table 3. Relative Advantage Reliability Statistics	36
Table 4. Compatibility Item Statistics	37
Table 5. Compatibility Reliability Statistics	37
Table 6. Complexity Item Statistics	38
Table 7. Complexity Reliability Statistics	38
Table 8. Top Management Support Item Statistics	40
Table 9. Top Management Support Reliability Statistics	40
Table 10. Risk-Promoting Climate Item Statistics	41
Table 11. Risk-Promoting Climate Reliability Statistics	41
Table 12. Communication Item Statistics	42
Table 13. Communication Reliability Statistics	42
Table 14. Propensity to Adopt Item Statistics	42
Table 15. Propensity to Adopt Reliability Statistics	45
Table 16. Descriptive Statistics	51
Table 17. Correlation Matrix	54
Table 18. Hypothesis 1 Summary	55
Table 19. Hypothesis 2 Summary	55
Table 20. Regression Model 1 Summary	57
Table 21. Regression Model 2 Summary	58

UNDERSTANDING INNOVATION ADOPTION IN THE AIR FORCE

I. Introduction

Overview

Innovation adoption has become a critical issue for organizations in both the public and private sectors, as many of these organizations conduct business in the global environment and are faced with significant competition. The search for competitive advantage has led to the recognition of innovation as a vital ingredient for an organization's survival and profitability in this information age (Read, 2000). Customer Relationship Management (CRM) is one such innovation that organizations are pursuing to not only capture competitive advantage by attracting new customers but also to satisfy and retain existing customers by developing customer-centric business strategies that offer superior customer service and support. The United States Air Force (USAF) is seeking to adapt to this new information age by transforming its business processes in order to sustain its competitive advantage as the world's most respected air force (USAF, 2003).

The literature has revealed many research efforts dealing with organizational innovation adoption (Damanpour, 1991; Frambach and Schillewaert, 2002; Kimberly and Evanisko, 1981). Additionally, CRM adoption and implementation successes and failures have been well-documented (Davids, 1999; Kale, 2004; Rigby, 2002; Zablah et al., 2004). However, organizational innovation adoption studies and CRM adoption

studies in the USAF—within the context of Innovation Diffusion Theory—could not be found. This research attempts to bridge this gap in the literature.

The focus of this research is to explore the adoption stage of a customer relationship management (CRM) process innovation within an Air Force organization. The study will be accomplished within the framework of Diffusion of Innovation Theory in order to attain a better understanding of innovation characteristics and organizational characteristics that affect the theory's adoption stage. The context of this investigation will be in relation to individual perceptions of these characteristics and the propensity of an organization to adopt a CRM process innovation.

Background

Transformation, in one form or another, has been ongoing in the Air Force since the service became a separate entity in 1947. However, over the past 15 years, a rapidly changing international environment has forced senior leaders to rethink the approaches needed to meet future security challenges and unforeseen threats. In response to these changing conditions, Air Force leadership introduced the 2003 United States Air Force Transformation Flight Plan (AFTFP), which outlined the strategies for the Air Force to transform from a Cold War force to a post-Cold War force (USAF, 2003). Also addressed in the AFTFP is the need to transform an industrial age force to an information age force. Existing Air Force business processes were developed during an industrial age when the United States faced a security environment that was vastly different than today's. Although they have been incrementally reformed and modernized, the underlying philosophy and basic architecture of these business processes have not

changed in decades (USAF, 2003). To sustain the Service's warfighting advantage, the Air Force must ensure that its business processes and operations are efficient, effective, and focused on war-fighting capability.

The Air Force defines the transformation process as:

A process by which the military achieves and maintains advantage through changes in operational concepts, organization, and/or technologies that significantly improve its warfighting capabilities or ability to meet the demands of a changing security environment. (USAF, 2003:ii)

Transformation demands innovative thinking and a process that can identify, examine, and turn new ideas into reality—whether the idea is a new technology, concept, or a novel way to organize. The objective of Air Force innovation is the timely adoption and integration of new or improved technologies, capabilities, concepts, and processes into Air Force planning and acquisition activities, organizations, and operations (USAF, 2003).

With a heightened focus on DoD and Air Force transformation, Headquarters, Air Mobility Command Air Transportation Division (AMC/A43) recognized that transformation must also occur within the air transportation community in order to enhance support to the warfighter. The following AMC/A43 vision statement encapsulates their effort to transform: “World-Class Team Leading the DoD in Transforming Air Transportation for World Wide Expeditionary Mobility Operations” (AMC, 2005). Specifically, AMC/A43 targeted the aerial port community to take an active role in defining and shaping the air transportation transformation. To focus all aerial port activities towards business process improvements, AMC/A43 has developed the Terminal 2010 program.

The Terminal 2010 program seeks to involve both internal and external customers. It provides the corporate strategy to guide process improvement using tools like CRM, Lean, and Six Sigma. The purpose of Terminal 2010 is to transform aerial port operations in order to dramatically increase their responsiveness, operational speed, reach, and effectiveness. From a logistics perspective, that means the right support, at the right place, at the right time (CONOPS, 2006). The objectives of the program are to: (1) make aerial port service predictable, consistent, and reliable in terms of time definite delivery (TDD) to the warfighter, (2) to translate that reliable TDD into reduced customer wait time, and (3) to accomplish this increased consistency and reliability while consuming fewer resources. With such a sharp focus on the customer, AMC/A43 is seeking to adopt a CRM process innovation in order to successfully implement the Terminal 2010 program.

Problem and Purpose Statement

The potential for substantially improved customer relationship management, coupled with the high uncertainty surrounding failed adoption and implementation efforts, call for a critical look at the determinants of, and influences upon, an organization's decision to adopt CRM (Ocker and Mudambi, 2003). Additionally, Diffusion of Innovation Theory has provided a framework to study the innovation adoption process in both the public and private sectors. The purpose of this research is to explore how innovation characteristics and organizational characteristics relate to an Air Force organization's propensity to adopt a CRM process innovation. Using innovation characteristics from Diffusion of Innovation Theory and organizational characteristics

that were found to be significant antecedents to innovation adoption in prior studies, this research seeks to provide insight into future CRM process innovation adoption efforts within the Air Force, particularly during this important period of transformation.

Research Question

In order to arrive at the stated purpose above, the research must be narrowed to a specific question. The focus of this research is to answer the following question: “Do individual perceptions of innovation characteristics (relative advantage, compatibility, and complexity) and organizational characteristics (top management support, risk-promoting climate, and internal communication) relate to an organization’s propensity to adopt a CRM process innovation?”

By developing and testing appropriate innovation adoption hypotheses, this research seeks to aid in increasing the understanding of the influences on process innovation adoption within the Air Force. The hypotheses developed for this research are introduced in Chapter II.

Methodology

A survey was designed to measure and assess individuals’ perceptions of three innovation characteristics (relative advantage, compatibility, and complexity) and three organizational characteristics (top management support, risk-promoting climate, and internal communication) for the adopting organization. The data collected from returned surveys was then applied to and used to test the proposed hypotheses by using correlation analysis and multiple regression analysis. The population, survey instrument, data

collection procedures, and data analysis methodology are presented in detail in Chapter III.

Summary

This chapter introduced the current problem, presented the research question and provided a summary of the methodologies used in this study. Chapter II presents an in-depth review of the existing literature on the subjects of CRM and innovation, and the organization under investigation. Chapter III further describes the research and data collection methodologies used to accomplish the objectives of this study. Chapter IV presents the findings and analysis, while Chapter V provides conclusions and offers areas for further research.

II. Literature Review

Introduction

This chapter provides a thorough review of the literature relevant to both customer relationship management (CRM) and organizational innovation adoption. This review will first give a general overview of CRM. Next, innovation will be discussed by exploring the following areas: innovation, innovation type, and Innovation Diffusion Theory. Following the innovation discussion, the review will provide context for the research model by investigating the determinants of innovation adoption. Previous research will be presented to examine innovation characteristics and organizational characteristics and their subsequent relationships to an organization's propensity to adopt an innovation. Finally, the research hypotheses and research model will be proposed.

This research seeks to further Everett Rogers' Innovation-Decision Process Model by focusing on the initiation stage of the innovation-decision process. The literature has revealed many research efforts dealing with organizational innovation adoption in both the public and private sector. Additionally, CRM adoption and implementation successes and failures have been well-documented. However, organizational innovation adoption studies and CRM adoption studies in the United States Air Force—within the context of Innovation Diffusion Theory—could not be found. The focus of this research will be to bridge this gap in the literature.

Customer Relationship Management

Customer Relationship Management (CRM) is a customer-focused innovation that has attracted business interest and investment over the past 15 years (Missi et al., 2005). It deals with the interface between customers and the company. If a customer calls with a service request, this is a CRM activity. If a company sends a consumer who has recently made a purchase an offer for a related product, this is also a CRM activity. The domain of CRM is the entire set of interactions or contacts with the consumer, whether initiated by the company or by the consumer (Calder, 2005).

The underlying premise of CRM is: If a firm improves upon how it manages relationships with its customers, the result will be evidenced as an increase in firm productivity and customer satisfaction (Ocker and Mudambi, 2003).

CRM means different things to different people (Winer, 2002). Over the past 15 years, much research has been conducted on the topic, and a review of the CRM literature has revealed a plethora of definitions. The following are some examples of the various CRM definitions found in academic and popular literature:

1. “CRM is the infrastructure that enables the delineation of and increase in customer value, and the correct means by which to motivate valuable customers to remain loyal—indeed, to buy again” (Dyche, 2002:4).
2. “CRM is a business strategy built around the concept of being customer-centric” (Harej and Horvat, 2000:108).
3. “CRM aligns business processes with customer strategies to build customer loyalty and increase profits over time” (Rigby et al., 2002:102).

Note the absence of the words technology and software.

4. “CRM is an integration of technologies and business processes used to satisfy the needs of a customer during any given interaction . . . CRM involves acquisition, analysis and use of knowledge about customers in order to sell more goods or services and to do it more efficiently” (Bose, 2002:89).
5. “CRM includes the methodologies, strategies, software, and web-based capabilities that help an enterprise organize and manage customer relationships” (ITtoolbox.com, 2005).
6. “CRM is a tool that firms are using as a strategic approach to systematically target, track, communicate, and transform relevant customer data into actionable information on which strategic decision-making is based” (Missi et al., 2005:1).

Zablah et al. (2004) performed a comprehensive CRM literature review and determined there is a lack of consensus on how CRM should be defined. Their literature review identified over 45 distinct definitions of CRM, and they conducted a detailed analysis to determine common elements and recurring themes. The results of the analysis produced five major perspectives on CRM. The researchers found that CRM has been conceptualized as (1) a process, (2) a strategy, (3) a philosophy, (4) a capability, and (5) a technological tool. A description of each perspective, as presented by Zablah et al. (2004) is provided below.

CRM as a Process.

The process view of CRM accounts for the process aspects of relationship development and maintenance. It is the only perspective that overtly acknowledges that buyer-seller relationships develop over time and must evolve to endure. It is due to this reason that emerging academic research favors and advocates the process perspective of CRM (Day and Van den Bulte, 2002; Reinartz et al., 2003).

CRM as a Strategy.

The strategic view of CRM emphasizes the fact that resources destined for relationship building and maintenance efforts should be allocated based on customers' lifetime value to the firm. More specifically, this view suggests that all customers are not equally valuable and that maximum profitability can only be achieved when available resources are invested in customer relationships that provide a desired level of return.

CRM as a Philosophy.

When defined as a philosophy, CRM refers to the idea that the most effective way to achieve customer loyalty is by proactively seeking to build and maintain long term relationships with customers. Rather than treating recurring transactions between buyers and sellers as isolated events, the philosophical view of CRM stresses that a loyal customer base can only be achieved if interactions are viewed within the context of an ongoing relationship.

CRM as a Capability.

The capability perspective on CRM highlights the fact that firms must invest in developing and acquiring a mix of resources that enables them to modify their behavior towards individual customers or groups of customers on a continual basis. Although the

capability view of CRM has not received widespread support in the literature, it does serve to emphasize that a certain mix of resources are needed to effectively manage customer relationships.

CRM as a Technological Tool.

Although technology is not necessary for effective CRM, it is an important tool that links front and back office functions to provide for the efficient and effective management of interactions across different customer touch-points. In addition, CRM technological tools enable firms to harness the power of database, data mining, and internet technologies to collect and store unprecedented amounts of customer data, build knowledge from that data, and disseminate the resulting knowledge across the organization.

It is important to note that, although the individual definitions researched by Zablah et al. (2004) generally fit into one of the five CRM perspectives, it was not uncommon to find definitions that fit multiple perspectives.

Innovation

Research suggests that innovation in an organization is typically stimulated by a “performance gap” between actual and desired results (Rogers, 1995), and that innovations are adopted with the intent of increasing organizational performance (Damanpour, 1990, 1992). A performance gap may be discovered in comparison to competitors’ practices, missed opportunities in the marketplace, or unmet customer expectations.

Organizational innovation has been studied in depth for over five decades by researchers belonging to various disciplines, such as psychology, sociology, economics, anthropology, and organization theory (Rogers, 1995). The focus of early research was on theory development, while more recent research has broadened innovation theory. A primary objective in this field of study as it relates to organizations is to specifically identify the innovation characteristics, organizational characteristics, and the external influences that affect the success or failure of innovations.

At present there is no 'general theory' of innovation (Read, 2000). Despite extensive research from the various fields, it has been difficult to unite the fragmented thinking into one umbrella theory. This may be due to the complexity of innovation (Read, 2000). Because researchers come from many different academic fields and often study specific components of innovation, a unifying general theory has yet to emerge. Many researchers believe a general theory is impossible due to the many complexities of innovation (Wolfe, 1994:406).

A variety of approaches has been used to study innovation adoption. For example, Gopalakrishnan and Bierly (2001) used a combination of the theory of organizational learning and theory of knowledge to analyze innovation adoption in the commercial banking industry. Moreover, Systems Theory was used by Read (2000) to determine what the research identifies as the main determinants of successful adoption of differing innovation typologies. Perhaps one of the most prevalent methods of studying innovation adoption and implementation that this researcher found in the literature is within the context of Diffusion of Innovation Theory, which will be discussed later in this

chapter. Although each of these approaches differs from one another, they all seek to provide an explanation why particular innovations are adopted.

Innovation Defined.

One of the initial difficulties in innovation research is defining exactly what innovation is. For example, Damanpour, in his organizational innovation meta-analysis, defines innovation as “the adoption of an idea or behavior, whether a system, policy, program, device, process, product or service, that is new to the organization” (Damanpour, 1991:397). Conversely, Ravichandran contends that Damanpour’s definition equates ‘innovation’ with ‘adoption’ and that the former was used as a cover term for the latter. Additionally, he states “studying adoptions in the name of innovations will result in content fallacy and contextual fallacy” (Ravichandran, 2000:257). Everett M. Rogers, arguably one of the most prominent innovation researchers, provides a simple and concise definition of innovation in his fourth edition of *Diffusion of Innovations*. He defines innovation as “an idea, practice, or object that is perceived as new by an individual or another unit of adoption” (Rogers, 1995:11). Although Damanpour’s and Rogers’ definitions of innovation are slightly different, the common element in both definitions is that what matters is whether the innovation (idea, process, product, or practice) is new according to the perceiving individual or adopting unit.

Types of Innovation

Not all innovations are the same. Accordingly, they are frequently classified into typologies as a means of identifying their innovative characteristics or degree of innovativeness (Garcia and Calantone, 2002:117). In studies of innovation, there is a

need to differentiate between various categories of innovations so that consistency in the comparisons of findings can be maintained. Additionally, different types of innovations go through different types of adoption processes and have different determinants (Damanpour, 1987). A dichotomous classification is mainly used and prevalent in the literature. There are three distinct pairs of innovation types: product and process, technical and administrative, and radical and incremental.

Product/Process.

Product innovations are improved or new products, equipment, or services introduced to meet an external user or market need (Damanpour, 2001:47). Process innovations are those that improve organizational processes. They introduce new elements into organizational operations to support the production of a product or service (Ettlie and Reza, 1992). Product innovations have a market focus and are primarily customer driven, while process innovations have an internal focus and are primarily efficiency driven.

Technical/Administrative.

Technological innovations are the in-house development of new process technology, or the adoption and implementation of technology developed elsewhere, usually requires organizational adaptation, but does not need to be linked to new product or new market development (Boer and Daring, 2001:84). Administrative innovations are defined as those that occur in the administrative component and affect the social system of an organization (Damanpour et al, 1989:588). Administrative innovations constitute the introduction of a new management system, administrative process, or staff development program. An administrative innovation does not provide a new product or a

new service, but it indirectly influences the introduction of products or services or the process of producing them (Kimberly and Evanisko, 1982).

Radical/Incremental.

Innovations can be classified by the degree of change they seek to implement to an existing product, process, or practice within an organization (Damanpour, 1991:561). Radical or transformational innovations are those that seek to initiate fundamental departure from current projects, products, or procedures of organizations. Additionally, radical innovations often do not address a recognized demand but instead create a demand previously unrecognized by the consumer. This new demand cultivates new industries with new competitors, firms, distribution channels, and new marketing activities (Garcia and Calantone, 2002:121). Incremental innovations are those that seek smaller scale departures from existing organization practices (Damanpour, 1988:550). Wilson et al (1999), citing Munson and Pelz (1979) and Nord and Tucker (1987), state that an incremental innovation involves a minor improvement or adjustment in current technology and it often involves only minor changes in the task system that can be accommodated without major adjustment in the organizational system.

Diffusion of Innovation Theory

The Diffusion of Innovation theoretical framework has its early roots in rural sociology where it was developed to explain and predict how agricultural innovations were diffused. It has since been tested and refined in nearly 4,000 published studies of innovation adoption across a wide range of scholarly disciplines (Rogers, 1995:xv).

Diffusion, as Rogers defines the term, is “the process by which an innovation is communicated through certain channels over time among the members of a social system” (Rogers, 1995:5). This definition contains the four elements that are the foundations of diffusion of innovation theory: (1) the innovation, (2) communication channels, (3) time, and (4) social system. A brief description of each element is provided below.

1. *Innovation* An innovation is an idea, practice, or object that is perceived as new by an individual or another unit of adoption (Rogers, 1995:11).
2. *Communication Channels* A communication channel is the means by which messages get from one individual to another. The nature of the information-exchange relationship between a pair of individuals determines the conditions under which a source will or will not transmit the innovation to the receiver, and the effect of the transfer (Rogers, 1995:18).
3. *Time* The time dimension is involved in diffusion (1) in the innovation-decision process by which an individual passes from first knowledge of an innovation through its adoption or rejection, (2) in the innovativeness of an individual or other unit of adoption, and (3) in an innovation’s rate of adoption in a system (Rogers, 1995:20).
4. *Social System* A social system is a set of interrelated units that are engaged in joint problem-solving to accomplish a common goal. The members or units of a social system may be individuals, informal groups, organizations, and/or subsystems (Rogers, 1995:23).

Based on diffusion of innovation theory, two broad sets of activities in the innovation process are distinguished: initiation and implementation. The adoption decision separates initiation from implementation, and it involves the primary activity through which innovations are taken into use in the adopting units (Rogers, 1995). An explanation of each activity is provided later in this chapter.

Overall, Rogers identifies five sets of characteristics, called factors that affect innovation adoption. These are: (1) innovation factors; (2) individual factors; (3) task factors; (4) environmental factors; and (5) organizational factors. Because each factor is further decomposed into multiple items (traits), Rogers's (1995) model incorporates a total of 28 attributes. Many of these items are perceptual measures and are often included in innovation studies. In diffusion of innovation studies, these factors represent independent variables and the dependent variable is the likelihood or the propensity to adopt an innovation.

Innovation-Decision Process Model.

Diffusion scholars have long recognized that an individual's decision about an innovation is not an instantaneous act, but rather a process that occurs over time and consists of a series of actions and decisions. The Innovation-Decision Process, as depicted in Figure 1, is the process through which an individual passes from (1) first knowledge of an innovation, (2) to forming an attitude toward the innovation, (3) to a decision to adopt or reject, (4) to implementation of the new idea, and (5) to confirmation of this decision (Rogers, 1995:162). Each of these stages is defined below.

1. *Knowledge* When the decision-making unit learns of an innovation's existence and gains some understanding of how it functions.
2. *Persuasion* When the decision-making unit forms a favorable or unfavorable attitude toward the innovation.
3. *Decision* When the decision-making unit engages in activities that lead to a choice to adopt or reject the innovation.
4. *Implementation* When the decision-making unit puts an innovation to use.
5. *Confirmation* When a decision-making unit seeks reinforcement of an innovation decision that has been made.

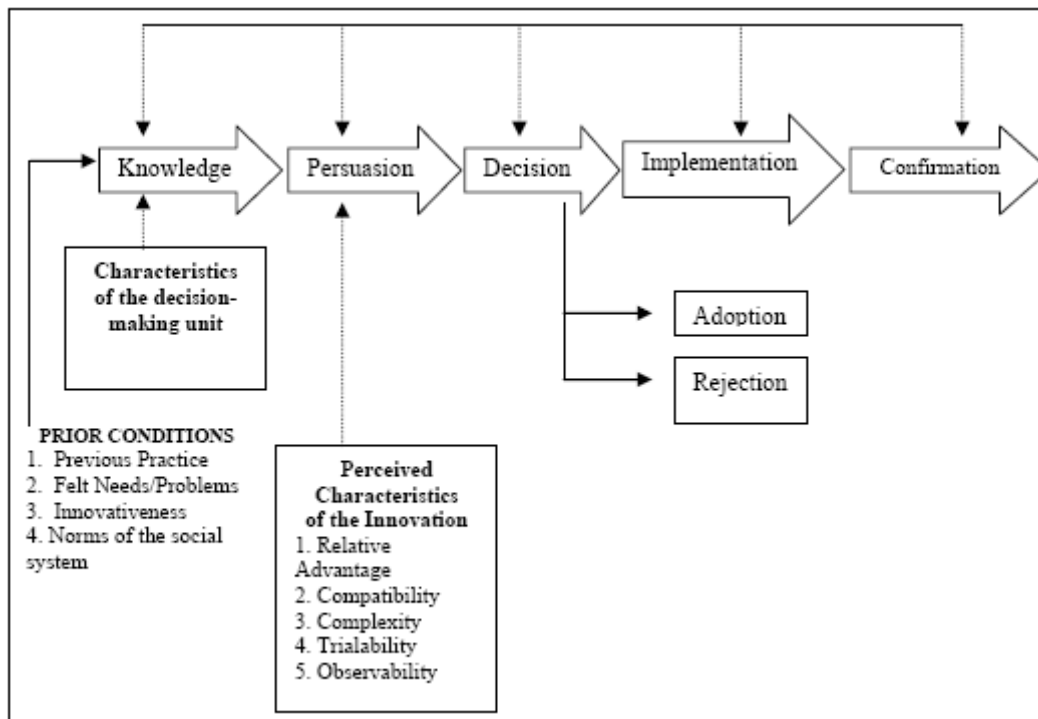

Figure 1. Innovation Decision Process Model (Rogers, 1995:162)

The first two stages of the model (knowledge and persuasion) can be characterized as the initiation activity in the overall innovation process, whereas the last two stages (implementation and confirmation) represent the implementation activity. The decision to either adopt or reject the innovation in stage 3 links the two activities together.

The decision to adopt or reject an innovation can fall into the following three categories: (1) optional innovation-decisions, (2) collective innovation-decisions, and (3) authority innovation-decisions. In both the optional and collective innovation-decisions, organizational members contribute their direct input into the adoption decision; however, authority adoption-decisions are made by a relatively few individuals in a system who possess power, status, or technical expertise (Rogers, 1995:29). Collective and authority decisions are much more common than optional decisions in government organizations.

Hypothesis Development

To this point, this chapter has provided a discussion on CRM, innovation, and Diffusion of Innovation Theory. It is important to conceptualize CRM, innovation, and innovation typology as applied to this research effort.

For the purpose of this research, the following CRM definition from ITtoolbox.com is adopted: “CRM includes the methodologies, strategies, software, and web-based capabilities that help an enterprise organize and manage customer relationships” (ITtoolbox.com, 2005). This definition was selected because, in addition to the importance of CRM methodologies and strategies an organization must develop, it also incorporates technology as a necessary tool to manage customer relations. The

Terminal 2010 program discussed in Chapter I will require the utilization of technology so aerial port organizations will be able to better interface with their customers and manage their relationships effectively.

This researcher also adopts the following definition of innovation: “innovation is an idea, practice, or object that is perceived as new by an individual or another unit of adoption” (Rogers, 1995:11). This definition is sufficiently broad to cover innovations throughout products, processes, and organizations and can be applied to various research disciplines. For these reasons, Rogers’ definition will be applied to this research effort.

As previously discussed, process innovations are those that improve organizational processes. They introduce new elements into organizational operations to support the production of a product or service (Ettlie and Reza, 1992). CRM is one such process innovation that utilizes technology to achieve the ultimate goal of managing customer relations and servicing customers in the most effective and efficient means possible.

Rogers’ Innovation-Decision Model provides a comprehensive framework that illustrates the stages through which an innovation passes from initial knowledge of the innovation through its implementation. Elements from the Diffusion of Innovation Theory (Rogers, 1995) will be used as a theoretical basis to identify and analyze factors that affect an organization’s propensity or intention to adopt a process innovation.

Although researchers often strive toward developing a comprehensive research model, incorporating all potentially important variables, this is often difficult. Such attempts often prove unwieldy, fail to provide any additional insight, or result in restricted data analysis due to sample size constraints (Lai and Guynes, 1997).

Additionally, the full diffusion of innovation process is comprised of so many factors that no single study has ever tested every factor (Russell and Hoag, 2004). The common research strategy is to choose a selection of hypothesized relationships among variables as appropriate for the research questions. Based on a review of the literature and the context of this research, the variables described in the next sections were chosen for this study.

The hypotheses selected for this research were drawn from two of Rogers' diffusion of innovation foundational elements—innovation characteristics and organizational characteristics. The hypotheses include six specific independent variables listed below and illustrate how each of these independent variables relates to the dependent variable—the propensity to adopt a CRM innovation. Before the proposed hypotheses are presented, each construct will be discussed based on a review of the literature.

Innovation Characteristics.

Many studies have examined the relationship between innovation characteristics and the success of the adoption and diffusion of innovations (Damanpour, 1987; Frambach, 1993; Frambach and Schillewaert, 2002; Kimberly and Evanisko, 1981; Rogers, 1995, Tornatzky and Klein, 1982). After an extensive review of innovation literature, Tornatzky and Klein claimed that it is possible to arrive at some generalization on the relationships between a few innovation characteristics and innovation adoption. They found that out of the 25 innovation characteristics that were evaluated by prior studies, the following ten attributes were most frequently studied by researchers: (1) compatibility, (2) relative advantage, (3) complexity, (4) cost, (5) communicability, (6)

divisibility, (7) profitability, (8) social approval, (9) trialability, and (10) observability. Their meta-analysis revealed that of these ten innovation characteristics, only three variables—relative advantage, compatibility, and complexity—were consistently found to be significant. Relative advantage and compatibility were positively related to innovation adoption and complexity was negatively related (Tornatzky and Klein, 1982:40). They also found relative advantage to be a key variable emerging consistently in practically all studies associated with adoption of innovations.

Relative Advantage.

The relative advantage of an innovation is “the degree to which an innovation is perceived as being better than the idea it supersedes” (Rogers, 1995:15). It can come in the form of better economic performance, time savings, and efficiency. The degree of relative advantage is often expressed as economic profitability, social prestige, or other benefits. The nature of the innovation determines what specific type of relative advantage is important to adopters, although the characteristics of the potential adopters also affect which subdimensions of relative advantage are most important (Rogers, 1995:212). The greater the perceived relative advantage of an innovation, the more rapid its rate of adoption will be.

Compatibility.

The compatibility of an innovation is “the degree to which an innovation is perceived as being consistent with the existing values, past experiences, and needs of the adopters” (Rogers, 1995:15). An idea that is more compatible is less uncertain to the potential adopter, and fits more closely with the individual’s life situation. Such compatibility helps the individual give meaning to the new idea so that it is regarded as

familiar. An innovation can be compatible or incompatible (1) with sociocultural values and beliefs, (2) with previously introduced ideas, or (3) with client needs for the innovation (Rogers, 1995:224). An idea that is compatible with the values and norms of a social system will be adopted more rapidly than an innovation that is incompatible.

Complexity.

The complexity of an innovation is “the degree to which an innovation is perceived as relatively difficult to understand and use” (Rogers, 1995:242). It is a perceived attribute of the innovation which is negatively related to innovation adoption. Therefore, if the perceived complexity of an innovation is low, organizations tend to adopt the innovation more rapidly. Some innovations are readily understood by most members of an organization, while other innovations are more complicated and will be adopted more slowly.

Organizational Characteristics.

In addition to the innovation characteristics, organizational characteristics are very influential to the innovation adoption decision and can be classified as direct influences on the decision to adopt an innovation. Damanpour (1991), in his organizational innovation research meta-analysis, presented a comprehensive list of 13 organizational determinants (organizational characteristics) found in prior research that have been empirically tested to be either positively or negatively related to innovation adoption. The ten positive organizational determinants are: (1) specialization, (2) functional differentiation, (3) professionalism, (4) managerial attitude toward change (including top management support for the innovation), (5) managerial tenure, (6) technical knowledge resources, (7) administrative intensity, (8) slack resources, (9)

external communication, and (10) internal communication. The three negative organizational determinants are: (1) formalization, (2) centralization, and (3) vertical differentiation. Of these 13 organizational determinants, innovation literature has consistently regarded top management support and internal communication as important factors in bringing about the changes required during the adoption and diffusion of an innovation (Prescott and Conger, 1995; Premkumar et al., 1994; Premkumar and Potter, 1995; Ruppel and Howard, 1998; Russell and Hoag, 2004; Williams, 2001; Wilson et al., 1999). Additionally, numerous studies have found that a risk-promoting climate (risk-readiness) is conducive to innovation adoption (Aiman-Smith et al., 2005; Ravichandran, 2000; Wilson et al. 1999).

Top Management Support.

Damanpour (1991) found that managers' favorable attitude toward change leads to an organizational climate that is conducive to innovation. Managerial support is required in the adoption stage since this is when management decides that acquisition and development of relevant value-adding innovations should be a vital element of their organization's strategy. Wilson's et al. (1999) research corroborated Damanpour's meta-analysis results.

Risk-promoting Climate.

A risk-promoting climate is characterized as the willingness of an organization to invest in new products/processes under conditions of uncertainty, not because of compulsions of survival, but on account of its pursuit of excellence (Ravichandran, 1999). Again, top managers serve as a bridge between their organization and the technical environment. Their ideas and influence on organizational members mold the

decisions for the organization, setting the tone for the future of the organization. Top managers possess differing attitudes toward risk and innovation. Some top managers have conservative attitudes and use methods and technologies that have served them well in the past. Conversely, other managers are more apt to take risks, encourage risk taking from subordinates, and adopt more innovative techniques.

Internal Communication.

For an innovation to be successfully adopted and used, it is important for the users to become aware of the innovation and what it can do to improve their job. Providing information on the benefits from the innovation and potential improvement to the work environment could motivate users to adopt the innovation (Premkumar et al., 1994). As one of the foundations of Diffusion of Innovation Theory, and discussed earlier in this chapter, communication is important to ensure that aspects of the innovation are transmitted to individuals throughout the organization. Communication is the process by which an organization's members create and share information with one another in order to reach a mutual understanding about the innovation. A communication channel is the means by which messages get from one individual to another. In Diffusion of Innovation Theory, there are two types of communication channels: mass media and interpersonal (Rogers, 1995). Mass media channels are those means of transmitting messages that include radio, television, and newspapers, which enable a source of one or a few individuals to reach an audience of many (Rogers, 1995). Conversely, interpersonal channels involve a face-to-face exchange of information between two or more individuals. Of the two types of communication channels, interpersonal channels are more effective in persuading an individual to accept a new idea (Rogers, 1995).

Proposed Hypotheses

Each construct described above (relative advantage, compatibility, complexity, top management support, risk promoting climate, and communication) has been found to impact the adoptions of a variety of innovations. In this study, the relationship between these six variables and an organization's propensity to adopt a CRM process innovation was examined. The following hypotheses are presented in order to answer the primary research question identified in Chapter I:

Hypothesis 1 -- Hypotheses to support relationships between innovation characteristics and propensity to adopt a CRM innovation.

H1a: Perceived relative advantage is positively related to the propensity to adopt a CRM innovation.

H1b: Perceived compatibility is positively related to the propensity to adopt a CRM innovation.

H1c: Perceived complexity is negatively related to the propensity to adopt a CRM innovation.

Hypothesis 2 -- Hypotheses to support relationships between organizational characteristics and propensity to adopt a CRM innovation.

H2a: Top management support is positively related to the propensity to adopt a CRM innovation.

H2b: A risk promoting climate is positively related to the propensity to adopt a CRM innovation.

H2c: Internal communication is positively related to the propensity to adopt a CRM innovation.

Hypothesis 3 – The model as shown with relationships given is a good fit.

Innovation adoption hypotheses, in the context of Diffusion of Innovation Theory, have repeatedly used the relative advantage, compatibility, and complexity innovation characteristics to study organizational innovation adoption. Although the organizational characteristic constructs have varied from study to study, the constructs listed above have been shown to be strong indicators of an organization's propensity to adopt an innovation.

Proposed Research Model

Each construct described above plays an important role as a variable in the proposed research model depicted in Figure 2. There are seven variables in the model (Figure 2). Figure 2 also shows the proposed positive or negative relationships each independent variable has on the propensity to adopt dependent variable.

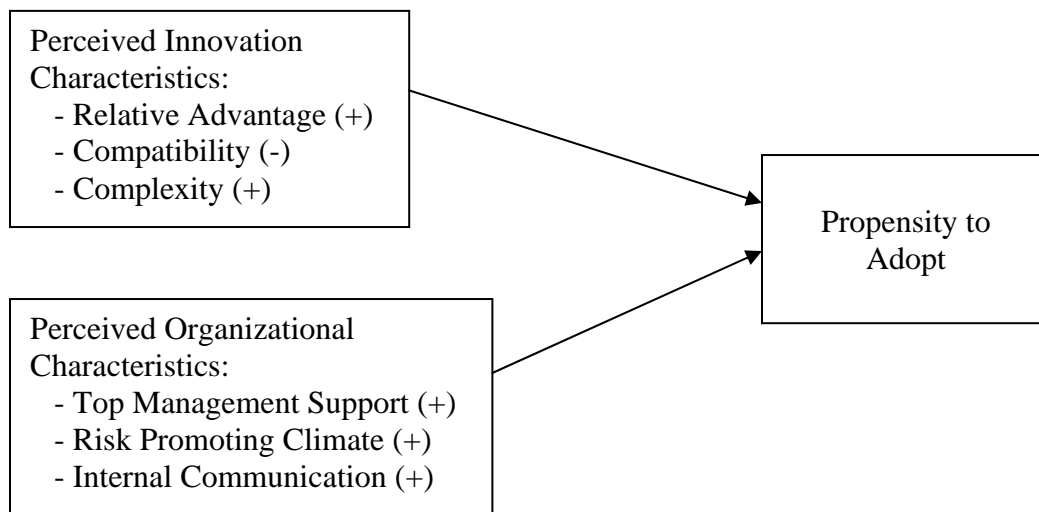

Figure 2. Proposed Innovation Adoption Model

Summary

This chapter provided a thorough review of the literature relevant to both customer relationship management (CRM) and organizational innovation adoption studies within the context of Diffusion of Innovation Theory. This review first gave a general overview of CRM. Next, innovation was discussed by exploring the following areas: innovation, innovation type, and Innovation Diffusion Theory. Following the innovation discussion, the review provided context for the research hypotheses by investigating the determinants of innovation adoption. Previous research was presented to examine the relationships between innovation and organizational characteristics and their subsequent relationships to an organization's propensity to adopt an innovation. Finally, the research hypotheses and model were proposed. The next chapter will describe the research methodology and the data analysis methods.

III. Methodology

Overview

This chapter describes the research method and data analysis used in this study to determine how specific innovation and organizational characteristics relate to the propensity of a single Air Force organization to adopt a customer relationship (CRM) management process innovation. The methodology was survey-based research using correlation analysis and multiple linear regression analysis to analyze the data.

In this chapter, the population under investigation is discussed followed by a description of the sampling method and a review of the survey instrument. Next, a discussion of the data collection procedures and specific measures used to assess the constructs of the research model are identified and validity and reliability issues are explained. Finally, a description of the data analysis method will be provided.

Population

The population under investigation in this research is the 81 personnel assigned to Headquarters, Air Mobility Command Air Transportation Division (AMC/A43) at Scott Air Force Base, Illinois. AMC/A43 is comprised of a mix of Air Force officers, enlisted personnel, and DoD civilians assigned to the following seven A43 branches: A43C Cargo Movement, A43D Business Management, A43E Aerial Port Equipment, A43I Transportation Systems, A43P Passenger Policy Branch, A43R Transportation Resources & Training, and A43T Traffic Management (see appendix A for organizational chart). The officers assigned to this organization are from the Logistics Readiness Officer (LRO)

career field and possess an extensive background in the transportation arena. The mission of AMC/A43 is to direct and advise policy, training, and procedures for all aspects of DoD cargo/passenger air transportation/movement and AMC traffic management (AMC, 2005). As discussed in Chapter I, AMC/A43 is seeking to adopt a CRM process innovation in order to implement the Terminal 2010 program.

Instrument Review

This section discusses the design of the data collection instrument used in this study, followed by the pretesting of the survey instrument, and finally, the modifications to the survey.

Survey Design.

Survey design includes all of the activities that precede data collection. In this stage the researcher should consider all of the possible shortcomings and difficulties and should find the right compromise between rigor and feasibility (Forza, 2002). A paper-based, self-administered survey was chosen as the instrument to collect data for this research.

Oftentimes information gathered in the social sciences, marketing, medicine, and business, relative to attitudes, emotions, opinions, personalities, and description's of people's environment involves the use of Likert-type scales (Gleim and Gleim, 2003). As individuals attempt to quantify constructs which are not directly measurable they frequently use multiple-item scales and summated ratings to quantify the construct(s) of interest. The Likert scale's invention is attributed to Rensis Likert, who described this technique for the assessment of attitudes (Gleim and Gleim, 2003).

As cited in Gleim and Gleim's study (2003), McIver and Carmines (1981)

describe the Likert scale as follows:

A set of items, composed of approximately an equal number of favorable and unfavorable statements concerning the attitude object, is given to a group of subjects. They are asked to respond to each statement in terms of their own degree of agreement or disagreement. Typically, they are instructed to select one of five responses: strongly agree, agree, undecided, disagree, or strongly disagree. The specific responses to the items are combined so that individuals with the most favorable attitudes will have the highest scores while individuals with the least favorable (or unfavorable) attitudes will have the lowest scores. While not all summated scales are created according to Likert's specific procedures, all such scales share the basic logic associated with Likert scaling.

Spector (1992) identified four characteristics that make a scale a summated rating scale as follows:

First, a scale must contain multiple items. The use of *summated* in the name implies that multiple items will be combined or summed. Second, each individual item must measure something that has an underlying, quantitative measurement continuum. In other words, it measures a property of something that can vary quantitatively rather than qualitatively. An attitude, for example, can vary from being very favorable to being very unfavorable. Third, each item has no "right" answer, which makes the summated rating scale different from a multiple-choice test. Thus summated rating scales cannot be used to test for knowledge or ability. Finally, each item in a scale is a statement, and respondents are asked to give a rating about each statement. This involves asking subjects to indicate which of several response choices best reflects their response to the item. (Spector, 1992:1-2)

Nunnally and Bernstein (1994), McIver and Carmines (1981), and Spector (1992) discuss the reasons for using multi-item measures instead of a single item for measuring psychological attributes. They identify the following:

First, individual items have considerable random measurement error, i.e. are unreliable. "Measurement error averages out when individual scores are summed to obtain a total score" (Nunnally and Bernstein, 1994:67). Second, an individual item can only categorize people into a relatively small number of groups. An individual item cannot discriminate among

fine degrees of an attribute. For example, with a dichotomously scored item one can only distinguish between two levels of the attribute, i.e. they lack precision. Third, individual items lack scope. McIver and Carmines (1981:15) say, “It is very unlikely that a single item can fully represent a complex theoretical concept or any specific attribute for that matter”. The most fundamental problem with single item measures is not merely that they tend to be less valid, less accurate, and less reliable than their multi-item equivalents. It is rather, that the social scientist rarely has sufficient information to estimate their measurement properties. Thus their degree of validity, accuracy, and reliability is often unknowable.

To increase the degree of validity, accuracy, and reliability, a minimum of three item measures were used to evaluate each construct in this research.

Pretest.

After completing the survey design and conducting an extensive academician review, a sample of nine students assigned to the Air Force Institute of Technology (AFIT) at Wright Patterson Air Force Base, Ohio, pretested the survey instrument. The pretest participants were not members of the sample population used in this study due to research time constraints and the relatively small size of the sample population. However, four of the nine participants were LROs and were familiar with the mission of the organization under investigation. For the remaining five participants, whom did not have an Air Force transportation background, a thorough explanation of the mission and structure of AMC/A43 was provided. Customer relationship management (CRM) was clearly defined and explained to all of the pretest participants prior to completing the survey instrument. Additionally, a thorough description of the research objective was provided to the participants. The participants were closely observed during the administration of the survey to ensure that they clearly understood the instructions, the scales, and the questions. The pretest was conducted for a 5-day period beginning 28

November 2005. At the conclusion of the test, all nine students had completed the survey, with an overall response rate of 100%.

Survey Modifications.

As a result of the feedback received from the pretest participants, minor modifications were made to the survey's appearance and grammatical changes/clarifications were made to four questions. A complete copy of the survey can be found in Appendix C.

Data Collection

For this study, participants were surveyed during the December 2005-January 2006 time frame. The self-administered, paper-based surveys were hand-delivered by the researcher to the organization under investigation. The surveys were then distributed to all available members of the organization. Initially, the objective was to collect the completed surveys after a three-day period; however, an unexpectedly large portion of the organization's members were unavailable due to training and/or leave. Of the 81 surveys that were distributed, 30 were completed and returned within the three-day timeframe. In order to maximize the response rate, a point-of-contact (POC) was established at the location and the POC continued to administer the survey for two additional weeks. The researcher maintained contact with the POC throughout the process and the POC provided several updates during the two-week follow-up administration period. At the end of the two-week period, 20 more personnel had taken part in the survey and the POC mailed the completed surveys to the researcher. Of the 81 employees assigned to AMC/A43, a total of 50 personnel took part in this study,

corresponding to a 62% response rate. After thoroughly reviewing the 50 returned surveys for completeness, two surveys were deemed unusable due to numerous unanswered questions. Therefore, the data set for this research consisted of 48 returned surveys which were compiled and analyzed using SPSS version 13.0 statistical software.

Measures

In general, the validity of a measurement instrument is the extent to which the instrument measures what it is supposed to measure (Leedy and Ormrod, 2001:98). Construct validity is the extent to which an instrument measures a characteristic that cannot be directly observed but must instead be inferred from patterns in people's behavior (Leedy and Ormrod, 2001:98). Researchers frequently ensure validity by using constructs and questions from previously validated research. To construct a survey that was CRM-specific, 23 out of the 28 survey questions were composed by this researcher. Therefore, an alternative method was required to determine the validity of the measurement instrument. In order to determine the validity of this measurement instrument, Leedy and Ormrod (2001) suggest that the instrument should be reviewed and scrutinized by experts within the research field. An extensive academician review was conducted by an AFIT faculty member, who is well-versed in the fields of innovation and CRM. Although this approach does not guarantee the validity of the measurement instrument, it does increase the likelihood of validity (Leedy and Ormrod, 2001).

The reliability of a measurement instrument is the extent to which it yields consistent results when the characteristic being measured hasn't changed (Leedy and

Ormrod, 2001:99). In order to reduce potential errors associated with reliability, this research will rely on the internal consistency reliability estimate called Cronbach's alpha, which measures the extent to which all the items within a single construct yield similar results (Leedy and Ormrod, 2001). When using Likert-type scales it is imperative to calculate and report Cronbach's alpha coefficient for internal consistency reliability for any scales or subscales one may be using (Gleim and Gleim, 2003). The analysis of the data then must use these summated scales or subscales and not individual items. The closer Cronbach's alpha coefficient is to 1.0 the greater the internal consistency of the items in the scale. A Cronbach's alpha value of greater than .70 is considered the acceptable standard (Nunnally & Bernstein, 1994). George and Mallery (2003) provide the following rules of thumb:

> .9 – Excellent, > .8 – Good, > .7 – Acceptable, > .6 – Questionable, > .5 – Poor, and < .5 – Unacceptable

Each construct described below includes its respective Cronbach's alpha.

The survey taken by the participants was made up of seven constructs (relative advantage, compatibility, complexity, top management support, risk-promoting climate, internal communication, and propensity to adopt), which were identified in the previous chapter as significant variables in studies associated with adoption of innovations (Damanpour, 1987; Frambach, 1993; Frambach and Schillewaert, 2002; Kimberly and Evanisko, 1981; Prescott and Conger, 1995; Premkumar et al., 1994; Premkumar and Potter, 1995; Rogers, 1995; Ruppel and Howard, 1998; Russell and Hoag, 2004; Tornatzky and Klein, 1982; Williams, 2001; Wilson et al., 1999). The survey instrument included a total of 28 questions which was designed to measure each construct. Due to

the small population, demographic data was limited to grouping the respondents by military rank to ensure the respondent's anonymity. Table 1 provides a summary of the demographic data. The rank grouping was used to provide context concerning the makeup of the sample in conjunction with the survey results. The demographic data in Table 1 shows that DoD civilians provided the most survey responses, followed by the E-7 to E-9 rank group. This result was encouraging since DoD civilians typically possess a high degree of tenure in the organization and are well-versed in organizational operations. Additionally, the E-7 to E-9 rank group is comprised of AMC/A43 enlisted personnel who possess the most air transportation experience and are most likely to be familiar with the Terminal 2010 program. The following sections discuss how of each the seven constructs were measured.

Table 1. Demographic Data

Rank Group	Count
E1 to E4	0
E5 to E6	8
E7 to E9	12
CGO	6
FGO	4
Civilian	18
Total	48

Innovation Characteristics.

Based on the literature and prior studies that were explored in the previous chapter, three innovation characteristics were examined as influences on an organization's propensity to adopt a process innovation. The innovation characteristics included in this survey are relative advantage, compatibility, and complexity.

Relative Advantage.

This construct was designed to measure the individual's perception of the relative advantage of the CRM process innovation. These items were written for this study and have not been subjected to any previous reliability or validity tests. This subscale consisted of the following four items:

- *Customer service will improve with the adoption of a customer relationship management program*
- *More time will be required to address customer needs under the customer relationship management program*
- *My organization will be able to handle customer issues more effectively under a customer relationship management program*
- *My job of addressing customer issues will be easier with a customer relationship management program*

A score for this subscale was computed by averaging each individual's responses to the four items listed above. A respondent could have a score ranging from 1 to 5. A score of 1 indicates a low level of perceived relative advantage of the CRM process innovation, while a score of 5 indicates a high level of perceived relative advantage. The Item Statistics and Chronbach alpha coefficient for this subscale are provided in Table 2 and Table 3 respectively.

Table 2. Relative Advantage Item Statistics

	Mean	Std. Deviation	N
Question 5	4.0208	.88701	48
Question 12	3.8750	.84110	48
Question 17	3.6875	.94882	48
Question 25	3.8333	.90703	48

Table 3. Relative Advantage Reliability Statistics

Cronbach's Alpha	Cronbach's Alpha Based on Standardized Items	N of Items
.718	.728	4

Compatibility.

This construct was designed to measure the individual's perception of the compatibility of a CRM process with the existing values, past experiences, and needs of the adopting organization. These items were developed and written for this study and have not been subjected to any previous reliability or validity tests.

This subscale consisted of the following four items:

- *Good customer service is important in my organization*
- *The customer relationship management program will benefit my organization's operations*
- *A customer relationship management program is harmonious with organizational customer service goals*
- *A customer relationship management program is consistent with the existing values of my organization.*

A score for this subscale was computed by averaging each individual's responses to the four items listed above. A respondent could have a score ranging from 1 to 5. A score of 1 indicates a low level of perceived compatibility of the CRM process innovation with the existing values, past experiences, and needs of the adopters, while a score of 5

indicates a high level of perceived compatibility. The Item Statistics and Chronbach alpha coefficient for this subscale are provided in Table 4 and Table 5 respectively.

Table 4. Compatibility Item Statistics

	Mean	Std. Deviation	N
Question 2	4.4792	.74347	48
Question 10	3.8125	.91457	48
Question 20	4.0625	.97645	48
Question 27	3.8958	.88100	48

Table 5. Compatibility Reliability Statistics

Cronbach's Alpha	Cronbach's Alpha Based on Standardized Items	N of Items
.886	.889	4

Complexity.

This construct was designed to measure the individual's perception of how the CRM innovation is perceived with respect to how difficult it is to understand and use. These items were developed and written for this study and have not been subjected to any previous reliability or validity tests. This subscale consisted of the following three items:

- *I understand how a customer relationship management program will be used in my organization*
- *My organization has the necessary resources to implement a customer relationship management program effectively*

This question was specifically developed to measure if the CRM innovation was perceived as difficult to use to the point where significant

additional organizational resources would be required to adopt the innovation.

- *The implementation of a customer relationship management program into our existing processes will be easy to learn and use.*

A score for this subscale was computed by averaging each individual's responses to the three items listed above. A respondent could have a score ranging from 1 to 5. A score of 1 indicates a high level of perceived complexity of the CRM process innovation, while a score of 5 indicates a low level of perceived complexity. These items were reverse-coded for the data analysis. The Item Statistics and Chronbach alpha coefficient for this subscale are provided in Table 6 and Table 7 respectively.

Table 6. Complexity Item Statistics

	Mean	Std. Deviation	N
Question 7	2.5833	1.06857	48
Question 14	2.5417	.87418	48
Question 22	2.3958	1.06670	48

Table 7. Complexity Reliability Statistics

Cronbach's Alpha	Cronbach's Alpha Based on Standardized Items	N of Items
.799	.803	3

Organizational Characteristics.

Again, based on the literature and prior studies that were explored in the previous chapter, three adopter characteristics were examined as influences on an organization's

propensity to adopt a process innovation. The adopter characteristics included in this survey are top management support, risk-promoting climate, and communication.

Top Management Support.

This construct was designed to measure the individual’s perception of how top management within the organization is supporting or championing the CRM initiative. These items were developed and written for this study and have not been subjected to any previous reliability or validity tests. This subscale consisted of the following three items:

- *Leadership in my organization supports the customer relationship management initiative*
- *My supervisor supports the customer relationship management initiative*
- *Leadership in my organization is actively engaged in the development of the customer relationship management initiative*

A score for this subscale was computed by averaging each individual’s responses to the three items listed above. A respondent could have a score ranging from 1 to 5. A score of 1 indicates a low level of perceived top management support of the CRM process innovation, while a score of 5 indicates a high level of perceived top management support. The Item Statistics and Chronbach alpha coefficient for this subscale are provided in Table 8 and Table 9 respectively.

Table 8. Top Management Support Item Statistics

	Mean	Std. Deviation	N
Question 4	4.1042	.99444	48
Question 15	3.6042	1.02604	48
Question 24	3.8958	.85650	48

Table 9. Top Management Support Reliability Statistics

Cronbach's Alpha	Cronbach's Alpha Based on Standardized Items	N of Items
.833	.840	3

Risk-promoting Climate.

The risk-promoting climate construct was designed to measure the individual's perception of their organization's risk-taking culture. The questions for this subscale were extracted from the Value Innovation Potential Assessment Tool (VIPAT), which was developed by a subcommittee of the Industrial Research Institute's Research-on-Research to be used by organizations to assess their innovation potential (Aiman-Smith et al., 2005). The researchers reviewed the items for content validity and usability, and checked reliabilities using Chronbach's alpha. They reported a reliability coefficient of above .70, which is considered good for exploratory survey work. This subscale consisted of the following four items:

- *Being innovative is characteristic of my organization's culture*
- *Diversity of thought is encouraged in my organization*
- *My unit challenges old ways of doing business*
- *My organization's culture encourages members to try new ideas.*

A score for this subscale was computed by averaging each individual's responses to the four items listed above. A respondent could have a score ranging from 1 to 5. A score of 1 indicates a low level of perceived organizational risk-promoting climate, while a score of 5 indicates a high level of perceived organizational risk-promoting climate.

The Item Statistics and Chronbach alpha coefficient for this subscale are provided in Table 10 and Table 11 respectively.

Table 10. Risk-Promoting Climate Item Statistics

	Mean	Std. Deviation	N
Question 6	3.8750	1.06441	48
Question 13	3.8958	1.09621	48
Question 16	4.0208	.93375	48
Question 21	3.8750	1.08422	48

Table 11. Risk-Promoting Climate Reliability Statistics

Cronbach's Alpha	Cronbach's Alpha Based on Standardized Items	N of Items
.937	.938	4

Internal Communication.

This construct was designed to measure the individual's perception of how effectively the CRM innovation is communicated throughout the organization. These items were developed and written for this study and have not been subjected to any previous reliability or validity tests. This subscale consisted of the following four items:

- *I am familiar with the goals of our customer relationship management initiative*
- *My supervisor asks me for feedback regarding the customer relationship management initiative*
- *I feel that mostly everyone in my unit is adequately familiar with the customer relationship management initiative*

- *I am regularly updated on the progress of the customer relationship management initiative*

A score for this subscale was computed by averaging each individual's responses to the four items listed above. A respondent could have a score ranging from 1 to 5. A score of 1 indicates a low level of perceived communication (information sharing) about the CRM process innovation within the organization, while a score of 5 indicates a high level of perceived communication. The Item Statistics and Chronbach alpha coefficient for this subscale are provided in Table 12 and Table 13 respectively.

Table 12. Internal Communication Item Statistics

	Mean	Std. Deviation	N
Question 1	3.4167	1.25195	48
Question 9	3.1250	1.14157	48
Question 18	3.0417	1.28756	48
Question 23	3.2292	1.17128	48

Table 13. Internal Communication Reliability Statistics

Cronbach's Alpha	Cronbach's Alpha Based on Standardized Items	N of Items
.909	.911	4

Propensity to Adopt.

This construct was designed to measure the individual's perception of the organization's likelihood, or propensity to adopt a CRM innovation. With the exception of the last question listed below (Tabak and Barr, 1999), these items were developed and

written for this study and have not been subjected to any previous reliability or validity tests. This subscale consisted of the following six items:

- *It is likely that my organization will adopt a customer relationship management program*
- *My organization seeks to improve its effectiveness by adopting new and innovative ideas*
- *Innovations that are perceived to be beneficial to the organization (support its mission) are routinely adopted*
- *My organization's culture supports/fosters innovation and learning*
- *My organization pursues innovation opportunities that are aligned with its mission*
- *If the decision were totally up to you, what is the probability that you would adopt this innovation in your organization? Rate from 0% to 100%_____.*

A score for this subscale was computed by averaging each individual's responses to the first five items listed above. A respondent could have a score ranging from 1 to 5. A score of 1 indicates a low level of adoption propensity of the CRM process innovation, while a score of 5 indicates a high level of adoption propensity. While the last question above does not necessarily measure the organization's propensity to adopt, it does measure each individual's propensity to adopt, which can be used to substantiate the organization's propensity to adopt measure. This question was not included in the Chronbach's alpha calculation and it was also excluded from the data analysis described

in the next section. To convert the responses from percentages to an interval scale, the percentages were divided into the following five intervals:

<u>Percent Range</u>	<u>Likert Score</u>
0 to 20	1
21 to 40	2
41 to 60	3
61 to 80	4
81 to 100	5

The Item Statistics and Chronbach alpha coefficient for this subscale are provided in Table 14 and Table 15 respectively.

Table 14. Propensity to Adopt Item Statistics

	Mean	Std. Deviation	N
PTA3	3.9583	1.14777	48
PTA8	3.7500	1.13924	48
PTA11	3.7917	.89819	48
PTA19	3.9792	.91068	48
PTA26	3.9375	.97645	48

Table 15. Propensity to Adopt Reliability Statistics

Cronbach's Alpha	Cronbach's Alpha Based on Standardized Items	N of Items
.913	.914	5

Data Analysis

Correlation Analysis.

When the research objective is to test the degree and significance of the relationship between two variables from interval or ratio scales, the appropriate technique is either correlation or regression analysis (Alreck and Settle, 2004:324). Correlation analysis was performed in this research effort to identify the level of association between the independent variables described in the previous section with the propensity to adopt dependent variable. Alreck and Settle (2004) provide the following insight on correlation analysis:

Correlation analysis generates a single value, the correlation coefficient, which shows how much the two variables move together. The correlation coefficient is usually symbolized by the letter r . It ranges from a value of zero, indicating that there is no relationship between the variables, to a plus or a minus one, indicating a perfect linear relationship. The plus or minus sign on the correlation coefficient indicates the direction of the correlation. If the correlation is positive, the two move in the same direction. If it is negative, they move in the opposite direction. In other words, the plus or minus indicates a direct or inverse relationship between the two variables. The absolute value shows how much the two items are correlated or moving together. The closer to zero, the less the relationship, while the closer to one, the greater the relationship. Therefore, both the sign and the value of the correlation coefficient provide information about the relationship between the variables. (Alreck and Settle, 2004:323-324)

The most common correlation method is called the Pearson product-moment correlation, or just product-moment (PM) correlation (Alreck and Settle, 2004:326). In order to use the Pearson product-moment correlation method, data must be from either interval or ratio scales. The Likert scale data collected from the survey instrument represents the interval scale needed to perform the PM correlation analysis method.

Correlations with p-values less than or equal to .05 were considered significant. It should be noted that when using the sample correlation coefficient, r , to infer the nature of the relationship between x and y , two caveats exist: (1) A high correlation does not necessarily imply that a causal relationship exists between x and y —only that a linear trend may exist; (2) a low correlation does not necessarily imply that x and y are unrelated—only that x and y are not strongly linearly related (McClave et al, 2005:729). While correlation coefficients are normally reported as $r =$ (a value between -1 and +1), squaring them makes them easier to understand. The square of the coefficient (or r square) is equal to the percent of the variation in one variable that is related to the variation in the other.

Interpreting the “degree” or strength of the relationship between two variables using the correlation coefficient can be misleading because this coefficient doesn’t show what proportion of a perfect relationship the two variables have. The proportion of “*shared variance*” is actually indicated by the square of the correlation coefficient, and that is called the coefficient of *determination*. The coefficient of determination is symbolized by r^2 . (Alreck and Settle, 2004:325)

In addition to the correlation coefficient, the coefficient of determination, r^2 , will be used to give the proportion of the sample variation in the propensity to adopt dependent variable that can be explained, or attributed to, by using the independent variable as a predictor. The r^2 value is useful in developing quantitative relationships between variables, which can be used in prediction (Montgomery, 2001).

Multiple Linear Regression and Multicollinearity.

Deterministic models are used when it is believed that there is an exact relationship between the dependent or response variable (y) and the independent, or predictor, variable (x). When it is expected that there will be unexplained variation in the

model a probabilistic model is utilized that accounts for the random error (McClave et al., 2005:693). In simple linear regression there is only one predictor variable. Most applications of linear regression utilize models that are more complex. When there is more than one predictor variable, multiple linear regression is used to incorporate the additional predictors (McClave et al., 2005:768).

After significant correlations were identified, multiple linear regression analysis was attempted in order to determine the nature of the relationships and the relative importance of the predictor variables in their contribution to the variation of the dependent variable. However, a high degree of multicollinearity was detected between all of the independent variables. The following is a brief explanation of multicollinearity.

Often, two or more of the independent variables used in a regression model are highly correlated and contribute redundant information. When highly correlated independent variables exist, the regression results may be confusing and misleading (McClave et al., 2005).

The use of stepwise regression eliminates the inclusion of multicollinear independent variables in the final model by checking each variable against those already included in the model and excluding any highly correlated variables at each step (McClave et al., 2005). The following is a brief explanation of stepwise regression:

Stepwise regression requires two cutoff values, F_{in} and F_{out} . Frequently F_{in} is greater than F_{out} , making it relatively more difficult to add a regressor than to delete one. Stepwise regression is a modification of forward selection in which at each step all regressors entered into the model previously are reassessed via their partial F-statistics. A regressor added at an earlier step may now be redundant because of the relationships between it and regressors now in the equation. If the partial F-statistic for a variable is less than F_{out} , that variable is dropped from the model. (Montgomery et al., 2001:314)

The exclusion of one multicollinear variable at the expense of another does not imply that the excluded variable could not add value to the model on its own. Stepwise regression just ensures that the variable that adds the most explanatory power of the two is included. The absence of multicollinearity in the final model can be confirmed by checking the variance inflation factor (VIF) of each independent value.

Since all of the independent variables were significantly correlated with each other, stepwise regression was used to assess the fit of the model as a whole. Further discussion of the multicollinearity analysis will be provided in the next chapter.

Confounds to Inference

The participants of this study were either active members or civilian employees of the Air Force. It was necessary to ensure all survey administration and data collection be accomplished in strict compliance with the Code of Federal Regulations, title 32, part 219, section 101, paragraph (b) (2); Air Force Instruction (AFI) 36-201, Air Force Personnel Survey Program; AFI 37-132, Air Force Privacy Act Program; and AFI 40-402, Exemption from Human Experimentation Requirements. As a result, it was necessary to employ survey procedures that would prevent the information obtained to be linked to the participants. This required anonymity prevented the tracking of respondents and non-respondents. Therefore, it is difficult to determine if those who did not respond to the survey are different from those who did respond to the survey. Due to these issues, it cannot be determined if the data is biased as a result of non-response errors.

Summary

This chapter described the research method and data analysis used in this study to determine how specific influences related to the propensity of a single organization to adopt a customer relationship (CRM) management process innovation. The methodology was survey-based research using correlation analysis to analyze the data.

In this chapter, the population under investigation was discussed followed by a description of the sampling method and a review of the survey instrument. Next, a discussion of the data collection procedures and specific measures used to assess the constructs of the research hypotheses were identified and validity and reliability issues were explained. Finally, a description of the data analysis method was provided.

IV. Results and Analysis

Overview

This chapter is presented in three parts. First, descriptive statistics for the research variables are reported. Second, correlation analyses and multiple linear regression analyses were performed to identify the level and strength of association between the independent variables (relative advantage, compatibility, complexity, top management support, risk-promoting climate, and internal communication) to the dependent variable (propensity to adopt). Finally, an examination of each hypothesis is presented.

Descriptive Statistics

Descriptive statistics for the study variables are presented in Table 16. This table displays sample sizes, ranges, means, and standard deviations for all the innovation and organizational characteristic independent variables included in this research. Additionally, the propensity to adopt dependent variable is included in Table 16. Each respondent could have a score ranging from 1 to 5 for each independent and dependent variable subscale. For the innovation characteristics (relative advantage and compatibility), a score of 1 indicated a low level of perceived relative advantage and compatibility that the CRM process innovation brings to the organization. The relative advantage and compatibility mean scores (3.85 and 4.06 respectively) indicate that the survey respondents agree that the CRM process innovation will produce a relative advantage and that it is compatible with the existing values, past experiences, and needs of the organization. For the complexity innovation characteristic, which was reverse-

coded for the data analysis, a score of 1 indicated a high level of perceived complexity of the CRM process innovation. The complexity mean score (2.5) suggests that the survey respondents perceive the CRM process innovation as moderately complex. For all three organizational characteristics (top management support, risk-promoting climate, and communication), a score of 1 indicated: a low level of perceived support by top management for the CRM process innovation, a low level of perceived organizational risk-promoting climate, and a low level of perceived internal communication about the CRM initiative within the organization. The top management support mean score (3.87) indicates that the survey respondents agree that top management supports the CRM initiative. Similarly, the risk-promoting climate mean score (3.92) implies that survey respondents agree that the organizational climate is conducive to risk taking. Conversely, the internal communication mean score (3.20) suggests that the survey respondents neither agree nor disagree that aspects of the CRM initiative are communicated within the organization. For the dependent variable (propensity to adopt), a score of 1 indicated a low level of adoption propensity of the CRM process innovation within the organization. The propensity to adopt mean score (3.88) indicates that survey respondents agree that the organization is likely to adopt the CRM process innovation.

Table 16. Descriptive Statistics

	N	Range	Mean	Std. Deviation
Relative Advantage	48	2.50	3.8542	.66010
Compatibility	48	3.75	4.0625	.76231
Complexity	48	3.67	2.5069	.85050
Top Management Support	48	3.67	3.8681	.83295
Risk Promoting Climate	48	3.75	3.9167	.95974
Communication	48	4.00	3.2031	1.07641
Propensity To Adopt	48	3.60	3.8833	.87891
Valid N (listwise)	48			

Correlation Analyses

Correlation analysis was used to test Hypotheses 1 and 2. Table 17 presents the Pearson product-moment correlation coefficients between the innovation characteristics (relative advantage, compatibility, and complexity), the organizational characteristics (top management support, risk-promoting climate, and communication), and the propensity to adopt. As discussed in the previous chapter, the square of the correlation coefficient, r^2 , indicates the proportion of variance in one of the variables that is accounted for, explained, or predictable from the variance of scores of the other variable. The r^2 will be used to give the proportion of the sample variation in the propensity to adopt dependent variable that can be explained, or attributed to, by using the independent variable as a predictor. The following sections will provide an analysis of each hypothesis.

Table 17. Correlations

		Relative Advantage	Compatibility	Complexity	Top Management Support	Risk Promoting Climate	Communication	Propensity To Adopt
Relative Advantage	Pearson Correlation	1	**	**	**	**	**	**
	N	48						
Compatibility	Pearson Correlation	.658**	1	**	**	**	**	**
	Sig. (2-tailed)	.000						
	N	48	48					
Complexity	Pearson Correlation	-.674**	-.786**	1	**	**	**	**
	Sig. (2-tailed)	.000	.000					
	N	48	48	48				
Top Management Support	Pearson Correlation	.625**	.834**	-.781**	1	**	**	**
	Sig. (2-tailed)	.000	.000	.000				
	N	48	48	48	48			
Risk Promoting Climate	Pearson Correlation	.390**	.742**	-.568**	.696**	1	**	**
	Sig. (2-tailed)	.006	.000	.000	.000			
	N	48	48	48	48	48		
Communication	Pearson Correlation	.555**	.571**	-.799**	.742**	.489**	1	**
	Sig. (2-tailed)	.000	.000	.000	.000	.000		
	N	48	48	48	48	48	48	
Propensity To Adopt	Pearson Correlation	.467**	.792**	-.682**	.785**	.923**	.587**	1
	Sig. (2-tailed)	.001	.000	.000	.000	.000	.000	
	N	48	48	48	48	48	48	48

** . Correlation is significant at the 0.01 level (2-tailed).

Hypothesis 1 Analysis

Hypothesis 1 includes three sub-hypotheses to test the relationships between innovation characteristics and the propensity to adopt a CRM innovation. Specifically, Hypothesis 1 proposed that (a) a positive relationship existed between the perceived relative advantage and the propensity to adopt a CRM innovation, (b) a positive relationship existed between perceived compatibility and the propensity to adopt a CRM innovation motivation, and (c) a negative relationship existed between complexity and the propensity to adopt a CRM innovation.

As predicted, relative advantage and compatibility had a positive relationship with the propensity to adopt a CRM innovation. Table 17 indicates a significant positive relationship with correlation coefficients of $r = .467$ for relative advantage and $r = .792$ for compatibility. The coefficients of determination (r^2) for relative advantage and compatibility is $r^2 = .218$ and $r^2 = .627$ respectively, meaning that 21.8 percent of the variance on the propensity to adopt variable is associated with the variance of the scores on the relative advantage variable and 62.7 percent of the variance on the propensity to adopt variable is associated with the variance of the scores on the compatibility variable. The correlation coefficient of $r = -.682$ for the complexity variable indicates significant negative relationship with the propensity to adopt a CRM innovation. Additionally, the coefficient of determination for complexity was $r^2 = .465$, meaning that 46.5 percent of the variance on the propensity to adopt variable is associated with the variance of the scores on the complexity variable. Based on the analysis above, Hypothesis 1 is fully supported. Table 18 summarizes the results.

Table 18. Hypothesis 1 Summary

	Variable	Pearson Correlation	Significance	Result
Hypothesis 1a	Relative Advantage	0.467	0.001	Supported
Hypothesis 1b	Compatibility	0.658	0.000	Supported
Hypothesis 1c	Complexity	-0.682	0.000	Supported

Hypothesis 2 Analysis

Hypothesis 2 includes three sub-hypotheses to test the relationships between organizational characteristics and the propensity to adopt a CRM innovation. In particular, Hypothesis 2 proposed that: (a) a positive relationship existed between the perceived organizational top management support and the propensity to adopt a CRM innovation, (b) a positive relationship existed between perceived risk-promoting climate and the propensity to adopt a CRM innovation motivation, and (c) a positive relationship existed between communication and the propensity to adopt a CRM innovation.

As expected, all three organizational characteristic variables had a positive relationship with the propensity to adopt a CRM innovation. The correlation matrix (Table 14) indicates significant positive relationships for top management support, risk-promoting climate, and communication, with correlation coefficients of $r = .785$, $r = .923$, and $r = .587$ respectively. The coefficients of determination (r^2) for top management support, risk-promoting climate, and communication are $r^2 = .616$, $r^2 = .852$, and $r^2 = .345$ respectively. Therefore, .616 or 61.6 percent of the variance on the propensity to adopt variable is associated with the variance of the scores on the top management support variable, .852 or 85.2 percent of the variance on the propensity to adopt variable is associated with the variance of the scores on the risk-promoting climate

variable; and .345 or 34.5 percent of the variance on the propensity to adopt variable is associated with the variance of the scores on the communication variable. Based on the analysis above, Hypothesis 2 is fully supported. Table 19 summarizes the results.

Table 19. Hypothesis 2 Summary

	Variable	Pearson Correlation	Significance	Result
Hypothesis 2a	Top Management Support	0.785	0.000	Supported
Hypothesis 2b	Risk-promoting Climate	0.923	0.000	Supported
Hypothesis 2c	Internal Communication	0.587	0.000	Supported

Hypothesis 3 Analysis

Hypothesis 3 tested whether the model as shown with the relationships given is a good fit. The regression models in this section were analyzed in accordance with McClave et al's (2005:769) six step process for analyzing multiple regression models.

The steps in this process are:

Step 1. Hypothesize the deterministic component of the model and determine the independent variables to be included in the model.

Step 2. Use the sample data to estimate the unknown model parameters.

Step 3. Specify the probability distribution of the random error term and estimate the standard deviation of this distribution.

Step 4. Check that the assumptions on the random error term are satisfied.

- The mean of the probability distribution of ϵ , is 0
- The variance of the probability distribution of ϵ is constant for all settings of the independent variable x
- The probability distribution of ϵ is approximately normal
- The values of ϵ associated with any two observed values of y are independent

Step 5. Statistically evaluate the usefulness of the model.

Step 6. When satisfied that the model is useful, use it for prediction, estimation, and other purposes.

Regression Model #1.

In Regression Model 1, all of the independent variables (relative advantage, compatibility, complexity, top management support, risk-promoting climate, and internal communication) were regressed on the propensity to adopt dependent variable. This model is represented by equation 1.

$$y = \beta_0 + \beta_1x_1 + \beta_2x_2 + \beta_3x_3 + \beta_4x_4 + \beta_5x_5 + \beta_6x_6 + \epsilon \quad (1)$$

where

- y* = the dependent variable (propensity to adopt)
- β_0 = the y-intercept of the line
- β_1 is the slope of the line
- $\beta_{2...i}$ determines the contribution of x_i
- x_1 is the predictor variable relative advantage
- x_2 is the predictor variable compatibility
- x_3 is the predictor variable complexity
- x_4 is the predictor variable top management support
- x_5 is the predictor variable risk-promoting climate
- x_6 is the predictor variable internal communication
- ϵ is the random error component

The model represented by equation 1 was fit to the data using the statistical software package SPSS 13.0 for Windows. A summary of the SPSS output for this model is displayed in Table 20, and the full SPSS output for this model can be found in Appendix F.

Table 20. Regression Model 1 Summary

Model	R	R Square	Adjusted R Square	Std. Error of the Estimate
1	.948 ^a	.898	.883	.30024

- a. Predictors: (Constant), Communication, Risk Promoting Climate, Relative Advantage, Compatibility, Top Management Support, Complexity
- b. Dependent Variable: Propensity To Adopt

The adjusted r^2 value (.883) indicates a good model fit; however, as discussed in the previous chapter, multicollinearity was detected between all six independent variables. To detect multicollinearity in regression models, McClave et al. (2005:882) describe the following symptoms:

1. Significant correlations between pairs of independent variables
2. Nonsignificant t-tests for all (or nearly all) of the individual β parameters
3. Signs opposite from what is expected in the estimated β parameters

The correlation matrix (Table 17) indicates significant correlations between all of the independent variables. Additionally, the regression coefficients table (Appendix F) also displays nonsignificant t-test results for all but one of the individual β parameters. Risk-promoting climate is the only independent variable with a significant t-test result. Moreover, the same table displays signs opposite from what is expected in the estimated relative advantage and internal communication β parameters. Both the relative advantage and internal communication independent variables were expected to be positive.

In addition to examining the correlation matrix and regression coefficients table, the following techniques are used for detecting multicollinearity: (1) Variance Inflation Factor analysis, (2) Eigenvalue analysis, and (3) Condition Number analysis

(Montgomery, 2001). Below is a brief description of each technique.

1. *Variance Inflation Factor (VIF) Analysis.* The VIF for each term in the model measures the combined effect of the dependences among the regressors on the variance of that term. One or more large VIFs indicate multicollinearity. Practical experience indicates that if any of the VIFs exceeds 5 or 10, it is an indication that the associated regression coefficients are poorly estimated because of multicollinearity (Montgomery, 2001:337). However, some researchers become concerned when the VIF value is over 2.5 and the tolerance is under .40 (Williams, 2005).

2. *Eigenvalue Analysis*. When there is no multicollinearity at all, the eigenvalues will all equal one. As multicollinearity increases, eigenvalues will be both greater and smaller than 1 (eigenvalues close to zero indicate a multicollinearity problem), and the condition indices and the condition number will increase. (Williams, 2005:3)

3. *Condition Number Analysis*. The condition number is the condition index with the largest value. It equals the square root of the largest eigenvalue divided by the smallest eigenvalue. An informal rule of thumb is that if the condition number is 15, multicollinearity is a concern; if it is greater than 30 multicollinearity is a very serious concern. (Williams, 2005:3)

The regression coefficients table in Appendix F presents the tolerance levels and VIFs for each independent variable. With the exception of the relative advantage independent variable, all tolerances are under .40 and their associated VIFs exceed 2.5 indicating the presence of multicollinearity. Furthermore, the eigenvalues on the collinearity diagnostics table (Appendix F) for all independent variables are close to zero, which also indicates a multicollinearity problem. Finally, the condition number (55.727) is far greater than 30, indicating that multicollinearity is a very serious concern.

The combination of the above results indicated that the model is not statistically useful and prompted the use of stepwise regression for further analysis.

Regression Model #2.

In stepwise regression, an independent variable is entered into the model if the significance level of its F value is less than the entry value and it is removed if the significance level is greater than the removal value. Entry must be less than removal, and both values must be positive. In this stepwise regression, the entry value was .05 and the removal value was .10, resulting in two models.

The first model included risk-promoting climate as an independent variable, and the second model included risk-promoting climate and top management support as the independent variables. These models are represented by equation 2a and 2b.

$$y = \beta_0 + \beta_{1x_1} + \varepsilon \quad (2a)$$

$$y = \beta_0 + \beta_{1x_1} + \beta_{2x_2} + \varepsilon \quad (2b)$$

where

- y* is the *response variable (propensity to adopt)*
- β_0 is the *y-intercept of the line*
- β_i determines the contribution of *x_i*
- x₁* is the *predictor risk-promoting climate*
- x₂* is the *predictor variable top management support*
- ε is the *random error component*

A summary of the SPSS output for these models is displayed in Table 21, and the full SPSS output for the models can be found in Appendix G.

Table 21. Regression Model 2 Summary

Model	R	R Square	Adjusted R Square	Std. Error of the Estimate
1	.923 ^a	.851	.848	.34238
2	.944 ^b	.891	.886	.29671

- a. Predictors: (Constant), Risk Promoting Climate
- b. Predictors: (Constant), Risk Promoting Climate, Top Management Support
- c. Dependent Variable: Propensity To Adopt

Examination of the SPSS output (Appendix G) reveals that the standardized predicted and standardized residual means are approximately equal to 0, the residual standard deviation is approximately equal to the standard error of the estimate, the probability distribution of ε is approximately normal, and the values of ε associated with any two observed values of *y* appear to be independent. These results satisfy the standard regression random error assumptions. When conducting a global F-Test to statistically

evaluate the usefulness of the model, these random error assumptions must be met for the global F-Test to be valid (McClave et al., 2005). Additionally, an examination of the variance inflation factors on the regression coefficients table (Appendix G) indicates that no multicollinearity exists in these models.

The adjusted multiple coefficients of determination (r^2) for Models 2a and 2b are .848 and .886 respectively. These numbers reveal that the risk-promoting climate independent variable accounts for 84.8 percent of the variance in the propensity to adopt data, and both the risk-promoting climate and top management support independent variables account for 88.6 percent of the variance in the propensity to adopt data. Using the observed significance levels of the F statistics (.000) from the ANOVA table in the SPSS output (Appendix G), it is determined that both models are statistically useful. Therefore, Hypothesis 3 – The model as shown with relationships given is a good fit—is partially supported.

Summary

This chapter was presented in three parts. First, descriptive statistics for the research variables were reported. Second, correlation analyses and multiple linear regression analyses were performed to identify the level and strength of association between the independent variables (relative advantage, compatibility, complexity, top management support, risk-promoting climate, and internal communication) to the dependent variable (propensity to adopt). Finally, an examination of each hypothesis was presented. Chapter V will provide conclusions and recommendations based on the analysis presented in this chapter.

V. Conclusions and Recommendations

Overview

The focus of this research was to answer the following question: “Do individual perceptions of innovation characteristics (relative advantage, compatibility, and complexity) and organizational characteristics (top management support, risk-promoting climate, and internal communication) relate to an Air Force organization’s propensity to adopt a CRM process innovation?” Since organizational innovation adoption studies and CRM adoption studies in the USAF, within the context of Diffusion of Innovation Theory, could not be found, this research attempted to bridge this gap in the literature.

Three innovation characteristics from Diffusion of Innovation Theory and three organizational characteristics, which were found to be significant antecedents to innovation adoption in prior studies, were used to develop innovation adoption hypotheses. These hypotheses were then tested using correlation analysis and multiple linear regression analysis. This research sought to aid in increasing the understanding of the influences on CRM process innovation adoption within an Air Force organization.

Results of the Research

The results found in this study are consistent with the results found in the innovation adoption literature discussed in Chapter II. The Pearson product-moment correlation coefficients (Table 17) showed statistically significant relationships between all three of the innovation characteristic variables (relative advantage, compatibility, and complexity) and the propensity for the organization under investigation to adopt a CRM process innovation. Although all three innovation characteristic variables displayed a

statistically significant relationship with the dependent variable, the compatibility independent variable produced the highest correlation coefficient ($r = .792$). This result suggests that of the three innovation characteristics selected for this study, individual perceptions of the innovation compatibility—“the degree to which an innovation is perceived as being consistent with the existing values, past experiences, and needs of the adopters” (Rogers, 1995:15)—is the most important to the innovation-adopting organization under investigation.

The Pearson product-moment correlation coefficients (Table 17) also showed statistically significant relationships between all three organizational characteristic variables (top management support, risk-promoting climate, and internal communication) and the organizations’ propensity to adopt a CRM process innovation. Of the three organizational characteristic independent variables, risk-promoting climate—the willingness of an organization to invest in new products/processes under conditions of uncertainty, not because of compulsions of survival, but on account of its pursuit of excellence (Ravichandran, 1999)—produced the highest correlation coefficient ($r = .923$). Similar to the compatibility innovation characteristic, the risk-promoting climate organizational characteristic can be viewed as the most important to the organization under investigation.

The analysis presented here suggests that, individually, all of the innovation and organizational variables chosen for this research exhibit significant relationships and explain some of the variance in the organization’s propensity to adopt the CRM process innovation. However, as discussed in the previous chapter, the explanatory power of a multiple linear regression model, which included all of the innovation and organizational

characteristic variables, could not be determined due to the high degree of multicollinearity between all of the independent variables. Using stepwise regression, the proposed research model is partially supported with the inclusion of risk-promoting climate and top management support as the independent variables.

Recommendations

As the Air Force continues to transform its industrial age business processes to information age business processes, it is relying on the timely adoption and integration of new or improved technologies, capabilities, concepts, and processes—simply put, innovations. Therefore, it is important for Air Force leaders to understand that innovation and organizational characteristics exist and they should be considered prior to innovation adoption efforts. Furthermore, it is important that leaders understand that these characteristics either positively or negatively relate to the adoption of CRM process innovations.

Based on the results of this research and a thorough review of the findings in prior innovation adoption studies, the following are some recommendations that Air Force leaders can utilize to aid them in their potential CRM process innovation adoption efforts:

1. *Foster a Risk-Promoting Climate.* The favorable attitude toward risk taking by the organizational leader results in an organizational climate that is conducive to innovation. Leaders must recognize that change is a fundamental ingredient of Air Force transformation. Since transformation demands innovative thinking and risk-taking, it is essential that organizational leaders foster an environment where members can freely challenge old ways of doing business. This risk-promoting climate should also encourage members to try new ideas. As shown in this research, the leader's favorable

risk-taking attitude, which diffuses throughout the organization, positively influences an organization's propensity, or likelihood, to adopt a CRM process innovation.

2. *Develop Effective Internal Communication Channels.* For CRM process innovations to be successfully adopted in the Air Force, it is important for all potential users to become aware of the innovation. Additionally, organizational leaders can manage the perceptions of the innovation by communicating information on the benefits of the innovation and its potential improvements to the work environment.

This information can be communicated downward and laterally by a variety of means. For example, interpersonal communication channels in the form of meetings could be used to involve a face-to-face exchange of information about the innovation. Additionally, email could be used to ensure that all members of the organization, down to the lowest level, are aware of the innovation details. Once details about the innovation have been communicated to the entire organization, upward communication from the potential users can be used to provide leaders feedback on potential relative advantage, compatibility, and complexity issues. Regardless of method, effective internal communication could reduce uncertainty and motivate users to adopt the innovation.

Limitations of the Research

The generalizability of these findings should be viewed with caution since the sample was restricted to one Air Force organization seeking to adopt a specific innovation. The particular organization under investigation was relatively small when compared to other Air Force organizations. Using the same innovation and organizational variables may produce different results in different Air Force organizational settings.

Although the innovation and organizational variables chosen for this research were found to be significant as innovation adoption predictors in prior studies, there may also be other variables that could have significant relationships to an Air Force organization's propensity to adopt a CRM process innovation. As noted in Chapter II, incorporating all potentially important variables in a research effort is often difficult.

Future Research

Diffusion of Innovation Theory has provided a framework to study the innovation adoption process in both the public and private sectors. However, Air Force innovation adoption studies within the Diffusion of Innovation Theory framework could not be found in the literature. This research effort attempted to bridge the gap in the literature and provide a starting point for future Air Force innovation adoption research.

Accordingly, other innovation characteristic variables, such as trialability and observability, from Diffusion of Innovation Theory could be tested in Air Force organizational settings. These variables may also prove to be significantly related to an organization's propensity to adopt a CRM process innovation.

Prior research has also revealed many organizational characteristics that have been found to be significantly related to innovation adoption. Perhaps testing more of these organizational variables, such as specialization, formalization, and centralization, could provide additional insight to CRM process innovation adoption within the Air Force.

Finally, the Terminal 2010 program was in the development stage throughout the course of this research. As an extension of the AMC/A43 organization, the aerial port personnel will undoubtedly be affected by the adoption of a CRM program. A study of

aerial port personnel's perceptions of the innovation and organizational characteristics would provide a much larger sample and perhaps a more accurate picture of the organization's propensity to adopt the CRM process innovation.

Appendix A: AMC Logistics Directorate Organizational Chart

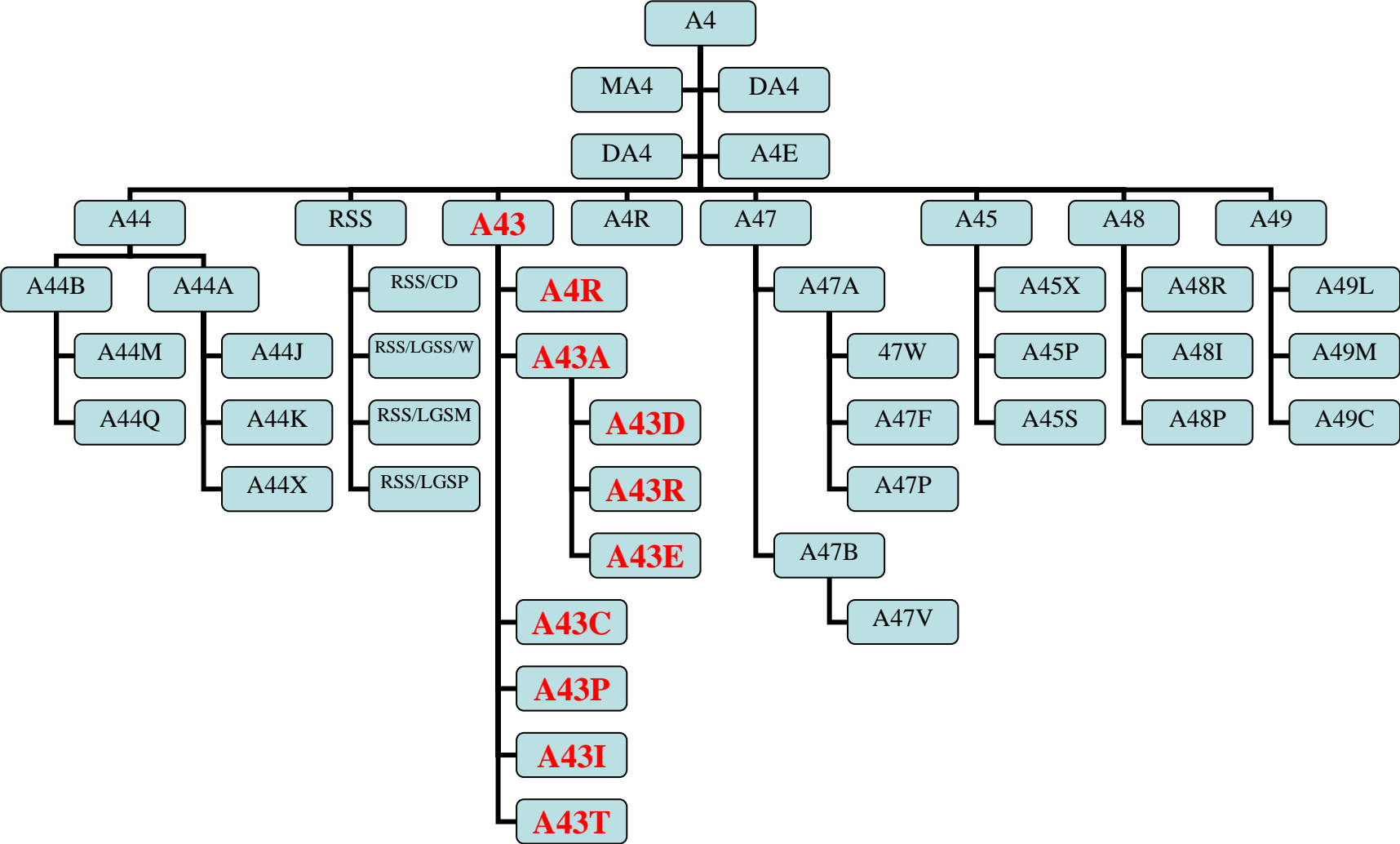

Appendix B: Survey Cover Letter

15 Dec 05

MEMORANDUM FOR SURVEY RESPONDENT

FROM: AFIT/ENS

SUBJECT: Customer Relationship Management (CRM) Survey

1. This survey is designed to examine your perceptions regarding the adoption of a CRM program within your division. Your participation in this survey is completely **voluntary and anonymous**.
2. This survey will provide vital information to Senior Air Force personnel in the Air Transportation Division (A43) of the Headquarters, Air Mobility Command Logistics Directorate, as well as other organizations seeking such initiatives. HQ AMC/A43 is sponsoring this survey and your participation has the potential to help shape future CRM implementations within the Air Force. It should take approximately 5 - 10 minutes to complete the survey. Please answer all questions as accurately as possible.
3. Please understand that your participation in this study is greatly appreciated, but not mandatory. When you are finished, please place the completed survey into the provided envelope and return it to the command section. If you have any questions regarding this survey, please contact Captain Evans by email at morgan.evans@afit.edu or by phone at DSN 255-6565/Commercial (937) 689-5922. I understand that your time is valuable. Again, your participation in this survey is greatly appreciated.

//SIGNED//

MORGAN J. EVANS, Capt, USAF
Graduate Student, AFIT/ENS/GLM

Attachment:
CRM Survey

Appendix C: Survey Instrument

Section 1 – Demographics

Please put an **X** in the circle next to your rank grouping.

1. Rank
 - E-1 to E-4
 - E-5 to E-6
 - E-7 to E-9
 - Company Grade Officer
 - Field Grade Officer
 - Civilian

Section 2 – Survey

Please circle a number from the scale below each of the following statements to show how much you agree or disagree with the item.

1. I am familiar with the goals of our customer relationship management initiative.

1	2	3	4	5
Strongly Disagree	Disagree	Neither	Agree	Strongly Agree

2. Good customer service is important in my organization.

1	2	3	4	5
Strongly Disagree	Disagree	Neither	Agree	Strongly Agree

3. My organization seeks to improve its effectiveness by adopting new and innovative ideas.

1	2	3	4	5
Strongly Disagree	Disagree	Neither	Agree	Strongly Agree

4. My supervisor supports the customer relationship management initiative.

1	2	3	4	5
Strongly Disagree	Disagree	Neither	Agree	Strongly Agree

5. Customer service will improve with the adoption of a customer relationship management program.

1 2 3 4 5
Strongly Disagree Disagree Neither Agree Strongly Agree

6. Being innovative is characteristic of my organization's culture.

1 2 3 4 5
Strongly Disagree Disagree Neither Agree Strongly Agree

7. I understand how a customer relationship management program will be used in my organization.

1 2 3 4 5
Strongly Disagree Disagree Neither Agree Strongly Agree

8. Innovations that are perceived to be beneficial to the organization (support its mission) are routinely adopted.

1 2 3 4 5
Strongly Disagree Disagree Neither Agree Strongly Agree

9. I am regularly updated on the progress of the customer relationship management initiative.

1 2 3 4 5
Strongly Disagree Disagree Neither Agree Strongly Agree

10. A customer relationship management program is harmonious with organizational customer service goals.

1 2 3 4 5
Strongly Disagree Disagree Neither Agree Strongly Agree

11. It is likely that my organization will implement a customer relationship management program.

1 2 3 4 5
Strongly Disagree Disagree Neither Agree Strongly Agree

12. My job of addressing customer issues will be easier with a customer relationship management program.

1 2 3 4 5
Strongly Disagree Disagree Neither Agree Strongly Agree

13. Diversity of thought is encouraged in my organization.
- | | | | | |
|--------------------------|-----------------|----------------|--------------|-----------------------|
| 1 | 2 | 3 | 4 | 5 |
| Strongly Disagree | Disagree | Neither | Agree | Strongly Agree |
14. The adoption of a customer relationship management program into our existing processes will be easy to learn and use.
- | | | | | |
|--------------------------|-----------------|----------------|--------------|-----------------------|
| 1 | 2 | 3 | 4 | 5 |
| Strongly Disagree | Disagree | Neither | Agree | Strongly Agree |
15. Leadership in my organization is actively engaged in the development of the customer relationship management initiative.
- | | | | | |
|--------------------------|-----------------|----------------|--------------|-----------------------|
| 1 | 2 | 3 | 4 | 5 |
| Strongly Disagree | Disagree | Neither | Agree | Strongly Agree |
16. My organization's culture encourages members to try new ideas.
- | | | | | |
|--------------------------|-----------------|----------------|--------------|-----------------------|
| 1 | 2 | 3 | 4 | 5 |
| Strongly Disagree | Disagree | Neither | Agree | Strongly Agree |
17. More time will be required to address customer needs under the customer relationship management program.
- | | | | | |
|--------------------------|-----------------|----------------|--------------|-----------------------|
| 1 | 2 | 3 | 4 | 5 |
| Strongly Disagree | Disagree | Neither | Agree | Strongly Agree |
18. I feel that mostly everyone in my organization is adequately familiar with the customer relationship management initiative.
- | | | | | |
|--------------------------|-----------------|----------------|--------------|-----------------------|
| 1 | 2 | 3 | 4 | 5 |
| Strongly Disagree | Disagree | Neither | Agree | Strongly Agree |
19. My organization's culture supports and fosters innovation and learning.
- | | | | | |
|--------------------------|-----------------|----------------|--------------|-----------------------|
| 1 | 2 | 3 | 4 | 5 |
| Strongly Disagree | Disagree | Neither | Agree | Strongly Agree |
20. A customer relationship management program will benefit my organization's operations.
- | | | | | |
|--------------------------|-----------------|----------------|--------------|-----------------------|
| 1 | 2 | 3 | 4 | 5 |
| Strongly Disagree | Disagree | Neither | Agree | Strongly Agree |

21. My organization's challenges old ways of doing business.
- | | | | | |
|--------------------------|-----------------|----------------|--------------|-----------------------|
| 1 | 2 | 3 | 4 | 5 |
| Strongly Disagree | Disagree | Neither | Agree | Strongly Agree |
22. My organization has the necessary resources to implement a customer relationship management program.
- | | | | | |
|--------------------------|-----------------|----------------|--------------|-----------------------|
| 1 | 2 | 3 | 4 | 5 |
| Strongly Disagree | Disagree | Neither | Agree | Strongly Agree |
23. My supervisor asks me for feedback regarding the customer relationship management initiative.
- | | | | | |
|--------------------------|-----------------|----------------|--------------|-----------------------|
| 1 | 2 | 3 | 4 | 5 |
| Strongly Disagree | Disagree | Neither | Agree | Strongly Agree |
24. Leadership in my organization supports the customer relationship management initiative.
- | | | | | |
|--------------------------|-----------------|----------------|--------------|-----------------------|
| 1 | 2 | 3 | 4 | 5 |
| Strongly Disagree | Disagree | Neither | Agree | Strongly Agree |
25. My organization will be able to handle customer issues more effectively under a customer relationship management program.
- | | | | | |
|--------------------------|-----------------|----------------|--------------|-----------------------|
| 1 | 2 | 3 | 4 | 5 |
| Strongly Disagree | Disagree | Neither | Agree | Strongly Agree |
26. My organization pursues innovation opportunities that are aligned with its mission.
- | | | | | |
|--------------------------|-----------------|----------------|--------------|-----------------------|
| 1 | 2 | 3 | 4 | 5 |
| Strongly Disagree | Disagree | Neither | Agree | Strongly Agree |
27. A customer relationship management program is consistent with the existing values of my organization.
- | | | | | |
|--------------------------|-----------------|----------------|--------------|-----------------------|
| 1 | 2 | 3 | 4 | 5 |
| Strongly Disagree | Disagree | Neither | Agree | Strongly Agree |
28. If the decision were totally up to you, what is the probability that you would adopt the customer relationship management program in your organization? Rate from 0% to 100% _____.

Appendix D: Frequency Tables

Innovation Characteristics

Relative Advantage

		Frequency	Percent	Valid Percent	Cumulative Percent
Valid	2.50	1	2.1	2.1	2.1
	2.75	1	2.1	2.1	4.2
	3.00	6	12.5	12.5	16.7
	3.25	6	12.5	12.5	29.2
	3.50	2	4.2	4.2	33.3
	3.75	9	18.8	18.8	52.1
	4.00	7	14.6	14.6	66.7
	4.25	6	12.5	12.5	79.2
	4.50	3	6.3	6.3	85.4
	4.75	2	4.2	4.2	89.6
	5.00	5	10.4	10.4	100.0
	Total	48	100.0	100.0	

Compatibility

		Frequency	Percent	Valid Percent	Cumulative Percent
Valid	1.25	1	2.1	2.1	2.1
	1.75	1	2.1	2.1	4.2
	3.00	1	2.1	2.1	6.3
	3.25	3	6.3	6.3	12.5
	3.50	3	6.3	6.3	18.8
	3.75	7	14.6	14.6	33.3
	4.00	7	14.6	14.6	47.9
	4.25	11	22.9	22.9	70.8
	4.50	2	4.2	4.2	75.0
	4.75	5	10.4	10.4	85.4
	5.00	7	14.6	14.6	100.0
	Total	48	100.0	100.0	

Complexity

		Frequency	Percent	Valid Percent	Cumulative Percent
Valid	1.00	3	6.3	6.3	6.3
	1.33	2	4.2	4.2	10.4
	1.67	5	10.4	10.4	20.8
	2.00	8	16.7	16.7	37.5
	2.33	6	12.5	12.5	50.0
	2.67	8	16.7	16.7	66.7
	3.00	6	12.5	12.5	79.2
	3.33	6	12.5	12.5	91.7
	3.67	1	2.1	2.1	93.8
	4.00	1	2.1	2.1	95.8
	4.67	2	4.2	4.2	100.0
	Total	48	100.0	100.0	

Organizational Characteristics

Top Management Support

		Frequency	Percent	Valid Percent	Cumulative Percent
Valid	1.33	1	2.1	2.1	2.1
	2.33	1	2.1	2.1	4.2
	2.67	1	2.1	2.1	6.3
	3.00	10	20.8	20.8	27.1
	3.33	2	4.2	4.2	31.3
	3.67	6	12.5	12.5	43.8
	4.00	8	16.7	16.7	60.4
	4.33	8	16.7	16.7	77.1
	4.67	3	6.3	6.3	83.3
	5.00	8	16.7	16.7	100.0
	Total	48	100.0	100.0	

Risk Promoting Climate

		Frequency	Percent	Valid Percent	Cumulative Percent
Valid	1.25	1	2.1	2.1	2.1
	1.50	1	2.1	2.1	4.2
	1.75	1	2.1	2.1	6.3
	2.00	1	2.1	2.1	8.3
	2.25	1	2.1	2.1	10.4
	2.50	2	4.2	4.2	14.6
	3.00	2	4.2	4.2	18.8
	3.50	1	2.1	2.1	20.8
	3.75	6	12.5	12.5	33.3
	4.00	9	18.8	18.8	52.1
	4.25	5	10.4	10.4	62.5
	4.50	8	16.7	16.7	79.2
	4.75	4	8.3	8.3	87.5
	5.00	6	12.5	12.5	100.0
	Total	48	100.0	100.0	

Communication

		Frequency	Percent	Valid Percent	Cumulative Percent
Valid	1.00	3	6.3	6.3	6.3
	1.75	2	4.2	4.2	10.4
	2.00	4	8.3	8.3	18.8
	2.25	1	2.1	2.1	20.8
	2.50	1	2.1	2.1	22.9
	2.75	7	14.6	14.6	37.5
	3.00	7	14.6	14.6	52.1
	3.25	3	6.3	6.3	58.3
	3.50	3	6.3	6.3	64.6
	3.75	3	6.3	6.3	70.8
	4.00	6	12.5	12.5	83.3
	4.50	1	2.1	2.1	85.4
	4.75	3	6.3	6.3	91.7
	5.00	4	8.3	8.3	100.0
	Total	48	100.0	100.0	

Dependent Variable

Propensity to Adopt

		Frequency	Percent	Valid Percent	Cumulative Percent
Valid	1.40	1	2.1	2.1	2.1
	1.60	1	2.1	2.1	4.2
	2.00	1	2.1	2.1	6.3
	2.40	1	2.1	2.1	8.3
	2.60	2	4.2	4.2	12.5
	3.00	3	6.3	6.3	18.8
	3.40	1	2.1	2.1	20.8
	3.60	5	10.4	10.4	31.3
	3.80	5	10.4	10.4	41.7
	4.00	8	16.7	16.7	58.3
	4.20	6	12.5	12.5	70.8
	4.60	5	10.4	10.4	81.3
	4.80	4	8.3	8.3	89.6
	5.00	5	10.4	10.4	100.0
	Total		48	100.0	100.0

Appendix E: Histograms

Relative Advantage

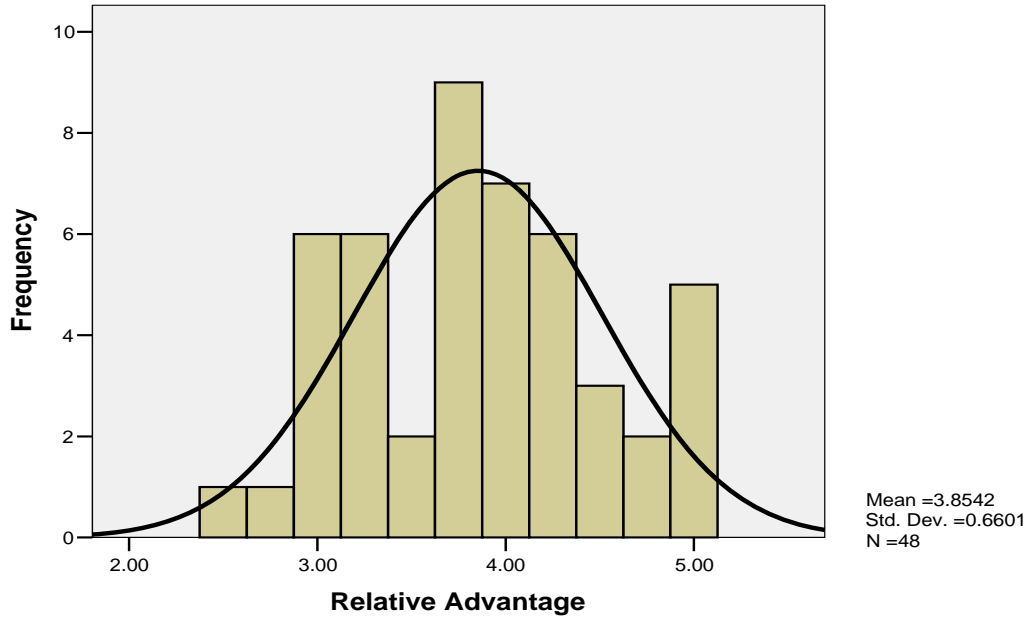

Compatibility

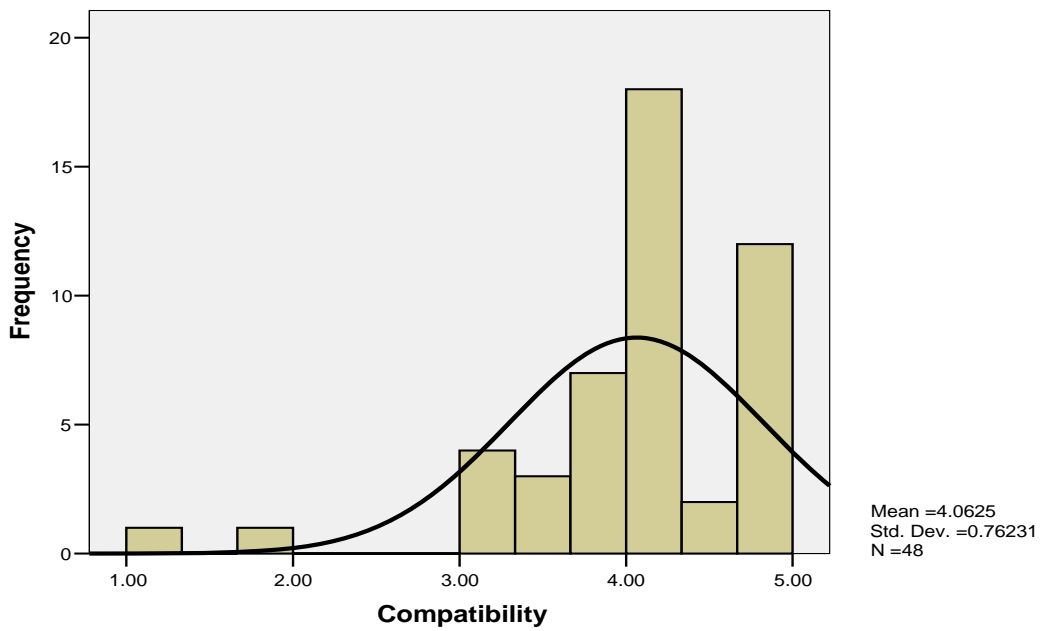

Complexity

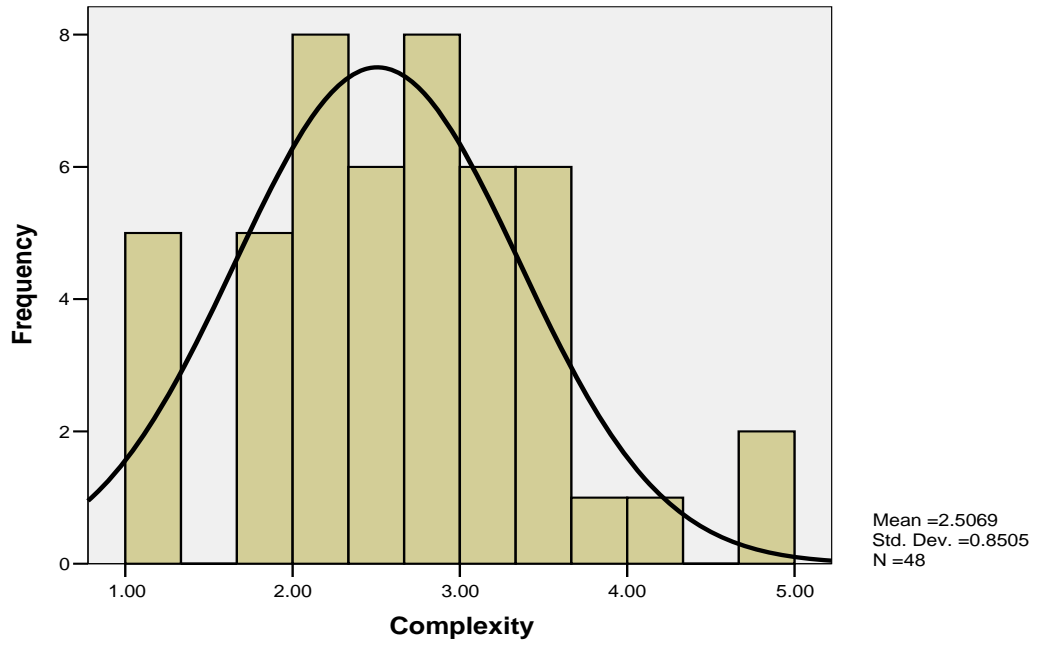

Top Management Support

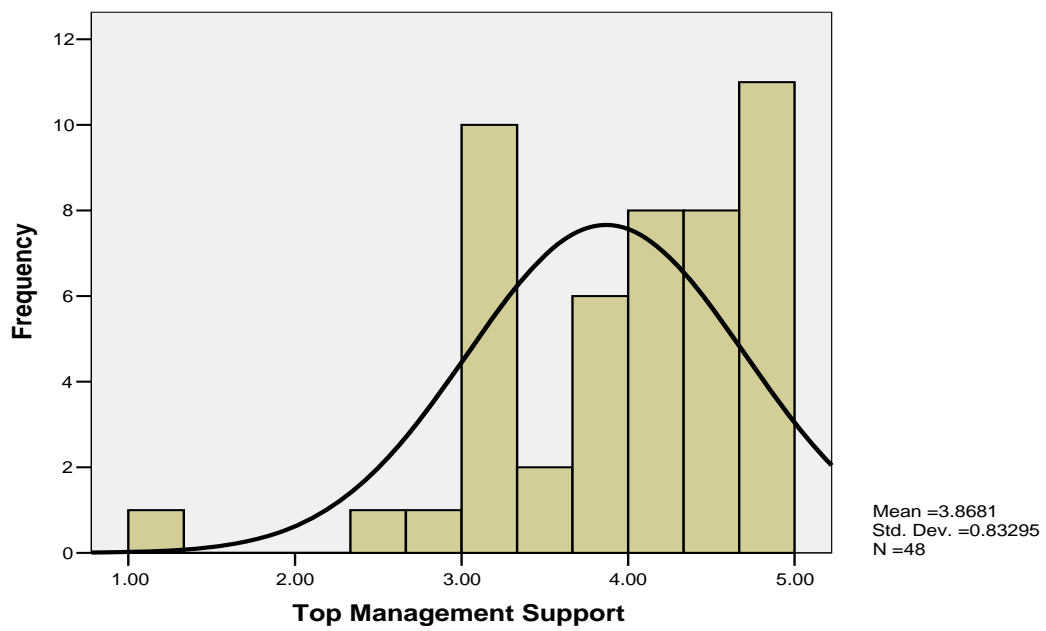

Risk Promoting Climate

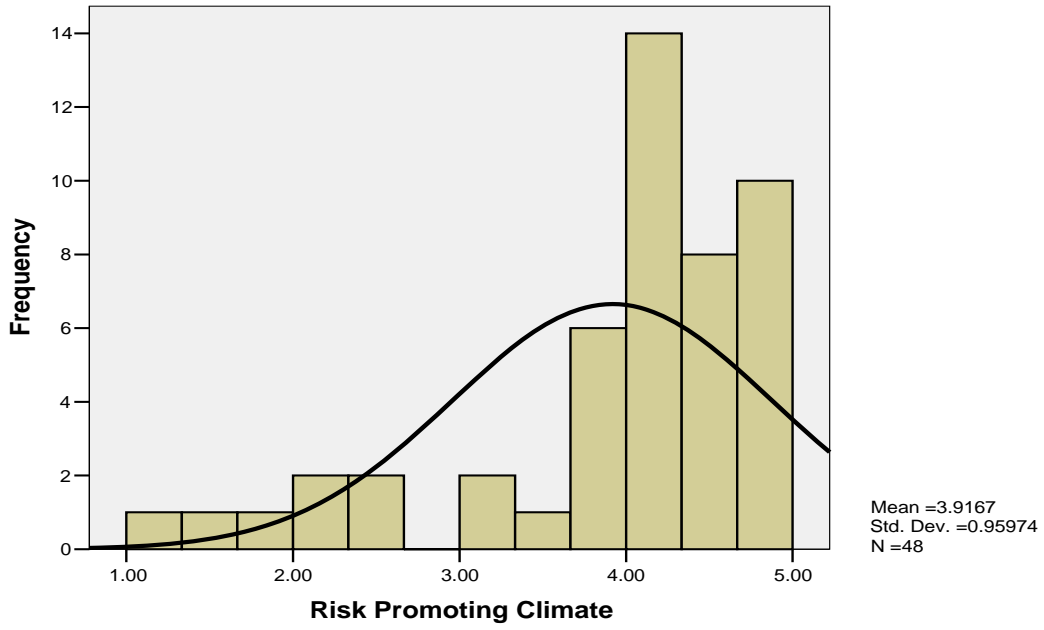

Communication

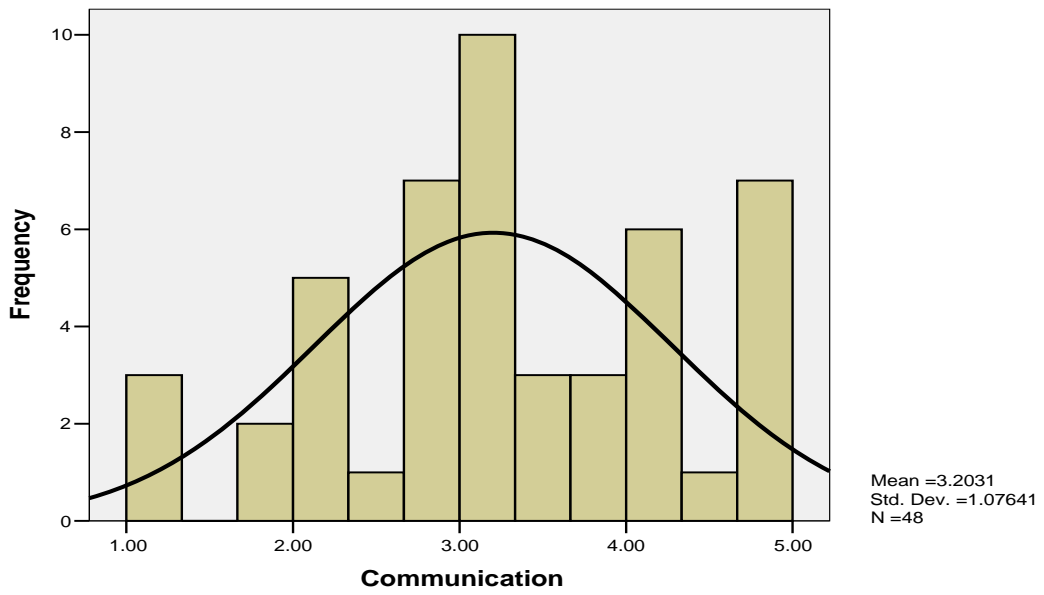

Propensity to Adopt

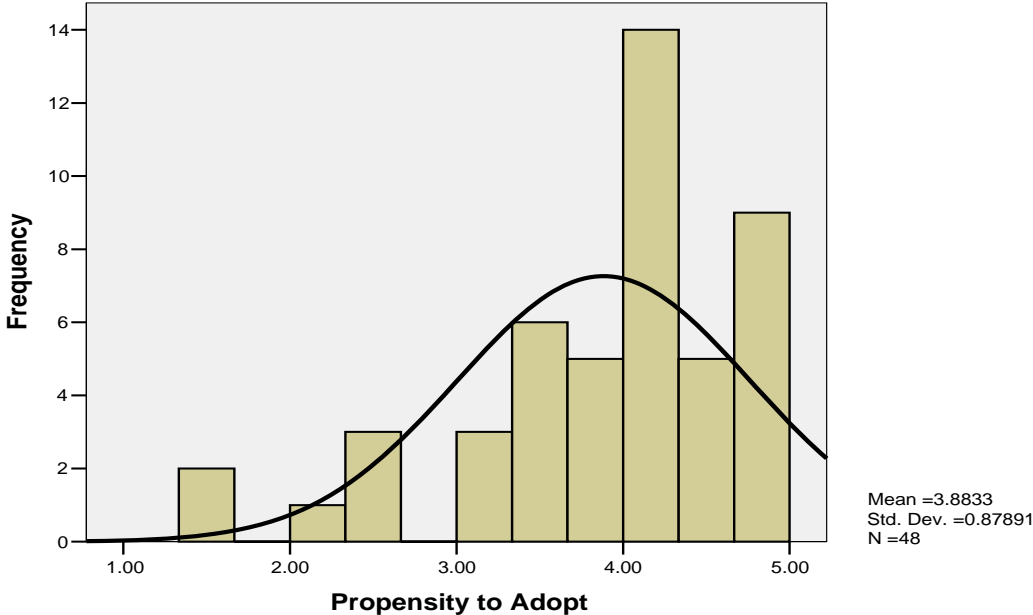

Appendix F: Detailed Results of Regression Model #1

Descriptive Statistics

	Mean	Std. Deviation	N
Propensity To Adopt	3.8833	.87891	48
Relative Advantage	3.8542	.66010	48
Compatibility	4.0625	.76231	48
Complexity	2.5069	.85050	48
Top Management Support	3.8681	.83295	48
Risk Promoting Climate	3.9167	.95974	48
Communication	3.2031	1.07641	48

Model Summary^b

Model	R	R Square	Adjusted R Square	Std. Error of the Estimate
1	.948 ^a	.898	.883	.30024

- a. Predictors: (Constant), Communication, Risk Promoting Climate, Relative Advantage, Compatibility, Top Management Support, Complexity
- b. Dependent Variable: Propensity To Adopt

ANOVA^b

Model		Sum of Squares	df	Mean Square	F	Sig.
1	Regression	32.611	6	5.435	60.295	.000 ^a
	Residual	3.696	41	.090		
	Total	36.307	47			

- a. Predictors: (Constant), Communication, Risk Promoting Climate, Relative Advantage, Compatibility, Top Management Support, Complexity
- b. Dependent Variable: Propensity To Adopt

Residuals Statistics^a

	Minimum	Maximum	Mean	Std. Deviation	N
Predicted Value	1.3263	4.9957	3.8833	.83297	48
Residual	-1.02345	.48490	.00000	.28042	48
Std. Predicted Value	-3.070	1.335	.000	1.000	48
Std. Residual	-3.409	1.615	.000	.934	48

- a. Dependent Variable: Propensity To Adopt

Coefficients

Model		Unstandardized Coefficients		Standardized Coefficients	t	Sig.	Correlations			Collinearity Statistics	
		B	Std. Error	Beta			Zero-order	Partial	Part	Tolerance	VIF
1	(Constant)	1.023	.788		1.299	.201					
	Relative Advantage	-.046	.096	-.034	-.476	.637	.467	-.074	-.024	.473	2.113
	Compatibility	.032	.143	.028	.223	.825	.792	.035	.011	.161	6.217
	Complexity	-.147	.118	-.142	-1.246	.220	-.682	-.191	-.062	.190	5.261
	Top Management Support	.192	.120	.181	1.596	.118	.785	.242	.080	.192	5.210
	Risk Promoting Climate	.652	.072	.712	9.023	.000	.923	.816	.450	.399	2.505
	Communication	-.005	.079	-.007	-.068	.946	.587	-.011	-.003	.263	3.804

a. Dependent Variable: Propensity To Adopt

Collinearity Diagnostics

Model	Dimension	Eigenvalue	Condition Index	Variance Proportions							
				(Constant)	Relative Advantage	Compatibility	Complexity	Top Management Support	Risk Promoting Climate	Communication	
1	1	6.706	1.000	.00	.00	.00	.00	.00	.00	.00	.00
	2	.218	5.548	.00	.00	.00	.06	.00	.00	.00	.02
	3	.038	13.359	.00	.00	.01	.01	.00	.00	.23	.32
	4	.022	17.322	.00	.27	.02	.04	.00	.00	.25	.19
	5	.009	27.197	.00	.38	.04	.00	.46	.00	.39	.03
	6	.005	36.489	.09	.31	.43	.05	.47	.09	.09	.05
	7	.002	55.727	.91	.04	.50	.84	.06	.03	.03	.38

a. Dependent Variable: Propensity To Adopt

Histogram

Dependent Variable: Propensity To Adopt

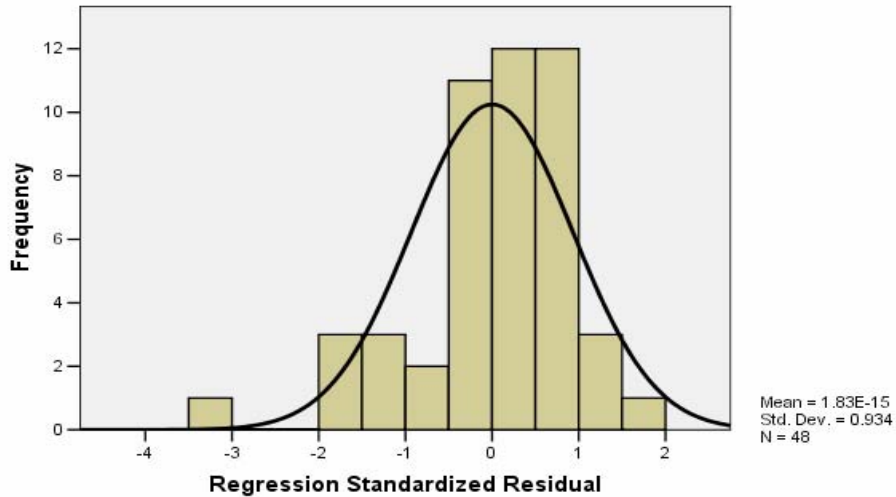

Normal P-P Plot of Regression Standardized Residual

Dependent Variable: Propensity To Adopt

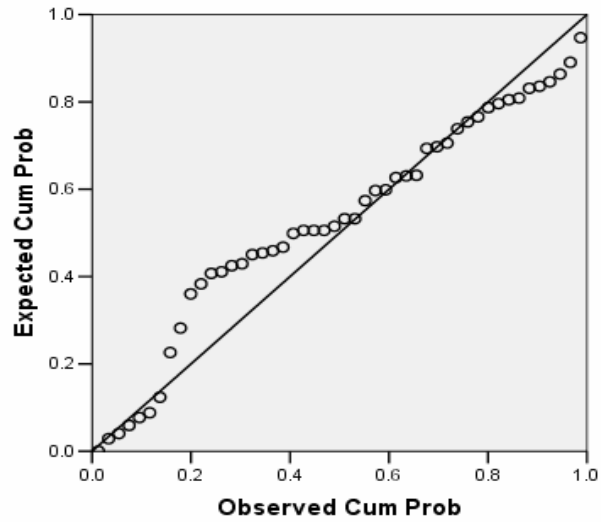

Dependent Variable: Propensity To Adopt

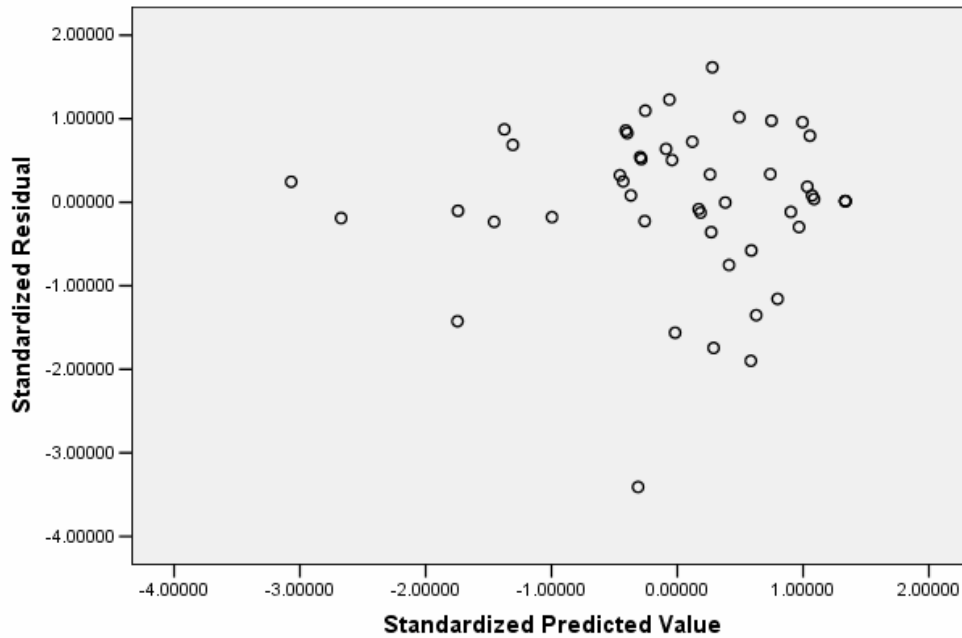

Appendix G: Detailed Results of Regression Model #2

Descriptive Statistics

	Mean	Std. Deviation	N
Propensity To Adopt	3.8833	.87891	48
Relative Advantage	3.8542	.66010	48
Compatibility	4.0625	.76231	48
Complexity	2.5069	.85050	48
Top Management Support	3.8681	.83295	48
Risk Promoting Climate	3.9167	.95974	48
Communication	3.2031	1.07641	48

Regression Model 2 Summary

Model	R	R Square	Adjusted R Square	Std. Error of the Estimate
1	.923 ^a	.851	.848	.34238
2	.944 ^b	.891	.886	.29671

- a. Predictors: (Constant), Risk Promoting Climate
- b. Predictors: (Constant), Risk Promoting Climate, Top Management Support
- c. Dependent Variable: Propensity To Adopt

ANOVA^c

Model		Sum of Squares	df	Mean Square	F	Sig.
1	Regression	30.915	1	30.915	263.728	.000 ^a
	Residual	5.392	46	.117		
	Total	36.307	47			
2	Regression	32.345	2	16.172	183.695	.000 ^b
	Residual	3.962	45	.088		
	Total	36.307	47			

- a. Predictors: (Constant), Risk Promoting Climate
- b. Predictors: (Constant), Risk Promoting Climate, Top Management Support
- c. Dependent Variable: Propensity To Adopt

Coefficients^a

Model		Unstandardized Coefficients		Standardized Coefficients	t	Sig.	Correlations			Collinearity Statistics	
		B	Std. Error	Beta			Zero-order	Partial	Part	Tolerance	VIF
1	(Constant)	.574	.210		2.735	.009					
	Risk Promoting Climate	.845	.052	.923	16.240	.000	.923	.923	.923	1.000	1.000
2	(Constant)	.135	.212		.639	.526					
	Risk Promoting Climate	.669	.063	.731	10.657	.000	.923	.846	.525	.516	1.938
	Top Management Support	.292	.072	.276	4.031	.000	.785	.515	.198	.516	1.938

a. Dependent Variable: Propensity To Adopt

Excluded Variables^c

Model		Beta In	t	Sig.	Partial Correlation	Collinearity Statistics		
						Tolerance	VIF	Minimum Tolerance
1	Relative Advantage	.127 ^a	2.129	.039	.302	.848	1.179	.848
	Compatibility	.240 ^a	3.085	.003	.418	.450	2.222	.450
	Complexity	-.233 ^a	-3.840	.000	-.497	.677	1.477	.677
	Top Management Support	.276 ^a	4.031	.000	.515	.516	1.938	.516
	Communication	.178 ^a	2.951	.005	.403	.761	1.315	.761
2	Relative Advantage	.016 ^b	.245	.808	.037	.605	1.653	.368
	Compatibility	.079 ^b	.806	.425	.121	.254	3.941	.254
	Complexity	-.131 ^b	-1.693	.097	-.247	.388	2.574	.296
	Communication	.054 ^b	.731	.468	.110	.447	2.235	.303

a. Predictors in the Model: (Constant), Risk Promoting Climate

b. Predictors in the Model: (Constant), Risk Promoting Climate, Top Management Support

c. Dependent Variable: Propensity To Adopt

Collinearity Diagnostics^a

Model	Dimension	Eigenvalue	Condition Index	Variance Proportions		
				(Constant)	Risk Promoting Climate	Top Management Support
1	1	1.972	1.000	.01	.01	
	2	.028	8.368	.99	.99	
2	1	2.956	1.000	.00	.00	.00
	2	.029	10.059	.88	.32	.04
	3	.014	14.325	.12	.68	.96

a. Dependent Variable: Propensity To Adopt

Residuals Statistics^a

	Minimum	Maximum	Mean	Std. Deviation	N
Predicted Value	1.3603	4.9381	3.8833	.82957	48
Residual	-.98881	.55238	.00000	.29033	48
Std. Predicted Value	-3.041	1.271	.000	1.000	48
Std. Residual	-3.333	1.862	.000	.978	48

a. Dependent Variable: Propensity To Adopt

Histogram

Dependent Variable: Propensity To Adopt

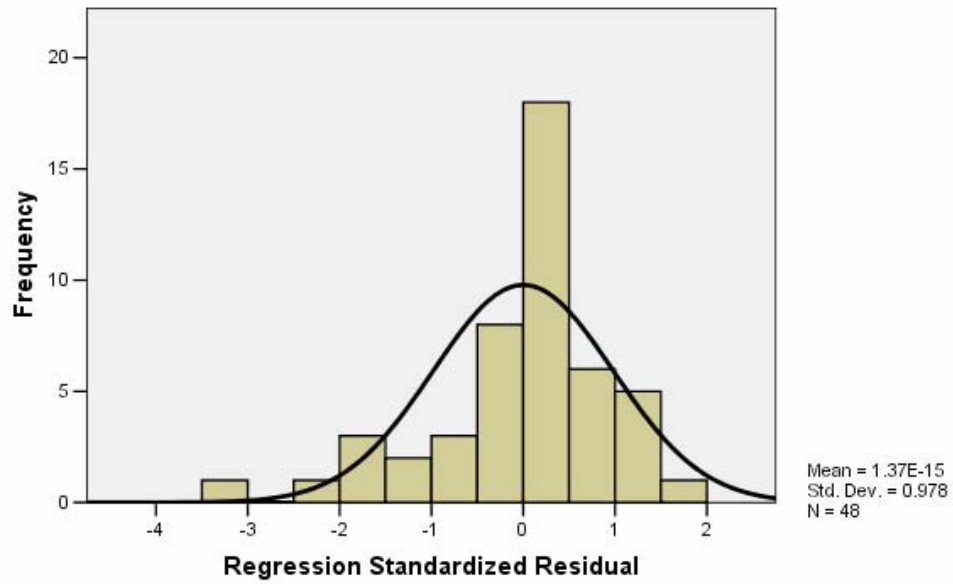

Normal P-P Plot of Regression Standardized Residual

Dependent Variable: Propensity To Adopt

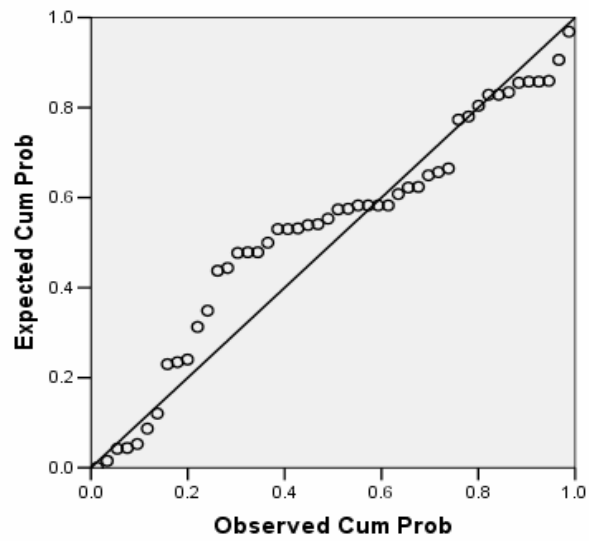

Scatterplot

Dependent Variable: Propensity To Adopt

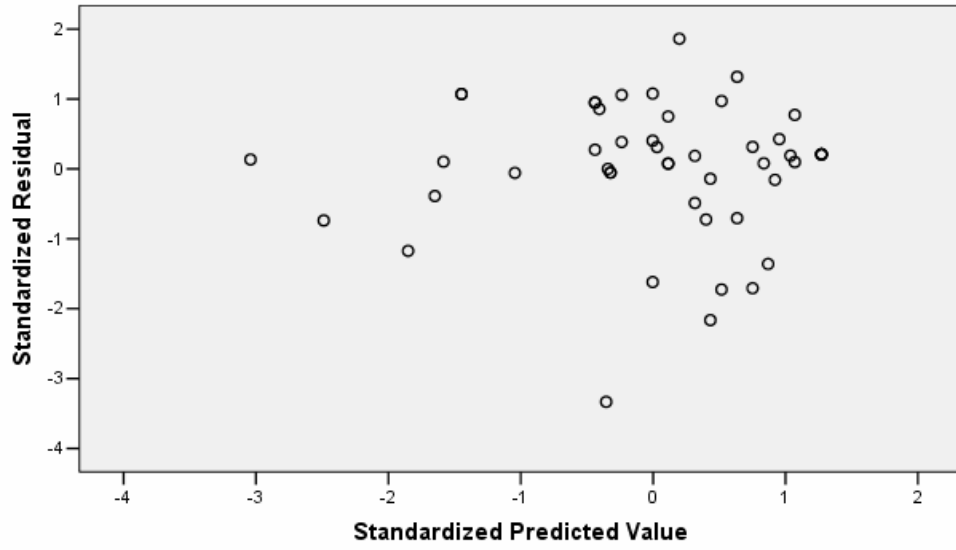

Bibliography

- Aiman-Smith, Lynda, Nina Goodrich, David Roberts, and James Scinta. "Assessing Your Organization's Potential for Value Innovation," *Research Technology Management*, 48: 37-42 (March-April 2005).
- [AMC] Air Mobility Command Air Transportation Division Vision Statement. AMC/A43 website. <https://amclg.scott.af.mil/a4-cgi-bin/index.pl?dd=/directorate/a43&ti=Air+Transportation>. 15 December 2005
- Boer, Harry, and Willem E. During. "Innovation, What Innovation? A Comparison Between Product, Process and Organizational Innovation," *International Journal of Technology Management*, 22: 83-107 (January 2001).
- Bose, Ranjit. "Customer Relationship Management: Key Components for IT Success," *Industrial Management and Data Systems*, 102: 89-97 (February 2002).
- Calder, Bobby J. and Edward C. Malthouse. "CRM and Relationship Branding," To appear in Kellogg on Branding, Wiley, 2005.
- [CONOPS] Headquarters, Air Mobility Command Air Transportation Division. The Terminal 2010 Concept of Operations, 18 January 2006.
- Damanpour, Fariborz. "Organizational Innovations: A Meta-analysis of Effects of Determinants and Moderators," *Academy of Management Journal*, 34: 555-590 (March 1991).
- "Organizational Size and Innovation," *Organization Studies*, 13: 375-402 (March 1992).
- "The Adoption of Technological, Administrative, and Ancillary Innovations: Impact of Organizational Factors," *Journal of Management*, 13: 675 (May 1987).
- Damanpour, Fariborz, Kathryn Szabat, and William Evan. "The Relationship Between Types of Innovation and Organizational Performance," *Journal of Management Studies*, 26: 587-601 (November 1989).
- Davids, Meryl. "How to Avoid the 10 Biggest Mistakes in CRM," *The Journal of Business Strategy*, 20: 22-26 (November 1999).
- Department of the Air Force. *The U. S. Air Force Transformation Flight Plan*. http://www.af.mil/library/posture/AF_TRANS_FLIGHT_PLAN-2003.pdf. November 2003.
- Dyche, J., *The CRM handbook* (4th edition). United States: Addison-Wesley, 2002.

- Ettlie, John E. and Ernesto Reza. "Organizational Integration and Process Innovation," *Academy of Management Journal*, 35: 795-827 (October 1992).
- Forza, Cipriano. "Survey Research in Operations Management: A Process-based Perspective," *International Journal of Operations & Production Management*, 22: 152-194 (Spring 2002).
- Frambach, Ruud T. "An Integrated Model of Organizational Adoption and Diffusion of Innovations," *European Journal of Marketing*, 27: 22-41 (May 1993).
- Frambach, Ruud T. and Niels Schillewaert. "Organizational Innovation Adoption. A Multi-level Framework of Determinants and Opportunities for Future Research," *Journal of Business Research*, 55: 163-176 (2002).
- Garcia, Rosanna and Roger Calantone. "A Critical Look at Technological Innovation Typology and Innovativeness Terminology: A Literature Review," *The Journal of Product Innovation Management*, 19: 110-132 (2002).
- Gleim, Joseph A. and Rosemary Gleim. "Calculating, Interpreting, and Reporting Chronbach's Alpha Reliability Coefficient for Likert-type Scales," Presented at the Midwest Research-to-Practice Conference in Adult, Continuing, and Community Education, The Ohio State University, Columbus, OH, October 8-10, 2003.
- Harej, Katja, and Romana Vajde Horvat. "Customer Relationship Management Momentum for Business Improvement," *26th International Conference on Information Technology Interfaces*, Cavtat, Croatia, 107-111 (June 2004).
- Kale, Sudhir. H. "CRM Failure and the Seven Deadly Sins," *Marketing Management*, 13: 42-46 (October 2004).
- Kimberly, John R. and Michail Evanisko. "Organizational Innovation: The Influence of Individual, Organizational, and Contextual Factors on Hospital Adoption of Technological and Administrative Innovations," *Academy of Management Journal*, 24: 689-713 (December 1981).
- Lai, Vincent S. and Jan L. Guynes. "An Assessment of the Influence of Organizational Characteristics on Information Technology Adoption Decision: A Discriminative Approach," *IEEE Transactions on Engineering Management*, 44: 146-157 (1997).
- Leedy, Paul D. and Jeanne Ormrod. *Practical Research: Planning and Design* (7th edition). Upper Saddle River, NJ: Prentice-Hall, Inc, 2001.
- McClave, James T., P. George Benson, and Terry Sincich. *Statistics for Business and Economics* (9th edition). Upper Saddle River, NJ: Prentice Hall, 2001.

- McIver, J. P., and E. G. Carmines. *Unidimensional Scaling*. Thousand Oaks, CA: Sage, 1981.
- Mirvis, Philip, Amy Sales, and Edward Hackett. "The Implementation and Adoption of New Technology in Organizations: The Impact on Work, People, and Culture," *Human Resource Management*, 30: 113-139 (Spring 1991).
- Missi, Farouk, Sarmad Alshawi, and Guy Fitzgerald. "Why CRM Efforts Fail? A Study of the Impact of Data Quality and Data Integration" *Proceedings of the 38th Hawaii International Conference on System Sciences (HICSS '05)*, Hawaii (2005).
- Montgomery, D. C. and others. *Introduction to Linear Regression Analysis* (3rd Edition). New York: John Wiley & Sons, Inc., 2001.
- Nord, W. R., and Tucker, S. *Implementing Routine and Radical Innovation*. Lexington, MA: Lexington Books, 1987.
- Nunnally, J. C., and Bernstein, I. H. *Psychometric Theory* (3rd edition). New York: McGraw-Hill, 1994.
- Ocker, Rosalie J. and Susan Mudambi. "Assessing the Readiness of Firms for CRM: A Literature Review and Research Model," *Proceedings of the 36th Hawaii International Conference on System Sciences (HICSS '03)*, Hawaii (2003).
- Peppers, Don and Martha Rogers. *Managing Customer Relationships: A Strategic Framework*. Hoboken, New Jersey: John Wiley & Sons, Inc., 2004.
- Premkumar, G., and Michael Potter. "Adoption of Computer Aided Software Engineering (CASE) Technology: An Innovation Adoption Perspective," *The DATABASE for Advances in Information Systems*, 26: 105-123 (Spring 1995).
- Premkumar, G., K. Ramamurthy, and Sree Nilakanta. "Implementation of Electronic Data Interchange: An Innovation Diffusion Perspective," *Journal Of Management Information Systems*, 11: 157-186 (Fall 1994).
- Prescott, Mary and Sue Conger. "Information Technology Innovations: A Classification by IT Locus of Impact and Research Approach," *Data Base*, 26: 20-41 (May/August 1995).
- Ravichandran, Thiruvencatam. "Redefining Organizational Innovation: Towards Theoretical Advancements," *The Journal of High Technology Management Research*, 10: 243-274 (Autumn 1999).
- Read, Anthony. "Determinants of Successful Organizational Innovation," *Journal of Management Practice*, 3: 95-119 (Winter 2000).

- Rigby Darrell, Frederick Reichheld, and Phil Schefter. "Avoid the Four Perils of CRM," *Harvard Business Review*, 80: 101-6, 108-9, 130 (February 2002).
- Rogers, Everett M. *Diffusion of Innovations*, (4th edition). New York: The Free Press, 1995.
- Ruppel, Cynthia P. and Geoffry Howard. "Facilitating Innovation Adoption and Diffusion: The Case of Telework," *Information Resources Management Journal*, 11: 5-15 (Summer 1998).
- Russell, Dawn M. and Anne Hoag. "People and Information Technology in the Supply Chain. Social and Organizational Influences on Adoption," *International Journal of Physical Distribution & Logistics Management*, 34: 102-122 (Spring 2004).
- Spector, P. *Summated Rating Scale Construction*. Thousand Oaks, CA: Sage, 1992.
- Tornatzky, Louis G. and Katherine Klein. "Innovation Characteristics and Innovation Adoption-Implementation: A Meta-Analysis of Findings," *IEEE Transactions on Engineering Management*, 28: 28-45 (February 1982).
- Wilson, Alla L., K. Ramamurthy, and Paul Nystrom. "A Multi-Attribute Measure for Innovation Adoption: The Context of Imaging Technology," *IEEE Transactions on Engineering Management*, 46: 311-321 (August 1999).
- Yu, Larry. "Successful Customer Relationship Management," *MIT Sloan Management Review*, 42: 18-19 (Summer 2001).
- Williams, R. "Multicollinearity." Excerpt from lecture.
<http://www.nd.edu/~rwilliam/xsoc593/lectures/111.pdf>. 1 February 2006.
- Winer, Russell S. "A Framework for Customer Relationship Management," *California Management Review*, 43: 89-105 (Summer 2001).
- Wolfe, Richard A. "Organizational Innovation: Review, Critique and Suggested Research Directions," *Journal of Management Studies*, 31: 405-431 (May 1994).
- Zablah, Alex, Danny Bellenger, and Wesley Johnston. "An Evaluation of Divergent Perspectives on Customer Relationship Management: Towards a Common Understanding of an Emerging Phenomenon," *Industrial Marketing Management*, 33: 475-489 (July 2004).

Vita

Captain Morgan J. Evans graduated from East Aurora High School in East Aurora, New York, in June 1984. After graduating from high school, he enlisted in the United States Air Force and attended Jet Engine Mechanic technical training at Chanute AFB, Illinois. Following technical school, he received an assignment to Seymour Johnson AFB, North Carolina, where he worked as a flightline jet engine mechanic on F-4E aircraft. In 1989, he was reassigned to Torrejon AB, Spain, and became an F-16 crew chief as a result of an Air Force Specialty Code merger. While at Torrejon AB, he deployed to Incirlik AB, Turkey, in support of Operation DESERT SHIELD and Operation DESERT STORM. Following assignments at Homestead AFB, FL, Shaw AFB, SC, and Osan AB, Korea, he was assigned to Eglin AFB where he completed his Community College of the Air Force Degree in Aircraft Maintenance Systems Technology. He was then assigned to Sheppard AFB, Texas, as an F-16 Crew Chief Technical School Instructor. He became an instructor supervisor and closed his enlisted career as the F-15 Mission Ready Apprentice Course Superintendent. He earned a Bachelor's Degree in Business Administration from Wayland Baptist University and was accepted to attend Officer Training School. On 17 November 2000, Master Sergeant Evans was commissioned and assumed the rank of Second Lieutenant. He then attended the Aircraft Maintenance Officer Course at Sheppard AFB, Texas, and upon completion, he was assigned to Spangdahlem Air Base, Germany. In August 2004 he entered the Graduate School of Engineering and Management, Air Force Institute of Technology. Upon graduation, he will be assigned to HQAMC/A44, Scott AFB, IL.

REPORT DOCUMENTATION PAGE			<i>Form Approved OMB No. 074-0188</i>	
<p>The public reporting burden for this collection of information is estimated to average 1 hour per response, including the time for reviewing instructions, searching existing data sources, gathering and maintaining the data needed, and completing and reviewing the collection of information. Send comments regarding this burden estimate or any other aspect of the collection of information, including suggestions for reducing this burden to Department of Defense, Washington Headquarters Services, Directorate for Information Operations and Reports (0704-0188), 1215 Jefferson Davis Highway, Suite 1204, Arlington, VA 22202-4302. Respondents should be aware that notwithstanding any other provision of law, no person shall be subject to a penalty for failing to comply with a collection of information if it does not display a currently valid OMB control number.</p> <p>PLEASE DO NOT RETURN YOUR FORM TO THE ABOVE ADDRESS.</p>				
1. REPORT DATE (DD-MM-YYYY)		2. REPORT TYPE Master's Thesis		3. DATES COVERED (From – To) Oct 2004 – Mar 2006
4. TITLE AND SUBTITLE UNDERSTANDING INNOVATION ADOPTION IN THE AIR FORCE			5a. CONTRACT NUMBER	
			5b. GRANT NUMBER	
			5c. PROGRAM ELEMENT NUMBER	
6. AUTHOR(S) Evans, Morgan J., Captain, USAF			5d. PROJECT NUMBER	
			5e. TASK NUMBER	
			5f. WORK UNIT NUMBER	
7. PERFORMING ORGANIZATION NAMES(S) AND ADDRESS(S) Air Force Institute of Technology Graduate School of Engineering and Management (AFIT/EN) 2950 Hobson Street, Building 642 WPAFB OH 45433-7765			8. PERFORMING ORGANIZATION REPORT NUMBER AFIT/GLM/ENS/06-05	
9. SPONSORING/MONITORING AGENCY NAME(S) AND ADDRESS(ES) HQAMC/A43 Attn: Col. Tonya M. Brickhouse 402 Scott Dr. Unit 2A2 Scott AFB IL 62225-5308 e-mail: tonya.brickhouse@scott.af.mil			10. SPONSOR/MONITOR'S ACRONYM(S)	
			11. SPONSOR/MONITOR'S REPORT NUMBER(S)	
12. DISTRIBUTION/AVAILABILITY STATEMENT APPROVED FOR PUBLIC RELEASE; DISTRIBUTION UNLIMITED.				
13. SUPPLEMENTARY NOTES				
14. ABSTRACT Innovation adoption has become a critical issue for organizations in both the public and private sectors. The search for competitive advantage has led to the recognition that innovation is a vital ingredient for an organization's survival and profitability in this information age. The United States Air Force is seeking to adapt to this new information age by transforming its business processes in order to sustain its competitive advantage as the world's most respected air force. Adopting innovations and integrating new or improved technologies, capabilities, concepts, and processes into Air Force planning and acquisition activities, organizations, and operations are goals of Air Force Transformation. Customer Relationship Management is one such innovation that organizations are pursuing to capture competitive advantage. CRM adoption and implementation successes and failures have been well-documented; however, organizational innovation adoption studies and CRM adoption studies in the United States Air Force—within the context of Innovation Diffusion Theory—could not be found. This research attempts to bridge this gap in the literature. Three innovation characteristics from Diffusion of Innovation Theory and three organizational characteristics, which were found to be significant antecedents to innovation adoption in prior studies, were used to develop innovation adoption hypotheses. These hypotheses were then tested using correlation analysis and multiple regression analysis. This research seeks to aid in increasing the understanding of the influences on CRM process innovation adoption within an Air Force organization.				
15. SUBJECT TERMS				
16. SECURITY CLASSIFICATION OF:			17. LIMITATION OF ABSTRACT	18. NUMBER OF PAGES
a. REPORT	b. ABSTRACT	c. THIS PAGE		
U	U	U	UU	107
			19a. NAME OF RESPONSIBLE PERSON Major Kirk A. Patterson email: kirk.patterson@afit.edu	
			19b. TELEPHONE NUMBER (Include area code) (937) 785-3636 x4653	