

Capacitive Sensors with Pre-calculable Capacitance

Stanislav Ďaďo

Faculty of Electrical Engineering, Czech Technical University in Prague, Department of measurement, Technická 2, 166 27 Praha 6, Czech Republic, e-mail: dado@fel.cvut.cz

Abstract — The advantages of capacitance techniques for measurement are well known and can be further enhanced by application of the design methods based on possibility to calculate their capacitance solely from electrode dimensions. The analytical calculation of capacitance is limited only to capacitors having cylindrical geometry of electrodes. Nevertheless by conformal mapping the majority of capacitive sensors can be designed. In this article besides the basic theory an example of sensor for measurement the angle of rotation is presented.

Keywords — Kelvin guard ring, capacitive sensors, analytical methods of capacitance calculation, Thompson-Lampard theorem

I. INTRODUCTION

The accuracy of capacitance calculations by analytical methods is much higher than one reached by the numerical methods based on the finite element approach (see example of fringe field of the sensor with circular electrodes and guard ring calculated by FEM in Fig. 2). The principle of the Kelvin guard ring capacitor (Fig. 1a) stimulated many works on generalization of this principle.

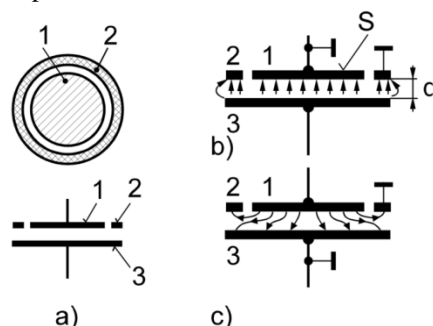

Fig. 1a). The principle of Kelvin guard ring capacitor and demonstration of independence of the capacitance on field homogeneity. The capacitance in cases b) and c) is equal

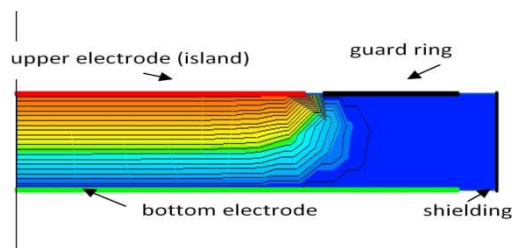

Fig. 2. Fringe field numerical model (FEM)

The capacitance between two electrodes i, j according Maxwell definition is given by equation

$$C_{ji} = \frac{Q_{ji}}{V_j - V_i} \quad (1)$$

where Q_{ji} is charge on electrode j induced by potential difference $V_j - V_i$ between electrodes. This means that for all other electrodes only their *presence and not their potential* contributes to the capacitance C_{ji} . Analytical calculation of the capacitance consists in solving of potential V distribution in the volume (space) in question (capacitor) following the surface charge density ρ calculations.

Potential V is related to charge density by *Poisson's equation*

$$\nabla^2 V = -\frac{\rho}{\epsilon_0} \quad (2)$$

In the charge-free region of the space and for cylindrical coordinates (r, φ, z) the Poisson equation transforms to Laplace equation (3),(4).

$$\nabla^2 V = 0 \quad (3)$$

$$\frac{\partial^2 V}{\partial r^2} + \frac{1}{r} \frac{\partial V}{\partial r} + \frac{1}{r^2} \frac{\partial^2 V}{\partial \varphi^2} = 0 \quad (4)$$

For the case, when the observed space and boundary conditions are rotation symmetrical, the potential V does not depend on the angle θ , leading to reduction of the *Laplace equation* into form

$$\frac{\partial^2 V}{\partial r^2} + \frac{1}{r} \frac{\partial V}{\partial r} + \frac{\partial^2 V}{\partial z^2} = 0 \quad (5)$$

By means of the variables separation method the potential V can be written as a sum of several products of r and z functions.

In general the solution has a form of sum of the *Bessel* and trigonometric functions. But the complete solution is possible only in a few cases – when section shape of the observed volume is simple and the *volume is surrounded by electrode boundaries with prescribed potential overlay*.

For instance, where one of three dimensions can be considered as infinite compared with two others, the Laplace equation becomes linear and two-dimensional. Several different electrode geometries can be solved analytically using the complex function theory and conformal mapping. This approach is used for e.g. in case of analytical calculations of the Thompson-Lampard primary standard of capacity [7].

One of the most important volume geometry is the cylinder with a rectangular section profile and rotational symmetric potential distribution on the boundaries (Fig. 3). In this case the Laplace equation is not linear but analytical solution is possible. Segment or ring electrodes overlapping or non-overlapping can be located on top or bottom surfaces (3 combinations) or as strips on inner and outer cylinder, or only on inner, or one electrode on inner and second on bottom surfaces (3 combinations).

The analytical calculation of the capacitance is feasible only if conducting surfaces lying beyond the electrodes are on ground potential, i.e. they form equivalent of guard rings. Five basic sensor archetypes can be derived from archetype of toroidal capacitor in Fig. 3.

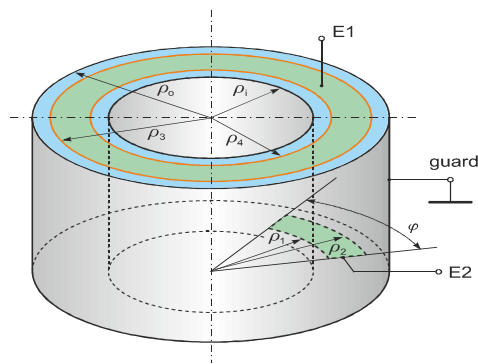

Fig.3. The archetype of the torus shaped capacitive sensor

For example for configuration, when the ring electrode E1 is located on the top surface and the sector electrode E2 lies on the bottom surface with all other parts of the torus acting as guard material following formula for capacitance is valid ($\rho_j = \pi r_j / d$):

$$C_1 = \frac{\epsilon_0 \epsilon_r 2\pi d}{\pi^2} \sum_{n=1}^{\infty} (-1)^n \left\{ \rho_2 W_n'(\rho_2, \rho_1) \times [\rho_1 W_n'(\rho_1, \rho_0) - \rho_2 W_n'(\rho_2, \rho_0)] - \rho_4 W_n'(\rho_4, \rho_0) \times [\rho_1 W_n'(\rho_1, \rho_1) - \rho_2 W_n'(\rho_2, \rho_1)] \right\} [W_n'(\rho_0, \rho_1)]^{-1} + \frac{1}{4} (\rho_2^2 - \rho_1^2) \quad (6)$$

The following short notations were used here:

$$W_n(x, y) = I_0(nx) K_0(ny) - K_0(nx) \quad (7)$$

and

$$W_n'(x, y) = \frac{1}{n} \frac{\partial}{\partial x} [W_n(x, y)] = I_1(nx) K_0(ny) + K_1(nx) I_0(ny) \quad (8)$$

The modified Bessel functions of the first and second kind and of zero and first order are denoted as $I_0(u), K_0(u)$.

The torus geometry of archetype converts to cylindrical when internal diameter

Using conformal mapping the cylindrical shape archetypes of sensors can be converted to planar equivalents.

For conformal mapping of cylinder in w -plane (Fig. 4.) to planar shape of the capacitor (Fig. 5.) in z -plane the transformation is as follows

$$z = \frac{1}{j} \ln \frac{1-W-1}{j w+1} \quad (9)$$

where

$$W = \rho e^{j\varphi} \text{ and } z = x + jy \quad (10)$$

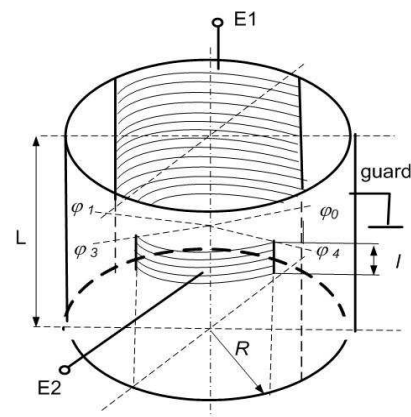

Fig. 4 Cylindrical sensor

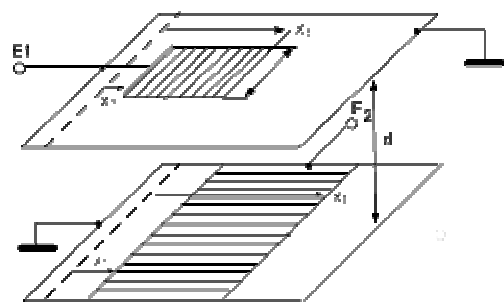

Fig. 5. Conformal mapping of the sensor in Fig. 4

The capacitance of the cylindrical sensor can be derived using formulas for archetype torus shaped capacitor. For parameters shown in Fig. 4 capacitance is given by the Eq. (11)

$$C = \frac{\epsilon_0 \epsilon_r}{\pi} l \ln \left\{ \frac{\sin((\theta_2 - \theta_0)/2) \sin((\theta_2 - \theta_1)/2)}{\sin((\theta_2 - \theta_0)/2) \sin((\theta_2 - \theta_1)/2)} \right\} \quad (11)$$

It is remarkable that of all dimensions of the sensor exclusively the length l of the shortest electrode, measured along the cylinder, determines the capacitance and neither the length L of the longest electrode nor the radius R of the tube.

The capacitance of the strip sensor (Fig. 5.) derived from the cylinder by mapping is then given by formally similar formula

$$C = \frac{\epsilon_0 \epsilon_r}{\pi} l \ln \left\{ \frac{\cosh(\pi(x_2 - x_0)/2d) \cosh(\pi(x_2 - x_1)/2d)}{\cosh(\pi(x_1 - x_0)/2d) \cosh(\pi(x_2 - x_1)/2d)} \right\} \quad (12)$$

II. CALCULATION OF CROSS CAPACITANCES

Typical example is calculation of the circular cross-capacitances for the capacitor derived from the basic shape of the Kelvin guard ring capacitor [7].

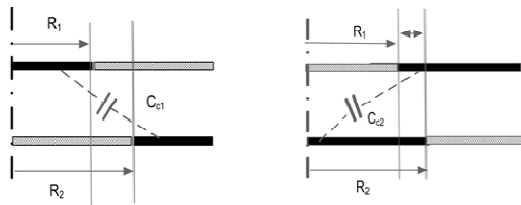

Fig. 6. Cross-capacitances of circular electrodes

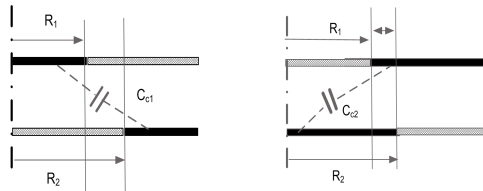

Fig. 7. Cross-capacitances of rectangular electrodes

The formulas for two possible cross-capacitances C_{C1} and C_{C2} (Fig. 6. and Fig. 7) were found analytically, and expressed by means of the first order modified Bessel functions I_1 and K_1 (13), (14).

$$C_{C1} = \frac{\epsilon_r \epsilon_0 (4\pi R_1 R_2)}{d} \sum_{n=1}^{\infty} (-1)^{n+1} I_1 \left(\frac{n\pi R_1}{d} \right) K_1 \left(\frac{n\pi R_2}{d} \right) \quad (13)$$

$$C_{C2} = C_{C1} + \frac{\epsilon_r \epsilon_0 \pi (R_2^2 - R_1^2)}{d} \quad (14)$$

It is important to notice that for $R_1 = R_2 = R$ equation (14) determines the capacitance of the circular version of Thompson-Lampard capacitor with the pre-calculable capacitance.

Interesting and for practice very useful fact is validity of the equations for C_{C1} and C_{C2} also for the cases when one electrode has the shape of a ring sector having angle Φ . Then factor π in equations

The basic equation valid for a circular capacitor can be modified for calculation of the capacitor capacitance having rectangular electrodes. Expanding the average radius R to infinity, leaving the length of the arc $l = \Phi R$ finite and replacing overlapping portion of the radii $R_2 - R_1$ by x , the capacitor with circular plates is transformed to the rectangular type lx (Fig.8). Mathematic reflection of these modifications yields to following relations for the cross-capacitances

$$C_{C1} = \epsilon_r \epsilon_0 \frac{l}{\pi} \left[\ln \left[2 \cosh \left(\frac{\pi x}{2d} \right) \right] - \frac{\pi x}{2d} \right] \quad (15)$$

$$C_{C2} = \epsilon_r \epsilon_0 \frac{l}{\pi} \left[\ln \left[2 \cosh \left(\frac{\pi x}{2d} \right) \right] + \frac{\pi x}{2d} \right] \quad (16)$$

And again for $x = 0$ it changes into the relation for the linear Thompson-Lampard primary standard capacitor whose capacitance is determined solely by the dimension l as follows from Eq. (17)

$$C_{C1} = C_{C2} = C_C = \epsilon_r \epsilon_0 \frac{l}{\pi} \ln 2 \quad (17)$$

Fulfilling the condition (18) guarantees the linear dependence of the capacitance on the change of the overlapping area caused by movement of electrodes, x , in horizontal plane.

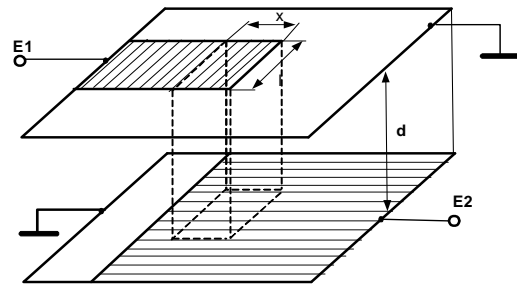

Fig. 8. Asymptotic expansion of the circular sector and ring capacitor

III. HEERENS'S RULES FOR DESIGN OF CAPACITOR WITH PRE-CALCULABLE CAPACITANCE

The founder of the theory of the capacitive sensors with the pre-calculable capacitance, W.Ch. Heerens, worked systematically on the development of rules and principles for design and construction of these kinds of sensors [3]. The most important rules come out from relations for the cross-capacitances, (18) and (19).

By simple analysis of the relation for C_{C2} it can be deduced, that this capacitance depends nearly linearly on the area of electrode overlapping lx when argument in the function cosh reaches high value, i.e. when

$$\frac{\pi x}{2d} \gg 1 \quad (18)$$

If this condition is fulfilled, then

$$2 \cosh \frac{\pi x}{2d} \cong e^{\frac{\pi x}{2d}} \quad (19)$$

and

$$\ln \frac{\pi x}{2d} = \frac{\pi x}{2d} \quad (20)$$

The capacitance C_{C2} then equals to

$$C_{C2} = \frac{\epsilon_0 \epsilon_r}{\pi} 1.2 \frac{\pi x}{2d} = \frac{\epsilon_0 \epsilon_r}{d} lx = C_{Cmin} \quad (21)$$

The capacitance, in accordance with the relation for the capacitance of planar electrodes placed in a homogenous field, is linearly proportional to the area lx of the electrodes overlapping.

The relative deviation from linearity, δ , can be defined as

$$\delta = \frac{C_{C2} - C_{Cmin}}{C_{Cmin}} = \frac{d}{\pi x} \ln \left[2 \cosh \left(\frac{\pi x}{2d} \right) \right] - \frac{1}{2} \quad (22)$$

The graph describing dependence of δ [%] on x/d is in Fig 9. a). It documents that linearity error is less than 1 ppm for $x/d > 5$ as it is given by Heerens rules.

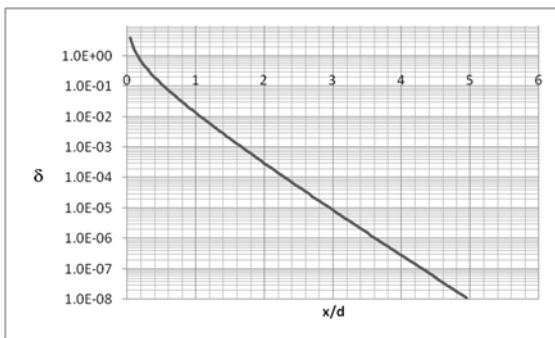

Fig. 9 a) Linearity error, single sensor

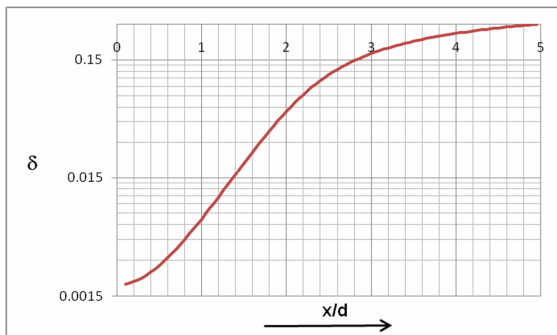

Fig. 9 b) Linearity error, differential sensor, $x_0=2d$

Similarly the capacity of the differential sensor in which stator electrodes overlap the moving rotor electrode by x_0 can be found.

As expected the differential configuration doubles sensor sensitivity and the ideal linear dependence of capacity $C(x)$ describes formula (23)

$$C_{lin} = \epsilon_r \epsilon_0 l \frac{2x}{d} \quad (23)$$

In case when condition (18) is not fulfilled, but the concept of capacitors with the pre-calculable capacitance is preserved, it is still possible to calculate capacitance

from active electrode dimensions. From the air gap distance d , given usually by mechanical or electrical restrictions, minimum value of the electrodes overlapping area lx_{min} and maximum allowable linearity error for the width e of planar electrode should be chosen according criterion (18).

The next essential design parameter is the geometry of guard electrodes – usually grounded. Their main role is to eliminate the effects of fringe field on the capacitance and to avoid any influence of electrically active bodies in the vicinity of the active electrodes. The relation (15) determining the cross-capacitance can provide this function.

In order to minimize the cross-capacitance C_{Cl} the first and the second term of Eq. (15) should be equal. In practice it means that the distance x between the edge of the active electrode and border of neighboring the conductive body should be chosen again according the condition (18): $\frac{\pi x}{2d} \gg 1$ (18)

The acceptable influence of the conducting bodies in the vicinity of the capacitor can be found from Eq. (22) following the concept of capacitors with the pre-calculable capacitance the volume, separating (guarding) capacitor from conductive surrounding plays role of the guard ring.

So the condition (18) and equation (22) can be used for the design of the width of guard electrodes.

On the basis of the previous analysis W.C. Heerens defined following *rules of thumb* for capacitor design with the pre-calculable capacitance:

- a) For the deviation from linearity (i.e. from theoretical formula) $d \leq 1$ ppm and precision of calculation of capacitance from dimensions using theoretical formula the minimum dimension causing the change of the overlapping area of planar electrodes must be $> 5d$, where d is the air gap distance between electrodes. Based on this rule the dimension of the active electrode can be chosen.
- b) The minimum guard area dimension g (e.g. width of guard ring) satisfying this inequality guarantees, that the relative deviation of accurate and calculated capacitance d will be less than 1 ppm ($g \geq 5$)
- c) The difference between the true and calculated capacitance will be less than 1 ppm, provided that the width of insulating gap s between active electrodes and guarding electrodes fulfills the condition $s < d/5$.
- d) The boundaries of active electrodes can be found in the center of these gaps
- e) The gap influence decreases according relation $\exp(-\pi d/s)$
- f) Fringe field influence decreases proportionally to $\exp(-\pi y/d)$.
- g) If two electrodes - which are situated on both opposite electrode carriers and which are forming together the properly guarded capacitor - have fringe field effect, accuracy of calculation better than 1 ppm is achieved if the sideways distance y between fringes is equal to $5d$.

IV. CAPACITIVE SENSOR OF THE ANGLE OF ROTATION (CSR)

An example of the sensor for the angle of rotation in horizontal plane is introduced. The sensor is based on the change of the area of electrodes overlapping and it could fulfill requirement of linearity of transfer characteristics for the angle of rotation measurement. To avoid the basic drawback of this configuration, i.e. influence of the air gap variation, and enhance sensitivity, the differential type of the sensor with multiple electrodes was used (Fig. 10.).

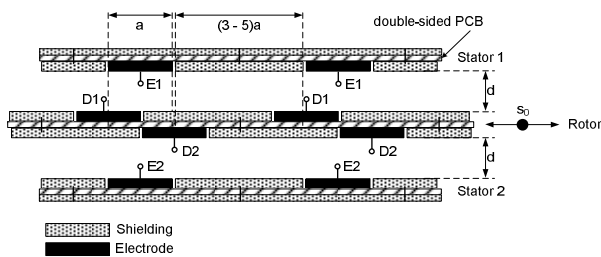

Fig.10. Front view (along the arrow) on vertically placed electrodes

Sensor is composed of three vertical – capacitor electrodes. Two of them, the bottom and the upper one, are fixed. The third, the middle one, is mounted on a seismic mass and can move within a small horizontal range between the others. This differential arrangement of the capacitive sensor makes the sensor independent on the vertical displacement of the middle electrode.



Fig. 11. Capacitive sensor of the angle of rotation

The outline of all electrodes is the same – sector of a circle. This shape is suitable for manufacturing technology on PCB. The electrodes are designed as angular rays going from the center of the circle made on each desk. The electrodes are connected by a bus at the inner periphery.

As illustrated in Fig. 10 electrodes on the stator are marked E1 and E2 and on the rotor D1 and D2. Desks are manufactured using printed circuit board (PCB) technology. On the rotor there are both sides used for electrodes with the same angle shift as the electrode width. The electrodes on the stator are the same and face to each other. All the other conductive parts are used as shielding and can be grounded.

In the ideal zero position the electrodes D1 and D2 of the rotor overlap in the middle of the stator electrodes E1 and E2. The move of the rotor causes the change ΔS of the overlapping area and consequently increases the capacitance of one couple and decreases the second one.

For the measurement of the angle of rotation the configuration, in which the electrodes E1 and E2 are joined, shielding parts of the stator are grounded and shielding parts of the rotor are left not connected.

Stator electrodes overlap half width of the rotor electrode at the initial position, s_0 . Using the differential sensor the horizontal movement shifts the rotor electrode by $\pm \Delta s$ from the s_0 . As it can be expected the differential sensor shows substantially better sensitivity (Fig. 9).

For the purpose of the angle of rotation sensing the linearity of the order 1 % appears to be satisfactory allowing the decrease of electrodes dimensions. From mechanical reason the air gap distance d cannot be substantially less than 1 mm. The full scale of the angle was chosen to be ± 2.5 mrad.

Based on the graph in Fig.9. for linearity error 1 % and full scale angle, corresponding to $\Delta s = 0.6$ mm (radius of the rotor segment $r = 500$ mm), the ratio $\Delta s/d = 0.6$. The angle width of the electrode $a = 5$ mrad and the guarding segment angle width $4a = 20$ mrad was chosen. Sensitivity is given by ENOB of the measuring circuit and reached the value of 170 fF.

V. MEASURING CIRCUIT- C/D CONVERTOR

For the proper function of CSR the elimination of parasitic capacitances of leads to electrodes is required. The simplest way is to use the circuit based on Fig. 12.

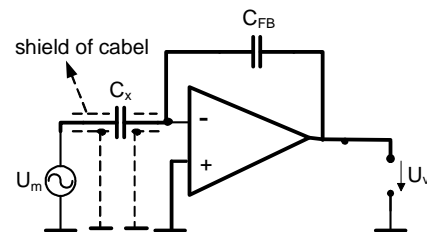

Fig. 12. Elimination of parasitic capacitances of leads.

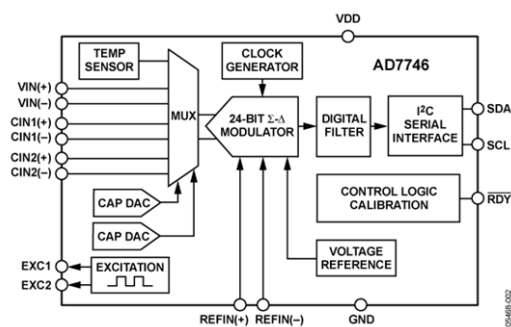

Fig. 13. Capacitance – to -Digital Converter AD 7746 by Analog Devices

Influence of capacitances of leads is eliminated as they are connected in parallel to an ideal voltage source or to a virtual ground of the operational amplifier.

Analog Devices offers sophisticated Capacitance-to-Digital Converter with up to 24-bit resolution, with input circuit connected as shown in Fig. 13. [1].

According to the AD7746 technical specification it permits independent single-ended measurement of the first or the second channel and also differential measurement.

VI. CONCLUSIONS

The typical configuration of sensors with the pre-calculable capacity is definition of potential overlay of all electrodes. Design of the capacitive sensors according the rules of the pre-calculable capacitance enables construction of an absolute sensor with capacity determined solely by dimensions of electrodes. In practice it brings welcomed and important property of avoiding the influence of all objects in the vicinity of the sensor.

Yet another advantageous property is the possibility to calculate capacity from the formulas for "ideal" capacitor with homogenous field with accuracy predicted from dimensions of "the guarding elements" (Heerens rules). This fact allows determination of transfer function between measured quantity and capacitance and eventually to calculate e.g. the deviation from the ideal function.

REFERENCES

- [1] AD7745/AD7746 (2005), 24-Bit Capacitance-to-Digital Converter with Temperature Sensor, Datasheet, Analog Devices, Rev.0, Online: http://www.analog.com/static/imported-files/data_sheets/AD7745_7746.pdf (as of May, 2010)
- [2] Heerens W.C., "Application of capacitance techniques in sensor design", *J. Phys.E:Sci.Instrum.,London*, Vol. 19, pp. 897-906
- [3] Heerens W.C., "Basic principles in designing highly reliable multi-terminal capacitor sensors and performance of some laboratory test models", *Sensors and Actuators A*, Vol. 3, pp. 137-48, 1983
- [4] Heerens W.C., "Multi-terminal capacitor sensors", *J. Phys.E:Sci.Instrum. London*, Vol. 15, No. 1, pp. 137-4, 1982,
- [5] Heerens W.C., "The solution of Laplace's equation in cylindrical and toroidal configurations with rectangular sectional shapes and rotation – symmetrical boundary conditions", *Journal of Applied Physics, London*, Vol.47, No. 8, pp. 3740-44, 1976
- [6] Strunc J., Buben J., Dado S., "Rotation Component of Seismic Signal"; *Poster, EGU 2nd General Assembly, Vienna, Austria, SM1-1TU2P-0037*, 2005
- [7] Dado S., Kreidl M., "Senzory a měřicí obvody", *Vydavatelství ČVUT, Praha, 1996 (in Czech)*
- [8] Bohacek J. (1994), "Metrologie elektrických veličin", *Monography, CVUT, Praha. ISBN 80-01-01152-6 (in Czech)*
- [9] Strunc J., "Rotational Seismometer on the Capacitive Principle", *Doctoral Thesis, Faculty of Electrical engineering, CTU, Prague, July 2010. Tutor of Thesis: Dado S.*