

HYBRID GENETIC ALGORITHM TO THE SYNTHESIS OF OPTIMAL HEAT EXCHANGER NETWORKS

M. A. S. S. Ravagnani^a,

A. P. Silva^a,

and A. A. Constantino^b

Universidade Estadual de Maringá

^aDepartamento de Engenharia Química

^bDepartamento de Informática

Av. Colombo 5790

CEP 87020-900, Maringá, Paraná, Brasil

ravag@deq.uem.br

ABSTRACT

In this paper a new systematic is proposed, interfacing Pinch Analysis and Genetic Algorithms (GA). Initially the optimal ΔT_{\min} is found by using a genetic algorithm. In a second step, with the optimal ΔT_{\min} , the pinch point is obtained, and the problem is divided in two regions, below and above it. The optimal HEN is obtained for each side of the pinch and the final HEN is achieved. An example from the literature was solved using the proposed systematic. Results show the applicability of the proposed methodology, obtaining a cost value lower than those presented in the literature.

Keywords: Pinch Analysis, Genetic Algorithms, heat exchanger networks

NOMENCLATURE

a, b, c	cost function constants that depend on the type of equipment used
A_{\min}	minimum heat transfer area, m ²
C_{capital}	capital cost, \$/year
C_{CU}	cold utility cost, \$/kW/year
C_{energy}	energy cost, \$/year
C_{global}	global cost, \$/year
C_{HU}	hot utility cost, \$/kW/year
CU	cold utility consumption, kW
CU_{\min}	cold utilities minimum demand
f	factor multiplicative of ΔT_{\min} to relaxe the constrain
h	individual heat transfer coefficient
HU	hot utility consumption, kW
HU_{\min}	hot utilities minimum demand
i	interest rate
N	number of streams, including hot and cold utilities
Q	heat exchanged
q	heat
t	plant life time, years
$T_{c_{in}}$	inlet cold stream temperature
$T_{c_{out}}$	outlet cold stream temperature
$T_{h_{in}}$	inlet hot stream temperature
$T_{c_{out}}$	outlet hot stream temperature
U	global heat transfer coefficient
U_{\min}	minimum number of heat transfer equipment

Greek symbols

ΔT_{LM}	logarithm mean temperature difference
ΔT_{\min}	minimum approach temperature

Subscripts

i	streams
j	intervals
k	equipment

INTRODUCTION

Excessive energy consumption by using hot and cold utilities influences hardly the global cost of industrial processes. For this reason, one of the designer major worries has been the reduction of utilities consumption, as well as the reduction of fixed cost in the equipment.

Most of the papers published in the area presents Pinch Analysis and Mathematical Programming, using integer linear and non-linear programming as alternatives to solve the heat exchangers network synthesis problem. Some important published papers are Linnhoff et al. (1982), Linnhoff and Hindmarsh (1983), Linnhoff (1993), Linnhoff (1994) and Ravagnani et al. (2003), using Pinch Analysis and Papoulias and Grossmann (1983) and Floudas et al. (1996), using Mathematical Programming.

Recently, some heuristic methods of optimization have been used in heat exchanger networks synthesis.

In the present paper, a systematic procedure

was developed, using Genetic Algorithms together with Pinch Analysis concepts, to the optimal heat exchanger network synthesis, with minimum global cost.

MATERIAL AND METHODS

Genetic Algorithms are relatively recent methods. They do not use any information of derivate, and because of this, they present good chances of escape from local minimum. Their application in practical problems generally brings to global optimal, or, at least, to solutions more satisfactory than those ones obtained by other methods.

Genetic Algorithms use a direct analogy of the evolution phenomena in nature, in such a way that each individual represents a possible solution to a given problem. The individuals are randomly determined from the search space. The 'fitness' of the solutions, which is the result of the variable that is to be optimized, is determined subsequently from the fitness function. The individual that generates the best fitness within the population has the highest chance to return in the next *generation*, with the opportunity to reproduce by cross over, with another individual, producing decedents with both characteristics. If a genetic algorithm is developed correctly, the population (group of possible solutions) will converge to an optimal solution for the proposed problem. The processes that have more contribution to the evolution are the crossover, based in the selection and reproduction and the mutation.

Genetic Algorithms are different from the traditional methods of search and optimization, especially because they work with a codification of the group of parameters and not with the parameters, and they use a population, and not just a point.

Besides genetic operators, it is also important to analyze the influence of some parameters in the behavior and in the performance of the genetic algorithm, to establish them according to the problem necessities and the available resources. The influence of each parameter in the algorithm performance depends on the class of problems that is being treated. Thus, the determination of an optimized group of values to these parameters will depend on a great number of experiments and tests.

The main genetic parameters are the size of the population that affects the global performance and the efficiency of the genetic algorithm, the mutation rate that avoids that a given position remains stationary in a value, or that the search

becomes essentially random.

Some important papers were published in industrial applications, like Castell et al. (1998), Wang et al. (1998), Hugget et al. (1999), Yuen et al. (2000), Nougués et al. (2002), Stephan and Chase (2003) and recently, specifically in heat exchanger networks synthesis, Ravagnani et al. (2005).

Some steps compose the systematic procedure developed in this paper.

In the first step of the developed methodology, optimal DT_{min} is found by using a Genetic Algorithm. The function global cost is obtained by summing the annual cost of energy and the capital cost. In this stage, the heat exchangers network is not yet synthesized. In this way, the heat transfer area to be used in the cost function is the minimum possible heat transfer area, to the network to be synthesized. This area is found, after the DT_{min} optimization, to a group of heat and cold streams by plotting the composite curves in a diagram Temperature \times Enthalpy (TH). For each DT_{min} fixed, a different value for A_{min} and for hot and cold utilities are found. Consequently, for the function global cost, which depends on these variables, different values will be obtained.

In a second step, pinch point is found and the problem is divided in two different regions, above and below it. Optimal heat exchanger networks are synthesized by using another Genetic Algorithm.

Finally, the optimal heat exchanger network is achieved combining both sub-networks previously synthesized.

The systematic procedure was tested with a case from the literature. Results showed the efficiency of the developed methodology during the DT_{min} optimization as well as in the achievement of the optimal configuration of the heat exchanger network.

PROBLEM FORMULATION

Genetic Algorithms are based in the species natural selection and evolution, mainly considering the more apt individuals surviving. The individuals that present better adjustment (better value of the objective function) show higher probabilities of crossover and to transmit to the next generation their well succeeded genes. Nevertheless, all the individuals, apt or not, can be mutated from time to time. In this way, Genetic Algorithms are relatively recent optimization methods and no

information about derivatives are needed. In such a way, they present good chances of escaping from local optimum.

There are no guarantees about their convergence. However, when applied in practical problems, generally the global optimum is found, or, at least, for more satisfactory solutions than those one obtained by another methods.

ΔT_{\min} Optimization

In this stage, Eq. (1), proposed by Townsend and Linnhoff (1984), is used:

$$A_{\min} = \sum_j^{\text{intervals}} \frac{1}{\Delta T_{LMj}} \cdot \left(\sum_i^{\text{streams}} \frac{q_i}{h_i} \right)_j \quad (1)$$

where: j represents enthalpy intervals and i the processes streams, in a TH diagram, to the composite curves, divided in enthalpy intervals; ΔT_{LM} represents the logarithm mean temperature difference to the streams i in the interval j ; q_i and h_i are the available or necessary heat amount and the individual convection heat transfer coefficient, respectively.

For each ΔT_{\min} , a different value of A_{\min} is found and different hot and cold utilities demands are obtained. Consequently, the global cost function that depends on these variables will have different values.

The annual energy, capital and global cost are described in Eqs. (2), (3) and (4), respectively.

$$C_{\text{Energy}} = C_{HU} \cdot HU + C_{CU} \cdot CU \quad (2)$$

$$C_{\text{Capital}} = \left(a + b \cdot A_{\min}^c \right) \frac{(1+i)^t}{t} \quad (3)$$

$$C_{\text{Global}} = C_{\text{Energy}} + C_{\text{Capital}} \quad (4)$$

where: a is the hot utility cost, in \$/kW/year; b is the cold utility cost, in \$/kW/yeas; HU is the hot utility consumption, in kW; CU is the cold utility consumption, in kW; a , b and c are constants and depend on the equipment type used; i is the interest rate; t is the plant life time, in years; are given in \$/year.

As mentioned above, A_{\min} depends on ΔT_{\min} . In this way, optimal ΔT_{\min} is found by

minimizing Eq. (4). This minimum value represents the minimum heat exchanger network cost. This is, therefore, the objective function to be minimized in the first step of this work. The non-linear function is optimized by using a Genetic Algorithm.

The genetic operators used in this stage are initialization, aptitude calculus, crossover, mutation and selection. The two parents that will generate a child are chosen by the roulette method of selection. Each parent individual is represented in the roulette proportionally to its aptitude. In this way, a greater portion in the roulette is given to the individuals with high aptitude. To the individuals with low aptitude a small portion in the roulette is given. Finally, the roulette is rotated and the parents are drawn.

Mathematically, the probability of selection of an individual is calculated as the ratio between the individual aptitude and the sum of all the aptitudes. Based in this value, it can be determined the draw range favorable to that individual. In such a way, any random number drawn between 0 and 1 can be associated to one individual.

During the mutation step not all children are selected. To know if a child will mutate or not, a random number is generated to each child. If this number is less or equal to the mutation rate, this child will mutate. If not, it will not mutate.

Heat Exchanger Network Synthesis

The heat exchanger network synthesis task consists in finding matches between hot and cold streams, hot streams and cold utilities and cold streams and hot utilities. The set of all equipment used in these matches is the heat exchanger network.

However, finding viable combinations without violating the Second Law of Thermodynamics and being also economically viable is not an easy task. As the number of streams is increased, the number of probable combinations is also increased. In this way, heat exchanger network synthesis is not viable without computers.

The global cost of a heat exchanger network, as shown in Eq. (5), depends on the hot and utilities cost and on the capital cost, related to the heat exchanger area. The minor utilities consumption will be achieved if respected minimum hot and cold utilities demands, found by using Pinch Analysis concepts, to a determined ΔT_{\min} .

Minimum capital cost will be achieved by finding the streams combination that uses heat exchanger equipment (heat exchangers, coolers and heaters) with the smallest heat exchange area. The optimal heat exchanger network presents the minor global cost. Some constraints must be satisfied.

These constraints are shown below. Heat must be transferred from a hot to a cold stream. Hot stream must have temperatures greater than cold stream, as shown in Eq. (6). The minimum number of heat transfer equipment must be found, in each sub-network, as in Eq. (9).

Subject to:

$$\begin{cases} (Th_{in})_k > (Tc_{out})_k \\ (Th_{out})_k > (Tc_{in})_k \end{cases} \quad (6)$$

$k = 1, \dots, \text{number of equipment}$

$$\begin{cases} |(Th_{in})_k - (Tc_{out})_k| \geq f \cdot \Delta T_{min} \\ |(Th_{out})_k - (Tc_{in})_k| \geq f \cdot \Delta T_{min} \end{cases} \quad (7)$$

$k = 1, \dots, \text{number of equipment}$

$$\begin{cases} HU \leq HU_{min} \\ CU \leq CU_{min} \end{cases} \quad (8)$$

$$U_{min} = N - 1 \quad (9)$$

where: C_{HU} , C_{CU} , HU , CU , i , t , a , b and c are known; k represents equipment; A is the heat exchanger area for each equipment; Th_{in} and Tc_{out} are inlet and outlet hot stream temperatures; Tc_{in} and Tc_{out} are inlet and outlet cold stream temperatures; f is a factor multiplicative of ΔT_{min} to relax the constrain; HU_{min} and CU_{min} are hot and cold utilities minimum demand; U_{min} is the minimum number of heat transfer equipment; N is the number of streams, including hot and cold utilities.

Heat transfer area is found by Eq. (10) for each equipment present in the network. In this equation, Q is the heat exchanged, U is the global heat transfer coefficient and ΔT_{LM} is the logarithm mean temperature difference.

$$A \mid \frac{Q}{U \Delta T_{LM}} \quad (10)$$

Eqs. (6) and (7) were presented separately to emphasize the existence of thermodynamic restrictions and ΔT_{min} . However, they can be combined, as in Eq. (11).

$$\begin{aligned} & /Th_{in} C_k \ 4 /Tc_{out} C_k \ \Delta T_{min} \\ & /Th_{out} Q_k \ 4 /Tc_{in} Q_k \ \Delta T_{min} \end{aligned} \quad (11)$$

$k \mid 1, \dots, \text{number of equipment}$

Genetic operators used in this stage are the same used in the previous section, however, adapted to the new problem.

CASE STUDY

To test the methodology developed, a case was studied. The problem was presented in Ahmad (1985) and has 10 process streams (6 hot and 4 cold), a hot utility stream (steam) and a cold utility stream (cold water).

The value of ΔT_{min} proposed by Ahmad (1985) was 10°C , and this value was not optimized previously. Streams data and cost equation parameters are presented in Tab. 1. Eq. (12) presents the equation, where C is in \$ and A in m^2 .

$$C \mid 60 \sqrt{A} \quad (12)$$

The value of ΔT_{min} was optimized and Fig. 1 shows capital, energy and global cost functions. It was necessary 57 generations to find the optimum value of 24°C for ΔT_{min} . The population was set to 50 individuals and the mutation rate was 40%. The heat exchangers network was synthesized using the same 24°C for ΔT_{min} . The problem was divided into two sub-problems, below and above the pinch, and maximum energy recovery was found by using Pinch Analysis. In this case, the heat exchanger synthesized has the minimum energy and capital costs. The heat exchangers network synthesized is presented in Fig. 2.

Table 1. Streams data and cost parameters.

Stream	Type	T _{in} (°C)	T _{out} (°C)	CP (kW/°C)	h (kW/m ² /°C)
H1	Hot	85	45	156.3	0.05
H2	Hot	120	40	50.0	0.05
H3	Hot	125	35	23.9	0.05
H4	Hot	56	46	1,250.0	0.05
H5	Hot	90	85	1,500.0	0.05
H6	Hot	225	74	50.0	0.05
C1	Cold	40	55	466.7	0.05
C2	Cold	55	65	600.0	0.05
C3	Cold	65	165	195.0	0.05
C4	Cold	10	170	81.3	0.05
Steam	Hot utility	200	199	--	0.05
Water	Cold utility	15	25	--	0.05

Steam cost: 100 \$/kW/year
Water cost: 15 \$/kW/year

A	b	c	i	t
0	300	1	0	5

Figure 1. ΔT_{\min} Optimization

Table 2 presents results comparison. It was necessary 8 generations to find the minimum value of the objective function, and the minimum cost obtained is 5.673 M\$/year. The heat transfer area is 56,600.56 m². The population was set to 20 individuals and the mutation rate was between 10%-80%. Cost data are the same used in previous section. Relaxation value for ΔT_{\min} was 0.71.

CONCLUSIONS

In most papers published in the literature, the ΔT_{\min} optimization step is neglected.

In general, an arbitrary value is used to the heat exchanger synthesis. Nevertheless, if an inadequate value is chosen, bad solutions from the point of view of utilities consumption and capital cost will be achieved.

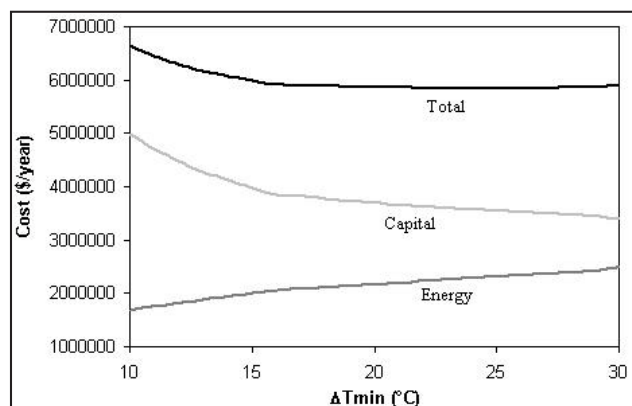
The proposed methodology, using Genetic Algorithms, is efficient to find optimal ΔT_{\min} values as well as optimal heat exchanger networks configurations, being easy to use.

The utilization of algorithms developed based on the application of Pinch Analysis to identify the pinch point and the minimum energy demand and the minimum number of equipment allows the user to find fast and automatically the best possible alternatives. Besides, these algorithms are versatile, being adaptable to several kinds of problems by modifying or including the set of hypothesis and considerations.

To the case studied, the value used in Ahmad (1985) to the ΔT_{\min} is very different than the optimized value. In the case studied, the value proposed by Ahmad (1985) was 10°C. Using the procedure developed for the ΔT_{\min} optimization, the value found was 24°C. For the ΔT_{\min} proposed in literature, Ahmad (1985), the values for the HEN are very different, as can be seen in Tab. 4. The minimum global cost is achieved for ΔT_{\min} of 24°C. Although the energy cost is greater than the presented in the literature, the capital cost is minor. Because of that, the global annual cost is minimum, as compared to literature.

Finally, one can conclude that the proposed systematic is efficient in the first step of the design, ΔT_{\min} optimization, as well as in the optimal heat exchangers network synthesis.

Table 2. Results comparison

	Ahmad (1985)	Present paper
Hot utility (kW)	15,400	20,529.3
Cold utility (kW)	9,796	14,923.8
Total area (m ²)	--*	56,600.56
Energy cost (\$/year)	1,686,940	2,276,787
Capital cost (\$/year)	5,387,060	3,396,034
Total cost (\$/year)	7,074,000	5,672,821

(*) Not supplied in the reference

REFERENCES

AHMAD, S., 1985, Heat exchanger networks: cost tradeoffs in energy and capital, Doctoral Thesis, Faculty of Technology, University of Manchester Institute of Science and Technology, Manchester, UK.

Castell, C. M. L., Lakshmanan, R., Skilling, J. M., 1998, Optimization of Process Plant Layout

Using Genetic Algorithm. *Computers and Chemical Engineering*, Vol. 22, pp. S993 – S996.

Floudas, C. A., Ciric A. R., and Grossmann, I. E., 1986, Automatic Synthesis of Optimum Heat Exchanger Network Configurations, *AIChE Journal*, Vol. 32, No. 2, pp. 276 – 290.

Hugget, A.; Sebastian, P. and Nadeau, J. P., 1999, Global Optimization of a Dryer by Using Neural Networks and Genetic Algorithms. *AIChE Journal*, Vol. 45, No. 6, pp. 1227 – 1238.

Linnhoff, B., 1994, Use *Pinch* Analysis to knock down Capital Cost and Emissions, *Chemical Engineering Progress*, Aug., pp. 32–57.

Linnhoff, B., 1993, Pinch Analysis: A state-of-art Overview, *Transactions of the IChemE*, Vol. 71, Part A, pp. 503–522.

Linnhoff, B., Hindmarsh, E., 1983, The *Pinch* Design Method for Heat Exchanger Networks. *Computers and Chemical Engineering*, Vol. 38, No. 5, pp. 745–763.

Linnhoff, B., Townsend, D. W., Boland, D., Hewitt, G. F., Thomas, B. E. A., Guy, A. R., Marsland, R. H., A, 1982, User Guide on Process Integration for the Efficient Use of Energy, The Institute Of Chemical Engineers, U.K.

Nougués, J. M., Grau, M. D., Puigjaner, L. 2002, Parameter Estimation with Genetic Algorithm in Control of Fed-Batch Reactors. *Chemical Engineering and Processing*, Vol. 41, pp. 303–309.

Papoulias, S. A., Grossmann, I. E. A., 1983, Structural Optimization Approach in Process Synthesis – II: Heat Recovery Networks, *Computers and Chemical Engineering*, Vol. 7, No. 6, pp. 707–721.

Ravagnani, M. A. S. S., Silva, A. P., Andrade, A. L., 2003, Detailed Equipment Design in Heat Exchanger Networks Synthesis and Optimization, *Applied Thermal Analysis*, Vol. 23, pp. 141– 51.

Ravagnani, M. A. S. S., Silva, A. P., Arroyo, P. A., Constantino, A. A., 2005, Heat Exchanger Network Synthesis and Optimization Using Genetic Algorithm, *Applied Thermal Analysis*, Vol. 25, pp. 1003–1017.

Stephan, E. A. and Chase, G. G., 2003, Use of Genetic Algorithms as an Aid in Modeling Deep Bed Filtration. *Computers and Chemical Engineering*, Vol. 27, pp. 281–292.

Wang, K., Qian, Y., Yuan, Y., 1998,

Synthesis and Optimization of Heat Integrated Distillation Systems Using an Improved Genetic Algorithm. *Computers and Chemical Engineering*, Vol. 23, pp. 125–36.

Yuen, C. C.; Aatmeeyata; Gupta, S. K. *et al.*, 2000, Multi-objective optimization of membrane separation modules using genetic algorithm. *Journal of Membrane Science*, Vol. 176, pp. 177–196.

APPENDIX

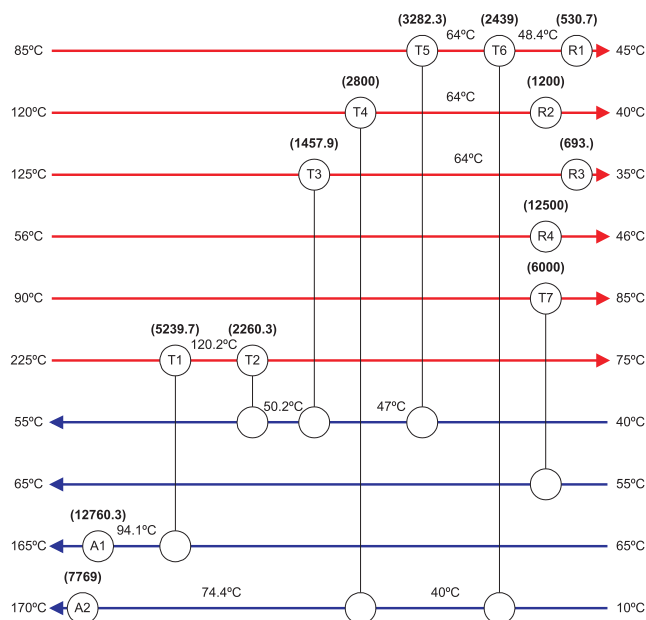

Figure 2. Final heat exchanger network.