

# A PARAMETRIC STUDY AND PERFORMANCE EVALUATION OF DC ELECTROMAGNETIC PUMPS WITH BEMC-1 CODE

E. M. Borges<sup>a</sup>,

F. A. Braz Filho<sup>b</sup>,

and L. N. F. Guimarães<sup>c</sup>

Centro Técnico Aeroespacial – CTA  
Instituto de Estudos Avançados – IEAv  
Divisão de Energia Nuclear – ENU  
CP. 6044, CEP. 12231-970  
São José dos Campos, São Paulo, Brazil

<sup>a</sup>eduardo@ieav.cta.br

<sup>b</sup>fbraz@ieav.cta.br

<sup>c</sup>guimarae@ieav.cta.br

## ABSTRACT

Electromagnetic pumps are used to control liquid metal fluid flow in cooling loops. The principle of operation of an electromagnetic pump is based on Lorentz's force. This is obtained by interaction of the magnetic field and the electrical current, imposed and adjusted by independent external electric power sources. In this work are presented the continuous current electromagnetic pumps, their basic equations and the BEMC-1 code, developed for design and performance evaluation of a DC electromagnetic pump. The main objective of this paper is a parametric study for magnetic induction, static pressure, fluid flow and performance evaluation of the pump. The theoretical results are compared with the experimental data to get adjust factors to be used in the BEMC-1 code. In this way the BEMC-1 code can be validated and used in the evaluations and projects of DC electromagnetic pumps.

**Keywords:** electromagnetic pump, fluid flow control, liquid metal, computational simulation, experimental evaluation.

## NOMENCLATURE

a	channel height, m
b	channel width, m
B	magnetic field, Wb/m <sup>2</sup> or T
c	useful length, m
d	iron-break, m
E <sub>c</sub>	electro-countermove force, V
f <sub>cor</sub>	correction factor
F	force, N
I	main electric current, A
I <sub>field</sub>	field current, A
N	number of spires
P	pressure, N/m <sup>2</sup> or cm Hg
R	electric resistance, Ohm
V	electric tension, V
W	volumetric flow rate, l/s

## Greek symbols

ΔL	static pressure, cm Hg
μ	Magnetic permeability, Wb/(Am)

## Subscripts

b	bypass
cor	corrects
e	useful
exp	experimental
t	total
teo	theoretical
w	wall

## INTRODUCTION

In the Institute of Advanced Studies (IEAv), was developed, successfully, the first two continuous current electromagnetic pumps (DC EM pumps) of Brazil. The first was built with C-type magnet and coils; and the second, with Samarium-Cobalt permanent magnets, for magnetic field generation (Borges et al., 1995 and Borges et al., 1996). Both were tested and performed quite satisfactory. Experiments were run for measurements of magnetic field, static pressure and dynamic operation. The last two experiments were done, with mercury, in closed loops, especially developed for these purposes.

The electromagnetic pumps do not have movable parts, are completely stamped, present high reliability and allow the flow control of liquid metals. These characteristics make them interesting to be used in fast nuclear reactors cooled with liquid metal, as in EBR-II (Lentz et al., 1985), PRISM (Kwant et al., 1988) and REARA (Prati et al., 1994), these are experimental reactors refrigerated with liquid sodium. As well as, in space nuclear reactors cooled by liquid lithium, as in the SP-100 project (Atwell et al., 1989 and Armijo et al., 1989).

The BEMC-1 code (Borges et al., 2003) was elaborated to study each stage of the development of a DC electromagnetic pump and to produce its performance evaluation. This code is quite versatile and it facilitates the evaluation of deviations between calculated and experimental data. It also allows the use of correction factors, in way to minimize those observed differences and it can latter be used in a design of a DC electromagnetic pump.

This work presents the DC electromagnetic pumps, their basic equations, the BEMC-1 code, a parametric study comparing theoretical and experimental data of magnetic field, static pressure and dynamic operation, for some magnetic field and main current values, and the curves of performance evaluation of a DC electromagnetic pump.

**ELECTROMAGNETIC PUMPS**

In a DC electromagnetic pump the Lorentz’s force defines the intensity and the direction of the force applied in the conductive fluid under influence of the main electric current and of the magnetic field imposed. The magnetic field and the main electric current can be controlled by two independent electric power sources.

Figure 1 shows the principle of operation of DC electromagnetic pump, where *a* is the channel height of the pump, *m*; *b* is the channel width, *m*; and *c* is the useful length, *m*.

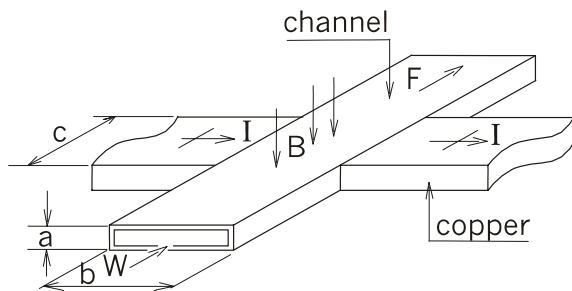

Figure 1. Principle of operation of DC electromagnetic pump.

**Theory**

Borges (1991) shows the theory to design, develop, and performance evaluation of DC electromagnetic pumps.

The magnetic field can be calculated with the Ampere’s Law:

$$B = \mu N I_{\text{field}} / d \tag{1}$$

where, *B* is the magnetic induction field intensity, *Wb/m<sup>2</sup>* or Tesla; *μ* is the Magnetic permeability, *Wb/(Am)*; *N* is the spire total number of the coils; *I<sub>field</sub>* is the magnetic field current supplied, *A*; and *d* is the iron-break or air gap length, *m*.

The Eq. (1) is correct because the magnetic loss in the iron-break is greater than the one in the magnet, and the magnetic permeability to a liquid metal is the same to the one of the vacuum.

Considering the magnetic field perpendicular to the main electric current and the direction of the fluid flow, the force resulting from the interaction between magnetic field and main electric current is:

$$F = B I_c b \tag{2}$$

where, *F* is the force, *N*; and *I<sub>c</sub>* is the useful electric current, *A*.

The head pump can be defined by:

$$P = F / (ab) \tag{3}$$

substituting the Eq. (2) in the Eq. (3) comes to:

$$P = B I_c / a \tag{4}$$

where, *P* is the pressure, *N/m<sup>2</sup>*, or

$$P = B I_c / (1360 a) \tag{5}$$

where, *P* is the pressure, *cm Hg*.

Figure 2 presents the equivalent electric circuit of the DC electromagnetic pump.

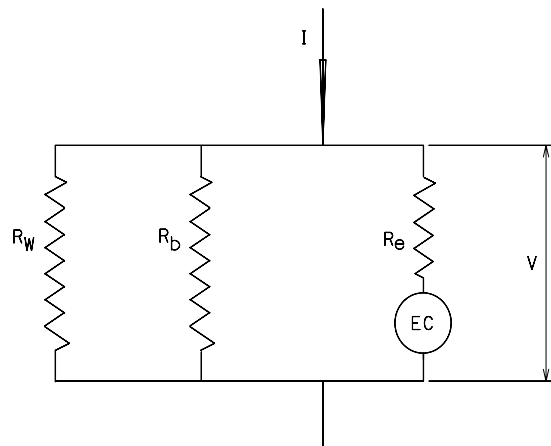

Figure 2. Equivalent electric circuit of DC EM pump.

Electric tension of the electromagnetic pump can be calculated by:

$$V = I_c R_e + E_c = I R_t \tag{6}$$

where, *V* is the electric tension, *V*; *R<sub>e</sub>* is the useful electric resistance (of the fluid in the channel), *Ohm*; *R<sub>t</sub>* is the equivalent electric resistance of the circuit, *Ohm*; *I* is the main current, *A*; and *E<sub>c</sub>* is the electrocountermove force resulting of the fluid moving in the magnetic field, *V*. This induced voltage can be obtained by Eq. (7):

$$E_c = B W / a \tag{7}$$

where, *W* is the volumetric fluid flow rate, *l/s*.

The useful electric current can be calculated by Eq. (8):

$$I_c = \frac{I}{1 + R_e \left( \frac{R_w + R_b}{R_w R_b} \right)} - \frac{E_c}{R_e + \frac{R_w R_b}{R_w + R_b}} \tag{8}$$

where,  $R_b$  is the electric resistance of the bypass or escape, Ohm. This is related with the geometry of the pump, and it is calculated multiplying the useful electric resistance by an empiric correction factor (Watt, 1958). The useful electric current is a function of the volumetric fluid flow. In the static pressure case (without fluid flow) the last term of the Eq. (8) is null. And in the dynamic pressure case (with fluid flow) this term is not null.

### BEMC-1 Code

The fundamental stages of the design of an electromagnetic pump are the evaluation of magnetic field, static pressure and dynamic fluid flow data.

The BEMC-1 code was developed in C++ language. It was created with the objective to evaluate each stage of the development of a DC electromagnetic pump. With this code it is possible to change all the important parameters of the pump.

The pumped fluid properties, as well as the geometry and materials of the channel data, are used to calculate the electric resistances. These parameters are used in the Eq. (6) and Eq. (8).

A very important parameter is the magnetic field. This can be calculated by Eq. (1), in function of the air gap length and of the magnetic field current. If necessary the code allows that the magnetic field to be corrected by an appropriate correction factor.

The head pump, calculated by Eq. (4) and Eq. (5), depends on the magnetic field, the duct geometry and the useful electric current. The last one is a function of the main current, the electric resistances and the volumetric fluid flow rate, in the Eq. (7) and Eq. (8).

The static pressure is the operational limit of the pump. It is calculated without the last term of Eq. (8), because this is null.

The dynamic pressure is the head pump to fluid flow. In this case the useful electric current must be calculated with the last term of Eq. (8). Because in this case: electro-countermove force, obtained in Eq (7), is not null.

The BEMC-1 program can evaluate the fluid flow and the head pump operating in closed circuits, calculating the pressure loss of the loop, as a function of the volumetric fluid flow rate, the channel diameter and the equivalent length of the loop.

The BEMC-1 code allows the project and the optimization of a DC electromagnetic pump, by changing data and parameters to analyze a new condition of performance of the pump, as well as, geometric data of the pump and of the loop.

## PARAMETRIC STUDY

Two DC electromagnetic pumps are studied, one, has steel-1020 C-type magnet and field coils with 2000 spires and air gap length with 20 mm, and the other uses Samarium-Cobalt permanent magnets under channel to generate the magnetic field.

The experimental and theoretical data of magnetic field, pressure and flow pump are compared for definition of the best correction and adjustment factors of the BEMC-1 code.

In this parametric study, corrections are applied to the magnetic field in function of the field current, as well as, of the pressure values and volumetric fluid flow rate supplied by the EM pump, in function of the main electric current.

### Magnetic Field

An electric power source of continuous current HP-6030A supplies the magnetic field current of the C-type pump. There are 2000 spires to get magnetic field in air gap. Figure 3 shows data of theoretical magnetic field, calculated by BEMC-1, with Eq. (1), and the average experimental magnetic field data, in the center of the air gap, as a function of the magnetic field current supplied.

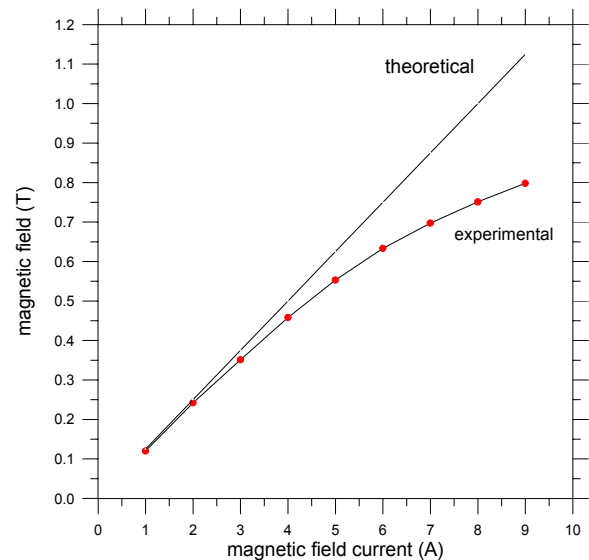

Figure 3. Magnetic field in the center of the air gap of the C-type magnet pump.

It is observed that for growing values of magnetic field currents, the difference among the theoretical and experimental data is increased, due to saturation of the magnet. For the simulation to reproduce the experimental data, it is necessary to use adjusting factors, in the calculation of magnetic field performed with the BEMC-1 code, as a function of the magnetic field current.

Performance of the electromagnetic pump that works with the Samarium-Cobalt permanent magnets depends on the magnetic field generated by the magnets. Figure 4 shows the curves of magnetic field density. The theoretical data are obtained by LMAG2D code (Abe et al., 1996). Experimental data are obtained using a set of four magnets blocks ERIMAX.

The theoretical average magnetic field calculated in EM pump active length is 0.52 Wb/m<sup>2</sup>.

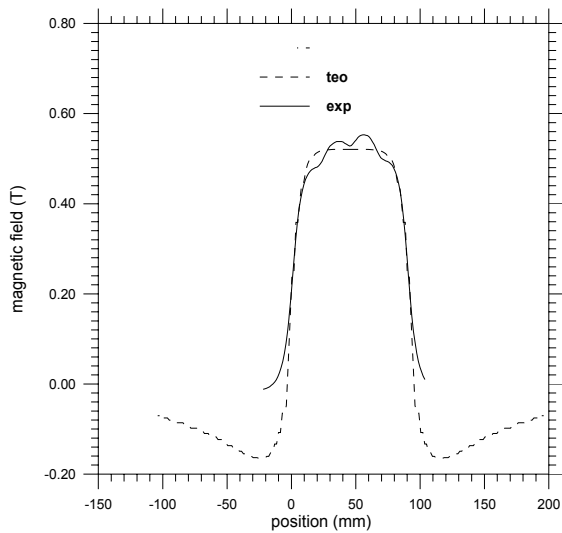

Figure 4. Theoretical and experimental magnetic field data distribution.

Figure 5 shows the experimental curve of magnetic induction in the perpendicular direction to the channel of the electromagnetic pump, along of its width. It is noticed the border effect, that it is the alteration of the close magnetic field to the outline of the magnets blocks ERIMAX, and in this case it presents sign inversion in the external area.

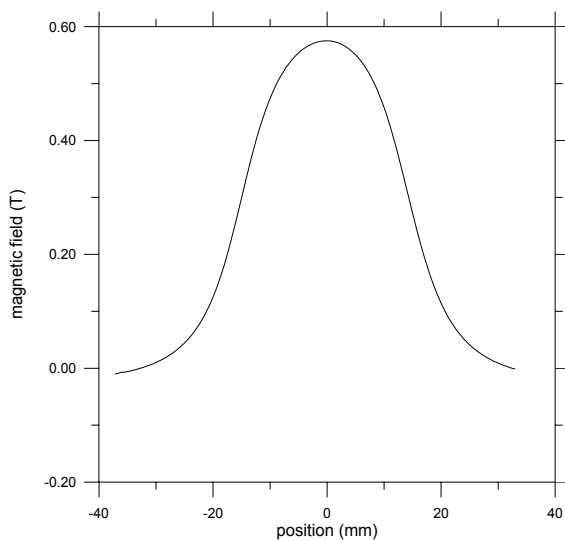

Figure 5. Experimental magnetic field data in the direction of the width of the channel.

The point zero represents the center of the magnet and the maximum value of magnetic field measured is 0.54 Wb/m<sup>2</sup>. The medium value of this curves, only made calculations in the central area interns to the channel (30 mm) it corresponds the approximately 85 % of its maximum value, being this the factor to be used previously as correction of medium magnetic field on the obtained. Therefore, it is considered as the value of experimental medium magnetic field in the active length of the channel, B = 0.44 Wb/m<sup>2</sup>, and this is used in the theoretical calculations of the electromagnetic pump Samarium-Cobalt permanent magnets.

It is observed in this parametric study the necessity of using adjustment factors in the calculation of medium magnetic field in the program BEMC-1, for the two electromagnetic pumps studied.

Table 1 shows the theoretical and experimental (correct) data of magnetic field. For not imposing new mistakes to the results obtained in the subsequent calculations, with the BEMC-1 code, the experimental magnetic field is used.

Table 1. Theoretical and experimental magnetic field.

I <sub>field</sub> (A)	2	4	6	8	SCm.
B <sub>teo</sub> (Wb/m <sup>2</sup> )	0.25	0.5	0.75	1	0.52
B <sub>exp</sub> (Wb/m <sup>2</sup> )	0.24	0.46	0.63	0.75	0.44

### Static Pressure

Figure 6 shows the experimental loop to static pressure study case (without fluid flow) of DC electromagnetic pumps. This is a loop of glasses and steel. The vertical piping are in glass, where you can verify the mercury level and the total differences level ( $\Delta L$ ), this is the static pressure produced by the electromagnetic pump, the other parts of the loop are in steel. The static pressure experimental data of electromagnetic pump can be obtained when a magnetic field and a main current are imposed. Then it is possible to measure the mercury level and the total difference level ( $\Delta L$ ).

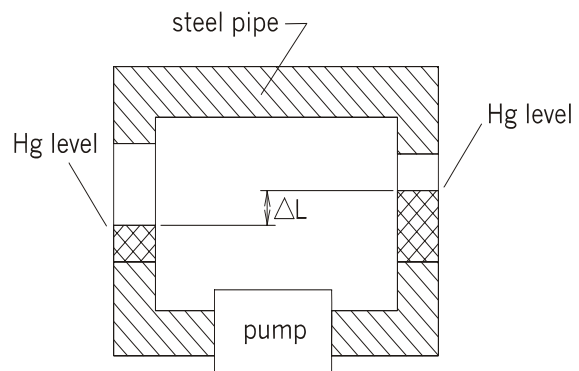

Figure 6. Experimental loop to static pressure study.

The static pressure theoretical values are obtained as a function: of the useful electric current, of the pump channel geometry and of the magnetic field experimental (or theoretical corrected).

An important parameter of DC electromagnetic pump calculation is the empiric factor used in the calculation of the electric resistance of bypass. This empiric factor is used in the calculation of the useful electric current and it depends on the geometric parameters of the pump (Watt, 1958). As higher is this factor, than minor is the loss of electric current of escape. This parameter should be adjusted for each electromagnetic pump project.

C-type DC electromagnetic pump static pressure theoretical values are obtained by Eq. (5). The useful electric current ( $I_e$ ) is calculated as a function: of the main electrical current ( $I$ ) by Eq. (8), where the last term is null, because there are no fluid flow. It is used the electric resistivity parameter of the used materials, at the working temperature and the pump channel geometry to calculate the electric resistances. Then:  $R_w=15.0 \cdot 10^{-5}$  Ohms and  $R_e= 4.0 \cdot 10^{-5}$  Ohms. Considering to C-type DC electromagnetic pump:  $R_b= 15.0 R_e$ , as was used by (Borges et al., 1995 and Borges et al., 1996-a), the static pressure theoretical curves of the pump are obtained by BEMC-1, as a function of the main electric current and of the magnetic field. Figure 7 shows the theoretical and experimental data of static pressure C-type DC electromagnetic pump.

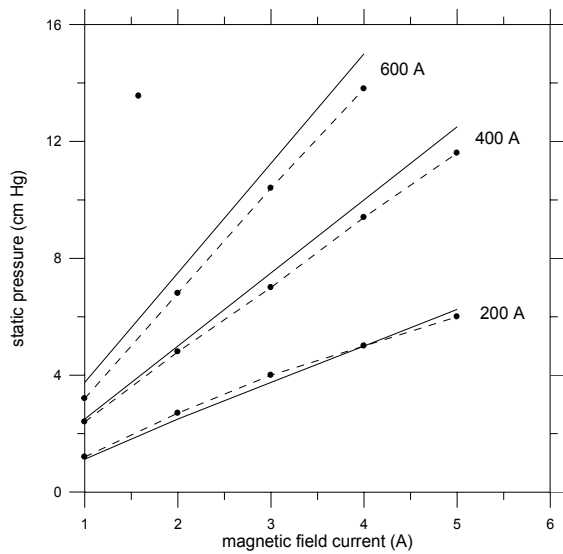

Figure 7. Theoretical and experimental data of C-type DC electromagnetic pump static pressure.

In this parametric study, the average difference among the theoretical and experimental data for the curve of static pressure is approximately 10 % for  $I = 600$  A, 5 % for  $I = 400$  A and null for  $I = 200$  A. It is possible, to use a correction factor, as a function of the main electrical current ( $I$ ), to adjust the C-type DC electromagnetic pump static pressure, as is given by:

$$P_{cor} = P_{teo}(1-f_{cor}(I-200)) \quad (9)$$

where:  $P_{cor}$  is the correct parameter value (in this case, static pressure);  $P_{teo}$  is the theoretical parameter;  $f_{cor}$  is the correction factor (0.00025); and  $I$  is the main electrical current value.

Figure 8 shows the adjusting theoretical and experimental data of C-type DC electromagnetic pump static pressure, with a good agreement.

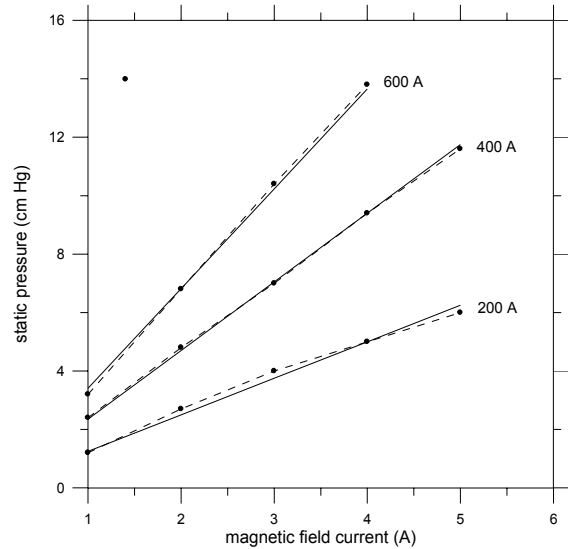

Figure 8. Adjusting theoretical and experimental data of C-type DC electromagnetic pump static pressure.

Figure 9 shows the theoretical (calculated by BEMC-1, with bypass factor:  $R_b = 5.0 R_e$ ) and experimental data of static pressure C-type DC electromagnetic pump. In this case it was not necessary to use adjusting factors.

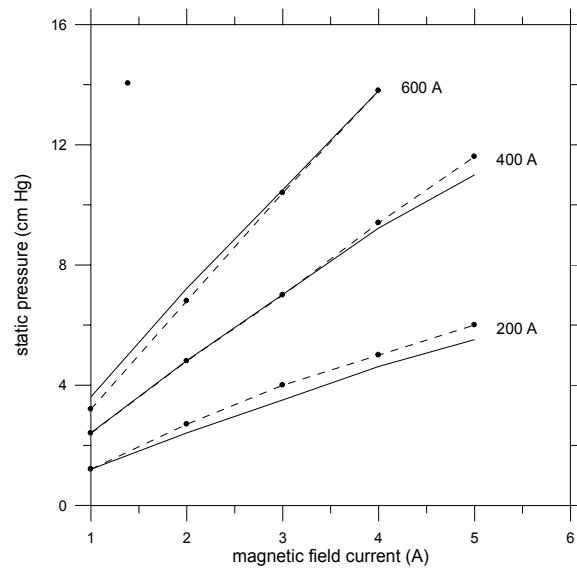

Figure 9. Theoretical and experimental data of C-type DC electromagnetic pump static pressure.

For the Samarium-Cobalt (permanent magnets) electromagnetic pump static pressure theoretical values are obtained by Eq. (5). The experimental magnetic field in the active length of the channel is  $0.44 \text{ Wb/m}^2$ . This value is used to three, four and five magnets blocks ERIMAX to theoretical evaluation by BEMC-1. The same pump channel electrical resistances are used. Then:  $R_w=15.0 \cdot 10^{-5} \text{ Ohms}$ ,  $R_e=4.0 \cdot 10^{-5} \text{ Ohms}$ , with “bypass” factor:  $R_b=5.0 R_e$ . The useful electric current ( $I_e$ ) is calculated as a function: of the main electrical current ( $I$ ) by Eq. (8), where the last term is null, because there are not fluid flow. Therefore:  $I_e = 0.68 I$ . As the pump channel height is  $a = 0.01 \text{ m}$ , the theoretical Samarium-Cobalt electromagnetic pump static pressure values are obtained by BEMC-1, by Eq. (10):

$$P = 0.022I \quad (10)$$

where:  $P$  is the static pressure, cm Hg; and  $I$  is the main electrical current, A. This equation defines pressure limit of Samarium-Cobalt electromagnetic pump performance.

Figure 10 shows the theoretical (calculated by BEMC-1) and experimental (to three, four and five constructive blocks magnets) of Samarium-Cobalt electromagnetic pump static pressure data, in function of the main electric current. In this case it is not necessary to use adjusting factors.

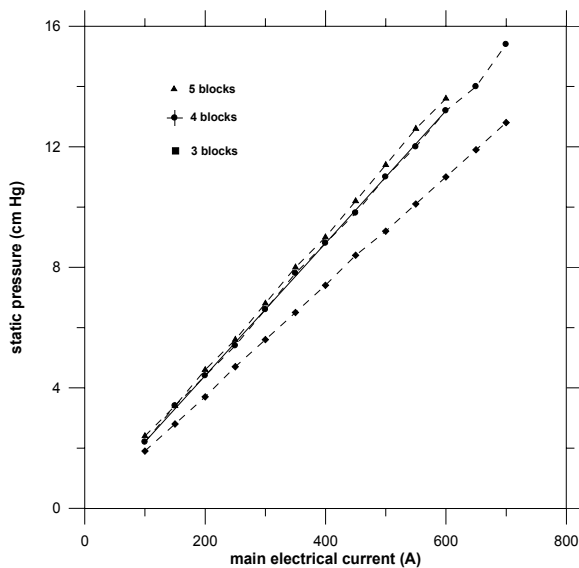

Figure 10. Samarium-Cobalt permanent magnets electromagnetic pump static pressure data.

Comparing the theoretical and experimental static pressure data to both electromagnetic pumps, it is noticed that (using the appropriated magnetic field corrections and bypass factors), the BEMC-1 code reproduces the experimental data, with almost null differences, validating the methodology used in this analysis.

### Fluid Flow

Figure 11 shows the experimental loop of the DC electromagnetic pump study case, using mercury as work fluid. This is a steel loop, where P1 and P2 are pressure gages, FM is the electromagnetic volumetric fluid flow rate meter and DS is the digital measuring system.

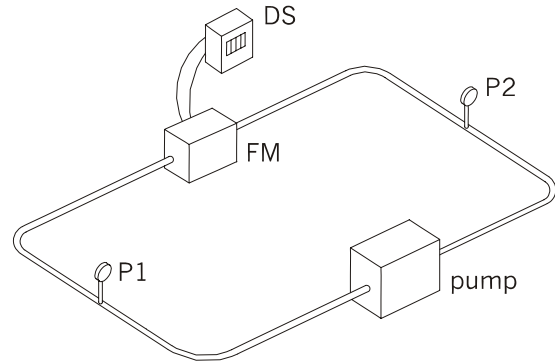

Figure 11. Experimental loop of DC electromagnetic pumps to dynamic mercury fluid flow.

Figure 12 shows the theoretical (calculated by BEMC-1) and experimental data of mercury volumetric flow rate of the C-type DC electromagnetic pump. In the theoretical evaluation by BEMC-1 is used the Eq. (8) with all terms, because in this case there is electro-countermove force resulting of the fluid moving in the magnetic field.

The mercury fluid flow supplied by C-type DC electromagnetic pump depends directly on the magnetic field and the main current values. The volumetric fluid flow measured rate is small  $6.0 \text{ l/min}$ , this value is associated to the limitations of the current sources used.

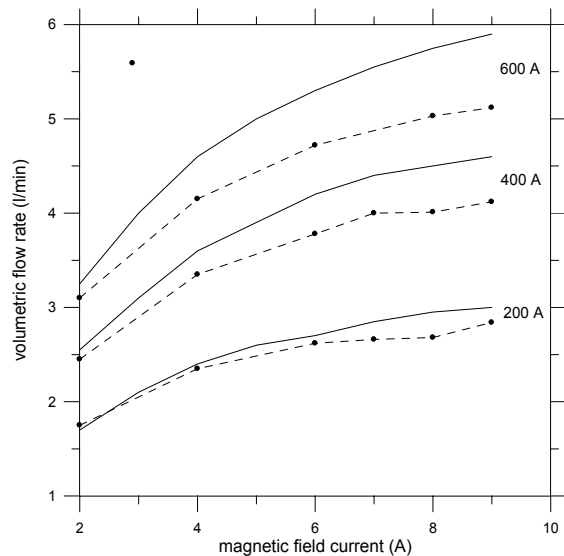

Figure 12. Theoretical and experimental data of mercury fluid flow of C-type DC EM pump.

In this parametric study, there are great differences among the theoretical and experimental data. Therefore, there is the need of the use of correction factors for the adjustment of the theoretical fluid flow curves. It was used a correction factor, as a function of the main electrical current ( $I$ ), to C-type DC electromagnetic pump adjusting volumetric fluid flow rate equal to static pressure, as is in the Eq. (9).

Figure 13 shows the adjusted theoretical and experimental data of C-type DC electromagnetic pump volumetric flow rate, with a good agreement.

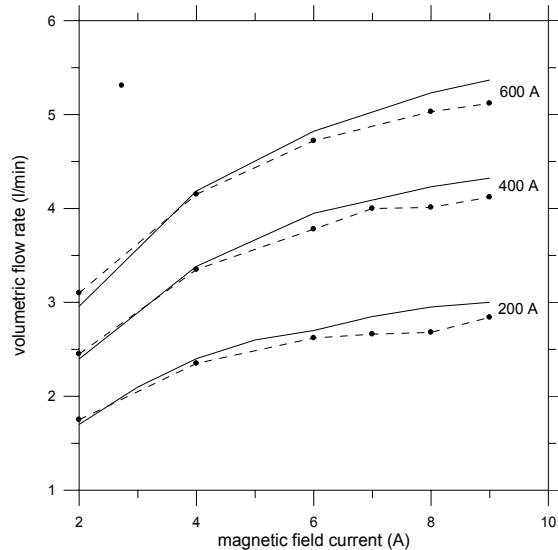

Figure 13. Adjusting theoretical and experimental data of C-type DC electromagnetic pump fluid flow.

## PERFORMANCE EVALUATION

In a DC electromagnetic pump dynamic performance theoretical evaluation, made by BEMC-1 code, should be considered the channel geometric data, the magnetic field and the main electric current to get the pump dynamic pressure curves as a function of fluid flow and to get the loop pressure loss, as a function of the volumetric fluid flow rate, too. The theoretical dynamic pressure of the DC electromagnetic pump can be obtained by Eq. (5). The useful electric current is calculated by Eq. (8), considering all terms, therefore it depends on the volumetric flow rate.

Figure 14 shows the theoretical data of the dynamic performance of the C-type DC electromagnetic pump, for three groups of magnetic field and main current values, without using adjustment factors, and the theoretical pressure loss data on the dynamic loop (with internal diameter of 0.0122 m and equivalent length of 3.8 m), as a function of the volumetric flow rate, obtained with the BEMC-1 code.

Figure 15 shows the theoretical data of the dynamic performance of the Samarium-Cobalt electromagnetic pump and pressure loss of the

dynamic loop data, as a function of the volumetric flow rate, obtained with the BEMC-1 code.

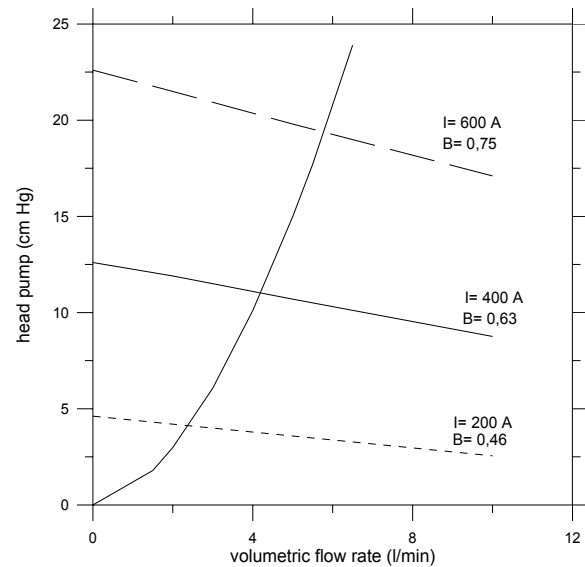

Figure 14. Theoretical dynamic performance of the C-type DC electromagnetic pump.

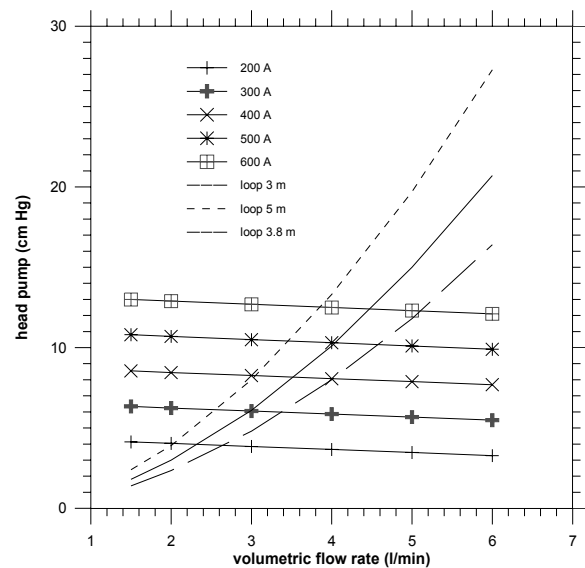

Figure 15. Theoretical dynamic performance of the Samarium-Cobalt electromagnetic pump.

The theoretical curves of the dynamic pressure and of the fluid flow are correlated, so the dynamic pressure is calculated as a function of the volumetric flow rate. It is always small than the static pressure value, for the same magnetic field and main electrical current supplied, and it should be compatible with the curve of pressure loss data of the dynamic loop.

The theoretical and experimental dynamic curves of mechanical centrifuges pumps are curved, because friction pressure loss increases with the rotation, therefore with the volumetric fluid flow rate.

The dynamic DC electromagnetic pumps curves are straight. In the case of C-type EM pump these



curves presented are not parallel, because, in this parametric study, the magnetic field values are different for each one to them.

In the case of the Samarium-Cobalt electromagnetic pump the dynamic curves are straight parallel, because in this case the magnetic field supplied is always the same.

As higher the main electric current supplied the larger the maximum pump dynamic pressure. The value of theoretical dynamic pressure, as expected, is smaller for larger fluid flows.

Figures 14 and 15 show the theoretical electromagnetic pumps operation points, those are the intersection points, with the curve of pressure loss data on dynamic loop.

## CONCLUSIONS

The BEMC-1 was developed in C++ language. It was created with the objective to evaluate each stage of the development of a DC electromagnetic pump. With this program it is possible to change all the important parameters of the pump.

In this parametric study, the correction need is observed: of the magnetic field in function of the field current, as well as, of the pressure values and flow supplied by the EM pump, in function of the main electric current used.

The evaluation of the static pressure and the dynamic operation of DC electromagnetic pump two mercury loops were used.

(Watt, 1958) affirms that the bypass factor is an empiric correction factor, that it is related with pump channel geometry. Comparing static pressure and volumetric flow rate pump data, it is noticed that this empiric factor depends of the pump operation conditions. And, still, can use adjustment factors, so that the theoretical results reproduce the experimental data.

The dynamic DC electromagnetic pump curves are straight. In the case of C-type electromagnetic pump the curves presented are not parallel. Because, in this parametric study, the magnetic field values are different for each one to them. To the Samarium-Cobalt electromagnetic pump the dynamic curves are straight parallel.

Theoretical points of DC electromagnetic pump performance in a loop are the intersection points among the straight line of pump dynamic operation and the loop pressure loss curves. It should be drawn the pump and loop curves, as a function of the volumetric fluid flow rate system.

The verified theoretical-experimental deviations determine the necessary correction factors for the simulation program. Using the adjustment factors adapted reproduces well the experimental data of magnetic field, static pressure and volumetric flow rate curves. Therefore, in spite of using models relatively simple, BEMC-1 can be used in the acting evaluation and design of a DC electromagnetic pump.

## REFERENCES

- Abe, N. M., et al., 1996, LMAG-2D: A Software Package to Teach FEA Concepts, in: VII IEEE - Conference on Electromagnetic Field Computation, Okayama, Japan.
- Armijo, J. S., et al., 1989, Thermoelectric Electro-magnetic Pump Design for the SP-100 Reference Flight System, in: VI Symposium on Space Nuclear Power Systems, Albuquerque, NM, USA.
- Atwell, J. C., et al., 1989, SP-100 Technology Accomplishments, in: VI Symposium on Space Nuclear Power Systems, Albuquerque, NM, USA.
- Borges, E. M., 1991, Desenvolvimento e Simulação Computacional de Bombas Eletromagnéticas Termoelétricas para o Controle do Escoamento em Reatores Nucleares Espaciais Refrigerados a Metal Líquido, Tese de Doutorado, Instituto Tecnológico de Aeronáutica - ITA, São José dos Campos, SP, Brasil.
- Borges, E. M., et al., 1995, Ensaio de Pressão Estática de Bomba Eletromagnética de Corrente Contínua, in: XIII Congresso Brasileiro de Engenharia Mecânica, Belo Horizonte, MG, Brasil.
- Borges, E. M., et al., 1996, Rare-Earth Magnets Applied to Liquid Metal Flow, in: XIV International Workshop on Rare-Earth Magnets and Their Applications, Sao Paulo, SP, Brazil.
- Borges, E. M., et al., 1996-a, Bomba Eletromagnética de Corrente Contínua com Imãs de Terras Raras para o Controle de Escoamento de Metais Líquidos, in: VI Congresso Latino Americano de Engenharia Mecânica, Florianópolis, SC, Brasil.
- Borges, E. M., et al., 2003, Software for DC Electromagnetic Pump Simulation - BEMC-1 In: XVII International Congress of Mechanical Engineering, Sao Paulo, SP, Brazil.
- Kwant, W., et al., 1988, PRISM Reactor Design and Development in: Safety of Next Generation Power Reactors Meeting, Washington, USA.
- Lentz, G. L., et al., 1985, EBR-II - Twenty Years of Operation Experience, in: Symposium on Fast Breeder Reactors: Experience and Trends, Lyon, France.
- Prati, A., et al., 1994, Concepção de um Reator Rápido Experimental para o Brasil In: V Congresso Geral de Energia Nuclear, Rio de Janeiro, RJ, Brasil.
- Watt, D. A., 1958, The Design of Electromagnetic Pumps for Liquid Metals, Atomic Energy Research Establishment - AERE R/R 2572, Harvel, Berkshire,.

Received: February 05, 2006

Revised: March 05, 2006

Accepted: April 05, 2006