

DYNAMIC MODEL WITH A NEW FORMULATION OF CORIOLIS/CENTRIFUGAL MATRIX FOR ROBOT MANIPULATORS

LE NGOC TRUC^{1,2}, NGUYEN VAN QUYEN¹, NGUYEN PHUNG QUANG¹

¹*Hanoi University of Science and Technology*

²*Hung Yen University of Technology and Education*

^{1,2}*lengoctruc@gmail.com*



Abstract. The paper presents a complete generalized procedure based on the Euler-Lagrange equations to build the matrix form of dynamic equations, called dynamic model, for robot manipulators. In addition, a new formulation of the Coriolis/centrifugal matrix is proposed. The link linear and angular velocities are formulated explicitly. Therefore, the translational and rotational Jacobian matrices can be derived straightforward from definition, which make the calculation of the generalized inertia matrix more convenient. By using Kronecker product, a new Coriolis/centrifugal matrix formulation is set up directly in matrix-based manner and guarantees the skew symmetry property of robot dynamic equations. This important property is usually exploited for developing many control methodologies. The validation of the proposal formulation is confirmed through the symbolic solution and simulation of a typical robot manipulator.

Keywords. Robot manipulator; Euler-Lagrange equations; Dynamic model; Coriolis/centrifugal matrix; Kronecker product.

1. INTRODUCTION

Based on the Euler-Lagrange equations, many approaches for deriving the dynamic model of robot manipulators are published [1, 6, 16, 19, 20, 21]. The important property of dynamic equations, which is often exploited for developing control algorithms (e.g., sliding mode control [8, 13], sliding mode control using neural networks [7, 13], neural-network-based control [5, 14]), is the skew symmetry that depends on the Coriolis/centrifugal matrix formulation. For satisfying the skew symmetry property, the popular method is to take advantages of Christoffel symbols of the first kind for constructing the Coriolis/centrifugal matrix; but this matrix has to be set up by combining all its elements after calculating every one of them [6, 16, 19, 20, 21].

Several types of the Coriolis/centrifugal matrix developed directly in matrix-based manner are studied to preserve the skew symmetry property; One is derived from the Lie group based recursive Newton-Euler algorithm by replacing the original Coriolis matrix of the motion equations for each body level with a modified Coriolis matrix [17]; One is obtained by dropping the term that does not contribute to the Coriolis/centrifugal force [9]; One is taken after removing a zero term from the Coriolis/centrifugal vector [3]; One is extended from [3] for geared manipulators with ideal joints [2]; And another can be simplified, after being split

into a skew-symmetric matrix and a symmetric matrix, by omitting the skew-symmetric part in the case that this part is trivial in compared to the other part [18]. Some other studies also offer a new Coriolis/centrifugal matrix, but it does not satisfy the skew symmetry property [11, 12, 15].

In our paper, taking advantages of the definitions and theorems for partial derivatives of a matrix, a product of two matrices with respect to a vector, and the time derivative of a matrix [11] using Kronecker product [4, 10, 22], we build the matrix form of dynamic equations of robot manipulators based on the Euler-Lagrange equations. Moreover, a new formulation of the Coriolis/centrifugal matrix is established directly in matrix-based manner and guarantees the skew symmetry property. In Section 2, the link velocities are derived. In Section 3, let us take a brief review about the Euler-Lagrange equations for generating dynamic equations and the definitions of Jacobian matrices for each link. In Section 4, the whole process of building the dynamic model for robot manipulators with the new Coriolis/centrifugal matrix is presented. In Section 5, the proposed formulation is applied to a typical robot manipulator for simulation and validation. Finally, Section 6 gives some important conclusions.

2. LINEAR AND ANGULAR VELOCITIES OF LINKS

If we can formulate explicitly the link linear and angular velocities then the link Jacobian matrices, as well as the total kinetic energy can be calculated easily. In this section, we derive the formulas of the linear and angular velocities. Let us consider an n -link robot manipulator with the notation that every vector variable expressed in the base frame is denoted by superscript “0”, and in the corresponding attached frame has no superscript. Denote $\boldsymbol{\omega}_i$ and $\boldsymbol{\omega}_i^0 \in \mathbb{R}^3$ for the angular velocities of link i expressed in frame i and the base frame, respectively; And their cross-product matrices are denoted by $\mathbf{S}(\boldsymbol{\omega}_i)$, $\mathbf{S}(\boldsymbol{\omega}_i^0) \in \mathbb{R}^{3 \times 3}$ as follows

$$\mathbf{S}(\boldsymbol{\omega}_i) = \begin{bmatrix} 0 & -\omega_{iz} & \omega_{iy} \\ \omega_{iz} & 0 & -\omega_{ix} \\ -\omega_{iy} & \omega_{ix} & 0 \end{bmatrix}, \quad \boldsymbol{\omega}_i = \begin{bmatrix} \omega_{ix} \\ \omega_{iy} \\ \omega_{iz} \end{bmatrix}, \quad (1)$$

$$\mathbf{S}(\boldsymbol{\omega}_i^0) = \begin{bmatrix} 0 & -\omega_{iz}^0 & \omega_{iy}^0 \\ \omega_{iz}^0 & 0 & -\omega_{ix}^0 \\ -\omega_{iy}^0 & \omega_{ix}^0 & 0 \end{bmatrix}, \quad \boldsymbol{\omega}_i^0 = \begin{bmatrix} \omega_{ix}^0 \\ \omega_{iy}^0 \\ \omega_{iz}^0 \end{bmatrix}. \quad (2)$$

Consider link i with its center of mass C_i and an arbitrary point A_i on the link (Figure 1). The base frame (frame 0) and the frame attached on link i (frame i) are denoted by $O_0x_0y_0z_0$ and $O_ix_iz_iz_i$, respectively. By means of analysis of geometric vectors, it is straightforward to show that

$$\vec{p}_{A_i} = \vec{p}_{C_i} + \vec{r}_{C_iA_i} = \vec{p}_{C_i} + (\vec{r}_{A_i} - \vec{r}_{C_i}), \quad (3)$$

where geometric vectors are denoted by the notation $\vec{(\cdot)}$; \vec{p}_{A_i} and \vec{p}_{C_i} are the length vectors between O_0 and A_i , C_i , respectively; \vec{r}_{A_i} and \vec{r}_{C_i} are the length vectors between O_i and A_i , C_i , respectively; And $\vec{r}_{C_iA_i}$ is the length vector between C_i and A_i . Based on the motion theory of a body in space, taking the time derivative of (3) yields

$$\vec{v}_{A_i} = \vec{v}_{C_i} + \vec{\omega}_i \times (\vec{r}_{A_i} - \vec{r}_{C_i}), \quad (4)$$

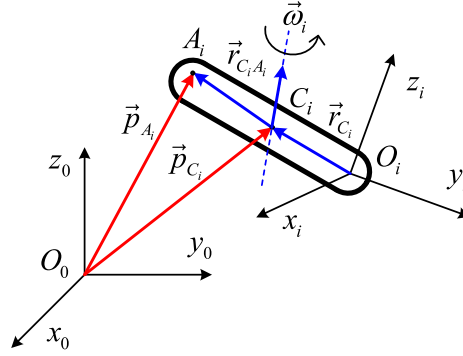

Figure 1. The linear and rotational motions of link i in space

where $\vec{v}_{A_i} = d\vec{p}_{A_i}/dt$ and $\vec{v}_{C_i} = d\vec{p}_{C_i}/dt$ are the linear velocity vectors of A_i and C_i , respectively. On the other hand, geometric vectors can be represented by algebraic vectors via their projection onto Cartesian coordinates. The algebraic vectors of $\vec{p}_{(\cdot)}$ and $\vec{r}_{(\cdot)}$ are denoted by $\mathbf{p}_{(\cdot)}$ and $\mathbf{r}_{(\cdot)} \in \mathbb{R}^3$, respectively. Projecting (3) onto the base frame has (5) and then taking the time derivatives of (5) gives (6) as

$$\begin{aligned} \mathbf{p}_{A_i}^0 &= \mathbf{p}_{C_i}^0 + (\mathbf{r}_{A_i}^0 - \mathbf{r}_{C_i}^0) \\ &= \mathbf{p}_{C_i}^0 + (\mathbf{R}_i^0 \mathbf{r}_{A_i} - \mathbf{R}_i^0 \mathbf{r}_{C_i}) \\ &= \mathbf{p}_{C_i}^0 + \mathbf{R}_i^0 (\mathbf{r}_{A_i} - \mathbf{r}_{C_i}), \end{aligned} \quad (5)$$

$$\mathbf{v}_{A_i}^0 = \mathbf{v}_{C_i}^0 + \dot{\mathbf{R}}_i^0 (\mathbf{r}_{A_i} - \mathbf{r}_{C_i}), \quad (6)$$

where $\mathbf{R}_i^0 \in \mathbb{R}^{3 \times 3}$ is the rotation matrix that expresses the orientation of frame i in the base frame. Notice that \mathbf{r}_{A_i} and \mathbf{r}_{C_i} are constant in frame i . Projecting (4) onto frame i gives

$$\begin{aligned} \mathbf{v}_{A_i} &= \mathbf{v}_{C_i} + \boldsymbol{\omega}_i \times (\mathbf{r}_{A_i} - \mathbf{r}_{C_i}) \\ &= \mathbf{v}_{C_i} + \mathbf{S}(\boldsymbol{\omega}_i) (\mathbf{r}_{A_i} - \mathbf{r}_{C_i}). \end{aligned} \quad (7)$$

Pre-multiplying both sides of (7) by \mathbf{R}_i^0 yields

$$\mathbf{R}_i^0 \mathbf{v}_{A_i} = \mathbf{R}_i^0 \mathbf{v}_{C_i} + \mathbf{R}_i^0 \mathbf{S}(\boldsymbol{\omega}_i) (\mathbf{r}_{A_i} - \mathbf{r}_{C_i}), \quad (8)$$

$$\mathbf{v}_{A_i}^0 = \mathbf{v}_{C_i}^0 + \mathbf{R}_i^0 \mathbf{S}(\boldsymbol{\omega}_i) (\mathbf{r}_{A_i} - \mathbf{r}_{C_i}). \quad (9)$$

Equating (6) and (9) one obtains

$$\mathbf{S}(\boldsymbol{\omega}_i) = (\mathbf{R}_i^0)^T \dot{\mathbf{R}}_i^0. \quad (10)$$

Besides, projecting (4) onto the base frame and using matrix \mathbf{R}_i^0 give

$$\begin{aligned} \mathbf{v}_{A_i}^0 &= \mathbf{v}_{C_i}^0 + \boldsymbol{\omega}_i^0 \times (\mathbf{r}_{A_i}^0 - \mathbf{r}_{C_i}^0) \\ &= \mathbf{v}_{C_i}^0 + \mathbf{S}(\boldsymbol{\omega}_i^0) (\mathbf{r}_{A_i}^0 - \mathbf{r}_{C_i}^0) \\ &= \mathbf{v}_{C_i}^0 + \mathbf{S}(\boldsymbol{\omega}_i^0) (\mathbf{R}_i^0 \mathbf{r}_{A_i} - \mathbf{R}_i^0 \mathbf{r}_{C_i}) \\ &= \mathbf{v}_{C_i}^0 + \mathbf{S}(\boldsymbol{\omega}_i^0) \mathbf{R}_i^0 (\mathbf{r}_{A_i} - \mathbf{r}_{C_i}). \end{aligned} \quad (11)$$

Similarly, equating (6) and (11) one obtains

$$\mathbf{S}(\boldsymbol{\omega}_i^0) = \dot{\mathbf{R}}_i^0 (\mathbf{R}_i^0)^T. \quad (12)$$

Thus, $\boldsymbol{\omega}_i$ or $\boldsymbol{\omega}_i^0$ can be formulated from (1) or (2) after finding $\mathbf{S}(\boldsymbol{\omega}_i)$ or $\mathbf{S}(\boldsymbol{\omega}_i^0)$ by (10) or (12). For common use, from now to the end of this paper, the linear velocity expressed in the base frame is re-denoted by \mathbf{v}_i^0 instead of $\mathbf{v}_{C_i}^0$, which is the time derivative of $\mathbf{p}_{C_i}^0$

$$\mathbf{v}_i^0 = \frac{d\mathbf{p}_{C_i}^0}{dt}. \quad (13)$$

By using homogeneous transformation, the link centroid $\mathbf{p}_{C_i}^0$ can be determined from \mathbf{r}_{C_i} which may be given or found out from the physical structure and configuration of link i

$$\begin{bmatrix} \mathbf{p}_{C_i}^0 \\ 1 \end{bmatrix} = \mathbf{T}_i^0 \begin{bmatrix} \mathbf{r}_{C_i} \\ 1 \end{bmatrix}, \quad (14)$$

where $\mathbf{T}_i^0 \in \mathbb{R}^{4 \times 4}$ is the homogeneous transformation that expresses the position and orientation of frame i in the base frame

$$\mathbf{T}_i^0 = \mathbf{T}_1^0 \mathbf{T}_2^1 \dots \mathbf{T}_i^{i-1} = \begin{bmatrix} \mathbf{R}_i^0 & \mathbf{p}_i^0 \\ \mathbf{0}^T & 1 \end{bmatrix}, \quad (15)$$

where $\mathbf{p}_i^0 \in \mathbb{R}^3$ is the origin of frame i with respect to the base frame.

3. A BRIEF REVIEW OF EULER-LAGRANGE EQUATIONS FOR DYNAMICS OF ROBOT MANIPULATORS

The Euler-Lagrange equations which is deployed for generating the equations of motion of robot manipulators are given as

$$\frac{d}{dt} \left(\frac{\partial L}{\partial \dot{\mathbf{q}}} \right)^T - \left(\frac{\partial L}{\partial \mathbf{q}} \right)^T = \boldsymbol{\tau}, \quad (16)$$

where $L = K - P$ is the Lagrangian function; K and P are the total kinetic and potential energy, respectively; $\boldsymbol{\tau} \in \mathbb{R}^n$ is the general force/torque vector; $\mathbf{q} \in \mathbb{R}^n$ is the vector of joint variables, and $\dot{\mathbf{q}}$ is its first time derivative. P and K are obtained by

$$P = - \sum_{i=1}^n m_i (\mathbf{g}^0)^T \mathbf{p}_{C_i}^0, \quad (17)$$

$$K = \sum_{i=1}^n \left(\frac{1}{2} m_i (\mathbf{v}_i^0)^T \mathbf{v}_i^0 + \frac{1}{2} (\boldsymbol{\omega}_i^0)^T \mathbf{I}_i^0 \boldsymbol{\omega}_i^0 \right) \quad (18)$$

with $\mathbf{g}^0 = [0, 0, -g]^T$ is the gravitational acceleration vector, $g = 9.807$ (m/s²); m_i is the mass of link i ; $\mathbf{I}_i^0 \in \mathbb{R}^{3 \times 3}$ is the link inertia tensor with respect to the base frame. Let us denote $\mathbf{I}_i \in \mathbb{R}^{3 \times 3}$ for the link inertia tensor with respect to the frame attached at the link centroid and parallel to the body frame. The relation between \mathbf{I}_i^0 and \mathbf{I}_i is given by

$$\mathbf{I}_i^0 = \mathbf{R}_i^0 \mathbf{I}_i (\mathbf{R}_i^0)^T. \quad (19)$$

Based on the shape, structure, and material of link i , matrix \mathbf{I}_i may be approximated at a sufficient accuracy. Substituting (19) into (18) yields

$$K = \sum_{i=1}^n \left(\frac{1}{2} m_i (\mathbf{v}_i^0)^T \mathbf{v}_i^0 + \frac{1}{2} (\boldsymbol{\omega}_i^0)^T \mathbf{R}_i^0 \mathbf{I}_i (\mathbf{R}_i^0)^T \boldsymbol{\omega}_i^0 \right). \quad (20)$$

The transformation between $\boldsymbol{\omega}_i$ and $\boldsymbol{\omega}_i^0$ is given by

$$\boldsymbol{\omega}_i^0 = \mathbf{R}_i^0 \boldsymbol{\omega}_i. \quad (21)$$

Substituting (21) into (20) results in a compacted expression as

$$K = \sum_{i=1}^n \left(\frac{1}{2} m_i (\mathbf{v}_i^0)^T \mathbf{v}_i^0 + \frac{1}{2} \boldsymbol{\omega}_i^T \mathbf{I}_i \boldsymbol{\omega}_i \right). \quad (22)$$

The rotational and translational Jacobian matrices related to $\boldsymbol{\omega}_i^0$ and \mathbf{v}_i^0 : $\mathbf{J}_{R_i}^0 \in \mathbb{R}^{3 \times n}$ and $\mathbf{J}_{T_i}^0 \in \mathbb{R}^{3 \times n}$, respectively, can be defined by

$$\mathbf{J}_{R_i}^0 = \frac{\partial \boldsymbol{\omega}_i^0}{\partial \dot{\mathbf{q}}}, \quad (23)$$

$$\mathbf{J}_{T_i}^0 = \frac{\partial \mathbf{v}_i^0}{\partial \dot{\mathbf{q}}} = \frac{\partial \mathbf{p}_{C_i}^0}{\partial \dot{\mathbf{q}}}. \quad (24)$$

Additionally, the rotational Jacobian matrix $\mathbf{J}_{R_i} \in \mathbb{R}^{3 \times n}$ related to $\boldsymbol{\omega}_i$ can be defined as

$$\mathbf{J}_{R_i} = \frac{\partial \boldsymbol{\omega}_i}{\partial \dot{\mathbf{q}}}. \quad (25)$$

From the definitions of two parts of manipulator Jacobian depicted in (24) and (25), we have

$$\mathbf{v}_i^0 = \mathbf{J}_{T_i}^0 \dot{\mathbf{q}}, \quad \boldsymbol{\omega}_i = \mathbf{J}_{R_i} \dot{\mathbf{q}}. \quad (26)$$

Substituting (26) into (22) yields the total kinetic energy as

$$\begin{aligned} K &= \sum_{i=1}^n \left(\frac{1}{2} m_i \dot{\mathbf{q}}^T (\mathbf{J}_{T_i}^0)^T \mathbf{J}_{T_i}^0 \dot{\mathbf{q}} + \frac{1}{2} \dot{\mathbf{q}}^T \mathbf{J}_{R_i}^T \mathbf{I}_i \mathbf{J}_{R_i} \dot{\mathbf{q}} \right) \\ &= \frac{1}{2} \dot{\mathbf{q}}^T \left[\sum_{i=1}^n \left(m_i (\mathbf{J}_{T_i}^0)^T \mathbf{J}_{T_i}^0 + \mathbf{J}_{R_i}^T \mathbf{I}_i \mathbf{J}_{R_i} \right) \right] \dot{\mathbf{q}} = \frac{1}{2} \dot{\mathbf{q}}^T \mathbf{M} \dot{\mathbf{q}}, \end{aligned} \quad (27)$$

where $\mathbf{M} \in \mathbb{R}^{n \times n}$ is called the generalized inertia matrix that is symmetric and positive definite

$$\mathbf{M} = \sum_{i=1}^n \left(m_i (\mathbf{J}_{T_i}^0)^T \mathbf{J}_{T_i}^0 + \mathbf{J}_{R_i}^T \mathbf{I}_i \mathbf{J}_{R_i} \right). \quad (28)$$

4. DYNAMIC MODEL WITH A NEW FORMULATION OF CORIOLIS/CENTRIFUGAL MATRIX FOR ROBOT MANIPULATORS

The general dynamic model of robot manipulators is as follows without considering friction

$$\boldsymbol{\tau} = \mathbf{M}\ddot{\mathbf{q}} + \mathbf{C}\dot{\mathbf{q}} + \mathbf{g}, \quad (29)$$

where $\boldsymbol{\tau}$, \mathbf{M} , and \mathbf{q} are defined in the previous section; $\mathbf{C} \in \mathbb{R}^{n \times n}$ is the Coriolis/centrifugal matrix; $\mathbf{g} \in \mathbb{R}^n$ is the vector of gravity term. Foremost, we take a review of some definitions and theorems about Kronecker product; Partial derivatives of a matrix, a product of two matrices with respect to a vector; And the time derivative of a matrix.

Definition 1. The Kronecker product of two matrices $\mathbf{D} \in \mathbb{R}^{p \times q}$ and $\mathbf{H} \in \mathbb{R}^{r \times s}$ is $(\mathbf{D} \otimes \mathbf{H}) \in \mathbb{R}^{pr \times qs}$ defined as [4, 10, 22]

$$\mathbf{D} \otimes \mathbf{H} = \begin{bmatrix} d_{11}\mathbf{H} & d_{12}\mathbf{H} & \cdots & d_{1q}\mathbf{H} \\ d_{21}\mathbf{H} & d_{22}\mathbf{H} & \cdots & d_{2q}\mathbf{H} \\ \vdots & \vdots & \ddots & \vdots \\ d_{p1}\mathbf{H} & d_{p2}\mathbf{H} & \cdots & d_{pq}\mathbf{H} \end{bmatrix}, \quad (30)$$

where \otimes denotes Kronecker product operator.

Definition 2. The partial derivative of any matrix $\mathbf{D}(\mathbf{x}) \in \mathbb{R}^{p \times q}$ with respect to vector $\mathbf{x} \in \mathbb{R}^r$ is defined as a $p \times qr$ matrix [11]

$$\frac{\partial \mathbf{D}}{\partial \mathbf{x}} = \begin{bmatrix} \frac{\partial d_{11}}{\partial \mathbf{x}} & \frac{\partial d_{12}}{\partial \mathbf{x}} & \cdots & \frac{\partial d_{1q}}{\partial \mathbf{x}} \\ \frac{\partial d_{21}}{\partial \mathbf{x}} & \frac{\partial d_{22}}{\partial \mathbf{x}} & \cdots & \frac{\partial d_{2q}}{\partial \mathbf{x}} \\ \vdots & \vdots & \ddots & \vdots \\ \frac{\partial d_{p1}}{\partial \mathbf{x}} & \frac{\partial d_{p2}}{\partial \mathbf{x}} & \cdots & \frac{\partial d_{pq}}{\partial \mathbf{x}} \end{bmatrix} = \begin{bmatrix} \frac{\partial d_{11}}{\partial x_1} \cdots \frac{\partial d_{11}}{\partial x_r} & \frac{\partial d_{12}}{\partial x_1} \cdots \frac{\partial d_{12}}{\partial x_r} & \cdots & \frac{\partial d_{1q}}{\partial x_1} \cdots \frac{\partial d_{1q}}{\partial x_r} \\ \frac{\partial d_{21}}{\partial x_1} \cdots \frac{\partial d_{21}}{\partial x_r} & \frac{\partial d_{22}}{\partial x_1} \cdots \frac{\partial d_{22}}{\partial x_r} & \cdots & \frac{\partial d_{2q}}{\partial x_1} \cdots \frac{\partial d_{2q}}{\partial x_r} \\ \vdots & \vdots & \ddots & \vdots \\ \frac{\partial d_{p1}}{\partial x_1} \cdots \frac{\partial d_{p1}}{\partial x_r} & \frac{\partial d_{p2}}{\partial x_1} \cdots \frac{\partial d_{p2}}{\partial x_r} & \cdots & \frac{\partial d_{pq}}{\partial x_1} \cdots \frac{\partial d_{pq}}{\partial x_r} \end{bmatrix}. \quad (31)$$

Theorem 1. The partial derivative of the product of two matrices $\mathbf{D}(\mathbf{x}) \in \mathbb{R}^{p \times q}$ and $\mathbf{H}(\mathbf{x}) \in \mathbb{R}^{q \times s}$ with respect to vector $\mathbf{x} \in \mathbb{R}^r$ is given by [11]

$$\frac{\partial}{\partial \mathbf{x}} (\mathbf{D}\mathbf{H}) = \frac{\partial \mathbf{D}}{\partial \mathbf{x}} (\mathbf{H} \otimes \mathbf{1}_r) + \mathbf{D} \frac{\partial \mathbf{H}}{\partial \mathbf{x}}, \quad (32)$$

where $\mathbf{1}_r \in \mathbb{R}^{r \times r}$ is the identity matrix.

Theorem 2. The time derivative of matrix $\mathbf{D}(\mathbf{x}) \in \mathbb{R}^{p \times q}$, with $\mathbf{x} \in \mathbb{R}^r$, is calculated by [11]

$$\dot{\mathbf{D}} = \frac{\partial \mathbf{D}}{\partial \mathbf{x}} (\mathbf{1}_r \otimes \dot{\mathbf{x}}). \quad (33)$$

The detailed proofs of both theorems are presented clearly in [11]. In the following, the matrix form (29) can be built based on the Euler-Lagrange equations (16) by using the above

definitions and theorems. Applying (27) to the Lagrangian function, and assigning $\mathbf{h} = \mathbf{M}\dot{\mathbf{q}}$ yield

$$L = \frac{1}{2}\dot{\mathbf{q}}^T \mathbf{M}\dot{\mathbf{q}} - P = \frac{1}{2}\dot{\mathbf{q}}^T \mathbf{h} - P. \quad (34)$$

Substituting (34) into (16) and using Theorem 1 including both Definition 1 and Definition 2, the partial derivative inside the first term of (16) can be written as

$$\frac{\partial L}{\partial \dot{\mathbf{q}}} = \frac{1}{2} \frac{\partial}{\partial \dot{\mathbf{q}}} (\dot{\mathbf{q}}^T \mathbf{h}) = \frac{1}{2} \left(\frac{\partial \dot{\mathbf{q}}^T}{\partial \dot{\mathbf{q}}} (\mathbf{h} \otimes \mathbf{1}_n) + \dot{\mathbf{q}}^T \frac{\partial \mathbf{h}}{\partial \dot{\mathbf{q}}} \right), \quad (35)$$

where $\mathbf{1}_n \in \mathbb{R}^{n \times n}$ is the identity matrix. Each term on the right side of (35) can be represented as

$$\begin{aligned} \frac{\partial \dot{\mathbf{q}}^T}{\partial \dot{\mathbf{q}}} (\mathbf{h} \otimes \mathbf{1}_n) &= [\mathbf{e}_1^T \quad \cdots \quad \mathbf{e}_n^T] \begin{bmatrix} h_1 \mathbf{1}_n \\ \vdots \\ h_n \mathbf{1}_n \end{bmatrix} = [h_1 \mathbf{e}_1^T \mathbf{1}_n \quad \cdots \quad h_n \mathbf{e}_n^T \mathbf{1}_n] \\ &= [h_1 \quad \cdots \quad h_n] = \mathbf{h}^T = \dot{\mathbf{q}}^T \mathbf{M}, \end{aligned} \quad (36)$$

$$\begin{aligned} \dot{\mathbf{q}}^T \frac{\partial \mathbf{h}}{\partial \dot{\mathbf{q}}} &= \dot{\mathbf{q}}^T \frac{\partial}{\partial \dot{\mathbf{q}}} (\mathbf{M}\dot{\mathbf{q}}) = \dot{\mathbf{q}}^T \left(\frac{\partial \mathbf{M}}{\partial \dot{\mathbf{q}}} (\dot{\mathbf{q}} \otimes \mathbf{1}_n) + \mathbf{M} \frac{\partial \dot{\mathbf{q}}}{\partial \dot{\mathbf{q}}} \right) \\ &= \dot{\mathbf{q}}^T (\mathbf{0} + \mathbf{M}) = \dot{\mathbf{q}}^T \mathbf{M}, \end{aligned} \quad (37)$$

with $\mathbf{e}_i \in \mathbb{R}^n$ is the i th column vector of $\mathbf{1}_n$. Substituting (36) and (37) into (35) yields

$$\frac{\partial L}{\partial \dot{\mathbf{q}}} = \dot{\mathbf{q}}^T \mathbf{M}. \quad (38)$$

Transposing and taking the time derivative of (38) give

$$\frac{d}{dt} \left(\frac{\partial L}{\partial \dot{\mathbf{q}}} \right)^T = \mathbf{M}\ddot{\mathbf{q}} + \dot{\mathbf{M}}\dot{\mathbf{q}} = \mathbf{M}\ddot{\mathbf{q}} + \frac{\partial \mathbf{M}}{\partial \mathbf{q}} (\mathbf{1}_n \otimes \dot{\mathbf{q}}) \dot{\mathbf{q}}, \quad (39)$$

where using Theorem 2 takes the time derivative of the generalized inertia matrix as

$$\dot{\mathbf{M}} = \frac{\partial \mathbf{M}}{\partial \mathbf{q}} (\mathbf{1}_n \otimes \dot{\mathbf{q}}). \quad (40)$$

Similarly, for the second term of the Euler-Lagrange equations (16) one obtains

$$\frac{\partial L}{\partial \mathbf{q}} = \frac{1}{2} \frac{\partial}{\partial \mathbf{q}} (\dot{\mathbf{q}}^T \mathbf{h}) - \frac{\partial P}{\partial \mathbf{q}}. \quad (41)$$

The first term on the right side of (41) can be rewritten in the form

$$\begin{aligned} \frac{\partial}{\partial \mathbf{q}} (\dot{\mathbf{q}}^T \mathbf{h}) &= \left(\frac{\partial \dot{\mathbf{q}}^T}{\partial \mathbf{q}} (\mathbf{h} \otimes \mathbf{1}_n) + \dot{\mathbf{q}}^T \frac{\partial \mathbf{h}}{\partial \mathbf{q}} \right) = \left(\mathbf{0} + \dot{\mathbf{q}}^T \frac{\partial (\mathbf{M}\dot{\mathbf{q}})}{\partial \mathbf{q}} \right) \\ &= \dot{\mathbf{q}}^T \left(\frac{\partial \mathbf{M}}{\partial \mathbf{q}} (\dot{\mathbf{q}} \otimes \mathbf{1}_n) + \mathbf{M} \frac{\partial \dot{\mathbf{q}}}{\partial \mathbf{q}} \right) = \dot{\mathbf{q}}^T \frac{\partial \mathbf{M}}{\partial \mathbf{q}} (\dot{\mathbf{q}} \otimes \mathbf{1}_n). \end{aligned} \quad (42)$$

Substituting (42) into (41) and transposing both sides of (41) yield

$$\left(\frac{\partial L}{\partial \mathbf{q}}\right)^T = \frac{1}{2} \left(\frac{\partial \mathbf{M}}{\partial \mathbf{q}} (\dot{\mathbf{q}} \otimes \mathbf{1}_n)\right)^T \dot{\mathbf{q}} - \left(\frac{\partial P}{\partial \mathbf{q}}\right)^T. \quad (43)$$

Eventually, substituting (39) and (43) into the Euler-Lagrange equations (16) generates the dynamic model of robot manipulators

$$\begin{aligned} \boldsymbol{\tau} &= \mathbf{M}\ddot{\mathbf{q}} + \frac{\partial \mathbf{M}}{\partial \mathbf{q}} (\mathbf{1}_n \otimes \dot{\mathbf{q}}) \dot{\mathbf{q}} - \frac{1}{2} \left(\frac{\partial \mathbf{M}}{\partial \mathbf{q}} (\dot{\mathbf{q}} \otimes \mathbf{1}_n)\right)^T \dot{\mathbf{q}} + \left(\frac{\partial P}{\partial \mathbf{q}}\right)^T \\ &= \mathbf{M}\ddot{\mathbf{q}} + \mathbf{C}\dot{\mathbf{q}} + \mathbf{g}, \end{aligned} \quad (44)$$

where the two vectors of gravity, Coriolis/centrifugal terms are

$$\mathbf{g} = \left(\frac{\partial P}{\partial \mathbf{q}}\right)^T, \quad (45)$$

$$\mathbf{C}\dot{\mathbf{q}} = \frac{\partial \mathbf{M}}{\partial \mathbf{q}} (\mathbf{1}_n \otimes \dot{\mathbf{q}}) \dot{\mathbf{q}} - \frac{1}{2} \left(\frac{\partial \mathbf{M}}{\partial \mathbf{q}} (\dot{\mathbf{q}} \otimes \mathbf{1}_n)\right)^T \dot{\mathbf{q}}. \quad (46)$$

From (46), the requirement is to extract matrix \mathbf{C} that satisfies the skew-symmetric property of matrix $\dot{\mathbf{M}} - 2\mathbf{C}$. There is a kind of matrix \mathbf{C} taken from (46) (presented in [11, 12]); But it does not assure the mentioned property. To achieve this objective, we give a lemma as follows.

Lemma 1. Consider a vector $\mathbf{x} \in \mathbb{R}^n$ and the identity matrix $\mathbf{1}_m \in \mathbb{R}^{m \times m}$. The two products $(\mathbf{1}_m \otimes \mathbf{x}) \mathbf{x}$ and $(\mathbf{x} \otimes \mathbf{1}_m) \mathbf{x}$ exist if $n = m$, and the following rule is satisfied

$$(\mathbf{1}_m \otimes \mathbf{x}) \mathbf{x} = (\mathbf{x} \otimes \mathbf{1}_m) \mathbf{x}. \quad (47)$$

Proof. We have

$$(\mathbf{1}_m \otimes \mathbf{x}) \mathbf{x} = (\mathbf{1}_n \otimes \mathbf{x}) \mathbf{x} = \begin{bmatrix} \mathbf{x} & \cdots & \mathbf{0} \\ \vdots & \ddots & \vdots \\ \mathbf{0} & \cdots & \mathbf{x} \end{bmatrix} \mathbf{x} = \begin{bmatrix} \mathbf{x}x_1 \\ \vdots \\ \mathbf{x}x_n \end{bmatrix} = \begin{bmatrix} x_1\mathbf{x} \\ \vdots \\ x_n\mathbf{x} \end{bmatrix}, \quad (48)$$

$$(\mathbf{x} \otimes \mathbf{1}_m) \mathbf{x} = (\mathbf{x} \otimes \mathbf{1}_n) \mathbf{x} = \begin{bmatrix} x_1\mathbf{1}_n \\ \vdots \\ x_n\mathbf{1}_n \end{bmatrix} \mathbf{x} = \begin{bmatrix} x_1\mathbf{1}_n\mathbf{x} \\ \vdots \\ x_n\mathbf{1}_n\mathbf{x} \end{bmatrix} = \begin{bmatrix} x_1\mathbf{x} \\ \vdots \\ x_n\mathbf{x} \end{bmatrix}. \quad (49)$$

Obviously, Lemma 1 is proven because the right sides of (48) and (49) are identical. ■

Applying Lemma 1 with vector $\dot{\mathbf{q}} \in \mathbb{R}^n$ and the identity matrix $\mathbf{1}_n \in \mathbb{R}^{n \times n}$ gives

$$(\mathbf{1}_n \otimes \dot{\mathbf{q}}) \dot{\mathbf{q}} = (\dot{\mathbf{q}} \otimes \mathbf{1}_n) \dot{\mathbf{q}}. \quad (50)$$

Splitting the first term of the right side of (46) into two equal parts, then substituting (50) into one of them yields

$$\begin{aligned} \mathbf{C}\dot{\mathbf{q}} &= \frac{1}{2} \frac{\partial \mathbf{M}}{\partial \mathbf{q}} (\mathbf{1}_n \otimes \dot{\mathbf{q}}) \dot{\mathbf{q}} + \frac{1}{2} \frac{\partial \mathbf{M}}{\partial \mathbf{q}} (\dot{\mathbf{q}} \otimes \mathbf{1}_n) \dot{\mathbf{q}} - \frac{1}{2} \left(\frac{\partial \mathbf{M}}{\partial \mathbf{q}} (\dot{\mathbf{q}} \otimes \mathbf{1}_n)\right)^T \dot{\mathbf{q}} \\ &= \frac{1}{2} \left[\frac{\partial \mathbf{M}}{\partial \mathbf{q}} (\mathbf{1}_n \otimes \dot{\mathbf{q}}) + \frac{\partial \mathbf{M}}{\partial \mathbf{q}} (\dot{\mathbf{q}} \otimes \mathbf{1}_n) - \left(\frac{\partial \mathbf{M}}{\partial \mathbf{q}} (\dot{\mathbf{q}} \otimes \mathbf{1}_n)\right)^T \right] \dot{\mathbf{q}}. \end{aligned} \quad (51)$$

The proposal formulation of the Coriolis/centrifugal matrix is extracted from (51) as

$$\mathbf{C} = \frac{1}{2} \left[\frac{\partial \mathbf{M}}{\partial \mathbf{q}} (\mathbf{1}_n \otimes \dot{\mathbf{q}}) + \frac{\partial \mathbf{M}}{\partial \mathbf{q}} (\dot{\mathbf{q}} \otimes \mathbf{1}_n) - \left(\frac{\partial \mathbf{M}}{\partial \mathbf{q}} (\dot{\mathbf{q}} \otimes \mathbf{1}_n) \right)^T \right]. \quad (52)$$

The matrix \mathbf{C} in (52) solidly guarantees $\dot{\mathbf{M}} - 2\mathbf{C}$ is skew-symmetric. Indeed, let us assign

$$\mathbf{U} = \frac{\partial \mathbf{M}}{\partial \mathbf{q}} (\mathbf{1}_n \otimes \dot{\mathbf{q}}), \quad \mathbf{V} = \frac{\partial \mathbf{M}}{\partial \mathbf{q}} (\dot{\mathbf{q}} \otimes \mathbf{1}_n). \quad (53)$$

Thus,

$$\dot{\mathbf{M}} = \mathbf{U}, \quad \mathbf{C} = (1/2)(\mathbf{U} + \mathbf{V} - \mathbf{V}^T), \quad (54)$$

and it deduces

$$\dot{\mathbf{M}} - 2\mathbf{C} = \mathbf{U} - (\mathbf{U} + \mathbf{V} - \mathbf{V}^T) = \mathbf{V}^T - \mathbf{V}. \quad (55)$$

Therefore, $\dot{\mathbf{M}} - 2\mathbf{C}$ is skew-symmetric because $\mathbf{V}^T - \mathbf{V}$ is skew-symmetric with an arbitrary square matrix \mathbf{V} .

5. APPLICATION EXAMPLE

To illustrate how the new formulation of the Coriolis/centrifugal matrix can be applied to the dynamic model of robot manipulators as well as to validate the proposal, let us consider a three-link manipulator described in Figure 2 ([16], page 172). Beyond the set of the previous notations, the more applied for this example are as follows l_{i-1} is the length of link i ; r_{i-1} is the distance between the center of joint i and the centroid of link i ; I_{ixx} , I_{iyy} , and I_{izz} are three principal moments of inertia of link i , ($i = 1, 2, 3$). All the cross products of inertia of link i are zero because of the assumption that the mass distribution of link i is symmetric. The manipulator configuration and the choice of attached frames are shown in Figure 2, and the D-H parameters are obtained in Table 1.

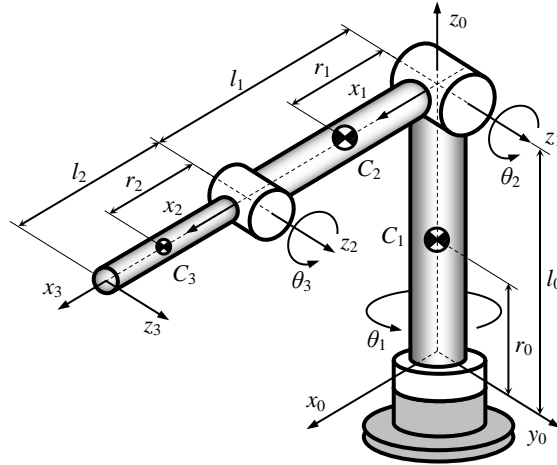

Figure 2. A three-link manipulator

Table 1. D-H parameters of the three-link manipulator

Joint i	θ_i (rad)	d_i (m)	a_i (m)	α_i (rad)
1	q_1	$d_1 = l_0$	$a_1 = 0$	$\alpha_1 = -\pi/2$
2	q_2	$d_2 = 0$	$a_2 = l_1$	$\alpha_2 = 0$
3	q_3	$d_3 = 0$	$a_3 = l_2$	$\alpha_3 = 0$

It is easy to derive all the homogeneous transformation matrices

$$\begin{aligned} \mathbf{T}_1^0 &= \begin{bmatrix} c_1 & 0 & -s_1 & 0 \\ s_1 & 0 & c_1 & 0 \\ 0 & -1 & 0 & l_0 \\ 0 & 0 & 0 & 1 \end{bmatrix}, \quad \mathbf{T}_2^0 = \begin{bmatrix} c_1 c_2 & -c_1 s_2 & -s_1 & l_1 c_1 c_2 \\ s_1 c_2 & -s_1 s_2 & c_1 & l_1 s_1 c_2 \\ -s_2 & -c_2 & 0 & l_0 - l_1 s_2 \\ 0 & 0 & 0 & 1 \end{bmatrix}, \\ \mathbf{T}_3^0 &= \begin{bmatrix} c_1 c_{23} & -c_1 s_{23} & -s_1 & c_1 (l_1 c_2 + c_{23} l_2) \\ s_1 c_{23} & -s_1 s_{23} & c_1 & s_1 (l_1 c_2 + c_{23} l_2) \\ -s_{23} & -c_{23} & 0 & l_0 - l_1 s_2 - l_2 s_{23} \\ 0 & 0 & 0 & 1 \end{bmatrix}, \end{aligned} \quad (56)$$

where s_i , c_i , s_{ij} , and c_{ij} represent $\sin(q_i)$, $\cos(q_i)$, $\sin(q_i + q_j)$, and $\cos(q_i + q_j)$, respectively, ($i, j = 1, 2, 3$). Thus, three rotation matrices \mathbf{R}_1^0 , \mathbf{R}_2^0 , and \mathbf{R}_3^0 are extracted from (56) as

$$\mathbf{R}_1^0 = \begin{bmatrix} c_1 & 0 & -s_1 \\ s_1 & 0 & c_1 \\ 0 & -1 & 0 \end{bmatrix}, \quad \mathbf{R}_2^0 = \begin{bmatrix} c_1 c_2 & -c_1 s_2 & -s_1 \\ s_1 c_2 & -s_1 s_2 & c_1 \\ -s_2 & -c_2 & 0 \end{bmatrix}, \quad \mathbf{R}_3^0 = \begin{bmatrix} c_1 c_{23} & -c_1 s_{23} & -s_1 \\ s_1 c_{23} & -s_1 s_{23} & c_1 \\ -s_{23} & -c_{23} & 0 \end{bmatrix}. \quad (57)$$

Substituting (57) into (10) calculates cross-product matrices $\mathbf{S}(\boldsymbol{\omega}_1)$, $\mathbf{S}(\boldsymbol{\omega}_2)$, and $\mathbf{S}(\boldsymbol{\omega}_3)$. Afterwards, the angular velocities are formulated as

$$\boldsymbol{\omega}_1 = \begin{bmatrix} 0 \\ -\dot{q}_1 \\ 0 \end{bmatrix}, \quad \boldsymbol{\omega}_2 = \begin{bmatrix} -s_2 \dot{q}_1 \\ -c_2 \dot{q}_1 \\ \dot{q}_2 \end{bmatrix}, \quad \boldsymbol{\omega}_3 = \begin{bmatrix} -s_{23} \dot{q}_1 \\ -c_{23} \dot{q}_1 \\ \dot{q}_2 + \dot{q}_3 \end{bmatrix}. \quad (58)$$

Applying (58) to (25) we obtain the three rotational Jacobian matrices

$$\mathbf{J}_{R_1} = \frac{\partial \boldsymbol{\omega}_1}{\partial \dot{\mathbf{q}}} = \begin{bmatrix} 0 & 0 & 0 \\ -1 & 0 & 0 \\ 0 & 0 & 0 \end{bmatrix}, \quad \mathbf{J}_{R_2} = \frac{\partial \boldsymbol{\omega}_2}{\partial \dot{\mathbf{q}}} = \begin{bmatrix} -s_2 & 0 & 0 \\ -c_2 & 0 & 0 \\ 0 & 1 & 0 \end{bmatrix}, \quad \mathbf{J}_{R_3} = \frac{\partial \boldsymbol{\omega}_3}{\partial \dot{\mathbf{q}}} = \begin{bmatrix} -s_{23} & 0 & 0 \\ -c_{23} & 0 & 0 \\ 0 & 1 & 1 \end{bmatrix}. \quad (59)$$

According to the description shown in Figure 2, the position vectors of the link centroids with respect to the corresponding attached frames are

$$\mathbf{r}_{C_1} = \begin{bmatrix} 0 \\ l_0 - r_0 \\ 0 \end{bmatrix}, \quad \mathbf{r}_{C_2} = \begin{bmatrix} r_1 - l_1 \\ 0 \\ 0 \end{bmatrix}, \quad \mathbf{r}_{C_3} = \begin{bmatrix} r_2 - l_2 \\ 0 \\ 0 \end{bmatrix}. \quad (60)$$

Then the position vectors of link centroids with respect to the base frame are computed by substituting (60) into (14)

$$\mathbf{p}_{C_1}^0 = \begin{bmatrix} 0 \\ 0 \\ r_0 \end{bmatrix}, \quad \mathbf{p}_{C_2}^0 = \begin{bmatrix} r_1 c_1 c_2 \\ r_1 s_1 c_2 \\ l_0 - r_1 s_2 \end{bmatrix}, \quad \mathbf{p}_{C_3}^0 = \begin{bmatrix} (c_2 l_1 + c_{23} r_2) c_1 \\ (c_2 l_1 + c_{23} r_2) s_1 \\ l_0 - l_1 s_2 - r_2 s_{23} \end{bmatrix}. \quad (61)$$

Substituting (61) into (24) develops the three translational Jacobian matrices

$$\mathbf{J}_{T_1}^0 = \frac{\partial \mathbf{p}_{C_1}^0}{\partial \mathbf{q}} = \begin{bmatrix} 0 & 0 & 0 \\ 0 & 0 & 0 \\ 0 & 0 & 0 \end{bmatrix}, \quad \mathbf{J}_{T_2}^0 = \frac{\partial \mathbf{p}_{C_2}^0}{\partial \mathbf{q}} = \begin{bmatrix} -s_1 c_2 r_1 & -c_1 s_2 r_1 & 0 \\ c_1 c_2 r_1 & -s_1 s_2 r_1 & 0 \\ 0 & -c_2 r_1 & 0 \end{bmatrix},$$

$$\mathbf{J}_{T_3}^0 = \frac{\partial \mathbf{p}_{C_3}^0}{\partial \mathbf{q}} = \begin{bmatrix} -s_1 (c_2 l_1 + c_{23} r_2) & -c_1 (l_1 s_2 + r_2 s_{23}) & -c_1 s_{23} r_2 \\ c_1 (c_2 l_1 + c_{23} r_2) & -s_1 (l_1 s_2 + r_2 s_{23}) & -s_1 s_{23} r_2 \\ 0 & -c_2 l_1 - c_{23} r_2 & -c_{23} r_2 \end{bmatrix}. \quad (62)$$

The generalized inertia matrix is obtained by using (28)

$$\mathbf{M} = \sum_{i=1}^3 \left(m_i (\mathbf{J}_{T_i}^0)^T \mathbf{J}_{T_i}^0 + \mathbf{J}_{R_i}^T \mathbf{I}_i \mathbf{J}_{R_i} \right) \quad (63)$$

with its elements satisfying the symmetric, positive definite properties

$$M_{11} = I_{3yy} c_{23}^2 + I_{3xx} s_{23}^2 + I_{2xx} s_2^2 + I_{1yy} + (m_2 r_1^2 + I_{2yy}) c_2^2 + m_3 (r_2 c_{23} + l_1 c_2)^2,$$

$$M_{22} = 2l_1 m_3 r_2 c_3 + (l_1^2 + r_2^2) m_3 + m_2 r_1^2 + I_{3zz} + I_{2zz}, \quad (64)$$

$$M_{33} = m_3 r_2^2 + I_{3zz}, \quad M_{12} = M_{21} = 0, \quad M_{13} = M_{31} = 0,$$

$$M_{23} = M_{32} = l_1 m_3 r_2 c_3 + m_3 r_2^2 + I_{3zz}. \quad (65)$$

The Coriolis/centrifugal matrix is obtained by substituting (63) into (52)

$$\mathbf{C} = \frac{1}{2} \left[\frac{\partial \mathbf{M}}{\partial \mathbf{q}} (\mathbf{1}_3 \otimes \dot{\mathbf{q}}) + \frac{\partial \mathbf{M}}{\partial \mathbf{q}} (\dot{\mathbf{q}} \otimes \mathbf{1}_3) - \left(\frac{\partial \mathbf{M}}{\partial \mathbf{q}} (\dot{\mathbf{q}} \otimes \mathbf{1}_3) \right)^T \right], \quad (66)$$

with its components as follows:

$$C_{11} = - \left[(m_3 r_2^2 + I_{3yy} - I_{3xx}) (\dot{q}_2 + \dot{q}_3) s_{23} + m_3 r_2 l_1 (2\dot{q}_2 + \dot{q}_3) s_2 \right] c_{23}$$

$$- (l_1^2 m_3 + m_2 r_1^2 - I_{2xx} + I_{2yy}) c_2 s_2 \dot{q}_2 - l_1 m_3 r_2 s_3 (\dot{q}_2 + \dot{q}_3),$$

$$C_{12} = - \left\{ [(m_3 r_2^2 + I_{3yy} - I_{3xx}) s_{23} + 2l_1 s_2 m_3 r_2] c_{23} \right.$$

$$\left. + (l_1^2 m_3 + m_2 r_1^2 - I_{2xx} + I_{2yy}) c_2 s_2 + l_1 m_3 r_2 s_3 \right\} \dot{q}_1,$$

$$C_{13} = - \left\{ [(m_3 r_2^2 + I_{3yy} - I_{3xx}) s_{23} + l_1 s_2 m_3 r_2] c_{23} + l_1 m_3 r_2 s_3 \right\} \dot{q}_1,$$

$$C_{21} = \left\{ [(m_3 r_2^2 + I_{3yy} - I_{3xx}) s_{23} + 2l_1 s_2 m_3 r_2] c_{23} \right.$$

$$\left. + (l_1^2 m_3 + m_2 r_1^2 - I_{2xx} + I_{2yy}) c_2 s_2 + l_1 m_3 r_2 s_3 \right\} \dot{q}_1,$$

$$C_{22} = - l_1 m_3 r_2 s_3 \dot{q}_3,$$

$$C_{23} = - l_1 m_3 r_2 s_3 (\dot{q}_2 + \dot{q}_3),$$

$$C_{31} = \left\{ [(m_3 r_2^2 + I_{3yy} - I_{3xx}) s_{23} + l_1 s_2 m_3 r_2] c_{23} + l_1 m_3 r_2 s_3 \right\} \dot{q}_1,$$

$$C_{32} = l_1 m_3 r_2 s_3 \dot{q}_2,$$

$$C_{33} = 0. \quad (67)$$

The total potential energy of the three-link manipulator is computed by substituting (61) into (17), then the vector of gravity term is yielded by applying (17) to (45)

$$P = - \sum_{i=1}^3 m_i (\mathbf{g}^0)^T \mathbf{p}_{C_i}^0 = g (l_0 m_2 + l_0 m_3 + m_1 r_0 - (l_1 m_3 + m_2 r_1) s_2 - m_3 r_2 s_{23}), \quad (68)$$

$$\mathbf{g} = \left(\frac{\partial P}{\partial \mathbf{q}} \right)^T = \begin{bmatrix} 0 \\ -(l_1 m_3 + m_2 r_1) g c_2 - m_3 r_2 g c_{23} \\ -m_3 r_2 g c_{23} \end{bmatrix}. \quad (69)$$

And finally, the skew-symmetric property of $\dot{\mathbf{M}} - 2\mathbf{C}$ can be verified obviously by considering every one of its elements as follows:

$$\begin{aligned} \dot{M}_{11} - 2C_{11} &= 0, & \dot{M}_{22} - 2C_{22} &= 0, & \dot{M}_{33} - 2C_{33} &= 0, \\ \dot{M}_{12} - 2C_{12} &= -(\dot{M}_{21} - 2C_{21}) \\ &= 2 \{ [(m_3 r_2^2 + I_{3yy} - I_{3zz}) s_{23} + 2l_1 s_2 m_3 r_2] c_{23} \\ &\quad + (l_1^2 m_3 + m_2 r_1^2 - I_{2xx} + I_{2yy}) c_{23} s_2 + l_1 m_3 r_2 s_3 \} \dot{q}_1, \\ \dot{M}_{13} - 2C_{13} &= -(\dot{M}_{31} - 2C_{31}) \\ &= 2 \{ [(m_3 r_2^2 + I_{3yy} - I_{3zz}) s_{23} + l_1 s_2 m_3 r_2] c_{23} + l_1 m_3 r_2 s_3 \} \dot{q}_1, \\ \dot{M}_{23} - 2C_{23} &= -(\dot{M}_{32} - 2C_{32}) \\ &= l_1 m_3 r_2 s_3 (2\dot{q}_2 + \dot{q}_3). \end{aligned} \quad (70)$$

The dynamic simulation of the three-link manipulator is performed by MATLAB Simscape Multibody with the followings properties:

$$\begin{aligned} \text{Link 1: } l_0 &= 0.294, \quad r_0 = 0.140, \quad m_1 = 5.248, \quad \mathbf{r}_{C_1} = \begin{bmatrix} 0 \\ 0.154 \\ 0 \end{bmatrix}, \quad \mathbf{I}_1 = \begin{bmatrix} 83.5 & 0 & 0 \\ 0 & 30.4 & 0 \\ 0 & 0 & 83.5 \end{bmatrix} 10^{-3}; \\ \text{Link 2: } l_1 &= 0.190, \quad r_1 = 0.088, \quad m_2 = 2.412, \quad \mathbf{r}_{C_2} = \begin{bmatrix} -0.102 \\ 0 \\ 0 \end{bmatrix}, \quad \mathbf{I}_2 = \begin{bmatrix} 15.9 & 0 & 0 \\ 0 & 40.5 & 0 \\ 0 & 0 & 40.5 \end{bmatrix} 10^{-3}; \\ \text{Link 3: } l_2 &= 0.170, \quad r_2 = 0.080, \quad m_3 = 1.577, \quad \mathbf{r}_{C_3} = \begin{bmatrix} -0.090 \\ 0 \\ 0 \end{bmatrix}, \quad \mathbf{I}_3 = \begin{bmatrix} 7.9 & 0 & 0 \\ 0 & 20.2 & 0 \\ 0 & 0 & 20.2 \end{bmatrix} 10^{-3}; \end{aligned} \quad (71)$$

where the units of mass, length, and inertia tensor are kg, m, and kgm^2 , respectively. The Simscape Multibody model of the manipulator is shown in Figure 3.

The proposed Coriolis/centrifugal matrix can be validated through the validation of dynamic model. One of the ways to validate a dynamic model of a system is to compare this model with another validated model of the system. Thus, the identified dynamic model of the three-link manipulator can be validated by comparing with its Simscape Multibody model that is generated and validated by MATLAB. The two mentioned model are compared by the match of responses and references under the act of the simple feedforward controller

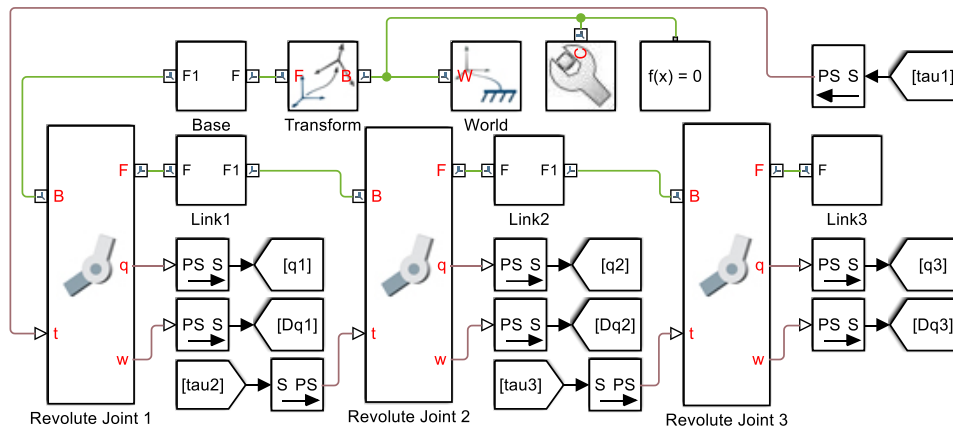

Figure 3. Simscape Multibody model of the three-link manipulator

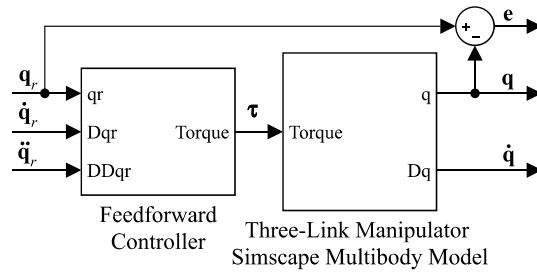

Figure 4. Feedforward control schematic for the three-link manipulator

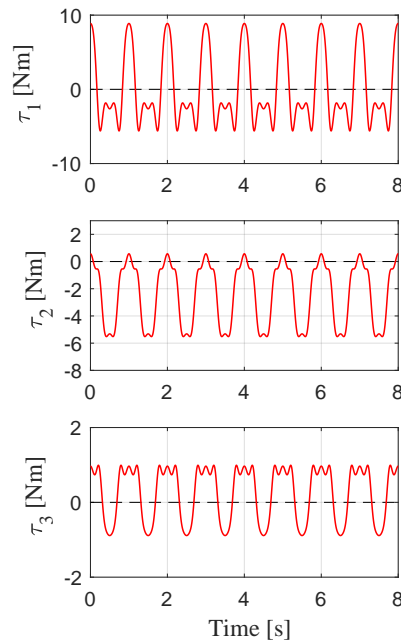

Figure 5. Input torques of the three-link manipulator

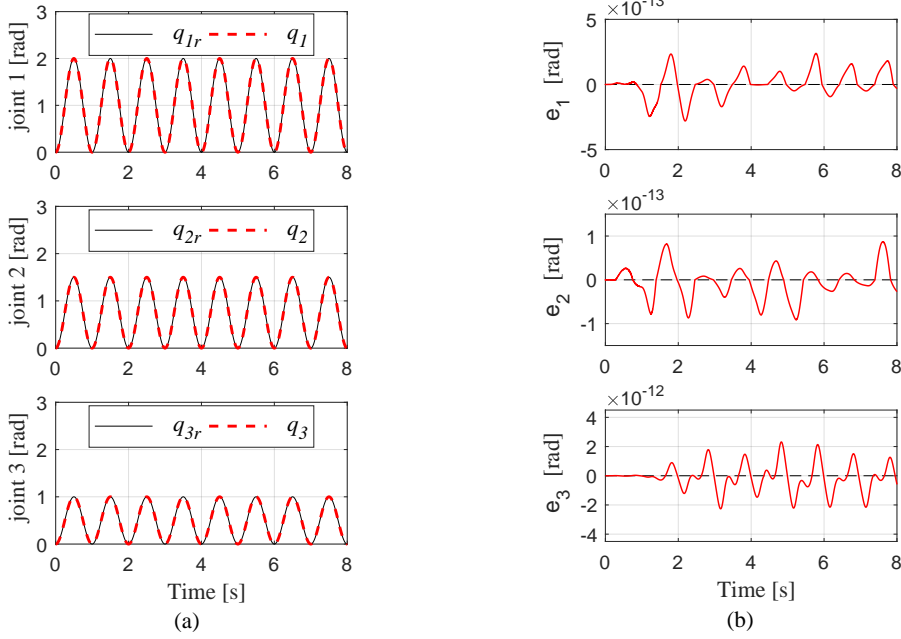

Figure 6. (a) References and responses of the three-link manipulator under the act of the feedforward controller, (b) Trajectory tracking errors

which depends completely on the accuracy of the identified model. The simulation schematic is shown in Figure 4 and the feedforward control law is given by

$$\boldsymbol{\tau} = \mathbf{M}(\mathbf{q}_r)\ddot{\mathbf{q}}_r + \mathbf{C}(\mathbf{q}_r, \dot{\mathbf{q}}_r)\dot{\mathbf{q}}_r + \mathbf{g}(\mathbf{q}_r), \quad (72)$$

where $\mathbf{q}_r = [q_{1r}, q_{2r}, q_{3r}]^T$ is the reference joint trajectory. Matrices \mathbf{M} , \mathbf{C} , and \mathbf{g} are previously obtained. With this control law, $\mathbf{q}(t) = \mathbf{q}_r(t)$ for all $t \geq 0$ if the following two conditions are satisfied. The first, the identified robot dynamic model is perfect. The second, both $\mathbf{q}_r(0) = \mathbf{q}(0)$ and $\dot{\mathbf{q}}_r(0) = \dot{\mathbf{q}}(0)$. The initial conditions of the Simscape Multibody model of the manipulator are $\mathbf{q}(0) = \mathbf{0}$ and $\dot{\mathbf{q}}(0) = \mathbf{0}$ by default. Hence, the reference trajectories, in radian, are chosen as follows for satisfying the second condition $\mathbf{q}_r(0) = \mathbf{q}(0) = \mathbf{0}$ and $\dot{\mathbf{q}}_r(0) = \dot{\mathbf{q}}(0) = \mathbf{0}$.

$$\begin{aligned} q_{1r} &= 1 - \cos(2\pi t), & \dot{q}_{1r} &= 2\pi \sin(2\pi t), \\ q_{2r} &= 0.75(1 - \cos(2\pi t)), & \dot{q}_{2r} &= 1.5\pi \sin(2\pi t), \\ q_{3r} &= 0.5(1 - \cos(2\pi t)), & \dot{q}_{3r} &= \pi \sin(2\pi t). \end{aligned} \quad (73)$$

The responses and the trajectory tracking errors are shown in Figure 6a and Figure 6b, respectively, under the act of the input torques expressed in Figure 5. From Figure 6a and Figure 6b, it is shown that the responses and the references are closely matched, for all $t \geq 0$, with slight tracking errors (not greater than 10^{-12}) caused by the numerical method of dynamic simulation used inside Simscape Multibody. Therefore, the first required condition of the feedforward control law is satisfied. This confirms that the identified model is accurate and conformable to the Simscape Multibody model. Hence, the dynamic model of the manipulator, as well as the proposal formulation of the Coriolis/centrifugal matrix, is validated.

6. CONCLUSIONS

A complete generalized procedure for building dynamic model of robot manipulators based on the Euler-Lagrange equations is presented. By using Kronecker product for the definitions about the partial derivative of matrix functions with respect to a vector variable, and time derivative of matrix functions, the Coriolis/centrifugal matrix is constructed directly in matrix-based manner. The new formulation of the Coriolis/centrifugal matrix assures the skew symmetric property of dynamic equations. It is a valuable property often used in designing control algorithms for robot manipulators. The proposed formulation is validated by symbolic solution and dynamic simulation of a typical robot manipulator. The symbolic calculations can be handled by some technical computing softwares such as Maple, Mathematica. Henceforth, this result provides a convenient way to establish the dynamic model of robot manipulators for simulation and control.

REFERENCES

- [1] J. Angeles, *Fundamentals of Robotic Mechanical Systems: Theory, Methods and Algorithms*, 3rd ed. New York, NY, USA: Springer Science+Business Media LLC, 2007.
- [2] M. Becke and T. Schlegl, "Extended Newton-Euler based centrifugal/coriolis matrix factorization for geared serial robot manipulators with ideal joints," in *Proceedings of 15th International Conference Mechatronika*. Prague, Czech Republic: IEEE, Dec. 2012, pp. 1–7.
- [3] M. Bjerkgang and K. Y. Pettersen, "A new Coriolis matrix factorization," in *IEEE International Conference on Robotics and Automation*, Saint Paul, MN, USA, may 2012, pp. 4974–4979.
- [4] J. Brewer, "Kronecker products and matrix calculus in system theory," *IEEE Transactions on Circuits and Systems*, vol. 25, no. 9, pp. 772–781, 1978.
- [5] P. T. Cat, "Robust cartesian control of n -dof manipulator with dynamic and jacobian uncertainties," *Journal of Computer Science and Cybernetics*, vol. 24, no. 4, pp. 333–341, 2008 (Vietnamese).
- [6] E. Dombre and W. Khalil, Eds., *Modeling, Performance Analysis and Control of Robot Manipulators*. London, UK: ISTE Ltd, 2007.
- [7] N. T. Hiep and P. T. Cat, "Robust sliding mode control of manipulator using neural network," *Journal of Computer Science and Cybernetics*, vol. 24, no. 3, pp. 236–246, 2008 (Vietnamese).
- [8] N. Q. Hoang and V. D. Vuong, "Sliding mode control for a planar parallel robot driven by electric motors in a task space," *Journal of Computer Science and Cybernetics*, vol. 33, no. 4, pp. 325–337, 2017.
- [9] Hong-Chin Lin, Tsung-Chieh Lin, and K. Yae, "On the skew-symmetric property of the Newton-Euler formulation for open-chain robot manipulators," in *Proceedings of 1995 American Control Conference - ACC'95*, vol. 3. Seattle, WA, USA: IEEE, Jun 1995, pp. 2322–2326.
- [10] A. J. Laub, *Matrix Analysis for Scientists and Engineers*. Philadelphia, PA, USA: SIAM, 2005.
- [11] N. V. Khang, "Consistent definition of partial derivatives of matrix functions in dynamics of mechanical systems," *Mechanism and Machine Theory*, vol. 45, no. 7, pp. 981–988, 2010.

- [12] —, “Kronecker product and a new matrix form of Lagrangian equations with multipliers for constrained multibody systems,” *Mech. Res. Commun.*, vol. 38, no. 4, pp. 294–299, 2011.
- [13] N. V. Khang, N. Q. Hoang, N. D. Sang, and N. D. Dung, “A comparison study of some control methods for delta spatial parallel robot,” *Journal of Computer Science and Cybernetics*, vol. 31, no. 1, pp. 71–81, 2015.
- [14] N. V. Khang and T. Q. Trung, “Motion control of biped robots in single support phase based on neural network sliding mode approach,” *Journal of Computer Science and Cybernetics*, vol. 30, no. 1, pp. 70–80, 2014 (Vietnamese).
- [15] F. L. Lewis, D. M. Dawson, and C. T. Abdallah, *Robot Manipulator Control: Theory and Practice*, 2nd ed. New York, NY, USA: Marcel Dekker, 2004.
- [16] R. M. Murray, Z. Li, and S. S. Sastry, *A Mathematical Introduction to Robotic Manipulation*. Boca Raton, FL, USA: CRC Press, 1994.
- [17] S. R. Ploen, “A skew-symmetric form of the recursive Newton-Euler algorithm for the control of multibody systems,” in *Proc. of ACC*, vol. 6, San Diego, CA, USA, jun 1999, pp. 3770–3773.
- [18] P. Sánchez-Sánchez and M. A. Arteaga-Pérez, “Simplified methodology for obtaining the dynamic model of robot manipulators,” *Int. J. Adv. Robot. Syst.*, vol. 9, no. 5, pp. 1–12, 2012.
- [19] L. Sciavicco and B. Siciliano, *Modelling and Control of Robot Manipulators*, 2nd ed., ser. Advanced Textbooks in Control and Signal Processing. London, UK: Springer London, 2000.
- [20] B. Siciliano, L. Sciavicco, L. Villani, and G. Oriolo, *Robotics: Modelling, Planning and Control*. London, UK: Springer London, 2009.
- [21] M. W. Spong, S. Hutchinson, and V. M., *Robot Modeling and Control*, 1st ed. Hoboken, NJ, USA: John Wiley & Sons, 2006.
- [22] F. Zhang, *Matrix Theory*, 2nd ed., ser. Universitext. NY: Springer New York, 2011.

Received on October 29, 2019
Revised on November 27, 2019