

Output regulation for linear discrete-time systems subject to input saturation

Citation for published version (APA):

Mantri, R., Saberi, A., Lin, Z., & Stoorvogel, A. A. (1995). *Output regulation for linear discrete-time systems subject to input saturation*. (Memorandum COSOR; Vol. 9505). Technische Universiteit Eindhoven.

Document status and date:

Published: 01/01/1995

Document Version:

Publisher's PDF, also known as Version of Record (includes final page, issue and volume numbers)

Please check the document version of this publication:

- A submitted manuscript is the version of the article upon submission and before peer-review. There can be important differences between the submitted version and the official published version of record. People interested in the research are advised to contact the author for the final version of the publication, or visit the DOI to the publisher's website.
- The final author version and the galley proof are versions of the publication after peer review.
- The final published version features the final layout of the paper including the volume, issue and page numbers.

[Link to publication](#)

General rights

Copyright and moral rights for the publications made accessible in the public portal are retained by the authors and/or other copyright owners and it is a condition of accessing publications that users recognise and abide by the legal requirements associated with these rights.

- Users may download and print one copy of any publication from the public portal for the purpose of private study or research.
- You may not further distribute the material or use it for any profit-making activity or commercial gain
- You may freely distribute the URL identifying the publication in the public portal.

If the publication is distributed under the terms of Article 25fa of the Dutch Copyright Act, indicated by the "Taverne" license above, please follow below link for the End User Agreement:

www.tue.nl/taverne

Take down policy

If you believe that this document breaches copyright please contact us at:

openaccess@tue.nl

providing details and we will investigate your claim.

Output Regulation for Linear Discrete-Time Systems Subject to Input Saturation

Ravi Mantri & Ali Saberi
School of Electrical Engineering
and Computer Science
Washington State University
Pullman, WA 99164-2752
U.S.A.

Zongli Lin
Dept. of Applied Mathematics
and Statistics
SUNY at Stony Brook
Stony Brook, NY 11794-3600
U.S.A.

Anton A. Stoorvogel
Dept. of Mathematics
and Computing Science
Eindhoven Univ. of Technology
P.O. Box 513, 5600 MB Eindhoven
The Netherlands

July 26, 1995

Abstract

The purpose of this paper is to examine the problem of controlling a linear discrete-time system subject to input saturation in order to have its output track (or reject) a family of reference (or disturbance) signals produced by some external generator. It is shown that a semi-global framework, rather than a global framework, for this problem is a natural one. Within this framework, a set of solvability conditions are given and feedback laws which solve the problem are constructed. The theory developed in this paper parallels the one we developed earlier for the continuous-time system [10].

1. Introduction

Recently there has been a surge of interest in the study of linear systems subject to input saturation due to a wide recognition of the inherent constraints on the control actuator. Although most of the results in this study pertain to the problem of global stabilization (see, for example, [2], [12], [14], [16], [15]) and semi-global stabilization (see, for example, [6], [7], [8], [9], [18], [11]), some attempts have also been made in the solution of output regulation problems for *continuous-time* systems. Roughly speaking, this problem is one of controlling a linear system subject to input saturation in order to have its output track (or reject) a family of reference (or disturbance) signals generated by some external system, usually called the exosystem. The control laws that solve the output regulation problems are referred to as regulators. A global output regulation problem results if tracking and disturbance rejection is required to occur for all initial conditions of the closed-loop system, while a semi-global output regulation problem results if tracking and disturbance rejection is only required to occur when the initial conditions of the closed-loop system are inside an a priori given (arbitrarily large) bounded set of the state space. The global output regulation problem and semi-global output regulation problem for linear continuous-time systems subject to input saturation were first studied in [17] and [10] respectively. Moreover, an improved design for semi-global regulators which achieve better performance was later proposed in [5]. Although the global output regulation is appealing by definition, the semi-global output regulation, as shown in [10], is achievable for a much larger class of systems and allows for linear feedbacks.

This paper deals with semi-global output regulation problem for linear discrete-time systems subject to input saturation and presents results parallel to those in its continuous counterpart ([10]). It reflects the continuation of the study of semi-global output regulation problem for linear systems subject to input saturation which began in [10]. More specifically, we study the semi-global output regulation problem for linear discrete-time systems subject to input saturation which are asymptotically null controllable with bounded controls¹. The rationale behind the adoption of a semi-global framework for output regulation problem is two-fold. Firstly, the semi-global framework allows us to use linear feedback laws, which is obviously very appealing; and secondly, the semi-global framework seems to be a natural choice when we show that the global output regulation problem, in general, does not have a solution. We will study both the state feedback and the error feedback case. The dynamic error feedback regulator problem is solved by designing a linear observer based feedback. In this case, although the controller has a linear structure, it has some nonlinearity due to input saturation. We introduce the notion of semi-global output regulation problems by extending the output regulator theory for linear systems in the absence of input saturation developed by several authors (e.g. [1] and [19]) to linear systems subject to input saturation which are asymptotically null controllable with bounded controls. A set of solvability conditions for these problems is provided and it is shown that for a fairly general class of systems these conditions are necessary. We also show that, under certain weak assumptions, these solvability conditions for semi-global regulator problems cannot be weakened further even if we resort to nonlinear feedback laws. However, by example, we show that there are

¹A linear discrete-time system is said to be asymptotically null controllable with bounded controls if and only if it is stabilizable and all its open loop system poles are inside or on the unit circle.

cases where a nonlinear feedback can do better. Finally, in an effort to broaden the class of disturbance and reference signals, we formulate and solve the generalized semi-global linear feedback regulator problem, for which an external driving signal to the exosystem is included. A crucial component in the design of the regulators in this paper is the low gain design techniques developed in [4], [6] and [11]. For this reason, we briefly recall the ARE-based low gain design algorithm from [11]. For the sake of completeness and to facilitate comparison, the regulator theory for linear systems in the absence of input saturation is briefly reviewed in the discrete-time language.

We will mostly use standard notation in this paper. However, we have denoted the shift operator by a superscript $+$, i.e. $x^+(k) = x(k+1)$. For a vector $q = (q_1, q_2, \dots, q_n)^T$ we define

$$|q|_\infty := \max_i |q_i|$$

On the other hand, for a vector-valued function w and $K \geq 0$ we define

$$\|w\|_\infty := \sup_k |w(k)|_\infty, \quad \|w\|_{\infty, K} := \sup_{k \geq K} |w(k)|_\infty$$

Finally $\|\cdot\|$ denotes the standard Euclidean norm.

2. Preliminaries

This section consists of two subsections. In the first subsection, we briefly review the linear multivariable regulator theory in the discrete-time setting, while in the second subsection, we recall an ARE-based low gain design for linear discrete-time systems.

2.1. Review of Linear Regulator Theory

In this subsection, we briefly review the linear multivariable regulator theory in the discrete-time language. Consider a multivariable linear discrete-time system as given below,

$$\begin{cases} x^+ &= Ax + Bu + Pw \\ w^+ &= Sw \\ e &= Cx + Qw \end{cases} \quad (2.1)$$

where and elsewhere, for notational brevity, we suppress the time index k . The first equation of this system describes a plant, with state $x \in \mathbb{R}^n$, and input $u \in \mathbb{R}^m$, subject to the effect of a *disturbance* represented by Pw . The third equation defines the error $e \in \mathbb{R}^p$ between the actual plant output Cx and a *reference* signal $-Qw$ which the plant output is required to track. The second equation describes an autonomous system, often called the *exosystem*, with state $w \in \mathbb{R}^s$. The exosystem models the class of disturbance or reference signals taken into consideration.

The control action to the plant, u , can be provided either by state feedback or by error feedback. A *state feedback controller* has the form

$$u = Fx + Gw \quad (2.2)$$

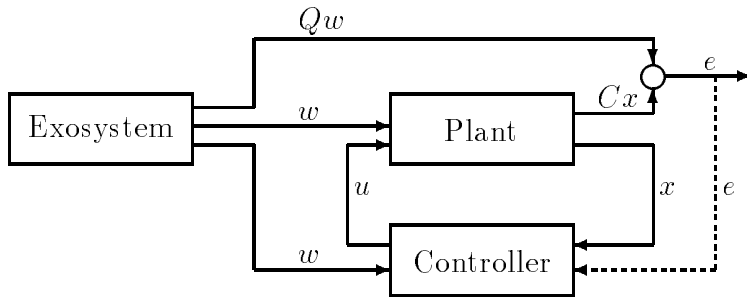

Figure 2.1: Configuration of a linear regulator

Composing (2.1) and (2.2) yields a closed-loop system

$$\begin{cases} x^+ &= (A + BF)x + (P + BG)w, \\ w^+ &= Sw \\ e &= Cx + Qw \end{cases} \quad (2.3)$$

An *error feedback controller* has the form

$$\begin{cases} z^+ &= A_c z + B_c e, \quad z \in \mathbb{R}^l \\ u &= C_c z + D_c e \end{cases} \quad (2.4)$$

The interconnection of (2.1) and (2.4) yields a closed-loop system

$$\begin{cases} x^+ &= (A + BD_c C)x + BC_c z + (P + BD_c Q)w \\ z^+ &= A_c z + B_c Cx + B_c Qw \\ w^+ &= Sw \\ e &= Cx + Qw \end{cases} \quad (2.5)$$

The purpose of the control action is to achieve internal stability and output regulation. Internal stability means that, when the exosystem is disconnected (i.e., when w is set equal to 0), the closed-loop (2.3) [respectively, (2.5)] is asymptotically stable. Output regulation means that for the closed-loop system (2.3) [respectively, (2.5)] and for all initial conditions $(x(0), w(0))$ [respectively, $(x(0), z(0), w(0))$], we have $e(k) \rightarrow 0$ as $k \rightarrow \infty$. Formally, all of this can be summarized in the following two synthesis problems.

Problem 2.1: The state feedback regulator problem for the linear discrete-time systems (2.1) is to find, if possible, a state feedback law of the form (2.2) such that

1. The system $x^+ = (A + BF)x$ is asymptotically stable;
2. For all $(x(0), w(0)) \in \mathbb{R}^{n+s}$, the solution of (2.3) satisfies $\lim_{k \rightarrow \infty} e(k) = 0$.

Problem 2.2: The error feedback regulator problem for the linear discrete-time systems (2.1) is to find, if possible, an error feedback law of the form (2.4) such that

1. The system

$$\begin{cases} x^+ &= (A + BD_c C)x + BC_c z \\ z^+ &= A_c z + B_c Cx \end{cases}$$

is asymptotically stable;

2. For all $(x(0), z(0), w(0)) \in \mathbb{R}^{n+l+s}$, the solution of (2.5) satisfies $\lim_{k \rightarrow \infty} e(k) = 0$.

The solution of these two problems (see [1]) is based on the following three assumptions:

A1. The eigenvalues of S are on or outside the unit circle.

A2. The pair (A, B) is stabilizable.

A3. The pair $([C \ Q], \begin{bmatrix} A & P \\ 0 & S \end{bmatrix})$ is detectable.

The first one of these assumptions does not involve a loss of generality because asymptotically stable modes in the exosystem do not affect the regulation of the output. The second one is indeed necessary for asymptotic stabilization of the closed loop via either state or error feedback. The third one is stronger than the assumption of detectability of the pair (C, A) , that would be necessary for the asymptotic stabilization of the closed loop via error feedback, but again does not involve loss of generality, as discussed in detail by Francis in [1]. In fact, if the pair (C, A) is detectable and A3 does not hold, it is always possible to reduce the dimension of the exosystem which actually affects the error, and have – on the reduced system thus obtained – condition A3 satisfied.

The following two theorems are the discrete-time versions of the continuous-time results of Francis ([1]) and describe the necessary and sufficient conditions for the existence of solutions to the above two problems.

Theorem 2.3: *Suppose assumptions A1 and A2 hold. Then, the linear state feedback regulator problem is solvable if and only if there exist matrices Π and Γ which solve the linear matrix equations*

$$\begin{cases} \Pi S = A\Pi + B\Gamma + P \\ C\Pi + Q = 0 \end{cases} \quad (2.6)$$

Moreover, a suitable state feedback is given by:

$$u = -Fx + (F\Pi + \Gamma)w \quad (2.7)$$

where F is such that $A - BF$ is Schur stable.

Theorem 2.4: *Suppose assumptions A1, A2 and A3 hold. Then, the linear error feedback regulator problem is solvable if and only if there exist matrices Π and Γ which solve the linear matrix equations (2.6).*

Moreover, a suitable error feedback is given by:

$$\begin{cases} \begin{bmatrix} \hat{x}^+ \\ \hat{w}^+ \end{bmatrix} = \begin{bmatrix} A & P \\ 0 & S \end{bmatrix} \begin{bmatrix} \hat{x} \\ \hat{w} \end{bmatrix} + \begin{bmatrix} B \\ 0 \end{bmatrix} u + \begin{bmatrix} L_A \\ L_S \end{bmatrix} (e - [C \ Q] \begin{bmatrix} \hat{x} \\ \hat{w} \end{bmatrix}) \\ u = -F\hat{x} + (F\Pi + \Gamma)\hat{w} \end{cases} \quad (2.8)$$

where F is such that $A - BF$ is Schur stable and L_A and L_S are such that the matrix

$$\bar{A} := \begin{bmatrix} A - L_A C & P - L_A Q \\ -L_S C & S - L_S Q \end{bmatrix}$$

is Schur stable.

In summary, if assumptions A1, A2 and A3 hold, then, the linear error feedback regulator problem is solvable if and only if the state feedback regulator problem is solvable, and the conditions for the existence of solutions can be expressed in terms of the solvability of certain linear matrix equations.

In [3], Hautus has proven that the possibility of solving these matrix equations can be characterized in terms of a comparison between the transmission polynomials of the system (2.1) (in which u is considered as the input and e as the output) and those of the system

$$\begin{cases} x^+ &= Ax + Bu \\ e &= Cx \end{cases} \quad (2.9)$$

The latter can be interpreted as the system obtained from (2.1) by cutting the connections between the exosystem and the plant. More specifically, Hautus proved the following result.

Proposition 2.5: *The linear matrix equations (2.6) are solvable if and only if the system (2.1) and (2.9) have the same transmission polynomials.*

2.2. Review of ARE-Based Low Gain Design for Discrete-time Linear Systems

In this subsection, we recall an algebraic Riccati equation (ARE) and some of its properties from [11]. This ARE leads to the ARE-based low gain design as given in [11] and will be instrumental in obtaining the regulator design of this paper.

Consider the linear system

$$x^+ = Ax + Bu, \quad (2.10)$$

and an associated ARE

$$X = A'XA + \varepsilon I - A'XB(B'XB + I)^{-1}B'XA, \quad \varepsilon > 0 \quad (2.11)$$

We now recall the following lemmas regarding the properties of the ARE (2.11) from [11].

Lemma 2.6: *Assume that (A, B) is stabilizable and all the eigenvalues of A are located inside or on the unit circle. Then, for any $\varepsilon > 0$, there exists a unique matrix $X(\varepsilon) > 0$ which solves the algebraic Riccati equation (2.11) and is such that $A - B(B'X(\varepsilon)B + I)^{-1}B'X(\varepsilon)A$ is Schur stable. Moreover,*

$$\lim_{\varepsilon \rightarrow 0} X(\varepsilon) = 0 \quad (2.12)$$

Lemma 2.7: *Assume that (A, B) is stabilizable and all the eigenvalues of A are located inside or on the unit circle. Then, there exists an $\varepsilon^* > 0$ such that, for $\varepsilon \in (0, \varepsilon^*]$,*

$$\|X^{\frac{1}{2}}(\varepsilon)AX^{-\frac{1}{2}}(\varepsilon)\| \leq \sqrt{2} \quad (2.13)$$

3. Global Regulator Problem for Linear Discrete-Time Systems Subject to Input Saturation

In this section, we consider the regulator problem when the plant inputs are subject to saturation. More specifically, we consider a linear discrete-time multivariable system with inputs that are subject to saturation together with an exosystem that generates disturbance and reference signals as described by the following system

$$\begin{cases} x^+ &= Ax + B\sigma(u) + Pw \\ w^+ &= Sw \\ e &= Cx + Qw \end{cases} \quad (3.1)$$

where $x \in \mathbb{R}^n$, $w \in \mathbb{R}^s$, $u \in \mathbb{R}^m$, $e \in \mathbb{R}^p$, and σ is a vector-valued saturation function defined as

$$\sigma(s) = [\sigma_1(s_1), \sigma_2(s_2), \dots, \sigma_m(s_m)]' \quad (3.2)$$

with

$$\sigma_i(s_i) = \begin{cases} s_i & \text{if } |s_i| \leq 1 \\ -1 & \text{if } s_i < -1 \\ 1 & \text{if } s_i > 1 \end{cases} \quad (3.3)$$

Because of the presence of the saturation function σ , the system (3.3) is nonlinear. Note that we can also treat different saturation levels, even differences between channels, by simple scaling. The global regulator problem for continuous-time systems was first formulated by Teel in [17]. More specifically, Teel's formulation of the global state feedback regulator problem and the global error feedback regulator problem, translated into the discrete-time language, are as follows.

Problem 3.1: The global state feedback regulator problem for the linear discrete-time systems subject to input saturation (3.1) is to find, if possible, a feedback $u = \alpha(x, w)$ such that

1. The equilibrium $x = 0$ of

$$x^+ = Ax + B\sigma(\alpha(x, 0))$$

is globally asymptotically stable;

2. For all $(x(0), w(0)) \in \mathbb{R}^{n+s}$, the solution of the closed-loop system satisfies

$$\lim_{k \rightarrow \infty} e(k) = 0.$$

Problem 3.2: The global error feedback regulator problem for the linear discrete-time system subject to input saturation (3.1) is to find, if possible, a dynamic error feedback $u = \theta(z)$, $z^+ = \eta(z, e)$ where $z \in \mathbb{R}^l$ such that

1. The equilibrium $(x, z) = (0, 0)$ of

$$\begin{cases} x^+ = Ax + B\sigma(\theta(z)) \\ z^+ = \eta(z, Cx) \end{cases}$$

is globally asymptotically stable;

2. For all $(x(0), z(0), w(0)) \in \mathbb{R}^{n+l+s}$, the solution of the closed-loop system satisfies

$$\lim_{k \rightarrow \infty} e(k) = 0.$$

A set of sufficient conditions for the above global regulator problems for continuous-time systems, to have a solution are given in [17]. This set of sufficient conditions, obviously, include the necessary and sufficient conditions for global stabilization of the plant in the presence of input saturation as established by Yang ([20]), i.e., (A, B) is stabilizable and all the eigenvalues of A are inside or on the unit circle.

The global regulation as defined above is clearly a very desirable property. Unfortunately it turns out that we can achieve global regulation only under very special circumstances. In fact, the global error feedback regulator problem as formulated in Problem 3.2 basically has no solution. This is established in the following lemma.

Lemma 3.3: *Suppose assumptions A1, A2 and A3 hold. Also assume that all the eigenvalues of A are inside or on the unit circle. Then there exist initial conditions w_0 for w such that there exists no input u or initial condition $x(0)$ for which the closed-loop system satisfies $\lim_{k \rightarrow \infty} e(k) = 0$.*

Proof : We study the system (3.1) without the saturation element, i.e. we have the following system:

$$\begin{cases} x^+ &= Ax + Bv + Pw \\ w^+ &= Sw \\ e &= Cx + Qw \end{cases} \quad (3.4)$$

Let w_0 with $\|w_0\| = 1$ be an eigenvector corresponding to an eigenvalue λ of S .

Suppose λ is an eigenvalue with absolute value greater than one. We can decompose e in three components. One due to the possibly non-zero initial condition x_0 , one due to the bounded input v and one due to the initial condition w_0 . The first two can only grow polynomially in time since all eigenvalues of A are inside or on the unit circle. On the other hand the effect of w_0 will, due to detectability assumption A3, grow exponentially in time. Therefore e will also grow exponentially in time and we cannot achieve regulation.

If the absolute value of λ is not greater than one, then by assumption A1, it must lie on the unit circle. In that case, w will be bounded since $w(k) = \lambda^k w_0$. Moreover for any natural number K , and $\varepsilon > 0$ there exists $k > K$ such that $\|w(k) - w(0)\| < \varepsilon$.

We define the minimal amplitude of an input signal which achieves tracking and minimize this over all possible initial conditions of the plant:

$$\mathcal{J}(w_0) := \inf_{v, x_0} \{ \|v\|_\infty \mid v \text{ is such that } \lim_{k \rightarrow \infty} e(k) = 0 \text{ where } x(0) = x_0 \text{ and } w(0) = w_0 \}$$

Suppose $\mathcal{J}(w_0) = 0$. We take a minimizing sequence $\{v_i, x_{0,i}\}$ for the above optimization problem. For each v_i there exists a K_i such that $\|e(K_i + k)\| < 1/i$ for all $k > 0$ and $\|w(K_i) - w_0\| < 1/i$. Define

$$\bar{v}_i(k) := v_i(K_i + k)$$

Then $\|\bar{v}_i\|_\infty \leq \|v_i\|_\infty \rightarrow 0$ as $i \rightarrow \infty$. The output \bar{e}_i resulting from input \bar{v}_i and initial conditions

$$\bar{x}(0) = \bar{x}_{0,i} := x(K_i)$$

and $\bar{w}_i(0) = w(K_i)$ satisfies $\|\bar{e}_i\|_\infty < 1/i$. The latter is straightforward since $\bar{e}_i(k) = e(K_i+k)$.

Pick any integer $K > 0$. On $[0, K]$ the input \bar{v}_i converges in L_∞ norm to 0. Similarly \bar{e}_i converges to 0 uniformly on $[0, K]$. Finally $\bar{w}_i(0)$ converges to w_0 .

Define $f : \mathbb{R}^n \rightarrow L_\infty[0, K]$ by $[f(z)](k) = CA^kz$. We can check that $g \in L_\infty[0, K]$ is in the closure of the image of f where

$$g(k) := \sum_{\kappa=0}^{k-1} CA^{(k-1-\kappa)}Pw(\kappa) + Qw(k)$$

Since f is a finite rank operator we know the image is closed and hence g is in the image of f , i.e. there exists an \tilde{x}_0 such that $f(\tilde{x}_0) = -g$. We find:

$$\begin{bmatrix} C & Q \end{bmatrix} \begin{bmatrix} A & P \\ 0 & S \end{bmatrix}^k \begin{bmatrix} \tilde{x}_0 \\ w_0 \end{bmatrix} = 0 \quad (3.5)$$

for $k \in [0, K]$. This immediately implies that (3.5) holds for all k . On the other hand $w(k) \not\rightarrow 0$ as $k \rightarrow \infty$. However this contradicts the detectability assumption A3. Therefore we have $\mathcal{J}(w_0) > 0$.

Hence we find that for $w(0) = 2w_0/\mathcal{J}(w_0)$ any input v which achieves regulation satisfies $\|v\|_\infty \geq 2$. Therefore $v = \sigma(u)$ will never be able to achieve regulation, i.e. no input u to (3.1) exists for which $e(k) \rightarrow 0$ as $k \rightarrow \infty$.

The above involves complex inputs. By working with the real or complex part of the signals we can avoid this technical problem. ■

Remark 3.4: *Assumptions A2 and A3 as well as the requirement that all eigenvalues of A are inside or on the unit circle are clearly necessary for the solvability of the regulator problem using error feedback for a system with input saturation. Only assumption A1 is not strictly necessary. However, using the above lemma it is easy to derive that the global regulator problem with error feedback is solvable only if assumptions A2 and A3 are satisfied, S is Schur stable, and all eigenvalues of A are inside or on the unit circle. This means that w converges to zero and any globally stabilizing controller for the plant will solve the regulator problem. Hence the global error feedback regulator problem only has a solution if the regulation requirement is an empty requirement.*

Remark 3.5: *There are cases where the global state feedback regulator problem is solvable. However, it is necessary that the set of linear equations*

$$\begin{cases} \Pi S = A\Pi + P \\ C\Pi + Q = 0 \end{cases} \quad (3.6)$$

is solvable. Since there are more equations than unknowns it is obvious that the state feedback regulator problem is solvable only in a few special cases.

The above clearly yields a good argument to restrict attention to initial conditions $w(0)$ inside a given compact set. However, in the theory of stabilization of linear discrete-time systems subject to saturation, the step from global initial conditions to initial conditions

inside a compact set has already been made. This has been named semi-global stabilization. Since, in most cases, we have to restrict attention to initial conditions for w inside a compact set anyway this yields good motivation to direct our attention to a semi-global setting. Of course this also yields the well-known advantage that we can achieve regulation with linear compensators. Hence all the problems in this paper are solved in a semi-global setting.

4. Semi-Global Regulator Problem for Linear Discrete-time Systems Subject to Input Saturation

We split this section into three parts. In the first part we solve the semi-global linear state feedback regulator problem where all signals are available for feedback and it suffices to look at static feedbacks. In the second part we solve the semi-global error feedback regulator problem where only the error signal is available for feedback, by designing a linear observer based controller.

4.1. Linear Static State Feedback

The semi-global linear state feedback regulator problem can be formulated as follows.

Problem 4.1: Consider the system (3.1) and a compact set $\mathcal{W}_0 \subset \mathbb{R}^s$. The semi-global linear state feedback regulator problem is defined as follows.

For any a priori given (arbitrarily large) bounded set $\mathcal{X}_0 \subset \mathbb{R}^n$, find, if possible, a linear static feedback law $u = Fx + Gw$ such that

1. The equilibrium $x = 0$ of

$$x^+ = Ax + B\sigma(Fx) \quad (4.1)$$

is asymptotically stable with \mathcal{X}_0 contained in its basin of attraction;

2. For all $x(0) \in \mathcal{X}_0$ and $w(0) \in \mathcal{W}_0$, the solution of the closed-loop system satisfies

$$\lim_{k \rightarrow \infty} e(k) = 0. \quad (4.2)$$

Remark 4.2: We would like to emphasize that our definition of semi-global linear state feedback regulator problem does not view the set of initial conditions of the plant as given data. The set of given data consists of the models of the plant and the exosystem and the set of initial conditions for the exosystem. Therefore, any solvability conditions we obtain must be independent of the set of initial conditions of the plant, \mathcal{X}_0 .

The solvability conditions for semi-global linear state feedback regulator problem are given in the following theorem.

Theorem 4.3: Consider the system (3.1) and the given compact set $\mathcal{W}_0 \subset \mathbb{R}^s$. The semi-global linear state feedback regulator problem is solvable if

1. (A, B) is stabilizable and A has all eigenvalues inside or on the unit circle;

2. There exist matrices Π and Γ such that:

(a) They solve the following linear matrix equations :

$$\begin{cases} \Pi S = A\Pi + B\Gamma + P \\ C\Pi + Q = 0 \end{cases} \quad (4.3)$$

(b) There exist a $\delta > 0$ and a $K \geq 0$ such that $\|\Gamma w\|_{\infty, K} \leq 1 - \delta$ for all w with $w(0) \in \mathcal{W}_0$.

Proof : We prove this theorem by first explicitly constructing a family of linear static state feedback laws, parameterized in ε , and then showing that for each given set \mathcal{X}_0 , there exists an $\varepsilon^* > 0$ such that for all $\varepsilon \in (0, \varepsilon^*]$, both items 1 and 2 of Problem 4.1 hold. The family of linear static state feedback laws we construct takes the following form

$$u = -F(\varepsilon)x + (F(\varepsilon)\Pi + \Gamma)w \quad (4.4)$$

where $F(\varepsilon) := (B'X(\varepsilon)B + I)^{-1}B'X(\varepsilon)A$ with $X(\varepsilon)$ being the solution of the ARE (2.11). It then follows from Lemma 2.6 that $A - BF(\varepsilon)$ is Schur stable for all $\varepsilon > 0$. With this family of feedback laws, the system (4.1) is written as

$$x^+ = Ax + B\sigma(-F(\varepsilon)x) \quad (4.5)$$

The fact that there exists an $\varepsilon_1^* > 0$ such that for all $\varepsilon \in (0, \varepsilon_1^*]$, the equilibrium $x = 0$ of (4.5) is asymptotically stable with \mathcal{X}_0 contained in its basin of attraction has been established in [11]. Next, we show that there exists an $\varepsilon_2^* \in (0, 1]$ such that for each $\varepsilon \in (0, \varepsilon_2^*]$, item 2 of the theorem holds.

To this end, let us introduce an invertible, triangular coordinate change $\xi = x - \Pi w$. Using condition 2(a), we have

$$\begin{aligned} \xi^+ &= x^+ - \Pi w^+ \\ &= Ax + B\sigma(u) + Pw - \Pi Sw \\ &= A\xi + B[\sigma(u) - \Gamma w] \end{aligned} \quad (4.6)$$

With the family of state feedback laws given above, the closed-loop system can be written as

$$\xi^+ = A\xi + B[\sigma(\Gamma w - F(\varepsilon)\xi) - \Gamma w] \quad (4.7)$$

By Condition 2(b), $\|\Gamma w\|_{\infty, K} < 1 - \delta$. Moreover, for any $x(0) \in \mathcal{X}_0$ and any $w(0) \in \mathcal{W}_0$, $\xi(K)$ belongs to a bounded set, say \mathcal{U}_K , independent of ε since \mathcal{X}_0 and \mathcal{W}_0 are both bounded and $\xi(K)$ is determined by a linear difference equation with bounded inputs $\sigma(\cdot)$ and Γw .

It follows from (2.11) that

$$(A - BF(\varepsilon))'X(A - BF(\varepsilon)) - X = -\varepsilon I - F(\varepsilon)'F(\varepsilon) \quad (4.8)$$

We then pick a Lyapunov function

$$V(\xi) = \xi'X(\varepsilon)\xi \quad (4.9)$$

and let $c > 0$ be such that

$$c \geq \sup_{\xi \in \mathcal{U}_K, \varepsilon \in (0,1]} \xi' X(\varepsilon) \xi \quad (4.10)$$

Such a c exists since $X(\varepsilon)$ and \mathcal{U}_K are bounded. Let $\varepsilon_2^* \in (0, 1]$ be such that $\xi \in L_V(c)$ implies that $|F(\varepsilon)\xi|_\infty \leq \delta$ where

$$L_V(c) := \{ \xi \in \mathbb{R}^n \mid V(\xi) < c \}$$

The existence of such an ε_2^* is again due to Lemma 2.7 and the fact that $\lim_{\varepsilon \rightarrow 0} X(\varepsilon) = 0$. Hence for $k \geq K$, for all $\xi \in L_V(c)$, (4.7) takes the form

$$\xi^+ = A\xi - BF(\varepsilon)\xi \quad (4.11)$$

The evaluation of the difference of V , $k \geq K$, inside the set $L_V(c)$, using (4.8), now shows that for all $\xi \in L_V(c)$,

$$V(\xi^+) - V(\xi) = -\xi' (\varepsilon I + F(\varepsilon)'F(\varepsilon)) \xi. \quad (4.12)$$

This shows that any trajectory of (4.7) starting at $k = 0$ from $\{ \xi = x - \Pi w : x \in \mathcal{X}_0, w \in \mathcal{W}_0 \}$ remains inside the set $L_V(c)$ and approaches the equilibrium $\xi = 0$ as $k \rightarrow \infty$, which implies that $e = C\xi \rightarrow 0$ as $k \rightarrow \infty$.

Finally, setting $\varepsilon^* = \min\{\varepsilon_1^*, \varepsilon_2^*\}$, we conclude our proof of Theorem 4.3. ■

Remark 4.4: *In view of Yang's results ([20]) and the solvability conditions for the state feedback output regulator problem for linear systems in the absence of input saturation as given by Theorem 2.3, it is obvious to observe that Conditions 1 and 2(a) of Theorem 4.3 are necessary. The crucial condition for the solvability of this semi-global linear state feedback regulator problem is Condition 2(b), which is a sufficient condition. In section 5 we will discuss the necessity of Condition 2(b).*

It is interesting to observe that if $\Gamma w = 0$, then Condition 2(b) of Theorem 4.3 is automatically satisfied. The following lemma examines the cases for which $\Gamma w = 0$ holds.

Lemma 4.5: *Consider Condition 2(b) of Theorem 4.3. $\Gamma w = 0$ for all $w(0) \in \mathcal{W}_0$ if and only if $\mathcal{W}_0 \subset \langle \ker \Gamma \mid S \rangle$, where $\langle \ker \Gamma \mid S \rangle$ is the unobservable subspace of the pair (S, Γ) .*

Note that according to the sufficient conditions in the above theorem regulation is possible for arbitrary compact sets \mathcal{W}_0 if $\Gamma = 0$. The following lemma specifies when this can happen.

Lemma 4.6: *Consider Condition 2(b) of Theorem 4.3. $\Gamma = 0$ if there exists a matrix Π which solves the matrix equations (3.6).*

We now illustrate the linear error feedback design by an example.

Example 4.7: Consider the following system:

$$\begin{cases} x^+ = \begin{bmatrix} 0 & -1 & -1 & 0 \\ 1 & 0 & 0 & 1 \\ 0 & 0 & 0 & -1 \\ 0 & 0 & 1 & 0 \end{bmatrix} x + \begin{bmatrix} 1 & 0 \\ 0 & 1 \\ 1 & 0 \\ 0 & 1 \end{bmatrix} \sigma(u) + \begin{bmatrix} 0 & 2 \\ -2 & -2 \\ -1 & 2 \\ -2 & -1 \end{bmatrix} w \\ w^+ = \begin{bmatrix} 0 & 1 \\ -1 & 0 \end{bmatrix} w \\ e = \begin{bmatrix} 1 & 0 & 0 & 0 \\ 0 & 1 & 0 & 0 \end{bmatrix} x + \begin{bmatrix} -1 & 0 \\ 0 & -1 \end{bmatrix} w \end{cases} \quad (4.13)$$

with $w(0) \in \mathcal{W}_0$ where $\mathcal{W}_0 = \{w \in \mathbb{R}^2 : \|w\| < 0.5\}$. It is straightforward to show that, the solvability conditions for the semi-global linear state feedback output regulation problem are satisfied. More specifically, the matrices,

$$\Pi = \begin{bmatrix} 1 & 0 \\ 0 & 1 \\ 1 & 0 \\ 0 & 1 \end{bmatrix}, \quad \Gamma = \begin{bmatrix} 1 & 0 \\ 0 & 1 \end{bmatrix} \quad (4.14)$$

solve the linear matrix equations (2). Also, $\delta = 0.5$, since $\|\Gamma w\|_\infty \leq 0.5$ for all $w(0) \in \mathcal{W}_0$. Let the set \mathcal{X}_0 be given by $\mathcal{X}_0 = \{x \in \mathbb{R}^4 : \|x\| \leq 2\}$.

Then, following the proof of Theorem 4.3, a choice of ε^* is 4.6×10^{-3} . For $\varepsilon = \varepsilon^*$, the feedback law (4.4) is given by

$$u = - \begin{bmatrix} 0.0529 & -0.0335 & -0.0563 & -0.0340 \\ 0.0335 & -0.0529 & 0.0340 & 0.0563 \end{bmatrix} x + \begin{bmatrix} 0.9966 & -0.0675 \\ 0.0675 & 1.0034 \end{bmatrix} w.$$

For the initial conditions $x(0) = (1, 1, 1, 1)'$, $w(0) = (0.25, -0.25)'$, Figure 4.1 shows the control action and the closed-loop performance of the regulator.

4.2. Linear Observer Based Error Feedback

The semi-global linear observer based error feedback regulator problem can be formulated as follows.

Problem 4.8: Consider the system (3.1) and a compact set $\mathcal{W}_0 \subset \mathbb{R}^s$. The semi-global linear observer based error feedback regulator problem is defined as follows.

For any a priori given (arbitrarily large) bounded sets $\mathcal{X}_0 \subset \mathbb{R}^n$ and $\mathcal{Z}_0 \subset \mathbb{R}^{n+s}$, find, if possible, an error feedback law of the form

$$\begin{cases} \begin{bmatrix} \hat{x}^+ \\ \hat{w}^+ \end{bmatrix} = \begin{bmatrix} A & P \\ 0 & S \end{bmatrix} \begin{bmatrix} \hat{x} \\ \hat{w} \end{bmatrix} + \begin{bmatrix} B \\ 0 \end{bmatrix} \sigma(u) + \begin{bmatrix} L_A \\ L_S \end{bmatrix} (e - [C \quad Q] \begin{bmatrix} \hat{x} \\ \hat{w} \end{bmatrix}) \\ u = F\hat{x} + G\hat{w} \end{cases} \quad (4.15)$$

such that

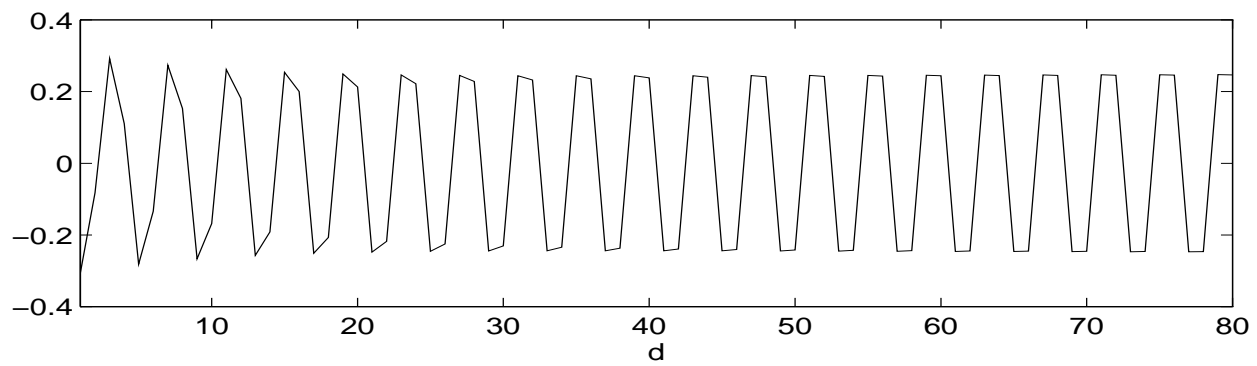
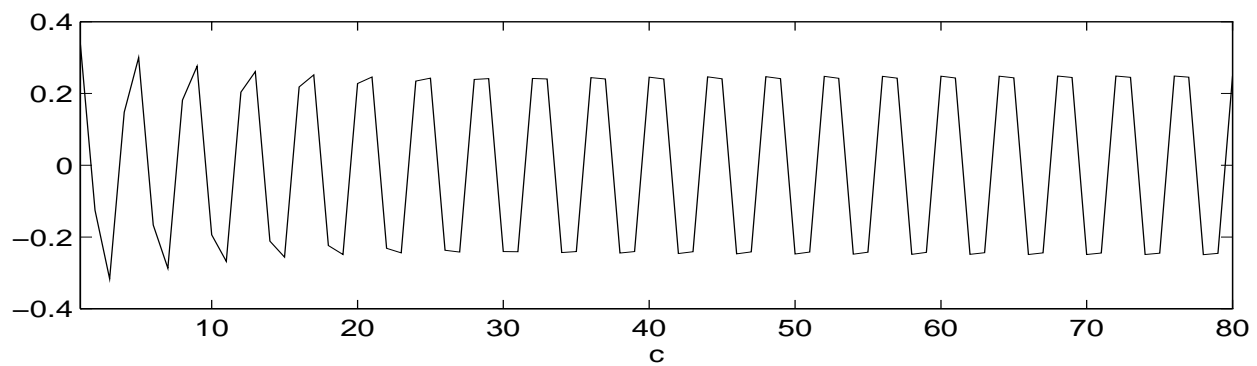
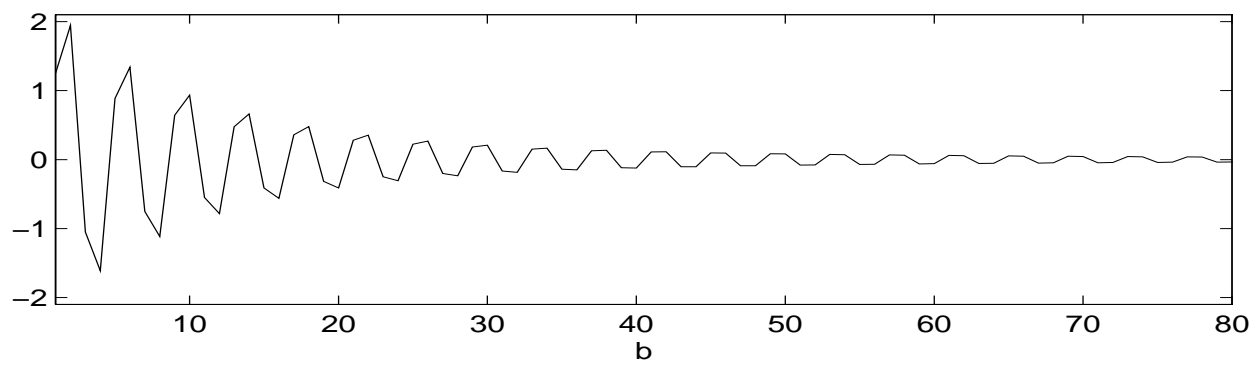
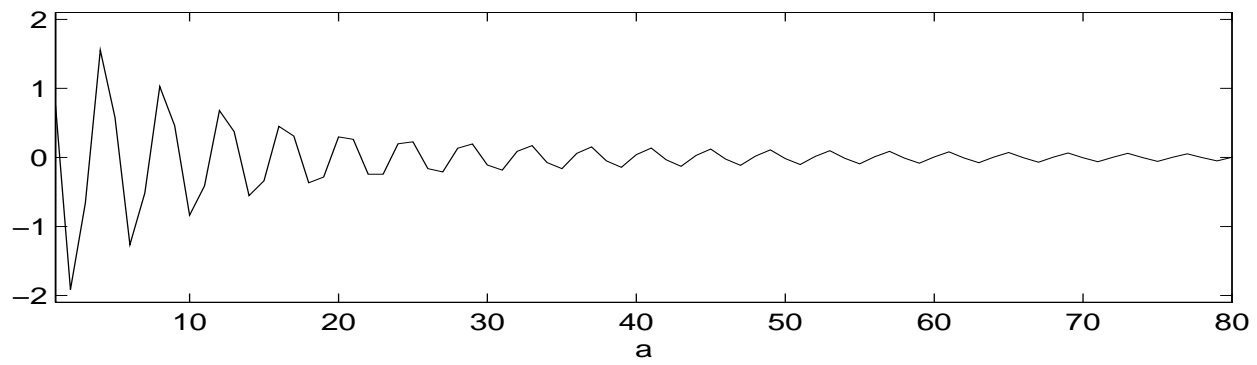

Figure 4.1: $\varepsilon = 4.6 \times 10^{-3}$. a) e_1 ; b) e_2 ; c) u_1 ; d) u_2 .

1. The equilibrium $(x, \hat{x}, \hat{w}) = (0, 0, 0)$ of

$$\begin{cases} x^+ &= Ax + B\sigma(F\hat{x} + G\hat{w}) \\ \begin{bmatrix} \hat{x}^+ \\ \hat{w}^+ \end{bmatrix} &= \begin{bmatrix} A & P \\ 0 & S \end{bmatrix} \begin{bmatrix} \hat{x} \\ \hat{w} \end{bmatrix} + \begin{bmatrix} B \\ 0 \end{bmatrix} \sigma(F\hat{x} + G\hat{w}) + \begin{bmatrix} L_A \\ L_S \end{bmatrix} [C \quad Q] \begin{bmatrix} x - \hat{x} \\ -\hat{w} \end{bmatrix} \end{cases} \quad (4.16)$$

is asymptotically stable with $\mathcal{X}_0 \times \mathcal{Z}_0$ contained in its basin of attraction.

2. For all $(x(0), p(0)) \in \mathcal{X}_0 \times \mathcal{Z}_0$ and $w(0) \in \mathcal{W}_0$, the solution of the closed-loop system satisfies

$$\lim_{k \rightarrow \infty} e(k) = 0. \quad (4.17)$$

Remark 4.9: We would like to emphasize that our definition of the semi-global linear observer based error feedback regulator problem does not view the set of initial conditions of the plant and the initial conditions of the controller dynamics as given data. The set of given data consists of the models of the plant and the exosystem and the set of initial conditions for the exosystem. Therefore, the solvability conditions must be independent of the set of initial conditions of the plant, \mathcal{X}_0 , and the set of initial conditions for the controller dynamics, \mathcal{Z}_0 .

The solvability conditions for semi-global linear observer based error feedback regulator problem are given in the following theorem.

Theorem 4.10: Consider the system (3.1) and the given compact set $\mathcal{W}_0 \subset \mathbb{R}^s$. The semi-global linear observer based error feedback regulator problem is solvable if

1. (A, B) is stabilizable and A has all eigenvalues inside or on the unit circle; Moreover, the pair

$$\left([C \quad Q], \begin{bmatrix} A & P \\ 0 & S \end{bmatrix} \right)$$

is detectable;

2. There exist matrices Π and Γ such that:

(a) They solve the following linear matrix equations :

$$\begin{cases} \Pi S = A\Pi + B\Gamma + P \\ C\Pi + Q = 0 \end{cases} \quad (4.18)$$

(b) There exists a $\delta > 0$ and a $K \geq 0$ such that $\|\Gamma w\|_{\infty, K} \leq 1 - \delta$ for all w with $w(0) \in \mathcal{W}_0$.

Proof : We prove this theorem by first explicitly constructing a family of linear observer based error feedback laws of the form (4.15), parameterized in ε , and then showing that for each pair of sets $\mathcal{X}_0 \subset \mathbb{R}^n$ and $\mathcal{Z}_0 \subset \mathbb{R}^{n+s}$, there exists an $\varepsilon^* > 0$ such that for all $\varepsilon \in (0, \varepsilon^*]$,

both items 1 and 2 in Problem 4.8 are indeed satisfied. The family of linear observer based error feedback laws we construct take the following form

$$\begin{cases} \hat{x}^+ &= A\hat{x} + B\sigma(u) + P\hat{w} + L_A e - L_A(C\hat{x} + Q\hat{w}) \\ \hat{w}^+ &= S\hat{w} + L_S e - L_S(C\hat{x} + Q\hat{w}) \\ u &= -F(\varepsilon)\hat{x} + (F(\varepsilon)\Pi + \Gamma)\hat{w} \end{cases} \quad (4.19)$$

where $F(\varepsilon) := (B'X(\varepsilon)B + I)^{-1}B'X(\varepsilon)A$ with $X(\varepsilon)$ being the solution of the ARE (2.11). It follows from Lemma 2.6 that $A - BF(\varepsilon)$ is Schur stable for all $\varepsilon > 0$. The matrices L_A and L_S are chosen such that the following matrix is Schur stable,

$$\bar{A} := \begin{bmatrix} A - L_A C & P - L_A Q \\ -L_S C & S - L_S Q \end{bmatrix} \quad (4.20)$$

With this family of feedback laws, the closed-loop system consisting of the system (3.1) and the dynamic error feedback laws (4.19) can be written as (we do not write the equation $w^+ = Sw$ explicitly but it is of course always there):

$$\begin{cases} x^+ &= Ax + B\sigma(\Gamma\hat{w} - F(\varepsilon)(\hat{x} - \Pi\hat{w})) + Pw \\ \hat{x}^+ &= A\hat{x} + B\sigma(\Gamma\hat{w} - F(\varepsilon)(\hat{x} - \Pi\hat{w})) + P\hat{w} + L_A C(x - \hat{x}) + L_A Q(w - \hat{w}) \\ \hat{w}^+ &= S\hat{w} + L_S C(x - \hat{x}) + L_S Q(w - \hat{w}) \end{cases} \quad (4.21)$$

We then adopt the invertible change of state variable,

$$\xi = x - \Pi w, \quad \tilde{x} = x - \hat{x}, \quad \tilde{w} = w - \hat{w} \quad (4.22)$$

and rewrite the closed loop system (4.21) as

$$\begin{cases} \xi^+ &= A\xi + B\sigma(-F(\varepsilon)\xi + \Gamma w - \Gamma\tilde{w} + F(\varepsilon)\tilde{\xi}) + (A\Pi - \Pi S + P)w \\ \tilde{x}^+ &= (A - L_A C)\tilde{x} + (P - L_A Q)\tilde{w} \\ \tilde{w}^+ &= -L_S C\tilde{x} + (S - L_S Q)\tilde{w} \end{cases} \quad (4.23)$$

where we have denoted $\tilde{\xi} = \tilde{x} - \Pi\tilde{w}$.

To show that item 1 of Problem 4.8 holds, we note that (4.16) is the same as (4.21) for $w = 0$.

We know (4.21) is equivalent to (4.23) which for $w = 0$ reduces to

$$\begin{cases} \xi^+ &= A\xi + B\sigma(-F(\varepsilon)\xi - \Gamma\tilde{w} + F(\varepsilon)\tilde{\xi}) \\ \tilde{x}^+ &= (A - L_A C)\tilde{x} + (P - L_A Q)\tilde{w} \\ \tilde{w}^+ &= -L_S C\tilde{x} + (S - L_S Q)\tilde{w} \end{cases} \quad (4.24)$$

Denoting $\tilde{m} = [\tilde{x}', \tilde{w}']'$, we write (4.24) in the following compact form,

$$\begin{cases} \xi^+ &= A\xi + B[\sigma(-F(\varepsilon)\xi + M\tilde{m})] \\ \tilde{m}^+ &= \bar{A}\tilde{m} \end{cases} \quad (4.25)$$

and (4.23) in the following form,

$$\begin{cases} \xi^+ &= A\xi + B[\sigma(-F(\varepsilon)\xi + M\tilde{m} + \Gamma w) - \Gamma w] \\ \tilde{m}^+ &= \bar{A}\tilde{m} \end{cases} \quad (4.26)$$

where

$$M = \begin{bmatrix} F(\varepsilon) & 0 \\ 0 & -(\Gamma + F(\varepsilon)\Pi) \end{bmatrix}$$

Recalling that the matrix \bar{A} , defined in (4.20), is Schur stable it readily follows from the second equation of (4.25) that there exists a $K_1 \geq 0$ such that, for all possible initial conditions $(\tilde{x}(0), \tilde{w}(0))$,

$$\|M\tilde{m}\|_{\infty, K_1} \leq \frac{1}{2}, \forall \varepsilon \in (0, 1] \quad (4.27)$$

For any $x(0) \in \mathcal{X}_0$, $\xi(K_1)$ belongs to a bounded set, say \mathcal{U}_{K_1} , independent of ε since \mathcal{X}_0 is bounded and $\xi(K_1)$ is determined by a linear difference equation (4.25) with bounded input $\sigma(\cdot)$. Let $\varepsilon_1^* \in (0, 1]$ be chosen such that for all $\varepsilon \in (0, \varepsilon_1^*]$, $\|F(\varepsilon)\| < 1/2$, and $\|F(\varepsilon)\Pi\| < 1/2$. This ensures that $\|M\|^2 < (1 + \|\Gamma\|)^2$. Let's define $\beta := (1 + \|\Gamma\|)^2(1 + \|B\|^2)$ for later use. Let \tilde{X} be the unique positive definite solution to the Lyapunov equation

$$\tilde{X} = \bar{A}'\tilde{X}\bar{A} + I. \quad (4.28)$$

Such a \tilde{X} exists since \bar{A} is Schur stable.

We next define a Lyapunov function

$$V(\xi, \tilde{m}) = \xi'X(\varepsilon)\xi + (\beta + 1)\tilde{m}'\tilde{X}\tilde{m}. \quad (4.29)$$

and let $c_1 > 0$ be such that

$$c_1 \geq \sup_{\xi \in \mathcal{U}_{K_1}, \varepsilon \in (0, 1]} V(\xi, \tilde{m}). \quad (4.30)$$

Such a c_1 exists since $\lim_{\varepsilon \rightarrow 0} X(\varepsilon) = 0$ by (2.12) and \mathcal{U}_{K_1} is bounded. Let $\varepsilon_2^* \in (0, \varepsilon_1^*]$ be such that $\xi \in L_V(c_1)$ implies that $|F(\varepsilon)\xi|_\infty \leq \frac{1}{2}$. The existence of such an ε_2^* is due to Lemma 2.7 and the fact that $\lim_{\varepsilon \rightarrow 0} X(\varepsilon) = 0$. Hence for $k \geq K_1$, (4.25) takes the form

$$\begin{cases} \xi^+ &= (A - BF(\varepsilon))\xi + BM\tilde{m} \\ \tilde{m}^+ &= \bar{A}\tilde{m} \end{cases} \quad (4.31)$$

Now, the evaluation of the deference of V , $k \geq K_1$, inside the set $L_V(c_1)$, using (2.11), shows that for all $\xi \in L_V(c_1)$,

$$\begin{aligned} & V(\xi^+, \tilde{m}^+) - V(\xi, \tilde{m}) \\ &= [(A - BF(\varepsilon))\xi + BM\tilde{m}]'X(\varepsilon)[(A - BF(\varepsilon))\xi + BM\tilde{m}] - \xi'X(\varepsilon)\xi - (\beta + 1)\tilde{m}'\tilde{m} \\ &= -\varepsilon\xi'\xi - \xi'F'(\varepsilon)F(\varepsilon)\xi + 2\tilde{m}'M'F(\varepsilon)\xi + \tilde{m}'M'B'BM\tilde{m} - (\beta + 1)\tilde{m}'\tilde{m} \\ &\leq -\varepsilon\|\xi\|^2 - \|F(\varepsilon)\xi\|^2 + \|F(\varepsilon)\xi\|^2 + \|M\|^2\|\tilde{m}\|^2 + \|B\|^2\|M\|^2\|\tilde{m}\|^2 - (\beta + 1)\|\tilde{m}\|^2 \\ &\leq -\varepsilon\|\xi\|^2 - \|\tilde{m}\|^2 \end{aligned}$$

Hence we conclude that, for any a priori given set \mathcal{X}_0 and \mathcal{Z}_0 , there exists an $\varepsilon_2^* \in (0, \varepsilon_1^*]$ such that for each $\varepsilon \in (0, \varepsilon_2^*]$, the equilibrium $(0,0,0)$ of (4.16) is asymptotically stable with $\mathcal{X}_0 \times \mathcal{Z}_0$ contained in its basin of attraction.

We now proceed to show that item 2 of Problem 4.8 also holds. To this end, we consider the closed-loop system (4.23). Recalling that the matrix \bar{A} is Schur stable, and using (4.23),

which is equivalent to the system (4.26) it readily follows from the last two equations of (4.23) that there exists a $K_2 \geq K$ such that, for all possible initial conditions $(\tilde{x}(0), \tilde{w}(0))$,

$$\|M\tilde{m}\|_{\infty, K_2} \leq \frac{\delta}{2}, \quad \forall \varepsilon \in (0, 1] \quad (4.32)$$

We then consider the first equation of (4.26). By Condition 2(b), $\|\Gamma w\|_{\infty, K} < 1 - \delta$. Moreover, for any $x(0) \in \mathcal{X}_0$ and any $w(0) \in \mathcal{W}_0$, $\xi(K_2)$ belongs to a bounded set, say \mathcal{U}_{K_2} , independent of ε since \mathcal{X}_0 and \mathcal{W}_0 are both bounded and $\xi(K_2)$ is determined by a linear difference equation with bounded inputs $\sigma(u)$ and Γw . Then, using the same Lyapunov function as in (4.29), let $c_2 > 0$ be such that

$$c_2 \geq \sup_{\xi \in \mathcal{U}_{K_2}, \varepsilon \in (0, 1]} V(\xi, \tilde{m}). \quad (4.33)$$

Such a c_2 exists since $\lim_{\varepsilon \rightarrow 0} X(\varepsilon) = 0$ by (2.12) and \mathcal{U}_{K_2} is bounded. Let $\varepsilon_3^* \in (0, 1]$ be such that $\xi \in L_V(c_2)$ implies that $|F(\varepsilon)\xi|_{\infty} \leq \frac{\delta}{2}$. The existence of such an ε_3^* is again due to Lemma 2.7 and the fact that $\lim_{\varepsilon \rightarrow 0} X(\varepsilon) = 0$. Hence the system (4.26) operates in the linear region after time K_2 . Using the same technique as before, it can then be shown that the system (4.16) is asymptotically stable. Hence, $e(k) = C\xi(k) \rightarrow 0$ as $k \rightarrow \infty$.

Finally, taking $\varepsilon^* = \min\{\varepsilon_2^*, \varepsilon_3^*\}$, we complete our proof. \blacksquare

Remark 4.11: *As in the state feedback case, in view of Yang's results ([20]) and the solvability conditions for the error feedback output regulator problem for linear systems in the absence of input saturation as given by Theorem 2.4, it is obvious to observe that Conditions 1 and 2(a) of Theorem 4.10 are necessary. The crucial condition for the solvability of this semi-global linear observer based error feedback regulator problem is Condition 2(b), which is a sufficient condition. In section 5 we will discuss the necessity of Condition 2(b).*

Example 4.12: *We consider the same plant and the exosystem as in Example 4.7. However, this time, the state x and w are not available for feedback, which forces us to use error feedback regulators. Let the sets $\mathcal{W}_0 = \{w \in \mathbb{R}^2 : \|w\| < 0.15\}$ and $\mathcal{X}_0 = \{x \in \mathbb{R}^4 : \|x\| < 0.15\}$. Let the set \mathcal{Z}_0 , be given by $\mathcal{Z}_0 = \{z \in \mathbb{R}^6 : \|z\| \leq 0.2\}$. Following the proof of Theorem 4.10, a suitable choice of ε^* is 1.9325×10^{-3} . It can be verified that the matrix \bar{A} as defined in (4.20) is asymptotically stable, if we choose,*

$$L_A = \begin{bmatrix} -1.2489 \times 10^{-1} & -1.6643 \times 10^{-2} \\ 9.0244 \times 10^{-1} & 8.7426 \times 10^{-1} \\ 7.5000 \times 10^{-1} & 0.0000 \times 10^0 \\ 7.7352 \times 10^{-1} & -6.3254 \times 10^{-4} \end{bmatrix} \quad L_S = \begin{bmatrix} 3.7468 \times 10^{-1} & 4.9928 \times 10^{-2} \\ 3.8676 \times 10^{-1} & 3.7468 \times 10^{-1} \end{bmatrix}$$

For $\varepsilon = \varepsilon^*$, the feedback laws (4.19) are given by

$$\begin{cases} \hat{x}^+ &= A\hat{x} + B\sigma(u) + P\hat{w} + L_A C(x - \hat{x}) + L_A Q(w - \hat{w}) \\ \hat{w}^+ &= S\hat{w} + L_S C(x - \hat{x}) + L_S Q(w - \hat{w}) \\ u &= \begin{bmatrix} 0.0353 & -0.0222 & -0.0368 & -0.0224 \\ 0.0222 & -0.0353 & 0.0224 & 0.0368 \end{bmatrix} \hat{x} + \begin{bmatrix} 0.9986 & -0.0446 \\ 0.0446 & 1.0014 \end{bmatrix} \hat{w} \end{cases} \quad (4.34)$$

For the initial conditions $x(0) = (0.075, 0.075, 0.075, 0.075)'$, $w(0) = (0.1, -0.1)'$, $\hat{x}(0) = (0, 0, 0, 0)'$, $\hat{w}(0) = (0, 0)'$, Figure 4.2 shows the control action and the closed-loop performance for the dynamic error feedback regulator.

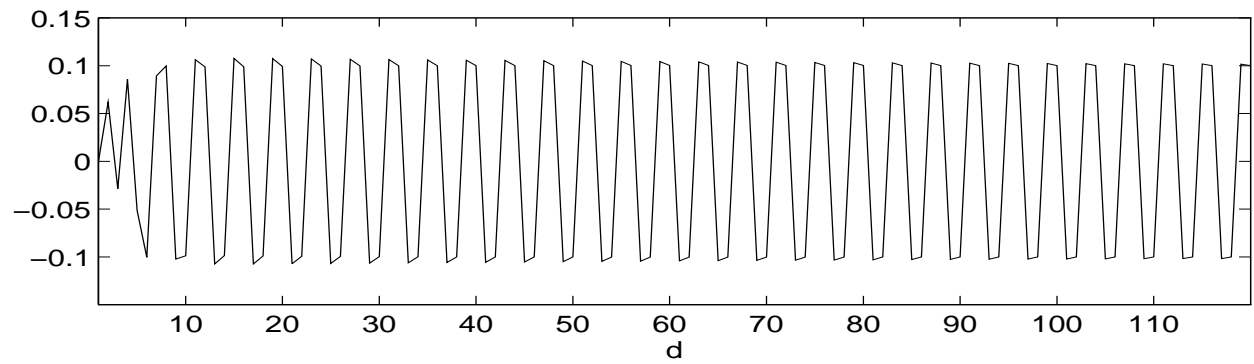
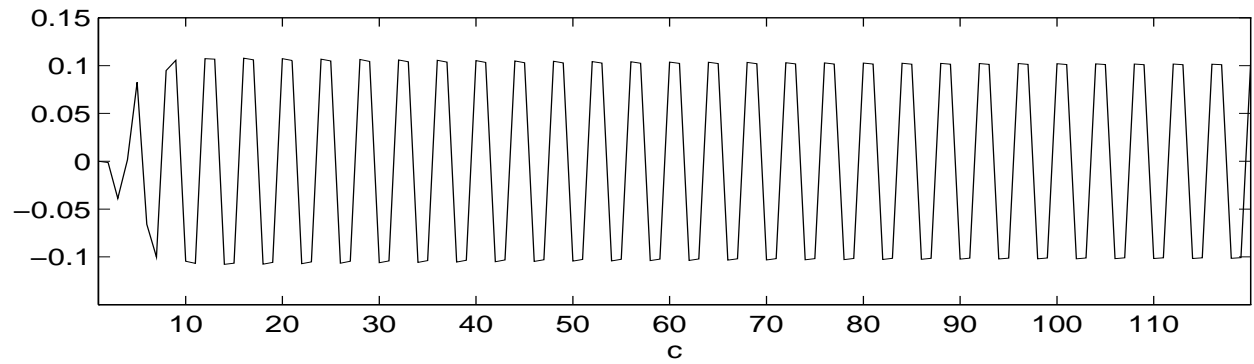
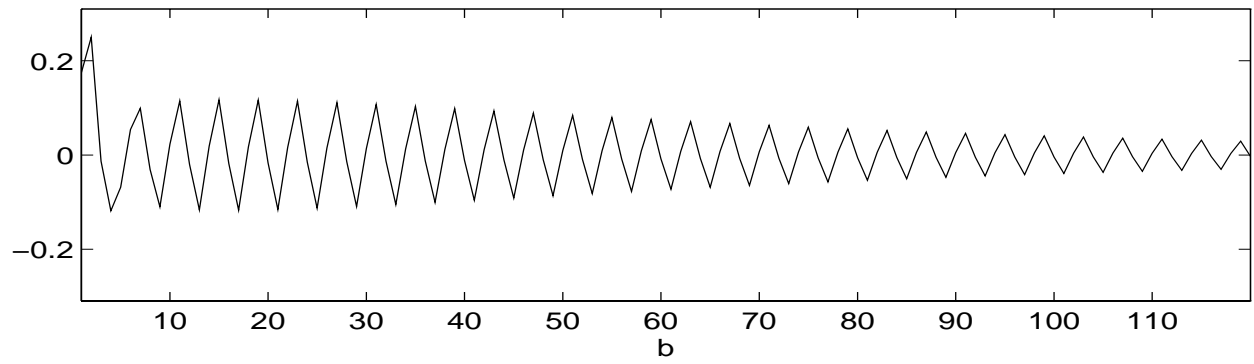
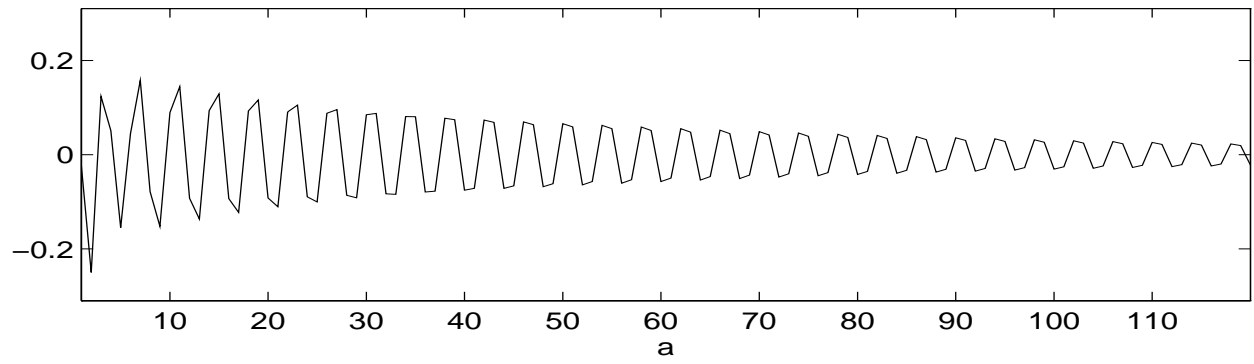

Figure 4.2: $\varepsilon = 1.9325 \times 10^{-3}$. a) e_1 ; b) e_2 ; c) u_1 ; d) u_2 .

5. Necessary Conditions – Linear versus Nonlinear Regulator

The semi-global state feedback regulator problem and semi-global error feedback regulator problems as defined in Section 3, require linear regulators. The sufficient conditions for the existence of such linear regulators were given in Section 3. In this section we examine the necessity of these conditions. The necessity issue must be examined on two fronts.

The first issue is to examine the necessity of the solvability conditions given in Section 3 for the existence of linear regulators. The second issue is to examine whether we can weaken the solvability conditions if we allow non-linear regulators in our definitions of the state and the error feedback regulator problem. It turns out that under certain mild conditions our solvability conditions for the existence of linear regulators are basically necessary. Moreover, these conditions cannot be weakened by allowing nonlinear regulators. We also make an interesting observation that whenever these mild conditions are violated, there *might* be nonlinear state feedbacks that achieve output regulation while no linear state feedbacks would do so.

The necessary condition for the existence of the semi-global state feedback regulator using a general nonlinear feedback law is given in the following theorem.

Theorem 5.1: *Consider the plant and the exosystem (3.1). Let assumptions A1 and A2 hold. Assume that in the absence of input saturation, the linear state feedback regulator problem is solvable, i.e., there exist matrices Π and Γ which solve the linear matrix equations (2.6). Also assume that $(A, B, C, 0)$ is left-invertible and has no invariant zeros on the unit circle. Then, a necessary condition for the existence of a general, possibly nonlinear, state feedback law that achieves semi-global regulation for (3.1) is that, for all $\varepsilon > 0$, there exists a $K \geq 0$ such that*

$$\|\Gamma w(k)\|_{\infty, K} \leq 1 + \varepsilon, \quad \forall w(0) \in \mathcal{W}_0 \quad (5.1)$$

Proof : The proof of the above theorem depends on a result described in the appendix. We will assume in the proof that the reader is familiar with these results. Consider the system (3.1) without the saturation element:

$$\begin{cases} x^+ &= Ax + Bv + Pw \\ w^+ &= Sw \\ e &= Cx + Qw \end{cases} \quad (5.2)$$

Suppose that we have some arbitrary nonlinear feedback $u = \alpha(x, w)$ which achieves regulation for the system (3.1). Then the feedback $v = \sigma(\alpha(x, w))$ will achieve regulation for the system (5.2).

We note that

$$v = -Fx + (\Gamma + F\Pi)w$$

is a linear feedback which achieves regulation for the system (5.2). Moreover,

$$v(k) - \Gamma w(k) \rightarrow 0 \quad \text{as } k \rightarrow \infty \quad (5.3)$$

We have two feedbacks which achieve regulation for the linear system (5.2). One is nonlinear and satisfies a certain amplitude constraint. The other feedback is a linear feedback of which

we have no a priori knowledge regarding its amplitude. Our aim is to show that the linear feedback must necessarily satisfy an amplitude constraint asymptotically as $k \rightarrow \infty$. We define the difference between the two control inputs:

$$s(k) = [-Fx + (\Gamma + F\Pi)w](k) - [\sigma(\alpha(x, w))](k)$$

If we apply s to the system:

$$\begin{cases} x^+ &= Ax + Bs \\ e &= Cx \end{cases} \quad (5.4)$$

with zero initial conditions then we have $e(k) \rightarrow 0$ (since both the linear feedback and the nonlinear saturating feedback achieve regulation). By applying Theorem A.1 we find that $s(k) \rightarrow 0$ as $k \rightarrow \infty$.

If we look at our definition for s , we see that the first component asymptotically converges to Γw . The second term is bounded by 1. Therefore it is easy to see that if s converges to 0 we must necessarily have $\limsup_{k \rightarrow \infty} |\Gamma w(k)|_\infty \leq 1$. ■

Remark 5.2: *The necessary conditions given in Theorem 5.1 are slightly different from the sufficient solvability conditions given in Theorem 4.3. It is necessary that $|\Gamma w(k)|_\infty$ is asymptotically less than or equal to 1 while in our sufficient conditions we require that $|\Gamma w(k)|_\infty$ is asymptotically strictly less than 1. Hence, one can conclude that under Assumption A1 and the condition that $(A, B, C, 0)$ is left invertible and has no invariant zeros on the unit circle, a nonlinear feedback regulator cannot do strictly better than a linear feedback regulator.*

An interesting question is whether one can weaken the necessary condition given in Theorem 5.1, if $(A, B, C, 0)$ is not left invertible and/or has invariant zeros in the unit circle. The following example shows that, in fact, this is the case. More significantly, this example shows that if $(A, B, C, 0)$ is not left invertible, nonlinear feedbacks might achieve semi-global regulation while no linear feedback can do so.

Example 5.3: *Consider the following system:*

$$\begin{cases} x^+ = \begin{bmatrix} 0.5 & 0 & 0 & 0 \\ 0 & 0.5 & 0 & 0 \\ 0 & 0 & 0.5 & 0 \\ 0 & 0 & 0 & 0.5 \end{bmatrix} x + \begin{bmatrix} 1 & 0 & 0 & 0 \\ 0 & 1 & 0 & 0 \\ 0 & 0 & 1 & 0 \\ 0 & 0 & 0 & 1 \end{bmatrix} \sigma(u) \\ w^+ = \begin{bmatrix} 0 & 0 & 0 \\ 0 & 0 & 0 \\ 0 & 0 & 0 \end{bmatrix} w \\ e = \begin{bmatrix} 1 & -1 & 0 & 0 \\ 1 & 0 & -1 & 0 \\ 1 & 0 & 0 & -1 \end{bmatrix} x - \frac{2}{7} \begin{bmatrix} 3 & 3 & 6 \\ 6 & 6 & 0 \\ 0 & 6 & 6 \end{bmatrix} w \end{cases} \quad (5.5)$$

with $w(0) \in \mathcal{W}_0$ where

$$\mathcal{W}_0 = \{ w \in \mathbb{R}^3 \mid |w|_\infty < 1 \}$$

It is straightforward to show that in the absence of input saturation the linear state feedback regulator is solvable. In fact, the matrices Π and Γ that solve the linear matrix equations (2.6) are given by,

$$\Gamma = \frac{1}{7} \begin{bmatrix} f_1 & f_2 + 6 & f_3 \\ f_1 - 3 & f_2 + 3 & f_3 - 6 \\ f_1 - 6 & f_2 & f_3 \\ f_1 & f_2 & f_3 - 6 \end{bmatrix}, \Pi = 2\Gamma$$

where f_1, f_2 and f_3 are any real numbers.

In the presence of input saturation, however, the sufficient conditions of Theorem 4.3 are not satisfied. More specifically, Condition 2(b) of Theorem 4.3 cannot be satisfied for any choice of f_1, f_2 and f_3 . Hence, the design procedure developed in Section 4 cannot be applied to this example. It is also evident that the necessary condition (5.1) is not satisfied either. But, since $(A, B, C, 0)$ in the given plant is not left invertible, Theorem 5.1 does not apply anyway. In what follows, we will establish the following two facts for the plant and the exosystem (5.5),

1. There exist nonlinear feedbacks that achieve semi-global output regulation. This implies that the necessary condition (5.1) given in Theorem 5.1 are not valid if $(A, B, C, 0)$ is not left invertible;
2. There exist no linear state feedbacks that can achieve semi-global output regulation. This establishes an important result. That is, if $(A, B, C, 0)$ is not left invertible, the semi-global output regulation might be achieved via nonlinear feedbacks while no linear feedbacks can do so.

As the plant is already asymptotically stable, let us consider a nonlinear feedback of only the exosystem state of the form,

$$u = \begin{bmatrix} 1 \\ 1 \\ 1 \\ 1 \end{bmatrix} f(w) + \begin{bmatrix} 0 & 3 & 0 \\ -1.5 & 1.5 & -3 \\ -3 & 0 & 0 \\ 0 & 0 & -3 \end{bmatrix} w. \quad (5.6)$$

and

$$f(w) = \frac{6}{7}(1 - \lambda_1 - \lambda_2 - \lambda_3)$$

where $\lambda_1, \lambda_2, \lambda_3$ are such that $|\lambda_1| + |\lambda_2| + |\lambda_3| \leq 1$ and:

$$w = \lambda_1 \begin{bmatrix} 1 \\ 1 \\ 1 \end{bmatrix} + \lambda_2 \begin{bmatrix} 1 \\ 1 \\ -1 \end{bmatrix} + \lambda_3 \begin{bmatrix} -1 \\ 1 \\ 1 \end{bmatrix} + (1 - \lambda_1 - \lambda_2 - \lambda_3) \begin{bmatrix} 1 \\ -1 \\ 1 \end{bmatrix} \quad (5.7)$$

In this way the λ_i are not uniquely determined and we make the special choice of choosing those λ_i satisfying (5.7) with minimal λ_1 . In this way our feedback is nonlinear but continuous. Note that for any $w(0) \in \mathcal{W}_0$, $w \equiv w(0)$. It is then not hard to check that the above nonlinear feedback achieves regulation.

We still want to show that there does not exist a linear feedback achieving regulation. Assume the linear feedback $u = Fw$ achieves regulation. Define

$$v = \begin{bmatrix} 1 & -1 & 0 & 0 \\ 1 & 0 & -1 & 0 \\ 1 & 0 & 0 & -1 \end{bmatrix} \sigma(Fw). \quad (5.8)$$

It is easy to see that this feedback achieves regulation for the following system:

$$\left\{ \begin{array}{l} x^+ = \begin{bmatrix} 0.5 & 0 & 0 & 0 \\ 0 & 0.5 & 0 & 0 \\ 0 & 0 & 0.5 & 0 \\ 0 & 0 & 0 & 0.5 \end{bmatrix} x + \begin{bmatrix} 0 & 0 & 0 \\ -1 & 0 & 0 \\ 0 & -1 & 0 \\ 0 & 0 & -1 \end{bmatrix} v \\ w^+ = \begin{bmatrix} 0 & 0 & 0 \\ 0 & 0 & 0 \\ 0 & 0 & 0 \end{bmatrix} w \\ e = \begin{bmatrix} 1 & -1 & 0 & 0 \\ 1 & 0 & -1 & 0 \\ 1 & 0 & 0 & -1 \end{bmatrix} x - \frac{2}{7} \begin{bmatrix} 3 & 3 & 6 \\ 6 & 6 & 0 \\ 0 & 6 & 6 \end{bmatrix} w \end{array} \right. \quad (5.9)$$

with $w(0) \in \mathcal{W}_0$. However also the following linear feedback achieves regulation for this system:

$$v = \frac{2}{7} \begin{bmatrix} 3 & 3 & 6 \\ 6 & 6 & 0 \\ 0 & 6 & 6 \end{bmatrix} w. \quad (5.10)$$

Since the system from v to e is left-invertible, we know from Theorem A.1 that the asymptotic behavior of signals achieving regulation is unique. We have two feedbacks (5.8) and (5.10) achieving regulation so asymptotically we must have:

$$\begin{bmatrix} 1 & -1 & 0 & 0 \\ 1 & 0 & -1 & 0 \\ 1 & 0 & 0 & -1 \end{bmatrix} \sigma(Fw) = \frac{2}{7} \begin{bmatrix} 3 & 3 & 6 \\ 6 & 6 & 0 \\ 0 & 6 & 6 \end{bmatrix} w$$

Using that w is not depending on time and a simple transformation, we note that the existence of a linear feedback achieving regulation requires the existence of a linear feedback F satisfying:

$$\left| \begin{bmatrix} 2 \\ 2 \\ 2 \\ 2 \end{bmatrix} Fw + \begin{bmatrix} 0 & 6 & 0 \\ -3 & 3 & -6 \\ -6 & 0 & 0 \\ 0 & 0 & -6 \end{bmatrix} w \right| \leq 7$$

However, it was shown in [13] for this particular example that this is not possible.

Hence we can note in conclusion that for this example there does exist a suitable nonlinear feedback but no suitable linear feedback.

Remark 5.4: We can pose similar questions regarding the semi-global error feedback regulator problem. Again, there is the question whether the conditions of Theorem 4.10 are actually necessary for the solvability of the semi-global error feedback regulator problem. But Theorem 5.1 basically resolves this question since the conditions which are necessary for the state feedback case are clearly also necessary for the case of error feedback on the basis of the error signal only. The only additional assumption we made in Theorem 4.10 is the detectability assumption which is clearly necessary for the stabilization of our system.

6. Generalized Semi-Global Linear Feedback Regulator Problems

We have formulated the semi-global linear feedback regulator problems for linear systems subject to input saturation following the traditional formulation of linear regulator problems where the exosystem is autonomous. As a result, the disturbances and the references generated by the exosystem contain only the frequency components of the exosystem. In an effort to broaden the class of disturbance and reference signals, we formulate in this section the generalized semi-global linear feedback regulator problem, for which an external driving signal to the exosystem is included. More specifically, we consider a multivariable system with inputs that are subject to saturation together with an exosystem that generates disturbance and reference signals as described by the following system

$$\begin{cases} x^+ &= Ax + B\sigma(u) + Pw \\ w^+ &= Sw + r \\ e &= Cx + Qw \end{cases} \quad (6.1)$$

where $x \in \mathbb{R}^n$, $w \in \mathbb{R}^s$, $u \in \mathbb{R}^m$, $e \in \mathbb{R}^p$, $r \in L_\infty$ is an external signal to the exosystem, and σ is a vector-valued saturation function as defined by (3.2).

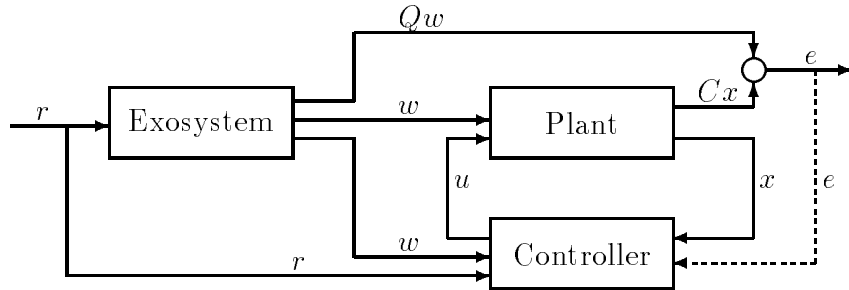

Figure 6.1: Configuration of a generalized regulator

The generalized semi-global linear state feedback regulator problem and the generalized linear observer based error feedback regulator problem are formulated as follows.

Problem 6.1: Consider the system (6.1), a compact set $\mathcal{W}_0 \subset \mathbb{R}^s$ and a compact set $\mathcal{R} \subset L_\infty$. The generalized semi-global linear state feedback regulator problem is defined as follows.

For any a priori given (arbitrarily large) bounded set $\mathcal{X}_0 \subset \mathbb{R}^n$, find, if possible, a linear static feedback law $u = Fx + Gw + Hr$, such that

1. The equilibrium $x = 0$ of

$$x^+ = Ax + B\sigma(Fx) \quad (6.2)$$

is locally asymptotically stable with \mathcal{X}_0 contained in its basin of attraction;

2. For all $x(0) \in \mathcal{X}_0$, $w(0) \in \mathcal{W}_0$ and $r \in \mathcal{R}$, the solution of the closed-loop system satisfies

$$\lim_{k \rightarrow \infty} e(k) = 0. \quad (6.3)$$

Problem 6.2: Consider the system (6.1) and two compact sets $\mathcal{W}_0 \subset \mathbb{R}^s$ and $\mathcal{R} \subset L_\infty$. The generalized semi-global linear observer based error feedback regulator problem is defined as follows.

For any a priori given (arbitrarily large) bounded sets $\mathcal{X}_0 \subset \mathbb{R}^n$ and $\mathcal{Z}_0 \subset \mathbb{R}^{n+s}$, find, if possible, a linear observer based error feedback law of the form:

$$\begin{cases} \begin{bmatrix} \hat{x}^+ \\ \hat{w}^+ \end{bmatrix} = \begin{bmatrix} A & P \\ 0 & S \end{bmatrix} \begin{bmatrix} \hat{x} \\ \hat{w} \end{bmatrix} + \begin{bmatrix} B \\ 0 \end{bmatrix} \sigma_h(u) + \begin{bmatrix} L_A \\ L_S \end{bmatrix} (e - [C \quad Q] \begin{bmatrix} \hat{x} \\ \hat{w} \end{bmatrix}) \\ u = F\hat{x} + G\hat{w} + Hr \end{cases} \quad (6.4)$$

such that

1. The equilibrium $(x, \hat{x}, \hat{w}) = (0, 0, 0)$ of

$$\begin{cases} x^+ = Ax + B\sigma_h(F\hat{x} + G\hat{w}) \\ \begin{bmatrix} \hat{x}^+ \\ \hat{w}^+ \end{bmatrix} = \begin{bmatrix} A & P \\ 0 & S \end{bmatrix} \begin{bmatrix} \hat{x} \\ \hat{w} \end{bmatrix} + \begin{bmatrix} B \\ 0 \end{bmatrix} \sigma_h(F\hat{x} + G\hat{w}) + \begin{bmatrix} L_A \\ L_S \end{bmatrix} [C \quad Q] \begin{bmatrix} x - \hat{x} \\ -\hat{w} \end{bmatrix} \end{cases} \quad (6.5)$$

is locally asymptotically stable with $\mathcal{X}_0 \times \mathcal{Z}_0$ contained in its basin of attraction;

2. For all $(x(0), \hat{x}(0), \hat{w}(0)) \in \mathcal{X}_0 \times \mathcal{Z}_0$, $w(0) \in \mathcal{W}_0$, and all $r \in \mathcal{R}$, the solution of the closed-loop system satisfies

$$\lim_{k \rightarrow \infty} e(k) = 0. \quad (6.6)$$

Remark 6.3: We would like to emphasize here that our definition of the generalized semi-global linear state feedback [respectively, linear observer based error feedback] regulator problem does not view the set of initial conditions of the plant as given data. The set of given data consists of the models of the plant and the exosystem, the set of initial conditions for the exosystem and the set of external input to the exosystem. Moreover, the generalized semi-global linear state feedback [respectively, error feedback] regulator problem reduces to the semi-global linear state feedback [respectively, error feedback] regulator problem as formulated in Problem 4.1 [respectively, Problem 4.8] when the external input r to the exosystem is nonexistent.

Remark 6.4: We would also like to emphasize that unlike the traditional regulator problem where all interesting cases arise when the poles of the exosystem are inside or on the unit circle, for the generalized regulator problem, there are interesting cases even when the exosystem is asymptotically stable.

We will give solvability conditions for the above two problems. For clarity, we present these solvability conditions in two separate subsections, one for each of the two problems.

6.1. Linear Static State Feedback

The solvability conditions for generalized semi-global linear state feedback regulator problem is given in the following theorem.

Theorem 6.5: *Consider the system (6.1) and given compact sets $\mathcal{W}_0 \subset \mathbb{R}^s$ and $\mathcal{R} \subset L_\infty$. The generalized semi-global linear state feedback regulator problem is solvable if*

1. (A, B) is stabilizable and A has all its eigenvalues on or inside the unit circle.
2. There exist matrices Π and Γ such that:
 - (a) They solve the following linear matrix equations :

$$\begin{cases} \Pi S = A\Pi + B\Gamma + P \\ C\Pi + Q = 0 \end{cases} \quad (6.7)$$

- (b) For each $r \in \mathcal{R}$, there exists a function $\tilde{r} \in L_\infty$ such that $\Pi r = B\tilde{r}$.
 - (c) There exists a $\delta > 0$ and a $K \geq 0$ such that $\|\Gamma w + \tilde{r}\|_{\infty, K} \leq 1 - \delta$ for all w with $w(0) \in \mathcal{W}_0$ and all $r \in \mathcal{R}$.

Remark 6.6: *We would like to make the following observations on the solvability conditions as given in the above theorem:*

1. As expected, the solvability conditions for the generalized semi-global linear state feedback regulator problem as given in the above theorem reduce to those for the semi-global linear state feedback regulator problem as formulated in Problem 4.1 when the external input to the exosystem is nonexistent.
2. If $\text{Im}\Pi \subset \text{Im}B$, then Condition 2 (b) is automatically satisfied any given set \mathcal{R} .
3. If $\text{Im}\Pi \cap \text{Im}B = \{0\}$, then Condition 2 (b) can never be satisfied for any given \mathcal{R} except for $\mathcal{R} = \{0\}$.

Proof of Theorem 6.5: The proof of this theorem is similar, *mutatis mutandis*, to that of Theorem 4.3. As in the proof of Theorem 4.3, we prove this theorem by first constructing a family of linear static state feedback laws, parameterized in ε , and then showing that for each given set \mathcal{X}_0 , there exists an $\varepsilon^* > 0$ such that for all $\varepsilon \in (0, \varepsilon^*]$, both items 1 and 2 of Problem 6.1 hold. The family of linear static state feedback laws we construct takes the following form

$$u = -F(\varepsilon)x + (F(\varepsilon)\Pi + \Gamma)w + \tilde{r} \quad (6.8)$$

where $F(\varepsilon) := (B'X(\varepsilon)B + I)^{-1}B'X(\varepsilon)A$ with $X(\varepsilon)$ being the solution of the ARE (2.11). The rest of the proof is the same as that of Theorem 4.3 except that (4.6) takes the following slightly different form

$$\xi^+ = A\xi + B(\sigma(u) - \Gamma w - \tilde{r}) \quad (6.9)$$

■

6.2. Linear Observer Based Error Feedback

The solvability conditions for generalized semi-global linear observer based error feedback regulator problem is given in the following theorem.

Theorem 6.7: Consider the system (6.1) and the given compact sets $\mathcal{W}_0 \subset \mathbb{R}^s$ and $\mathcal{R} \subset L_\infty$. The semi-global linear observer based error feedback regulator problem is solvable if

1. (A, B) is stabilizable and A has all its eigenvalues inside or on the unit circle. Moreover, the pair

$$\left([C \ Q], \begin{bmatrix} A & P \\ 0 & S \end{bmatrix} \right)$$

is detectable;

2. There exist matrices Π and Γ such that:

- (a) They solve the following linear matrix equations :

$$\begin{cases} \Pi S = A\Pi + B\Gamma + P \\ C\Pi + Q = 0 \end{cases} \quad (6.10)$$

- (b) For each $r \in \mathcal{R}$, there exists a function $\tilde{r} \in L_\infty$ such that $\Pi r = B\tilde{r}$ for all $k \geq 0$.

- (c) There exist a $\delta > 0$ and a $K \geq 0$ such that $\|\Gamma w + \tilde{r}\|_{\infty, K} \leq 1 - \delta$ for all w with $w(0) \in \mathcal{W}_0$ and all $r \in \mathcal{R}$.

Remark 6.8: As expected, the solvability conditions for the generalized semi-global linear observer based error feedback regulator problem as given in the above theorem reduces to those for the semi-global linear observer based error feedback regulator problem as formulated in Problem 4.8 when the external input to the exosystem is nonexistent.

Proof of Theorem 6.7 : The proof of this theorem is similar, *mutatis mutandis* to that of Theorem 4.10. As in the proof of Theorem 4.10, we prove this theorem by first constructing a family of linear observer based error feedback laws, parameterized in ε , and then showing that both items 1 and 2 of Problem 6.2 indeed hold. The family of linear observer based error feedback laws we construct takes the following form

$$\begin{cases} \hat{x}^+ &= A\hat{x} + B\sigma(u) + P\hat{w} + L_A e - L_A(C\hat{x} + Q\hat{w}) \\ \hat{w}^+ &= S\hat{w} + L_S e + L_S(C\hat{x} + Q\hat{w}) \\ u &= -F(\varepsilon)\hat{x} + (F(\varepsilon)\Pi + \Gamma)\hat{w} + \tilde{r} \end{cases} \quad (6.11)$$

where $F(\varepsilon) := (B'X(\varepsilon)B + I)^{-1}B'X(\varepsilon)A$ with $X(\varepsilon)$ being the solution of the ARE (2.11), and L_A and L_S are such that the following matrix is Schur stable,

$$\bar{A} := \begin{bmatrix} A - L_A C & P - L_A Q \\ -L_S C & S - L_S Q \end{bmatrix}$$

The rest of the proof is the same as that of Theorem 4.10 except that (4.23) takes the following form instead

$$\begin{cases} \xi^+ &= A\xi + B\sigma(\Gamma(w - \tilde{w}) + F(\varepsilon)(\tilde{x} - \Pi\tilde{w} - \xi) + \tilde{r}) - B\Gamma w - \Pi r \\ \tilde{x}^+ &= (A - L_A C)\tilde{x} + (P - L_A Q)\tilde{w} \\ \tilde{w}^+ &= -L_S C\tilde{x} + (S - L_S Q)\tilde{w} \end{cases}$$

■

7. Conclusions

In this paper we have established results parallel to that of [10]. More specifically, we have studied the output regulation problem for linear discrete-time systems subject to input saturation. We have shown that the semi-global setting is natural for this problem.

Under a mild assumption we have given necessary and sufficient conditions for the existence of a linear state feedback which achieves regulation. There is only a very small gap between the necessary and the sufficient conditions. Moreover, we have shown that general nonlinear compensators in these cases cannot do better in our semi-global setting.

If this assumption is not satisfied then our conditions for both state and error feedback are still sufficient for the existence of a feedback with a linear structure which achieves regulation. However, nonlinear feedbacks might do better.

Appendix A: Uniqueness of Asymptotic Behavior of the Input

In this section we will prove that under rather weak assumptions the asymptotic behavior of the input is unique given that the output of the system tracks a certain reference signal. This is a result which is used in the proof of Theorem 5.1.

Theorem A.1: *Assume the system:*

$$\begin{cases} x^+ = Ax + Bv, \\ y = Cx + Dv \end{cases} \quad (\text{A.1})$$

with $x(0) = 0$ is given where (A, B, C, D) is left-invertible and has no invariant zeros on the unit circle. Moreover, assume v is bounded and such that $y(k) \rightarrow 0$ as $k \rightarrow \infty$. Finally, assume zero initial conditions. In that case $v(k) \rightarrow 0$ as $k \rightarrow \infty$.

Proof : Since we know the system Σ with realization (A, B, C, D) is left invertible and has no invariant zeros on the unit circle, we know there exists a left-inverse Σ_L with input-output operator G_L which has no poles on the unit circle. We split G_L into a stable and antistable part: $G_L = G_L^+ + G_L^-$ where G_L^+ has all poles outside the unit circle and G_L^- has all poles inside the unit circle. We know $v = Gy = G_L^+ y + G_L^- y$. Clearly since $y(k) \rightarrow 0$ as $k \rightarrow \infty$, we have that $(G_L^- y)(k) \rightarrow 0$ as $k \rightarrow \infty$. On the other hand, G_L^+ might not be causal. We write $G_L^+ = G_{L,c}^+ H$ where H only consists of backwards shifts in such a way that $G_{L,c}^+$ has only poles outside the unit circle and is causal. Moreover since H only consists of shift in time we know $z = Hy$ satisfies $z(k) \rightarrow 0$ as $k \rightarrow \infty$. Suppose we have a minimal realization (F, G, H, J) for $G_{L,c}^+$ where F has all eigenvalues outside the unit circle. Moreover, we know that the output of $G_{L,c}^+$, given the input z , is bounded since v is bounded. Since we have a minimal realization this implies that the state x of $G_{L,c}^+$ is bounded. We have:

$$x(k+T) = F^T \left(x(k) + \sum_{i=0}^{T-1} F^{i+1-T} Gz(k+i) \right) \quad (\text{A.2})$$

We find since F is antistable:

$$\left\| \sum_{i=0}^{T-1} F^{i+1-T} Gz(k+i) \right\| < M \|z\|_{\infty, k}$$

where M is independent of k and T . Assume there exists a time k such that

$$\|x(k)\| > M\|z\|_{\infty,k}.$$

Then from (A.2) we find that x is unbounded which yields a contradiction. Therefore:

$$\|x(k)\| < M\|z\|_{\infty,k} \rightarrow 0$$

as $k \rightarrow \infty$. But since also $z(k) \rightarrow 0$ as $k \rightarrow \infty$ we find that

$$u(k) = Hx(k) + Jz(k) \rightarrow 0$$

as $k \rightarrow \infty$. ■

References

- [1] B.A. Francis, "The linear multivariable regulator problem", *SIAM J. Contr. & Opt.*, Vol. 15, No. 3, pp. 486-505, 1977.
- [2] A.T. Fuller, "In-the-large stability of relay and saturating control systems with linear controller", *Int. J. Control*, Vol. 10, No. 4, pp. 457-480, 1969.
- [3] M. Hautus, "Linear matrix equations with applications to the regulator problem," in *Outils and Modèles Mathématique pour l'Automatique*, I.D. Landou, Ed. Paris: C.N.R.S., pp. 399-412, 1983.
- [4] Z. Lin, *Global and Semi-Global Control Problems for Linear Systems Subject to Input Saturation and Minimum-Phase Input-Output Linearizable Systems*, Ph.D Dissertation, Washington State University, May 1994.
- [5] Z. Lin, R. Mantri and A. Saberi, "Semi-global output regulation for linear systems subject to input saturation – a low-and-high gain design," to be presented at *1995 ACC*
- [6] Z. Lin and A. Saberi, "Semi-global exponential stabilization of linear systems subject to 'input saturation' via linear feedbacks", *Systems & Control Letters*, vol. 21, no. 3, pp. 225-239, 1993.
- [7] Z. Lin and A. Saberi, "Semi-global exponential stabilization of linear discrete-time systems subject to 'input saturation' via linear feedbacks", to appear in *Systems & Control Letters*.
- [8] Z. Lin and A. Saberi, "A low-and-high gain approach to semi-global stabilization and/or semi-global practical stabilization of a class of linear systems subject to input saturation via linear state and output feedback," *Proc. 32nd IEEE CDC*, 1993.
- [9] Z. Lin and A. Saberi, "A semi-global low-and-high gain design technique for linear systems with input saturation – stabilization and disturbance rejection," to appear in *International Journal of Robust and Nonlinear Control*.
- [10] Z. Lin, A.A. Stoorvogel and A. Saberi, "Output regulation for linear systems subject to input saturation," submitted to *Automatica*, 1994.

- [11] Z. Lin, A. Saberi and A. Stoorvogel, "Semi-global stabilization of linear discrete-time systems subject to input saturation via linear feedback - an ARE-based approach," submitted to *IEEE Transactions on Automatic Control*, 1994.
- [12] E.D. Sontag and H.J. Sussmann, "Nonlinear output feedback design for linear systems with saturating controls," *Proc. 29th IEEE Conf. Decision and Control*, pp. 3414-3416, 1990.
- [13] A.A. Stoorvogel, "Nonlinear L_1 optimal controllers for linear systems", February 1994, to appear in *IEEE Transactions on Automatic Control*.
- [14] H.J. Sussmann and Y. Yang, "On the stabilizability of multiple integrators by means of bounded feedback controls", *Proc. 30th CDC*, Brighton, U.K., pp. 70-72, 1991.
- [15] H.J. Sussmann, E.D. Sontag and Y. Yang, "A general result on the stabilization of linear systems using bounded controls", to appear in *IEEE Transactions on Automatic Control*.
- [16] A.R. Teel, "Global stabilization and restricted tracking for multiple integrators with bounded controls", *Systems & Control Letters*, Vol. 18, No.3, pp. 165-171, 1992.
- [17] A.R. Teel, *Feedback Stabilization: Nonlinear Solutions to Inherently Nonlinear Problems*, Ph.D dissertation, College of Engineering, University of California, Berkeley, CA, 1992.
- [18] A.R. Teel, "Semi-global stabilization of linear controllable systems with input nonlinearities," to appear in *IEEE Transaction on Automatic Control*.
- [19] W.M. Wonham, *Linear Multivariable Control: A Geometric Approach*, 2nd ed. New York: Springer-Verlag, 1979.
- [20] Y. Yang, *Global Stabilization of Linear Systems with Bounded Feedback*, Ph.D dissertation, New Brunswick Rutgers, the State University of New Jersey, 1993.