

Modeling of series-connected photovoltaic cells

TARABSHEH, A.A., ETIER, I., AKMAL, Muhammad <<http://orcid.org/0000-0002-3498-4146>>, SWELEH, A. and GHAZAL, M.

Available from Sheffield Hallam University Research Archive (SHURA) at:

<http://shura.shu.ac.uk/25018/>

This document is the author deposited version. You are advised to consult the publisher's version if you wish to cite from it.

Published version

TARABSHEH, A.A., ETIER, I., AKMAL, Muhammad, SWELEH, A. and GHAZAL, M. (2016). Modeling of series-connected photovoltaic cells. In: 2016 IEEE 43rd Photovoltaic Specialists Conference (PVSC). IEEE, 1523-1526.

Copyright and re-use policy

See <http://shura.shu.ac.uk/information.html>

Modeling of Series-Connected Photovoltaic Cells

A. Al Tarabsheh ^{1,2}, I. Etier ², M. Akmal ¹, M. Ghazal ¹, A. Sweleh ¹

¹ Abu Dhabi University, Electrical and Computer Engineering Department, 59911 Abu Dhabi, United Arab Emirates.

² The Hashemite University, Electrical Engineering Department, 13115 Zarqa, Jordan
Email: anas.altarabsheh@adu.ac.ae

Abstract—This paper proposes a new model for series-connected photovoltaic (PV) cells, using a modified one-diode equivalent-circuit model. The PV modules comprise many series-connected cells to generate more electrical power. This modified model starts with the conventional one-diode equivalent-circuit (parallel-connected current source with a diode and a shunt resistance which are connected in series with a series resistance and a load) of PV cells and then proposes a new way of connecting the aforementioned circuit elements. The advantage of the presented modified model, is that it can model the series-connected PV cells by a new representation of one-diode equivalent-circuit. To validate the results of the modified model, similar input variables are applied to the conventional and the presented models. The current/voltage (I/V) characteristics are then calculated from both models and compared. The results show that the difference between the calculated I/V characteristics using the two models is much less than 1 percent. The presented approach can thus, be very useful for researchers or engineers to quickly and easily determine the performance of PV modules

Index Terms—photovoltaic module, equivalent-circuit, current/voltage characteristics.

I. INTRODUCTION

When the light of an appropriate photon energy strikes the surface of photovoltaic (PV) cell is absorbed, electrons are released to circulate in a closed loop circuit through an external load. The resulted electric current continues as long as light strikes the PV cell. The load has an optimum value where the power generated from the PV cell is maximum [1], [2]. The PV modules comprise a number of series-connected PV cells in order to provide more power than just a single PV cell. Researchers and manufacturers of PV modules strive to achieve the highest possible electrical efficiency by characterizing and optimizing the fabrication parameters of the PV cells. One of the characterization methods applied for PV cells is the current/voltage (I/V) measurement which is used to derive the important electrical parameters of the PV modules [3], [4]. The parameters include the modules current (I_m) and voltage (V_m) at maximum-power point, open-circuit voltage (V_{oc}), short-circuit current (I_{ph}), and efficiency (η). Different models for PV cells have been investigated [5]-[10] to optimize new technologies and to study their behavior in different context. Recent advances in simulation methodologies, availability of software, and technical developments have made simulation one of the most widely used and accepted tools in system analysis and operation research. In this work,

we start by the conventional equivalent-circuit (CEC) of one PV cell [11], [12] shown in Figure 1 (a), where the current source, a diode, and parasitic resistors are included. The parallel resistance (R_p) reflects the leakage occurrence through the pn junction of the PV cell [13]. The electrical losses of the cells surface and bulk are represented by R_s . The current/voltage (I/V) relation [14]-[16] can be written as:

$$I = I_0 \left(\exp \left(\frac{V - IR_s}{n_{id} V_t} \right) - 1 \right) + \frac{V - IR_s}{R_p} - I_{ph} \quad (1)$$

Where I is the diodes (pn junction) current, I_0 is the reverse-saturation current, V_t is the thermal voltage [17] (equals 25 mV at 300 K), n_{id} is the ideality factor [18] that depends on the exact recombination mechanism, and I_{ph} is the maximum generated current (short-circuit current) from the PV cell. Figure 1 (b) shows the CEC of N -similar series-connected PV cells operating under the same ambient conditions.

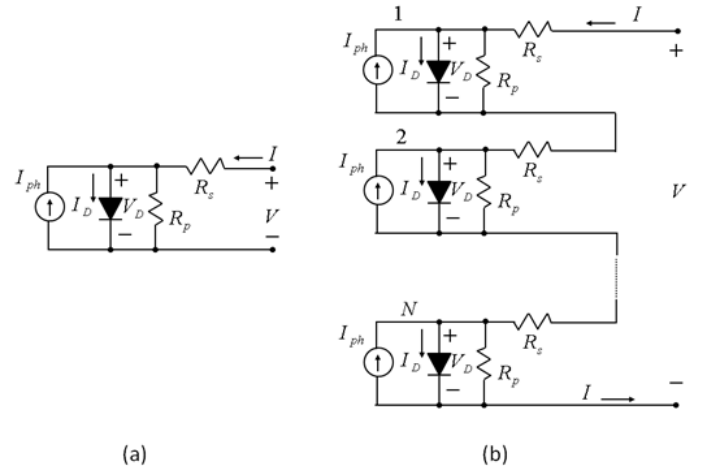

Fig. 1. Conventional equivalent-circuit (CEC) of (a) one PV cell and (b) N - series-connected PV cells.

II. ANALYSIS OF THE MODIFIED EQUIVALENT-CIRCUIT (MEC)

The ultimate object in this work is to simplify the CEC of N -series-connected PV cells. To combine the circuit elements of each PV cell, we modify the CEC of the PV

cell as shown in Figure 2 where the current/voltage (I/V) equation resulted from Figure 1 (a) should be identical to that of the circuit shown in Figure 2. Table I shows the current and voltage relationship in the conventional and the modified models.

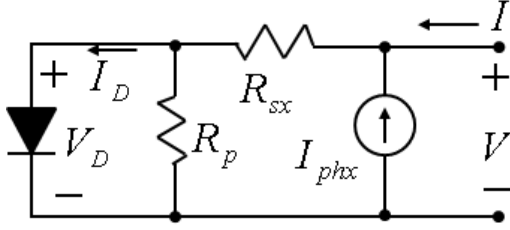

Fig. 2. A modified equivalent-circuit of one PV cell.

TABLE I
CURRENT AND VOLTAGE RELATIONSHIPS IN THE CONVENTIONAL AND THE MODIFIED MODELS OF PV CELL EQUIVALENT CIRCUITS

Equations of CEC model (Figure 1 a) :
$V = IR_s + (I + I_{ph} - I_D) R_p$ (2)
$I = \frac{V - V_D}{R_s}$ (3)
Equations of MEC model (Figure 2) :
$V = (I + I_{phx} - I_D) R_{sx} + (I + I_{ph} - I_D) R_p$ (4)
$V = \left(\frac{V_D}{R_p}\right) R_{sx} + V_D$ (5)
$I_D = I_0 \left(\exp\left(\frac{V - IR_s}{n_{id} V_t}\right) - 1 \right)$ (6)
$I = \left(\frac{V - V_D}{R_{sx}}\right) - I_{phx}$ (7)

By combining the previous equations of the two models, the following equations are valid:

$$I_{phx} = I_{ph} \quad (8)$$

and

$$R_{sx} = R_s \left(\frac{I}{I + I_{phx}} \right) \quad (9)$$

The voltage of the PV cell is therefore expressed as:

$$V = I_D R_{sx} \left(1 + \frac{R_{sx}}{R_p} \right) V_D \quad (10)$$

Figure 3 shows the modified equivalent-circuit (MEC) of the PV cell where it has one series resistance (R_s) while the parallel resistance (R_p) is included in the equivalent diodes voltage drop $\left(1 + \frac{R_{sx}}{R_p}\right) V_D$.

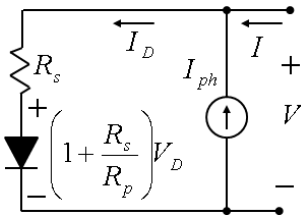

Fig. 3. Final modified equivalent-circuit (MEC) of one PV cell.

Figure 4 (a) shows the modified equivalent-circuit (MEC) of N -series-connected PV cells. Since the PV cells share the same current I_{ph} , it can be modeled in parallel with the combined series NR_{sx} and one large diode of a drop voltage equals $\left(1 + \frac{R_{sx}}{R_p}\right) V_D$ as shown in Figure 4 (b). The expressions for the voltage and the current of the PV module can then be expressed as:

$$V = NI_D R_{sx} \left(1 + \frac{R_{sx}}{R_p} \right) NV_D \quad (11)$$

$$I = I_D - I_{phx} \quad (12)$$

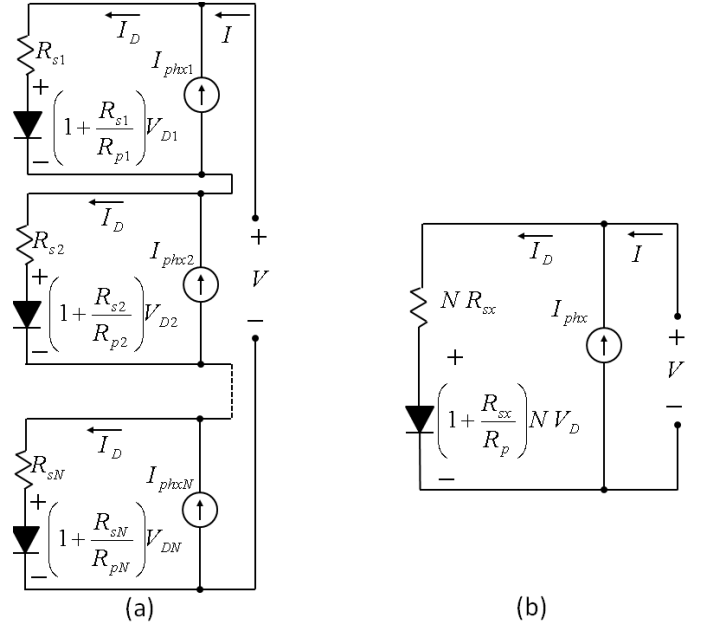

Fig. 4. Modified equivalent-circuit (MEC) of (a) N series-connected PV cells and (b) simplified circuit of the MEC model.

By combining the two equations in (10), the PV modules current/voltage equation is:

$$I = I_0 \left(\exp\left(\frac{V - I_D NR_{sx}}{N \left(1 + \frac{R_{sx}}{R_p}\right) n_{id} V_t}\right) - 1 \right) - I_{ph} \quad (13)$$

The conventional current/voltage equation for the PV modules is:

$$I = I_0 \left(\exp\left(\frac{V - IR_s}{n_{id} V_t}\right) - 1 \right) + \frac{V - IR_s}{R_p} - I_{ph} \quad (14)$$

III. EXPERIMENTAL TESTBED

To obtain appropriate data that can help in fortifying our approach. The experimental testbed which is depicted in Figure 5 was implemented. It consists of a mono crystalline PV module, which is provided with a constant light source

from a 300W light bulb. A fan is used to keep the module cold at 300K during the data acquisition period. A voltmeter is connected in parallel to the module, to measure the output voltage of the PV, while an ammeter is connected in series between the module and the load to measure the output current of the PV. The load comes in the form of a 500 ohm variable resistor, which is varied during the data acquisition period to obtain different values of current and voltage from the PV module

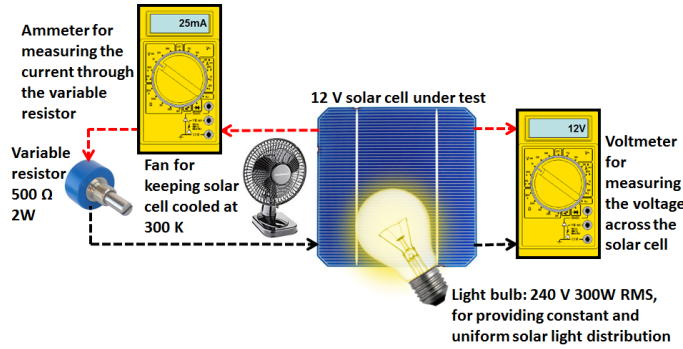

Fig. 5. Experimental Testbed for measuring I/V characteristics of PV module

IV. DISCUSSION AND RESULTS

To validate the modified model of the PV module equivalent-circuit, we measured real current voltage characteristics of a mono crystalline PV module consisting of $N = 18$ cells. The operating temperature of the setup is $T = 300K$ and the lamps have an $AM = 1.5$ -like spectrum. The measured data is modeled by the conventional model (14) and the modified model (13) by applying the fitting parameters depicted on Figure 6. each cell of the tested PV module has an area of 5 cm^2 .

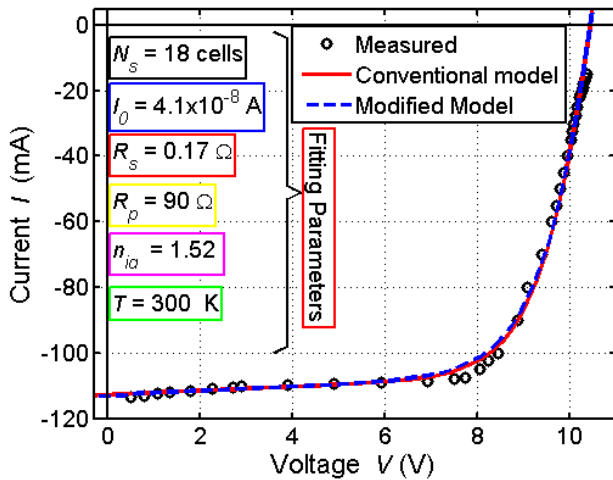

Fig. 6. Measured (circles) and Modeled I/V characteristics of a tested mono crystalline PV module using the conventional model (solid line) and the modified model (dashed line)

Figure 5 shows the good agreement between the modeled I/V characteristics of the tested PV module, using the conventional model and the modified model, with the measured data with an error less than 1%.

V. CONCLUSION

This paper presented a modified model for the one-diode equivalent-circuit of photovoltaic (PV) cells. The major advantage of this modified model is that it can represent the PV module (series-connected PV cells) as one one-diode equivalent-circuit. The current/voltage (I/V) characteristics are calculated by both modified model and the conventional one-diode equivalent-circuit with a difference of less than 1 percent. The modified model can be therefore used to as a new model for PV modules.

REFERENCES

- [1] S. Babaa, M. Armstrong, V. Pickert, "Overview of Maximum Power Point Tracking Control Methods for PV Systems", *Journal of Power and Energy Engineering* vol. 2, pp. 59-72, 2014.
- [2] M. Khalifa, K. Saied, S. Bitro, M. Anwar, M. Nizam, "PV Power System Using Maximum Power Point Tracking (Increment Conductance Algorithm)", *International Journal of Innovative Research in Science, Engineering and Technology* vol. 3, Issue 5, 2014.
- [3] S. Sera, R. Teodorescu, P. Rodriguez, "PV panel model based on data sheet values", *IEEE International Symposium on Industrial Electronics, ISIE 2007* vol. 4-7, pp. 2392-2396, 2007.
- [4] D. Bonkougou, Z. Koalaga, D. Njomo, "Modelling and Simulation of photovoltaic module considering single-diode equivalent circuit model in MATLAB", *International Journal of Emerging Technology and Advanced Engineering* Vol. 3, Issue 3, 2013.
- [5] W. B. Xiao, F. Y. Hu, H. M. Zhang, and H. M. Wu, "Experimental Investigation of the Effects of Partial Shading on Photovoltaic Cells Electrical Parameters", *International Journal of Photoenergy*, Article ID 191603, 7 pages, 2015.
- [6] A. Kumar, A. Parimi, K. Rao, "A Comparative Study of Model Based Design of PV cell in MATLAB/Simulink/Simscape", *International Journal of Advanced Trends in Computer Science and Engineering* vol. 3, No.1, pp. 37-42, 2014.
- [7] D. Sinha, A. Das, D. Dhak, P. Sadhu, "Equivalent circuit configuration for solar PV cell", *1st International Conference on Non-Conventional Energy*, Kalyani, India 16-17 January 2014.
- [8] L. Bay, K. West, "An equivalent circuit approach to the modelling of the dynamics of dye sensitized solar cells", *Solar Energy Materials and Solar Cells* vol. 87, pp. 613-628, 2005.
- [9] L. Castaer, S. Silvestre, *Modeling of photovoltaic cell using free software application for training and design circuit in photovoltaic solar energy*, John Wiley and sons LTD; 2002.
- [10] I. H. Altas and A. M. Sharaf, "Array simulation model for Matlab-Simulink GUI Environment", *European Photovoltaic Solar Energy Conference*, Glasgow, UK, 2000.
- [11] J. L. Gray, *The Physics of the Solar Cell*, in *Handbook of Photovoltaic Science and Engineering*, Editor, John Wiley and Sons., 2011.
- [12] P.-C. Hsu, "Modelling of solar cells and modules using piecewise linear parallel branches", *Renewable Power Generation, IET* vol. 5, Issue 3, pp. 215-222, 2011.
- [13] A. Al Tarabsheh, I. Etier, M. Widyana, "Investigating the Shunting Effects of Parallel-Connected A-Si:H Solar Cells", *International Journal of Sustainable Energy*, Published online DOI:10.1080/14786451.2011.592587, ISSN 1478-6451 print/ISSN 1478-646X online, pp. 1-7, 2011.

- [14] S. Chander , A. Purohit , A. Sharma, Arvindc, S.P. Nehra , M.S. Dhaka, "A study on photovoltaic parameters of mono-crystalline silicon solar cell with cell temperature", *Energy Reports* vol. 1, pp. 104109, 2015.
- [15] V. Sharma, S.S. Chandel, "Performance and degradation analysis for long term reliability of solar photovoltaic systems: A review", *Renewable and Sustainable Energy Reviews*, pp. 27 753767, 2013.
- [16] U. Wuerfel, D. Neher, A. Spies, S. Albrecht, " Impact of charge transport on currentvoltage characteristics and power-conversion efficiency of organic solar cells", *Nature Commu-nications*, 6:6951, DOI: 10.1038/ncomms7951, 2015.
- [17] W. De Soto, S. A. Klein, " Improvement and validation of a model for photovoltaic array performance", *Solar Energy* vol. 80, pp. 78-88, 2006.
- [18] A. Al Tarabsheh, " Description of the Ideality Factor of a-Si:H Photovoltaic Cells Under Different Illumination Intensity Levels", *Journal of Renewable and Sustainable Energy*, vol. 7, Issue, 2, 2015.
- [19] S. Kim, J.H. Jeon, C.H.Cho, E.S.Kim, J.B. Ahn, "Modeling and simulation of a grid-connected PV generation system for electromagnetic transient analysis", *Solar Energy* vol. 83, pp. 664678, 2009.
- [20] P. Singh, N.M. Ravindra., "Temperature dependence of solar cell performancean analysis", *Solar Energy Materials and Solar Cells* vol. 101, pp. 3645, 2012.