

THE CLASSIFICATION OF SOME FUZZY SUBGROUPS OF FINITE GROUPS
UNDER A NATURAL EQUIVALENCE AND ITS EXTENSION, WITH
PARTICULAR EMPHASIS ON THE NUMBER OF EQUIVALENCE CLASSES.

A thesis submitted in fulfillment of the requirements for the degree of

MASTER OF SCIENCE IN MATHEMATICS

In the Faculty of Science and Agriculture at the University of Fort Hare

BY

ODILO NDIWENI

24 October 2007

Name of Supervisor:

Prof BB Makamba

Abstract

In this thesis we use the natural equivalence of fuzzy subgroups studied by Murali and Makamba [25] to characterize fuzzy subgroups of some finite groups. We focus on the determination of the number of equivalence classes of fuzzy subgroups of some selected finite groups using this equivalence relation and its extension.

Firstly we give a brief discussion on the theory of fuzzy sets and fuzzy subgroups. We prove a few properties of fuzzy sets and fuzzy subgroups. We then introduce the selected groups namely the symmetric group S_3 , dihedral group D_4 , the quaternion group Q_8 , cyclic p-group $G = \mathbb{Z}_{p^n}$, $G = \mathbb{Z}_{p^n} + \mathbb{Z}_{q^m}$, $G = \mathbb{Z}_{p^n} + \mathbb{Z}_{q^m} + \mathbb{Z}_r$ and $G = \mathbb{Z}_{p^n} + \mathbb{Z}_{q^m} + \mathbb{Z}_{r^s}$ where p, q and r are distinct primes and $n, m, s \in \mathbb{N}$.

We also present their subgroups structures and construct lattice diagrams of subgroups in order to study their maximal chains. We compute the number of maximal chains and give a brief explanation on how the maximal chains are used in the determination of the number of equivalence classes of fuzzy subgroups. In determining the number of equivalence classes of fuzzy subgroups of a group, we first list down all the maximal chains of the group. Secondly we pick any maximal chain and compute the number of distinct fuzzy subgroups represented by that maximal chain, expressing each fuzzy subgroup in the form of a keychain. Thereafter we pick the next maximal chain and count the number of equivalence classes of fuzzy subgroups not counted in the first chain. We proceed inductively until all the maximal chains have been exhausted. The total number of fuzzy subgroups obtained in all the maximal chains represents the number of equivalence classes of fuzzy subgroups for the entire group, (see sections 3.2.1, 3.2.2, 3.2.6, 3.2.8, 3.2.9, 3.2.15, 3.16 and 3.17 for the case of selected finite groups).

We study, establish and prove the formulae for the number of maximal chains for the groups $G = \mathbb{Z}_{p^n} + \mathbb{Z}_{q^m}$, $G = \mathbb{Z}_{p^n} + \mathbb{Z}_{q^m} + \mathbb{Z}_r$ and $G = \mathbb{Z}_{p^n} + \mathbb{Z}_{q^m} + \mathbb{Z}_{r^s}$ where p, q and r are distinct primes and $n, m, s \in \mathbb{N}$. To accomplish this, we use lattice diagrams of subgroups of these groups to identify the maximal chains. For instance, the group $G = \mathbb{Z}_{p^n} + \mathbb{Z}_{q^m}$ would require the use of a 2- dimensional rectangular diagram (see section 3.2.18 and 5.3.5), while for the group $G = \mathbb{Z}_{p^n} + \mathbb{Z}_{q^m} + \mathbb{Z}_{r^s}$ we execute 3- dimensional lattice diagrams of subgroups (see section 5.4.2, 5.4.3, 5.4.4, 5.4.5 and 5.4.6). It is through these lattice diagrams that we identify routes through which to carry out the extensions. Since fuzzy subgroups represented by maximal chains are viewed as keychains, we give a brief discussion on the notion of keychains, pins and their extensions. We present propositions and proofs on why this counting technique is justifiable. We derive and prove formulae for the number of equivalence classes of the groups $G = \mathbb{Z}_{p^n} + \mathbb{Z}_{q^m}$, $G = \mathbb{Z}_{p^n} + \mathbb{Z}_{q^m} + \mathbb{Z}_r$ and $G = \mathbb{Z}_{p^n} + \mathbb{Z}_{q^m} + \mathbb{Z}_{r^s}$ where p, q and r are distinct primes and $n, m, s \in \mathbb{N}$. We give a detailed explanation and illustrations on how this keychain extension principle works in Chapter Five. We conclude by giving specific illustrations on how we compute the number of equivalence classes of a fuzzy subgroup for the group $G = \mathbb{Z}_{p^2} + \mathbb{Z}_{q^2} + \mathbb{Z}_{r^2}$ from the number of fuzzy subgroups of the group $G_1 = \mathbb{Z}_{p^2} + \mathbb{Z}_{q^2} + \mathbb{Z}_r$. This illustrates a general technique of computing the number of fuzzy subgroups of

$G = \mathbb{Z}_{p^n} + \mathbb{Z}_{q^m} + \mathbb{Z}_{r^s}$ from the number of fuzzy subgroups of $G_1 = \mathbb{Z}_{p^n} + \mathbb{Z}_{q^m} + \mathbb{Z}_{r^{s-1}}$.
Our illustration also shows two ways of extending from a lattice diagram of G_1 to that of G .

KEY WORDS:

Fuzzy Subgroups, normal fuzzy subgroups, maximal chains, equivalent fuzzy subgroups, keychains, node and pin extension.

CONTENTS

	PAGE
Abstract	2
Acknowledgement	6
Introduction	7
Chapter 1: Fuzzy Sets, Fuzzy Subgroups, Fuzzy Normal Subgroups	
1.0 Introduction	12
1.1 Fuzzy Sets	12
1.2 Fuzzy Subgroups	16
1.3 Fuzzy Normal Subgroups	21
Chapter 2: Fuzzy Equivalence Relations and Fuzzy Isomorphism	
2.0 Introduction	25
2.1 An equivalence relation	25
2.2 Fuzzy relations	25
2.3 Fuzzy equivalence relation	26
2.4 Fuzzy isomorphism	28
Chapter 3: On Equivalence of Fuzzy Subgroups, Isomorphic Classes of Fuzzy Subgroups of selected finite groups.	
3.0 Introduction	31
3.1 Equivalent Fuzzy Subgroups	31
3.2 Classification of Fuzzy Subgroups of Finite groups	32
3.3 Isomorphic Classes of Fuzzy Subgroups	47
Chapter 4: On the Maximal chains of the groups $G = \mathbb{Z}_{p^n} + \mathbb{Z}_{q^m}$ and $G = \mathbb{Z}_{p^n} + \mathbb{Z}_{q^m} + \mathbb{Z}_{r^s}$	
4.0 Introduction	51
4.1 Maximal Chains of $G = \mathbb{Z}_{p^n} + \mathbb{Z}_{q^m}$	51

4.1.5 Maximal chains of $G = \mathbb{Z}_{p^n} + \mathbb{Z}_{q^m}$	52
4.2 Maximal chains of $G = \mathbb{Z}_{p^n} + \mathbb{Z}_{q^m} + \mathbb{Z}_{r^s}$	57

**Chapter 5: On the Number of equivalence classes of Fuzzy Subgroups for
the groups $G = \mathbb{Z}_{p^n} + \mathbb{Z}_{q^m}$ and $G = \mathbb{Z}_{p^n} + \mathbb{Z}_{q^m} + \mathbb{Z}_{r^s}$**

5.0 Introduction	70
5.1 Keychains and pin-extensions	70
5.2 Justification of the Counting technique of Fuzzy Subgroups	74
5.3 Classification of fuzzy subgroups of $G = \mathbb{Z}_{p^n} + \mathbb{Z}_{q^m}$	83
5.4 Classification of fuzzy subgroups of $G = \mathbb{Z}_{p^n} + \mathbb{Z}_{q^m} + \mathbb{Z}_r$	91
5.5 Conclusion	114
References	131

Acknowledgements

I owe gratitude to Prof BB Makamba not only for patiently mentoring me throughout the course of my studies but also affording me financial assistance by offering me a tutorship position in the department, for this I am deeply indebted to him.

I also thank very much Prof S. Mabizela and Prof V. Murali for helping me access the Rhodes University Library.

Many thanks also go to members of staff at the Department of Mathematics at the University of Fort Hare for their invaluable support and encouragement during my study.

Finally I thank God for making it possible for to undertake this research, and for giving me the determination to complete my studies.

Introduction

Human beings barely comprehend quantitatively some decision-making and problem-solving tasks that are complex, hence the need for the execution of knowledge that is imprecise to reach definite decisions. This has led to the advent of fuzzy set theory thought to resemble human reasoning in its use of approximate data and uncertainty in the generation of decisions. Although Fuzzy Logic dates back to Plato, Lukaieviz (1900s) at some stage referred to it as Many-Valued logic, it was formalized by Pofessor Lotfi Zadeh in the 1960s. The term Fuzzy Logic is embracive as it is used to describe the likes of fuzzy arithmetic, fuzzy mathematical programming, fuzzy topology, fuzzy logic, fuzzy graph theory and fuzzy data analysis which are customarily called Fuzzy set theory.

This theory of fuzzy subsets as developed by Zadeh L. has a wide range of applications, for example it has been used by Rosenfield in 1971 to develop the theory of fuzzy groups. Other notions have been developed based on this theory , these include among others , the notion of level subgroups by P.S. Das used to characterize fuzzy subgroups of finite groups and the notion of Equivalence of fuzzy subgroups introduced by Makamba and Murali which will be used in this thesis. In this thesis we use this natural equivalence to study the characterization of some finite groups, we compare the number of equivalence classes and isomorphic classes of these specific groups.

It was in 1971 that Rosenfeld [34] first published his work on fuzzy groups. P.S. Das [11], Mukherjee and Bhattacharya [7] followed a decade later. The latter characterized fuzzy subgroups executing the notions of fuzzy cosets and fuzzy normal subgroups. Das [11] introduced level subgroups and characterized fuzzy subgroups of finite groups by their level subgroups, he proved that they form a chain. He raised the problem of finding a fuzzy subgroup that is representative of all the level subgroups. This problem was answered by Bhattacharya [5], he managed to show that given any chain of subgroups of a finite group there exists a fuzzy subgroup of that group whose level subgroups are precisely the members of that finite chain. An important discovery by [5] was that this fuzzy subgroup is not unique, in other words two distinct fuzzy subgroups can have the same family of level subgroups. We use this characterization in this thesis. The same author in [6] proves that two fuzzy

subgroups of finite groups with identical level subgroups are equal if and only if their image sets are equal. Bhattacharya in [6] also generalized Rosenfeld [34, *Theorem...5.10*] and Das [11, *Theorem...5.2*].

Fuzzy normality was introduced by Bhattacharya and Mukherjee in [7]. Several studies on the concept have been done by [2], [3], [11], [17], [20] and [22] just to mention a few. For instance Akgul [2] studied fuzzy normality, fuzzy level normal subgroups and their homomorphism. Makamba and Murali in [22] proved that normal fuzzy subgroups and congruence relations determine each other in a group theoretical sense.

Sherwood [38] introduced the concept of external direct product of fuzzy subgroups. Makamba [21] introduced the concept of internal direct product and proved that both are isomorphic if the fuzzy subgroups are fuzzy normal.

Rosenfeld [34] proved that a homomorphic image of a fuzzy subgroup is a fuzzy subgroup provided the fuzzy subgroup has a sup-property, while a homomorphic pre-image of a fuzzy subgroup is always a fuzzy subgroup. Anthony and Sherwood [3] later proved that even without the sup-property the homomorphic image of a fuzzy subgroup is a fuzzy subgroup.

Other studies on homomorphic images and pre-images of fuzzy subgroups were done by Sidky and Mishref, Kumar [19], Abou-Zaid [1], Makamba [20] and Murali [24].

The notion of a fuzzy relation was first defined on a set by Zadeh [39,40], further studies were accomplished by Rosenfeld [34] and Kaufmann [16]. Formato, Scarpati and Gerla [14] and Zadeh [40] also studied similarity relation, which we do not pursue in this thesis. Chakraborty and Das [9,10] studied fuzzy relation in connection with equivalence relations and fuzzy functions. Murali and Makamba [25,26,27,28] instead studied fuzzy relations in connection with partitions and derived a suitable natural equivalence relation on the class of all fuzzy sets of a set. This they used to characterize and determine the number of distinct equivalence classes of fuzzy subgroups of p-groups. Murali and Makamba in [26] characterize fuzzy subgroups of some finite groups by use of keychains. The same authors in [27] introduced the notion of a pinned flag in order to study the operations sum, union and intersection in relation to this natural equivalence.

There have been a number of studies involving the use of this equivalence relation, see for example Murali and Makamba [28,29] and Ngcibi [30].

In Chapter 1 we define a fuzzy set in general and characterize fuzzy sets using α -cuts. We introduce the notion of a fuzzy subgroup and give a few properties of fuzzy subgroups. We give the definition of a product of fuzzy subgroups as given by Zadeh [39] and Makamba [20]. We also study fuzzy normality, its characterization by level subgroups and fuzzy points. We conclude the Chapter by proving that if μ is a fuzzy subgroup of a group then the homomorphic image $f(\mu)$ and homomorphic pre-image are fuzzy subgroups of the same group.

In Chapter 2 the notion of a fuzzy equivalence relation is introduced (see Murali [24], Murali and Makamba [25], [26], [27], Ngcibi [30]). In [24] Murali defined and studied properties, including cuts, of fuzzy equivalence relations on a set. It is the natural equivalence relation introduced by Murali and Makamba (for more details see [25], [26] and [27]) that we are going to extensively use in this thesis. We give this definition (given also by Murali and Makamba) and show that it is indeed an equivalence relation. We also define a t -norm, characterize a t -norm that is continuous and briefly discuss the usefulness of t -norm. A brief discussion on the equivalence of fuzzy subgroups and some consequences is given in this chapter. Specific examples are given on equivalent and non-equivalent fuzzy subgroups. We characterize equivalence between fuzzy subgroups using level subgroups. We conclude the chapter with a brief discussion on homomorphic images and pre-images.

Fraleigh [13] characterizes finite Abelian groups in the crisp case. Murali and Makamba in [25], [26] and [27] studied the classification of fuzzy subgroups of finite Abelian groups using different approaches that include the number of non-equivalent fuzzy subgroups for the group Z_{p^n} and $G = Z_{p^n} + Z_q$ where p and q are distinct primes, in [25]. In [26] they investigated the number of fuzzy subgroups of $G = Z_{p^1} + Z_{p^2} + \dots + Z_{p^n}$ for distinct primes p_i for $i = 1, 2, 3, \dots, n$ and also distinct fuzzy subgroups of $G = Z_{p^n} + Z_{q^m}$, where p and q are distinct primes, $n \in \mathbb{N}$ and

$m = 1, 2, 3, 4, 5$ were also studied. Ngcibi [30] also used the notion of equivalence of fuzzy subgroups studied by Murali and Makamba to characterize fuzzy subgroups of p -groups for specified primes p . The author [30] also did a classification of fuzzy subgroups of Abelian groups of the form $G = \mathbb{Z}_{p^n} + \mathbb{Z}_p$ and of the form $G = \mathbb{Z}_{p^n} + \mathbb{Z}_{q^m}$ for the cases $n = m$ and $n \neq m$.

In Chapter 3 we introduce some specific groups, namely the symmetric group S_3 , dihedral group D_4 , the quaternion group Q_8 , cyclic p -group $G = \mathbb{Z}_{p^n}$ and the group $G = \mathbb{Z}_{p^n} + \mathbb{Z}_{q^m}$. We present subgroups, lattice structure of subgroups and maximal chains. It is in this chapter that we give the definition of fuzzy isomorphism given by Murali and Makamba [25], we determine the number of distinct fuzzy subgroups and isomorphic classes of fuzzy subgroups for these groups. Comparisons are made on the number of distinct fuzzy subgroups and the number of isomorphic classes. Formulae for the number of distinct fuzzy subgroups for selected groups given by Murali and Makamba in [25], [26] and [27] and Ngcibi [30] are also verified on these groups we are studying.

In Chapter 4 we define a maximal subgroup of a group and demonstrate with a few lattice diagrams the determination of the number of maximal chains. We establish and give proofs, in the form of lemmas and propositions, of formulae for the number of maximal chains for the groups $G = \mathbb{Z}_{p^n} + \mathbb{Z}_{q^m}$, $G = \mathbb{Z}_{p^n} + \mathbb{Z}_{q^m} + \mathbb{Z}_r$ and $G = \mathbb{Z}_{p^n} + \mathbb{Z}_{q^m} + \mathbb{Z}_{r^s}$ where p, q, r are distinct primes and $n, m, s \in \mathbb{N}$.

Chapter 5 is an extension of chapter 4. Having obtained the formulae for the number of maximal chains for the groups, we go further on and introduce the notions of keychains, pins, pinned-flag (for more see Murali and Makamba [25], [26] and [27]) and pin extension which we exploit in the computation of the number of equivalence classes of fuzzy subgroups for these groups. We give a detailed explanation of the method of computing the number of fuzzy subgroups using maximal chains. This we accomplish by stating the counting technique in terms of propositions. Specific examples are given to illustrate how the counting technique is applied.

In 5.1.3.1 we include some work by Ngcibi [30] on the formulae for the distinct number of fuzzy subgroups for the group $G = \mathbb{Z}_{p^n} \times \mathbb{Z}_{q^m}$ where p, q are distinct primes and $m = 1, 2, 3$. We also give a proof of Ngcibi's Theorem 5.3.3 in [30] which the author did not prove. This we do as another illustration for the justification of our counting technique. We list a few combinatorial analysis definitions that are used in this proof. (for more see Riordan [36]). We establish and give proof, with an aid of 3-dimensional lattice diagrams, of formulae for the number of distinct fuzzy subgroups of the group $G = \mathbb{Z}_{p^n} \times \mathbb{Z}_{q^m} \times \mathbb{Z}_{r^s}$ where p, q, r are distinct primes and $n \in \mathbb{N}, m = 1, s = 1, 2, 3$ and 4.

We conclude by showing how in general the number of distinct fuzzy subgroups of $G = \mathbb{Z}_{p^n} \times \mathbb{Z}_{q^m} \times \mathbb{Z}_{r^s}$ can be obtained if the number of distinct fuzzy subgroups of $H = \mathbb{Z}_{p^n} + \mathbb{Z}_{q^m} + \mathbb{Z}_{r^{s-1}}$ (or $\mathbb{Z}_{p^n} + \mathbb{Z}_{q^{m-1}} + \mathbb{Z}_{r^s}$ or $\mathbb{Z}_{p^{n-1}} + \mathbb{Z}_{q^m} + \mathbb{Z}_{r^s}$) is known, illustrating with a specific case.

CHAPTER ONE

Fuzzy Sets, Fuzzy Subgroups, Fuzzy Normal Subgroups

1.0 Introduction

In order to study fuzzy subgroups, the theory of fuzzy sets is extended and applied to the group structural settings. In this topic we give a preliminary discussion on the general properties of fuzzy sets and characterize fuzzy sets using alpha- cuts. The notion of fuzzy subgroups as defined by Rosenfeld [34] is given and a few properties of fuzzy subgroups proved. Zadeh [39] and Makamba [20] defined the product of two fuzzy subgroups, this definition is given in this chapter. The notion of level subgroups has been used by several researchers in the classification of fuzzy subgroups, including among others, Das [11], Bhattacharya [6], and Makamba [20]. Fuzzy normality is studied and characterized using level subgroups and fuzzy points. We conclude by proving that if μ is a fuzzy subgroup of a group G then the homomorphic image $f(\mu)$ and homomorphic pre- image are fuzzy subgroups of the same group. Similar results were obtained by Rosenfeld [34], Kumar [19] and Makamba [20].

1.1 Fuzzy sets

A fuzzy set is a set derived by generalizing the concept of crisp set. Unlike in crisp set theory where there is total membership, say x belongs to a set U written as $x \in U$, fuzzy sets allow elements to partially belong to a set.

A fuzzy subset of a set U is a function

$$\mu : U \rightarrow [0,1] .$$

If the image set is $\{0,1\}$ then we have a crisp set. We sometimes represent the fuzzy set $\mu : A \rightarrow [0,1]$ by μ_A where $\mu_A(x) = t$ for $x \in A$, $0 \leq t \leq 1$. We then say t is the degree to which x belongs to the fuzzy subset μ_A .

We observe that when $t = 0$, we mean absolute non-membership, and when $t = 1$, absolute membership. If $0 \leq \mu(x) < \mu(y) \leq 1$ then we say y belongs to μ more than x belongs to μ .

1.1.1 Operations on Fuzzy sets

***Union of two fuzzy sets μ_A and μ_B called the Maximum Criterion, is defined as

$$\mu_{A \cup B} = \max(\mu_A, \mu_B) = \mu_A \vee \mu_B$$

***Intersection of two fuzzy sets μ_A and μ_B called the Minimum Criterion, is defined

$$\text{as } \mu_{A \cap B} = \min(\mu_A, \mu_B) = \mu_A \wedge \mu_B$$

***Complement of μ_A is defined as

$$\mu_{A^c}(x) = 1 - \mu_A(x)$$

***Inclusion

Fix a set U . Suppose μ and ν are two fuzzy sets, $\mu : U \rightarrow I, \nu : U \rightarrow I$, then by

$\mu \subseteq \nu$ we mean $\mu(x) \leq \nu(x) \quad \forall x \in U$.

***Equality

$$\mu = \nu \Leftrightarrow \mu(x) = \nu(x), \forall x \in U.$$

***Null set

Is described by the membership function $\mu_\emptyset(x) = 0, \forall x \in U$.

***Whole set

Is the fuzzy set $\mu_U(x) = 1, \forall x \in U$.

$$\vee \{\mu_j(x) : j \in J\} = \sup_{j \in J} \mu_j(x) \quad \text{and} \quad \wedge \{\mu_j(x) : j \in J\} = \inf_{j \in J} \mu_j(x)$$

1.1.2 Fuzzy Points

Consider a non-empty universal set U . The set of all fuzzy subsets of U is denoted by I^U .

Definition 1.1.3[20]

A fuzzy subset $\mu : X \rightarrow I$ is called a fuzzy point if $\mu(x) = 0, \forall x \in X$ except for one and only one element of X .

1.1.4 Consequences of definition 1.1.3

Firstly $\mu(x) \neq 0$ for one and only one element of X .

Consider $a \in X : \mu(a) \neq 0$. Then $\mu(a) = \lambda, 0 < \lambda \leq 1$ by the definition of $\mu(x)$.

Case I: If $\lambda = 1$ then $\mu(x) = 1$ when $x = a$ and 0 when $x \neq a$, the fuzzy set is the crisp singleton $\{a\}$

Case II: If $0 < \lambda < 1$ then $\mu(x) = \lambda$ when $x = a$ and 0 otherwise 1.1.3.1 (b)

Thus μ is a fuzzy point and we denote it by a^λ .

So a^λ is such that $a^\lambda(x) = \lambda$ if $x = a$ and 0 if $x \neq a$, this implies that

$$a^\lambda(a) = \lambda \tag{1.1.3.1(c)}$$

From 1.1.3.1(c) suppose $0 < \lambda^1 < \lambda^2 < \lambda \leq 1$ then $a^{\lambda^1} \subseteq a^{\lambda^2} \subseteq a^\lambda$

Proposition 1.1.5[20]

Let $\mu \in I^X$ Then $\mu = \vee \{a^\lambda : a^\lambda \in \mu\}$

1.1.6 On α -cuts

Consider a fuzzy set $\mu : X \rightarrow I = [0,1]$ and $0 \leq \alpha \leq 1$.

Definition 1.1.7 [30]

The weak α -cut of μ denoted by μ_α is defined as

$$\mu_\alpha = \{x \in X : \mu(x) \geq \alpha\}$$

Definition 1.1.8[30]

The strong α -cut of μ denoted by μ^α is defined as

$$\mu^\alpha = \{x \in X : \mu(x) > \alpha\}$$

***Consequences of definitions 1.1.7 and 1.1.8

$$(a) \alpha = 1 \Rightarrow \mu^\alpha = \phi$$

$$(b) \alpha = 0 \Rightarrow \mu_\alpha = X$$

Definition 1.1.9[20]

The Support of μ is defined as follows

$$Supp\mu = \{x \in X : \mu(x) > 0\}$$

1.1.10 Characterization of fuzzy sets using α -cuts

A fuzzy set can be characterized using α -cuts as the following proposition shows.

Proposition 1.1.11

Given any fuzzy set μ then $\mu = \sup_{0 < \alpha < 1} \alpha \chi_{\mu_\alpha} = \int_0^1 \alpha \chi_{\mu_\alpha} dx$

$$\text{or } \mu = \bigvee_{\alpha \in (0,1)} \alpha \chi_{\mu_\alpha} = \bigvee_{\alpha \in (0,1)} \alpha \chi_{\mu_\alpha}$$

Proof

Let $\mu(x) = \alpha_1$, then $x \in \mu_{\alpha_1} \Rightarrow \alpha_1 \chi_{\mu_{\alpha_1}}(x) = \alpha_1 = \mu(x)$.

Now if $\beta > \mu(x)$, then $x \notin \mu_\beta$

$$\Rightarrow \beta \chi_{\mu_\beta}(x) = 0, \text{ thus } \mu(x) = \alpha_1 \chi_{\mu_{\alpha_1}}(x) = \sup_{0 \leq \alpha \leq 1} \alpha \chi_{\mu_\alpha}(x) = \sup_{0 \leq \alpha \leq 1} \alpha \chi_{\mu_\alpha}(x). \quad \square$$

Also given any fuzzy set μ , $\mu(x) = \int_0^1 \alpha \chi_{\mu_\alpha}(x) dx$

Proof

Let $\mu(x) = \alpha$, then $\mu(x) = \alpha \chi_{\mu_\alpha}(x)$

$$= \alpha \chi_{\mu_\alpha}(x) \int_0^1 dx \text{ since } x \in \mu_\alpha.$$

Therefore $\mu(x) = \int_0^1 \alpha \chi_{\mu_\alpha}(x) dx$. □

1.1.12 Chains of α – cuts

Suppose $0 < \alpha < \beta < 1$ then $\mu^\alpha \supseteq \mu^\beta$ and also $\mu_\alpha \supseteq \mu_\beta$. Consequently given a chain of numbers

$$0 \leq \lambda_n \leq \lambda_{n-1} \leq \dots \leq \lambda_2 \leq \lambda_1 \leq 1, \text{ we have } \mu_{\lambda_1} \subseteq \mu_{\lambda_2} \subseteq \dots \subseteq \mu_{\lambda_{n-1}} \subseteq \mu_{\lambda_n} .$$

1.1.13 Images and pre-images of fuzzy sets [27]

Consider X and Y to be two universal non-empty sets and $f : X \rightarrow Y$ be a function from X to Y and let $\mu : X \rightarrow I$ be a fuzzy subset of X .

By $f(\mu)$ we mean a fuzzy set of Y defined by

$$f(\mu)(y) = \begin{cases} \sup\{\mu(x) : x \in f^{-1}(y)\} \\ 0, \text{ if } x \notin f^{-1}(y) \end{cases}$$

Thus the degree to which y belongs to $f(\mu)$ is at least as much as the degree to which x belongs to μ , $\forall x$ for which $f(x) = y$.

Definition: 1.1.13.1 [27]

Let $f : X \rightarrow Y$ be a function.

If ν is a fuzzy subset of Y then the pre-image $f^{-1}(\nu)$ is a fuzzy subset of X defined by $f^{-1}(\nu)(g) = \nu(f(g))$, $g \in X$.

1.2 Fuzzy Subgroups [23]

A fuzzy subset $\mu : G \rightarrow I$ of a group G is a fuzzy subgroup of G if

- (i) $\mu(xy) \geq \min\{\mu(x), \mu(y)\}, \forall x, y \in G$
- (ii) $\mu(x^{-1}) = \mu(x), \forall x \in G$

For the identity element $e \in G$, $\mu(x) \leq \mu(e), \forall x \in G$

Equivalently we have

Proposition: 1.2.0

A fuzzy subset μ of G is a fuzzy subgroup of G iff

(a) $\mu \circ \mu \leq \mu$ and

(b) $\mu^{-1} = \mu$ where μ^{-1} is defined as $\mu^{-1} : G \rightarrow I, \forall g \in G, \mu^{-1}(g) = \mu(g^{-1})$.

Before we give a proof of the above proposition we first give two important definitions

Definition: 1.2.1 [24]

We define $\mu \circ \mu(g) = \sup_{g=g_1g_2} (\mu(g_1) \wedge \mu(g_2))$

Definition: 1.2.2 [23]

If μ is a fuzzy subgroup on a group G and θ is a map from G onto itself, we define a map $\mu^\theta : G \rightarrow [0,1]$ by

$$\mu^\theta(g) = \mu(g^\theta), \forall g \in G$$

where g^θ is the image of g under θ .

Proof of (a)

(\Rightarrow)

Let $g_1, g_2 \in G$ be arbitrary, now since μ is a fuzzy subgroup of G ,

$$\mu(g_1g_2) \geq \mu(g_1) \wedge \mu(g_2), \text{ set } g = g_1g_2$$

Taking the supremum over both sides we obtain

$$\sup_{g=g_1g_2} (\mu(g)) \geq \sup_{g=g_1g_2} (\mu(g_1) \wedge \mu(g_2))$$

$$\Rightarrow \mu(g) \geq \vee_{g=g_1g_2} (\mu(g_1) \wedge \mu(g_2)) = \mu \circ \mu$$

Therefore $\mu \circ \mu \leq \mu$

$$(b) \mu \text{ is a fuzzy subgroup} \Rightarrow \mu(g) = \mu(g^{-1}), \forall g \in G$$

But by definition $\mu(g^{-1}) = \mu^{-1}(g), \forall g \in G$

Therefore $\mu^{-1} = \mu$.

(\Leftarrow) if $\mu \circ \mu = \mu$ and $\mu^{-1} = \mu$, we need to show that μ is a fuzzy subgroup.

Now $\mu \circ \mu(xy) \leq \mu(xy), \forall x, y \in G$ and $\mu \circ \mu(xy) = \sup_{xy=ab} \{\mu(a) \wedge \mu(b)\}$

$$\geq \min\{\mu(x), \mu(y)\} \quad \forall x, y \in G.$$

$$\Rightarrow \mu(xy) \geq \min\{\mu(x), \mu(y)\}.$$

Since $\mu(g) = \mu^{-1}(g) \quad \forall g \in G$ and $\mu^{-1}(g) = \mu(g^{-1}) \quad \forall g \in G$, then it follows that

$$\mu(g) = \mu(g^{-1}) \quad \forall g \in G. \quad \text{Therefore } \mu \text{ is a fuzzy subgroup of } G. \quad \square$$

Definition 1.2.3[11]

Let G be a group and μ be a fuzzy subgroup of G . The subgroups

$\mu_t, t \in [0,1]$ and $t \leq (e)$ are called level subgroups of G .

Definition 1.2.4[20]

Let μ and ν be fuzzy subsets of G . The product $\mu\nu : G \rightarrow [0,1]$ is defined by

$$\mu\nu(x) = \sup_{x=x_1x_2} (\mu(x_1) \wedge \nu(x_2)), \quad x, x_1, x_2 \in G.$$

Proposition: 1.2.5

If μ is a fuzzy subgroup of a group, then $\mu(xy) = \min(\mu(x), \mu(y))$ for each $x, y \in G, \mu(x) \neq \mu(y)$.

Proof (see A Mustafa [2])

1.2.6 Properties of fuzzy subgroups

Utilizing the definitions given above we come up with the following properties of fuzzy subgroups.

Proposition: 1.2.6.1

If μ is a fuzzy subset of a group G , then μ is a fuzzy subgroup if and only if each μ_t is a subgroup of $G, 0 \leq t \leq 1$.

Proof

(\Rightarrow) μ is a fuzzy subgroup. We need to show that μ_t is a subgroup of G . Let

$$x, y \in \mu_t \text{ then } \mu(x) \geq t \text{ and } \mu(y) \geq t \Rightarrow \mu(xy) \geq \min(\mu(x), \mu(y)) \geq t \Rightarrow xy \in \mu_t$$

Let $x \in \mu_t$ then $\mu(x) \geq t \Rightarrow \mu(x^{-1}) = \mu(x) \geq t$, thus $x^{-1} \in \mu_t$.

Therefore μ_t is a subgroup of G .

(\Leftarrow) μ_t is a subgroup of $G \ \forall t \in [0,1]$. We need to show that μ is a fuzzy subgroup of G .

Let $x, y \in G$. For $x \in \mu_t$ and $y \in \mu_t$ we have $\mu(x) \geq t$ and $\mu(y) \geq t$.

But since μ_t is a subgroup of G then $xy \in \mu_t \Rightarrow \mu(xy) \geq t$.

Therefore $\mu(xy) \geq \min(\mu(x), \mu(y))$.

Case $x \in \mu_t$ and $y \in \mu_s$.

If $s < t$ then $\mu_t \subseteq \mu_s$, so $x \in \mu_s$. Thus $x, y \in \mu_s$ and since μ_s is a subgroup of G this implies that $xy \in \mu_s \Rightarrow \mu(xy) \geq \min(\mu(x), \mu(y))$. Similarly if $t < s$.

Let $x \in G$. For $x \in \mu_t$ we have $x^{-1} \in \mu_t \Rightarrow \mu(x^{-1}) \geq t \Rightarrow \mu(x^{-1}) \geq \mu(x), \forall x \in G$.

Thus $\mu(x) = \mu((x^{-1})^{-1}) \geq \mu(x^{-1})$. Hence $\mu(x) = \mu(x^{-1})$.

Therefore μ is a subgroup of G . This completes the proof. \square

Proposition: 1.2.6.2

Let μ be a fuzzy subset of G . Then μ is a fuzzy subgroup

of $G \Leftrightarrow \forall a_\lambda, b_\beta \in \mu \Rightarrow a_\lambda(b^{-1})_\beta \in \mu$.

Proof

(\Rightarrow) assume μ is a fuzzy subgroup. Let $a_\lambda, b_\beta \in \mu$. Then $\mu(a) \geq \lambda$ and $\mu(b) \geq \beta$.

Now $\mu(ab^{-1}) \geq \mu(a) \wedge \mu(b^{-1}) = \mu(a) \wedge \mu(b) \geq \lambda \wedge \beta$

$$\Rightarrow (ab^{-1})_{\lambda \wedge \beta} \in \mu \Rightarrow a_\lambda(b^{-1})_\beta \in \mu$$

(\Leftarrow) let $x, y \in G$. We need to show that $\mu(xy) \geq \mu(x) \wedge \mu(y)$. Let $\mu(x) = \lambda$ and $\mu(y) = \beta$. If $\lambda = 0, \beta \neq 0$ then $\mu(xy) \geq 0 = \mu(x) \wedge \mu(y)$. Now we assume $\lambda, \beta \neq 0$.

So $x_\lambda, y_\beta \in \mu \Rightarrow (xy)_{\lambda \wedge \beta} \in \mu, \Rightarrow \mu(xy) \geq \lambda \wedge \beta = \mu(x) \wedge \mu(y)$.

To show that $\mu(x^{-1}) = \mu(x)$ we proceed as follows: case $\mu(x) = \lambda \neq 0$. Let $\mu(x) = \lambda$, then $x_\lambda \in \mu \Rightarrow x_\lambda(x^{-1})_\lambda \in \mu$, thus $(xx^{-1})_\lambda = e_\lambda \in \mu$. Now

$e_\lambda, x_\lambda \in \mu \Rightarrow x_\lambda^{-1} \in \mu \Rightarrow \mu(x^{-1}) \geq \mu(x)$. By symmetry $\mu(x) \geq \mu(x^{-1})$. Therefore μ

is a fuzzy subgroup. \square

Theorem: 1.2.6.3

Let $f : G \rightarrow G$ be a homomorphism of G into G . If μ is a fuzzy subgroup of G , then $f(\mu)$ is a fuzzy subgroup of G .

Proof

We need to show the two conditions of section 1.2. Since f is into therefore

$$f(\mu)(y) = \begin{cases} \sup_{a \in f^{-1}(y)} \mu(a) & \text{if } y \in f(G) \\ 0 & \text{if } y \notin f(G) \end{cases}$$

Suppose $y \in f(G)$, then $y^{-1} \in f(G)$. Thus

$$f(\mu)(y^{-1}) = \sup_{y^{-1}=f(a)} (\mu(a)) = \sup_{y=f(a^{-1})} (\mu(a^{-1})) \leq f(\mu)(y), \forall y \in G.$$

So $f(\mu)(y) = f(\mu)((y^{-1})^{-1}) \leq f(\mu)(y^{-1}) \Rightarrow f(\mu)(y) = f(\mu)(y^{-1})$.

Suppose $y \notin f(G)$, then $y^{-1} \notin f(G) \Rightarrow f(\mu)(y^{-1}) = 0 = f(\mu)(y)$.

Let $y_3 = y_1 y_2$, we aim to show that $f(\mu)(y_1) \wedge f(\mu)(y_2) \leq f(\mu)(y_3)$.

$$\text{Consider } f(\mu)(y_3) = \sup_{y_3=f(a)} (\mu(a)), f(\mu)(y_1) = \sup_{y_1=f(a_1)} (\mu(a_1))$$

and $f(\mu)(y_2) = \sup_{y_2=f(a_2)} (\mu(a_2))$. Taking $\xi > 0$, then

$$f(\mu)(y_1) \wedge f(\mu)(y_2) - \xi < \mu(a_1) \wedge \mu(a_2) \text{ for}$$

some $a, a_1, a_2 : y_1 = f(a_1), y_2 = f(a_2), a = a_1 a_2$ and $y_3 = y_1 y_2$.

Now $y_3 = y_1 y_2 = f(a_1) f(a_2) = f(a_1 a_2) = f(a)$ and $\mu(a_1) \wedge \mu(a_2) \leq \mu(a_1 a_2) = \mu(a)$.

This implies that

$$f(\mu)(y_1) \wedge f(\mu)(y_2) - \xi < \mu(a) \leq \sup_{y_3=f(a)} (\mu(a)) = f(\mu)(y_3)$$

$\Rightarrow f(\mu)(y_1) \wedge f(\mu)(y_2) \leq f(\mu)(y_3)$. Since ξ is arbitrary.

Thus $f(\mu)$ is a fuzzy subgroup of G . □

Proposition: 1.2.6.4

Let $f : G \rightarrow G$ be a homomorphism and μ a fuzzy subgroup of a group G . Then

$f^{-1}(\mu)$ is a fuzzy subgroup of G .

Proof

$$f^{-1}(\mu)(a^{-1}) = \mu(f(a^{-1}))$$

$$\begin{aligned}
&= \mu(f(a)^{-1}) \\
&= \mu(f(a)) \\
&= f^{-1}(\mu)(a)
\end{aligned}$$

$$\begin{aligned}
\text{Finally } f^{-1}(ab) &= \mu(f(ab)) = \mu(f(a)f(b)) \\
&\geq \mu(f(a)) \wedge \mu(f(b)) \\
&= f^{-1}(\mu)(a) \wedge f^{-1}(\mu)(b)
\end{aligned}$$

Therefore $f^{-1}(\mu)(ab) \geq f^{-1}(\mu)(a) \wedge f^{-1}(\mu)(b)$. □

1.3 Fuzzy Normal subgroups

Definition: 1.3.1 [20]

If μ is a fuzzy subgroup of a group G , then μ is called a fuzzy normal subgroup if

$$\mu(xy) = \mu(yx), \forall x, y \in G.$$

Equivalently μ is fuzzy normal if and only if $\mu(xyx^{-1}) = \mu(y), \forall x, y \in G$

Proof

(\Rightarrow) Suppose μ is fuzzy normal, then $\mu(xy) = \mu(yx), \forall x, y \in G$

$$\begin{aligned}
\Rightarrow \mu(xyx^{-1}) &= \mu(x(yx^{-1})) = \mu(yx^{-1}x) \\
&= \mu(y), \forall x, y \in G.
\end{aligned}$$

(\Leftarrow) Suppose $\mu(xyx^{-1}) = \mu(y), \forall x, y \in G$

Then $\mu(xy) = \mu(xyxx^{-1}) = \mu(yx)$ □

Proposition: 1.3.2

If μ, ν are fuzzy subgroups of a group G and μ is fuzzy normal, then $\mu\nu$ is a fuzzy subgroup of G .

Proof

We need to show the two conditions of definition 1.2. To show that

$$\mu\nu(xy) \geq \mu\nu(x) \wedge \mu\nu(y) \quad \text{we let } \mu\nu(x) = \sup_{x=x_1x_2} (\mu(x_1) \wedge \nu(x_2))$$

and $\mu\nu(y) = \sup_{y=y_1y_2} (\mu(y_1) \wedge \nu(y_2))$. Let $\xi > 0, \exists x_1, x_2, y_1, y_2 : x = x_1x_2, y = y_1y_2$ and

$\mu\nu(x) - \frac{\xi}{2} < \mu(x_1) \wedge \nu(x_2)$ and $\mu\nu(y) - \frac{\xi}{2} < \mu(y_1) \wedge \nu(y_2)$. Then

$$(\mu\nu(x) \wedge \mu\nu(y)) - \frac{\xi}{2} = \left(\mu\nu(x) - \frac{\xi}{2} \right) \wedge \left(\mu\nu(y) - \frac{\xi}{2} \right) < \mu(x_1) \wedge \nu(x_2) \wedge \mu(y_1) \wedge \nu(y_2)$$

$$\begin{aligned} &= \mu(x_1) \wedge \mu(x_2y_1x_2^{-1}) \wedge \nu(x_2) \wedge \nu(y_2) \\ &\leq \mu(x_1(x_2y_1x_2^{-1})) \wedge \nu(x_2y_2) \leq \mu\nu(xy) \end{aligned}$$

(by normality of μ) and since $xy = x_1x_2y_1x_2^{-1}x_2y_2$

Therefore $\mu\nu(x) \wedge \mu\nu(y) \leq \mu\nu(xy)$ since ξ is arbitrary.

Condition (b): Let $x \in G$ then $\mu\nu(x^{-1}) = \sup_{x^{-1}=x_1x_2} ((\mu(x_1) \wedge \nu(x_2)))$

$$= \sup_{x=x_2^{-1}x_1^{-1}} (\mu(x_1^{-1}) \wedge \nu(x_2^{-1})) \text{ since } \mu \text{ and}$$

ν are fuzzy subgroups

$$= \sup_{x=x_2^{-1}x_1^{-1}} (\mu(x_2^{-1}x_1^{-1}x_2) \wedge \nu(x_2^{-1})) \text{ (by}$$

normality of μ)

$$\leq \mu\nu(x_2^{-1}x_1^{-1}) = \mu\nu(x) \text{ since}$$

$$x_2^{-1}x_1^{-1}x_2x_2^{-1} = x_2^{-1}x_1^{-1} = x.$$

By symmetry we also have $\mu\nu(x^{-1}) \geq \mu\nu(x)$

Therefore equality holds. □

Proposition: 1.3.3

If μ and ν are both fuzzy normal subgroups of G , then $\mu\nu$ is a fuzzy normal subgroup of G .

Proof

We need to show that $\mu\nu(xyx^{-1}) = \mu\nu(y), \forall x, y \in G$.

$$\begin{aligned} \mu\nu(xyx^{-1}) &= \sup_{xyx^{-1}=ab} (\mu(a) \wedge \mu(b)) \\ &= \sup (\mu(x^{-1}ax) \wedge \nu(x^{-1}bx)) \text{ (by normality of } \mu \text{ and } \nu) \\ &\leq \mu\nu(y) \text{ since } y = x^{-1}abx = x^{-1}axx^{-1}bx \end{aligned}$$

Thus $\mu\nu(y) \geq \mu\nu(x^{-1}yx), \forall x, y \in G$.

$$\Rightarrow \mu\nu(y) = \mu\nu(x^{-1}yx)$$

$$\leq \mu\nu(xyx^{-1})$$

Therefore $\mu\nu(y) = \mu\nu(xyx^{-1}) \Rightarrow \mu\nu$ is a fuzzy normal subgroup of G . \square

Proposition: 1.3.4

If μ and ν are fuzzy subgroups of G and μ is fuzzy normal, then $\mu\nu = \nu\mu$.

Proof

$$\begin{aligned} \nu\mu(x) &= \sup_{x=x_1x_2} (\nu(x_1) \wedge \mu(x_2)) \\ &= \sup_{x=x_1x_2} (\mu(x_1x_2x_1^{-1}) \wedge \nu(x_1)) \text{ since } \mu \text{ is fuzzy normal.} \\ &\leq \mu\nu(x_1x_2) = \mu\nu(x) \text{ since } x = x_1x_2x_1^{-1}x_1. \end{aligned}$$

Similarly $\mu\nu(x) \leq \nu\mu(x)$. \square

Proposition: 1.3.5

Let μ be a fuzzy subgroup of G . μ is fuzzy normal if and only if each μ_t is a normal fuzzy subgroup of G , $\forall t \in [0,1]$.

Proof

(\Rightarrow)

We need to show that $x\mu_t x^{-1} = \mu_t, \forall x \in G$

Let $h \in \mu_t$ then $\mu(h) \geq t$

$$\Rightarrow \mu(h) = \mu(xhx^{-1}) \geq t$$

$$\Rightarrow xhx^{-1} \in \mu_t, \forall x \in G, h \in \mu_t.$$

$$\Rightarrow \mu_t \subseteq x^{-1}\mu_t x. \text{ Therefore } \mu_t \subseteq x\mu_t x^{-1}$$

Let $y \in x\mu_t x^{-1}$. Now $y = xhx^{-1}$ for some $h \in \mu_t$. Then $\mu(y) = \mu(xhx^{-1}) = \mu(h) \geq t$, since μ is normal. This implies that $\mu(y) \geq t \Rightarrow y \in \mu_t$. Therefore $x\mu_t x^{-1} \subseteq \mu_t$.

Thus $x\mu_t x^{-1} = \mu_t$.

(\Leftarrow) Let $x, y \in G$, also set $\mu(x) = t$. Then $x \in \mu_t = y\mu_t y^{-1}$ since μ_t normal.

Therefore $y^{-1}xy \in \mu_t \Rightarrow \mu(y^{-1}xy) \geq t = \mu(x)$, $\forall x, y \in G$. This implies that

$$\mu(x) = \mu(y^{-1}(yxy^{-1})y) \geq \mu(yxy^{-1}).$$

Therefore $\mu(x) = \mu(yxy^{-1}), \forall x, y \in G$. Thus μ is a fuzzy normal subgroup of G . \square

Chapter Two

FUZZY EQUIVALENCE RELATION AND FUZZY ISOMORPHISM

2.0 Introduction

Relating objects that are perceived equal requires the notion of equivalence relations. Studies on the implications of this equivalence relation on fuzzy subsets of a set were accomplished by a number of authors, for example in [24] Murali defined and studied properties, including cuts, of fuzzy equivalence relations on a set. In this chapter we first give a definition of an equivalence relation in general and secondly that of a fuzzy equivalence relation (for more see Murali [24], Murali and Makamba [25], [26] and [27], Ngcibi [30]). We study the natural equivalence relation introduced by Murali and Makamba (for more details see [25], [26] and [27]) and show that it is indeed an equivalence relation. We study the equivalence of fuzzy subsets of a set as a foundation to the study of equivalence of fuzzy subgroups of a group G . This we accomplish by assigning equivalence classes to the fuzzy subgroups of that group. The definition of an equivalence class of an element of a set is given in 2.3.2. Some consequences of equivalence of fuzzy subgroups are given. We also define a t -norm, characterize a t -norm that is continuous and briefly discuss the usefulness of t -norms.

2.1 An Equivalence Relation

Definition: 2.1.0

A relation \mathfrak{R} , on X is a subset D of $X \times X$ and we write $x\mathfrak{R}y \Leftrightarrow (x, y) \in D$.

Now \mathfrak{R} is an equivalence relation on X if $\forall x, y, z \in X$:

- (a) $x\mathfrak{R}x, \forall x \in X$ (Reflexive law)
- (b) $x\mathfrak{R}y \Rightarrow y\mathfrak{R}x$ (Symmetric law)
- (c) $x\mathfrak{R}y$ and $y\mathfrak{R}z \Rightarrow x\mathfrak{R}z$ (Transitive law)

2.2 Fuzzy Relations

Definition: 2.2.1

A fuzzy relation μ between elements of two sets X and Y is a fuzzy subset of $X \times Y$ given by $\mu : X \times Y \rightarrow I, (x, y) \rightarrow \mu(x, y)$.

Note: $\mu(x, y)$ is thought as the degree to which x is related to y . The μ defined above is a binary relation and is said to be:

- (a) Reflexive if $\mu(x, x) = 1, \forall x \in X$
- (b) Symmetric if $\mu(x, y) = \mu(y, x), \forall x, y \in X$
- (c) Transitive if $\mu \circ \mu \leq \mu$ where $\mu \circ \mu$ is defined by

$$\mu \circ \mu(x, y) = \sup_{z \in X} (\mu(x, z) \wedge \mu(z, y)).$$

Any fuzzy relation that satisfies (a), (b) and (c) is called a fuzzy equivalence relation on X .

2.3 Fuzzy Equivalence relation

We define an equivalence relation on I^X as follows:

Definition: 2.3.1 [25]

Let μ and ν be two fuzzy subgroups. μ is fuzzy equivalent to ν denoted by $\mu \approx \nu$ if and only if $\mu(x) > \mu(y) \Leftrightarrow \nu(x) > \nu(y)$ and $\mu(x) = 0 \Leftrightarrow \nu(x) = 0$.

Claim : Definition 2.3.1 is an equivalence relation.

We have to check (1) Reflexive law: (Clear from definition)

(2) Symmetric law : Need to show that $\mu \approx \nu \Rightarrow \nu \approx \mu$

Now $\mu \approx \nu \Leftrightarrow \mu(x) > \mu(y) \Leftrightarrow \nu(x) > \nu(y)$ and $\mu(x) = 0 \Leftrightarrow \nu(x) = 0$ 2.3.1.a

Interchanging the roles of μ and ν in 2.3.1.a we obtain:

$$\mu \approx \nu.$$

(3) Transitive law: Need to show that for $\mu, \nu, \beta \in I^G$, $\mu \approx \nu$ and $\nu \approx \beta \Rightarrow \mu \approx \beta$.

Now using 2.3.1.a and the fact that $\nu \approx \beta \Leftrightarrow \nu(x) > \nu(y) \Leftrightarrow \beta(x) > \beta(y)$ and

$\nu(x) = 0 \Leftrightarrow \beta(x) = 0$ we obtain $\mu(x) > \mu(y) \Leftrightarrow \beta(x) > \beta(y)$ and

$\mu(x) = 0 \Leftrightarrow \beta(x) = 0 \Leftrightarrow \mu \approx \beta$ therefore 2.3.1 defines an equivalence relation on G .

Definition: 2.3.2

Let A be a set and \mathfrak{R} an equivalent relation on A , then the equivalence class of $a \in A$ is a set $\{x \in A : a\mathfrak{R}x\}$.

Proposition: 2.3.3

Let G be a finite group and μ be a fuzzy subgroup of G . If t_i, t_j are elements of the image set of μ such that $\mu_{t_i} = \mu_{t_j}$, then $t_i = t_j$.

Proof[6]

Proposition: 2.3.4

$\mu \approx \nu \Rightarrow \text{Im } \mu = \text{Im } \nu$

Proof[20]

Definition: 2.3.5

Let $T : [0,1]^2 \rightarrow [0,1]$ be a binary operation, then T is called a triangular norm

(t -norm) if (a) T is associative

(b) T is commutative

(c) T is non-decreasing for both variables

(d) $T(x,1) = x, \forall x \in [0,1]$

2.3.6 Consequences of definition 2.3.5.

***A t -norm T is called count if it preserves the least upper bound.

***A t -norm T is called Archimedean if $T(x,x) < x$ for any $x \in [0,1]$.

2.3.7 Characterization of an equivalence by a t -norm T that is continuous.

An equivalence can be defined as follows:

$$x \leftrightarrow_T y = T((x \rightarrow_T y), (y \rightarrow_T x)).$$

This is so because the implication is defined by:

$$x \rightarrow_T y = \max\{z \mid T(x, z) \leq y\}.$$

Similarly

$$y \rightarrow_T x = \max\{z \mid T(y, z) \leq x\}$$

2.3.8 Usefulness of t -norms

Although the min, union, product and bounded sum operators belong to a class of t -norms, there are unique definitions for the intersection (=and) and union (=or) in dual logic, traditional set theory and fuzzy set theory. This is so because most operators only behave exactly the same if the degrees of membership are restricted to the values 0 and 1. This shows that there are other ways of aggregating fuzzy sets besides the min and union.

A t -norm T as given in Definition 2.3.5 defines an intersection and union of two fuzzy sets μ_A and μ_B as follows :

$$(i) \text{ Intersection } T[\mu_A(x), \mu_B(x)] = \mu_{A \cap B}(x), \forall x \in G.$$

$$(ii) \text{ Union } T[\mu_A(x), \mu_B(x)] = \mu_{A \cup B}(x), \forall x \in G.$$

So using this definition we note that (b) and (c) ensure that a decrease of the degree of membership to set A or set B will not involve an increase to the degree of membership to the intersection. Symmetry is also expressed by (b), and (a) guarantees that the intersection of any number of fuzzy sets can be performed in any order.

Apart from the already mentioned use, a t -norm can be used to define a notion of isomorphism.

2.4 Fuzzy Isomorphism

Researchers, amongst them Makamba [20] and Murali and Makamba [25], studied the number of distinct fuzzy subgroups of a group using an equivalence relation and compared with the notion of isomorphism. They noticed that the notion of fuzzy equivalence is finer than the notion of fuzzy isomorphism. We therefore define fuzzy isomorphism as a generalization of the equivalence relation presented in section 2.3. This will enable us to establish a technique to calculate the number of isomorphic classes of fuzzy subgroups of finite groups we are to study in chapter three. We start with defining a homomorphism for the sake of completeness.

Definition: 2.4.1 Let $(G, *)$ and (G', \circ) be groups. A mapping $f : G \rightarrow G'$ such that $f(a * b) = f(a) \circ f(b), \forall a, b \in G$ is called a homomorphism.

Definition: 2.4.2

A homomorphism that is also a 1–1 correspondence is called an isomorphism. Such a mapping is said to preserve the group operation.

We will denote two groups G and G' that are isomorphic by $G \approx G'$.

Theorem: 2.4.3

Isomorphism is an equivalence relation on the class of all groups.

Proof[30]

Definition: 2.4.4

Let μ and ν be two fuzzy subgroups of groups G and G' respectively. Then we say μ is fuzzy isomorphic to ν , denoted $\mu \cong \nu \Leftrightarrow \exists$ an isomorphism $f : G \rightarrow G'$ such that $\mu(x) > \mu(y) \Leftrightarrow \nu(f(x)) > \nu(f(y))$ and $\mu(x) = 0 \Leftrightarrow \nu(f(x)) = 0$.

2.4.5 Homomorphism and Equivalence

Equivalence classes of homomorphic images and pre-images of fuzzy subgroups were investigated by Murali and Makamba in [27], they discovered that subgroup property is transferred to images and pre-images by a homomorphism between groups. They also noted that inequivalent fuzzy subgroups may have equivalent images under a homomorphism.

We recall that if $f : G \rightarrow G'$ is a homomorphism, by $f(\mu)$ we mean the image of a fuzzy subset μ of G and is a fuzzy subset of G' defined by

$(f(\mu))(g') = \sup\{\mu(g) : g \in G, f(g) = g'\}$ if $f^{-1}(g') \neq \emptyset$ and $(f(\mu))(g') = 0$ if $f^{-1}(g') = \emptyset$ for $g' \in G'$. Similarly if ν is a fuzzy subset of G' , the pre-image of ν , $f^{-1}(\nu)$ is a fuzzy subset of G and is defined by $(f^{-1}(\nu))(g) = \nu(f(g))$.

In propositions 2.4.6 and 2.4.7 we suppose that $f : G \rightarrow H$ is a homomorphism from a group G to H .

Although a proof of Proposition 2.4.6 is given by Murali and Makamba in [27] we give a different proof using the definition $f(\mu)(x) = \sup_{x=f(a)} \mu(a)$.

Proposition: 2.4.6 [27]

If $\mu \approx \nu$ then $f(\mu) \approx f(\nu)$.

Proof

Let $f(\mu)(f(a)) > f(\mu)(f(b))$. We need to show that $f(\nu)(f(a)) > f(\nu)(f(b))$. Now since f is an isomorphism, then $f(x_1) = f(a) \Leftrightarrow x_1 = a$ and $f(x_2) = f(b) \Leftrightarrow x_2 = b$.

So $f(\mu)(f(a)) > f(\mu)(f(b)) \Rightarrow \sup_{f(x_1)=f(a)} \mu(x_1) > \sup_{f(x_2)=f(b)} \mu(x_2)$ therefore $\mu(a) > \mu(b)$.

But $\mu \approx \nu \Rightarrow \nu(a) > \nu(b)$.

Therefore $\sup_{f(a)=f(x_1)} \nu(x_1) > \sup_{f(b)=f(x_2)} \nu(x_2)$ that is $f(\nu)(f(a)) > f(\nu)(f(b))$ and conversely.

If $f(\mu)(f(x)) = 0$ then $\sup_{f(a)=f(x)} \mu(a) = 0 = \mu(x)$ this implies that $\nu(x) = 0$ since

$\mu \approx \nu$. This implies that $\sup_{f(a)=f(x)} \nu(a) = 0 \Rightarrow f(\nu)(f(x)) = 0$ Thus $f(\mu) \approx f(\nu)$ and

conversely. □

Proposition: 2.4.7[27]

If $\mu \approx \nu$ in H then $f^{-1}(\mu) \approx f^{-1}(\nu)$ in G .

Proof. Straightforward.

Chapter Three

ON EQUIVALENCE OF FUZZY SUBGROUPS AND ISOMORPHIC CLASSES OF FUZZY SUBGROUPS OF SELECTED FINITE GROUPS

3.0 Introduction

Characterization of finite groups has been studied by a number of researchers, for example Fraleigh [13] and Baumslag and Chandler [4]. Murali and Makamba [25], [26] and [27] looked into equivalence of fuzzy subgroups in order to characterize fuzzy subgroups of finite abelian groups. Ngcibi [30] also employed the equivalence relation used by Murali and Makamba to determine the number of distinct fuzzy subgroups of some specific p-groups. In this chapter we use this equivalence to study the characterization of the following groups: the symmetric group S_3 , dihedral group D_4 , the quaternion group Q_8 , cyclic p-group $G = Z_{p^n}$ and the group $G = Z_{p^n} \times Z_{q^m}$. We begin by presenting their subgroups, lattices of subgroups and maximal chains. We also use the definition of isomorphism given in chapter two to determine the number of equivalence and isomorphic classes of fuzzy subgroups of these groups. We then compare the number of equivalence and isomorphic classes for the groups.

3.1 Equivalent Fuzzy Subgroups

Definition: 3.1.1

Two fuzzy subgroups μ and ν are said to *distinct* if and only if $[\mu] \neq [\nu]$, where $[\mu]$ and $[\nu]$ are equivalence classes containing μ and ν respectively.

3.1.2 Examples of equivalent and non-equivalent fuzzy subgroups

Example: 3.1.2.1

Let $S_3 = \{e, a, a^2, b, ab, a^2b\}$ where $a^3 = e = b^2$ and e is the identity element. Define

$$\text{fuzzy sets } \mu(x) = \begin{cases} 1 & \text{if } x = e \\ \frac{1}{4} & \text{if } x = a, a^2 \\ \frac{1}{7} & \text{if otherwise} \end{cases} \text{ and } \nu(x) = \begin{cases} 1 & \text{if } x = e \\ \frac{1}{4} & \text{if } x = b \\ \frac{1}{7} & \text{if otherwise} \end{cases}$$

Here $\text{supp } \mu = \text{supp } \nu = S_3$ and $\mu(a) > \mu(b)$ but $\nu(a) \not> \nu(b)$ therefore $\mu \neq \nu$.

Example: 3.1.2.2

Let $S_3 = \{e, a, a^2, b, ab, a^2b\}$ where $a^3 = e = b^2$ and e is the identity element. Define

$$\text{fuzzy sets } \mu(x) = \begin{cases} 1 & \text{if } x = e \\ \frac{1}{2} & \text{if } x = ab \\ \frac{1}{3} & \text{if otherwise} \end{cases}$$

$$\text{and } \nu(x) = \begin{cases} 1 & \text{if } x = e \\ \frac{1}{2} & \text{if } x = ab \\ 0 & \text{if otherwise} \end{cases}$$

Clearly $\mu(ab) > \mu(a)$ iff $\nu(ab) > \nu(a)$ but $\text{supp } \mu \neq \text{supp } \nu$ therefore μ is not equivalent to ν .

3.2 Classification of Fuzzy Subgroups of Finite Groups

The examples given above demonstrate the importance of all the conditions in definition 2.3.1. In order to enumerate the number of distinct fuzzy subgroups and isomorphic classes of specific groups in the sections to follow, we begin by explaining how in general, distinct fuzzy subgroups can be identified from a fixed maximal chain of subgroups. The chain is said to be maximal if it cannot be refined. The definitions of a keychain, pin and pinned-flag are given in section 5.1.0. Now given any maximal chain of subgroups

$$\{0\} \subseteq G_1 \subseteq G_2 \subseteq \dots \subseteq G_{n-1} \subseteq G_n \dots 3.2a,$$

we say that the maximal chain has length $(n+1)$, which is the number of components in the maximal chain. A fuzzy subgroup μ can be represented by the following ordered symbols $1\lambda_1\lambda_2\dots\lambda_{n-1}\lambda_n$ where the λ_i 's are real numbers in $[0,1]$ that are in descending order. The λ_i 's are called pins. We observe that there are $(n+1)$ pins for this maximal chain. If we identify each G_i with λ_i , we have the fuzzy subgroup

$$\mu(x) = \begin{cases} 1 & \text{if } x = 0 \\ \lambda_1 & \text{if } x \in G_1 \setminus \{0\} \\ \lambda_2 & \text{if } x \in G_2 \setminus G_1 \\ \cdot & \cdot & \cdot \\ \cdot & \cdot & \cdot \\ \cdot & \cdot & \cdot \\ \lambda_n & \text{if } x \in G_n \setminus G_{n-1} \end{cases}$$

$1\lambda_1\lambda_2\dots\lambda_{n-1}\lambda_n$ is called a keychain of μ . We sometimes write $\mu = 1\lambda_1\lambda_2\dots\lambda_{n-1}\lambda_n$, thus we identify μ with its keychain when the underlying maximal chain of subgroups is known. Each G_i is a component of the maximal chain.

Example: 3.2.0

(a) The maximal chain $\{0\} \subset Z_p$ has two components (levels). We therefore have the following distinct fuzzy subgroups for this chain: 11 , 1λ and 10 .

(b) The maximal chain $\{e\} \subset B_0 \subset S_3$ has three components (levels).

Corresponding to this maximal chain there are seven distinct fuzzy subgroups represented by the keychains $111, 11\lambda, 110, 1\lambda\lambda, 1\lambda\beta, 1\lambda 0, 100$.

3.2.1 Fuzzy Subgroups of the symmetric group S_3

The group of symmetries of three objects has order 6 and is defined as

$$S_3 = \{e, a, a^2, b, ab, a^2b\} \text{ where } a^3 = e = b^2.$$

Its subgroups are $B_0 = \{e, a, a^2\}$, $B_1 = \{e, b\}$, $B_2 = \{e, ab\}$, $B_3 = \{e, a^2b\}$, $\{e\}$ and S_3 .

It has four maximal chains viz

$$\{e\} \subset B_0 \subset S_3, \{e\} \subset B_1 \subset S_3, \{e\} \subset B_2 \subset S_3 \text{ and } \{e\} \subset B_3 \subset S_3 \quad 3.2.1a$$

From equation 3.2.1a each chain is of length three, which means that we can represent each fuzzy subgroup using a keychain^{**} with three pins^{***}, for example $\mu = 1\lambda\beta$ where $1 > \lambda > \beta \neq 0$ on the first chain.

$$\text{Thus } \mu(x) = \begin{cases} 1 & \text{if } x = e \\ \lambda & \text{if } x \in B_0 \setminus \{e\} \\ \beta & \text{if } x \in S_3 \setminus B_0 \end{cases} \quad 3.2.1b$$

$$\text{If } \nu(x) = \begin{cases} 1 & \text{if } x = e \\ \lambda_1 & \text{if } x \in B_0 \setminus \{e\} \\ \beta_1 & \text{if } x \in S_3 \setminus B_0 \end{cases} \text{ for } 1 > \lambda_1 > \beta_1 \neq 0 \text{ then } \mu \approx \nu, \text{ thus } \mu = 1\lambda\beta \text{ is}$$

actually a class of fuzzy subgroups.

*The definitions of a keychain^{**} and pin^{***} are given in section 5.1.0. and 5.1.1 respectively.*

Now in computing the number of distinct equivalence classes of fuzzy subgroups for the entire group, we consider all the maximal chains as follows:

$$\text{Let: } \mu = 1\lambda\beta \text{ on the first chain, that is } \mu(x) = \begin{cases} 1 & \text{if } x = e \\ \lambda & \text{if } x \in B_0 \setminus \{e\} \\ \beta & \text{if } x \in S_3 \setminus B_0 \end{cases}$$

$$\nu = 1\lambda\beta \text{ on the second chain, that is } \nu(x) = \begin{cases} 1 & \text{if } x = e \\ \lambda & \text{if } x \in B_1 \setminus \{e\} \\ \beta & \text{if } x \in S_3 \setminus B_1 \end{cases}$$

$$\xi = 1\lambda\beta \text{ on the third chain, that is } \xi(x) = \begin{cases} 1 & \text{if } x = e \\ \lambda & \text{if } x \in B_2 \setminus \{e\} \\ \beta & \text{if } x \in S_3 \setminus B_2 \end{cases}$$

$$\tau = 1\lambda\beta \text{ on the fourth chain, that is } \tau(x) = \begin{cases} 1 & \text{if } x = e \\ \lambda & \text{if } x \in B_3 \setminus \{e\} \\ \beta & \text{if } x \in S_3 \setminus B_3 \end{cases}$$

From the above discussion we are able to identify that μ, ν, ξ and τ are distinct fuzzy subgroups when considering these four distinct chains.

If the number of distinct equivalence classes of fuzzy subgroups is computed for each maximal chain, then the total number of equivalence classes of fuzzy subgroups for the group can be calculated. The following section demonstrates how this fact is used to calculate the number of equivalence classes of fuzzy subgroups of S_3 .

3.2.2 Technique for calculating the number of equivalence classes of fuzzy subgroups of S_3 :

Consider the chain $\{e\} \subset B_0 \subset S_3$ in 3.2.1a. The number of distinct classes of fuzzy subgroups was found to be equal to seven viz $111 \ 11\lambda \ 110 \ 1\lambda\lambda \ 1\lambda\beta \ 1\lambda 0 \ 100$. Each one of the keychains above is used for each maximal chain in the enumeration of the total number of fuzzy subgroups of the whole group. These results are tabulated in the table below.

Distinct Keychains	# of ways each counts if all chains considered
111	1
11 λ	4
110	4
1 $\lambda\lambda$	1
1 $\lambda\beta$	4
1 $\lambda 0$	4
100	1
Total # of distinct equivalence classes of fuzzy subgroups	19

Thus the number of distinct equivalence classes of fuzzy subgroups for the group $G = S_3$ is 19.

Now looking at the table above, the class of fuzzy subgroup represented by the keychain 111 has a count one because if we consider each chain, this keychain represents the same fuzzy subgroup $\mu(x) = 1, \forall x \in S_3$ in all the chains of subgroups.

The fuzzy subgroup 11λ counts four times because for the same λ in all the four chains $x \in B_0 \setminus e$ or $x \in B_1 \setminus e$ or $x \in B_2 \setminus e$ or $x \in B_3 \setminus e$ which are different sets.

What this means is that the same keychain 11λ represents a different class of equivalent fuzzy subgroups on different maximal chains of subgroups.

From the construction of fuzzy subgroups in section 3.2.1 with $1\lambda\beta$ replaced with 11λ we have:

$$\mu(a) = \mu(a^2) > \mu(b) = \mu(ab) = \mu(a^2b)$$

$$\nu(b) > \nu(a) = \nu(a^2) = \nu(ab) = \nu(a^2b)$$

$$\xi(ab) > \xi(a) = \xi(a^2) = \xi(b) = \xi(a^2b)$$

$$\tau(a^2b) > \tau(a) = \tau(a^2) = \tau(b) = \tau(ab)$$

From the argument above it is clear that μ, ν, ξ and τ are distinct equivalence classes of fuzzy subgroups under the equivalence we are executing, hence the count of four. Similarly the keychains 110, $1\lambda\beta$ and $1\lambda 0$ will give a count of four.

3.2.3 The Dihedral group D_4

The group of symmetries of a square or the octic, has order eight.

To identify the subgroups of this group we consider the number of permutations corresponding to the ways that two copies of a square with vertices 1, 2, 3 and 4 can be placed, one covering the other. If we basically use ρ_i for rotations, μ_i for mirror images in perpendicular bisectors of sides, and δ_i for diagonal flips we obtain the following permutations

$$\rho_0 = \begin{pmatrix} 1 & 2 & 3 & 4 \\ 1 & 2 & 3 & 4 \end{pmatrix} \quad \rho_1 = \begin{pmatrix} 1 & 2 & 3 & 4 \\ 2 & 3 & 4 & 1 \end{pmatrix} \quad \rho_2 = \begin{pmatrix} 1 & 2 & 3 & 4 \\ 3 & 4 & 1 & 2 \end{pmatrix} \quad \rho_3 = \begin{pmatrix} 1 & 2 & 3 & 4 \\ 4 & 1 & 2 & 3 \end{pmatrix}$$

$$\mu_1 = \begin{pmatrix} 1 & 2 & 3 & 4 \\ 2 & 1 & 4 & 3 \end{pmatrix} \quad \mu_2 = \begin{pmatrix} 1 & 2 & 3 & 4 \\ 4 & 3 & 2 & 1 \end{pmatrix} \quad \delta_1 = \begin{pmatrix} 1 & 2 & 3 & 4 \\ 3 & 2 & 1 & 4 \end{pmatrix} \quad \delta_2 = \begin{pmatrix} 1 & 2 & 3 & 4 \\ 1 & 4 & 3 & 2 \end{pmatrix}$$

Alternatively it can be thought of as a group generated by two elements s and r such that $r^4 = 1$, $s^2 = 1$ and $sr = r^{-1}s$. Thus $D_4 = \{1, r, r^2, r^3, s, rs, r^2s, r^3s\}$

3.2.4 Subgroups of D_4

The ten subgroups of D_4 are listed below:

$$\{\rho_0\}, \{\rho_0, \delta_1\}, \{\rho_0, \delta_2\}, \{\rho_0, \rho_2\}, \{\rho_0, \mu_1\}, \{\rho_0, \mu_2\}, \{\rho_0, \rho_1, \rho_2, \rho_3\}, \{\rho_0, \rho_2, \mu_1, \mu_2\}, \{\rho_0, \rho_2, \delta_1, \delta_2\}$$

and D_4 .

In view of the discussion given on subgroups of the octic we are able to construct maximal chains for this group in section 3.2.5.

3.2.5 Maximal Chains for D_4

There are seven maximal chains for this group.

$$\{\rho_0\} \subset \{\rho_0, \delta_2\} \subset \{\rho_0, \rho_2, \delta_1, \delta_2\} \subset D_4$$

$$\{\rho_0\} \subset \{\rho_0, \delta_1\} \subset \{\rho_0, \rho_2, \delta_1, \delta_2\} \subset D_4$$

$$\{\rho_0\} \subset \{\rho_0, \rho_2\} \subset \{\rho_0, \rho_2, \delta_1, \delta_2\} \subset D_4$$

$$\{\rho_0\} \subset \{\rho_0, \rho_2\} \subset \{\rho_0, \rho_1, \rho_2, \rho_3\} \subset D_4$$

$$\{\rho_0\} \subset \{\rho_0, \rho_2\} \subset \{\rho_0, \rho_2, \mu_1, \mu_2\} \subset D_4$$

$$\{\rho_0\} \subset \{\rho_0, \mu_2\} \subset \{\rho_0, \rho_2, \mu_1, \mu_2\} \subset D_4$$

$$\{\rho_0\} \subset \{\rho_0, \mu_1\} \subset \{\rho_0, \rho_2, \mu_1, \mu_2\} \subset D_4$$

3.3.5a

Each chain in 3.3.5a is of length four. A keychain of D_4 is of the form $1\lambda\beta\alpha$ where $1 \geq \lambda \geq \beta \geq \alpha$.

3.2.6 The number of equivalence classes of fuzzy subgroups for D_4 .

In all the chains the distinct fuzzy subgroup 1111 counts once, that is it represents only one fuzzy subgroup $\mu(x) = 1, \forall x \in D_4$. The following table below lists a keychain and the number of distinct fuzzy subgroups it represents.

Distinct Keychains	Number of counts in all chains
1111	1
111 λ	3
1110	3
11 $\lambda\lambda$	5
11 $\lambda\beta$	7
11 λ 0	7

1100	5
1 $\lambda\lambda\lambda$	1
1 $\lambda\lambda\beta$	3
1 $\lambda\lambda 0$	3
1 $\lambda\beta\beta$	5
1 $\lambda\beta\alpha$	7
1 $\lambda\beta 0$	7
1 $\lambda 00$	5
1000	1
Total Number	63

We obtain the above number of equivalence classes of fuzzy subgroups for each keychain as follows :

Using the maximal chains in 3.3.5a consider the keychain 11 $\lambda\beta$

$\mu = 11\lambda\beta$ on the first chain gives

$$\mu(\delta_2) > \mu(\rho_2) = \mu(\delta_1) > \mu(\rho_1) = \mu(\rho_3) = \mu(\mu_1) = \mu(\mu_2)$$

$\nu = 11\lambda\beta$ on the second chain gives

$$\nu(\delta_1) > \nu(\rho_2) = \nu(\delta_2) > \nu(\rho_1) = \nu(\rho_3) = \nu(\mu_1) = \nu(\mu_2)$$

$\xi = 11\lambda\beta$ on the third chain gives

$$\xi(\rho_2) > \xi(\delta_1) = \xi(\delta_2) > \xi(\rho_1) = \xi(\rho_3) = \xi(\mu_1) = \xi(\mu_2)$$

$\psi = 11\lambda\beta$ on the fourth chain gives

$$\psi(\rho_2) > \psi(\rho_1) = \psi(\rho_3) > \psi(\mu_1) = \psi(\mu_2) = \psi(\delta_1) = \psi(\delta_2)$$

$\varpi = 11\lambda\beta$ on the fifth chain gives

$$\varpi(\rho_2) > \varpi(\mu_1) = \xi(\mu_2) > \varpi(\rho_3) = \varpi(\rho_1) = \varpi(\delta_1) = \varpi(\delta_2)$$

$\tau = 11\lambda\beta$ on the sixth chain gives

$$\tau(\mu_2) > \tau(\mu_1) = \tau(\rho_2) > \tau(\rho_3) = \tau(\rho_1) = \tau(\delta_1) = \tau(\delta_2)$$

$\zeta = 11\lambda\beta$ on the seventh chain gives

$$\zeta(\mu_1) > \zeta(\rho_2) = \zeta(\mu_2) > \zeta(\rho_1) = \zeta(\rho_3) = \zeta(\delta_1) = \zeta(\delta_2)$$

From the preceding discussion it is clear that μ , ν , ξ , ψ , ϖ , τ and ζ represent different equivalence classes of fuzzy subgroups when considering all the seven maximal chains hence the count of seven.

Now in the above construction if we replace the keychain $11\lambda\beta$ with $1\lambda\beta\beta$ we have

$\mu = 1\lambda\beta\beta$ on the first chain gives

$$\mu(\delta_2) > \mu(\rho_2) = \mu(\delta_1) = \mu(\rho_1) = \mu(\rho_3) = \mu(\mu_1) = \mu(\mu_2)$$

$\nu = 1\lambda\beta\beta$ on the second chain gives

$$\nu(\delta_1) > \nu(\rho_2) = \nu(\delta_2) = \nu(\rho_1) = \nu(\rho_3) = \nu(\mu_1) = \nu(\mu_2)$$

$\xi = 1\lambda\beta\beta$ on the third chain gives

$$\xi(\rho_2) > \xi(\delta_1) = \xi(\delta_2) = \xi(\rho_1) = \xi(\rho_3) = \xi(\mu_1) = \xi(\mu_2)$$

$\psi = 1\lambda\beta\beta$ on the fourth chain gives

$$\psi(\rho_2) > \psi(\rho_1) = \psi(\rho_3) = \psi(\mu_1) = \psi(\mu_2) = \psi(\delta_1) = \psi(\delta_2)$$

$\varpi = 1\lambda\beta\beta$ on the fifth chain gives

$$\varpi(\rho_2) > \varpi(\mu_1) = \xi(\mu_2) = \varpi(\rho_3) = \varpi(\rho_1) = \varpi(\delta_1) = \varpi(\delta_2)$$

$\tau = 1\lambda\beta\beta$ on the sixth chain gives

$$\tau(\mu_2) > \tau(\mu_1) = \tau(\rho_2) = \tau(\rho_3) = \tau(\rho_1) = \tau(\delta_1) = \tau(\delta_2)$$

$\zeta = 1\lambda\beta\beta$ on the seventh chain gives

$$\zeta(\mu_1) > \zeta(\rho_2) = \zeta(\mu_2) = \zeta(\rho_1) = \zeta(\rho_3) = \zeta(\delta_1) = \zeta(\delta_2)$$

It is clear that ξ , ψ , ϖ represent the same equivalence class of fuzzy subgroup hence will count once. The fuzzy subgroups represented by the four: μ , ν , τ and ζ are all distinct, thus we have a total of five counts for this keychain.

Similarly for other cases.

3.2 7 The Quaternion group Q_8

Q_8 is formed by the quaternions $\pm 1, \pm i, \pm j$, and $\pm k$.

$$|Q_8| = 8$$

The group is generated by i and j with $i^4 = 1$, $j^2 = i^2$ and $ji = i^3 j$

Its subgroups are,

$\{1\}$, $\{-1, 1\}$, $\{-1, 1, -i, i\}$, $\{-1, 1 - j, j\}$, $\{-1, 1, -k, k\}$ and $\{-1, 1 - i, i, -j, j, -k, k\}$. All the subgroups are normal and contain the subgroup $\{-1, 1\}$, except the trivial group $\{1\}$.

3.2.8 Maximal Chains for Q_8

There are three maximal chains for this group. These are:

$$\{1\} \subset \{-1,1\} \subset \{-1,1,-i,i\} \subset \{-1,1,-i,i,-j,j,-k,k\}$$

$$\{1\} \subset \{-1,1\} \subset \{-1,1,-j,j\} \subset \{-1,1,-i,i,-j,j,-k,k\}$$

$$\{1\} \subset \{-1,1\} \subset \{-1,1,-k,k\} \subset \{-1,1,-i,i,-j,j,-k,k\} \quad 3.3.3.2.a$$

There are four components for each chain. Therefore a keychain $1\beta\lambda\alpha$ on the maximal chain $\{1\} \subset \{-1,1\} \subset \{-1,1,-i,i\} \subset \{-1,1,-i,i,-i,i,-k,k\}$ represents a fuzzy subgroup μ as follows:

$$\mu(x) = \begin{cases} 1 & \text{if } x = e \\ \beta & \text{if } x \in \{-1,1\} \setminus \{e\} \\ \lambda & \text{if } x \in \{-1,1,-i,i\} \setminus \{-1,1\} \\ \alpha & \text{if } x \in \{-1,1,-i,i,-j,j,-k,k\} \setminus \{-1,1,-i,i\} \end{cases}$$

Since there are four components in this chain, we have 15 distinct fuzzy subgroups on this chain, represented by the keychains

$$1111 \quad 11\lambda 0 \quad 1\lambda\beta\beta$$

$$111\lambda \quad 1100 \quad 1\lambda\beta\sigma$$

$$1110 \quad 1\lambda\lambda\lambda \quad 1\lambda\beta 0$$

$$11\lambda\lambda \quad 1\lambda\lambda\beta \quad 1\lambda 00$$

$$11\lambda\beta \quad 1\lambda\lambda 0 \quad 1000$$

Using this counting technique to determine the number of fuzzy subgroups for the entire group, we obtain the following table:

Distinct Keychains	Number of counts in all chains
1111	1
111 λ	3
1110	3
11 $\lambda\lambda$	1
11 $\lambda\beta$	3

11 λ 0	3
1100	1
1 $\lambda\lambda\lambda$	1
1 $\lambda\lambda\beta$	3
1 $\lambda\lambda\lambda$	3
1 $\lambda\beta\beta$	1
1 $\lambda\beta\alpha$	3
1 $\lambda\beta\beta$	3
1 $\lambda\lambda\lambda$	1
1000	1
Total Number	31

Thus Q_8 has 31 distinct fuzzy subgroups.

3.2.9 The group Z_{p^n} for $n = 2$ and 3

A cyclic p - group is of the form $Z_{p^n}, n \in \mathbf{Z}^+, p$ a prime.

3.2.10 Maximal chains for Z_{p^n}

$Z_{p^n}, n \in \mathbf{Z}^+$ has only one maximal chain of the

form $Z_{p^n} \supset Z_{p^{n-1}} \supset Z_{p^{n-2}} \supset \dots \supset Z_{p^2} \supset Z_p \supset \{0\}$ and if the cyclic group $Z_{p^n}, n \in \mathbf{Z}^+$ contains the cyclic subgroup Z_{p^k} of order p^k , we write $Z_{p^n} \supset Z_{p^k}$, for $k \leq n$.

(a) The case $n = 1$

We have the chain $Z_p \supset \{0\}$ 3.2.9a

In 3.2.9a any fuzzy subgroup of Z_p is equivalent to any of the following:

11, 1 λ , 10 where $1 > \lambda > 0$.

$$\text{Let } \mu(x) = \begin{cases} 1 & \text{if } x = 0 \\ \lambda & \text{if } x \in Z_p \setminus \{0\} \end{cases}$$

$$\nu(x) = \begin{cases} 1 & \text{if } x = 0 \\ \lambda & \text{if } x \in Z_p \setminus \{0\} \end{cases}$$

$$\xi(x) = \begin{cases} 1 & \text{if } x = 0 \\ 0 & \text{if } x \in \mathbf{Z}_p \setminus \{0\} \end{cases}, \text{ then}$$

$\mu = 11, \nu = 1\lambda, \xi = 10$. It is clear that $\mu \neq \nu, \xi$ because by construction $1 > \lambda > 0$. Now $\mu(x) = \mu(y)$ for $x = 0, y \in \mathbf{Z}_p \setminus \{0\}$ while $\nu(x) > \nu(y)$ and $\xi(x) > \xi(y)$ for the same x and y . It is clear that μ is not equivalent to ν and ξ . We also observe that $\nu(x) > \nu(y) \Leftrightarrow \xi(x) > \xi(y)$ but the $\text{supp } \nu \neq \text{supp } \xi$, therefore ν is not equivalent to ξ . Since there is only one chain, each keychain counts once on the maximal chain, resulting in three distinct equivalence classes of fuzzy subgroups for this group.

(b) The case $n = 2$

We have the maximal chain $\mathbf{Z}_{p^2} \supset \mathbf{Z}_p \supset \{0\}$ with seven distinct classes of fuzzy subgroups viz $111, 11\lambda, 110, 1\lambda\lambda, 1\lambda\beta, 1\lambda 0$ and 100 .

From the above it is clear that using the equivalence stated in section 2.0

$\mu = 111$ and $\nu = 11\lambda$ are not equivalent as

$$\mu(x) = \mu(y) \text{ for } x \in \mathbf{Z}_p \setminus \{0\}, y \in \mathbf{Z}_{p^2} \setminus \mathbf{Z}_p \text{ but } \nu(x) > \nu(y) \text{ for the same } x \text{ and } y \text{ because by assertion } 1 > \lambda.$$

Now we observe that $7 = 2^{2+1} - 1$.

A similar argument can be used to show that the maximal chain

$\mathbf{Z}_{p^3} \supset \mathbf{Z}_{p^2} \supset \mathbf{Z}_p \supset \{0\}$ of the group \mathbf{Z}_{p^3} has 15 distinct fuzzy subgroups and $15 = 2^{3+1} - 1$. This suggests theorem 3.2.11.

Theorem: 3.2.11

For any $n \in \mathbf{N}$ there are $2^{n+1} - 1$ distinct equivalence classes of fuzzy subgroups on \mathbf{Z}_{p^n} .

Proof (See Proposition 3.3 [25])

3.2.12 On the group $G = \mathbb{Z}_{p^n} + \mathbb{Z}_q$ where p and q are distinct primes

and $n \in \mathbb{N}$.

Theorem: 3.2.13

The number of maximal chains for the group $G = \mathbb{Z}_{p^n} + \mathbb{Z}_q$ is $(n+1)$ for $n \geq 1$.

Proof

Straightforward. (See illustrations, Figures 1, 2 and 3 under list of figures)

3.2.14 The number of fuzzy subgroups of the group $G = \mathbb{Z}_{p^n} + \mathbb{Z}_q$ where

p and q are distinct primes and $n \in \mathbb{N}$

In this section we want to determine a general formula for the number of distinct fuzzy subgroups for the group $G = \mathbb{Z}_{p^n} + \mathbb{Z}_q$ where p and q are distinct primes (also derived in [25]). We advance a few values of n to motivate theorem 3.2.18. Although a proof of the same theorem was given by Murali and Makamba in [25], we give a different version of the proof as a way of illustrating how our method of pin-extension is used.

3.2.15 The case $n = 1$ that is $G = \mathbb{Z}_p + \mathbb{Z}_q$

From theorem 3.2.13 with $n = 1$, $G = \mathbb{Z}_p + \mathbb{Z}_q$ has $(1+1) = 2$ maximal chains and these are:

$$O \subset \mathbb{Z}_p + \{0\} \subset \mathbb{Z}_p + \mathbb{Z}_q$$

$$O \subset \{0\} + \mathbb{Z}_q \subset \mathbb{Z}_p + \mathbb{Z}_q$$

Each maximal chain has three components, thus corresponding to each maximal chain there are seven distinct equivalence classes of fuzzy subgroups given by the keychains 111 , 110 , $1\lambda\beta$, 100 , 11λ , $1\lambda\lambda$ and $1\lambda 0$.

If the two chains are considered, we obtain a total of eleven non-equivalent fuzzy subgroups as explained below:

The keychains $111, 1\lambda\lambda, 100$ each represents the same fuzzy subgroup if both maximal chains are considered, thus giving a total of three non-equivalent fuzzy subgroups. The keychains $11\lambda, 110, 1\lambda\beta$ and $1\lambda 0$ each behaves as a unique fuzzy subgroup with reference to each maximal chain, hence each counts twice giving a total of eight non-equivalent fuzzy subgroups. This gives a total of eleven non-equivalent fuzzy subgroups for the group.

Below we explain how we arrive at this number of counts:

Suppose we take for example the keychain 111, it gives a count of one in both chains because it is the same fuzzy subgroup in both cases, (that is $\mu(x) = 1, \forall x \in \mathbf{Z}_p \times \mathbf{Z}_q$).

We observe that if we let $\mu = 11\lambda$ and $\nu = 11\lambda$ for the first and second chains respectively, then $\mu(x) > \mu(y)$ but $\nu(y) > \nu(x)$ for the same $x \in \mathbf{Z}_p \times \{0\}$ and $y \in \{0\} \times \mathbf{Z}_q$, therefore the same keychain represents different equivalence classes of fuzzy subgroups when observed in the context of each chain, thus the count two. A similar argument holds for the double count of the rest.

3.2.16 The case $n = 2$ that is the group $\mathbf{Z}_{p^2} \times \mathbf{Z}_q$

For this group $n = 2$, therefore we have $(2 + 1) = 3$ maximal chains by Theorem 3.2.13 and these are:

$$\mathbf{Z}_{p^2} + \mathbf{Z}_q \supset \mathbf{Z}_p + \mathbf{Z}_q \supset \mathbf{Z}_p + \{0\} \supset \{0\}$$

$$\mathbf{Z}_{p^2} + \mathbf{Z}_q \supset \mathbf{Z}_p + \mathbf{Z}_q \supset \{0\} + \mathbf{Z}_q \supset \{0\}$$

$$\mathbf{Z}_{p^2} + \mathbf{Z}_q \supset \mathbf{Z}_{p^2} + \{0\} \supset \mathbf{Z}_p + \{0\} \supset \{0\}$$

There are four levels for each chain. Thus corresponding to the chain

$$\mathbf{Z}_{p^2} + \mathbf{Z}_q \supset \mathbf{Z}_{p^2} + \{0\} \supset \mathbf{Z}_p + \{0\} \supset \{0\} \text{ for example we have 15 distinct equivalence}$$

classes of fuzzy subgroups as listed below

$$1111 \quad 11\lambda 0 \quad 1\lambda\beta\beta$$

$$111\lambda \quad 1100 \quad 1\lambda\beta\alpha$$

$$1110 \quad 1\lambda\lambda\lambda \quad 1\lambda\beta 0$$

$$11\lambda\lambda \quad 1\lambda\lambda\beta \quad 1\lambda 00$$

$$11\lambda\beta \quad 1\lambda\lambda 0 \quad 1000, \text{ where } 1 > \lambda > \beta > \alpha > 0$$

Considering all the chains it can be shown using this counting technique that there are 31 distinct equivalence classes of fuzzy subgroups.

Remark: This is how the counting technique goes: for example the keychain 1111 counts once in all the maximal chains because it is the same fuzzy subgroup in all cases (that is $\mu(x) = 1, \forall x \in \mathbf{Z}_{p^2} \times \mathbf{Z}_q$).

The keychain 111 λ counts twice if all chains are considered because if we let $\mu = 111\lambda$, $\nu = 111\lambda$ and $\xi = 111\lambda$ be three keychains corresponding to the first,

second and third chains respectively, they are distinct fuzzy subgroups since for the same $x \in \mathbf{Z}_p \times \mathbf{Z}_q$ and $y \in \mathbf{Z}_p \times \mathbf{O}$ we have $\mu(x) > \mu(y)$ but $\nu(y) < \nu(x)$ and $\xi(x) < \xi(y)$ for example $x = (0,1)$, $y = (p,0)$. In other words the keychain 111λ on the first and second maximal chains represent the same fuzzy subgroup while it represents a different equivalence class on the third maximal chain.

Now using this counting technique, we have the following table which completes the entire count

Distinct Keychains	Number of counts in all chains
1111	1
111 λ	2
1110	2
11 $\lambda\lambda$	2
11 $\lambda\beta$	3
11 $\lambda 0$	3
1100	2
1 $\lambda\lambda\lambda$	1
1 $\lambda\lambda\beta$	2
1 $\lambda\lambda 0$	2
1 $\lambda\beta\beta$	2
1 $\lambda\beta\alpha$	3
1 $\lambda\beta 0$	3
1 $\lambda 00$	2
1000	1
Total Number of	31

Therefore the group $G = \mathbf{Z}_{p^2} \times \mathbf{Z}_q$ has 31 distinct fuzzy subgroups. We observe that

$$31 = 8(4) - 1 = 2^{2+1}(2+2) - 1.$$

3.2.17 The case when $n = 3$ that is $\mathbf{Z}_{p^3} \times \mathbf{Z}_q$

For the group $G = \mathbf{Z}_{p^3} \times \mathbf{Z}_q$ we have $n = 3$, thus we have 4 maximal chains for this group. These are:

$$\{0\} \subset \mathbf{Z}_p + \{0\} \subset \mathbf{Z}_p + \mathbf{Z}_q \subset \mathbf{Z}_{p^2} + \mathbf{Z}_q \subset \mathbf{Z}_{p^3} + \mathbf{Z}_q \quad (\text{a})$$

$$\{0\} \subset \mathbf{Z}_p + \{0\} \subset \mathbf{Z}_{p^2} + \{0\} \subset \mathbf{Z}_{p^3} + \{0\} \subset \mathbf{Z}_{p^3} + \mathbf{Z}_q \quad (\text{b})$$

$$\{0\} \subset \mathbf{Z}_p + \{0\} \subset \mathbf{Z}_{p^2} + \{0\} \subset \mathbf{Z}_{p^2} + \mathbf{Z}_q \subset \mathbf{Z}_{p^3} + \mathbf{Z}_q \quad (\text{c})$$

$$\{0\} \subset \{0\} + \mathbf{Z}_q \subset \mathbf{Z}_{p^2} + \mathbf{Z}_q \subset \mathbf{Z}_{p^2} + \mathbf{Z}_q \subset \mathbf{Z}_{p^3} + \mathbf{Z}_q \quad (\text{d})$$

There are five levels for each maximal chain. Corresponding to each maximal chain we have 31 distinct fuzzy subgroups, given by the keychains:

11111, 1111 λ , 11110, 111 $\lambda\lambda$, 111 $\lambda\beta$, 111 $\lambda 0$, 11100, 11 $\lambda\lambda\lambda$, 11 $\lambda\lambda\beta$, 11 $\lambda\lambda 0$,
11 $\lambda\beta\beta$, 11 $\lambda\beta\delta$, 11 $\lambda\beta 0$, 11 $\lambda 00$, 11000, 1 $\lambda\lambda\lambda\lambda$, 1 $\lambda\lambda\lambda\beta$, 1 $\lambda\lambda\lambda 0$, 1 $\lambda\lambda\beta\beta$, 1 $\lambda\lambda\beta\delta$,
1 $\lambda\lambda\beta 0$, 1 $\lambda\lambda 00$, 1 $\lambda\beta\beta\beta$, 1 $\lambda\beta\beta\delta$, 1 $\lambda\beta\beta 0$, 1 $\lambda\beta\delta\delta$, 1 $\lambda\beta\delta\gamma$, 1 $\lambda\beta\delta 0$, 1 $\lambda\beta 00$, 1 $\lambda 000$ and
10000.

If all these distinct fuzzy subgroups are taken individually for all the four chains we get 79 non-equivalent fuzzy subgroups for the group $G = \mathbf{Z}_{p^3} + \mathbf{Z}_q$. We also observe

$$\text{that } 2^{3+1}(3+2) - 1 = 2^4(5) - 1 = 80 - 1 = 79.$$

This motivates theorem 3.2.18.

Theorem: 3.2.18

The number of distinct fuzzy subgroups for the group $G = \mathbf{Z}_{p^n} + \mathbf{Z}_q$ is $2^{n+1}(n+2) - 1$ for $n \in \mathbb{N}$.

Proof

We prove by induction on n . The formula holds for $n = 1, 2$ and 3 as shown above.

Suppose the statement is true for $n = k$, that is $G = \mathbf{Z}_{p^k} + \mathbf{Z}_q$ has $2^{k+1}(k+2) - 1$

distinct fuzzy subgroups. We are going to make use of the lattice diagram of

subgroups of $\mathbf{Z}_{p^k} + \mathbf{Z}_q$ and extend from the two nodes p^k and $p^k q$ to the lattice

diagram of subgroups of $\mathbf{Z}_{p^{k+1}} + \mathbf{Z}_q$. The subgroup $\mathbf{Z}_{p^k} + \mathbf{Z}_q$ is written as $p^k q$ or

simply $p^k q$.

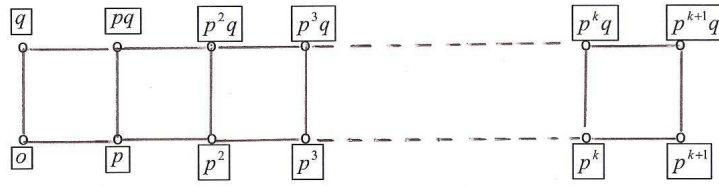

We show that the theorem is true for $n = k + 1$. The number of fuzzy subgroups of $Z_{p^k} + Z_q$ that end with a nonzero pin is one more than those that end with a zero pin.

Thus the node (subgroup) $p^k q$ has $\frac{[(2^{k+1}(k+2)-1)+1]}{2} = \frac{2^{k+1}(k+2)}{2}$ non-

equivalent fuzzy subgroups ending with a nonzero pin, and there are $\frac{2^{k+1}(k+2)}{2} - 1$

fuzzy subgroups ending with a zero pin. Each of the former yields three distinct fuzzy subgroups in the subgroup $p^{k+1}q$ as follows: A keychain in $p^k q$ is of the form

$1\alpha_1\alpha_2\dots\alpha_k$. Now for $\alpha_k \neq 0$, we can only extend to $1\alpha_1\alpha_2\dots\alpha_k\alpha_k$, $1\alpha_1\alpha_2\dots\alpha_k\beta$ and

$1\alpha_1\alpha_2\dots\alpha_k 0$ keychains in $p^{k+1}q$ for $0 < \beta < \alpha_k$. Therefore $\frac{2^{k+1}(k+2)}{2}$ yields

$\frac{2^{k+1}(k+2)}{2} \times 3$ fuzzy subgroups in $p^{k+1}q$ and $\frac{2^{k+1}(k+2)}{2} - 1$ remains the same

because on zero we can only attach a zero. The node p^k has $2^{k+1} - 1$ non-equivalent fuzzy subgroups from theorem 3.2.11. Similarly there are $\frac{[(2^{k+1}-1)+1]}{2} = \frac{2^{k+1}}{2}$ fuzzy

subgroups that will give rise to new fuzzy subgroups when applied to extensions.

Suppose $1\alpha_1\alpha_2\dots\alpha_k$ is a keychain in p^k with $\alpha_k \neq 0$. Extending p^k to $p^{k+1}q$ we

obtain seven keychains viz: $1\alpha_1\alpha_2\dots\alpha_k\alpha_k\alpha_k$, $1\alpha_1\alpha_2\dots\alpha_k\alpha_k\beta$, $1\alpha_1\alpha_2\dots\alpha_k\alpha_k 0$,

$1\alpha_1\alpha_2\dots\alpha_k\beta\beta$, $1\alpha_1\alpha_2\dots\alpha_k\beta\alpha$, $1\alpha_1\alpha_2\dots\alpha_k\beta 0$ and $1\alpha_1\alpha_2\dots\alpha_k 00$ for $0 < \beta < \alpha_k$ and

$0 < \alpha < \beta$.

Three have been counted before viz $1\alpha_1\alpha_2\dots\alpha_k\alpha_k\alpha_k$, $1\alpha_1\alpha_2\dots\alpha_k\beta\beta$, $1\alpha_1\alpha_2\dots\alpha_k 00$,

through $p^k q$. Thus $\frac{2^{k+1}}{2}$ yields $\frac{2^{k+1}}{2} \times 4$ keychains in $p^{k+1}q$.

Similarly keychains in p^k ending with zero do not contribute new fuzzy subgroups as these have been counted when extending from $p^k q$ to $p^{k+1} q$.

$$\begin{aligned} \text{Summing up we get } & \frac{2^{k+1}(k+2)}{2} \times 3 \\ & + \frac{2^{k+1}(k+2)}{2} - 1 + \frac{2^{k+1}}{2} \times 4 = 2^k(k+2) - 1 + 3 \times 2^k(k+2) + 2^{k+2} \\ & = 2^{k+2}(k+3) - 1 = 2^{k+2}((k+1)+2) - 1. \end{aligned}$$

This completes the proof. \square

3.3 Isomorphic Classes of Fuzzy Subgroups

A mathematical object usually consists of a set and some mathematical relations and operations defined on the set. A collection of mathematical objects that are isomorphic form an isomorphism class. In defining isomorphism classes therefore the properties of the structure of the mathematical object are studied and the names of the elements of the set considered are irrelevant.

Definition: 3.3.1

An isomorphism class is an equivalence class for the equivalence relation defined on a group by an isomorphism.

We are going to use the definition of isomorphism given in section 2.4.4. The notion of equivalence is a special case of fuzzy isomorphism, that is if two fuzzy subgroups are equivalent then they are isomorphic but not vice versa.

Definition: 3.3.2

Two or more maximal chains are isomorphic if their lengths are equal and the corresponding components are isomorphic subgroups.

3.3.3 Number of Isomorphic classes for selected finite groups:

3.3.3.1 The symmetric group S_3 (see section 3.2.1)

S_3 has the following maximal chains. (3.1.2 a)

- $\{e\} \subset B_0 \subset S_3$ (i)
- $\{e\} \subset B_1 \subset S_3$ (ii)
- $\{e\} \subset B_2 \subset S_3$ (iii)
- $\{e\} \subset B_3 \subset S_3$ (iv)

We observe that chain (i) is not isomorphic to the other chains (ii) and (iii) which are isomorphic to each other, therefore will be viewed as distinct from others. But (ii) and (iii) will be viewed as one chain. So calculating the number of isomorphic classes of fuzzy subgroups we obtain the following in tabular form:

Distinct Keychains	Number of ways each Keychain counts
111	1
11λ	2
110	2
$1\lambda\lambda$	1
$1\lambda\beta$	2
$1\lambda 0$	2
100	1
Total number of isomorphic classes	11

Comments

For the group S_3 we have fewer isomorphic classes of fuzzy subgroups than equivalence classes.

3.3.3.2 The Quaternion group Q_8

This group has the following maximal chains as presented in chapter three.

- $\{1\} \subset \{-1,1\} \subset \{-1,1,-i,i\} \subset \{-1,1,-i,i,-j,j,-k,k\}$ **
- $\{1\} \subset \{-1,1\} \subset \{-1,1,-j,j\} \subset \{-1,1,-i,i,-j,j,-k,k\}$ ***
- $\{1\} \subset \{-1,1\} \subset \{-1,1,-k,k\} \subset \{-1,1,-i,i,-j,j,-k,k\}$ ****

(**), (***) and (****) are all isomorphic since by construction $i^2 = j^2 = k^2 = -1$ they are viewed as one chain when computing the number of isomorphic classes. In section 3.3.0 we established that each chain has 15 non-equivalent fuzzy subgroups that can be represented by the following symbols:

- 1111 11 λ 0 $1\lambda\beta\beta$ 111 λ 1100 $1\lambda\beta\sigma$ 1110 $1\lambda\lambda\lambda$ $1\lambda\beta 0$ 11 $\lambda\lambda$ $1\lambda\lambda\beta$ 1 λ 00
- $11\lambda\beta$ $1\lambda\lambda 0$ 1000

Since all chains count as one, there are 15 isomorphic classes of fuzzy subgroups for Q_8 .

Note: There are fewer isomorphic classes of fuzzy subgroups than equivalence classes.

3.3.3.3 The group $G = \mathbb{Z}_p + \mathbb{Z}_q$

This group has the following maximal chains

$$\{0\} \subset \mathbb{Z}_p + \{0\} \subset \mathbb{Z}_p + \mathbb{Z}_q$$

$$\{0\} \subset \{0\} + \mathbb{Z}_q \subset \mathbb{Z}_p + \mathbb{Z}_q$$

The two chains are not isomorphic, thus each contributes to the number of isomorphic classes. We established in chapter three that there are 7 distinct fuzzy subgroups for each chain, these are:

$$111 \quad 110 \quad 1\lambda\beta \quad 100 \quad 11\lambda \quad 1\lambda\lambda \quad 1\lambda 0.$$

First we present a table of keychains and the number of isomorphic classes represented by each keychain. We count these as in the case of equivalence classes and obtain the following table:

Distinct Keychains	Number of ways each Keychain counts
111	1
11 λ	2
110	2
1 $\lambda\lambda$	1
1 $\lambda\beta$	2
1 $\lambda 0$	2
100	1
Total number of isomorphic classes	11

We observe that the number of equivalent fuzzy subgroups is equal to the number of isomorphic classes for this group.

3.3.3.4 The group $G = \mathbb{Z}_{p^2} + \mathbb{Z}_q$

There are three maximal chains for this group as shown below:

$$\mathbb{Z}_{p^2} + \mathbb{Z}_q \supset \mathbb{Z}_p + \mathbb{Z}_q \supset \mathbb{Z}_p + \{0\} \supset \{0\} \quad (\text{i})$$

$$\mathbb{Z}_{p^2} + \mathbb{Z}_q \supset \mathbb{Z}_p + \mathbb{Z}_q \supset \{0\} + \mathbb{Z}_q \supset \{0\} \quad (\text{ii})$$

$$\mathbf{Z}_{p^2} + \mathbf{Z}_q \supset \mathbf{Z}_{p^2} + \{0\} \supset \mathbf{Z}_p + \{0\} \supset \{0\} \quad (\text{iii})$$

We observe that chain (iii) contains a cyclic subgroup $\mathbf{Z}_{p^2} + \{0\}$, therefore is not isomorphic to either (i) and (ii). Also (i) and (ii) are not isomorphic because p and q are different primes. Thus the number of isomorphic classes of fuzzy subgroups is equal to the number of equivalence classes for this group.

So for the group $\mathbf{Z}_{p^n} + \mathbf{Z}_q$, the number of isomorphic classes of fuzzy subgroups is equal to the number of equivalence fuzzy subgroups and is given by the formula $2^{n+1}(n+2) - 1$. (See theorem 3.4 [25])

Now if we investigate the group $G = \mathbf{Z}_p + \mathbf{Z}_p$, we start with for example $\mathbf{Z}_2 + \mathbf{Z}_2$ which has the following maximal chains

$$\{0\} \subset \mathbf{Z}_2 + \{0\} \subset \mathbf{Z}_2 + \mathbf{Z}_2$$

$$\{0\} \subset \{0\} + \mathbf{Z}_2 \subset \mathbf{Z}_2 + \mathbf{Z}_2$$

$$\{0\} \subset \langle (1,1) \rangle \subset \mathbf{Z}_2 + \mathbf{Z}_2$$

they are all isomorphic thus $\mathbf{Z}_2 + \mathbf{Z}_2$ has $2^3 - 1$ isomorphic classes but has

$2^3 - 1 + \frac{2^3}{2} \times 2$ equivalence classes of fuzzy subgroups.

In general $G = \mathbf{Z}_p + \mathbf{Z}_p$ has only proper subgroups of orders p and 1. All subgroups of order p are isomorphic, hence all the maximal chains are isomorphic which implies that $G = \mathbf{Z}_p + \mathbf{Z}_p$ has $2^3 - 1 = 7$ isomorphic classes of fuzzy subgroups for all primes p .

For the group $G = \mathbf{Z}_{2^2} + \mathbf{Z}_2$ we have the following maximal chains

$$\{0\} \subset \mathbf{Z}_2 + \{0\} \subset \mathbf{Z}_{2^2} + \{0\} \subset \mathbf{Z}_{2^2} + \mathbf{Z}_2$$

$$\{0\} \subset \mathbf{Z}_2 + \{0\} \subset \langle (1,1) \rangle \subset \mathbf{Z}_{2^2} + \mathbf{Z}_2$$

$$\{0\} \subset \{0\} + \mathbf{Z}_2 \subset \mathbf{Z}_2 + \mathbf{Z}_2 \subset \mathbf{Z}_{2^2} + \mathbf{Z}_2$$

$$\{0\} \subset \langle (2,1) \rangle \subset \mathbf{Z}_2 + \mathbf{Z}_2 \subset \mathbf{Z}_{2^2} + \mathbf{Z}_2$$

The last two maximal chains are isomorphic and will be viewed as one chain while the first two are also isomorphic

So the number of isomorphic classes of fuzzy subgroups for $G = \mathbf{Z}_{2^2} + \mathbf{Z}_2$ is

$2^4 - 1 + \frac{2^4}{2} = 23$. Similarly it can be shown that the group $G = \mathbf{Z}_{2^3} + \mathbf{Z}_2$ has

$2^5 - 1 + \frac{2^5}{2} \times (2) = 63$ isomorphic classes of fuzzy subgroups.

Chapter Four

ON THE MAXIMAL CHAINS OF THE GROUPS $G = \mathbb{Z}_{p^n} + \mathbb{Z}_{q^m}$ AND

$$G = \mathbb{Z}_{p^n} + \mathbb{Z}_{q^m} + \mathbb{Z}_{r^s}$$

4.0 Introduction

Since the concept of maximal chains plays a crucial role in facilitating the characterization of fuzzy subgroups of particular groups, in this section we wish to determine a formula for the number of maximal chains for the

group $G = \mathbb{Z}_{p^n} + \mathbb{Z}_{q^m} + \mathbb{Z}_r$ and possibly conjecture on the formula for the group

$G = \mathbb{Z}_{p^n} + \mathbb{Z}_{q^m} + \mathbb{Z}_{r^s}$ for all values of $n, m, s \in \mathbb{Z}^+$ and for all p, q and r distinct

primes. To accomplish this we first begin with studying the group $G = \mathbb{Z}_{p^n} + \mathbb{Z}_{q^m}$.

Ngcibi in [30] studied the classification of abelian groups of the form $G = \mathbb{Z}_{p^n} + \mathbb{Z}_p$

and obtained the following results which we put down in the form of lemmas without proof.

4.1 Maximal Chains of $G = \mathbb{Z}_{p^n} + \mathbb{Z}_p$

Lemma: 4.1.0

$G = \mathbb{Z}_p + \mathbb{Z}_p$ has $p + 1$ maximal chains.

Proof [30]

Lemma: 4.1.1

$G = \mathbb{Z}_{p^2} + \mathbb{Z}_p$ has $2p + 1$ maximal chains.

Proof [30]

Lemma: 4.1.2

$G = \mathbb{Z}_{p^3} + \mathbb{Z}_p$ has $3p + 1$ maximal chains.

Proof [30]

Lemma: 4.1.3

$G = \mathbb{Z}_{p^n} + \mathbb{Z}_p$ has $(n - 1)(p - 1) + (p + 1)$ maximal chains.

Proof[30]

We also include the following definition that will be used in the decomposition of groups when determining the number of maximal chains of these selected groups.

Definition: 4.1.4

A maximal subgroup G' of a group G is a proper subgroup of G such that no proper subgroup G'' of G strictly contains G' .

4.1.5 Maximal Chains of $G = \mathbb{Z}_{p^n} + \mathbb{Z}_{q^m}$

Since our ultimate goal is to establish the formula for the number of maximal chains for the group $G = \mathbb{Z}_{p^n} + \mathbb{Z}_{q^m}$, we accomplish this by fixing m and for that particular value of m , values of n are advanced to identify a pattern.

When $m = 1$ we have $G = \mathbb{Z}_{p^n} + \mathbb{Z}_q$ and advancing a few values of n say $n = 1, 2, 3, 4$ we observe that here are $(n + 1)$ maximal chains (see tree diagrams of subgroups for $n = 1, 2, 3$ and 4 (Figures One, Two and Three)) and by symmetry $G = \mathbb{Z}_p + \mathbb{Z}_{q^m}$ has $(m + 1)$ maximal chains.

We denote the group $G = \mathbb{Z}_{p^n} + \mathbb{Z}_{q^m}$ by $p^n q^m$

Figure One

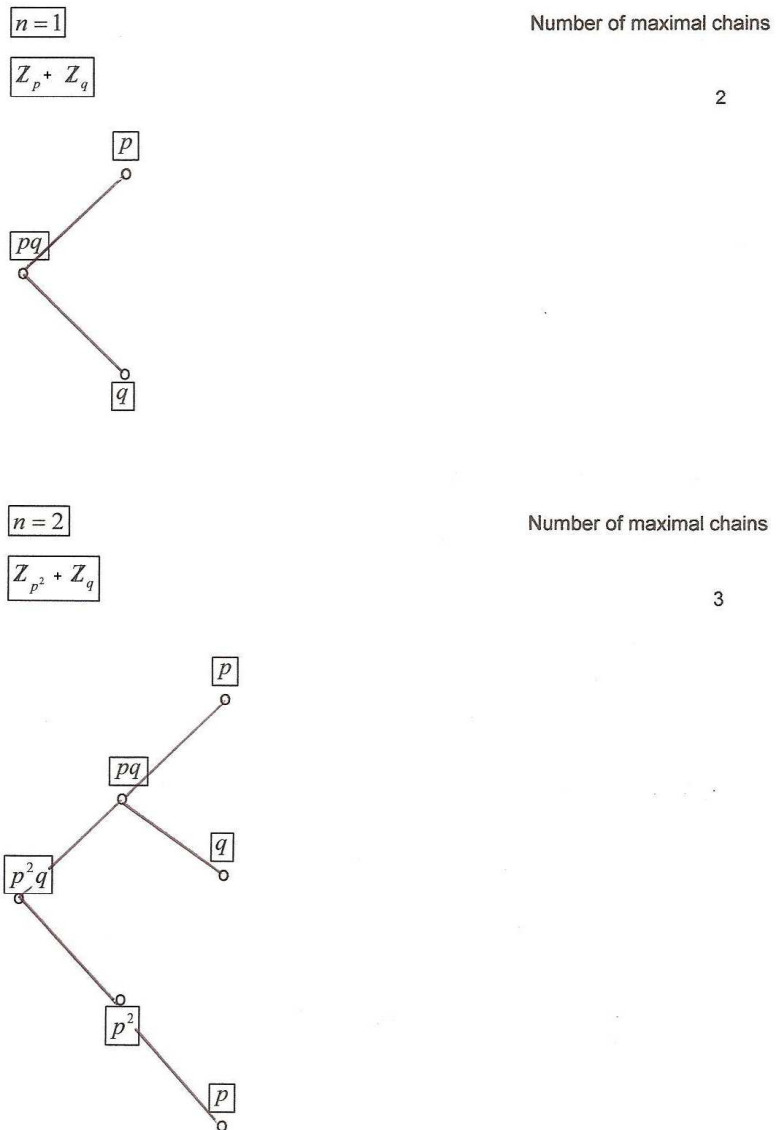

Figure Two

$$n = 3$$

$$\mathbb{Z}_{p^3} + \mathbb{Z}_q$$

Number of maximal chains

4

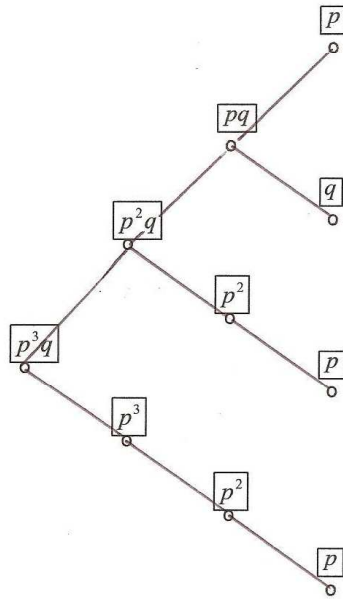
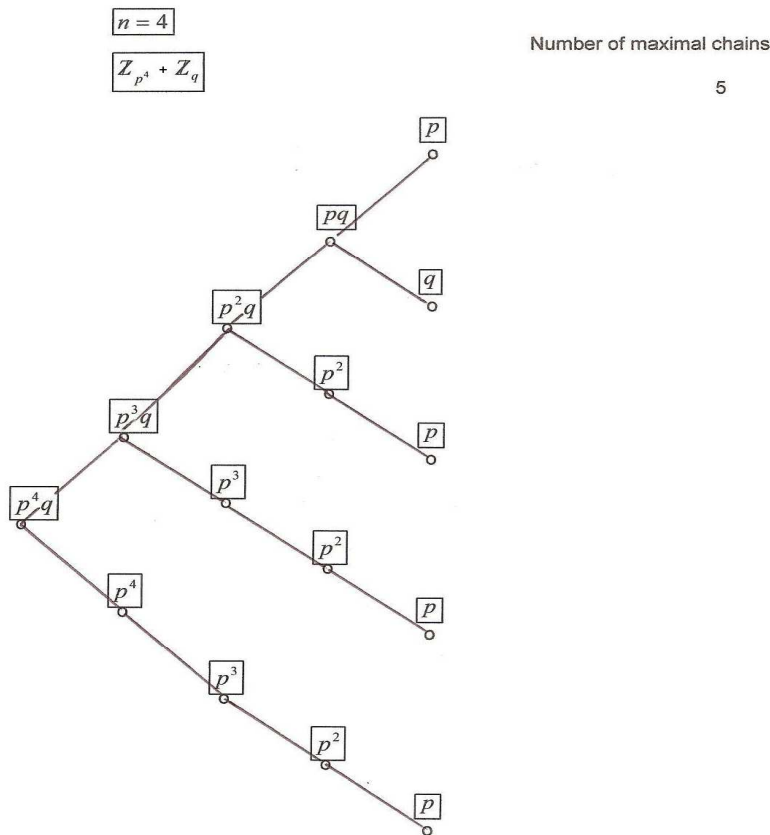

Figure Three

**Proposition: 4.1.6**

$G = \mathbb{Z}_{p^n} + \mathbb{Z}_q$ has $(n + 1)$ maximal chains.

Proof

From the tree diagrams above the formula is true for $n = 1, 2, 3, 4$. We assume the formula is true for $n = k$, that is $\mathbb{Z}_{p^k} + \mathbb{Z}_q$ has $(k + 1)$ maximal chains. Now we need to show that $\mathbb{Z}_{p^{k+1}} + \mathbb{Z}_q$ has $(k + 2)$ maximal chains. $\mathbb{Z}_{p^{k+1}} + \mathbb{Z}_q$ has the following maximal subgroups (i) $\mathbb{Z}_{p^k} + \mathbb{Z}_q$ and (ii) $\mathbb{Z}_{p^{k+1}}$. Now (i) by assumption has $(k + 1)$ maximal chains and (ii) from section 3.2.10 has one maximal chain. Summing we have $(k + 1) + 1 = (k + 2)$ maximal chains as required. \square

Furthermore, continuing with the process we obtain the following number of maximal chains for different values of m .

M	Group	Number of Maximal chains
2	$Z_{p^n} + Z_{q^2}$	$\frac{(n+2)!}{n!2!}$
3	$Z_{p^n} + Z_{q^3}$	$\frac{(n+3)!}{n!3!}$
4	$Z_{p^n} + Z_{q^4}$	$\frac{(n+4)!}{n!4!}$
5	$Z_{p^n} + Z_{q^5}$	$\frac{(n+5)!}{n!5!}$

The above observation motivates the following proposition.

Proposition: 4.1.7

The number of maximal chains for $G = Z_{p^n} + Z_{q^m}$ is $\frac{(n+m)!}{n!m!}$, for all $n, m \in \mathbb{Z}^+$.

Proof

We prove by inducting on the sum of the exponents of p and q that is $n+m$. Now if we let $s = n+m$, the formula is true for $s=1$ because we have either $n=1$ and $m=0$ or $n=0$ and $m=1$. G is isomorphic to the group Z_p or Z_q which has one

maximal chain and $\frac{(0+1)!}{1!0!} = 1$. For $s=2$, we may have $n=2$ and $m=0$ or $n=2$ and

$m=0$, making G isomorphic to the groups Z_{p^2} or Z_{q^2} with one maximal chain and

$\frac{(0+2)!}{2!0!} = 1$. We may also have $n=1$ and $m=1$, thus G is isomorphic to the group

$Z_p + Z_q$ which has $2 = \frac{(1+1)!}{1!1!}$ maximal chains, therefore the formula holds for

$s=2$.

Now we assume the formula holds for $s=k \Rightarrow n+m=k \Rightarrow m=k-n$ so that

$G = Z_{p^n} + Z_{q^{k-n}}$ has $\frac{s!}{n!(k-n)!} = \frac{k!}{n!(k-n)!}$ maximal chains. We need to show that

when $G = \mathbf{Z}_{p^n} + \mathbf{Z}_{q^{k-n+1}}$ there are $\frac{(n+k-n+1)!}{n!(k-n+1)!} = \frac{(k+1)!}{n!(k-n+1)!}$ maximal chains. The

maximal subgroups of $\mathbf{Z}_{p^n} + \mathbf{Z}_{q^{k-n+1}}$ are $\mathbf{Z}_{p^{n-1}} + \mathbf{Z}_{q^{k-n+1}}$ (a) and $\mathbf{Z}_{p^n} + \mathbf{Z}_{q^{k-n}}$ (b)

From (a) and (b) using assumption, we have that $\mathbf{Z}_{p^{n-1}} + \mathbf{Z}_{q^{k-n+1}}$ has

$\frac{(n-1+k-n+1)!}{(n-1)!(k-n+1)!} = \frac{k!}{(n-1)!(k-n+1)!}$ maximal chains and $\mathbf{Z}_{p^n} + \mathbf{Z}_{q^{k-n}}$ has

$\frac{(n+k-n)!}{n!(k-n)!} = \frac{k!}{n!(k-n)!}$ maximal chains.

Adding we obtain $\frac{k!}{(n-1)!(k-n+1)!} + \frac{k!}{n!(k-n)!} = \frac{k!(n) + k!(k-n+1)}{n!(k-n+1)!}$
 $= \frac{k![n+k-n+1]}{n!(k-n)!} = \frac{k!(k+1)}{n!(k-n+1)!} = \frac{(k+1)!}{n!(k-n+1)!}$. This completes

the proof. □

4.2 Maximal Chains of $G = \mathbf{Z}_{p^n} + \mathbf{Z}_q + \mathbf{Z}_r$

Utilizing the tree diagram of subgroups below and executing a similar technique like above, we obtain the number of maximal chain for the group $G = \mathbf{Z}_{p^n} + \mathbf{Z}_q + \mathbf{Z}_r$, in tabular form for any $n \in \mathbf{Z}^+$.

The group $G = \mathbf{Z}_p + \mathbf{Z}_q + \mathbf{Z}_r$ has the following maximal chains:

$$n=1$$

$$G = Z_p + Z_q + Z_r$$

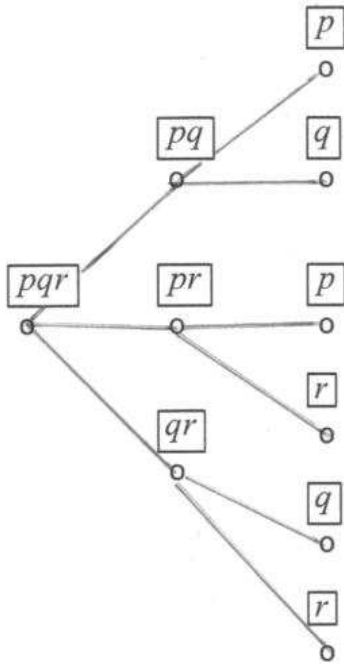

Number of maximal chains=6

$$= \frac{(1+1+1)!}{1!}$$

The group $G = \mathbb{Z}_{p^2} + \mathbb{Z}_q + \mathbb{Z}_r$ has the following maximal chains:

$$n = 2$$

$$G = \mathbb{Z}_{p^2} + \mathbb{Z}_q + \mathbb{Z}_r$$

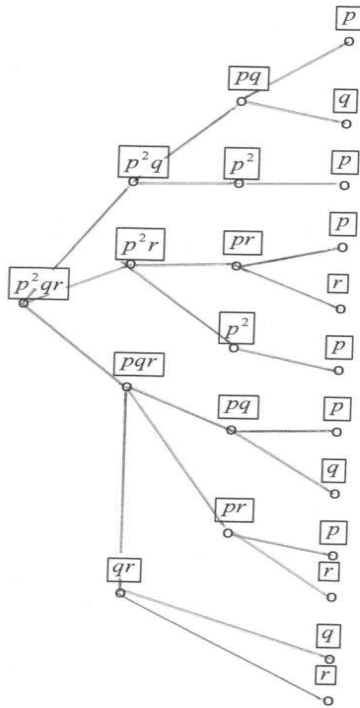

Number of Maximal chains = 12

$$= \frac{(2+1+1)!}{2!}$$

n	$\mathbb{Z}_{p^n} + \mathbb{Z}_q + \mathbb{Z}_r$	Number of Maximzl Chains
1	$\mathbb{Z}_p + \mathbb{Z}_q + \mathbb{Z}_r$	$6=(1+1)(1+2)$
2	$\mathbb{Z}_{p^2} + \mathbb{Z}_q + \mathbb{Z}_r$	$12=(2+1)(2+2)$
3	$\mathbb{Z}_{p^3} + \mathbb{Z}_q + \mathbb{Z}_r$	$20=(3+1)(3+2)$
.	.	.
.	.	.
.	.	.
k	$\mathbb{Z}_{p^k} + \mathbb{Z}_q + \mathbb{Z}_r$	$k^2 + 3k + 2 = (k+1)(k+2)$

From this table we can deduce that the number of maximal chains for

$G = \mathbf{Z}_{p^n} + \mathbf{Z}_q + \mathbf{Z}_r$ is a polynomial in n and we state this as a lemma that follows.

Lemma: 4.2.1

The group $G = \mathbf{Z}_{p^n} + \mathbf{Z}_q + \mathbf{Z}_r$ has $(n+1)(n+2) = \frac{(n+1+1)!}{n!}$ maximal chains for

$n \geq 1$.

Proof

We induct on n . From the illustration on tree diagrams and the chart above we observe that the formula holds for $n = 1, 2, 3$. Now we assume that the formula holds for $n = k$ that is $G = \mathbf{Z}_{p^k} + \mathbf{Z}_q + \mathbf{Z}_r$ has $(k+1)(k+2)$ maximal chains. We have to show that $G = \mathbf{Z}_{p^{k+1}} + \mathbf{Z}_q + \mathbf{Z}_r$ has $(k+2)(k+3)$ maximal chains.

Now $G = \mathbf{Z}_{p^{k+1}} + \mathbf{Z}_q + \mathbf{Z}_r$ has the following maximal subgroups

$$\mathbf{Z}_{p^k} + \mathbf{Z}_q + \mathbf{Z}_r \quad (\text{a})$$

$$\mathbf{Z}_{p^{k+1}} + \mathbf{Z}_q + \{0\} \quad (\text{b})$$

$$\mathbf{Z}_{p^{k+1}} + \{0\} + \mathbf{Z}_r \quad (\text{c})$$

From assumption, (a) has $(k+1)(k+2)$, (b) and (c), from previous result 4.1.7 have

$$\frac{(k+1+1)!}{(k+1)!} \quad \text{and} \quad \frac{(k+1+1)!}{(k+1)!} \quad \text{maximal chains respectively.}$$

Summing up the number of maximal chains for (a), (b) and (c) we obtain

$$\begin{aligned} & (k+1)(k+2) + \frac{(k+1+1)!}{(k+1)!} + \frac{(k+1+1)!}{(k+1)!} \\ &= \frac{(k+1)!(k+1)(k+2) + (k+2)! + (k+2)!}{(k+1)!} \\ &= \frac{(k+1)![(k+1)(k+2) + (k+2) + (k+2)]}{(k+1)!} \\ &= (k+2)[k+1+1+1] \\ &= (k+2)(k+3). \quad \text{This establishes the result.} \end{aligned}$$

□

4.2.2 The group $Z_{p^n} + Z_{q^2} + Z_r$

Fixing the value of m to be $m = 2$ and advancing a few values of n we obtain the following table

n	$Z_{p^n} + Z_{q^2} + Z_r$	Number of Maximal Chains
1	$Z_p + Z_{q^2} + Z_r$	$12=2.3+3.3$
2	$Z_{p^2} + Z_{q^2} + Z_r$	$30=3.4+3.4+3.4$
3	$Z_{p^3} + Z_{q^2} + Z_r$	$60=4.5+5.6+3.5$
4	$Z_{p^4} + Z_{q^2} + Z_r$	$105=5.6+3.5.7+3.7$
.	.	.
.	.	.
.	.	.
k	$Z_{p^k} + Z_{q^2} + Z_r$	$(k+1)(k+2) + \frac{k(k+1)(k+2)}{2} + \frac{(k+1)(k+2)}{2} = \frac{(k+1)(k+2)(k+3)}{2}$

From the above observation we have lemma 4.2.3.

Lemma: 4.2.3

The number of maximal chains for the group $Z_{p^n} + Z_{q^2} + Z_r$ is

$$\frac{(n+1)(n+2)(n+3)}{2} = \frac{(n+2+1)!}{n!2!}.$$

Proof

Formula holds for $n = 1, 2, 3, 4$ as shown by the tree diagrams. We assume the formula

is true for $n = k$ that is $Z_{p^k} + Z_{q^2} + Z_r$ has $\frac{(k+1)(k+2)(k+3)}{2!}$ maximal chains.

We need to show that $Z_{p^{k+1}} + Z_{q^2} + Z_r$ has $\frac{(k+2)(k+3)(k+4)}{2!}$ maximal chains.

Now $Z_{p^{k+1}} + Z_{q^2} + Z_r$ has the following maximal subgroups

$$Z_{p^k} + Z_{q^2} + Z_r \quad (\text{a})$$

$$\mathbf{Z}_{p^{k+1}} + \mathbf{Z}_{q^2} + \{0\} \text{ (b)}$$

$$\mathbf{Z}_{p^{k+1}} + \mathbf{Z}_q + \mathbf{Z}_r \text{ (c)}$$

From assumption (a) $\mathbf{Z}_{p^k} + \mathbf{Z}_{q^2} + \mathbf{Z}_r$ has $\frac{(k+1)(k+2)(k+3)}{2!}$ maximal chains.

From Proposition 4.1.5 (b) $\mathbf{Z}_{p^{k+1}} + \mathbf{Z}_{q^2} + \{0\}$ has $\frac{(k+1+2)!}{2!(k+1)!}$ maximal chains. From

Proposition 4.1.7 we also know that (c) $\mathbf{Z}_{p^{k+1}} + \mathbf{Z}_q + \mathbf{Z}_r$ has $(k+2)(k+3)$ maximal chains.

Taking the sum of all the number of maximal chains obtained for (a),(b) and (c) we get

$$\begin{aligned} & \frac{(k+1)(k+2)(k+3)}{2!} + \frac{(k+1+2)!}{2!(k+1)!} + (k+2)(k+3) \\ &= \frac{(k+1)(k+2)(k+3)}{2!} + \frac{(k+3)(k+2)}{2} + \frac{2(k+2)(k+3)}{2} \\ &= \frac{(k+3)(k+2)[k+1+1+2]}{2} = \frac{(k+2)(k+3)(k+4)}{2} \text{ which establishes the} \end{aligned}$$

result. □

It can be easily noticed that if we continue in this fashion we will obtain the formulae of the number of maximal chains for the group $\mathbf{Z}_{p^n} + \mathbf{Z}_{q^m} + \mathbf{Z}_r$ for $m = 3, 4$ and these we list as lemmas without proof.

Lemma: 4.2.4

$G = \mathbf{Z}_{p^n} + \mathbf{Z}_{q^3} + \mathbf{Z}_r$ has $\frac{(n+1)(n+2)(n+3)(n+4)}{3!} = \frac{(n+3+1)!}{n!3!}$ maximal chains for $n \geq 1$.

Lemma: 4.2.5

$G = \mathbf{Z}_{p^n} + \mathbf{Z}_{q^4} + \mathbf{Z}_r$ has $\frac{(n+1)(n+2)(n+3)(n+4)(n+5)}{4!} = \frac{(n+4+1)!}{n!4!}$ maximal chains for all $n \geq 1$

In view of the lemmas 4.2.4 and 4.2.5 we can therefore give a general formula for the number of maximal chains for the group $Z_{p^n} \times Z_{q^m} \times Z_r$ which we state in the proposition to follow.

Proposition: 4.2.6

There are $\frac{(n+m+1)!}{n!m!}$ maximal chains for the group $G = Z_{p^n} + Z_{q^m} + Z_r$ where $m, n \in \mathbf{Z}^+$ and p, q and r are distinct primes.

Proof

We prove by inducting on the sum of the exponents of p, q , and r that is $n+m+1$.

Let $s = n+m+1$, the formula holds for $s=1$ because we have $n=m=0$ and this gives the group Z_r with one chain. The formula holds for $s=2$ since we either have $n=1, m=0$ or $n=0, m=1$ in which case we have essentially the two groups $Z_p + Z_r$

and $Z_q + Z_r$ respectively, and from proposition 4.1.7 these have $\frac{(1+1)!}{1!!} = 2$ and

$\frac{(1+0+1)!}{1!0!} = 2$ maximal chains respectively.

The formula holds for $s=3$ because we either $n=m=1$ which gives the group

$Z_p + Z_q + Z_r$ and by proposition 4.2.1, we have $(1+1)(1+2) = \frac{(1+1+1)!}{1!!} = 3! = 6$

maximal chains or secondly we may have $n=0, m=2$ or $n=2, m=0$ which essentially gives the groups $Z_{q^2} + Z_r$ and $Z_{p^2} + Z_r$ respectively, and from proposition

4.1.7 these each has $\frac{(2+1)!}{2!!} = 3$ and $\frac{(2+1+0)!}{2!!0!} = 3$ respectively. Now we assume

that the formula is true for $s=k \Rightarrow n+m+1=k \Rightarrow m=k-n-1$, that is

$Z_{p^n} + Z_{q^{k-n-1}} + Z_r$ has $\frac{k!}{n!(k-n-1)!}$ maximal chains. We need to show that

$Z_{p^n} + Z_{q^{k-n}} + Z_r$ has $\frac{(k+1)!}{n!(k-n)!}$ maximal chains. Now $Z_{p^n} + Z_{q^{k-n}} + Z_r$ has the

following maximal subgroups

$$Z_{p^{n-1}} + Z_{q^{k-n}} + Z_r \quad (\text{a})$$

$$\mathbf{Z}_{p^n} + \mathbf{Z}_{q^{k-n-1}} + \mathbf{Z}_r \quad (\text{b})$$

$$\mathbf{Z}_{p^n} + \mathbf{Z}_{q^{k-n}} + \{0\} \quad (\text{c})$$

In (a) $s = n - 1 + k - n + 1 = k$ therefore by assumption, $\mathbf{Z}_{p^{n-1}} + \mathbf{Z}_{q^{k-n}} + \mathbf{Z}_r$ has

$\frac{k!}{(n-1)!(k-n)!}$ maximal chains. In (b) $s = n + k - n - 1 + 1 = k$ therefore

$\mathbf{Z}_{p^n} + \mathbf{Z}_{q^{k-n-1}} + \mathbf{Z}_r$ has $\frac{k!}{n!(k-n-1)!}$ maximal chains by assumption. Finally

$\mathbf{Z}_{p^n} + \mathbf{Z}_{q^{k-n}} + \{0\}$ has $\frac{(n+k-n)!}{n!(k-n)!} = \frac{k!}{n!(k-n)!}$ maximal chains by Proposition 4.1.5

Summing up we obtain

$$\begin{aligned} & \frac{k!}{(n-1)!(k-n)!} + \frac{k!}{n!(k-n-1)!} + \frac{k!}{n!(k-n)!} \\ &= \frac{k!(n) + k!(k-n) + k!}{n!(k-n)!} = \frac{k![n+k-n+1]}{n!(k-n)!} = \frac{(k+1)!}{n!(k-n)!}. \end{aligned}$$

This completes the proof. □

Our discussion above enables us to conjecture on the general formula for the number of maximal chains for $\mathbf{Z}_{p^n} + \mathbf{Z}_{q^m} + \mathbf{Z}_{r^s}$ for p, q, r distinct primes and $n, m, s \in \mathbf{Z}^+$.

This is given as a proposition that follows.

Proposition: 4.2.7

There are $\frac{(n+m+s)!}{n!m!s!}$ maximal chains for the group $\mathbf{Z}_{p^n} + \mathbf{Z}_{q^m} + \mathbf{Z}_{r^s}$ for p, q, r

distinct primes and $n, m, s \in \mathbf{Z}^+$.

Proof

We prove by inducting on the sum of the powers of p, q and r that is $n + m + s$.

Let $j = n + m + s$, the formula holds for $j = 1$ because this implies that

$n = m = 0, s = 1$ so we have essentially the group \mathbf{Z}_r with one chain. The formula

holds for $j = 2$, that is we either have $n = 1, m = 0, s = 1$ or $n = 0, m = 1, s = 1$ and

$n = 1, m = 1, s = 0$ in which case we have the three groups $\mathbf{Z}_p + \mathbf{Z}_r, \mathbf{Z}_q + \mathbf{Z}_r$ and

$\mathbf{Z}_p + \mathbf{Z}_q$ respectively, and the result is true from proposition 4.1.7.

We assume that the formula holds for $j = k$, thus $j = n + m + s = k \Rightarrow m = k - n - s$

that is $Z_{p^n} + Z_{q^{k-n-s}} + Z_{r^s}$ has $\frac{k!}{n!(k-n-s)!s!}$ maximal chains. We need to show that

$Z_{p^n} + Z_{q^{k-n-s+1}} + Z_{r^s}$ has $\frac{(k+1)!}{n!(k-n-s+1)!s!}$ maximal chains. Now $Z_{p^n} + Z_{q^{k-n-s+1}} + Z_{r^s}$

has the following maximal subgroups,

$$Z_{p^{n-1}} + Z_{q^{k-n-s+1}} + Z_{r^s} \quad (\text{a})$$

$$Z_{p^n} + Z_{q^{k-n-s}} + Z_{r^s} \quad (\text{b})$$

$$Z_{p^n} + Z_{q^{k-n-s+1}} + Z_{r^{s-1}} \quad (\text{c})$$

In (a) $j = n - 1 + k - n - s + 1 + s = k$ therefore $Z_{p^{n-1}} + Z_{q^{k-n-s+1}} + Z_{r^s}$ has

$\frac{k!}{(n-1)!(k-n-s+1)!s!}$ maximal chains by assumption. In (b)

$j = n + k - n - s + s = k$ therefore $Z_{p^n} + Z_{q^{k-n-s}} + Z_{r^s}$ has $\frac{k!}{n!(k-n-s)!s!}$ maximal

chains. In (c) $j = n + k - n - s + 1 + s - 1 = k$ therefore $Z_{p^n} + Z_{q^{k-n-s+1}} + Z_{r^{s-1}}$ has

$\frac{k!}{n!(k-n-s+1)!(s-1)!}$ maximal chains.

Summing up all these we get

$$\begin{aligned} & \frac{k!}{(n-1)!(k-n-s+1)!s!} + \frac{k!}{n!(k-n-s)!s!} + \frac{k!}{n!(k-n-s+1)!(s-1)!} \\ &= \frac{k!(n) + k!(k-n-s+1) + k!(s)}{n!(k-n-s+1)!s!} = \frac{k![n+k-n-s+1+s]}{n!(k-n-s+1)!s!} = \frac{k!(k+1)}{n!(k-n-s+1)!s!} \\ &= \frac{(k+1)!}{n!(k-n-s+1)!s!}. \text{ This establishes the proof.} \quad \square \end{aligned}$$

Remark:

It can be shown that in the stage of establishing the induction in 4.2.6 if we

interchange the roles of n and m , we have that $Z_{p^{k-m}} + Z_{q^m} + Z_r$ has $\frac{(k+1)!}{m!(k-m)!}$

while $Z_{p^n} + Z_{q^{k-n}} + Z_r$ has $\frac{(k+1)!}{n!(k-n)!}$ maximal chains. It can be shown that

$\frac{(k+1)!}{m!(k-m)!} = \frac{(k+1)!}{n!(k-n)!}$. Similarly with 4.1.13 $Z_{p^n} + Z_{q^{k-n-s}} + Z_{r^s}$ has $\frac{k!}{n!(k-n-s)!s!}$

maximal chains and $Z_{p^{k-m-1}} + Z_{q^m} + Z_{r^s}$ will have $\frac{k!}{m!(k-m-s)!s!}$ maximal chains.

From the above observation we can generalize the formula of the number of maximal chains for the group $G = Z_{p_1^{n_1}} + Z_{p_2^{n_2}} + \dots + Z_{p_k^{n_k}}$. This we give as a proposition that follows below.

Proposition: 4.2.8

The group $G = Z_{p_1^{n_1}} + Z_{p_2^{n_2}} + \dots + Z_{p_m^{n_m}}$

has $\frac{(n_1 + n_2 + n_3 + \dots + n_m)!}{n_1!n_2!n_3!\dots n_m!} = \frac{\left(\sum_{i=1}^m n_i!\right)}{n_1!n_2!n_3!\dots n_m!}$ maximal chains, where p_i

$1 \leq i \leq m$ are distinct primes.

Proof

We prove by inducting on $n_1 + n_2 + n_3 + \dots + n_m = s$. Let $s = 1$ then we have either

$G = Z_{p_1^{n_1}}$ or $G = Z_{p_2^{n_2}}$ or $G = Z_{p_3^{n_3}}$ or ... or $G = Z_{p_m^{n_m}}$ which has $\frac{(n_1)!}{(n_1)!} = 1$ or

$\frac{(n_2)!}{(n_2)!} = 1$ or $\frac{(n_3)!}{(n_3)!} = 1$ or ... or $\frac{(n_m)!}{(n_m)!} = 1$ maximal chains respectively.

Now we assume the formula is true for

$s = k = n_1 + n_2 + \dots + n_m \Rightarrow n_1 = k - n_2 - n_3 - \dots - n_m$ that is

$G = Z_{p_1^{k-n_2-n_3-\dots-n_m}} + Z_{p_2^{n_2}} + \dots + Z_{p_m^{n_m}}$ has

$\frac{((k - n_2 - n_3 - \dots - n_m) + n_2 + n_3 + \dots + n_m)!}{(k - n_2 - n_3 - \dots - n_m)!n_2!n_3!\dots n_m!} = \frac{k!}{(k - n_2 - n_3 - \dots - n_m)!n_2!n_3!\dots n_m!}$

maximal chains.

We need to show that the formula holds for $s = k + 1 = n_1 + n_2 + \dots + n_m$, that is

$G = Z_{p_1^{k-n_2-n_3-\dots-n_m+1}} + Z_{p_2^{n_2}} + \dots + Z_{p_m^{n_m}}$ has

$$\frac{((k - n_2 - n_3 - \dots - n_m) + n_2 + n_3 + \dots + n_m)!}{(k - n_2 - n_3 - \dots - n_m + 1)!n_2!n_3!\dots n_m!} = \frac{(k + 1)!}{(k - n_2 - n_3 - \dots - n_m + 1)!n_2!n_3!\dots n_m!}$$

maximal chains. We observe that $G = \mathbf{Z}_{p_1^{k-n_2-n_3-\dots-n_m+1}} + \mathbf{Z}_{p_2^{n_2}} + \mathbf{Z}_{p_3^{n_3}} + \dots + \mathbf{Z}_{p_m^{n_m}}$ has the following maximal subgroups,

$$(1) \mathbf{Z}_{p_1^{k-n_2-n_3-\dots-n_m}} + \mathbf{Z}_{p_2^{n_2}} + \mathbf{Z}_{p_3^{n_3}} + \dots + \mathbf{Z}_{p_m^{n_m}}$$

$$(2) \mathbf{Z}_{p_1^{k-n_2-n_3-\dots-n_m+1}} + \mathbf{Z}_{p_2^{n_2-1}} + \mathbf{Z}_{p_3^{n_3}} + \dots + \mathbf{Z}_{p_m^{n_m}}$$

$$(3) \mathbf{Z}_{p_1^{k-n_2-n_3-\dots-n_m+1}} + \mathbf{Z}_{p_2^{n_2}} + \mathbf{Z}_{p_3^{n_3-1}} + \dots + \mathbf{Z}_{p_m^{n_m}}$$

·

·

·

$$(m-1) \mathbf{Z}_{p_1^{k-n_2-n_3-\dots-n_m+1}} + \mathbf{Z}_{p_2^{n_2}} + \mathbf{Z}_{p_3^{n_3-1}} + \dots + \mathbf{Z}_{p_{m-1}^{n_{m-1}-1}} + \mathbf{Z}_{p_m^{n_m}}$$

$$(m) \mathbf{Z}_{p_1^{k-n_2-n_3-\dots-n_m+1}} + \mathbf{Z}_{p_2^{n_2}} + \mathbf{Z}_{p_3^{n_3-1}} + \dots + \mathbf{Z}_{p_{m-1}^{n_{m-1}}} + \mathbf{Z}_{p_m^{n_m-1}}$$

Now by assumption each maximal subgroup has the following maximal chains:

(1) has:

$$\frac{((k - n_2 - n_3 - \dots - n_m) + n_2 + n_3 + \dots + n_m)!}{(k - n_2 - n_3 - \dots - n_m)!n_2!n_3!\dots n_m!} = \frac{k!}{(k - n_2 - n_3 - \dots - n_m)!n_2!n_3!\dots n_m!}$$

(2) has:

$$\frac{((k - n_2 - \dots - n_m + 1) + (n_2 - 1) + n_3 + \dots + n_m)!}{(k - n_2 - \dots - n_m + 1)!(n_2 - 1)!n_3!\dots n_m!} = \frac{k!}{(k - n_2 - \dots - n_m + 1)!(n_2 - 1)!n_3!\dots n_m!}$$

(3) has:

$$\frac{((k - n_2 - \dots - n_m + 1) + n_2 + (n_3 - 1) + \dots + n_m)!}{(k - n_2 - \dots - n_m + 1)!n_2!(n_3 - 1)!\dots n_m!} = \frac{k!}{(k - n_2 - \dots - n_m + 1)!n_2!(n_3 - 1)!\dots n_m!}$$

·

·

(m-1) has:

$$\frac{((k - n_2 - \dots - n_m + 1) + n_2 + \dots + (n_{m-1} - 1) + n_m)!}{(k - n_2 - \dots - n_m + 1)!n_2!\dots(n_{m-1} - 1)!n_m!} = \frac{k!}{(k - n_2 - \dots - n_m + 1)!n_2!\dots(n_{m-1} - 1)!n_m!}$$

(m) has:

$$\frac{((k - n_2 - \dots - n_m + 1) + n_2 + n_3 + \dots + (n_m - 1))!}{(k - n_2 - \dots - n_m + 1)!n_2!n_3!\dots(n_m - 1)!} = \frac{k!}{(k - n_2 - \dots - n_m + 1)!n_2!n_3!\dots(n_m - 1)!}$$

Summing all of these we obtain

$$\frac{k!}{(k - n_2 - n_3 - \dots - n_m)!n_2!\dots n_m!} + \frac{k!}{(k - n_2 - n_3 - \dots - n_m + 1)!(n_2 - 1)!\dots n_m!}$$

$$+ \frac{k!}{(k - n_2 - n_3 - \dots - n_m + 1)!n_2!(n_3 - 1)!\dots n_m!} + \dots$$

$$+ \frac{k!}{(k - n_2 - n_3 - \dots - n_m + 1)!n_2!\dots(n_{m-1} - 1)!n_m!} +$$

$$\frac{k!}{(k - n_2 - n_3 - \dots - n_m + 1)!n_2!\dots n_{m-1}!(n_m - 1)!}$$

$$= \frac{k!(k - n_2 - n_3 - \dots - n_m + 1) + k!(n_2) + \dots k!(n_m)}{(k - n_2 - n_3 - \dots - n_m + 1)!n_2!\dots n_{m-1}!n_m!}$$

$$= \frac{k!(k - n_2 - n_3 - \dots - n_m + 1 + n_2 + n_3 + \dots + n_m)}{(k - n_2 - n_3 - \dots - n_m + 1)!n_2!n_3!\dots n_m!}$$

$$= \frac{k!(k + 1)}{(k - n_2 - n_3 - \dots - n_m + 1)!n_2!n_3!\dots n_m!}$$

$$= \frac{(k + 1)!}{(k - n_2 - n_3 - \dots - n_m + 1)!n_2!\dots n_{m-1}!n_m!}; \text{ which establishes the result. } \quad \square$$

Chapter Five

ON THE NUMBER OF EQUIVALENCE CLASSES OF FUZZY SUBGROUPS

FOR THE GROUPS $G = \mathbb{Z}_{p^n} + \mathbb{Z}_{q^m}$ AND $G = \mathbb{Z}_{p^n} + \mathbb{Z}_{q^m} + \mathbb{Z}_{r^s}$

5.0 Introduction

[20], [25],[26], [26],[27], [28],[29]and [30] were very useful in the compilation of this background information on the notions of keychains, pins (already mentioned in chapter 3), pinned-flag (for more see Murali and Makamba[25],[26] and [27]) and pin extension which we exploit in the computation of the number of equivalence classes of fuzzy subgroups for these selected groups. A detailed explanation to justify the method of computing the number of fuzzy subgroups using maximal chains is given in section 5.2.0. We also give specific examples to illustrate how the counting technique is applied.

In 5.1.3.1 we include some work by Ngcibi [30] on the formulae for the number of distinct fuzzy subgroups for the group $G = \mathbb{Z}_{p^n} \times \mathbb{Z}_{q^m}$ where p, q are distinct primes and $m = 1, 2, 3$. With the aid of a few combinatorial analysis definitions (for more see Riordan[36]), we give a proof of Ngcibi's Theorem 5.3.3 in [30] which the author did not prove. This we do as another illustration for the justification of our counting technique.

5.1 Keychains and Pin-extensions

Definition: 5.1.0

A set of real numbers on $I = [0,1]$ of the form $1 > \lambda_1 > \lambda_2 > \dots > \lambda_{n-2} > \lambda_{n-1} > \lambda_n$ where λ_n may or may not be zero, is called a finite n -chain. This chain is customarily written in descending order as follows $1\lambda_1\lambda_2\dots\lambda_{n-1}\lambda_n$. 6.1.0..a

The real numbers $1, \lambda_1, \lambda_2, \dots, \lambda_{n-1}, \lambda_n$ are called pins. The finite n -chain becomes a keychain if $1 \geq \lambda_1 \geq \lambda_2 \geq \dots \geq \lambda_{n-2} \geq \lambda_{n-1} \geq \lambda_n \geq 0$.

An increasing maximal chain of $n+1$ subgroups of G starting with the trivial subgroup $\{0\}$ is called a flag on G .

Definition: 5.1.1

A pinned-flag is the pair $\{\zeta, \ell\}$ where ζ is the flag on G and ℓ is a keychain.

We customarily write this to suit fuzzy subgroups with $G = G_n$ as follows

$$0^1 \subset G_1^{\lambda_1} \subset G_2^{\lambda_2} \subset \dots \subset G_{n-1}^{\lambda_{n-1}} \subset G_n^{\lambda_n}$$

Associated to the keychain 6.1.0.a with the λ_i 's not all necessarily different, a fuzzy subgroup μ on G can be constructed that corresponds to the pinned –flag on G as follows

$$\mu(x) = \begin{cases} 1 & \text{if } x = 0 \\ \lambda_1 & \text{if } x \in G_1 \setminus \{0\} \\ \lambda_2 & \text{if } x \in G_2 \setminus G_1 \\ \cdot & \cdot \\ \cdot & \cdot \\ \cdot & \cdot \\ \lambda_n & \text{if } x \in G_n \setminus G_{n-1} \end{cases}$$

where G_n is the whole group G . μ defined above is a fuzzy subgroup of G .

Theorem: 5.1.2

Let G be a finite group. A fuzzy subset μ of G is a fuzzy subgroup of G if there exists a maximal chain of subgroups $G_0 < G_1 < \dots < G_n = G$ such that for the numbers

$\lambda_0, \lambda_1, \dots, \lambda_n$ belonging to $\text{Im } \mu$ with $\lambda_0 > \lambda_1 > \dots > \lambda_n$ we have $\mu(G_0) = \lambda_0$,

$\mu(G'_1) = \lambda_1, \dots, \mu(G'_n) = \lambda_n$, where $G'_i = G_i \setminus G_{i-1}, 1 \leq i \leq n$

Conversely, any fuzzy subgroup of G satisfies such condition.

Proof ([6])

Where a fuzzy subgroup has been represented by a pinned –flag say

for example

$$(O)^1 \subset (O \times O \times Z_r)^\lambda \subset (Z_p \times O \times Z_r)^\beta \subset (Z_p \times O \times Z_{r^2})^\gamma \subset (Z_{p^2} \times O \times Z_{r^2})^\vartheta$$

pin-extension can be carried out on this and one such extension is given by

$$(O)^1 \subset (O \times O \times Z_r)^\lambda \subset (Z_p \times O \times Z_r)^\beta \subset (Z_p \times O \times Z_{r^2})^\gamma \subset (Z_{p^2} \times O \times Z_{r^2})^\vartheta \\ \subset (Z_{p^2} \times Z_q \times Z_{r^2})^\xi \text{ where } \vartheta = \xi \text{ or } 0 < \vartheta < \xi \text{ or } \xi = 0.$$

Definition: 5.1.3

An extension of $O \subset G_1 \subset G_2 \subset \dots \subset G_n$ is a maximal chain

$O \subset G_1 \subset G_2 \subset \dots \subset G_n \subset G_{n+1}$ having the chain

$O \subset G_1 \subset G_2 \subset \dots \subset G_n$ as a subchain.

Since we identify a fuzzy subgroup μ with its keychain when the underlying maximal chain is known, an extension of a maximal chain also results in a new keychain associated with that chain. Below we want to briefly explain how we carry out this pin-extension principle.

For a fixed maximal chain with two components we have seen that there are three distinct fuzzy subgroups which can be represented using the following tree diagram:

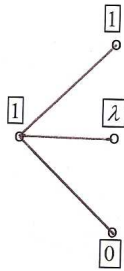

Now when extending in the diagram above, to the pin 1 we may attach a 1, λ or 0 with $1 > \lambda > 0$, to the pin λ we may attach a λ , β or 0 with $1 > \lambda > \beta > 0$. We get seven distinct equivalence classes of fuzzy subgroups as shown in the next tree diagram.

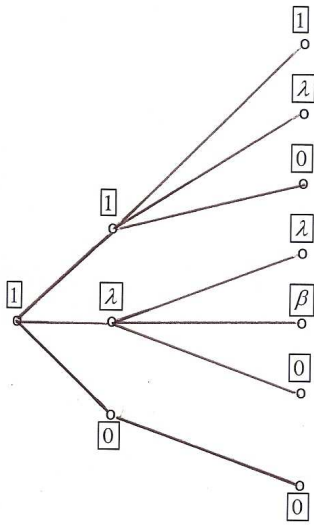

In the tree diagram above if we attach a branch of the form

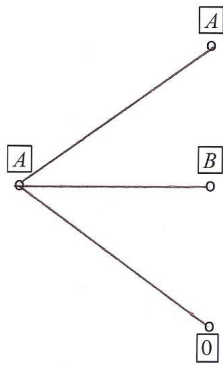

where $A = 1, \lambda$ or β and $B = \lambda, \beta$ or $\gamma \neq 0$, to a zero we attach a zero, we obtain fifteen distinct fuzzy subgroups.

So in general if we have a fixed maximal chain of subgroups $O \subset G_1 \subset G_2 \subset \dots \subset G_n = G$, a keychain associated with chain is of the form $1\alpha_1\alpha_2\dots\alpha_n$ for $1 > \alpha_1 > \alpha_2 > \dots > \alpha_n \geq 0$. If we extend to $O \subset G_1 \subset G_2 \subset \dots \subset G_n \subset G_{n+1} = G$, the keychain $1\alpha_1\alpha_2\dots\alpha_n$ for $\alpha_n \neq 0$ can only extend to $1\alpha_1\alpha_2\dots\alpha_n\alpha_n$ or $1\alpha_1\alpha_2\dots\alpha_n\alpha_{n+1}$ or $1\alpha_1\alpha_2\dots\alpha_n 0$. If $\alpha_n = 0$, we can only attach a zero.

5.2 0 Justification of the Counting technique of Fuzzy Subgroups

Our goal is to make use of this pin-extension principle and the counting technique introduced earlier to establish a formula for the number of equivalence classes of fuzzy subgroups for the groups $Z_{p^n} + Z_q + Z_r$, $Z_{p^n} + Z_{q^m} + Z_r$ and $Z_{p^n} + Z_q + Z_{r^s}$ and possibly establish the general formula for the group $Z_{p^n} + Z_{q^m} + Z_{r^s}$ for distinct primes p, q and r , $n, m, s \in \mathbb{Z}^+$.

To achieve this we first give a detailed explanation on the counting technique of distinct equivalence classes of fuzzy subgroups. Again maximal chains of the group play a pivotal role.

Let $O \subset G_1 \subset G_2 \subset \dots \subset G_n = G$ be a maximal chain of G . The number of equivalence classes of fuzzy subgroups of G can be computed by considering how many each maximal chain contributes in any sequence.

Suppose we start with a maximal chain $O \subset G_1 \subset G_2 \subset \dots \subset G_n = G$ (a). There are $2^{n+1} - 1$ distinct equivalence classes of fuzzy subgroups contributed by this chain [9].

Now if another maximal chain is considered say $O \subset J_1 \subset J_2 \subset \dots \subset J_n = G$ (b) where only one $J_i \neq G_i$ for some $i \in \{1, 2, 3, \dots, n\}$ the number contributed by this chain excluding those counted in chain (a) is given by this proposition.

Proposition: 5.2.1

The number of fuzzy subgroups of G obtained from (b) only excluding those obtained from (a) is $\frac{2^{n+1}}{2}$ for $n \geq 2$.

Proof

We prove by inducting on n . For $n = 2$ we have the following maximal chains

$$O \subset G_1 \subset G_2 = G \quad (1)$$

$$O \subset J_1 \subset J_2 = G \quad (2)$$

From previous result (1) contributes $2^{2+1} - 1 = 7$ distinct fuzzy subgroups as follows. Since there are three levels such distinct fuzzy subgroups can be represented by the keychains $111 \quad 11\lambda \quad 110 \quad 1\lambda\lambda \quad 1\lambda\beta \quad 1\lambda 0 \quad 100$ where $1 > \lambda > \beta > 0$. The keychains

111 $1\lambda\lambda$ 100 cannot be counted again in (2) as they would represent precisely the same fuzzy subgroups counted using (1)

To illustrate this we observe that for instance 111 is $\mu(x) = \begin{cases} 1, x = 0 \\ \lambda, otherwise \end{cases}$

This shows that G_1 and J_1 play no role in the determination of μ .

So if these keychains are removed we remain with four. This is the number contributed by (2) distinct from those of (1).

On the other hand $1\lambda\beta$ is distinct in (2) from the one counted in (1) because

in (1) $1\lambda\beta$ is $\mu(x) = \begin{cases} 1, x = 0 \\ \lambda, x \in G_1 \setminus \{0\} \\ \beta, x \in G \setminus G_1 \end{cases}$ while in (2) is $\nu(x) = \begin{cases} 1, x = 0 \\ \lambda, x \in J_1 \setminus \{0\} \\ \beta, x \in G \setminus J_1 \end{cases}$

Now there exist $x \in G_1 \setminus J_1$. Since chain (1) \neq (2) then $J_1 \neq G_1$. So for this x

$\mu(x) = \lambda$ while $\nu(x) = \beta \neq \lambda \Rightarrow \mu \neq \nu$. Thus (2) contributes $4 = 2^2 = \frac{2^{2+1}}{2}$ fuzzy

subgroups. So the proposition is true for $n = 2$.

Now we assume the proposition is true for $n = k > 2$ that is (1) contributes $2^{k+1} - 1$

and (2) contributes $\frac{2^{k+1}}{2} = 2^k$ distinct fuzzy subgroups not counted in (1).

Let $n = k + 1$ and let $1\lambda_1\lambda_2\dots\lambda_k$ be a keychain of (2) in the case when $n = k > 2$.

We consider two cases:

Case $\lambda_k \neq 0$: Extending this keychain to a keychain in the case $n = k + 1$, we have the following possibilities $1\lambda_1\lambda_2\dots\lambda_k\lambda_k, 1\lambda_1\lambda_2\dots\lambda_k\lambda_{k+1}, 1\lambda_1\lambda_2\dots\lambda_k 0$.

Case $\lambda_k = 0$: There is only one way of extending to the case $n = k + 1$ and that is to attach a zero, that is $1\lambda_1\lambda_2\dots 00$. The two cases give four keychains for $n = k + 1$ from

the one keychain for $n = k > 2$. Now there are $\frac{1}{2} \left[\frac{2^{k+1}}{2} \right] = \frac{2^k}{2}$ keychains of (2) for

$n = k > 2$ ending with $\lambda_k \neq 0$ and the rest are keychains ending with $\lambda_k = 0$.

Thus (2) for $n = k + 1$ contributes $3 \times \frac{2^k}{2} + 1 \times \frac{2^k}{2} = 4 \times \frac{2^k}{2} = 2^{k+1} = \frac{2^{k+2}}{2}$ distinct

fuzzy subgroups not counted in (1). This completes the proof. \square

Example: 5.2.1.1

On the number of fuzzy subgroups of $G = \mathbf{Z}_p + \mathbf{Z}_q$. This group has the following maximal chains $\{0\} \subset \mathbf{Z}_p + \{0\} \subset \mathbf{Z}_p + \mathbf{Z}_q = G$ (i)

$$\{0\} \subset \{0\} + \mathbf{Z}_q \subset \mathbf{Z}_p + \mathbf{Z}_q = G \text{ (ii)}$$

Here (i) contributes $2^3 - 1 = 7$ distinct fuzzy subgroups. Since there are three levels, fuzzy subgroups here are represented by the following keychains $111 \ 11\lambda \ 110 \ 1\lambda\lambda \ 1\lambda\beta \ 1\lambda 0 \ 100$ where $1 > \lambda > \beta > 0$. The keychains $111 \ 1\lambda\lambda \ 100$ cannot be counted again in (ii) as they would represent precisely the same fuzzy subgroups counted using (i). So we remain with four which are the fuzzy subgroups contributed by (ii).

These are distinct from those counted in (i) for the following reasons: $1\lambda\beta$ in (i) is

$$\mu(x) = \begin{cases} 1, x = 0 \\ \lambda, x \in \mathbf{Z}_p + \{0\} \setminus \{0\} \\ \beta, x \in G \setminus \mathbf{Z}_p + \{0\} \end{cases} \text{ while in (ii) it is } \nu(x) = \begin{cases} 1, x = 0 \\ \lambda, x \in \{0\} + \mathbf{Z}_q \setminus \{0\} \\ \beta, x \in G \setminus \{0\} + \mathbf{Z}_q \end{cases}. \text{ It is clear}$$

that $\{0\} + \mathbf{Z}_q \neq \mathbf{Z}_p + \{0\}$ therefore there exists $x \in \{0\} + \mathbf{Z}_q \setminus \mathbf{Z}_p + \{0\} \Rightarrow \mu \neq \nu$. For

such an $x \ \nu(x) = \lambda$ and $\mu(x) = \beta \neq \lambda$. Therefore the number of fuzzy subgroups

contributed by (ii) distinct from those of (i) is $4 = \frac{1}{2}[2^3]$. The total number of distinct

fuzzy subgroups for the group is $7 + 4 = 11$.

Note: From now on we assume each chain (2) yields $\frac{2^{n+1}}{2}$ fuzzy subgroups even if (2)

has two or more subgroups distinct from those of (1).

Proposition: 5.2.2

Suppose G has the following maximal chains $O \subset G_1 \subset G_2 \subset \dots \subset G_n = G$ (a)

$O \subset J_1 \subset J_2 \subset \dots \subset J_n = G$ (b) and a third maximal chain

$O \subset K_1 \subset K_2 \subset \dots \subset K_n = G$ (c) distinct from (a) and (b), and suppose $\exists i \in \mathbb{N}$ such

that $J_i \neq G_i$, $K_i \neq J_i$ and $K_i \neq G_i$, then when computing the number of fuzzy

subgroups of G , the number contributed by (b) is equal to the number of fuzzy

subgroups contributed by (c) for $n \geq 2$.

Proof

We prove by inducting on n . If $n = 2$ we have the following maximal chains

$$O \subset G_1 \subset G_2 = G \quad (\text{i})$$

$$O \subset J_1 \subset J_2 = G \quad (\text{ii})$$

$$O \subset K_1 \subset K_2 = G \quad (\text{iii}) \text{ with } G_1 \neq J_1 \neq K_1. \text{ Clearly } K_1 \neq G_1.$$

By proposition 5.2.1 chain (i) has $2^3 - 1$ fuzzy subgroups. (ii) has $\frac{2^3}{2} = 2^2$ fuzzy subgroups distinct from those counted in (i).

Similarly as in proposition 5.2.1 the fuzzy subgroups of (i) can be represented by the keychains $111 \quad 11\lambda \quad 110 \quad 1\lambda\lambda \quad 1\lambda\beta \quad 1\lambda 0 \quad 100$ where $1 > \lambda > \beta > 0$. It is clear that the keychains $111 \quad 1\lambda\lambda \quad 100$ represent the same fuzzy subgroups in all the three maximal chains thus they are not included in chain (iii). The remaining keychains are $11\lambda \quad 110 \quad 1\lambda\beta \quad 1\lambda 0$.

Since $G_1 \neq J_1 \neq K_1$ and $K_1 \neq G_1$, these four keychains will represent distinct fuzzy subgroups in all the three maximal chains. Therefore chain (iii) has four fuzzy subgroups not counted in maximal chains (i) and (ii). Thus the number of fuzzy subgroups contributed by (iii) is equal to the number of fuzzy subgroups contributed by (ii) for $n = 2$.

Now we assume the proposition is true for $n = k > 2$. If we consider a keychain $1\lambda_1\lambda_2\dots\lambda_k$ of the maximal chain (ii) for $n = k > 2$ and extending it to the case when $n = k + 1$ as in proposition 5.2.1 we obtain the number of fuzzy subgroups

contributed by maximal chain (ii) to be $4 \times \frac{2^k}{2} = 2^{k+1}$. This number is equal to the

number of fuzzy subgroups contributed by maximal chain (iii) because the number of fuzzy subgroups contributed by maximal chain (iii) for $n = k > 2$ is the same as that contributed by maximal chain (ii) for $n = k > 2$. This completes the proof. \square

Proposition: 5.2.3

In the process of computing the number of fuzzy subgroups using maximal chains suppose there are three maximal chains as follows

$$O \subset G_1 \subset G_2 \subset \dots \subset G_n = G \quad (\text{a})$$

$$O \subset K_1 \subset K_2 \subset \dots \subset K_n = G \quad (\text{b})$$

$$O \subset J_1 \subset J_2 \subset \dots \subset J_n = G \quad (\text{c}) \text{ taken strictly in the given sequence.}$$

Suppose there exists $i, j \in \mathbb{N}, i \neq j$ such that $G_i \neq J_i, K_i = G_i, K_j \neq G_j$ and $K_j \neq J_j$.

Then the number of fuzzy subgroups for the maximal chain (b) is equal to the number of fuzzy subgroups for the maximal chain (c) for $n \geq 3$.

Proof

We prove by inducting on n . Let $n = 3$ and consider the following maximal chains

$$O \subset G_1 \subset G_2 \subset G_3 = G \quad (\text{a}')$$

$$O \subset K_1 \subset K_2 = G_2 \subset K_3 = G \quad (\text{b}')$$

$$O \subset J_1 \subset J_2 \subset J_3 = G \quad (\text{c}') \text{ with } K_1 \neq G_1, K_1 \neq J_1, J_2 \neq G_2 \Rightarrow K_2 \neq J_2.$$

(a') contributes $2^4 - 1$ distinct fuzzy subgroups. We list them as keychains

$$1111 \quad 11\lambda 0 \quad 1\lambda\beta\beta$$

$$111\lambda \quad 1100 \quad 1\lambda\beta\sigma$$

$$1110 \quad 1\lambda\lambda\lambda \quad 1\lambda\beta 0$$

$$11\lambda\lambda \quad 1\lambda\lambda\beta \quad 1\lambda 00$$

$$11\lambda\beta \quad 1\lambda\lambda 0 \quad 1000$$

By proposition 5.2.1 (b') has $\frac{2^4}{2} = 8$ distinct fuzzy subgroups.

Since $K_2 = G_2$, the keychains 1111 111 λ 1110 1 $\lambda\lambda\lambda$ 1 $\lambda\lambda\beta$ 1 $\lambda\lambda 0$ and 1000

represent the same fuzzy subgroups in both (a') and (b'). Thus to find keychains of (c') not counted in (a') we look at those listed for (b').

Since $K_1 \neq J_1$, the keychains of (b') represent different fuzzy subgroups in (c'). For

example 11 $\lambda\lambda$ is $\mu(x) = \begin{cases} 1, x \in J_1 \\ \lambda, x \in G \setminus J_1 \end{cases}$ in (c') while in (b') the same keychain is

$$\nu(x) = \begin{cases} 1, x \in K_1 \\ \lambda, x \in G \setminus K_1 \end{cases}. \text{ Since } J_1 \neq K_1, \mu \neq \nu.$$

Case $G_1 \neq J_1$

The keychains 11 $\lambda\lambda$ 11 $\lambda\beta$ 11 $\lambda 0$ 1100 1 $\lambda\beta\beta$ 1 $\lambda\beta\sigma$ 1 $\lambda\beta 0$ 1 $\lambda 00$ on (c') represent fuzzy subgroups that have not appeared before since $K_2 \neq J_2, G_2 \neq J_2$ and $K_1 \neq J_1$.

All other keychains not listed here represent fuzzy subgroups that have been counted

elsewhere. Thus (c') contributes precisely $8 = \frac{2^4}{2}$ fuzzy subgroups.

Case $J_1 = G_1$

The seven keychains 1111, $1\lambda\lambda\lambda$, 1000, $11\lambda\lambda$, 1100, $1\lambda\beta\beta$ and $1\lambda 00$ of (c') represent the same fuzzy subgroups in (a') since $J_1 = G_1$. This leaves us with the keychains 111λ , 1110, $11\lambda\beta$, $11\lambda 0$, $1\lambda\lambda\beta$, $1\lambda\lambda 0$, $1\lambda\beta\sigma$ and $1\lambda\beta 0$ which represent fuzzy subgroups of (c') that have not appeared in (a') or (b').

Thus (c') contributes eight distinct fuzzy subgroups. Now assume the proposition is true for $n = k > 3$. Extending the keychains to the case $n = k + 1$ as in propositions 5.2.1 and 5.2.2 yields the required results. \square

Example: 5.2.3.1

$G = \mathbf{Z}_{p^2} + \mathbf{Z}_q$ has the following maximal chains,

$$\{0\} \subset \mathbf{Z}_p + \{0\} \subset \mathbf{Z}_p + \mathbf{Z}_q \subset \mathbf{Z}_{p^2} + \mathbf{Z}_q$$

$$\{0\} \subset \{0\} + \mathbf{Z}_q \subset \mathbf{Z}_p + \mathbf{Z}_q \subset \mathbf{Z}_{p^2} + \mathbf{Z}_q$$

$$\{0\} \subset \mathbf{Z}_p + \{0\} \subset \mathbf{Z}_{p^2} + \{0\} \subset \mathbf{Z}_{p^2} + \mathbf{Z}_q$$

All the maximal chains are distinct. The first chain yields $2^4 - 1$ fuzzy subgroups while the last two each yields $\frac{1}{2}[2^4] = 2^3$ fuzzy subgroups by Proposition 5.2.3. The total number for the group is $2^4 - 1 + 2(2^3) = 31$ fuzzy subgroups.

Proposition: 5.2.4

In the process of counting distinct fuzzy subgroups, let the first maximal chain have $2^{n+1} - 1$ fuzzy subgroups. A chain (k) in the process which has precisely one subgroup J that has not appeared in the previous maximal chain

(i), for $i = 1, 2, 3, \dots, k - 1$, contributes $\frac{2^{n+1}}{2}$ distinct fuzzy subgroups not counted in

the chains (i), for $n \geq 3$.

Proof. This is essentially Proposition 5.2.2.

Note:

In the process of computing the number of distinct fuzzy subgroups, we start with any maximal chain (1). This chain is assigned $2^{n+1} - 1$ fuzzy subgroups. Any second maximal chain (2) is assigned $\frac{2^{n+1}}{2}$ fuzzy subgroups. Clearly (2) has at least one

subgroup not appearing in (1). If a maximal chain (3) has at least one subgroup H of G not appearing in (1) or (2), then the number of fuzzy subgroups contributed by (3) is equal to that contributed by (2) when computed in a particular sequence. Now suppose the two subgroups of (2) H and K do not appear in (1). Then H may be assigned to (3) as new and K is assigned to (2) as new. We will also say H and K are distinguishing factors of (3) and (2) respectively. In the first chain (1) all subgroups are distinguishing factors. This process ensures that each chain other than (1) is assigned $\frac{2^{n+1}}{2^m}$ (for $m < n + 1$) fuzzy subgroups even if it has one or more subgroups

distinct from those of (1). In this case we simply say (1) contributes $\frac{2^{n+1}}{2^m}$ fuzzy subgroups. Thus the ordering of flags becomes irrelevant. \square

We may rephrase Proposition 5.2.4 as follows:

Proposition: 5.2.5

In the process of counting distinct fuzzy subgroups, let the first maximal chain have $2^{n+1} - 1$ fuzzy subgroups. Suppose chain (i) has a distinguishing factor, then the number of fuzzy subgroups of maximal chain (i) , $i \neq 1$ is equal to $\frac{2^{n+1}}{2}$ for $n \geq 3$.

Proposition: 5.2.6

In the process of counting fuzzy subgroups, let (k) be the maximal chain $O \subset K_1 \subset K_2 \subset \dots \subset K_n = G$ such that all the K_i 's have appeared in some previous maximal chain (i) for $i = 1, 2, \dots, k$ and have been used as distinguishing factors.

Then the number of fuzzy subgroups of (k) is equal to $\frac{2^{n+1}}{2^2}$ for $n \geq 3$.

Proof

We induct on n . Let $n = 3$, then we have (k) being $O - K_1 - K_2 - K_3 = G$.

Assume without loss of generality the following maximal chains of G

$$O \subset G_1 \subset G_2 \subset G_3 = G \quad (a)$$

$$O \subset J_1 \subset J_2 \subset J_3 = G \quad (b)$$

$$O \subset L_1 \subset L_2 \subset L_3 = G \quad (c)$$

and (k) as above such that $J_1 = G_1, J_2 \neq G_2, K_1 = L_1 \neq J_1, L_1 \neq G_1, K_2 = J_2$, and $L_2 = G_2$.

(b) contributes $\frac{2^4}{2} = 8$ keychains as follows $1\lambda\lambda\beta \ 1\lambda\lambda 0 \ 111\lambda \ 1110$

$$11\lambda\beta \ 1\lambda\beta\sigma \ 1\lambda\beta 0 \ 11\lambda 0$$

Since $K_2 = J_2$, the keychains $1\lambda\lambda\beta \ 1\lambda\lambda 0 \ 111\lambda \ 1110$ of (b) represent precisely the same fuzzy subgroups as in the maximal chain (k). We therefore do not count these fuzzy subgroups in (k).

It is also clear that $1111 \ 1\lambda\lambda\lambda$ and 1000 cannot be counted in (k).

This leaves us with eight keychains that is $11\lambda\beta$ $11\lambda 0$ $1\lambda\beta\sigma$ $1\lambda\beta 0$ from (b) and $11\lambda\lambda$ 1100 $1\lambda\beta\beta$ $1\lambda 00$ from (a).

But since $K_1 = L_1$ the keychains $11\lambda\lambda$ 1100 $1\lambda\beta\beta$ $1\lambda 00$ have been counted in (c).

Thus (k) has only four fuzzy subgroups not counted in (a) ,(b) and (c), and $4 = \frac{2^{3+1}}{2^2}$.

Note: The least number of distinct fuzzy subgroups a chain can have is four.

So the proposition is true for $n = 3$.

Now we assume the proposition is true for $n = k > 3$ and then use extensions of keychains to show that it is true for $n = k + 1$. This completes the proof. \square

Remark: The arguments of Propositions 5.2.5 and 5.2.6 can be continued inductively. In fact if there is no distinguishing factor (new subgroup) in a maximal chain (i) but there is a new pair or a distinguishing pair (not used in the $i - 1$ chains) then the

number of fuzzy subgroups of the maximal chain (i) is equal to $\frac{2^{n+1}}{2^2}$.

Inductively , if there is no distinguishing pair of subgroups but there is a distinguishing triple of subgroups in (i) , then the number of fuzzy subgroups

contributed by the maximal chain (i) is equal to $\frac{2^{n+1}}{2^3}$. Thus this argument continues inductively.

Example: 5.2.6.1

The group $G = \mathbf{Z}_{p^3} \times \mathbf{Z}_q$ has the following number of fuzzy subgroups

$2^5 - 1 + \frac{1}{2}[2^5] + \frac{1}{2}[2^5] + \frac{1}{2}[2^5] = 79$. These are computed using the above arguments as follows. Firstly we consider the four maximal chains of G :

$$(1) \mathbf{Z}_{p^3} + \mathbf{Z}_q \supset \mathbf{Z}_{p^2} + \mathbf{Z}_q^* \supset \mathbf{Z}_p + \mathbf{Z}_q^* \supset \mathbf{Z}_p + \{0\}^* \supset \{0\}$$

$$(2) \mathbf{Z}_{p^3} + \mathbf{Z}_q \supset \mathbf{Z}_{p^3} + \{0\}^* \supset \mathbf{Z}_{p^2} + \{0\} \supset \mathbf{Z}_p + \{0\} \supset \{0\}$$

$$(3) \mathbf{Z}_{p^3} + \mathbf{Z}_q \supset \mathbf{Z}_{p^2} + \mathbf{Z}_q \supset \mathbf{Z}_{p^2} + \{0\}^* \supset \mathbf{Z}_p + \{0\} \supset \{0\}$$

$$(4) \mathbf{Z}_{p^3} + \mathbf{Z}_q \supset \mathbf{Z}_{p^2} + \mathbf{Z}_q \supset \mathbf{Z}_p + \mathbf{Z}_q \supset \{0\} + \mathbf{Z}_q^* \supset \{0\}$$

Maximal chain (1) contributes $2^5 - 1$ fuzzy subgroups and all nontrivial subgroups are a distinguishing factor.

(2) contributes $\frac{2^5}{2}$ since the subgroup $\mathbf{Z}_{p^3} + \{0\}^*$ is a distinguishing factor (does not appear in (1))

(3) contributes $\frac{2^5}{2}$ since the subgroup $\mathbf{Z}_{p^2} + \{0\}^*$ is a distinguishing factor.

And finally maximal chain (4) contributes $\frac{2^5}{2}$ fuzzy subgroups because the subgroup $\{0\} + \mathbf{Z}_q$ distinguishes it from the other three maximal chains.

In examples 5.2.6.1 and 5.2.6.2 we use asterik to indicate the distinguishing factors in each chain.

Example: 5.2.6.2

Let $G = \mathbf{Z}_{72}$. G has the following maximal chains

- (1) $O \subset \mathbf{Z}_2^* \subset \mathbf{Z}_4^* \subset \mathbf{Z}_8^* \subset \mathbf{Z}_{24}^* \subset \mathbf{Z}_{72}$
- (2) $O \subset \mathbf{Z}_2 \subset \mathbf{Z}_4 \subset \mathbf{Z}_{12}^* \subset \mathbf{Z}_{24} \subset \mathbf{Z}_{72}$
- (3) $O \subset \mathbf{Z}_3^* \subset \mathbf{Z}_6 \subset \mathbf{Z}_{12} \subset \mathbf{Z}_{24} \subset \mathbf{Z}_{72}$
- (4) $O \subset \mathbf{Z}_2 \subset \mathbf{Z}_6^* \subset \mathbf{Z}_{12} \subset \mathbf{Z}_{24} \subset \mathbf{Z}_{72}$
- (5) $O \subset \mathbf{Z}_2 \subset \mathbf{Z}_4 \subset \mathbf{Z}_{12} \subset \mathbf{Z}_{36}^* \subset \mathbf{Z}_{72}$
- (6) $O \subset \mathbf{Z}_2^* \subset \mathbf{Z}_6^* \subset \mathbf{Z}_{12} \subset \mathbf{Z}_{36} \subset \mathbf{Z}_{72}$
- (7) $O \subset \mathbf{Z}_2 \subset \mathbf{Z}_6 \subset \mathbf{Z}_{18}^* \subset \mathbf{Z}_{36} \subset \mathbf{Z}_{72}$
- (8) $O \subset \mathbf{Z}_3^* \subset \mathbf{Z}_6^* \subset \mathbf{Z}_{12} \subset \mathbf{Z}_{36} \subset \mathbf{Z}_{72}$
- (9) $O \subset \mathbf{Z}_3 \subset \mathbf{Z}_6 \subset \mathbf{Z}_{18}^* \subset \mathbf{Z}_{36}^* \subset \mathbf{Z}_{72}$
- (10) $O \subset \mathbf{Z}_3 \subset \mathbf{Z}_9^* \subset \mathbf{Z}_{18} \subset \mathbf{Z}_{36} \subset \mathbf{Z}_{72}$

We have used stars to denote distinguishing factors. In the maximal chain (6) there is no single distinguishing factor, but there is a distinguishing pair \mathbf{Z}_2 and \mathbf{Z}_6 , implying

that (6) yields $\frac{2^6}{2^2} = 16$ fuzzy subgroups

Now using the propositions 5.2.4, 5.2.5, 5.2.6 and the arguments raised before, we have the fuzzy subgroups contributed by each maximal chain as follows

Maximal Chain	Number of Fuzzy subgroups
(1)	$2^6 - 1$
(2), (3), (4); (5), (7) and (10)	Each yields $\frac{2^6}{2} = 2^5$
(6), (8) and (9)	Each yields $\frac{2^6}{2^2} = 2^4$

Thus the total number of fuzzy subgroups of \mathbf{Z}_{72} is $2^6 - 1 + 6 \times 2^5 + 3 \times 2^4 = 303$.

Further justification of the process of counting fuzzy subgroups of $G = \mathbf{Z}_{p_1^{k_1}} \times \mathbf{Z}_{p_2^{k_2}}$:

Let (1) $O \subset G_1 \subset G_2 \subset G_3 = G$ and

(2) $O \subset H_1 \subset H_2 \subset H_3 = G$ with $H_1 \neq G_1$ and $H_2 \neq G_2$ be maximal chains.

Clearly there is another maximal chain besides (2) having H_1 or H_2 as a subgroup.

For instance if $G_2 \cap H_2 = 0$, then the chain $0 \subseteq H_1 \subseteq H_1 \oplus \langle g_1 \rangle \subseteq G$ is maximal and not equal to (1) or (2) where $g_1 \in G_1 \setminus H_1$.

Suppose $G_2 \cap H_2 \neq 0$, then $G_2 \cap H_2 = G_1$ or H_1 gives either $0 \subseteq H_1 \subseteq G_2 \subseteq G_3$ or $0 \subseteq G_1 \subseteq H_2 \subseteq H_3$ as a new maximal chain containing H_1 or H_2 . If $G_2 \cap H_2 \neq G_1$

and $G_2 \cap H_2 \neq H_1$, then $0 \subseteq G_2 \cap H_2 \subseteq H_2 \subseteq H_3$ is a new maximal chain containing H_2 .

Thus limiting a chain $(i), i \geq 2$, to one distinguishing subgroup or one distinguishing pair or triple etc, is justifiable and sensible for the ease of counting, since other subgroups not used in one chain will be used in other chains. So all fuzzy subgroups will be counted. Obviously the above justification extends to any chains of length $n+1, n \geq 3$.

Thus the result of this section holds even when $G = \mathbb{Z}_{p_1^{k_1}} + \mathbb{Z}_{p_2^{k_2}} + \mathbb{Z}_{p_3^{k_3}}$ where p_1, p_2 and p_3 are distinct primes.

5.3 Classification of fuzzy subgroups of $G = \mathbb{Z}_{p^n} + \mathbb{Z}_{q^m}$

Authors of [25] and [30] studied the classification of fuzzy subgroups of the

$G = \mathbb{Z}_{p^n} + \mathbb{Z}_{q^m}$. We list this preliminary work in the form of lemmas, for proofs refer to references

Lemma: 5.3.1

$G = \mathbb{Z}_{p^n} + \mathbb{Z}_q$ has $2^{n+1}(n+2) - 1$ fuzzy subgroups.

Proof [25]

Lemma: 5.3.2

$G = \mathbb{Z}_{p^n} + \mathbb{Z}_{q^2}$ has $2^{n+2+1} \sum_{r=0}^2 2^{-r} \binom{n}{n-r} \binom{2}{r} - 1$ distinct fuzzy subgroups for all $n \geq 2$

Lemma: 5.3.3

$G = \mathbb{Z}_{p^n} + \mathbb{Z}_{q^3}$ has $2^{n+3+1} \sum_{r=0}^3 2^{-r} \binom{n}{n-r} \binom{3}{r} - 1$ distinct fuzzy subgroups for all $n \geq 2$.

The above discussion motivates proposition 5.3.5 which was given in [30]. Our next aim is to provide a proof for Proposition 5.3.5 but before we embark on that we define a few combinatoric statements that we are going to use in this proof. We again make use of a general lattice diagram of subgroups and carry out extensions from the resultant nodes.

Definition: 5.3.4

We define (a) $\binom{n}{r} = 0$ for $r > n$

(b) $\binom{0}{0} = 1$. From the fact that $0! = 1$.

(c) $2^{k+1} \sum_{m=n-1}^{n-k} \sum_{r=0}^m 2^{-r} \binom{m}{r} \binom{n-k}{r} = 2^{k+1} \sum_{r=0}^m \sum_{m=n-1}^{n-k} \binom{m}{r} \binom{n-k}{r}$

(d) $\binom{n}{r} = \binom{n-1}{r} + \binom{n-1}{r-1}$ for $n \geq r$.

(e) $\binom{n}{r+1} = \binom{n-1}{r} + \binom{n-2}{r} + \dots + \binom{n-(2n-k)}{r} + \binom{k-n}{r+1}$ for $n \geq r+1$.

(f) $\binom{n}{r+1} = \binom{n-1}{r} + \binom{n-1}{r+1}$ from (d) above for $n-1 \geq r+1$

(g) $\binom{k-n+1}{r} = \binom{k-n}{r} + \binom{k-n}{r-1}$ from (d) above.

Proposition 5.3.5 below was given without proof by Ngcibi in [10], we provide a proof as a way of demonstrating how our counting technique works. As stated above we make use of the lattice diagram of subgroups and apply pin-extension to the given nodes.

Proposition: 5.3.5

$G = \mathbf{Z}_{p^n} + \mathbf{Z}_{q^m}$, $n \geq m$, has $2^{n+m+1} \sum_{r=0}^m 2^{-r} \binom{n}{n-r} \binom{m}{r} - 1$ fuzzy subgroups.

Proof

We induct on $m+n$. If we assume $n=1$ and $m=0$ then $G = \mathbf{Z}_p + \mathbf{Z}_{q^0} \cong \mathbf{Z}_p$, and this group from previous result has $2^{1+1} - 1 = 3$ distinct fuzzy subgroups. Using the formula with these values of $m=0$ and $n=1$ we have

$2^{1+0+1} \sum_{r=0}^0 2^{-r} \binom{1}{0} \binom{0}{0} - 1 = 2^2 \left(2^0 \binom{1}{0} \binom{0}{0} \right) - 1 = 4(1) - 1 = 3$ distinct fuzzy subgroups. It is

clear that if the roles of m and n are interchanged, the same will be true. Therefore the formula holds for $m + n = 1$.

Now we assume the formula is true for $m + n = k, (k > 1) \Rightarrow m = k - n$ that is

$$G = \mathbf{Z}_{p^n} + \mathbf{Z}_{q^{k-n}} \text{ has } 2^{n+k-n+1} \sum_{r=0}^{k-n} 2^{-r} \binom{n}{r} \binom{k-n}{r} - 1 \text{ fuzzy subgroups.}$$

We need to show that the formula is true for $m + n = k + 1$, that is $G = \mathbf{Z}_{p^n} + \mathbf{Z}_{q^{k+1-n}}$

has $2^{n+k+1-n+1} \sum_{r=0}^{k-n+1} 2^{-r} \binom{n}{r} \binom{k+1-n}{r} - 1 = 2^{k+2} \sum_{r=0}^{k-n+1} 2^{-r} \binom{n}{r} \binom{k-n+1}{r} - 1$ distinct fuzzy subgroups.

The lattice diagram of subgroups given below enables us to identify the subgroups from which to carry out the extensions. In this case we are going to extend from nodes $p^n q^{k-n}, p^{n-1} q^{k-n}, p^{n-2} q^{k-n}, \dots, p^{k-n-1} q^{k-n}, \dots, p^2 q^{k-n}, pq^{k-n}$ and q^{k-n} .

As before we denote a group $G = \mathbf{Z}_{p^{n-1}} + \mathbf{Z}_{q^{k+1-n}}$ by simply $p^{n-1} q^{k+1-n}$.

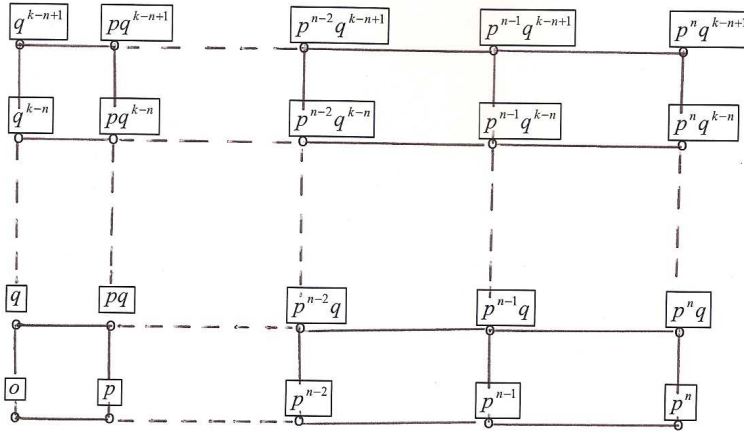

We know that the number of distinct keychains that end with a non-zero pin is one more than the number of those that end with zero pin. Thus the node $p^n q^{k-n}$ contributes

$$3 \times \frac{1}{2} \left[2^{n+k-n+1} \sum_{r=0}^{k-n} 2^{-r} \binom{n}{r} \binom{k-n}{r} - 1 + 1 \right] = \frac{3}{2} \left[2^{n+k-n+1} \sum_{r=0}^{k-n} 2^{-r} \binom{n}{r} \binom{n-k}{r} \right] \text{ non- equivalent}$$

fuzzy subgroups corresponding to keychains ending with a non-zero pin plus

$$\frac{1}{2} \left[2^{n+k-n+1} \sum_{r=0}^{k-n} 2^{-r} \binom{n}{r} \binom{n-k}{r} \right] - 1 \text{ fuzzy subgroups corresponding to keychains ending}$$

with a zero pin. This number equals

$$\frac{1}{2} \left[2^{n+k-n+1} \sum_{r=0}^{k-n} 2^{-r} \binom{n}{r} \binom{k-n}{r} \right] \times 4 - 1 = 2^{k+2} \sum_{r=0}^{k-n} 2^{-r} \binom{n}{r} \binom{k-n}{r} - 1 \text{ distinct fuzzy}$$

subgroups in the subgroup $p^n q^{k+1-n}$. (##)

Similarly the node $p^{n-1} q^{k-n}$ contributes

$$\frac{1}{2} \left[2^{n-1+k-n+1} \sum_{r=0}^{k-n} 2^{-r} \binom{n-1}{r} \binom{k-n}{r} \right] \times 4 = 2^{k+1} \sum_{r=0}^{k-n} 2^{-r} \binom{n-1}{r} \binom{k-n}{r} \text{ because when}$$

extending through $p^{n-1} q^{k-n}$ to $p^n q^{k-n+1}$ on the diagram given we observe that there are two routes that can be followed namely,

- (1) $p^{n-1} q^{k-n} \rightarrow p^n q^{k-n} \rightarrow p^n q^{k+1-n}$
- (2) $p^{n-1} q^{k-n} \rightarrow p^{n-1} q^{k+1-n} \rightarrow p^n q^{k+1-n}$.

We do not extend using route (1) because we have carried out extensions through node $p^{n-1} q^{k-n}$. Now keychains in the subgroup $p^{n-1} q^{k-n}$ are of the form $1\lambda_1 \dots \lambda_{k-1}$.

Now for $\lambda_{k-1} \neq 0$ we can only extend to $1\lambda_1 \lambda_2 \dots \lambda_{k-1} \lambda_{k-1} \lambda_{k-1}$, $1\lambda_1 \lambda_2 \dots \lambda_{k-1} \lambda_{k-1} \lambda_k$, $1\lambda_1 \lambda_2 \dots \lambda_{k-1} \lambda_k \lambda_k$, $1\lambda_1 \lambda_2 \dots \lambda_{k-1} \lambda_k \lambda_{k+1}$, $1\lambda_1 \lambda_2 \dots \lambda_{k-1} \lambda_{k-1} 0$, $1\lambda_1 \lambda_2 \dots \lambda_{k-1} \lambda_k 0$ and $1\lambda_1 \lambda_2 \dots \lambda_{k-1} 00$.

The three extensions given by the keychains $1\lambda_1 \lambda_2 \dots \lambda_{k-1} \lambda_{k-1} \lambda_{k-1}$, $1\lambda_1 \lambda_2 \dots \lambda_{k-1} \lambda_k \lambda_k$ and $1\lambda_1 \lambda_2 \dots \lambda_{k-1} 00$ have already been counted above when extending through $p^n q^{k-n}$.

We are left with the following keychains $1\lambda_1 \lambda_2 \dots \lambda_{k-1} \lambda_k \lambda_{k+1}$, $1\lambda_1 \lambda_2 \dots \lambda_{k-1} \lambda_{k-1} \lambda_k$, $1\lambda_1 \lambda_2 \dots \lambda_{k-1} \lambda_{k-1} 0$ and $1\lambda_1 \lambda_2 \dots \lambda_{k-1} \lambda_k 0$ in $p^n q^{k+1-n}$.

The first two will give rise to new fuzzy subgroups, while to the last one we can only attach a zero therefore do not result in any further new fuzzy subgroups in $p^n q^{k+1-n}$.

Therefore to calculate the contribution of node $p^{n-1} q^{k-n}$, we multiply by four, half the number of fuzzy subgroups of the group $G = \mathbf{Z}_{p^{n-1}} + \mathbf{Z}_{q^{k-n}}$ that end with nonzero pin.

Thus $p^{n-1} q^{k-n}$ yields

$$\frac{1}{2} \left[2^{n-1+k-n+1} \sum_{r=0}^{k-n} 2^{-r} \binom{n-1}{r} \binom{k-n}{r} - 1 + 1 \right] \times 4 = 2^{k+1} \sum_{r=0}^{k-n} 2^{-r} \binom{n-1}{r} \binom{k-n}{r} \text{ fuzzy}$$

subgroups in

$$p^n q^{k-n+1}.$$

Extending from the subgroup $p^{n-2}q^{k-n}$ we know that keychains on this node are of the form $1\lambda_1\lambda_2\dots\lambda_{k-2}$. Now for $\lambda_{k-2} \neq 0$ we can only extend to

$$\begin{aligned} &1\lambda_1\lambda_2\dots\lambda_{k-2}\lambda_{k-2}\lambda_{k-2}\lambda_{k-2}, 1\lambda_1\lambda_2\dots\lambda_{k-2}\lambda_{k-2}\lambda_{k-2}\lambda_{k-1}, 1\lambda_1\lambda_2\dots\lambda_{k-2}\lambda_{k-2}\lambda_{k-1}\lambda_{k-1}, \\ &1\lambda_1\lambda_2\dots\lambda_{k-2}\lambda_{k-1}\lambda_{k-1}\lambda_{k-1}, 1\lambda_1\lambda_2\dots\lambda_{k-2}\lambda_{k-1}\lambda_{k-1}\lambda_k, 1\lambda_1\lambda_2\dots\lambda_{k-2}\lambda_{k-2}\lambda_{k-1}\lambda_k, \\ &1\lambda_1\lambda_2\dots\lambda_{k-2}\lambda_{k-1}\lambda_{k-1}0, 1\lambda_1\lambda_2\dots\lambda_{k-2}\lambda_{k-2}\lambda_{k-2}0, 1\lambda_1\lambda_2\dots\lambda_{k-2}\lambda_{k-1}\lambda_k\lambda_k, 1\lambda_1\lambda_2\dots\lambda_{k-2}\lambda_{k-1}\lambda_k\lambda_{k+1} \\ &1\lambda_1\lambda_2\dots\lambda_{k-2}000, 1\lambda_1\lambda_2\dots\lambda_{k-2}\lambda_{k-2}\lambda_{k-1}0, 1\lambda_1\lambda_2\dots\lambda_{k-2}\lambda_{k-2}00, 1\lambda_1\lambda_2\dots\lambda_{k-2}\lambda_{k-1}\lambda_k0, \\ &1\lambda_1\lambda_2\dots\lambda_{k-2}\lambda_{k-1}00 \end{aligned}$$

We observe that this can be carried out through the three routes,

$$p^{n-2}q^{k-n} \rightarrow p^{n-1}q^{k-n} \rightarrow p^{n-1}q^{k-n+1} \rightarrow p^nq^{k-n+1} \quad (1)$$

$$p^{n-2}q^{k-n} \rightarrow p^{n-1}q^{k-n} \rightarrow p^nq^{k-n} \rightarrow p^nq^{k-n+1} \quad (2)$$

$$p^{n-2}q^{k-n} \rightarrow p^{n-2}q^{k-n+1} \rightarrow p^{n-1}q^{k-n+1} \rightarrow p^nq^{k-n+1} \quad (3)$$

We observe that routes (1) and (2) cannot be used here as they have been used before when extending from $p^{n-1}q^{k-n}$ and p^nq^{k-n} respectively. We also note that each of the keychains $1\lambda_1\lambda_2\dots\lambda_{k-2}\lambda_{k-2}\lambda_{k-2}\lambda_{k-2}$, $1\lambda_1\lambda_2\dots\lambda_{k-2}000$, $1\lambda_1\lambda_2\dots\lambda_{k-2}\lambda_{k-1}\lambda_{k-1}\lambda_{k-1}$ represents the same fuzzy subgroup in all three maximal chains (1), (2) and (3) above.

Listing down all the keychains and comparing, we find that the following seven distinct equivalence classes of fuzzy subgroups viewed as keychains have been counted before when extending from p^nq^{k-n} and $p^{n-1}q^{k-n}$, viz

$$\begin{aligned} &1\lambda_1\lambda_2\dots\lambda_{k-2}\lambda_{k-2}\lambda_{k-2}\lambda_{k-1}, 1\lambda_1\lambda_2\dots\lambda_{k-2}\lambda_{k-1}\lambda_{k-1}\lambda_k, 1\lambda_1\lambda_2\dots\lambda_{k-2}\lambda_{k-1}\lambda_{k-1}0, \\ &1\lambda_1\lambda_2\dots\lambda_{k-2}\lambda_{k-2}\lambda_{k-2}\lambda_{k-2}, 1\lambda_1\lambda_2\dots\lambda_{k-2}\lambda_{k-1}\lambda_{k-1}\lambda_{k-1}, 1\lambda_1\lambda_2\dots\lambda_{k-2}\lambda_{k-2}\lambda_{k-2}0 \text{ and} \\ &1\lambda_1\lambda_2\dots\lambda_{k-2}000. \end{aligned}$$

Thus the node $p^{n-2}q^{k-n}$ contributes

$$\frac{1}{2} \left[2^{n-2+k-n+1} \sum_{r=0}^{k-n} 2^{-r} \binom{n-2}{r} \binom{k-n}{r} \right] \times 8 = 2^{k+1} \sum_{r=0}^{k-n} 2^{-r} \binom{n-2}{r} \binom{k-n}{r} \text{ distinct fuzzy}$$

subgroups.

Continuing with the process, we get the following number of distinct fuzzy subgroups for each node:

The node $p^{n-3}q^{k-n}$

$$\text{has } \frac{1}{2} \left[2^{n-3+k-n+1} \sum_{r=0}^{k-n} 2^{-r} \binom{n-3}{r} \binom{k-n}{r} \right] \times 16 = 2^{k+1} \sum_{r=0}^{k-n} 2^{-r} \binom{n-3}{r} \binom{k-n}{r} \text{ distinct fuzzy}$$

subgroups.

.

.

.

$$\begin{aligned} \text{The node } p^{k-n+1}q^{k-n} \text{ has } & \frac{1}{2} \left[2^{k-n+1+k-n+1} \sum_{r=0}^{k-n} 2^{-r} \binom{k-n+1}{r} \binom{k-n}{r} \right] \times 2^{2n-k} \\ & = 2^{k+1} \sum_{r=0}^{k-n} 2^{-r} \binom{k-n+1}{r} \binom{k-n}{r} \end{aligned}$$

$$\begin{aligned} \text{The node } p^{k-n}q^{k-n} \text{ has } & \frac{1}{2} \left[2^{k-n+k-n+1} \sum_{r=0}^{k-n} 2^{-r} \binom{k-n}{r} \binom{k-n}{r} \right] \times 2^{2n-k+1} \\ & = 2^{k+1} \sum_{r=0}^{k-n} 2^{-r} \binom{k-n}{r} \binom{k-n}{r} \end{aligned}$$

$$\begin{aligned} \text{The node } p^{k-n-1}q^{k-n} \text{ has } & \frac{1}{2} \left[2^{k-n-1+k-n+1} \sum_{r=0}^{k-n-1} 2^{-r} \binom{k-n-1}{r} \binom{k-n}{r} \right] \times 2^{2n-k+2} \\ & = 2^{k+1} \sum_{r=0}^{k-n-1} 2^{-r} \binom{k-n-1}{r} \binom{k-n}{r} \end{aligned}$$

.

.

.

$$\begin{aligned} \text{The node } p^3q^{k-n} \text{ has } & \frac{1}{2} \left[2^{3+k-n+1} \sum_{r=0}^3 2^{-r} \binom{3}{r} \binom{k-n}{r} \right] \times 2^{n-2} \\ & = 2^{k+1} \sum_{r=0}^3 2^{-r} \binom{3}{r} \binom{k-n}{r} \end{aligned}$$

$$\begin{aligned} \text{The node } p^2q^{k-n} \text{ has } & \frac{1}{2} \left[2^{-r} \sum_{r=0}^2 2^{-r} \binom{2}{r} \binom{k-n}{r} \right] \times 2^{n-1} \\ & = 2^{k+1} \sum_{r=0}^2 2^{-r} \binom{2}{r} \binom{k-n}{r} \end{aligned}$$

$$\text{The node } pq^{k-n} \text{ has } \frac{1}{2} \left[2^{1+k-n+1} \sum_{r=0}^1 2^{-r} \binom{1}{r} \binom{k-n}{r} \right] \times 2^n$$

$$= 2^{k+1} \sum_{r=0}^1 2^{-r} \binom{1}{r} \binom{k-n}{r}$$

The node q^{k-n} has $\frac{1}{2} \left[2^{o+k-n+1} \sum_{r=0}^0 2^{-r} \binom{0}{r} \binom{k-n}{r} \right] \times 2^{n+1}$

$$= 2^{k+1} \sum_{r=0}^0 2^{-r} \binom{0}{r} \binom{k-n}{r}$$

Now to sum up these we consider three classes of equivalent fuzzy subgroups precisely those that are obtained by making extensions from

(a) nodes $p^{n-1}q^{k-n}$ to $p^{k-n}q^{k-n}$

(b) nodes q^{k-n} to $p^{k-n-1}q^{k-n}$

(c) node p^nq^{k-n}

(a) yields $2^{k+1} \sum_{r=0}^{n-1} 2^{-r} \binom{n-1}{r} \binom{k-n}{r}$

$$+ 2^{k+1} \sum_{r=0}^{n-2} 2^{-r} \binom{n-2}{r} \binom{k-n}{r} + \dots + 2^{k+1} \sum_{r=0}^{k-n+1} 2^{-r} \binom{k-n+1}{r} \binom{k-n}{r} +$$

$$2^{k+1} \sum_{r=0}^{k-n} 2^{-r} \binom{k-n}{r} \binom{k-n}{r}$$

$$= 2^{k+1} \sum_{m=n-1}^{k-n} \sum_{r=0}^m 2^{-r} \binom{m}{r} \binom{k-n}{r}$$

$$= 2^{k+1} \sum_{r=0}^{k-n} \sum_{m=n-1}^{k-n} 2^{-r} \binom{m}{r} \binom{k-n}{r}$$

(b) yields $2^{k+1} \sum_{r=0}^{k-n-1} 2^{-r} \binom{k-n-1}{r} \binom{k-n}{r} +$

$$2^{k+1} \sum_{r=0}^{k-n-2} 2^{-r} \binom{k-n-2}{r} \binom{k-n}{r} + \dots + 2^{k+1} \sum_{r=0}^3 2^{-r} \binom{3}{r} \binom{k-n}{r}$$

$$+ 2^{k+1} \sum_{r=0}^2 2^{-r} \binom{2}{r} \binom{k-n}{r} + 2^{k+1} \sum_{r=0}^1 2^{-r} \binom{1}{r} \binom{k-n}{r} + 2^{k+1} \sum_{r=0}^0 2^{-r} \binom{0}{r} \binom{k-n}{r}$$

$$= 2^{k+1} \sum_{m=0}^{k-n-1} \sum_{r=0}^m 2^{-r} \binom{m}{r} \binom{k-n}{r}$$

$$= 2^{k+1} \sum_{r=0}^{k-n-1} \sum_{m=0}^{k-n-1} 2^{-r} \binom{m}{r} \binom{k-n}{r}$$

(c) yields $2^{k+1} \sum_{r=0}^{k-n} 2^{-r} \binom{n}{r} \binom{k-n}{r} - 1$ (from(##))

Now (a), (b) and (c) will give the following sum

$$\begin{aligned} & 2^{k+1} \sum_{r=0}^{k-n} \sum_{m=n-1}^{k-n} 2^{-r} \binom{m}{r} \binom{k-n}{r} + 2^{k+1} \sum_{r=0}^{k-n-1} \sum_{m=0}^{k-n-1} 2^{-r} \binom{m}{r} \binom{k-n}{r} + 2^{k+1} \sum_{r=0}^{k-n} 2^{-r} \binom{n}{r} \binom{k-n}{r} - 1 \\ &= 2^{k+1} \sum_{r=0}^{k-n} 2^{-r} \left[\binom{n-1}{r} + \binom{n-2}{r} + \dots + \binom{k-n}{r} \right] \binom{k-n}{r} \\ &+ 2^{k+1} \sum_{r=0}^{k-n-1} 2^{-r} \left[\binom{0}{r} + \binom{1}{r} + \dots + \binom{k-n-1}{r} \right] \binom{k-n}{r} + 2^{k+1} \sum_{r=0}^{k-n} 2^{-r} (2) \binom{n}{r} \binom{k-n}{r} - 1 \\ &= 2^{k+1} \sum_{r=0}^{k-n} 2^{-r} \binom{k-n}{r} \left[\binom{0}{r} + \binom{1}{r} + \dots + \binom{k-n-1}{r} + \binom{k-n}{r} + \dots + \binom{n-1}{r} \right] \\ &+ 2^{k+1} \sum_{r=0}^{k-n} 2^{-r} (2) \binom{n}{r} \binom{k-n}{r} - 1 \\ &= 2^{k+1} \sum_{r=0}^{k-n} 2^{-r} \binom{k-n}{r} \left[\binom{0}{r} + \binom{1}{r} + \dots + \binom{k-n}{r} + \dots + \binom{n-1}{r} + \binom{n}{r} + \binom{n}{r} \right] - 1 \end{aligned}$$

But $\binom{n+1}{r+1} = \binom{n}{r} + \binom{n-1}{r} + \binom{n-2}{r} + \dots + \binom{k-n}{r} + \dots + 1$, therefore the sum becomes

$$2^{k+1} \sum_{r=0}^{k-n} 2^{-r} \binom{k-n}{r} \left[\binom{n+1}{r+1} + \binom{n}{r} \right] - 1.$$

Now since $\binom{n+1}{r+1} = \binom{n}{r} + \binom{n}{r+1}$, by Definition (f), we then have

$$\begin{aligned} & 2^{k+1} \sum_{r=0}^{k-n} 2^{-r} \binom{k-n}{r} \left[2 \binom{n}{r} + \binom{n}{r+1} \right] - 1 \\ &= 2^{k+2} \sum_{r=0}^{k-n} 2^{-r} \binom{k-n}{r} \binom{n}{r} + 2^{k+1} \sum_{r=0}^{k-n} 2^{-r} \binom{k-n}{r} \binom{n}{r+1} - 1 \\ &= 2^{k+2} \sum_{r=0}^{k-n} 2^{-r} \binom{k-n}{r} \binom{n}{r} + \frac{2^{k+1}}{2} \sum_{r=1}^{k-n+1} 2^{-(r-1)} \binom{k-n}{r-1} \binom{n}{r} - 1 \\ &= 2^{k+2} \sum_{r=0}^{k-n} 2^{-r} \binom{k-n}{r} \binom{n}{r} + 2^{k+2} \sum_{r=1}^{k-n+1} 2^{-r} \binom{k-n}{r-1} \binom{n}{r} - 1 \end{aligned}$$

$$= 2^{k+2} + 2^{k+2} \sum_{r=1}^{k-n+1} 2^{-r} \binom{k-n}{r} \binom{n}{r} - \left[2^{k+2} (2^{-(k-n+1)}) \binom{k-n}{k-n+1} \binom{n}{k-n+1} \right]$$

$$+ 2^{k+2} \sum_{r=1}^{k-n+1} 2^{-r} \binom{k-n}{r-1} \binom{n}{r} - 1$$

But $\left[2^{k+2} (2^{-(k-n+1)}) \binom{k-n}{k-n+1} \binom{n}{k-n+1} \right] = 0$ since $\binom{m}{r} = 0$ for $m < r$, thus we have

the sum

$$2^{k+2} + 2^{k+2} \sum_{r=1}^{k-n+1} 2^{-r} \binom{k-n}{r} \binom{n}{r} + 0 + 2^{k+2} \sum_{r=1}^{k-n+1} 2^{-r} \binom{k-n}{r-1} \binom{n}{r} - 1$$

$$= 2^{k+2} + 2^{k+2} \sum_{r=1}^{k-n+1} 2^{-r} \left[\binom{k-n}{r} + \binom{k-n}{r-1} \right] \binom{n}{r} - 1 \text{ (Since } \binom{k-n+1}{r} = \binom{k-n}{r} + \binom{k-n}{r-1} \text{)}$$

$$= 2^{k+2} \sum_{r=0}^{k-n+1} 2^{-r} \binom{k-n+1}{r} \binom{n}{r} - 1.$$

Therefore the Proposition is true for $n + m = k + 1$ which establishes the result.

Thus $G = Z_{p^n} + Z_{q^m}$, $n \geq m$, has $2^{n+m+1} \sum_{r=0}^m 2^{-r} \binom{n}{n-r} \binom{m}{r} - 1$ fuzzy subgroups. \square

5.4 Classification of fuzzy subgroups of $G = Z_{p^n} + Z_q + Z_{r^k}$ for $k = 1, 2, 3, 4$

5.4.1 On fuzzy subgroups of $G = Z_{p^n} + Z_q + Z_r$

For the case $n = 1$ we have the following maximal chains:

$$Z_p + Z_q + Z_r \supset Z_p + Z_q + \{0\} \supset Z_p + \{0\} + \{0\} \supset \{0\}$$

$$Z_p + Z_q + Z_r \supset Z_p + Z_q + \{0\} \supset \{0\} + Z_q + \{0\} \supset \{0\}$$

$$Z_p + Z_q + Z_r \supset Z_p + \{0\} + Z_r \supset Z_p + \{0\} + \{0\} \supset \{0\}$$

$$Z_p + Z_q + Z_r \supset Z_p + \{0\} + Z_r \supset \{0\} + \{0\} + Z_r \supset \{0\}$$

$$Z_p + Z_q + Z_r \supset \{0\} + Z_q + Z_r \supset \{0\} + \{0\} + Z_r \supset \{0\}$$

$$Z_p + Z_q + Z_r \supset \{0\} + Z_q + Z_r \supset \{0\} + Z_q + \{0\} \supset \{0\}$$

Calculating the number of equivalence classes of fuzzy subgroups, we use the

previous technique and obtain $2^4 - 1 + 2^3 + 2^3 + 2^3 + 2^3 + 2^2 = 6 \times 2^3 + 2^2 - 1$

$= 2^{1+1} [1^2 + 6(1) + 6] - 1$ distinct fuzzy subgroups.

Using the same technique for higher values of n we obtain the following number for each group in the form of a table.

n	Group	Number of Maximal Chains	Number of fuzzy subgroups
2	$\mathbf{Z}_{p^2} + \mathbf{Z}_q + \mathbf{Z}_r$	12	$2^5 - 1 + 7 \times 2^4 + 4 \times 2^3 = 9 \times 2^4 + 4 \times 2^3 - 1$ $= 2^{2+1} [2^2 + 6(2) + 6] - 1$
3	$\mathbf{Z}_{p^3} + \mathbf{Z}_q + \mathbf{Z}_r$	20	$2^6 - 1 + 10 \times 2^5 + 9 \times 2^4 = 12 \times 2^5 + 9 \times 2^4 - 1$ $= 2^{3+1} [3^2 + 6(3) + 6] - 1$
4	$\mathbf{Z}_{p^4} + \mathbf{Z}_q + \mathbf{Z}_r$	30	$2^7 - 1 + 13 \times 2^6 + 16 \times 2^5 - 1 = 15 \times 2^6 + 16 \times 2^5 - 1$ $= 2^{4+1} [4^2 + 6(4) + 6] - 1$
.	.	.	.
.	.	.	.
.	.	.	.
k	$\mathbf{Z}_{p^k} + \mathbf{Z}_q + \mathbf{Z}_r$	$(k+1)(k+2)$ Lemma 4.1.7	$2^{k+1} [k^2 + 6(k) + 6] - 1$

This table motivates proposition 5.4.2

Proposition: 5.4.2

The number $P(n)$ of equivalence classes of fuzzy subgroups for the group $G = \mathbf{Z}_{p^n} + \mathbf{Z}_q + \mathbf{Z}_r$ is $2^{n+1} [n^2 + 6n + 6] - 1$ for $n \geq 1$

Proof

We are going to make use of the lattice diagram of subgroups and induct on n

We denote by $p^k qr$ the group $G = \mathbf{Z}_{p^k} + \mathbf{Z}_q + \mathbf{Z}_r$.

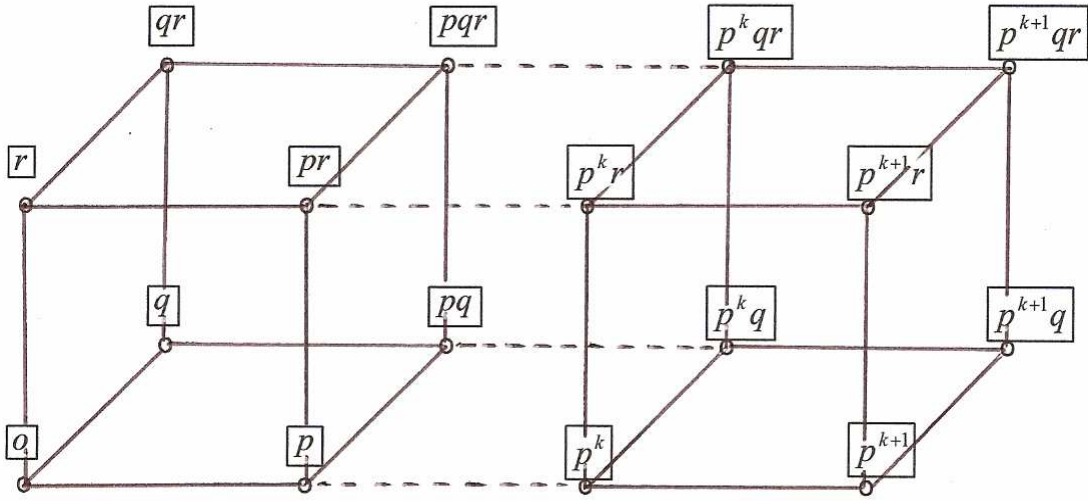

Lattice Diagram of $p^k qr$ and $p^{k+1} qr$

The cases $n = 1, 2, 3, 4$ have been shown to hold in the above preliminary work. Now assume that $P(k)$ is true, that is $G = Z_{p^k} + Z_q + Z_r$ has $2^{k+1}[k^2 + 6k + 6] - 1$

equivalence classes of fuzzy subgroups. There are $\frac{1}{2}[2^{k+1}(k^2 + 6k + 6) - 1 + 1]$ fuzzy subgroups (viewed as keychains) ending with a nonzero pin and

$\frac{1}{2}[2^{k+1}(k^2 + 6k + 6)] - 1$ ending with a zero pin. The former each yields three further

fuzzy subgroups in the subgroup $p^{k+1} qr$ while the latter remains the same as we can only attach a zero to a zero pin. This is so because a keychain in $p^k qr$ is of the

form $1\lambda_1\lambda_2\dots\lambda_{k+2}$. Now with $\lambda_{k+2} \neq 0$ we can only extend to $1\lambda_1\lambda_2\dots\lambda_{k+2}\lambda_{k+2}$,

$1\lambda_1\lambda_2\dots\lambda_{k+2}\lambda_{k+3}$ and $1\lambda_1\lambda_2\dots\lambda_{k+2}0$ subgroups in $p^{k+1} qr$. Thus we have

$$\frac{1}{2}[2^{k+1}(k^2 + 6k + 6) - 1 + 1] \times 3 + \frac{1}{2}[2^{k+1}(k^2 + 6k + 6)] - 1 =$$

$$\frac{1}{2}[2^{k+1}(k^2 + 6k + 6)] \times 4 - 1 \text{ distinct fuzzy subgroups.}$$

Next we have the node $p^k r$: from theorem 3.2.18 $p^k r$ has $2^{k+1}(k+2)-1$ fuzzy subgroups. We have established that if these subgroups are considered as keychains, the number of those with non-zero pin-ends is one more than the number of those with zero pin-ends. So we have $\frac{1}{2}[2^{k+1}(k+2)-1+1]$ fuzzy subgroups ending with non-zero pins. We discard those ending with zero pins as they do not give any new fuzzy subgroups because we can attach only a zero to a zero pin. Keychains in $p^k r$ are of the form $1\lambda_1\lambda_2\dots\lambda_{k+1}$. Now with $\lambda_{k+1} \neq 0$, we can only extend to $1\lambda_1\lambda_2\dots\lambda_{k+1}\lambda_{k+1}\lambda_{k+1}$, $1\lambda_1\lambda_2\dots\lambda_{k+1}\lambda_{k+1}\lambda_{k+2}$, $1\lambda_1\lambda_2\dots\lambda_{k+1}\lambda_{k+2}\lambda_{k+2}$, $1\lambda_1\lambda_2\dots\lambda_{k+1}\lambda_{k+2}\lambda_{k+3}$, $1\lambda_1\lambda_2\dots\lambda_{k+1}\lambda_{k+1}0$, $1\lambda_1\lambda_2\dots\lambda_{k+1}\lambda_{k+2}0$, $1\lambda_1\lambda_2\dots\lambda_{k+1}00$. The following four keychains, $1\lambda_1\lambda_2\dots\lambda_{k+1}\lambda_{k+1}\lambda_{k+2}$, $1\lambda_1\lambda_2\dots\lambda_{k+1}\lambda_{k+2}\lambda_{k+3}$, $1\lambda_1\lambda_2\dots\lambda_{k+1}\lambda_{k+2}0$ and $1\lambda_1\lambda_2\dots\lambda_{k+1}\lambda_{k+1}0$ have not been counted before, so they will effectively give rise to further fuzzy subgroups in $p^{k+1}qr$, hence we multiply the number of distinct fuzzy subgroups of $p^k r$ by four. Thus $\frac{1}{2}[2^{k+1}(k+2)-1+1]$ becomes

$\frac{1}{2}[2^{k+1}(k+2)-1+1] \times 4 = \frac{1}{2}[2^{k+1}(k+2)] \times 4 = 2^{k+2}(k+2)$ in $p^{k+1}qr$. Therefore the subgroup $p^k r$ yields $2^{k+2}(k+2)$ fuzzy subgroups in the subgroup $p^{k+1}qr$.

Similarly the node $p^k q$ yields $2^{k+2}(k+2)$ distinct fuzzy subgroups.

There are two routes when extending from the node p^k namely

$$p^k \rightarrow p^{k+1} \rightarrow p^{k+1}q \rightarrow p^{k+1}qr$$

$$p^k \rightarrow p^{k+1} \rightarrow p^{k+1}r \rightarrow p^{k+1}qr$$

From theorem 3.2.11, p^k has $2^{k+1}-1$ non-equivalent fuzzy subgroups. Keychains in this node are of the form $1\lambda_1\dots\lambda_k$. Now with $\lambda_k \neq 0$ we can only extend to fifteen fuzzy subgroups in $p^{k+1}qr$; these are:

$$\begin{aligned} &1\lambda_1\dots\lambda_k\lambda_k\lambda_k\lambda_k, 1\lambda_1\dots\lambda_k\lambda_k\lambda_k\lambda_{k+1}, 1\lambda_1\dots\lambda_k\lambda_k\lambda_k0, 1\lambda_1\dots\lambda_k\lambda_k\lambda_{k+1}\lambda_{k+1}, \\ &, 1\lambda_1\dots\lambda_k\lambda_{k+1}\lambda_{k+1}\lambda_{k+1}, 1\lambda_1\dots\lambda_k\lambda_{k+1}\lambda_{k+1}\lambda_{k+2}, 1\lambda_1\dots\lambda_k\lambda_{k+1}\lambda_{k+1}0, 1\lambda_1\dots\lambda_k000, \\ &1\lambda_1\dots\lambda_k\lambda_k\lambda_{k+1}\lambda_{k+2}, 1\lambda_1\dots\lambda_k\lambda_k\lambda_{k+1}0, 1\lambda_1\dots\lambda_k\lambda_k00, 1\lambda_1\dots\lambda_k\lambda_{k+1}\lambda_{k+2}\lambda_{k+2}, \\ &1\lambda_1\dots\lambda_k\lambda_{k+1}\lambda_{k+2}\lambda_{k+3}, 1\lambda_1\dots\lambda_k\lambda_{k+1}\lambda_{k+2}0, 1\lambda_1\dots\lambda_k\lambda_{k+1}00. \end{aligned}$$

The following seven fuzzy subgroups viewed as keychains,

$$\begin{aligned} &1\lambda_1\dots\lambda_k\lambda_k\lambda_k\lambda_k, 1\lambda_1\dots\lambda_k\lambda_{k+1}\lambda_{k+1}\lambda_{k+1}, 1\lambda_1\dots\lambda_k\lambda_{k+1}\lambda_{k+1}\lambda_{k+2}, 1\lambda_1\dots\lambda_k\lambda_{k+1}\lambda_{k+1}0, \\ &1\lambda_1\dots\lambda_k000, 1\lambda_1\dots\lambda_k\lambda_k\lambda_k0 \text{ and } 1\lambda_1\dots\lambda_k\lambda_k\lambda_k\lambda_{k+1} \end{aligned}$$

have been counted before. Thus only eight of the subgroups of p^k will give rise to new fuzzy subgroups. Hence $\frac{1}{2}[2^{k+1}]$ in

p^k becomes $\frac{1}{2}[2^{k+1}] \times 8 = (2^{k+1}) \times 4$ in $p^{k+1}qr$. The second route has been used once

before, thus we take half of $(2^{k+1}) \times 4$, as some would have been counted already,

yielding $\frac{1}{2}\left[\frac{1}{2}(2^{k+1}) \times 8\right] = 4(2^k)$ distinct fuzzy subgroups.

The total from all these nodes give us this sum

$$\frac{1}{2}[2^{k+1}(k^2 + 6k + 6)] \times 4 - 1 + 2^{k+2}(k+2) + (k+2)2^{k+2} + 4 \times (2^{k+1}) + 4 \times (2^k)$$

$$= 2^{k+2}[k^2 + 6k + 6 + 2k + 4 + 2 + 1] - 1$$

$$= 2^{k+2}[k^2 + 8k + 13] - 1$$

$$= 2^{(k+1)+1}[(k+1)^2 + 6(k+1) + 6] - 1 \text{ which shows that } P(k+1) \text{ is true.} \quad \square$$

5.4.3 The group $G = Z_{p^n} + Z_q + Z_{r^2}$

We aim to establish a formula for the number of distinct fuzzy subgroups of the group $G = Z_{p^n} + Z_q + Z_{r^2}$ for all $n \geq 1$.

Illustration One: The group $G = Z_{p^2} + Z_q + Z_{r^2}$

We note that for the case $n = 1$ we have the group $G = Z_p + Z_q + Z_{r^2}$ which by Proposition 5.4.2 and symmetry has $2^{2+1}[2^2 + 6(2) + 6] - 1 = 175$ non-equivalent fuzzy subgroups.

For $n = 2$ we have the group $G = Z_{p^2} + Z_q + Z_{r^2}$. We execute the lattice diagram of subgroups below and extend from the following base nodes, p^2qr , pqr , p^2r , pr , qr and r .

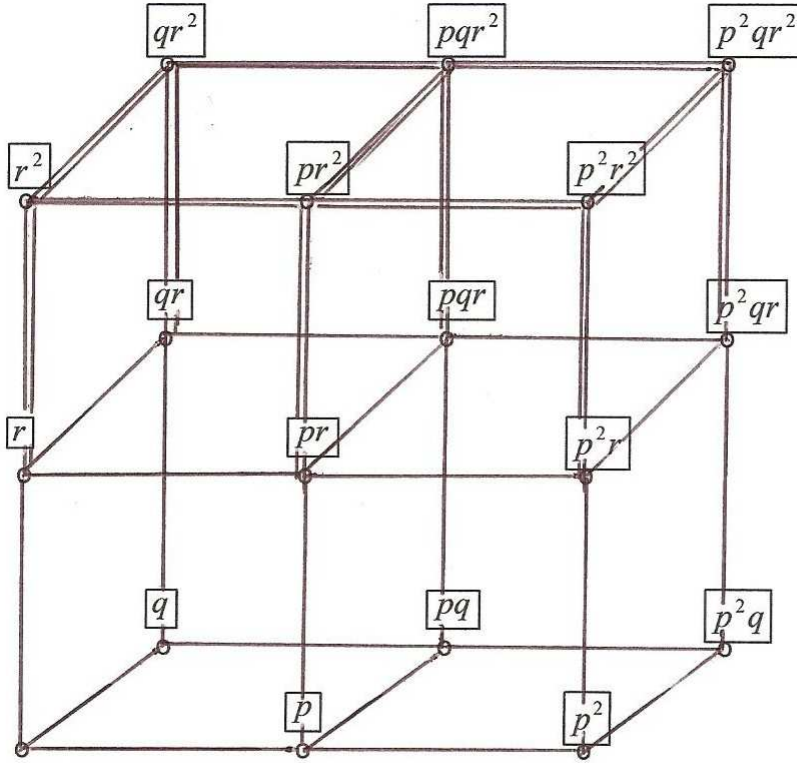

The node p^2qr has $2^{2+1}[2^2 + 6(2) + 6] - 1 = 175$ fuzzy subgroups by Proposition 5.4.2. We know that the number of fuzzy subgroups ending with a zero pin, viewed as keychains is one more than the number of fuzzy subgroups ending with a zero pin.

Keychains in p^2qr are of the form $1\lambda_1\lambda_2\lambda_3\lambda_4$ for $1 \geq \lambda_1 \geq \lambda_2 \geq \lambda_3 \geq \lambda_4 \geq 0$. Now for $\lambda_4 \neq 0$ we can only extend to $1\lambda_1\lambda_2\lambda_3\lambda_4\lambda_4$, $1\lambda_1\lambda_2\lambda_3\lambda_4\lambda_5$ or $1\lambda_1\lambda_2\lambda_3\lambda_40$

therefore $\frac{1}{2}[2^{2+1}(2^2 + 6(2) + 6) - 1 + 1]$ in p^2qr becomes $\frac{1}{2}[2^{2+1}(2^2 + 6(2) + 6)] \times 3$ in

p^2qr^2 and $\frac{1}{2}[2^{2+1}(2^2 + 6(2) + 6)] - 1$ remains the same because on zero we can only

attach a zero. Thus we have a total of

$$\frac{1}{2}[2^{2+1}(2^2 + 6(2) + 6) - 1 + 1] \times 3 + \frac{1}{2}[2^{2+1}(2^2 + 6(2) + 6)] - 1 = 351 \text{ distinct fuzzy}$$

subgroups for this node.

Node p^2r from theorem 3.2.18 has $2^{2+1}(2 + 2) - 1$ fuzzy subgroups. Fuzzy subgroups that have zero pin-ends will not give rise to any new fuzzy subgroups in

and are one less than those with zero pin-ends. This extension is carried out through the following route $p^2r \rightarrow p^2r^2 \rightarrow p^2qr^2$.

Keychains in p^2r are of the form $1\lambda_1\lambda_2\lambda_3$. Now for $\lambda_3 \neq 0$ we can only extend to $1\lambda_1\lambda_2\lambda_3\lambda_3\lambda_3$, $1\lambda_1\lambda_2\lambda_3\lambda_3\lambda_4$, $1\lambda_1\lambda_2\lambda_3\lambda_4\lambda_4$, $1\lambda_1\lambda_2\lambda_3\lambda_4\lambda_5$, $1\lambda_1\lambda_2\lambda_3\lambda_30$, $1\lambda_1\lambda_2\lambda_3\lambda_40$ and $1\lambda_1\lambda_2\lambda_300$ for $0 \leq \lambda_5 \leq \lambda_4 \leq \lambda_3 \leq \lambda_2 \leq \lambda_1 \leq 1$ in p^2qr^2 . Of these, three end with zero pins, thus we can only attach a zero and therefore do not result in new fuzzy subgroups in p^2qr^2 . The other four result in new fuzzy subgroups, thus

$$\frac{1}{2}[2^{2+1}(2+2)-1+1]=16 \text{ becomes } 16 \times 4 = 64 \text{ in } p^2qr^2.$$

Node pqr , from Proposition 5.4.2, has $2^{1+1}[1+6+6]-1 = 51$ fuzzy subgroups. Using a similar argument as above, $\frac{1}{2}[2^{1+1}(1^2+6(1)+6)-1+1]=26$ becomes $26 \times 4 = 104$.

Node pr , from theorem 3.2.18, has $2^{1+1}[1+2]-1 = 11$ distinct fuzzy subgroups. Six have non-zero pin-ends. We extend through the following routes:

$pr \rightarrow pr^2 \rightarrow p^2r^2 \rightarrow p^2qr^2$ and $pr \rightarrow pr^2 \rightarrow pqr^2 \rightarrow p^2qr^2$. Now a keychain in pr is of the form $1\lambda_1\lambda_2$ for $1 \geq \lambda_1 \geq \lambda_2 \geq 0$, so we can only extend to

$1\lambda_1\lambda_2\lambda_2\lambda_2\lambda_2$, $1\lambda_1\lambda_2\lambda_2\lambda_2\lambda_3$, $1\lambda_1\lambda_2\lambda_2\lambda_20$, $1\lambda_1\lambda_2\lambda_2\lambda_3\lambda_3$, $1\lambda_1\lambda_2\lambda_2\lambda_3\lambda_4$, $1\lambda_1\lambda_2\lambda_2\lambda_30$,

$1\lambda_1\lambda_2\lambda_200$, $1\lambda_1\lambda_2\lambda_3\lambda_3\lambda_3$, $1\lambda_1\lambda_2\lambda_3\lambda_3\lambda_4$, $1\lambda_1\lambda_2\lambda_3\lambda_30$, $1\lambda_1\lambda_2\lambda_3\lambda_4\lambda_4$, $1\lambda_1\lambda_2\lambda_3\lambda_4\lambda_5$,

$1\lambda_1\lambda_2\lambda_3\lambda_40$, $1\lambda_1\lambda_2\lambda_300$, $1\lambda_1\lambda_2000$. Eight have non-zero pin-ends which means that

this node will have $6 \times 8 = 48$ distinct fuzzy subgroups. There are two routes to

extend through, namely $pr \rightarrow pr^2 \rightarrow p^2r^2 \rightarrow p^2qr^2$ and

$pr \rightarrow pr^2 \rightarrow pqr^2 \rightarrow p^2qr^2$. The above count is for the former while the latter

yields $\frac{1}{2}[2^{1+1}(1+2)] \times 8 = 24$ fuzzy subgroups as the other half would have been

counted in the former.

From the node qr we extend through this route $qr \rightarrow qr^2pqr^2 \rightarrow p^2qr^2$. Using a similar argument as above, we obtain

$$6 \times 8 = 48 \text{ distinct fuzzy subgroups for this node.}$$

From the node r we may extend using the following three routes:

$$r \rightarrow r^2 \rightarrow qr^2 \rightarrow pqr^2 \rightarrow p^2qr^2 \text{ (1)}$$

$$r \rightarrow r^2 \rightarrow pr^2 \rightarrow pqr^2 \rightarrow p^2qr^2 \text{ (2)}$$

$$r \rightarrow r^2 \rightarrow pr^2 \rightarrow p^2r^2 \rightarrow p^2qr^2 (3)$$

Now the subgroup r has, from theorem 3.2.11, three fuzzy subgroups of which two end with a nonzero pin. Keychains in r when extending to p^2qr^2 result in 32

extensions. So the route (1) will yield $\frac{1}{2}[2] \times 32 = 2 \times 16 = 32$ fuzzy subgroups.

The other two routes each yields $2 \times 8 = 16$, this is so because we observe that if we list all the 32 extensions, some are distinct in all three chains while some will represent identical fuzzy subgroups in either (1) and (2) or (2) and (3). For example the fuzzy subgroups $1\lambda_1\lambda_1\lambda_2\lambda_3\lambda_4, 1\lambda_1\lambda_1\lambda_2\lambda_30$ and $1\lambda_1\lambda_1\lambda_3\lambda_4\lambda_5$ viewed as keychains have not been counted before, while $1\lambda_1\lambda_1\lambda_1\lambda_1\lambda_1, 1\lambda_1\lambda_1000$ and $1\lambda_1\lambda_1\lambda_2\lambda_2\lambda_2$ have been counted previously. On the other hand extensions like $1\lambda_1\lambda_1\lambda_2\lambda_2\lambda_3$ and $1\lambda_1\lambda_1\lambda_1\lambda_10$ represent the same fuzzy subgroups in routes (1) and (2) while $1\lambda_1\lambda_1\lambda_200, 1\lambda_1\lambda_1\lambda_2\lambda_3\lambda_3$ and $1\lambda_1\lambda_1\lambda_100$ represent the same fuzzy subgroup in (2) and (3).

Summing up all these we obtain $175+351+64+104+48+24+32+16+16=703$.

Thus the group $G = \mathbf{Z}_{p^2} + \mathbf{Z}_q + \mathbf{Z}_{r^2}$ has $703 = 2^{2+1} \left[\frac{(2)^3}{2} + 13 \times \frac{(2)^2}{2} + 21(2) + 16 \right] - 1$

distinct fuzzy subgroups.

Illustration Two: The group $G = \mathbf{Z}_{p^3} + \mathbf{Z}_q + \mathbf{Z}_{r^2}$

Next we determine the number of fuzzy subgroups for the case $n = 3$, that is the group $G = \mathbf{Z}_{p^3} + \mathbf{Z}_q + \mathbf{Z}_{r^2}$. We use the lattice diagram of subgroups below to carry-out pin extensions from the eight base nodes :

$p^3qr, p^2qr, pqr, p^3r, p^2r, pr, qr$ and r .

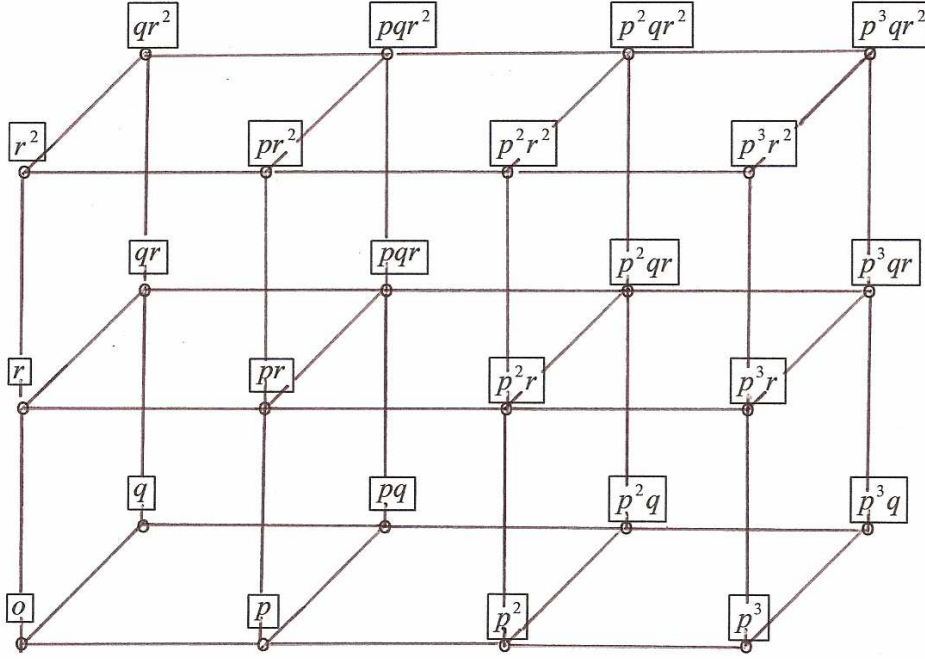

Node p^3qr : applying Proposition 5.4.2 we have $2^{3+1}[3^2 + 6(3) + 6] - 1$ non-equivalent fuzzy subgroups. We know that the number of fuzzy subgroups, if viewed as keychains, with a non-zero pin-end is one more than the number of fuzzy subgroups viewed as keychains, ending with a zero pin. Thus we have

$\frac{1}{2}[2^4(3^2 + 6(3) + 6) - 1 + 1]$ distinct fuzzy subgroups ending with nonzero pin and

$\frac{1}{2}[2^4(3^2 + 6(3) + 6)] - 1$ fuzzy subgroups ending with a zero pin. Keychains in p^3qr

are of the form $1\lambda_1\lambda_2\lambda_3\lambda_4\lambda_5$, for $1 \geq \lambda_1 \geq \lambda_2 \geq \lambda_3 \geq \lambda_4 \geq \lambda_5 \geq 0$. Now with $\lambda_5 \neq 0$ we can only extend to fuzzy subgroups $1\lambda_1\lambda_2\lambda_3\lambda_4\lambda_5\lambda_5$, $1\lambda_1\lambda_2\lambda_3\lambda_4\lambda_5\lambda_6$ and

$1\lambda_1\lambda_2\lambda_3\lambda_4\lambda_5 0$ in p^3qr . Thus $\frac{1}{2}[2^4(3^2 + 6(3) + 6) - 1 + 1]$ becomes

$\frac{1}{2}[2^4(3^2 + 6(3) + 6)] \times 3$ and $\frac{1}{2}[2^4(3^2 + 6(3) + 6)] - 1$ remains the same. The total for

this node thus becomes $\frac{1}{2}[2^4(3^2 + 6(3) + 6)] \times 4 - 1 = 1055$

Node p^3r : from Theorem 3.2.18 we obtain $2^4(3 + 2) = 80$ distinct fuzzy subgroups of which half will have nonzero pin-ends. We extend through the following

route $p^3r \rightarrow p^3r^2 \rightarrow p^3qr^2$. Keychains in p^3r are of the form $1\lambda_1\lambda_2\lambda_3\lambda_4$, for $1 \geq \lambda_1 \geq \lambda_2 \geq \lambda_3 \geq \lambda_4 \geq 0$. Now for $\lambda_4 \neq 0$ we can only extend to the following keychains $1\lambda_1\lambda_2\lambda_3\lambda_4\lambda_4\lambda_4, 1\lambda_1\lambda_2\lambda_3\lambda_4\lambda_4\lambda_5, 1\lambda_1\lambda_2\lambda_3\lambda_4\lambda_5\lambda_5, 1\lambda_1\lambda_2\lambda_3\lambda_4\lambda_5\lambda_6, 1\lambda_1\lambda_2\lambda_3\lambda_4\lambda_40, 1\lambda_1\lambda_2\lambda_3\lambda_4\lambda_50$ and $1\lambda_1\lambda_2\lambda_3\lambda_400$ in the subgroup p^3qr^2 . We note that the keychains $1\lambda_1\lambda_2\lambda_3\lambda_4\lambda_50, 1\lambda_1\lambda_2\lambda_3\lambda_4\lambda_5\lambda_6, 1\lambda_1\lambda_2\lambda_3\lambda_4\lambda_40$ and $1\lambda_1\lambda_2\lambda_3\lambda_4\lambda_4\lambda_5$ have not been counted when extending through the node p^3qr , and two of these have non-zero pin-ends and therefore will result in new fuzzy subgroups, while $1\lambda_1\lambda_2\lambda_3\lambda_4\lambda_40$ and $1\lambda_1\lambda_2\lambda_3\lambda_400$ do not result in any new fuzzy subgroups. The keychains $1\lambda_1\lambda_2\lambda_3\lambda_4\lambda_4\lambda_4$ and $1\lambda_1\dots\lambda_4\lambda_5\lambda_5$ represent fuzzy subgroups that have been counted when extending using node p^3qr , thus the total for the node p^3r will be

$$\frac{1}{2}[80] \times 4 = 160 \text{ distinct fuzzy subgroups.}$$

From the node p^2qr , applying proposition 5.4.2, we have

$[2^{2+1}(2^2 + 6(2) + 6)] - 1 = 175$ distinct fuzzy subgroups, and taking into account that half of the fuzzy subgroups will have non-zero pin-ends and are one more than those that end with a zero, we then have $\frac{1}{2}[2^3(2^2 + 6(2) + 6)] = 88$ distinct fuzzy subgroups

with no zero pin-ends. We will use the following route $p^2qr \rightarrow p^2qr^2 \rightarrow p^3qr^2$.

Keychains in p^2qr are of the form $1\lambda_1\lambda_2\lambda_3\lambda_4$, for $1 \geq \lambda_1 \geq \lambda_2 \geq \lambda_3 \geq \lambda_4 \geq 0$. Now for $\lambda_4 \neq 0$ we can only extend to the following keychains

$1\lambda_1\lambda_2\lambda_3\lambda_4\lambda_4\lambda_4, 1\lambda_1\lambda_2\lambda_3\lambda_4\lambda_4\lambda_5, 1\lambda_1\lambda_2\lambda_3\lambda_4\lambda_5\lambda_5, 1\lambda_1\lambda_2\lambda_3\lambda_4\lambda_5\lambda_6, 1\lambda_1\lambda_2\lambda_3\lambda_4\lambda_40,$

$1\lambda_1\lambda_2\lambda_3\lambda_4\lambda_50$ and $1\lambda_1\lambda_2\lambda_3\lambda_400$. The following four fuzzy subgroups, viewed as

keychains, have not been counted before viz $1\lambda_1\lambda_2\lambda_3\lambda_4\lambda_4\lambda_5, 1\lambda_1\lambda_2\lambda_3\lambda_4\lambda_5\lambda_6,$

$1\lambda_1\lambda_2\lambda_3\lambda_4\lambda_50$ and $1\lambda_1\lambda_2\lambda_3\lambda_4\lambda_40$ therefore we have $88 \times 4 = 352$ distinct fuzzy subgroups for this node.

Extending from the node p^2r we use the following routes

$$p^2r \rightarrow p^2r^2 \rightarrow p^3r^2 \rightarrow p^3qr^2$$

$$p^2r \rightarrow p^2r^2 \rightarrow p^2qr^2 \rightarrow p^3qr^2$$

From Proposition 3.2.18 we know that p^2r has thirty-one fuzzy subgroups of which we know that those with nonzero pin-ends are one more than those with zero pin-end, and each route above involves four nodes. Keychains in p^2r are of the form $1\lambda_1\lambda_2\lambda_3$ for $1 \geq \lambda_1 \geq \lambda_2 \geq \lambda_3 \geq 0$. Now with $\lambda_3 \neq 0$ we can only extend to the following keychains $1\lambda_1\lambda_2\lambda_3\lambda_3\lambda_3\lambda_3$, $1\lambda_1\lambda_2\lambda_3\lambda_3\lambda_3\lambda_4$, $1\lambda_1\lambda_2\lambda_3\lambda_3\lambda_4\lambda_4$, $1\lambda_1\lambda_2\lambda_3\lambda_3\lambda_4\lambda_5$, $1\lambda_1\lambda_2\lambda_3\lambda_3\lambda_5\lambda_5$, $1\lambda_1\lambda_2\lambda_3\lambda_4\lambda_4\lambda_4$, $1\lambda_1\lambda_2\lambda_3\lambda_4\lambda_5\lambda_5$, $1\lambda_1\lambda_2\lambda_3\lambda_4\lambda_5\lambda_6$, $1\lambda_1\lambda_2\lambda_3\lambda_300$, $1\lambda_1\lambda_2\lambda_3\lambda_3\lambda_40$, $1\lambda_1\lambda_2\lambda_3\lambda_4\lambda_50$, $1\lambda_1\lambda_2\lambda_3000$, $1\lambda_1\lambda_2\lambda_3\lambda_4\lambda_40$, $1\lambda_1\lambda_2\lambda_3\lambda_3\lambda_30$, $1\lambda_1\lambda_2\lambda_3\lambda_400$. Now comparing these keychains to the ones obtained when extending through the nodes p^3qr , p^3r and p^2qr and the two routes that can be used to extend, the first route will contribute $16 \times 8 = 128$ distinct fuzzy subgroups while the second contributes $\frac{1}{2}[16 \times 8] = 64$ distinct fuzzy subgroups in p^3qr^2 .

We employ a similar way of argument for the remaining base nodes and we obtain the following number of distinct fuzzy subgroups for the nodes:

$$pqr \text{ gives } 26 \times 8 = 208$$

$$pr \text{ gives } 6 \times 16 + 6 \times 8 + 6 \times 8 = 192$$

$$qr \text{ gives } 6 \times 16 = 96$$

And finally r gives $2 \times 32 + 2 \times 16 + 2 \times 16 + 2 \times 16 = 160$ (because of the four routes and five nodes in these routes)

The total for this group is $1055 + 160 + 352 + 128 + 64 + 208 + 192 + 96 + 160 = 2415$

So the group $G = \mathbf{Z}_{p^3} \times \mathbf{Z}_q \times \mathbf{Z}_{r^2}$ has $2^{3+1} \left[\frac{(3)^3}{2} + 13 \times \frac{(3)^2}{2} + 21(3) + 16 \right] - 1$ distinct

fuzzy subgroups.

Illustrations One and Two motivate proposition 5.4.4

Instead of giving a direct proof of the proposition we derive the formula in style by use of the counting technique discussed earlier on and the extensions carried out on the base nodes of the lattice diagram of subgroups. We also firstly list down formulae that we use in the proofs of propositions 5.4.4, 5.4.5 and 5.4.6

NOTE: 5.4.3.1

(a) $1 + 2 + 3 + \dots + n = \frac{n(n+1)}{2}$ for $n \in \mathbb{N}$.

(b) $1^2 + 2^2 + 3^2 + \dots + n^2 = \frac{1}{6}n(n+1)(2n+1)$ for $n \in \mathbb{N}$.

(c) $1^3 + 2^3 + 3^3 + \dots + n^3 = \frac{1}{4}n^2(n+1)^2$ for $n \in \mathbb{N}$.

(d) $1^4 + 2^4 + 3^4 + \dots + n^4 = \frac{1}{30}n(n+1)(2n+1)(3n^2 + 3n - 1)$ for $n \in \mathbb{N}$

Proposition: 5.4.4

$G = \mathbb{Z}_{p^n} + \mathbb{Z}_q + \mathbb{Z}_{r^2}$ has $2^{n+1} \left[\frac{n^3}{2} + \frac{13n^2}{2} + 21n + 16 \right] - 1$ fuzzy subgroups for all $n \geq 1$.

Proof

We use the lattice diagram below and the counting technique discussed earlier on.

Lattice Diagram Six

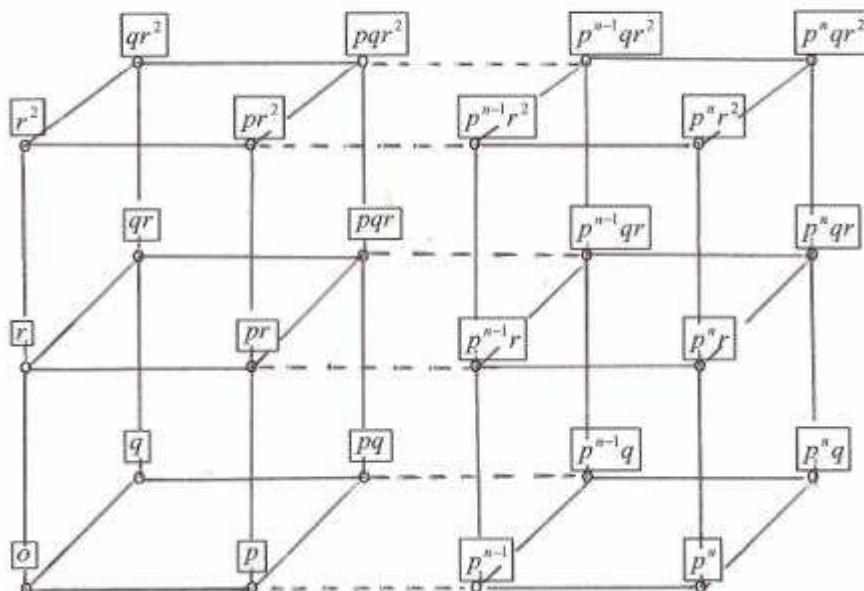

Since we know from Proposition 5.4.2 and Lemma 3.2.18 that the groups

$G = Z_{p^n} + Z_q + Z_r$ and $G = Z_{p^n} + Z_q$ have $2^{n+1}[n^2 + 6n + 6] - 1$ and $2^{n+1}(n + 2) - 1$

fuzzy subgroups for $n \geq 1$ respectively, now carrying out the extensions from the base nodes we obtain the following:

Node: $p^n qr$ gives $\frac{1}{2}[2^{n+1}(n^2 + 6n + 6)] \times 4 - 1 = 2^{n+1}(2n^2 + 12n + 12) - 1$ fuzzy

subgroups.

Node: $p^n r$ gives $\frac{1}{2}[2^{n+1}(n + 2)] \times 4 = 2^{n+2}(n + 2)$ fuzzy subgroups.

Node: $p^{n-1} qr$ gives $\frac{1}{2}[2^{n-1+1}((n-1)^2 + 6(n-1) + 6)] \times 4 = 2^{n+1}[(n-1)^2 + 6(n-1) + 6]$

fuzzy subgroups.

Node : $p^{n-1} r$ gives

$\frac{1}{2}[2^{n-1+1}((n-1) + 2)] \times 8 + \frac{1}{2}[2^{n-1+1}((n-1) + 2)] \times 4 = 2^{n+2}[n + 1] + 2^{n+1}[n + 1]$ fuzzy

subgroups.

Node $p^{n-2} qr$ gives $\frac{1}{2}[2^{n-1+1}((n-2)^2 + 6(n-2) + 6)] \times 8 = 2^{n+1}[(n-2)^2 + 6(n-2) + 6]$

Node : $p^{n-2} r$ yields

$\frac{1}{2}[2^{n-2+1}((n-2) + 2)] \times 16 + \frac{1}{2}[2^{n-2+1}((n-2) + 2)] \times 8 \times 2 = 2^{n+2}[n] + 2^{n+1}[n] \times 2$ fuzzy

subgroups.

Node : $p^{n-3} qr$ yields $\frac{1}{2}[2^{n-3+1}((n-3)^2 + 6(n-3) + 6)] \times 16 = 2^{n+1}[(n-3)^2 + 6(n-3) + 6]$

fuzzy subgroups.

Node : $p^{n-3} r$ yields

$\frac{1}{2}[2^{n-3+1}((n-3) + 2)] \times 32 + \frac{1}{2}[2^{n-3+1}((n-3) + 2)] \times 32 \times 3 = 2^{n+2}[n-1] + 2^{n+1}[n-1] \times 3$

fuzzy subgroups.

Inductively,

Node $p^3 qr$ yields $\frac{1}{2}[2^{3+1}((3)^2 + 6(3) + 6)] \times 2^{n+1-3} = 2^{n+1}[(3)^2 + 6(3) + 6]$

fuzzy subgroups.

Node : p^3r yields

$$\frac{1}{2}[2^{3+1}(3+2)] \times 2^{n-1} + \frac{1}{2}[2^{3+1}(3+2)] \times 2^{n-2} \times (n-3) = 2^{n+2}[5] + 2^{n+1}[5] \times (n-3) \text{ fuzzy}$$

subgroups.

$$\text{Node : } p^2qr \text{ yields } \frac{1}{2}[2^{2+1}((2)^2 + 6(2) + 6)] \times 2^{n+1-2} = 2^{n+1}[(2)^2 + 6(2) + 6]$$

fuzzy subgroups.

Node : p^2r yields

$$\frac{1}{2}[2^{2+1}(2+2)] \times 2^n + \frac{1}{2}[2^{2+1}(2+2)] \times 2^{n-1} \times (n-2) = 2^{n+2}[4] + 2^{n+1}[4] \times (n-2) \text{ fuzzy}$$

subgroups.

$$\text{Node : } pqr \text{ yields } \frac{1}{2}[2^{1+1}((1)^2 + 6(1) + 6)] \times 2^{n+1-1} = 2^{n+1}[(1)^2 + 6(1) + 6]$$

fuzzy subgroups.

Node : pr yields

$$\frac{1}{2}[2^{1+1}(1+2)] \times 2^{n+1} + \frac{1}{2}[2^{1+1}(1+2)] \times 2^n \times (n-1) = 2^{n+2}[3] + 2^{n+1}[3] \times (n-1) \text{ fuzzy}$$

subgroups.

$$\text{Node : } p^0qr \text{ yields } \frac{1}{2}[2^{0+1}((0)^2 + 6(0) + 6)] \times 2^{n+1-0} = 2^{n+1}[(0)^2 + 6(0) + 6]$$

fuzzy subgroups.

Node : p^0r yields

$$\frac{1}{2}[2^{0+1}(0+2)] \times 2^{n+2} + \frac{1}{2}[2^{0+1}(0+2)] \times 2^{n+1} \times (n) = 2^{n+2}[2] + 2^{n+1}[2] \times (n) \text{ fuzzy}$$

subgroups.

Now taking the sum of all these fuzzy subgroups, we obtain the following,

$$2^{n+1}[2n^2 + 12n + 12 + (n-1)^2 6(n-1) + 6 + \dots + 1^2 + 6(1) + 6 + 0^2 + 6(0) + 6] - 1$$

$$+ 2^{n+2}[(n+2) + (n+1) + (n) + \dots + 4 + 3 + 2] +$$

$$2^{n+1}[(n+1)(1) + (n)(2) + (n-1)(3) + \dots + (4)(n-2) + (3)(n-1) + (2)(n)]$$

$$= 2^{n+1} \left[n^2 + 6n + 6 + \frac{1}{6}(n)(n+1)(2n+1) + \frac{6}{2}(n)(n+1) + 6(n+1) \right] - 1$$

$$+ 2^{n+2} \left[\frac{(n+2)(n+3)}{2} - 1 \right] + \sum_{k=0}^{n-1} (2+k)(n-k)$$

Now taking the above sums separately we have

$$(a) 2^{n+1} \left[n^2 + 6n + 6 + \frac{1}{6}(n)(n+1)(2n+1) + \frac{6}{2}(n)(n+1) + 6(n+1) \right] - 1 =$$

$$2^{n+1} \left[n^2 + 6n + 6 + \frac{2n^3 + 3n^2 + n}{6} + 3n^2 + 3n + 6n + 6 \right] - 1 = 2^{n+1} \left[\frac{2n^3 + 27n^2 + 91n + 72}{6} \right] - 1$$

$$(b) 2^{n+2} \left[\frac{(n+2)(n+3)}{2} - 1 \right] = 2^{n+2} \left[\frac{n^2 + 5n + 4}{2} \right] = 2^{n+1} \left[\frac{6n^2 + 30n + 24}{6} \right]$$

$$(c) 2^{n+1} \left[\sum_{k=0}^{n-1} (2+k)(n-k) \right] = 2^{n+1} \left[\sum_{k=0}^{n-1} (2n - 2k + nk - k^2) \right]$$

$$= 2^{n+1} \left[2n(n) + (n-2) \sum_{k=0}^{n-1} k - \sum_{k=0}^{n-1} k^2 \right]$$

$$= 2^{n+1} \left[2n^2 + (n-2) \frac{1}{2}(n-1)(n) - \frac{1}{6}(n-1)(n)(2n-1) \right] \text{ (By NOTE 5.4.3.1(a) and (b))}$$

$$= 2^{n+1} \left[2n^2 + \frac{n^3 - 3n^2 + 2n}{2} - \frac{(2n^3 - 3n^2 + n)}{6} \right]$$

$$= 2^{n+1} \left[\frac{n^3 + 6n^2 + 5n}{6} \right]$$

Now adding (a), (b) and (c) we obtain:

$$2^{n+1} \left[\frac{2n^3 + 27n^2 + 91n + 72}{6} \right] + 2^{n+1} \left[\frac{6n^2 + 30n + 24}{6} \right] + 2^{n+1} \left[\frac{n^3 + 6n^2 + 5n}{6} \right] - 1$$

$$= 2^{n+1} \left[\frac{3n^3 + 39n^2 + 126n + 96}{6} \right] - 1$$

$$= 2^{n+1} \left[\frac{n^3}{2} + \frac{13n}{2} + 21n + 16 \right] - 1 \text{ fuzzy subgroups which establishes the result. } \square$$

Proposition: 5.4.5

The group $G = \mathbf{Z}_{p^n} + \mathbf{Z}_q + \mathbf{Z}_{r^3}$ has $2^{n+1} \left[\frac{n^4}{6} + \frac{23n^3}{6} + \frac{79n^2}{3} + \frac{185}{3}n + 40 \right] - 1$ fuzzy

subgroups .

Proof

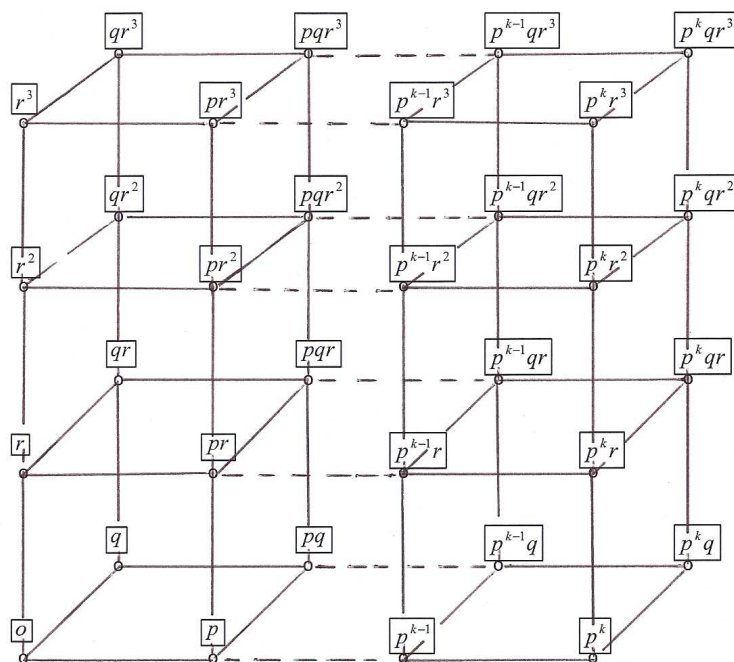

We extend from $\mathbf{Z}_{p^k} + \mathbf{Z}_q + \mathbf{Z}_{r^2}$ to $\mathbf{Z}_{p^k} + \mathbf{Z}_q + \mathbf{Z}_{r^3}$, see lattice diagram above.

The number of fuzzy subgroups of

(i) $p^k qr^2$ is $2^{k+1} \left[\frac{k^3}{2} + \frac{13}{2}k^2 + 12k + 16 \right] - 1$ for $k \geq 1$.

(ii) $p^k r^2$ is $2^{k+2+1} \sum_{n=0}^2 2^{-n} \binom{k}{m} \binom{2}{m} = 2^k [k^2 + 7k + 8]$

(iii) $p^k r$ is $2^k [k + 2]$

Now when extending, we obtain the following number of distinct fuzzy subgroups for the listed nodes;

$p^k qr^2$ yields $2^k \left[\frac{k^3}{2} + \frac{13}{2}k^2 + 21k + 16 \right] \times 4 - 1 = 2^{k+1} \times 2 \left[\frac{k^3}{2} + \frac{13}{2}k^2 + 21k + 16 \right] - 1$

$p^k r^2$ yields $2^{k-1} [k^2 + 7k + 8] \times 4 = 2^{k+1} [k^2 + 7k + 8]$

$$p^{k-1}qr^2 \text{ yields } 2^{k-1} \left[\frac{(k-1)^3}{2} + \frac{13}{2}(k-1)^2 + 21(k-1) + 16 \right] \times 4$$

$$= 2^{k+1} \left[\frac{(k-1)^3}{2} + \frac{13}{2}(k-1)^2 + 21(k-1) + 16 \right]$$

$$p^{k-1}r^2 \text{ yields } 2^{k-2} [k^2 + 7k + 8] \times 8 + 2^{k-2} [(k-1)^2 + 7(k-1) + 8] \times 4$$

$$= (2^{k+1} + 2^k) [(k-1)^2 + 7(k-1) + 8]$$

$$p^{k-2}qr^2 \text{ yields } 2^{k+1} \left[\frac{(k-2)^3}{2} + \frac{13}{2}(k-2)^2 + 21(k-2) + 16 \right]$$

$$p^{k-2}r^2 \text{ yields } (2^{k+1} + 2^k + 2^k) [(k-2)^2 + 7(k-2) + 8]$$

$$p^{k-3}r^2 \text{ yields } (2^{k+1} + 2^k + 2^k + 2^k) [(k-3)^2 + 7(k-3) + 8]$$

Inductively,

$$p^2qr^2 \text{ yields } 2^{k+1} \left[\frac{(2)^3}{2} + \frac{13}{2}(2)^2 + 21(2) + 16 \right]$$

$$p^2r^2 \text{ yields } (2^{k+1} + \underbrace{2^k + \dots + 2^k}_{k-2}) [(2)^2 + 7(2) + 8]$$

$$= (2^{k+1} + (k-2)2^k) [26] = 13 \times 2^{k+2} + 13 \times 2^k - 26 \times 2^k$$

$$pqr^2 \text{ yields } 2^{k+1} \left[\frac{(1)^3}{2} + \frac{13}{2}(1)^2 + 21(1) + 16 \right]$$

$$pr^2 \text{ yields } (2^{k+1} + (k-1)2^k) [1^2 + 7(1) + 8]$$

$$p^0qr^2 \text{ yields } 2^{k+1} \left[\frac{(0)^3}{2} + \frac{13}{2}(0)^2 + 21(0) + 16 \right]$$

$$p^0r^2 \text{ yields } (2^{k+1} + (k)2^k) [0^2 + 7(0) + 8]$$

Summing up all the fuzzy subgroups obtained above we have;

$$2^{k+1} \left[\frac{k^3}{2} + \frac{13}{2}k^2 + 21k + 16 + \frac{k^3}{2} + \frac{(k-1)^3}{2} + \dots + \frac{1^3}{2} \right]$$

$$+ 2^{k+1} \left[\frac{13}{2}(k^2 + (k-1)^2 + \dots + 1^2) + 16(k+1) \right]$$

$$+ 2^{k+1} [21(k + (k-1) + (k-2) + \dots + 1)] - 1$$

$$+ 2^{k+1} [k^2 + (k-1)^2 + \dots + 1^2 + 7(k + (k-1) + \dots + 1) + 8(k+1)]$$

$$+ 2^k [(k-1)^2 + \dots + 2^2 + 1^2] + 7((k-1) + \dots + 2 + 1) + 8k]$$

$$\begin{aligned}
& + 2^k \left[((k-2)^2 + \dots + 1^2) + 7((k-2) + \dots + 2 + 1) + 8(k-1) \right] \\
& + 2^k \left[((k-3)^2 + \dots + 2^2 + 1^2) + 7((k-3) + \dots + 2 + 1) + 8(k-3) \right] \\
& + 2^k \left[((k-4)^2 + \dots + 2^2 + 1^2) + 7((k-4) + \dots + 1) + 8(k-4) \right] \\
& + 2^k \left[(3^2 + 2^2 + 1^2) + 7(3+2+1) + 8(4) \right] \\
& + 2^k \left[(2^2 + 1^2) + 7(2+1) + 8(3) + 1^2 + 7(1) + 8(2) + 0^2 + 7(0) + 8 \right] = \\
& 2^{k+1} \left[\frac{k^3}{2} + \frac{13}{2}k^2 + 21k + 16 + \frac{13}{2} \times \frac{1}{6}k(k+1)(2k+1) + \frac{1}{2} \times \frac{1}{4}k^2(k+1)^2 + \frac{21}{2}k(k+1) + 16k + 16 \right] - 1 \\
& + \\
& 2^{k+1} \left[\frac{1}{6}k(k+1)(2k+1) + \frac{7}{2}k(k+1) + 8k + 8 \right] + 2^k \left[\frac{1}{6}(k-1)k(2k-1) + \frac{7}{2}(k-1)k + 8k + \frac{1}{6}(k-2)(k-1)(2k-3) \right] \\
& + 2^k \left[\frac{1}{6}(k-3)(k-2)(2k-5) + \frac{7}{2}(k-3)(k-2) + 8k - 16 + \dots + \right] \\
& + 2^k \left[\frac{1}{6}(2)(3)(5) + \frac{7}{2}(2)(3) + 8(3) + 1 + 7 + 8(2) + 8 \right]
\end{aligned}$$

Now taking the above terms separately and applying definition 5.4.3.1 we obtain:

$$\begin{aligned}
\text{(a)} \quad & 2^{k+1} \left[\frac{k^3}{2} + \frac{13}{2}k^2 + 21k + 16 + \frac{13}{2} \times \frac{1}{6}k(k+1)(2k+1) \right] \\
& + 2^{k+1} \left[\frac{1}{2} \times \frac{1}{4}k^2(k+1)^2 + \frac{21}{2}k(k+1) + 16k + 16 \right] - 1 \\
& = 2^{k+1} \left[\frac{k^3}{2} + \frac{13}{2}k^2 + 21k + 16 + \frac{13}{12}(2k^3 + 3k^2 + k) \right] \\
& \quad + 2^{k+1} \left[\frac{1}{8}(k^4 + 2k^3 + k^2) + \frac{21}{2}(k^2 + k) + 16k + 16 \right] - 1 \\
& = 2^{k+1} \left[\frac{3k^4 + 70k^3 + 489k^2 + 1166k + 768}{24} \right] - 1 \\
\text{(b)} \quad & 2^{k+1} \left[\frac{1}{6}k(k+1)(2k+1) + \frac{7}{2}(k(k+1) + 8k + 8) \right] = 2^{k+1} \left[\frac{2k^3 + 10k^2 + 56k + 48}{6} \right] \\
& = 2^{k+1} \left[\frac{8k^3 + 96k^2 + 280k + 192}{24} \right]
\end{aligned}$$

$$\begin{aligned}
& \text{(c) } 2^k \left[\frac{1}{6}(k-1)k(2k-1) + \frac{7}{2}(k-2)k + 8k + \frac{1}{6}(k-2)(k-1)(2k-3) \right] + \\
& + 2^k \left[\frac{1}{6}(k-3)(k-2)(2k-5) + \frac{7}{2}(k-3)(k-2) + 8k - 16 + \dots + \right] \\
& + 2^k \left[\frac{1}{6}(2)(3)(5) + \frac{7}{2}(2)(3) + 8(3) + 1 + 7 + 8(2) + 8 \right] \\
& = 2^{k+1} \left[\frac{1}{24}(k^4 - 2k^3 + k^2) + \frac{1}{24}(2k^3 - 3k^2 + k) + \frac{1}{24}k^2 - \frac{1}{24}k \right] \\
& + 2^{k+1} \left[\frac{7}{24}(2k^3 - 3k^2 + k) + \frac{7}{8}(k^2 - k) + 2k^2 + 2k \right] \\
& = 2^{k+1} \left[\frac{k^4 + 14k^3 + 47k^2 + 34k}{24} \right]
\end{aligned}$$

Now adding (a) ,(b) and (c) we obtain

$$\begin{aligned}
& 2^{k+1} \left[\frac{3k^4 + 70k^3 + 489k^2 + 1166k + 768}{24} \right] - 1 \\
& + 2^{k+1} \left[\frac{8k^3 + 96k^2 + 280k + 192}{24} \right] + 2^{k+1} \left[\frac{k^4 + 14k^3 + 47k^2 + 34k}{24} \right] \\
& = 2^{k+1} \left[\frac{4k^4 + 92k^3 + 632k^2 + 1480k + 960}{24} \right] \\
& = 2^{k+1} \left[\frac{1}{6}k^4 + \frac{23}{6}k^3 + \frac{79}{3}k^2 + \frac{185}{3}k + 40 \right] - 1
\end{aligned}$$

Thus the group $G = \mathbf{Z}_{p^k} + \mathbf{Z}_q + \mathbf{Z}_{r^3}$ has $2^{k+1} \left[\frac{1}{6}k^4 + \frac{23}{6}k^3 + \frac{79}{3}k^2 + \frac{185}{3}k + 40 \right] - 1$

distinct fuzzy subgroups. □

Proposition: 5.4.6

The group $G = \mathbf{Z}_{p^n} + \mathbf{Z}_q + \mathbf{Z}_{r^4}$ has $2^{n+1} \left[\frac{n^5}{4!} + \frac{3}{2}n^4 + \frac{431}{24}n^3 + \frac{261}{3}n^2 + \frac{331}{2}n + 96 \right] - 1$

distinct fuzzy subgroups.

Proof

Consider the following lattice diagram of subgroups of G .

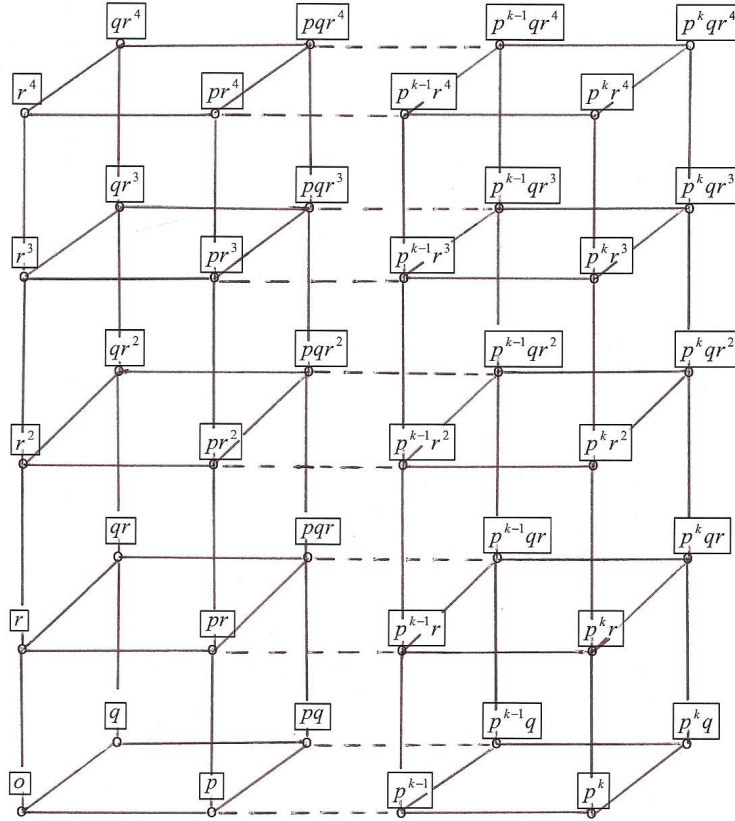

We extend from $G = \mathbf{Z}_{p^k} + \mathbf{Z}_q + \mathbf{Z}_{r^3}$ which has

$$2^{k+1} \left[\frac{1}{6}k^4 + \frac{23}{6}k^3 + \frac{79}{3}k^2 + \frac{185}{3}k + 40 \right] - 1 \text{ distinct fuzzy subgroups and}$$

$$G = \mathbf{Z}_{p^k} + \mathbf{Z}_{r^3} \text{ has } 2^{k+3=1} \sum_{r=0}^3 2^{-m} \binom{k}{m} \binom{3}{m} - 1 = 2^{k+1} \left[\frac{1}{6}k^3 + \frac{5}{2}k^2 + \frac{28}{3}k + 8 \right] - 1$$

From the lattice diagram above we carry out extensions on the base nodes and obtain the following:

$$\begin{aligned} \text{Node } p^k q r^3 \text{ has } & 2^k \left[\frac{1}{6}k^4 + \frac{23}{6}k^3 + \frac{79}{3}k^2 + \frac{185}{3}k + 40 \right] \times 4 - 1 \\ & = 2^{k+2} \left[\frac{1}{6}k^4 + \frac{23}{6}k^3 + \frac{79}{3}k^2 + \frac{185}{3}k + 40 \right] - 1 \\ & = 2^{k+2} \left[\frac{1}{2}k^3 + \frac{5}{2}k^2 + \frac{28}{3}k + 8 \right] \end{aligned}$$

$$\text{Node } p^{k-1}qr^3 \text{ has } 2^{k-1} \left[\frac{1}{6}(k-1)^4 + \frac{23}{6}(k-1)^3 + \frac{79}{3}(k-1)^2 + \frac{185}{3}(k-1) + 40 \right] \times 4$$

$$= 2^{k+1} \left[\frac{1}{6}(k-1)^4 + \frac{23}{6}(k-1)^3 + \frac{79}{3}(k-1)^2 + \frac{185}{3}(k-1) + 40 \right]$$

$$\text{Node } p^{k-1}r^3 \text{ has } 2^{k-1} \left[\frac{1}{6}(k-1)^3 + \frac{5}{2}(k-1)^2 + \frac{28}{3}(k-1) + 8 \right] \times 8$$

$$+ 2^{k-1} \left[\frac{1}{6}(k-1)^3 + \frac{5}{2}(k-1)^2 + \frac{28}{3}(k-1) + 8 \right] \times 4$$

$$= (2^{k+2} + 2^{k+1}) \left[\frac{1}{6}(k-1)^3 + \frac{5}{2}(k-1)^2 + \frac{28}{3}(k-1) + 8 \right]$$

$$\text{Node } p^{k-2}qr^3 \text{ has } 2^{k+1} \left[\frac{1}{6}(k-2)^4 + \frac{23}{6}(k-2)^3 + \frac{79}{3}(k-2)^2 + \frac{185}{3}(k-2) + 40 \right]$$

$$\text{Node } p^{k-2}r^3 \text{ has } (2^{k+2} + 2^{k+1} \times 2) \left[\frac{1}{6}(k-2)^3 + \frac{5}{2}(k-2)^2 + \frac{28}{3}(k-2) + 8 \right]$$

$$\text{Node } pqr^3 \text{ has } 2^{k+1} \left[\frac{1}{6}(1)^4 + \frac{23}{6}(1)^3 + \frac{79}{3}(1)^2 + \frac{185}{3}(1) + 40 \right]$$

$$\text{Node } pr^3 \text{ has } (2^{k+2} + 2^{k+1}(k-1)) \left[\frac{1}{6}(1)^3 + \frac{5}{2}(1)^2 + \frac{28}{3}(1) + 8 \right]$$

$$\text{Node } p^0qr^3 \text{ has } 2^{k+1} \left[\frac{1}{6}(0)^4 + \frac{23}{6}(0)^3 + \frac{79}{3}(0)^2 + \frac{185}{3}(0) + 40 \right]$$

$$\text{Node } r^3 \text{ has } (2^{k+2} + 2^{k+1}(k)) \left[\frac{1}{6}(0)^3 + \frac{5}{2}(0)^2 + \frac{28}{3}(0) + 8 \right]$$

$$\text{Now summing up we obtain } 2^{k+1} \left[\frac{k^4}{6} + \frac{23}{6}k^3 + \frac{79}{3}k^2 + \frac{185}{3}k + 40 \right]$$

$$+ 2^{k+1} \left[\frac{k^4}{6} + \frac{(k-1)^4}{6} + \dots + \frac{(1)^4}{6} + \frac{23}{6}(k^3 + (k-1)^3 + \dots + (1)^3) \right]$$

$$+ 2^{k+1} \left[\frac{79}{3}(k^2 + (k-1)^2 + \dots + (1)^2) \right] + 2^{k+1} \left[\frac{185}{6}(k + (k-1) + \dots + 1) + 40 \times (k+1) \right] - 1$$

$$+ 2^{k+2} \left[\frac{k^3}{6} + \frac{(k-1)^3}{6} + \dots + \frac{(1)^3}{6} + \frac{5}{2}(k^2 + (k-1)^2 + \dots + (1)^2) \right]$$

$$+ 2^{k+2} \left[\frac{28}{3} (k+9k-1) + \dots + 1 \right] + 8k + 8 \left] + 2^{k+1} \sum_{r=0}^{k-1} (k-r) \left[\frac{r^3}{6} + \frac{5}{2} r^2 + \frac{28}{3} r + 8 \right]$$

Using Note 5.4.3.1 (a), (b) (c) and (d) on this sum we obtain,

$$\begin{aligned} & 2^{k+1} \left[\frac{k^4}{6} + \frac{23}{6} k^3 + \frac{79}{3} k^2 + \frac{185}{3} k + 40 \right] + 2^{k+1} \left[\frac{1}{6 \times 30} (6k^5 + 25k^4 + 10k^3 - k) \right] \\ & + 2^{k+1} \left[\frac{23}{24} (k^4 + 2k^3 + k^2) + \frac{79}{18} (2k^3 + 3k^2 + k) \right] \\ & + 2^{k+1} \left[\frac{1}{6 \times 30} (k^2 + k) + 40(k+1) \right] \\ & + 2^{k+1} \left[\frac{1}{12} (k^4 + 2k^3 + k^2) + \frac{5}{6} (2k^3 + 3k^2 + k) + \frac{28}{3} (k^2 + k) + 16(k+1) + 8k^2 \right] + \\ & 2^{k+1} \left[\frac{k}{24} (k^4 - 2k^3 + k^2) + \frac{5k}{12} (2k^3 - 3k^2 + k) + \frac{28k}{6} (k^2 - k) - \frac{1}{180} (6k^5 - 15k^4 + 10k^3 - k) \right] \\ & - 2^{k+1} \left[\frac{5}{8} (k^4 - 2k^3 + k^2) + \frac{28}{18} (2k^3 - 3k^2 + k) + \frac{8}{2} (k^2 - k) \right] - 1 \end{aligned}$$

Taking these brackets separately we get the following sums

$$\begin{aligned} \text{(i)} & 2^{k+1} \left[\frac{k^4}{6} + \frac{23}{6} k^3 + \frac{79}{3} k^2 + \frac{185}{3} k + 40 + \frac{1}{180} [6k^5 + 15k^4 + 10k^3 - k] \right] \\ & + 2^{k+1} \left[\frac{23}{24} [k^4 + 2k^3 + k^2] \right] + 2^{k+1} \left[\frac{79}{18} \left[2k^3 + 3k^2 + k + \frac{185}{12} (k^2 + k) \right] \right] \\ & + 2^{k+1} [40k + 40] - 1 \\ & = 2^{k+1} \left[\frac{k^5}{30} + \frac{435}{360} k^4 + \frac{2625}{12} k^3 + \frac{16955}{360} k^2 + \frac{43728}{360} k + 80 \right] - 1 \\ \text{(ii)} & 2^{k+2} \left[\frac{k^3}{6} + \frac{(k-1)^3}{6} + \dots + \frac{(1)^3}{6} + \frac{5}{2} (k^2 + (k-1)^2 + \dots + (1)^2) \right] \\ & + 2^{k+2} \left[\frac{28}{3} (k+9k-1) + \dots + 1 + 8k^2 \right] \\ & = 2^{k+2} \left[\frac{k^4}{24} + \frac{22k^3}{12} + \frac{239k^2}{24} + \frac{157}{12} k + 8 \right] = 2^{k+1} \left[\frac{k^4}{12} + \frac{22k^3}{6} + \frac{239k^2}{12} + \frac{157}{6} k + 16 \right] \\ \text{(iii)} & 2^{k+1} \left[\sum_{r=0}^{k-1} (k-r) \left[\frac{r^3}{6} + \frac{5}{2} r^2 + \frac{28}{3} r + 8 \right] \right] = 2^{k+1} \left[\frac{k^5}{120} + \frac{5k^4}{24} - \frac{293k^3}{360} + \frac{7195k^2}{360} + \frac{6432}{360} k \right] \end{aligned}$$

Adding (i), (ii) and (iii) we obtain:

$$2^{k+1} \left[\frac{15k^5 + 540k^4 + 6265k^3 + 31320k^2 + 59580k + 34560}{360} \right] - 1$$

$$= 2^{k+1} \left[\frac{k^5}{4!} + \frac{3}{2}k^4 + \frac{431}{24}k^3 + \frac{261}{3}k^2 + \frac{331}{2}k + 96 \right] - 1.$$

Thus the group $G = \mathbf{Z}_{p^k} + \mathbf{Z}_q + \mathbf{Z}_{r^3}$ has

$$2^{n+1} \left[\frac{n^5}{4!} + \frac{3}{2}n^4 + \frac{431}{24}n^3 + \frac{261}{3}n^2 + \frac{331}{2}n + 96 \right] - 1 \text{ distinct fuzzy subgroups.} \quad \square$$

5.5 Conclusion

Research on the study of equivalence classes of fuzzy subgroups of groups has generated a lot of interest amongst a number of researchers as mentioned in the main introduction. The counting technique we have been studying can be continued to find the number of distinct fuzzy subgroups of $Z_{p^n} + Z_{q^m} + Z_{r^s}$ where p, q and r are distinct primes. Thus if the number of distinct fuzzy subgroups of $G_1 = Z_{p^n} + Z_{q^m} + Z_{r^{s-1}}$ is known, then the technique discussed in this thesis may be used to find the number of distinct fuzzy subgroups of $G = Z_{p^n} + Z_{q^m} + Z_{r^s}$ (or $G = Z_{p^{n+1}} + Z_{q^m} + Z_{r^{s-1}}$ or $G = Z_{p^n} + Z_{q^{m+1}} + Z_{r^{s-1}}$). We illustrate this when $n = 2, m = 2$ and $s = 2$ because in the thesis we have had one of n, m and s as 1 all the time. Thus $G_1 = Z_{p^2} + Z_{q^2} + Z_r$ is a group whose number of fuzzy subgroups is known, and we want to compute the number of distinct fuzzy subgroups of the group $G = Z_{p^2} + Z_{q^2} + Z_{r^2}$. We construct a lattice diagram for G and use the lattice diagram for G_1 within G to compute the number required.

By Proposition 5.4.4, G_1 has $2^{2+1} \left[\frac{2^3}{2} + \frac{13(2)^2}{2} + 21 \times 2 + 16 \right] - 1 = 8[88] - 1 = 703$

distinct fuzzy subgroups.

The following is the lattice diagram for $G = Z_{p^2} + Z_{q^2} + Z_{r^2}$.

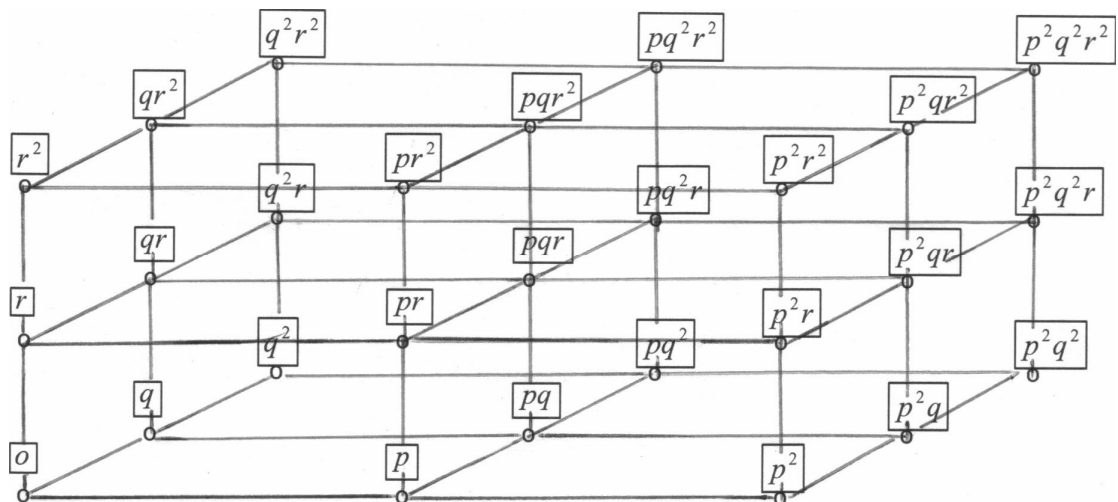

We use the lattice diagram for p^2qr^2 and extend the number of distinct fuzzy subgroups of p^2qr^2 using the following nodes : p^2qr^2 , p^2qr , p^2q , pq , pqr , pqr^2 , q , qr and qr^2 . Note that p^2q^2r and p^2qr^2 have the same number of distinct fuzzy subgroups, thus using p^2qr^2 is as good as using p^2q^2r .

We begin with the node p^2qr^2 which has 703 distinct fuzzy subgroups. Now we know that $\frac{1}{2}[703 + 1] = 352$ of the fuzzy subgroups viewed as keychains end with a nonzero pin and we extend to one node, thus p^2qr^2 contributes $352 \times 4 - 1 = 1407$ distinct fuzzy subgroups. Node p^2qr , from Proposition 5.4.2 has 175 distinct fuzzy subgroups. Keychains in p^2qr extend to seven more keychains in $p^2q^2r^2$ because there are three nodes. Out of the seven, four will result in new fuzzy subgroups if viewed as key chains, thus p^2qr will contribute $\frac{1}{2}[175 + 1] \times 4 = 352$ distinct fuzzy subgroups in $p^2q^2r^2$.

The subgroup p^2q has, from Lemma 3.2.1, $2^{2+1}[2 + 2] - 1 = 31$ distinct fuzzy subgroups, its contribution in $p^2q^2r^2$ will be $\frac{1}{2}[31 + 1] \times 8 = 128$ distinct fuzzy subgroups. Here we multiply by eight because of the four nodes used in the extension.

Next we extend from node pqr^2 . From proposition 5.4.2 and using symmetry, pqr^2 has 175 distinct fuzzy subgroups. We extend through this route

$pqr^2 \rightarrow pq^2r^2 \rightarrow p^2q^2r^2$. There are seven three pin extensions here and four will give rise to new fuzzy subgroups in $p^2q^2r^2$, thus the contribution of this node is

$$\frac{1}{2}[176] \times 4 = 352 \text{ fuzzy subgroups.}$$

Node pqr , from proposition 5.4.2, has 51 fuzzy subgroups. Extending from this node we use the following routes: $pqr \rightarrow pq^2r \rightarrow p^2q^2r \rightarrow p^2q^2r^2$ (a)

$$pqr \rightarrow pq^2r \rightarrow pq^2r^2 \rightarrow p^2q^2r^2 \text{ (b)}$$

We know that 26 fuzzy subgroups viewed as keychains end with a non-zero pin and from the routes above there are four nodes through which we can extend. So pqr

from route (a) contributes $\frac{1}{2}[52] \times 8 = 208$ fuzzy subgroups and through route (b)

contribute $\frac{1}{2} \times \frac{1}{2}[52] \times 8 = 104$ fuzzy subgroups.

Node pq has eleven distinct fuzzy subgroups, six will give rise to new fuzzy subgroups. We then observe that there are three routes through which we can extend namely:

$$pq \rightarrow pq^2 \rightarrow pq^2r \rightarrow pq^2r^2 \rightarrow p^2q^2r^2 \quad (a)$$

$$pq \rightarrow pq^2 \rightarrow pq^2r \rightarrow p^2q^2r \rightarrow p^2q^2r^2 \quad (b)$$

$$pq \rightarrow pq^2 \rightarrow p^2q^2 \rightarrow p^2q^2r \rightarrow p^2q^2r^2 \quad (c)$$

So the total contribution of pq using route (a) is $6 \times 16 = 96$ distinct fuzzy subgroups.

The sixteen is a result of the five nodes used. Through route (b) we have

$\frac{1}{2}[6 \times 16] = 48$ distinct fuzzy subgroups. Route (c) gives an equal number of fuzzy

subgroups because pq^2r and pq^2r^2 are distinguishing factors for the second and third route respectively.

Node qr^2 , from Lemma 3.2.1 and by symmetry, has 31 distinct fuzzy subgroups, of these 16 end with a non-zero pin-end. We can only extend through the following route

$qr^2 \rightarrow q^2r^2 \rightarrow pq^2r^2 \rightarrow p^2q^2r^2$, so qr^2 contributes $\frac{1}{2}[31+1] \times 8 = 128$ distinct

fuzzy subgroups

Node qr has eleven distinct fuzzy subgroups. We extend through the three routes. viz

$$qr \rightarrow q^2r \rightarrow q^2r^2 \rightarrow pq^2r^2 \rightarrow p^2q^2r^2$$

$$qr \rightarrow q^2r \rightarrow pq^2r \rightarrow pq^2r^2 \rightarrow p^2q^2r^2$$

$$qr \rightarrow q^2r \rightarrow pq^2r \rightarrow p^2q^2r \rightarrow p^2q^2r^2$$

and five nodes, so qr contributes $\frac{1}{2}[11+1] \times 16 = 96$ distinct fuzzy subgroups when

considering the first route, and $\frac{1}{2} \times \frac{1}{2}[11+1] \times 16 = 48$ distinct fuzzy subgroups for

each of the last two routes.

Finally we compute those distinct fuzzy subgroups obtained when extending from the subgroup q . By theorem 3.2.11, Z_{p^n} for $n = 1$, has $2^{1+1} - 1 = 3$ distinct fuzzy

subgroups. Two end with a nonzero pin. There are six routes to extend through, viz:

$$q \rightarrow q^2 \rightarrow q^2 r \rightarrow q^2 r^2 \rightarrow pq^2 r^2 \rightarrow p^2 q^2 r^2$$

$$q \rightarrow q^2 \rightarrow q^2 r \rightarrow pq^2 r \rightarrow pq^2 r^2 \rightarrow p^2 q^2 r^2$$

$$q \rightarrow q^2 \rightarrow pq^2 \rightarrow pq^2 r \rightarrow pq^2 r^2 \rightarrow p^2 q^2 r^2$$

$$q \rightarrow q^2 \rightarrow q^2 r \rightarrow pq^2 r \rightarrow p^2 q^2 r \rightarrow p^2 q^2 r^2$$

$$q \rightarrow q^2 \rightarrow pq^2 \rightarrow pq^2 r \rightarrow p^2 qr^2 \rightarrow p^2 q^2 r^2$$

$$q \rightarrow q^2 \rightarrow pq^2 \rightarrow p^2 q^2 \rightarrow p^2 q^2 r \rightarrow p^2 q^2 r^2$$

Now through the first route q will contribute $\frac{1}{2}[2] \times 32 = 32$ distinct fuzzy subgroups.

The remaining five routes will each result in q contributing $\frac{1}{2}[2 \times 32] = 32$ distinct fuzzy subgroups.

Summing all we obtain $1407 + 352 + 128 + 352 + 312 + 192 + 128 + 96 + 48 + 48 + 224 = 3287$ distinct fuzzy subgroups for the group $G = Z_{p^2} \times Z_{q^2} \times Z_{r^2}$.

Now as a way of verifying the number 3287, we use $pq^2 r^2$ to extend from. Clearly $pq^2 r^2$ has 703 distinct fuzzy subgroups. For extension to $p^2 q^2 r^2$ we use the following nodes: $pq^2 r^2$, $pq^2 r$, pqr^2 , pqr , pq^2 , pq , pr^2 , pr and p .

We now give a summarized count of the number of fuzzy subgroups obtained when we extend from the subgroup $pq^2 r^2$ to $p^2 q^2 r^2$.

Node $pq^2 r^2$ yields $\frac{1}{2}[704] \times 4 - 1 = 1407$ fuzzy subgroups.

Node $pq^2 r$ yields $\frac{1}{2}[176] \times 4 = 352$

Node pqr^2 yields $\frac{1}{2}[176] \times 4 = 352$

Node pq^2 yields $\frac{1}{2}[32] = 128$ fuzzy subgroups.

Node pqr : We can extend through the following two routes:

$$pqr \rightarrow p^2qr \rightarrow p^2qr^2 \rightarrow p^2q^2r^2 \text{ (a)}$$

$$pqr \rightarrow p^2qr \rightarrow p^2q^2r \rightarrow p^2q^2r^2 \text{ (b)}$$

So (a) is assigned all subgroups as distinguishing factors, thus yields

$$\frac{1}{2}[52] \times 8 = 208 \text{ fuzzy subgroups. (b) contributes } \frac{1}{2} \times \frac{1}{2}[52] \times 8 = 104 \text{ as } p^2q^2r$$

distinguishes it from (a).

Node pq : We extend through the following three routes:

$$pq \rightarrow p^2q \rightarrow p^2qr \rightarrow p^2q^2r \rightarrow p^2q^2r^2 \text{ (1)}$$

$$pq \rightarrow p^2q \rightarrow p^2q^2 \rightarrow p^2q^2r \rightarrow p^2q^2r^2 \text{ (2)}$$

$$pq \rightarrow p^2q \rightarrow p^2qr \rightarrow p^2qr^2 \rightarrow p^2q^2r^2 \text{ (3)}$$

Route (1) contributes $\frac{1}{2}[12] \times 16 = 96$ fuzzy subgroups, route (2) contributes

$$\frac{1}{2^2}[12] \times 16 = 48 \text{ fuzzy subgroups as } p^2q^2 \text{ distinguishes it from (1) and route (3)}$$

contributes $\frac{1}{2^2}[12] \times 16 = 48$ fuzzy subgroups as subgroup p^2qr^2 distinguishes it from

(1).

Node pr^2 yields $\frac{1}{2}[32] \times 8 = 128$ fuzzy subgroups.

Node pr : We use the following three routes :

$$pr \rightarrow p^2r \rightarrow p^2r^2 \rightarrow p^2qr^2 \rightarrow p^2q^2r^2 \text{ (a)}$$

$$pr \rightarrow p^2r \rightarrow p^2qr \rightarrow p^2qr^2 \rightarrow p^2q^2r^2 \text{ (b)}$$

$$pr \rightarrow p^2r \rightarrow p^2qr \rightarrow p^2q^2r \rightarrow p^2q^2r^2 \text{ (c)}$$

Using propositions 5.2.4, 5.2.5 and 5.2.6 , (a) contributes $\frac{1}{2}[12] \times 16 = 96$ fuzzy

subgroups. It is also clear that the subgroup p^2qr , distinguishes (b) from (a) , thus

route (b) contributes $\frac{1}{2^2}[12] \times 16 = 48$ fuzzy subgroups and because of the subgroup

p^2q^2r (c) contributes $\frac{1}{2^2}[12] \times 16 = 48$ distinct fuzzy subgroups.

Node p : We extend using the following six routes :

$$p \rightarrow p^2 \rightarrow p^2r \rightarrow p^2r^2 \rightarrow p^2qr^2 \rightarrow p^2q^2r^2$$

$$p \rightarrow p^2 \rightarrow p^2 r \rightarrow p^2 q r \rightarrow p^2 q r^2 \rightarrow p^2 q^2 r^2$$

$$p \rightarrow p^2 \rightarrow p^2 r \rightarrow p^2 q r \rightarrow p^2 q^2 r \rightarrow p^2 q^2 r^2$$

$$p \rightarrow p^2 \rightarrow p^2 q \rightarrow p^2 q r \rightarrow p^2 q r^2 \rightarrow p^2 q^2 r^2$$

$$p \rightarrow p^2 \rightarrow p^2 q \rightarrow p^2 q r \rightarrow p^2 q^2 r \rightarrow p^2 q^2 r^2$$

$$p \rightarrow p^2 \rightarrow p^2 q \rightarrow p^2 q^2 \rightarrow p^2 q^2 r \rightarrow p^2 q^2 r^2$$

If we assign $\frac{1}{2}[4] \times 32 = 64$ fuzzy subgroups to the first route (as a maximal chain),

each of the last five routes has a factor or two that distinguishes it from the first,

therefore they have a combined contribution of $5 \times \frac{1}{2}[4] \times 32 = 160$ fuzzy subgroups.

Now summing up we obtain

$1407+352+352+208+104+128+96+48+48+128+96+48+48+64+160=3287$ distinct fuzzy subgroups for the group $G = \mathbf{Z}_{p^2} + \mathbf{Z}_{q^2} + \mathbf{Z}_{r^2}$. This number is the same as the one obtained when we extended using $p^2 q r^2$.

The arguments used in chapter five can also be used to compute the number of fuzzy subgroups of $G = \mathbf{Z}_{p_1^{n_1}} + \mathbf{Z}_{p_2^{n_2}} + \dots + \mathbf{Z}_{p_k^{n_k}}$ where all the p_i 's are distinct primes,

although the lattice diagrams may be too complicated since for example in

$G = \mathbf{Z}_{p_1^{n_1}} + \mathbf{Z}_{p_2^{n_2}} + \mathbf{Z}_{p_3^{n_3}} + \mathbf{Z}_{p_4^{n_4}}$ we need a 4-dimensional diagram. Hence it may be

necessary to explore other techniques of computing the number of distinct fuzzy subgroups. Ngcibi in [31] studied p-groups of rank 2 and only managed to get a recurrence formula for the number of distinct fuzzy subgroups, suggesting the complexity of such computations.

LIST OF DIAGRAMS

Figure 1

Figure One

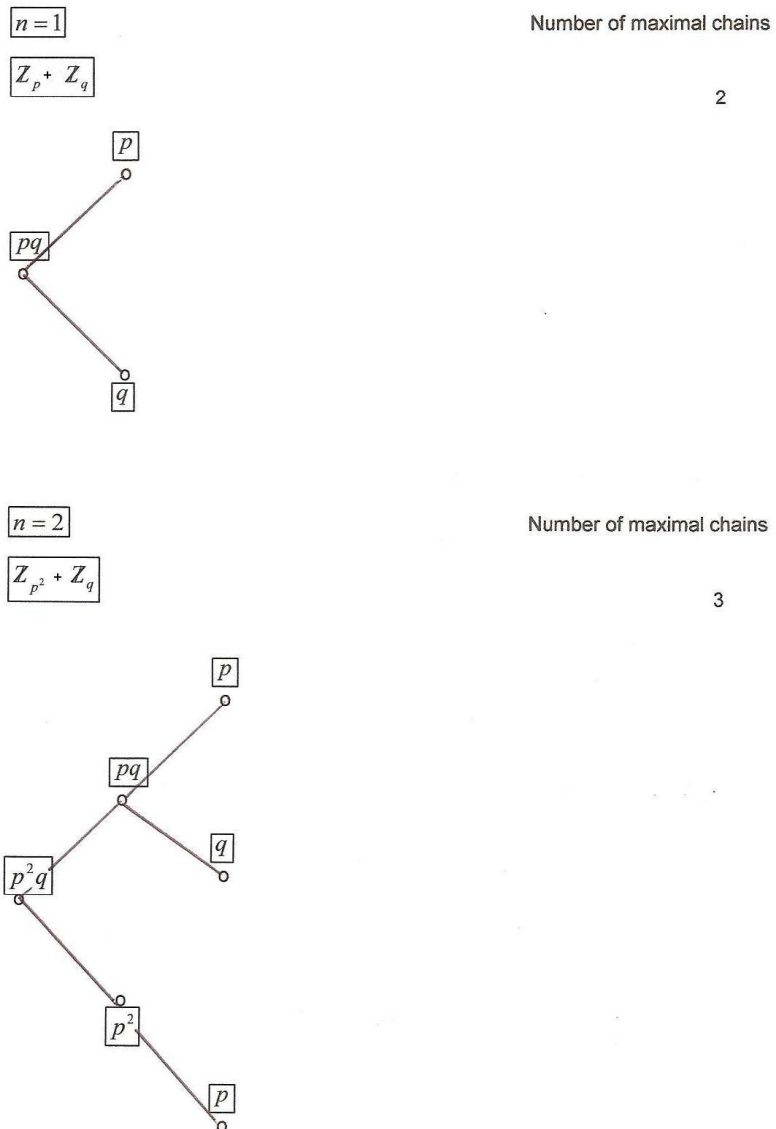

Figure Two

$$n = 3$$

$$\mathbb{Z}_{p^3} + \mathbb{Z}_q$$

Number of maximal chains

4

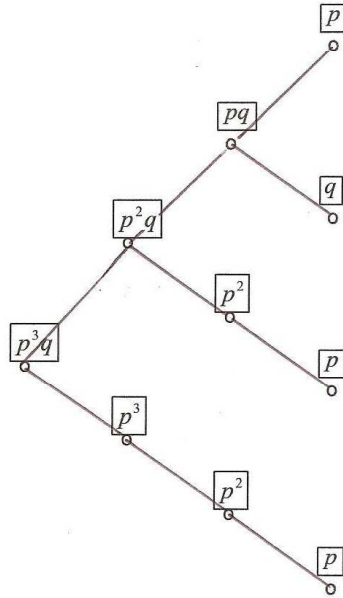

Figure Three

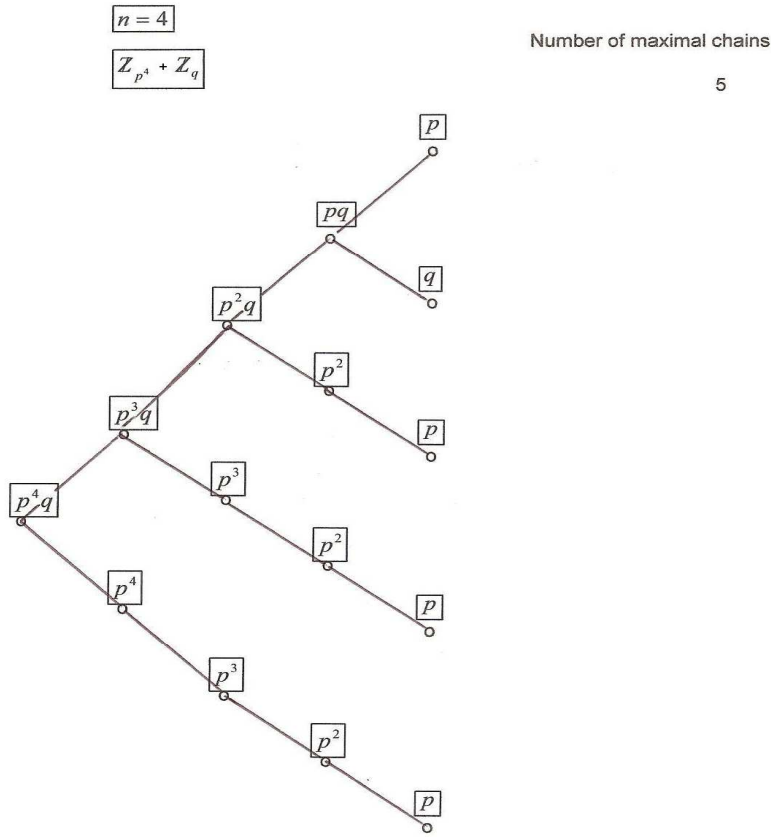
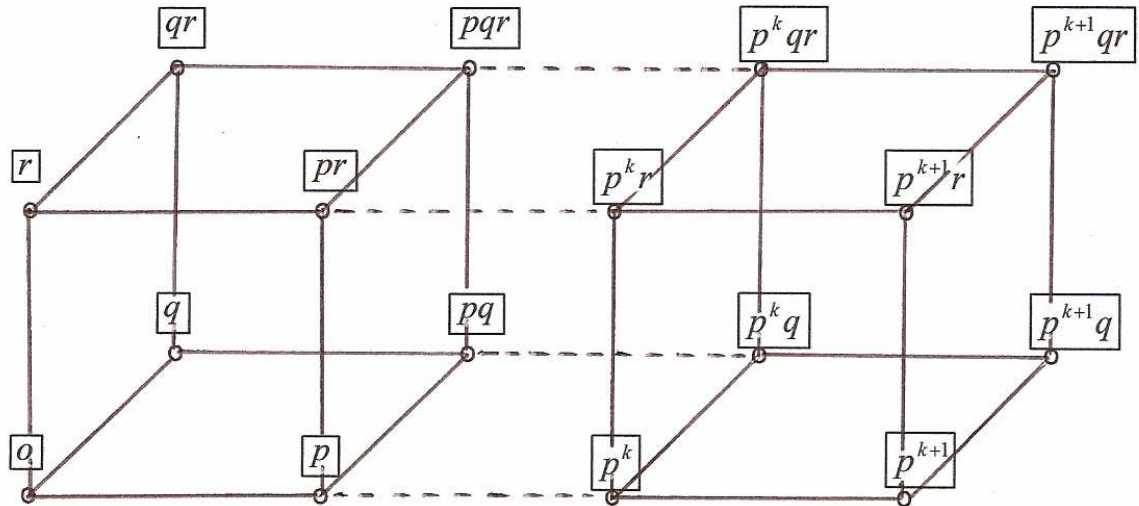
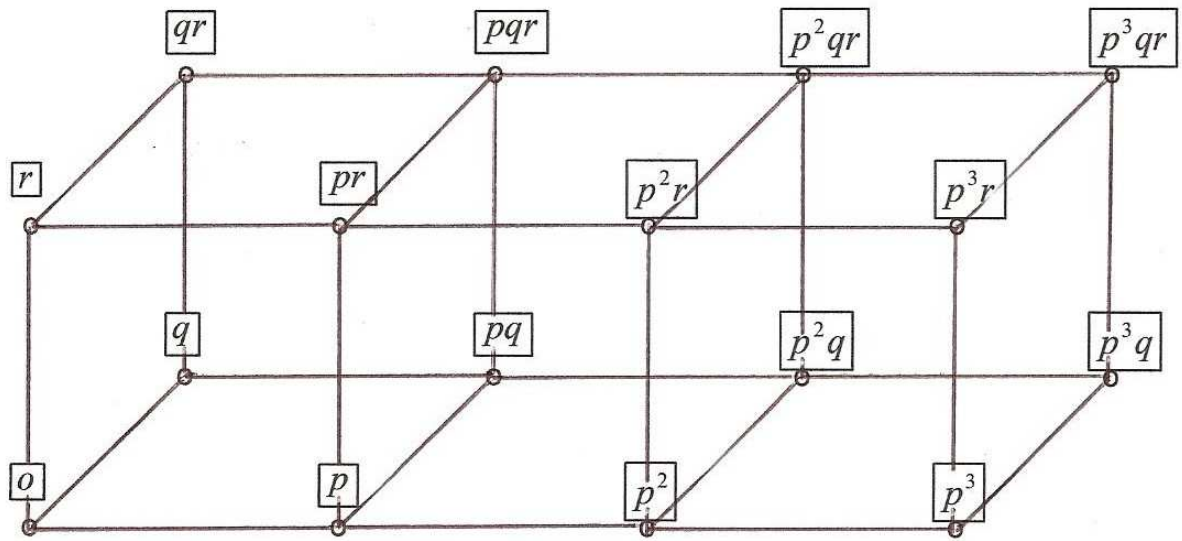

Figure 3



Lattice Diagram 1



Lattice Diagram 2

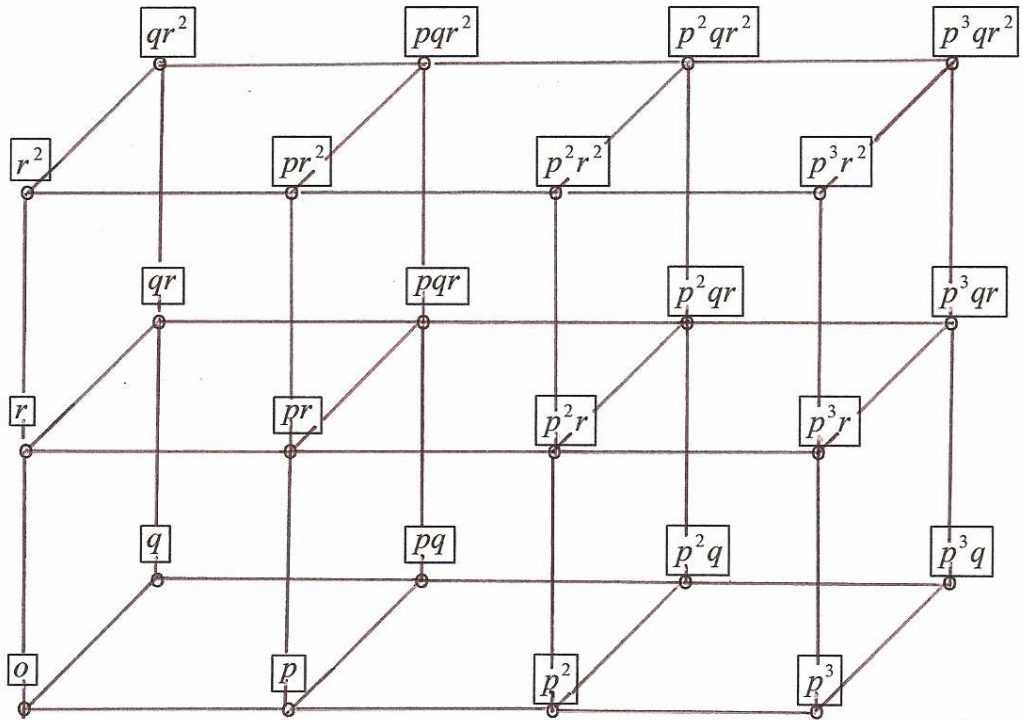

Lattice Diagram 3

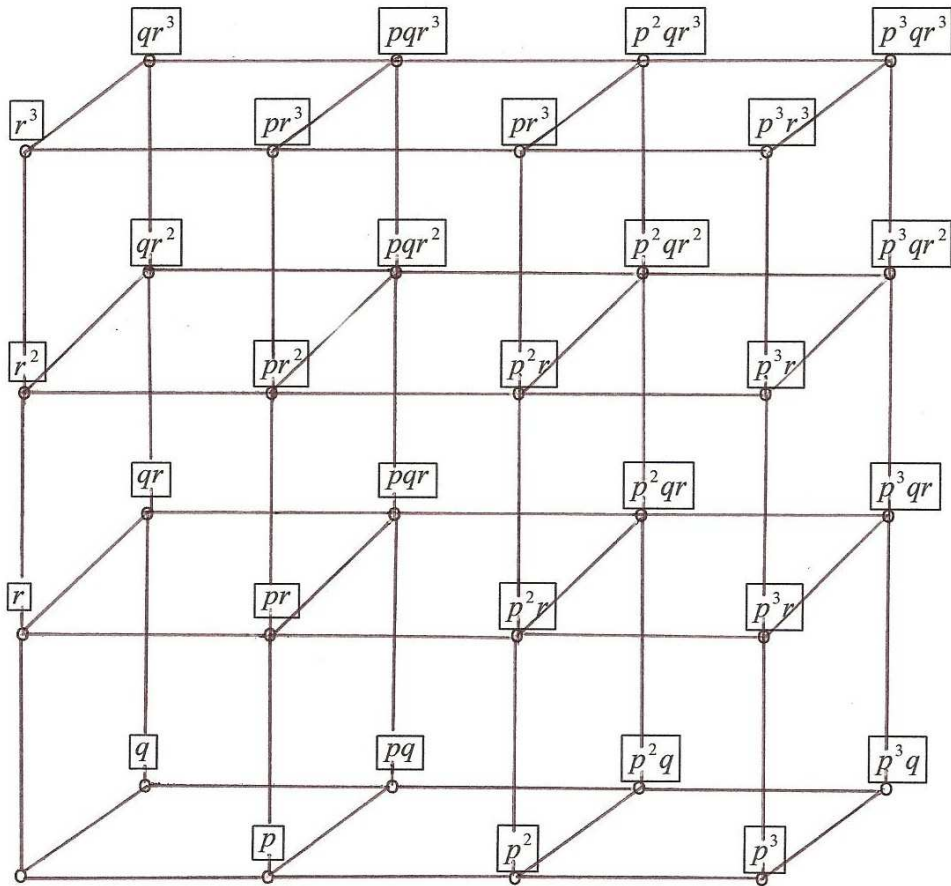

Lattice Diagram 4

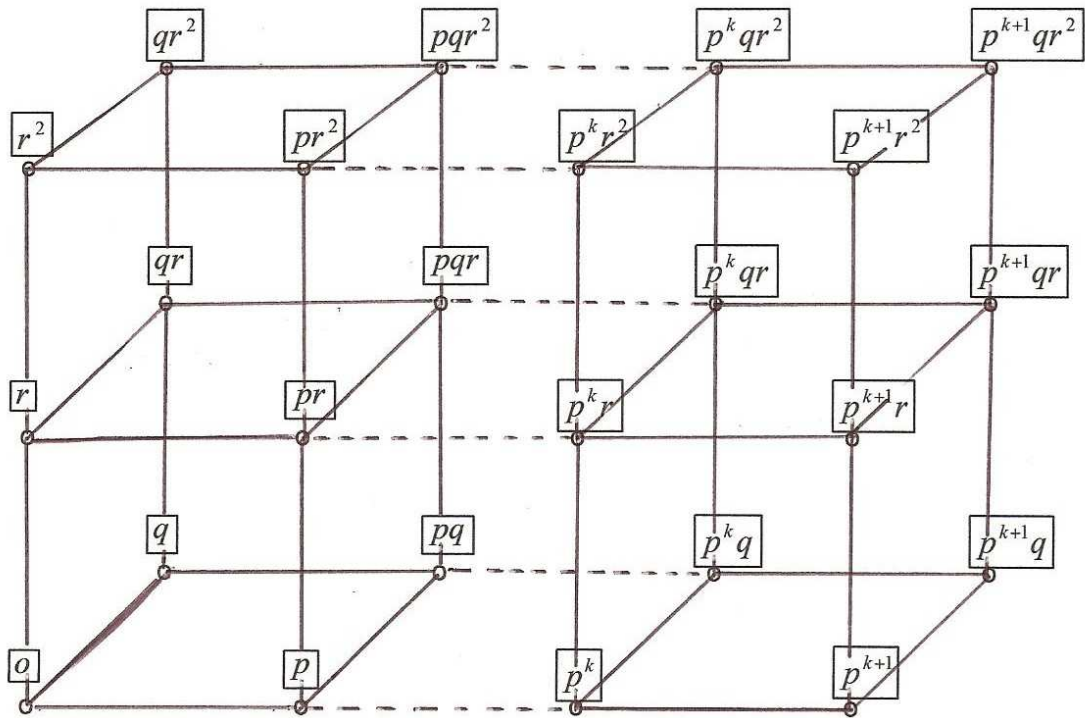

Lattice Diagram 5

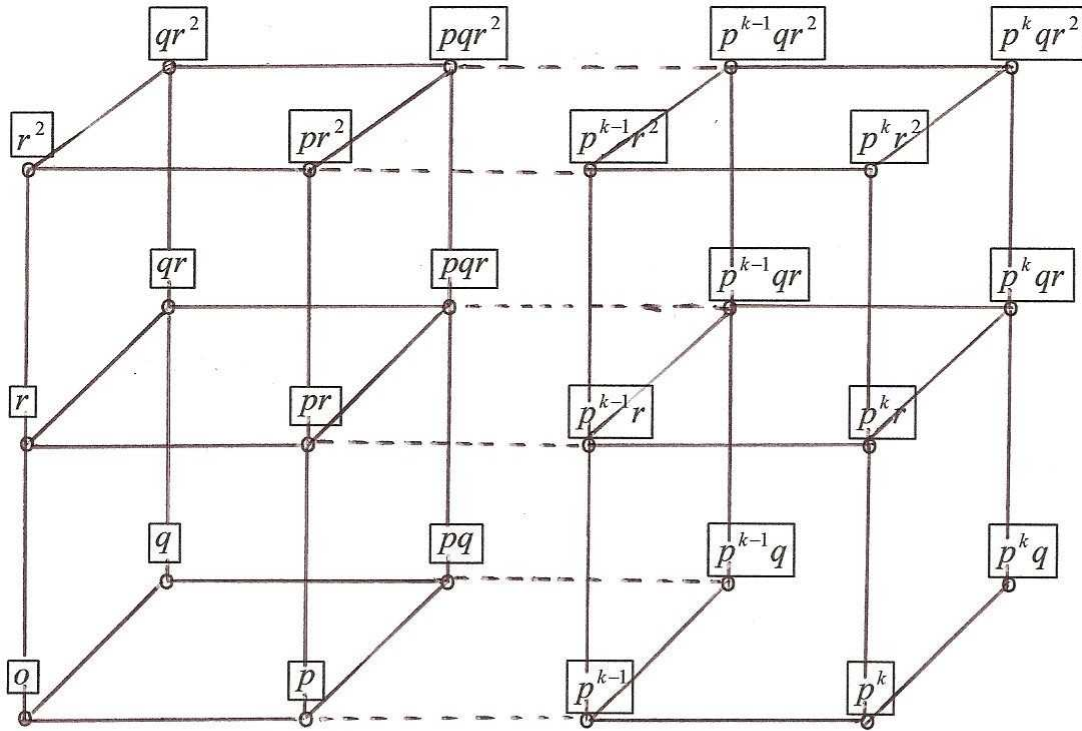

Lattice Diagram 6

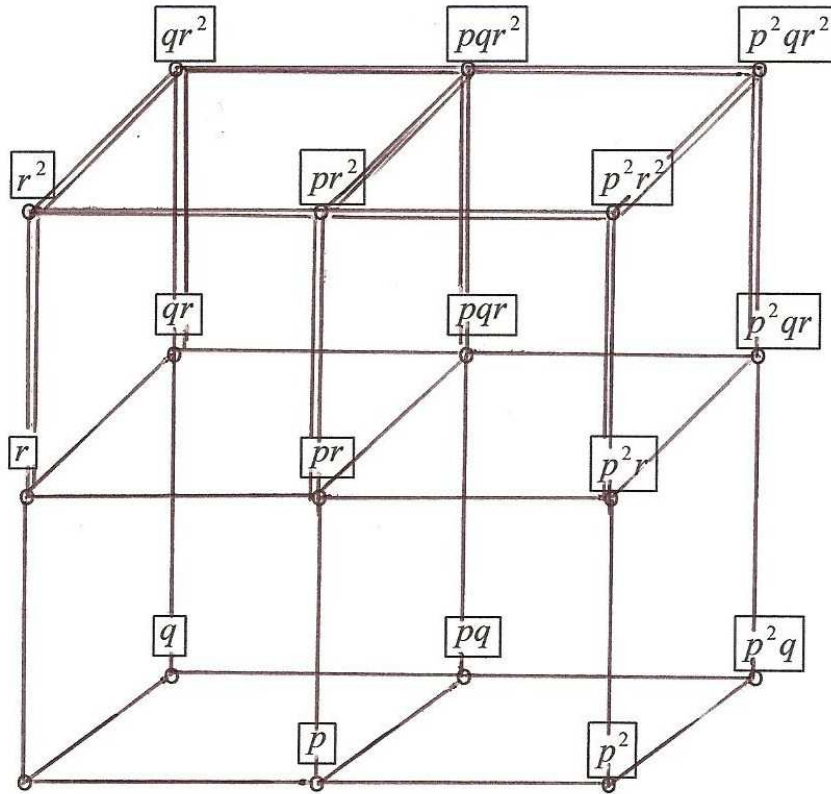

Lattice Diagram 7

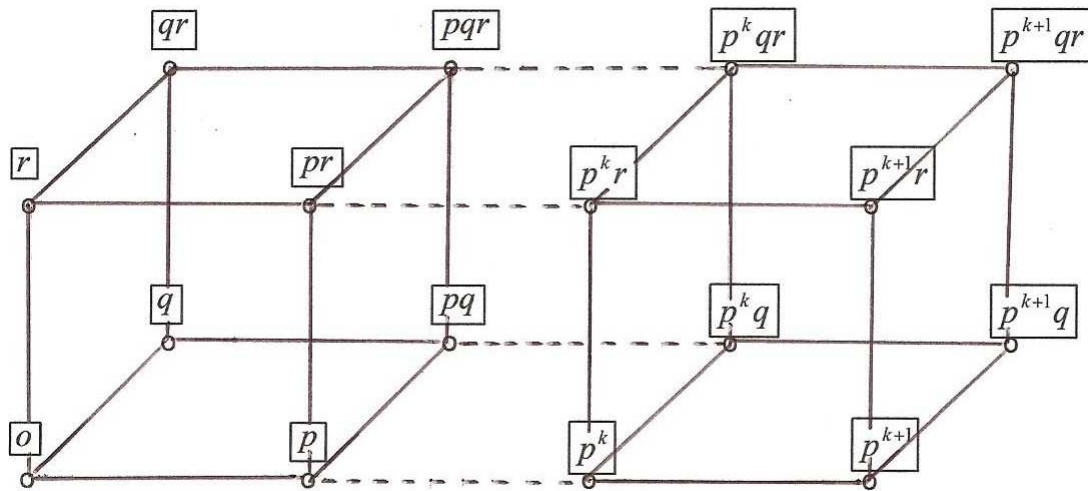

Lattice Diagram 8

REFERENCES

- [1] Salah Abou-Zaid, On Generalised Characteristic fuzzy subgroups of a finite group, FSS 43 (1991) 235-241
- [2] M.Akgul, Some properties of Fuzzy Subgroups, J.Math.Anal.Appl. 133(1988) 93-100
- [3] J.M.Anthony and H.Sherwood, Fuzzy Groups Redefined, J.Math.Anal.Appl. 69 (1979) 124-130
- [4] B.Baumslag, B.Channdler, Theory and Problems of Group Theory, McGraw-Hill, New York 1968.
- [5] P.Bhattacharya, Fuzzy subgroups. Some characterization II, Information Sciences 38 (1986) 293-297
- [6] P.Bhattacharya, Fuzzy subgroups. Some characterization, J.Math.Anal.Appl. 128(1987) 241-252
- [7] P.Bhattacharya , N.P.Mukherjee, Fuzzy Relations and Fuzzy Groups, Information Sciences 36 (1985) 267-282
- [8] D.Boixader, Some Properties Concerning the Qursi-inverse of a t-norm, Mathsware and soft Computing 5 (1998) 5-12
- [9] M.K.Chakraborty, M.Das, Studies in Fuzzy relations over fuzzy subsets, FSS 9 (1983) 79-89
- [10] M.K.Chakraborty, M.Das, On equivalence II , FSS 11 (1983) 299-307
- [11] P.S.Das, Fuzzy groups and level subgroups, J.Math.Anal.Appl.84(1981)264-269
- [12] A.De Luca , S.Termini, Algebraic Properties of Fuzzy Sets, J.Maths.Analy. and Appl.40 (1970) 373-386
- [13] J.B.Fraleigh, A First Course in Abstract Algebra, Addison-Wesley, London 1982
- [14] F.Formato, G.Gerla, L.Scarpati, Fuzzy subgroups and similarities, Soft Computing 3 (1999) 1-6
- [15] Frednard Gedion, A Study of Fuzzy Sets and Systems with application to Group theory and decision making, Thesis, Rhodes University 2005.
- [16] A.Kaufmann, Introduction to the Theory of Fuzzy Subsets. Fundamental Theoretical Elements, Volume 1 Academic Press Incl.1975.

- [17] Jae-Gyeom Kim, Lattices of fuzzy subgroupoids, Fuzzy submonoids and Fuzzy subgroups, Information Sciences 19 (1996) 77-93.
- [18] G.J.Klir, T. A.Folyer, Fuzzy sets, Uncertainty and information, Prentice-Hall Internatinal(UK) Limited Incl.1988.
- [19] R.Kumar, Homomorphism and Fuzzy normal subgroups, FSS 44(1991) 165-168.
- [20] B.B.Makamba, Studies in Fuzzy Groups, Thesis, Rhodes University, Grahamstown (1992).
- [21] B.B. Makamba, Direct products and Isomorphisms of fuzzy subgroups, Information Sciences 65 (1992) 33-43.
- [22] BB Makamba ,V.Murali, Normality and Congruence in Fuzzy Subgroups, Information Sciences 59 (1992) 121-129.
- [23] N.P.Mkherjee, P.Bhattacharya, Fuzzy groups:Some Group Theoretic Analogs, Inform.Sci.39 (1986) 247-268.
- [24] V.Murali, Fuzzy Equivalence Relations, FSS 30 (1989) 155-163
- [25] V.Murali , B.B. Makamba, On an equivalence of fuzzy subgroups I, Fuzzy Sets and Systems 123 (2001) 259-264
- [26] V.Murali, B.B.Makamba, On an equivalence of fuzzy subgroups II, Fuzzy Sets and Systems 136(2003) 93-104.
- [27] V.Murali, B.B.Makamba, On an equivalence of fuzzy subgroups III, IJMM 36 (2003) 2303-2313.
- [28] V.Murali, B.B.Makamba, Counting the number of subgroups of an abelian group of order $p^n q^m$, Fuzzy Sets and Systems 144 (2004) 459-470.
- [29] V.Murali, B.B.Makamba, Fuzzy subgroups of abelian groups, Far East J.Math.Sci. (FEJM) 14(1) (2004) 113-125.
- [30] S.Ngcibi, Case Studies of equivalent fuzzy subgroups of finite abelian groups, Thesis, Rhodes University, Grahamstown (2001).
- [31] S.Ngcibi, Studies of equivalent fuzzy subgroups of abelian p-groups of rank two and their subgroup lattices, Phd Thesis, Rhodes University 2005.
- [32] M.Pruszyriska, M.Dudzicz, On isomorphism between Finite Chains, Journal of Formalised Mathematics 12 (2003) 1-2.
- [33] S.Ray, Isomorphic Fuzzy Groups II, FSS 50 (1992) 201-207

- [34] A.Rosenfeld, Fuzzy Groups, J.Math.Analy.Appl. 35 (1971) 512-517.
- [35] J.J.Rotman, An Introduction to the Theory of Groups, 3rd Ed, Wm.C.Brown Publishers, 1988.
- [36] J.Riordan, An Introduction to Combinatorial Analysis, New York, John Wily and Sons 1958
- [37] S.Sebastian , S.B.Sunder, Fuzzy groups and group homomorphisms, FSS 81 (1996) 397-401
- [38] H.Sherwood, Product of Fuzzy subgroups, FSS 11 (1983) 79-89.
- [39] L.A.Zadeh, Fuzzy Sets, Information and Control 8 (1965) 338-353.
- [40] L.A.Zadeh, Similarity relations and fuzzy orderings, Information Sciences 3 (1971) 177-200
- [41] H.J.Zimmermann, Fuzzy Set Theory-and Its Applications, 3rd Ed., Kluwer-Nijhoff Publishing,1988 .