

North Carolina Agricultural and Technical State University
Aggie Digital Collections and Scholarship

Theses

Electronic Theses and Dissertations

2014

Hvac Supply Air Optimization Using Evolutionary Algorithms

Tony Van Nguyen

North Carolina Agricultural and Technical State University

Follow this and additional works at: <https://digital.library.ncat.edu/theses>

Recommended Citation

Nguyen, Tony Van, "Hvac Supply Air Optimization Using Evolutionary Algorithms" (2014). *Theses*. 230.
<https://digital.library.ncat.edu/theses/230>

This Thesis is brought to you for free and open access by the Electronic Theses and Dissertations at Aggie Digital Collections and Scholarship. It has been accepted for inclusion in Theses by an authorized administrator of Aggie Digital Collections and Scholarship. For more information, please contact iyanna@ncat.edu.

HVAC Supply Air Optimization Using Evolutionary Algorithms

Tony Van Nguyen

North Carolina A&T State University

A thesis submitted to the graduate faculty

in partial fulfillment of the requirements for the degree of

MASTER OF SCIENCE

Department: Civil, Architectural, and Environmental Engineering

Major: Civil Engineering

Major Professor: Dr. Nabil Nassif

Greensboro, North Carolina

2014

The Graduate School
North Carolina Agricultural and Technical State University
This is to certify that the Master's Thesis of

Tony Van Nguyen

has met the thesis or requirements of
North Carolina Agricultural and Technical State University

Greensboro, North Carolina
2014

Approved by:

Dr. Nabil Nassif
Major Professor

Dr. Sameer Hamoush
Department Chair

Dr. Manoj Jha
Committee Member

Dr. Stephanie Luster-Teasley
Committee Member

Dr. Sanjiv Sarin
Dean, The Graduate School

Biographical Sketch

Tony Nguyen is a native to Cherryville, North Carolina where he first went to University of North Carolina at Charlotte. He went to Cherryville High School and graduated in 2002. After many years of many major changes, traveling along the East coast, and having lived in Florida and Washington, DC for several internships he became more interested in trying something more academically creative. He then went to NC A&T State University to try Architectural Engineering in 2008, and it became simply one of his most memorable decisions. Originally he intended to develop his more creative side, however he found himself very intrigued with the mechanical engineering aspects of building construction and this led me to HVAC. He never imagined himself involved in HVAC design and operations but continued his given talent and interest. Throughout the years, he got to attend much internships such as North Carolina Department of Energy, The Washington Center, and US Coast Guard Headquarters. At the same time, he wanted to simultaneously start paying back my school loans which led him to join the Army National Guard of North Carolina in September 2009. After graduating with his bachelors in 2011 and acquiring my engineering E.I.T. certification in April 2012. He quickly entered the Masters of Science in Civil Engineering program at the same school which was interrupted late 2012 and quickly mobilized out to Egypt with 5th Battalion, 113th Field Artillery. With 425 people they were sent for a peace operation to preserve the Egypt-Israel Peace Treaty of 1979 and Operation Enduring Freedom. He returned back in Fall 2013 to continue the develop of his thesis. His hobbies are comedy, cooking, and taking many trips as possible up to Blue Ridge Parkway, NC.

Dedication

This page is simply dedicated to two people- my Mom and Dad, I love you guys so much for giving me the encouragement to go to college, find myself, give back, and do great things. Nothing could ever replace the courage of having to leave your homeland of Vietnam in 1979- thinking back on this gives more than any motivation to ever succeed and work harder in life.

Acknowledgements

I would like to acknowledge my school for its great program and the professors who make it possible. Teaching isn't always an easy job, having partially experienced that myself as a graduate Teaching Assistant. I would like to thank Dr. Nabil Nassif, Robert Powell, and Dr. Sameer Hamoush for always trying to support my research at times when funding was low. Your vast knowledge has always left me humbled and with a sense of humility to learn more.

Table of Contents

List of Figures	ix
List of Tables	x
Abstract	2
CHAPTER 1 Introduction.....	3
1.1 Overview.....	3
1.2 Problem Statement.....	3
1.3 Energy Conservation and Building Standards	4
1.4 Scope.....	4
1.5 Research Objectives.....	6
1.6 Limitations	6
1.7 General Description--Air Side Distribution.....	7
1.8 General Description--Variable Air Volume	8
CHAPTER 2 Literature Review	11
2.1 Introduction.....	11
2.2 Optimization of HVAC Control Systems Strategy using G.A	12
2.3 Optimized Supply-Air Temperature (SAT) in Variable Air Volume Systems	13
2.4 A Model-Based Optimal Ventilation Control Strategy of Multi-Zone VAV Air- Conditioning Systems	14
2.5 Summary.....	17
CHAPTER 3 Building Load Development.....	20
3.1 Introduction.....	20
3.2 eQuest Building Simulation.....	20
3.3 Load Extraction	24

CHAPTER 4 Optimization Model.....	26
4.1 Introduction.....	26
4.2 Genetic Algorithm Description.....	26
4.3 MATLAB- Optimtool for Genetic Algorithm.....	28
4.4 Variable Air Volume Model.....	29
CHAPTER 5 Results and Analysis of Optimization and Setpoints.....	36
5.1 Introduction	36
5.2 Peak-Load	36
5.2.1 Peak Load- Supply Air Temperature.....	39
5.2.2 Peak Load- Supply Air Pressure.....	39
5.3 Partial-Load	40
5.3.1 Partial Load- Supply Air Temperature.....	40
5.3.2 Partial Load- Supply Air Pressure.....	41
5.4 Energy Analysis Summary	42
5.4.1 Ventilation Rates: ASHRAE 62.1.....	43
5.4.2 Peak versus Partial Load	43
5.4.3 Optimized versus Non-Optimized Setpoints: Genetic Algorithm.....	43
5.5 Fan Laws.....	45
5.6 Outside Air Ventilation.....	47
CHAPTER 6 Conclusion	48
6.1 Introduction.....	48
6.2 Constraints & Boundaries.....	48
6.3 Application	50
6.4 Future Research	51

References.....	53
Appendix A: eQuest Data	57
Appendix B: HVAC Model	60
Appendix C: VAV Model.....	61
Appendix D: Optimization Using ASHRAE 62.1-2003 Peak Load, July 15th.....	65
Appendix E: Optimization Using ASHRAE 62.1-2013 Peak Load, July 15th	66
Appendix F: Optimization Using ASHRAE 62.1-2013 Partial Load, April 10th	67

List of Figures

Figure 1. Optimization Process.....	5
Figure 2. General Schematic of Supply Air Control System.....	8
Figure 3. Diagram of the Dynamic Multi-Zone Ventilation Equation Scheme.....	15
Figure 4. Developing a Baseline for Building Design Load in eQuest..	21
Figure 5. Interior Space Zoning of Buildings Layout.....	22
Figure 6. HVAC Mechanical Equipment Selection	23
Figure 7. eQuest Overall Air-Side System Selection.....	24
Figure 8. eQuest Baseline Design Data..	25
Figure 9. General Genetic Algorithm Model.....	27
Figure 10. Optimization Model Organization and Processes	30
Figure 11. Different Zones Showing Varying Amounts of Loads.....	37
Figure 12. Building Loads Throughout the Day.....	37
Figure 13. Optimtool Simulation Sample for 8:00am	38
Figure 14. Supply Air Temperature- Optimized, ASHRAE 62.1-2013 at Peak Load.....	39
Figure 15. Supply Air Pressure- Optimized, ASHRAE 62.1-2013 at Peak Load	40
Figure 16. Supply Air Temperature- Optimized, ASHRAE 62.1-2013 at Partial Load.....	41
Figure 17. Supply Air Pressure- Optimized, ASHRAE 62.1-2013 at Partial Load.....	41
Figure 18. Actual Energy Demand	42
Figure 19. Psychometric of Outside Air's Effect on Mixed Air and Enthalpy.....	46
Figure 20. VAV System Model Airflow Constraint.....	49
Figure 21. HVAC Model Constraint Summary at Peak Load	49

List of Tables

Table 1 Building Design Data Extracted from eQuest	25
Table 2 NOAA Climatic Data for Greensboro, NC for Partial and Peak Cooling Day	31
Table 3 ASHRAE 62.1-1989 to 2003 Table for Outside Air Ventilation	33
Table 4 ASHRAE 62.1-2004 to 2013 Table for Outside Air Ventilation	34

Abstract

Heating, ventilation, and air-conditioning account for a vast majority of energy consumption in the residential and commercial sectors. Intelligent energy management control system (EMCS) in buildings offers an excellent means of reducing energy consumption in heating, ventilation, and air-conditioning (HVAC) systems while maintaining or improving indoor environmental conditions. This can be achieved through the use of computational intelligence and optimization. This project proposes and evaluates a model-based optimization process for HVAC systems using an evolutionary algorithm. The process can be integrated into the EMCS to perform several intelligent functions and achieve optimal whole-system performance. The proposed process addresses the requirements of the latest ASHRAE Standard 62.1. A whole building simulation energy software is used to generate the sub hourly load. The simulations are performed to test the process and determine the potential energy savings achieved. In addition, simulations were conducted at peak load on July 15th and partial load on April 10th to observe the effects of genetic algorithm (GA).

Through artificial intelligence utilization, the energy consumption can be better managed. Building controls are like living organisms which can be treated much like evolutionary biology during programming. The single-objective GA optimization and modernized ventilation codes have demonstrated that total energy consumed by the HVAC system can be reduced by 30.6% for the air side distribution.

CHAPTER 1

Introduction

1.1 Overview

The intent of this research is to develop an intelligent strategy using technology to drop energy consumption and evaluate a model-based optimization process for HVAC systems using GA. In this chapter, the issue of why energy conservation is in such high demand among buildings is discussed, along with a reflection on some of the guidelines that buildings are required to meet nowadays. Other points discussed are the HVAC system is also discussed, the impact of its setpoints on energy conservation, and how technology can be used to lower energy consumption.

1.2 Problem Statement

According to the U.S. Energy Information Administration, the building load is ever increasing due to human and environmental factors. Several other notable HVAC statistics include commercial spaces which account for 50% of fuel consumption by end use, space heating alone accounts for 36% of consumption, and facility HVAC systems account for 62% of non-process energy consumption by end use within manufacturing industry (Energy Information Administration [EIA], 2012). Both residential and commercial buildings account globally for 20- 40% of all energy consumption (Perez, 2008). While primary energy use has marginally decreased in the residential sector, it has increased 0.6% annually in commercial sector (EIA, 2012). Dehumidification is also a very energy expensive process in southern U.S. and accounts for more than 60% of the total U.S. cooling energy consumption whereas the Northeast and the Midwest regions account for approximately 10% and 12% (Dieckmann, 2009). Along with greater cooling and HVAC demand but fuel cost is also rising. With such a large amount of

energy consumption attributed to HVAC, there are much room for improving efficiency and reducing energy consumption.

1.3 Energy Conservation and Building Standards

With new innovations and standards, efficiency can be gained in many ways. The American Society of Heating, Refrigeration, and Air-Conditioning Engineers, ASHRAE, is just one of many organizations that create new standards and guidelines such ASHRAE 62.1 and 90.1 on how to implement these technologies. Furthermore, among the sustainability and energy associations including U.S. Green Building Council or Leadership in Energy and Environmental Design, American Energy Engineers, and Department of Energy, there are strong goals and mandates to lower energy consumption and integrate new technologies including building mechanical systems. Furthermore, modern building technologies currently allow better control particularly with feedback and variable responses. While many research are on areas such as economizers control strategies utilizing split control and PID control loops (Wang & Xu, 2002).

1.4 Scope

Optimization focuses on the primary goal of energy reduction. As shown in Figure 1, the three main components of the optimization are the load prediction tool, variable air volume (VAV) model, and genetic algorithm (GA). The load prediction tool, eQuest, simulates the building in an annual period to which the peak load on a particular day was selected. The software eQuest is an advanced simulator of building heat loads but also is able to simulate energy consumption and can be modified in vast case scenarios with different building codes, types, and mechanical equipment selection. The VAV algorithm and program determines a simple energy utilization using input information from eQuest and external data collection and is

the core of the optimization. It will be explained in greater depth later on in the thesis. GA mimics the evolutionary process into numerical terms in which the fittest setpoints are used in determining the supply air temperature and pressure for our model. The fittest setpoints arrives after a specified number of generations as survival of the strongest data gets carried onto the next generation. This is also another important, strong feature of the optimization as the weakest setpoint are dissolved and the program continuously cycles through random data of surviving from the prior generations along with a mutation factor. From the GA and VAV model, the energy cost is computed from three main mechanical components: fan, reheat, and chiller.

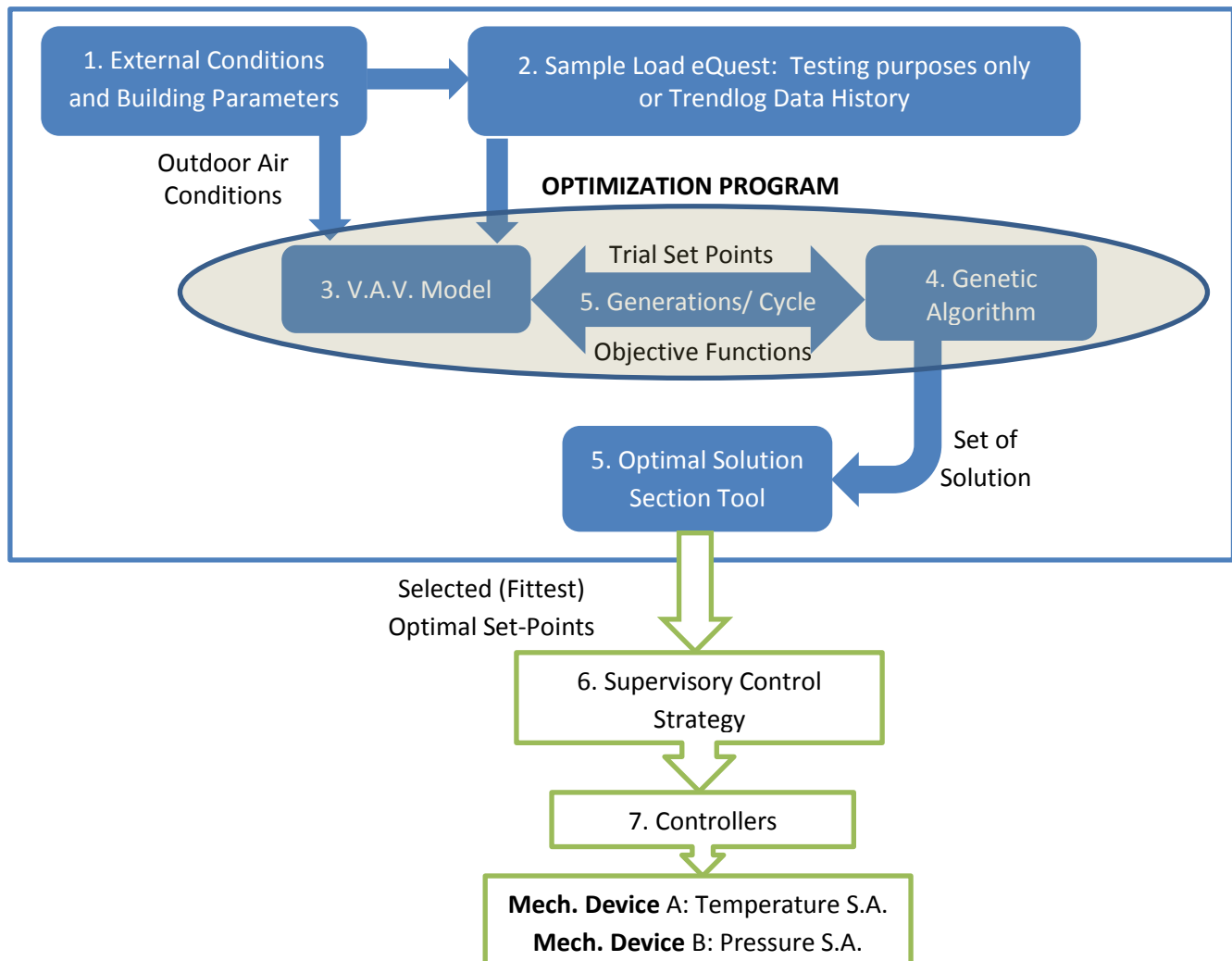

Figure 1. Optimization Process.

1.5 Research Objectives

Building automation systems in HVAC offers a great solution to energy conservation. Through the control systems, this paper evaluates the algorithms used for reset controllers and optimizing the energy consumption while still meeting with environmental standards. The main objectives during this research are to develop an optimization tool for use in the MATLAB OptimTool which is integrated in the Building Automation System for the air side distribution of HVAC. Furthermore, a study on the energy consumption were also applied to the ASHRAE Standard 62.1 codes from 1989-2003 and 2004-2013 when the formula was modified specifically to account for area and occupancy. This proposed strategy considers the ventilation requirements by the recent version of ASHRAE Standard 62.1- 2013.

1.6 Limitations

Although the algorithm develops setpoints, there are limitations to which real processes can occur without adverse impacts. The limitations exist as upper and lower boundaries in the variables and the constraints defines the possible solutions. Two main boundary conditions for the GA apply to supply air temperature and supply air pressure. The supply air temperature is bounded between 55°F and 65°F whereas supply air pressure is bounded between 1.0 and 3.0 inWg. While lowering the supply air temperature can be advantageous, it can also cause icing in the buildup causes blockages of airflow and insulating effects of the frost layer itself (Reindl & Jekel, 2009). Extreme supply air temperature may cause issues such as icing or lost dehumidification capability whereas supply air pressure extremities can cause air starvation or surging issues.

1.7 General Description--Air Side Distributions

The VAV must be understood mechanically and through its control systems before developing an optimization strategy. Figure 2 shows a general air handling unit depicting return air, mixed air, and supply air statuses. Also shown are three dampers including exhaust, outside air, and return air. The air flow circulates from return air where it can be exhausted or back to mixed air with outside air (OA), before the air handling unit (AHU), and then back into zones as supply air (SA). The chilled water (CHW) valve modulates and controls the temperature of the supply air whereas the supply fan controls the supply air pressure. Here, controller C1 controls the valve position of the chiller water passing through the inside the air handling unit's cooling coils and thus the supply air temperature. Controller C2 controls the supply air pressure through the fan where typically a variable speed drive is used. Controller C3 modulates the air flow through the zone. Binary outputs result in on or off positions of actuators whereas analog outputs result in partial positions.

This study emphasizes on the air distribution side starting mechanically from the air handling unit where the mixed air passes through the cooling coils to the fan and becomes supply air for the terminal zones. Initially, mixed air (MA) starts before air handling unit (AHU) and passes through the cooling coils where the supply air temperature (SAT) is first regulated. In conventional units, all air is held constant at 55°F for the cooling months. The cooling coil valve, CCV, determines the temperature at which the supply air temperature. Several options in SAT regulation and controls include constant and SAT reset. Constant SAT regulation can be later modified by terminal reheat or dampers whereas SAT reset are constantly monitoring demand and adjusting the CCV as appropriate.

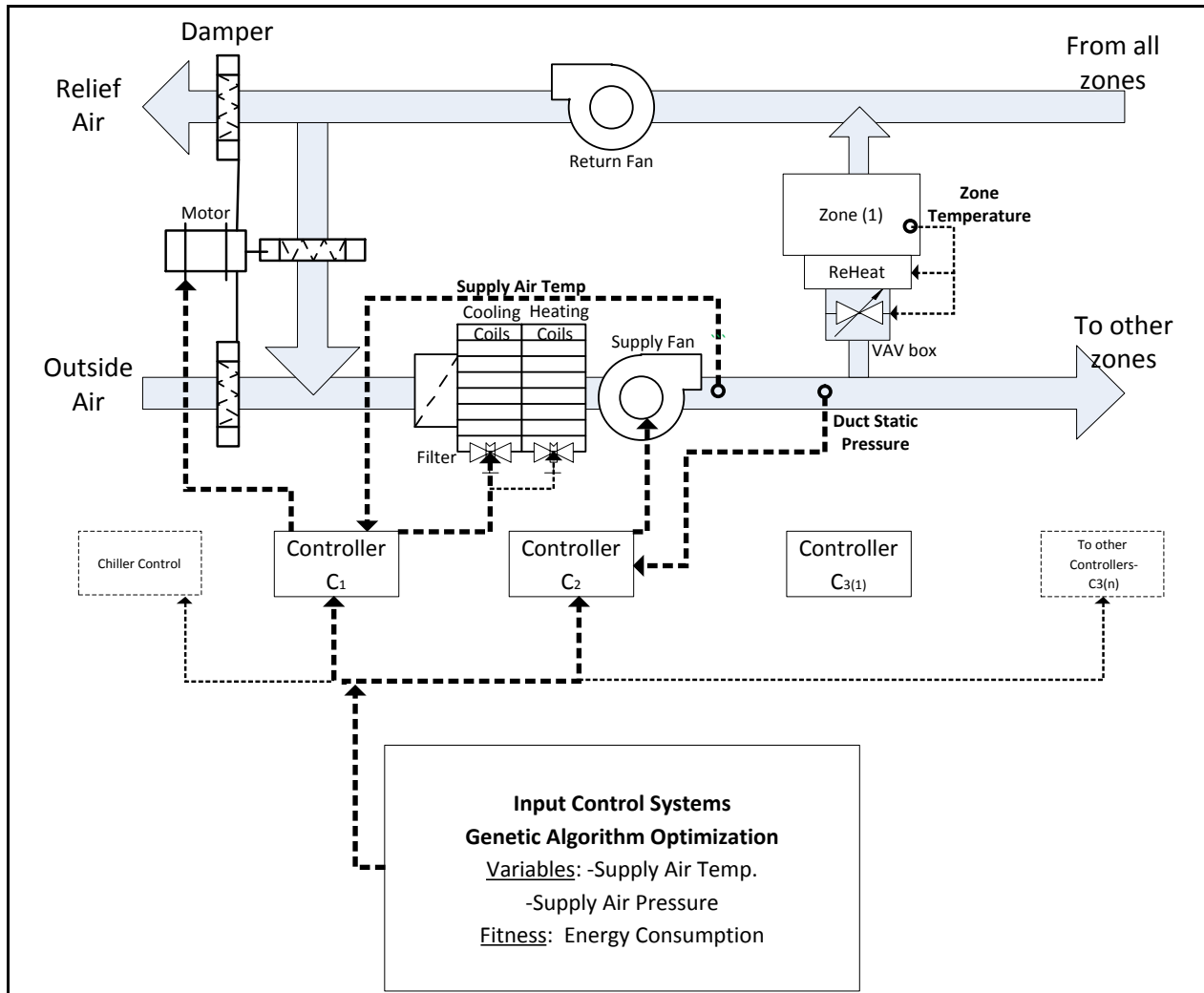

Figure 2. General Schematic of Supply Air Control System.

1.8 General Description--Variable Air Volume

The VAV regulates the final temperature of the supply air at the terminal distribution. There are various ways to classify VAV systems. While there are many terminal air distribution systems today, there are two main types: constant air volume and VAV. In constant air volume, CAVs, the volume of air is constant until it cools the critical determining zone or room. The fan is either on or off determined by the critical zone. CAVs offer a lower initial cost but higher operating cost due to lack of specific control. In CAVs, the AHU is only on or off and

determined by the critical room which is the room needing the most cooling or heating. In VAV, VAVs, the control in the temperature by amount of air flowing to a zone is controlled by a modulating damper (ASHRAE Applications, 2011). Depending on the set-point of the thermostat has been met or partially met, the damper will partially or fully close in a conventional control. Furthermore, two general control designs by VAVs include pressure dependent and pressure independent. In pressure dependent, the damper position is controlled with regards to room temperature only- there is without regards to flow rate or reset control to other zones. Whereas in pressure independent, the control accounts also to flow rate, resets, and better individual control of room temperatures. Pressure independent are valuable in that if one zone is satisfied and closed and thereby increasing the pressure in another terminal zone, the feedback is important because dependents VAVs only recognize damper position. Supply air temperature reset modulates the chilled water and aims to reduce compressor hours where energy is saved. Supply air temperature can also be reset to higher setpoints at the cost of preventing cooling of the highest demand within zones. However, at the other spectrum, supply air temperature resets that are too low carry the advantage of dehumidification but higher energy in reheat. Compared to constant air volumes, VAVs use 60% of the airflow and thus save energy in fan speed reduction and static pressure (Dieckmann, 2012). VAVs can also be organized by fan placement in series or parallel with each offering different strategies. Series VAV's passively induce plenum return air while parallel fan is placed in line with the plenum air. Series designed fan are also designed to run continuously in cooling mode whereas parallel fans are designed to be run in low-cooling needs and also heating modes. Since parallel fans are run intermittently and have a greater control of utilizing plenum air, the energy savings are greater. VAV was also selected during this study which takes advantage of typical VAV savings at the air handler and

chiller during the cooling periods but the real savings occurs when it induces warm plenum air from the ceiling and blends it with the primary at minimum ventilation requirements during the heating sequence. This recaptures the heat instead of wasting it back at the air handler.

CHAPTER 2

Literature Review

2.1 Introduction

Supply air side setpoints were the main topic in this study. Numerous studies show that VAVs continually prove to be amongst the leader when utilized in real world application. In an application and competition study with the UC Davis Medical Center Graduate Studies Building, variable air volume reheat, VAVR, proved to be a tough competitor and winner against Active Chilled Beams plus Dedicated Outdoor Air Systems, ACB+DOAS. VAVR had much lower first cost, energy costs, and achieving similar floor to floor thermal air quality (Stein & Taylor, 2013, p. 30). VAVs can even be further advanced with smarter controls offering energy strategies such as ‘Dual Maximum’ VAV box control logic as suggested by Taylor, Stein, and Paliaga. In dual maximum logic, the maximum airflow is reset to be higher than 30% of the ASHRAE Standard 90.1-2010 and California Title 24-2010 which limit the usage of reheat at a constant to 30%. Instead of the maximum heating airflow being the same as the minimum airflow rate that is allowed in single maximum strategy, the dual strategy allows the hot water valve opening and higher airflow change with respect to safety limitations (Taylor, Stein, & Paliaga, 2013).

This section gives a summary of the major ideas regarding the study of GA and its relevance to heating, ventilation, and air- conditioning (HVAC). This analysis show that most studies can be categorize in several ways including theoretical analysis, case-study results, and simulations models. Although there are many simulation studies revolving VAV, the primary focus is utilization of artificial intelligence. Much research has determined while VAVs have higher initial cost and investment, the energy savings are greater compared to CAVs or Fan Coil Systems (FCS). Further simulated technologies such as utilizing variable speed compressors

with pressure independent VAV has a bigger impact on energy conservation (Chen & Deng 2006).

The literature review will cover topics on building and energy simulations, theoretical analysis of control designs, and applications of GA. As a background source of information, literature from several renowned building technical societies were included in above areas including the *ASHRAE Handbook*; *ASHRAE Journal*; *ASHRAE HVAC&R Research*; and prior lectures from NC A&T State University.

2.2 Optimization of HVAC Control Systems Strategy using G.A.

In this case study, it was shown that using GA for as part of the supervisory control reduced energy consumption by 16% for two summer months (Nassif, 2005). This study highlights that using global system better optimizes its full potential in energy savings in contrast with local level control. The research was implemented at Ecole De Technologie Superieure campus in Canada with air handling unit, AHU 6, and 70 zones being studied. Local level control often maintains constant temperature in supply air temperature and supply air pressure whereas continuously resetting these values at interval times gave a better feedback and response to demand and resulted in energy savings. Two objectives were created during the study- energy and thermal comfort. Thermal comfort, ASHRAE 55D can be quantified and measured as a proportion of predicted percentage of dissatisfied (PPD) and predicted mean vote (PMV) according to 2011 ASHRAE Handbook. Thermal comfort is scaled by the PMV and based on six factors to include: metabolic rate, clothing insulation, temperature, radiant temperature, air speed, and humidity. Using the energy models and algorithms for the HVAC and PPD equation for thermal comfort, an optimized setpoints was created for the reset variables. Thermal comfort

as a second objective is important because as energy consumption is reduced, extreme boundaries of HVAC setpoints may cause an unbearable air quality for occupants. The optimization process was based on a Non-Dominating Sorting Genetic Algorithm, NSGA II, in which a pareto curve convergence was created to obtain the optimal setpoints. NSGA II offers many advantages for multi-objectives because they are able to utilize a tradeoff trend in which either a weighted performance sum or pareto curve is used. The main difference from single-objective optimization is that a multi-objective problem does not have one single optimal solution, but instead has a set of optimal solutions, where each represents a trade-off between objectives.

Furthermore during the design algorithm, the computation for outside air ventilation, ASHRAE 62.1 was based upon 1989 guidelines. In the 1989 version of ASHRAE 62.1, the outside air had an Estimated Maximum Occupancy of (People/1000 ft²) and was reflected in the airflow rate. The airflow rate per person was higher but at the cost of not equating area into the formula. The analysis of ASHRAE 62.1-2013 has been updated to reflect air flow rate not only in terms of people but also space area.

2.3 Optimized Supply-Air Temperature (SAT) in Variable Air Volume Systems

Supply air temperature reset controllers (SATRC) offer many opportunities for energy conservation. In Ke and Mumma simulation of supply air reset, three criteria for developing SAT setpoint were determined with the objective of determining and lowering energy cost. The three researched criteria included outside air temperature, zonal thermal loads, and humidity limitations were compared at different times throughout the year in Harrisburg, PA. Furthermore, the relation of OA temperature can fall in categories of being higher than return air (RA), between supply (SA) and return, and lower than supply air temperature. As the

temperature of the OA decreases to SA, the load is generally shifted from the cooling coil to the OA. However, when the OA temperature goes below the SA temperature, free cooling occurs where no energy is consumed to lower SA temperature- plenum air is used to rewarm the air.

Although the SATRC can save energy during moderate seasons such as spring and fall; it also can adversely increase fan energy consumption where the fan energy may overrule this benefit. As the SATRC approach higher temperatures, the disadvantage were the supply air fan running at higher speeds and lost capability of dehumidification. SATRC was most optimal and could save energy if the system was able not turn on the VAV reheat on also or tempering, still meet minimum ASHRAE 62.1-1989 and necessary dehumidification. The conclusion of the study recognized 16% reduction ratio of OA for March and 18% for November (Ke & Mumba 1997). Likewise, the power demand was lowest during expected seasons that OA economizer would be most beneficial and included March, April, October, and November. The simulation also found that SATRC was marginally optimal in peak summer when compared to fixed SAT but not during the peak winter because the SATRC is advantageous to cooling and not heating energy. Overall it was concluded that SATRC was better than fixed-SAT and saved 6.2% in annual cost (Ke & Mumma, 1997).

2.4 A Model-Based Optimal Ventilation Control Strategy of Multi-Zone VAV Air-Conditioning Systems

Another model reflecting the advantages of using GA was simulated in a study of multi-zone VAV air-conditioning systems. Since several prior studies were conducted in single path air supply and CO₂ as the primary indicator of occupancy, the researchers wanted to study the effects of demand control ventilation (DCV) in multi-zone and also take a more comprehensive

approach. The objectives were aimed at reducing energy consumption while still meeting standards for thermal comfort and indoor air quality. Figure 3 shows how the equations were implemented in the control strategy for a multi-zone operation.

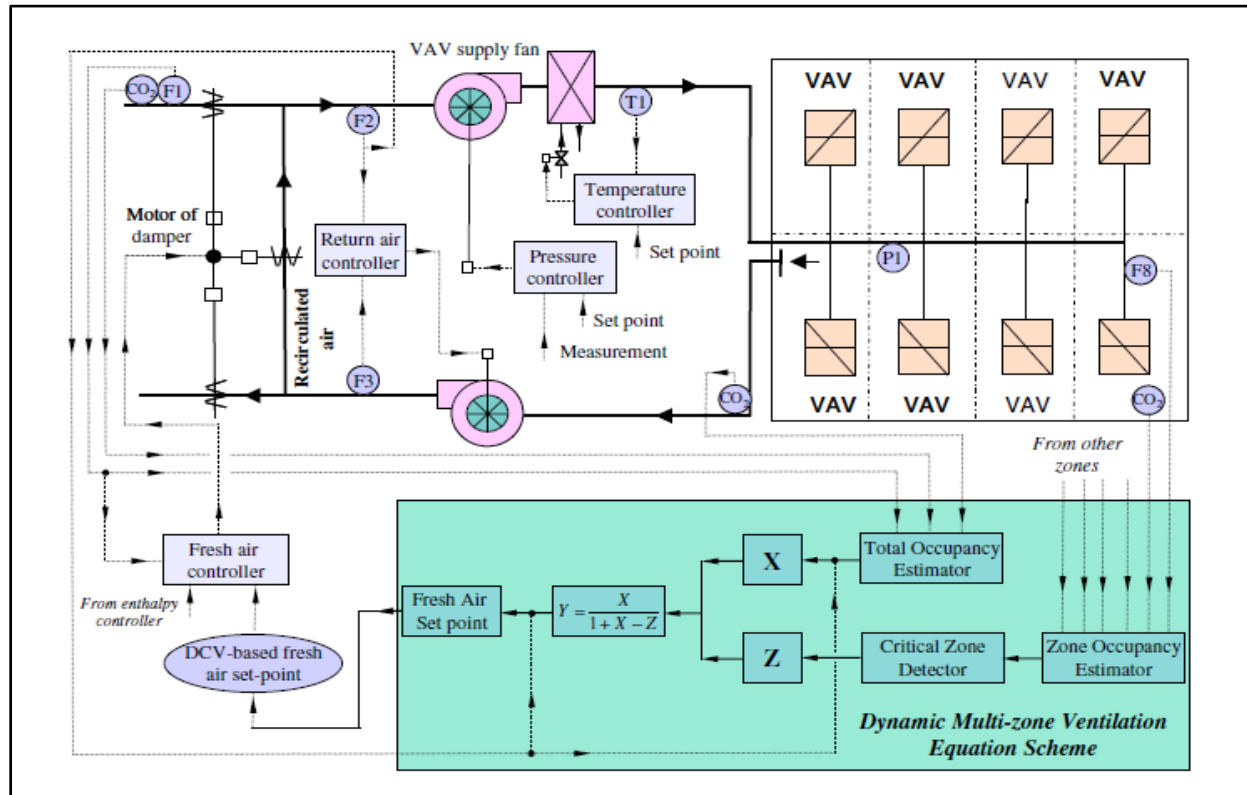

Figure 3. Diagram of the Dynamic Multi-Zone Ventilation Equation Scheme. (Xu, Wang, Sun, & Xiao, 2009).

Overall, two schemes were used for the ventilation- one using the ventilation equation scheme where fresh air correction was used and the second strategy involved utilizing the dynamic temperature set point reset to the critical zones. The ventilation equation was adjusted due to the fresh air that still existed from the over-ventilated zones and ASHRAE 62.1- 2001 and 2004 which was based on people and area: $V_{bz} = (R_p \cdot P_z) + (R_a \cdot A_z)$ and was considered the conventional DCV strategy and categorized based on five differing weights. In the second strategy, the dynamic temperature reset was compromise between factors such as energy

consumption, thermal comfort, and indoor air quality. Thermal comfort was measured as an index of predicted mean vote (PMV) and predicted percent dissatisfied (PPD) according to the thermal sensation scale of ASHRAE 55. In addition, whereas the conventional strategy used an equation scheme to determine solutions, the computation process or optimizer to solve the second scheme was GA.

The results of conventional versus multi-zone DCV strategy offered many possible solutions when balancing thermal comfort, indoor air quality, and energy consumption. For all the testing during the sunny summer day, the multi-zone DCV strategy was considered the baseline. For the conventional DCV strategy, the average thermal comfort, 6.92 PPD%, which indicated better score compared against any of the other multi-zone DCV strategy. It also saved significantly higher energy in the cooling energy consumption, 17.36%, and overall power consumption, 11.92%. However the tradeoff was that for the conventional DCV, the average CO₂ ppm was relatively higher compared- 834 for convention versus 700 for multi-zone DCV. Although all the additional five weight settings for the multi-zone DCV did not show as significant high of a cooling energy and power consumption, the advantage was that it reflected better indoor air quality in which CO₂ level was the primary agent being tested for. The five weight settings of multi-zone thermal comfort was also marginally worse ranging from 0.94-1.30 higher PPD than conventional DCV. In all the DCV modeling, the fan energy only marginally varied from 0.20% to 1.37% worse than the multi-zone DCV. The research highlights that the ventilation strategy is able to optimize performance according to different set weights. Weighting factors are done with coefficients and depending on situation and building; some factors may have larger importance and must compromise between cost, environment, or priority.

2.5 Summary

During this investigation, we studied the air distribution to zones. While there is much research also to the chiller, water loop, and condensing section of HVAC, the primary focus is the consumption of energy at the air distribution as it passes through the evaporator and coiling coils to the room. Many published articles have shown the effectiveness of using reset controllers and using various strategies such as VAV trim and response methods at the individual level but not system integration particularly with artificial intelligence methods (Taylor, 2007). While this study does not differentiate in depth between constant and variable systems, a further analysis can be conducted for optimization. It is found VAV systems often provides better performance, initial cost, and life-cycle cost due to lower fan- operating costs (Aktacir & Yilmaz, 2006). VAV systems have been offering great solutions to recognizing occupied and unoccupied zones.

Much research and modernization has also been conducted to ASHRAE 62.1 ventilation standards. One of the foremost improvements to Standard 62.1 was the modification to include zone population with floor area from 2003 to 2004. Recycling air and minimizing the OA in air distribution offers many opportunities for energy conservation. Maintaining high indoor air quality (IAQ) is one of the main objectives due to particles, gases, and vapors that can threaten health and productivity (Mcdowall, 2007). IAQ is accomplished through ASHRAE standard 62.1 and can be taken further in an ASHRAE Journal which Stanke also critiqued the 11 sequential design step calculation for OA ventilation. Throughout the calculation of minimum airflow rates, the strategy focused on using actual population instead of estimates and actual airflow values at 80% to show that ventilation airflow can be reduced at non-design conditions (Stanke, 2010). Although more accurate and actual people counting can reduce energy consumption, the cost may be far outweighed and not readily available. Actual population

counting can be advantageous because it can limit the amount of OA through its design' Multizone System (MZS) calculations of ventilation with building automation systems, whereas CO₂ sensory technology has no MZS calculations but rather just opens and close damper according to design level (Stanke, 2010). Besides CO₂ based reset for ventilation, other technologies include using Airflow-based VRC, occupancy sensing, and using VRC with timing schedules based on estimates. Overall design and operations of utilizing ASHRAE 62.1 ventilation standards may conflict since design intake airflow always equal or exceeds the intake airflow needed at non-design conditions. Changing the OA ventilation code strategy may offer one potential whereas other strategies include controlling the economizers. Nassif's split-control of the OA, RA, and DA and Yao's enthalpy-based economizer's are several concepts to further the energy-saving performance (Nassif, 2010; Yao, 2010).

Outside air is just one example where it can be set to be more dynamic in the simulation and GA could be developed in conjunction with supply air temperature and pressure. The 2013 edition of Standard 62.2 incorporates 20 addenda to the 2007 version itself and thus is a continually evolving (Emmerick, 2011). Outside air and humidity becomes an important issue in regards in North Carolina's climate index of 4A by. Dehumidification consumes very high energy as it has to be sub-cooled to a lower setpoint for condensation to occur and also paralleled with reheat energy cost. Charles Cromer also in 2001 innovated a process for dehumidification by using the excess subcooled temperatures for water removal condensation to preheat the return air via a precooled coil that otherwise be reheated at the VAV (Dieckmann, 2012). However, higher OA airflow may not always consume more energy especially when combined with total energy recovery equipment and economizers as investigated a study by Dr. Mumma when 30% surplus OA was used. Several design systems in becoming more energy efficient includes

dedicated outdoor air systems (DOAS); decoupled ventilation/recirculation systems; personalized ventilation (PV) system; displacement ventilation (DV) system; and under floor air-distribution (UFAD) system (Sekhar, 2013). Other technologies include the usage of energy recovery ventilation (ERV) which has been mandated in ASHRAE 90.1-2010 and has been shown to have up to 70% energy savings (Hastbacka, Dieckmann, & Bouzza, 2013).

CHAPTER 3

Methodology: Building Load Development

3.1 Introduction

The building load analysis was conducted through eQuest for testing purposes only. The goal was to extract the load calculation or in other applications, a trend log or history of data setpoints could be used. The initial steps were to first simulate the building through eQuest. eQuest is an energy consumption and building load performance predictor after selecting the building type and mechanical system. The heat load data is then extracted and organized in Excel. From the heat load data, GA tool is performed in a sequence of steps to obtain the total energy. GA is utilized through MATLAB through the Global Optimization Toolbox which determines the best fit supply air temperature and pressure with the least energy consumption.

3.2 eQuest Building Simulation

During the algorithm development, the outside air conditions, building characteristics and internal load determined the energy consumption. eQuest is a building energy software that can simulate building energy performance and analysis with Department of Energy's guidelines, DOE-2, using ASHRAE 90.1 as the baseline. Simply summarized from the eQuest website, DOE-2, in its raw standard form is a batch-oriented program, for which you create input files with your building description in DOE-2's building description language or BDL to simulate energy performance from architectural, lighting, and mechanical domains (eQuest 4). Within eQuest, many standards including ASHRAE and LEED standards and codes can be configured to simulate building performance. From the eQuest simulation, 20 zones' sensible and total loads were created. Outside air conditions is based on peak cooling day of the entire year. Design minimum supply air flow, space areas, and number of people per zone are computed by eQuest.

Flow coefficient, fan efficiency was determined by industry nominal range of values. ASHRAE 62- 2013 Standards for Minimum Outside Air Intake per zone is based on number of people and square footage per zone. In Figure 4 are the major characteristics are the overall area is 30,300 ft²; Utilization Type- Office Building; Simplified time scheduling of mechanical setpoints; Location: Greensboro, NC; and Code Analysis: LEED- New Construction; ASHRAE 90.1.

The screenshot displays the 'eQUEST Schematic Design Wizard' window, specifically the 'General Information' tab. The interface is organized into several sections:

- Project Information:** Project Name: Research Project; Building Type: Office Bldg, Two Story; Code Analysis: LEED-NC (Appendix G); Code Vintage: version 3.0.
- Location Information:** Location Set: All eQUEST Locations; State: North Carolina; City: Greensboro; Jurisdiction: ASHRAE 90.1; Region/Zone: 4A - Mixed, Humid.
- Utility and Rate Information:** Utility: Electric: - file -, Gas: - file -; Rate: Electric: - none -, Gas: - none -.
- Area and Floors:** Building Area: 30,300 ft²; Number of Floors: Above Grade: 2, Below Grade: 0.
- Cooling and Heating:** Cooling Equip: Chilled Water Coils; Heating Equip: Hot Water Coils.
- Other Data:** Analysis Year: 2012; Daylighting Controls: No; Usage Details: Simplified Schedules.

At the bottom of the window, there is a 'Wizard Screen' indicator showing '1 of 41', along with navigation buttons for 'Help', 'Previous Screen', 'Next Screen', and 'Finish'.

Figure 4. Developing a Baseline for Building Design Load in eQuest.

The building is divided into areas with respect to sun, size, type of rooms, and location, core or perimeter, where it is to be controlled by one thermostat per zone. The first floor layout is the same as second floor and is also composed of 76.5% perimeter spaces. Two floors with generalized zones, Figure 4, are created. There are 20 zones with the first number indicating

ground floor, and the second number indicates top floor in Figure 5.

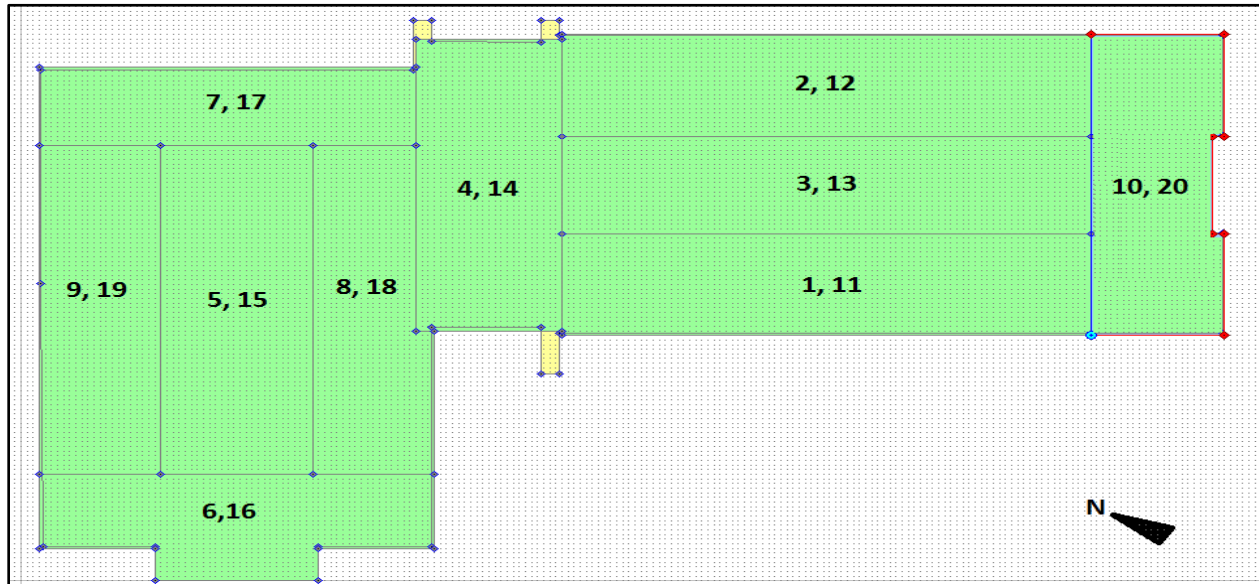

Figure 5. Interior Space Zoning of Buildings Layout.

Every zone is specifically different by many factors including number of people, building orientation to sun, number of windows, and thus leads to a different amount of load factors and temperature control. Sensible heat is related by a change in temperature but not changes phases whereas latent is related to phase change but not change in temperature. Latent heat is best described as the water effect or humidity whereas electric heat and convection is an example of sensible heat. The total heat load is directly related to sensible heat and any changes are proportional. eQuest processed these zones automatically in the example but can be manually adjusted to specified characteristics such as perimeter or core, number of occupants, type of rooms such as computer or lecture rooms

The screenshot shows the 'Cooling Primary Equipment' configuration window in the eQUEST Schematic Design Wizard. The window is titled 'Cooling Primary Equipment' and contains the following settings:

- Chilled Water System:**
 - CHW Loop: Head: 41.6 ft, Design DT: 10.0 °F
 - Pump Configuration: Single System Pump(s) Only
 - Number of System Pumps: 1
 - CHW Loop Flow: Constant
 - Loop Pump: Head: [] ft, Flow: [] gpm
 - Motor Efficiency: High
- Estimated CHW Load:** 30,319 ft² Served x Size Factor: 1.20 / 480 ft²/ton = 75.8 tons.
- Total Chiller Capacity by Type:** Type 1: (auto-sized) Type 2: (none) = (auto-sized)
- Describe Up To 2 Chillers:**
 - Chiller 1:**
 - Chiller Type(s): Electric Reciprocating Hermetic
 - Condenser Type(s): Packaged Air-Cooled
 - Chiller Counts & Sizes: 1, Auto-size, <150 tons
 - Chiller Efficiency: 1.302 kW/ton
 - Chiller 2:** - select another -

The bottom of the window shows 'Wizard Screen 31 of 41' and navigation buttons: Help, Previous Screen, Next Screen, and Finish.

Figure 6. HVAC Mechanical Equipment Selection.

In Figure 6, the equipment is auto sized using a single system pump with one hermetic chiller per floor for a total of two chillers. It was estimated to be at 75.8 tons based upon the design load. Other characteristics include: Primary System Chiller Design Pump, 95 ton Chiller, and a Packaged Air-Cooled Condenser or direct air, heat exchange removal systems.

In Figure 7, a VAV is selected for the terminal air distribution. Although the system baseboard heaters are shown for summer heating, the primary focus of this study focuses on cooling. Among the air side, the air handling unit is also depicted through the chilled water coil and supply fan. The air handling units will distribute the air to the VAV's within the zone. After modeling the building performance by EQuest, a building load output was created in Figure 8. The sensible heat load and total heat load is determined for each zone by day and hour.

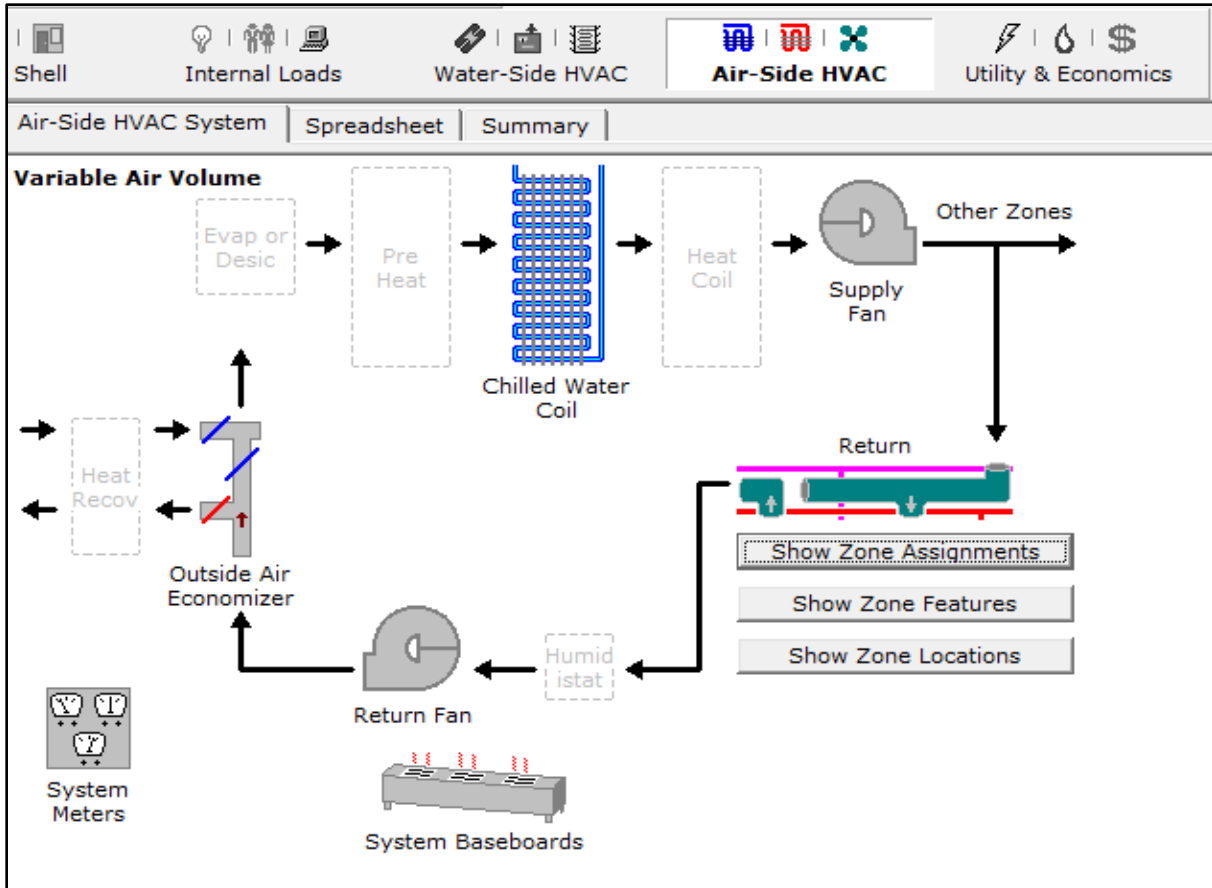

Figure 7. eQuest Overall Air-Side System Selection.

3.3 Load Extraction

A summation of the loads as shown in Figure 8 can be determined in various categories such as time and zones to be used as data for MATLAB and GA optimization. Furthermore, it can be compared against the GA optimization for energy analysis.

C:\Users\TonyNuge\Desktop\RESEARCH\EQQuest 1\Research Project - Baseline Design
 Simulated: 2012-May-18 09:59:38
 CSV Written: 2012-May-18 09:59:38
 eQUEST 3.64.7130

JUNE 28- Peak Cooling

Hourly Report

				EM1 Hourly Report B		Hourly Report Block		Hourly Report Block		Hourly Report Block		Hourly Report Block		Hourly Report Block		Hourly Report Block	
				SPACE		SPACE		SPACE		SPACE		SPACE		SPACE		SPACE	
				SE Space (fg.s1)		NE Space (fg.s10)		Cor Space (fg.s3)		NW Space (fg.s2)		WNW Space (fg.s4)		Cor Space (fg.s5)		SE Space (fg.s6)	
				Var 42	Var 44	Var 42	Var 44	Var 42	Var 44	Var 42	Var 44	Var 42	Var 44	Var 42	Var 44	Var 42	Var 44
Month	Day	Hour	Type	Space sen	Space tot	Space sen	Space tot	Space sen	Space tot	Space sen	Space tot	Space sen	Space tot	Space sen	Space tot	Space sen	Space tot
1	1	1	7	-2129.47	-2129.47	-4211.47	-4211.47	11.7935	11.7935	-3271.8	-3271.8	-544.607	-544.607	11.4586	11.4586	-4455.23	-4455.23
1	1	2	7	-2372.86	-2372.86	-4497.88	-4497.88	11.8891	11.8891	-3466.63	-3466.63	-605.95	-605.95	11.5515	11.5515	-4727.79	-4727.79
1	1	3	7	-2550.92	-2550.92	-4701.8	-4701.8	11.8881	11.8881	-3600.26	-3600.26	-647.847	-647.847	11.5505	11.5505	-4920.94	-4920.94
1	1	4	7	-2701.39	-2701.39	-4871.13	-4871.13	11.8871	11.8871	-3709.82	-3709.82	-682.256	-682.256	11.5495	11.5495	-5080.49	-5080.49
1	1	5	7	-2784.98	-2784.98	-4958.49	-4958.49	11.8862	11.8862	-3755.06	-3755.06	-696.01	-696.01	11.5486	11.5486	-5161.37	-5161.37
1	1	6	7	-3069.83	-3069.83	-5295.73	-5295.73	10.0031	10.0031	-3981.57	-3981.57	-770.354	-770.354	9.71918	9.71918	-5490.37	-5490.37
1	1	7	7	-3161.51	-3161.51	-5393.12	-5393.12	10.0023	10.0023	-4034.42	-4034.42	-786.747	-786.747	9.71834	9.71834	-5581.87	-5581.87
1	1	8	7	-2658.22	-2658.22	-4320.4	-4320.4	13.7657	13.7657	-3334.07	-3334.07	-594.793	-594.793	13.3747	13.3747	-4859.54	-4859.54
1	1	9	7	-1336.54	-1336.54	819.44	819.44	19.4113	19.4113	-1384.78	-1384.78	-110.465	-110.465	18.8596	18.8596	-2373.93	-2373.93
1	1	10	7	191.217	191.217	4773.95	4773.95	23.1748	23.1748	-35.3555	-35.3555	271.345	271.345	22.516	22.516	9.54269	9.54269
1	1	11	7	3163.36	3163.36	9636.46	9636.46	28.8205	28.8205	1408.77	1408.77	686.007	686.007	28.001	28.001	3398.72	3398.72
1	1	12	7	6023.7	6023.7	9907.27	9907.27	36.3484	36.3484	2927.72	2927.72	1118.41	1118.41	35.3146	35.3146	5587.84	5587.84
1	1	13	7	14883.6	14883.6	16220.2	16220.2	41.9942	41.9942	4130.3	4130.3	1467.41	1467.41	40.7997	40.7997	13002.8	13002.8
1	1	14	7	11306.4	11306.4	9989.64	9989.64	40.1114	40.1114	3748.21	3748.21	1372.39	1372.39	38.9706	38.9706	9004.82	9004.82
1	1	15	7	14377.9	14377.9	9012.16	9012.16	40.1109	40.1109	3450.52	3450.52	1316.33	1316.33	38.97	38.97	10675	10675

Figure 8. eQuest Baseline Design Data, complete listing in Appendix A.

eQuest has many unique properties when it comes to simulating a building performance.

In Table 1, the design data was extracted through an analysis of each zone’s property. Among the design data extracted was the airflow rate, space area, and number of occupants.

Table 1

Building Design Data Extracted from eQuest

	Zone #:									
	1	2	3	4	5	6	7	8	9	10
AirFlow Rate	3370	2961	1082	1600	1051	2532	1028	1546	2035	2513
Space Area	1914	1914	1827	1517	1775	1225	1048	1300	1420	1388
People #:	24	24	13	19	13	16	13	17	18	18
	Zone #:									
	11	12	13	14	15	16	17	18	19	20
AirFlow Rate	2945	2606	1082	1300	1051	2127	814	1330	1729	2202
Space Area	1914	1914	1827	1517	1775	1225	1048	1300	1420	1388
People #:	25	25	17	20	16	16	14	17	19	18

CHAPTER 4

Optimization Model

4.1 Introduction

In this chapter, there are two main parts to the optimization, GA and development of the air distribution algorithms that will simulate the energy consumption. The GA tool is already developed by MATLAB but a discussion of how the optimization process will be discussed. In addition, the air distribution algorithm was created through the fundamental theories and equations from hydraulics, fluids, and thermodynamics with the end product being energy consumption at each stage of sequence. The GAHVACModel and VAVModel were the algorithms used to create these files for the air distribution with the GAHVACModel being like the cover or main page with all the major variables being listed on it. The VAVModel would run each sequential step through the air distribution but also include energy consumption from the air distribution to the chiller. The coiling coil and chiller algorithms were provided by the ASHRAE Toolkit 2.

4.2 Genetic Algorithm Description

Through artificial intelligence utilization, the energy consumption can be better managed. Building controls are like living organisms which can be treated much like evolutionary biology, in the programming respectively. Treating control systems inputs like chromosomal DNA, the algorithm processes the binary codes through crossing, mutation, and tournament selection with setpoint outputs to optimize the mechanical system. The random set of parents is hybridized to produce an offspring which also defined as one generation. During the hybridization, through processes of crossing over and mutation, to preserve diversity, a child is produced in the generation. As each generation proceeds, the fittest code or trait survives into the next until an

optimum fitness is determined. GA in depth has many advantages and uses in solving complex problems. Traditional methods of solving problems sometime can lack efficiency when calculating every function value in the search space and moving only in the direction related to the local gradient instead of searching the population. GAs differ from other search and optimization algorithms because they work with a coding of the parameter set, not the parameters themselves, searches from a population of points- not a single point, use payoff information instead of derivatives or other auxiliary knowledge; and use probabilistic transition rules, not deterministic rules (Goldberg, 1989). While GA is used in this study, other types of artificial intelligence have been simulated to show energy conservation also. Fuzzy logic controllers used in conjunction with DCV strategies and various economizer cycles has effectively conserved between 44% and 63% per day energy savings (Karunakaran, 2010).

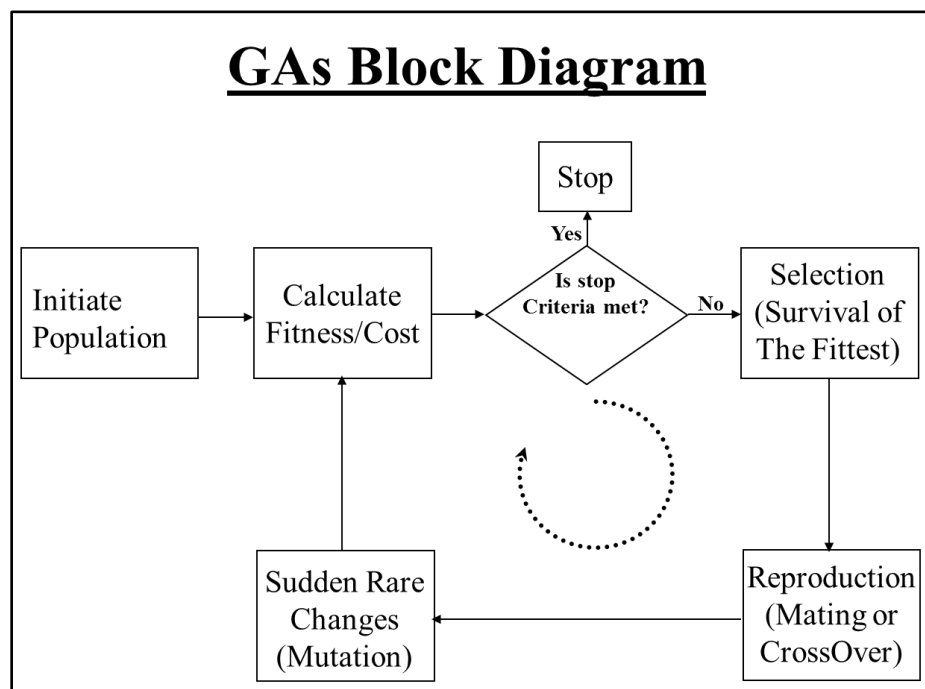

Figure 9. General Genetic Algorithm Model.

The algorithm begins by creating a random initial population as shown in Figure 9. The algorithm then creates a sequence of new populations. At each step, the algorithm uses the individuals in the current generation to create the next population. To create the new population, the algorithm performs the following respective steps: evaluates the new population by calculating its fitness and grades the fitness, goes through the first main operator call selection in which the parents are chosen based on fitness, then hybridization of the parents in which a new offspring is produced after mutation and crossover combinations. A generation cycle is complete after the offspring succeeds and becomes the new parents (Mathworks). During the process of GA, several computing terms are representative of the biological reproduction system. The population size is the array of individuals, row vectors, translated into a matrix. Diversity is maintained by the mutation and crossover operators so that the entire space is searched. The chromosome length is the length of the row vector determined in bits. Finally the fitness vector contains the fitness values corresponding to the individuals in the population.

4.3 MATLAB- Optimtool for Genetic Algorithm

MATLAB is an advanced numerical computing and simulating software. Within the software, there is a Global Optimization Toolbox which has built in GA programs that is able to produce a set of optimal setpoints for the VAV air distribution system. During this research, the it was conducted at steady state. The GA program and VAV model different in that GA produces a random hybridized optimal setpoints for test in the VAV model which is a series of sequential operating system that calculates energy usage. For each cycle or generations of GA, the child setpoints which are produced are evaluated through the VAV program. The objective goal during this study is to introduce how energy can be minimized with GA using the following objective variables- supply air temperature and supply air pressure with energy consumption

defining the fitness. From the setpoints, SAT and SAP, energy consumption is calculated for the terminal reheats, fan power, and chiller power respectively. The following settings are used for the GA: Population size = 100; Reproduction and Crossover fraction = 0.8; Mutation function = Constraint dependent default; Generations = 100.

4.4 Variable Air Volume Model

The GA computes setpoints for energy analysis through the variable air volume model. In overview, the input variables from eQuest including the loads, outside air conditions, and design criteria are input into the algorithm. The algorithm then respectively determines the actual zone airflow rates, amount of reheat, outdoor air flow, and basic calculations involving the air's latent heat. Depending on the cooling load at the zone, the cooling coil model and chiller model calculates its respective energy consumption. Figure 10 shows the major component of the optimization model and its interface with the input values, output values, and GA.

Input Optimized Variables: The variables are supply air temperature, T_s , and duct static pressure, P_s .

Outside Air Condition: The eQuest extracted data included the loads, outside air condition, and design airflow. The loads were the sample data extracted from eQuest gives our sensible and total heat load for the entire year. From this, the peak day for cooling was July 15th. The peak outside air condition was selected upon a random high condition. Typically design conditions can be found within the ASHRAE Fundamental 2009- Ch. 14 at different corresponding annual, cumulative frequency of occurrence. The design occurrence frequency

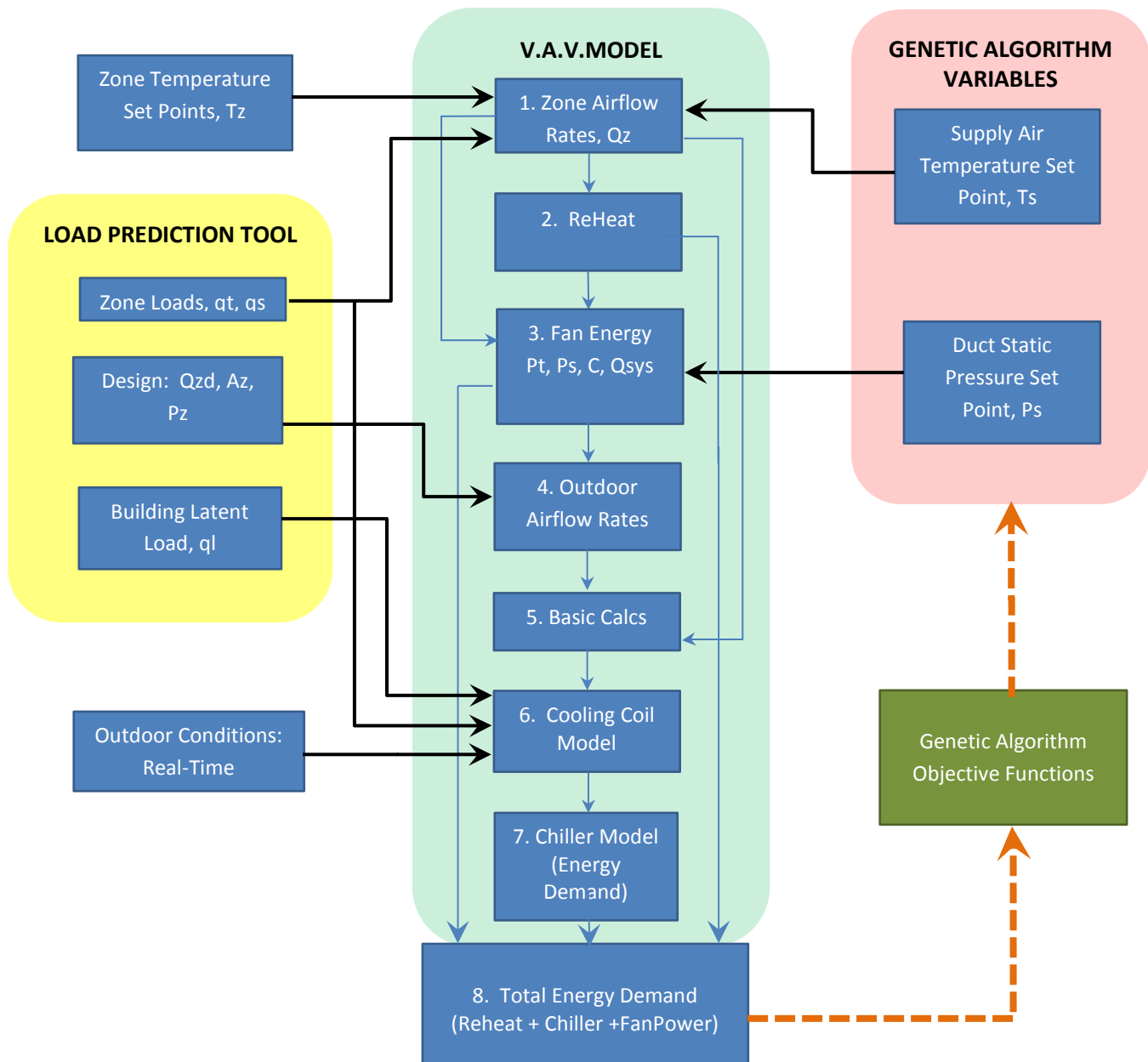

Figure 10. Optimization Model Organization and Processes.

for daily temperature, dry bulb temperature, and wet bulb temperature can be selected at 0.4, 1.0, and 2.0% . The outdoor air condition temperature, relative humidity, and wet bulb temperature was selected from the National Oceanic and Atmospheric Administration at 90 percentile in Table 2.

Table 2

NOAA Climatic Data for Greensboro, NC for Partial and Peak Cooling Day.

STATION GHCND: USW00013723					
TIME	HLY- DEWP- 90PCTL (°F)	HLY- TEMP- 90PCTL (°F)	TIME	HLY- DEWP- 90PCTL (°F)	HLY- TEMP- 90PCTL (°F)
April 10, 2010			July 15, 2010		
8:00	57.9	63.0	8:00	72.0	81.0
9:00	57.9	66.9	9:00	73.0	84.0
10:00	57.9	71.1	10:00	73.0	87.1
11:00	57.9	73.9	11:00	72.0	89.1
12:00	57.2	75.9	12:00	73.0	91.0
13:00	57.0	78.1	13:00	73.0	91.9
14:00	57.9	79.0	14:00	72.0	93.0
15:00	57.0	80.1	15:00	72.0	93.9
16:00	57.0	80.1	16:00	72.0	93.0
17:00	57.0	78.1	17:00	72.0	91.9

Design Airflow: The design airflow is maximum airflow values in which the system must meet demand and ventilation standards or else air starvation occurs.

Constant Values:

Temperature Set-Point of Zone = 72°F
 Design Duct Static Pressure (nominal value) = 2.5
 Chiller Size (extracted from EQuest) = 95 tons

Step 1: Total Airflow Rate

$$Q_Z = q_S / (1.1 * (T_Z - T_S))$$

where: Q_Z = is airflow volume (cfm);
 q_S = is sensible heat units in (Btu/hr)
 T_Z, T_S = are Fahrenheit temperatures for zone and setpoint respectively

This first calculates the zone airflow rates based on the setpoint temperature and sensible load from EQuest.

Step 2: Reheat

$$Reheat = q_S - [1.1 * Q_Z * (T_Z - T_S) * 0.2]$$

where: q_S = is sensible heat units in (Btu/hr);
 Q_Z = is airflow volume (cfm) of zone;
 T_Z, T_S = are Fahrenheit temperatures for zone and setpoint respectively

Reheat is determined if the actual flow rate is less than 20% of designed flow rate. The amount of reheat is determined by the difference of sensible heat necessary to meet 20% design flow. A summation of zones reheats was calculated and converted into electrical energy using the standard of 3410 kbtu/hr equals 1kW.

Step 3: Fan Energy

$$P_T = P_S + C * Q_{SYS}^2$$

where: P_T = is total pressure in (inWg);
 P_S = is static pressure in (inWg);
 C = is flow coefficient
 Q_{SYS} = airflow rate of the system (cfm)

Airflow through a duct system creates three types of pressures: total, static, and dynamic (velocity). Static pressure, P_S , is dependent upon the airflow rate volume and would be a variable input for the algorithm. Fan energy is calculated from the formula: $Pressure_{Total} = Pressure_{Static} + C * (Total\ Airflow\ Rate)^2$. Fan energy consumed in units of kilowatts is the

product of system flow rate times total pressure and power factor divided by motor efficiency

$$W=Q*\Delta P/(6356*n).$$

Step 4: Outside Air Ventilation

$$Q_{OZ} = 20 * P_Z \quad \text{*Version 1989 – 2003}$$

$$Q_{OZ} = (R_P * P_Z) + (R_A * A_Z) \quad \text{*Version 2004- 2013}$$

where: Q_{OZ} = outside airflow rate

R_P = Rate of outdoor airflow per person

P_Z = Population of zone: the number of people in the ventilation zone

R_A = Rate of outdoor airflow per unit area

A_Z = Area of ventilation zone

This is the uncorrected O.A. ventilation determined through ASHRAE Standard 62.1.

Several additional and subsequent algorithms were created to a correction factor for the ventilation rates section. From 1989 to 2003 the minimum outside air was based on occupancy 20 cfm/person for office spaces whereas 2004 to 2013 ventilation rate used occupancy- 5 cfm/person, and zone are- 0.06 cfm/ft² for office spaces.

Table 3

ASHRAE 62.1-1989 to 2003 Table for Outside Air Ventilation

Offices	Est. Max Occupancy per 1000 ft. ²	CFM/ person
Office Space	7	20
Reception Areas	60	15
Data Entry Areas	60	20
Conference Room	50	20

Table 4

ASHRAE 62.1- 2013 Table for Outside Air Ventilation

Offices	People Outdoor Air Rate- R_p (CFM/ Person)	Area Outdoor Air Rate- R_A (CFM/ Sq.Ft)
Main entry Lobbies	5	0.06
Storage Room	5	0.06
Office Space	5	0.06
Reception Areas	5	0.06
Telephone/ Data Entry	5	0.06

The breathing zone outdoor airflow (V_{bz}) is calculated through the following equation given by ASHRAE Standard 62.1- 2004-2013.

Step 5: Basic Calculations & Latent Load

$$q_L = 4840 * Q * W$$

where: q_L = is latent load (btu/hr);

Q = is airflow volume (cfm);

W = humidity ratio difference (lb water/ lb dry air) or (grains water/grains dry air);

7000 grains = 1 lb. water

This calculates the cooling coil energy. Basic calculations assumed the relative humidity leaving the coil was 90%. Depending on the climate, decreasing the latent load may be necessary for thermal comfort. Since this research is located in Climate 4A by ASHRAE Standard 90.1, it is assume dehumidification by air leaving the coil was at 90% relative humidity. Climate Zone 4A is defined as mixed and humid having a CDD base 50°F less than 4500 and

HDD base 65°F between 3600 and 5400 (ASHRAE Fundamentals, 2011). The amount of dehumidification is important because it requires more energy to remove latent energy. The ASHRAE Toolkit 2 provides the energy and algorithm calculations for cooling coil model (Brandemuehl, 1994). The Coiling Coil Method provides a calculation of energy consumption through water pumps, refrigerant compression, and heat transfer of nominal 45°F water chiller temperature to the Air Handling Unit.

Step 6: Chiller Energy (ASHRAE Toolkit 2):

The chiller model is performed using the ASHRAE Toolkit 2 (Brandemuehl, 1994).

Step 7: Total Energy

$$\mathbf{EnergyTotal = ChillerPower + FanPower + Reheat}$$

In the last step, total energy is determined from the summation of three main components: chiller power, supply air fan, and amount of reheat in previous procedures. *See Appendix C: GA Algorithm- VAV Model.*

CHAPTER 5

Results and Analysis of Optimization and Setpoints

5.1 Introduction

In this chapter, the focus is on the results of eQuest's building modeling and load analysis and also the VAV Model results. The effects of using GA and non-optimized, constant variables were analyzed for an entire day in each of the ASHRAE 62.1 ventilation years- 2003 and 2013. Each of the variables was examined for their movement throughout the day. Furthermore two types of days were investigated, the first was peak cooling day and the second was at partial cooling when the load was less. The building load was interpolated for every 15 minutes so that a proposed, conceptual application could later be implemented. Finally we considered the effects of supply air fan pressure on energy and outside air temperature on energy.

5.2 Peak Load

During this study, it was only focused on work-time operational hours allowing the zone temperature to drift away during the unoccupied state. Figure 11 shows the peak cooling loads in each zone on July 15th. It also shows the building load during the day per zone since night time setback is used. By studying the zones responsible for the peak demand, one might also investigate where the most conservations techniques can be applied. Furthermore, night setback is a common low-tech procedure to energy savings where savings with proper controlling in existing buildings can save 10-15% on annual utility cost (Murphy & Maldeis, 2009). We determined an analysis of sensible and total heat during our period of occupancy from 8:00 am (0800 hours) to 5:00 pm (1700 hours).

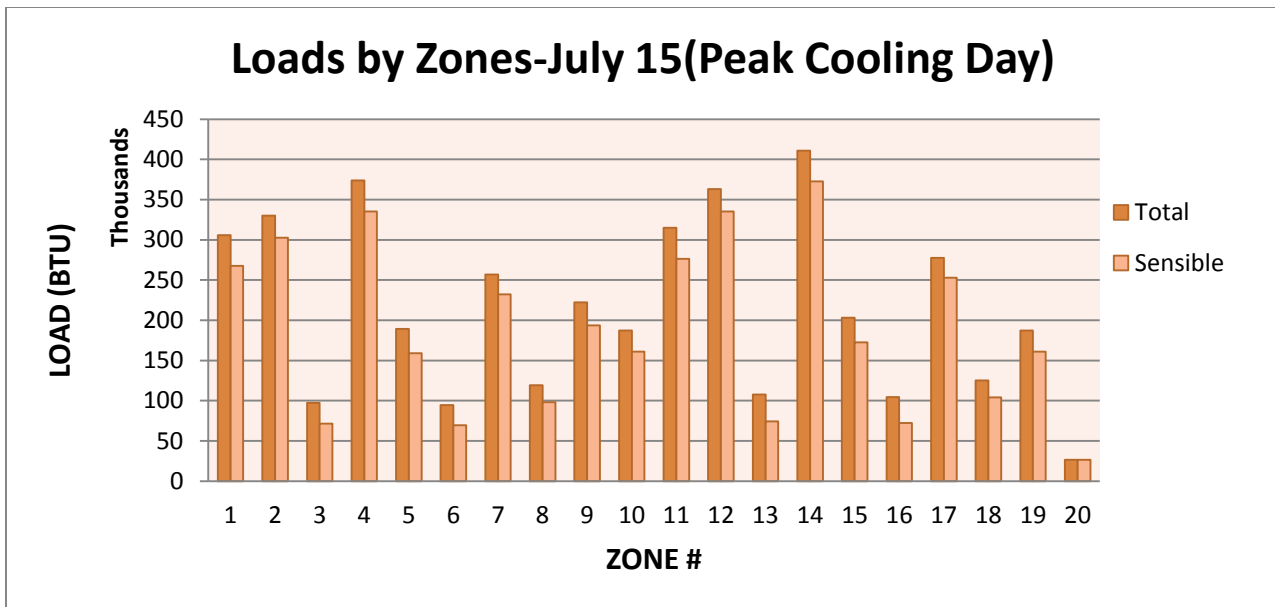

Figure 11. Different Zones Showing Varying Amounts of Loads.

Since 1700 hours is shutoff for the building mechanics, it is not studied. As expected, the building load increases as the amount of daylight hours and people increase but decrease near 4:00pm- when occupants start leaving. Latent load, the difference between total and sensible load, remains relatively proportional until 1600 hours when the work hours is approaching closing in the last hour. Another way to also analyze the load throughout the day is shown in Figure 12 with the whole system cooling load profiles on July 15th.

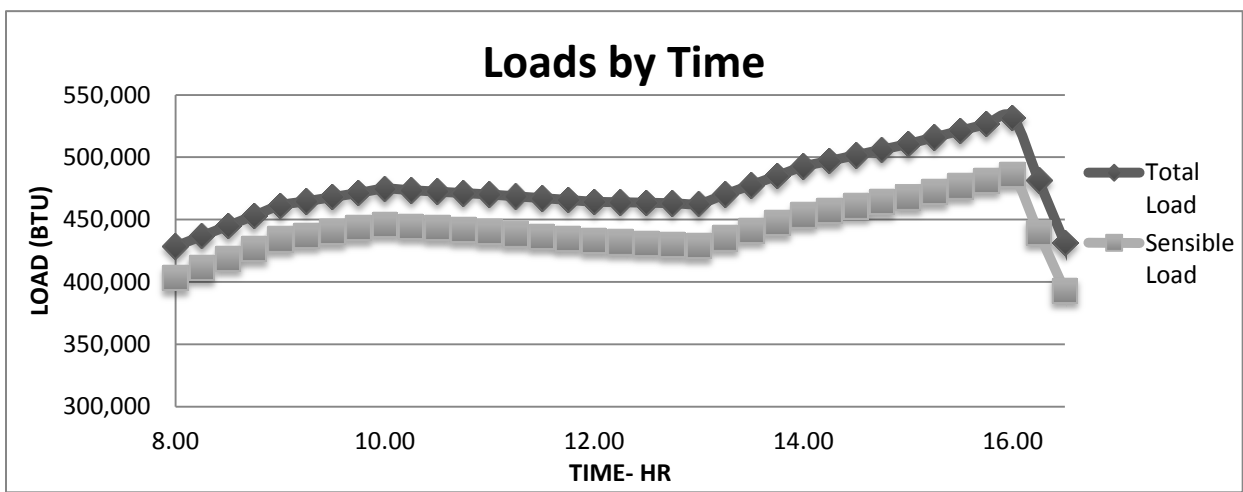

Figure 12. Building Loads Throughout the Day.

In Figure 13, MATLAB provides a simplistic program for GA. Using the command prompt Optimtool, the user is able to calculate the optimal setpoints- in this case supply air temperature and pressure. Further analysis of this program also allows one to change many elements of data hybridization including the number of generations, fitness level, and mutation factor. The energy in Appendix D-F is calculated for every 15 minutes from 8:00am to 5:00pm or 17:00 using the 24 hour format. Since each iteration consists of 15 minutes, this would also mean that 4:45pm would be the last time to be simulated. Two types of tables are first seen at peak load, one with ASHRAE 62.1-2003 and the other ASHRAE 62.1-2013. The partial load was only paired with ASHRAE 62.1 to study the energy and setpoint effects. The peak cooling day was the day of maximum cooling, July 15th whereas the partial load day could be Fall or Spring seasons but arbitrarily chosen to be April 10th.

The screenshot displays the MATLAB Optimtool interface, divided into two main panels: "Problem Setup and Results" and "Options".

Problem Setup and Results:

- Solver:** ga - Genetic Algorithm
- Problem:**
 - Fitness function: @GAHVACModel
 - Number of variables: 2
- Constraints:**
 - Linear inequalities: A: [], b: []
 - Linear equalities: Aeq: [], beq: []
 - Bounds: Lower: [55 1], Upper: [65 3]
 - Nonlinear constraint function: []
- Run solver and view results:**
 - Use random states from previous run
 - Buttons: Start, Pause, Stop
 - Current iteration: 100
 - Clear Results button
- Optimization running:**
 - Objective function value: 51.45014668496799
 - Optimization terminated: maximum number of generations exceeded.
- Final point:**

1	2
55	2.088

Options:

- Population:**
 - Population type: Double Vector
 - Population size: Use default: 20, Specify: 100
 - Creation function: Use constraint dependent
- Initial population:** Use default: [], Specify: []
- Initial scores:** Use default: [], Specify: []
- Initial range:** Use default: [0;1], Specify: []
- Fitness scaling:**
 - Scaling function: Rank
- Selection:**
 - Selection function: Stochastic uniform

Figure 13. Optimtool Simulation Sample for 8:00 am

5.2.1 Peak Load- Supply Air Temperature. Two of the main components that the GA modulates are supply air temperature and pressure. In the Figure 14, the supply air temperature doesn't vary significantly even though the boundary conditions are set to be between 55° and 65°F with only one degree difference at 10:45am and after 4:00pm. Furthermore, this is little change from the constant or actual SAT simulation which was set at constant 55°F during both studies with peak load, Appendix D and E. This was as expected since the system running at peak capacity with a full load. Although the GA searches the entire populations in different combinations, its optimal condition seems to unchanged. The GA was conducted for every 15 minutes with 17:00 hours being dismissed because of its irrational number.

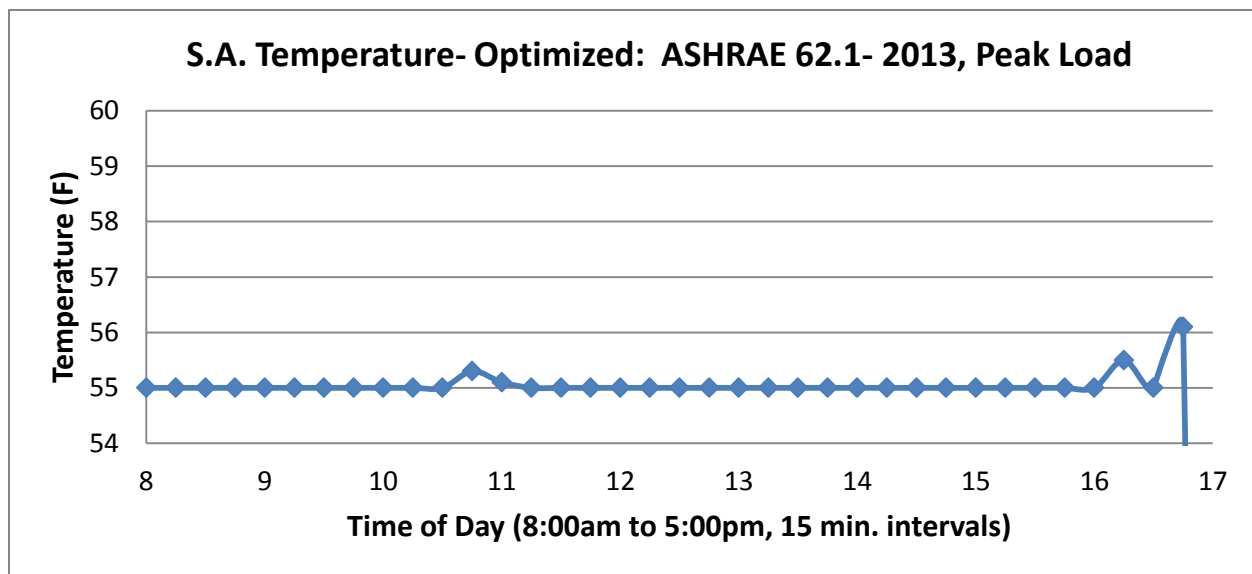

Figure 14. Supply Air Temperature- Optimized, ASHRAE 62.1-2013 at Peak Load.

5.2.2 Peak Load- Supply Air Pressure. The second direct variable modulated was supply air pressure as shown in Figure 15. Compared to S.A. temperature, the pressure was more dynamic throughout the day. The boundary conditions during the GA were from 1.0 inWg to 3.0 inWg. From 08:00 hours, the AHU fluctuate its speed gradually until a peak of 2.7 inWg. The building loads decrease from 9:30 hours to 11:00 hours in which the fan's speed and

pressure decreased. Actual SAP was constant 3.0 inWg when also investigated in the 2013 ventilation codes.

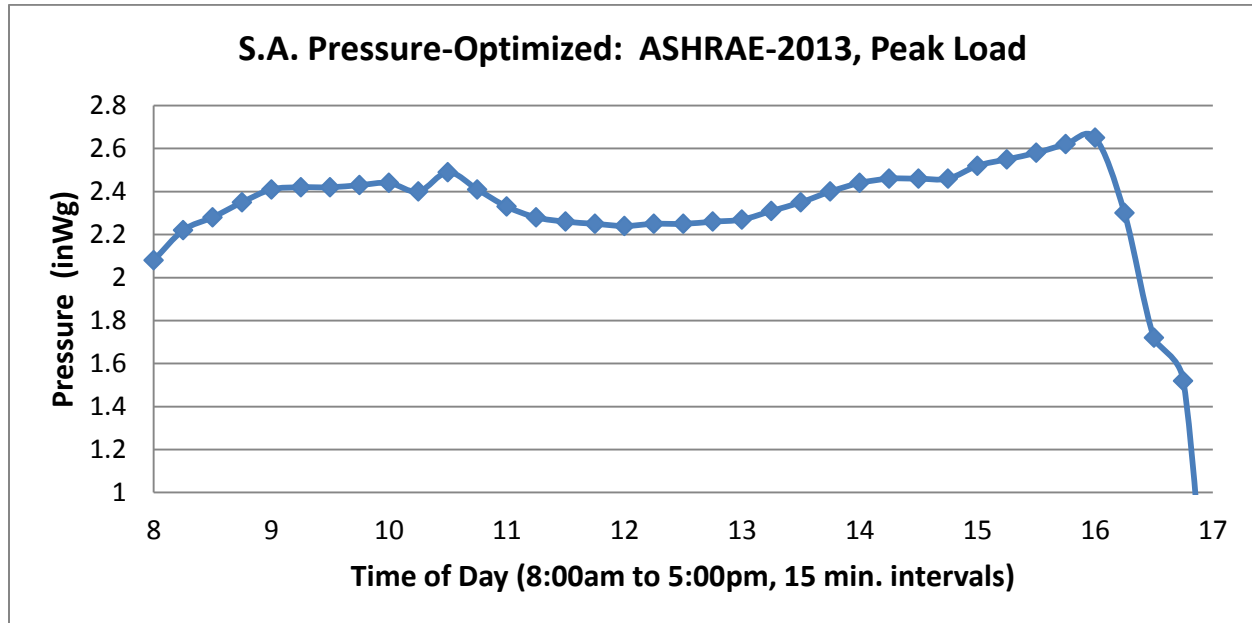

Figure 15. Supply Air Pressure- Optimized, ASHRAE 62.1-2013 at Peak Load.

5.3 Partial Load

Moderate weather conditions particularly in Spring or Fall provides a greater opportunity for energy savings. During these seasons, the time for economizer modes provides a greater opportunity to decrease energy consumption by partially utilizing outside air a means of cooling. Times of partial load are particularly important as there are two moderate seasons and one extreme season for cooling.

5.3.1 Partial Load- Supply Air Temperature. In Figure 16, the supply air temperature decreases linearly until 1:00pm at which it stays constant at 55°F until 4:30pm in which the building load dynamics change with occupants leaving. Not only is there more variation at

partial load than at peak load, but there also very little volatility or sudden big changes in temperature.

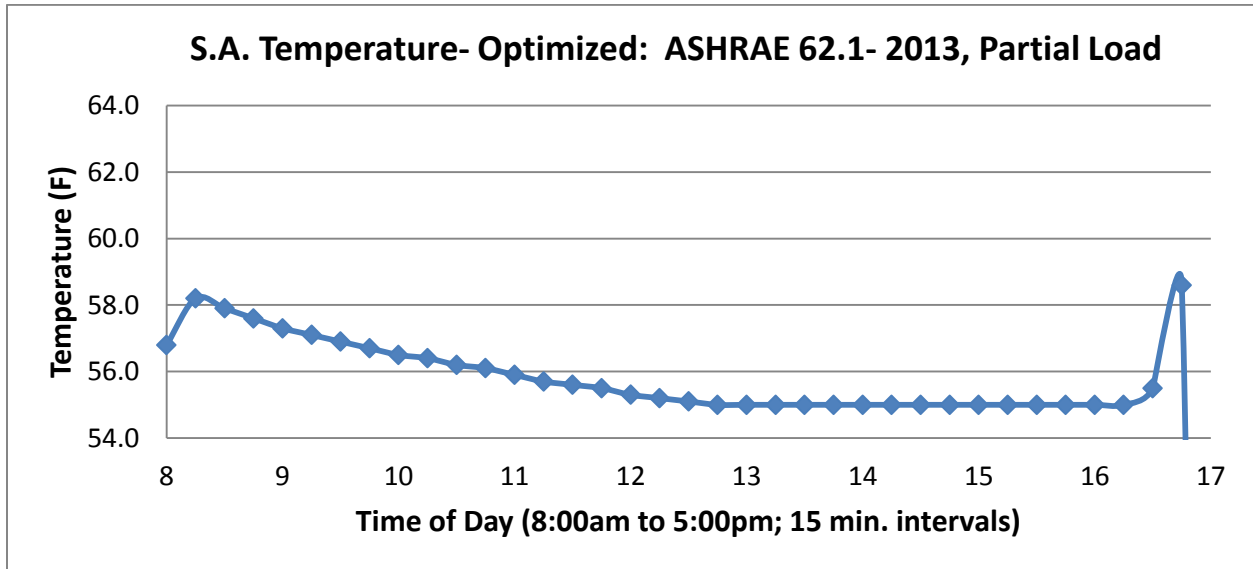

Figure 16. Supply Air Temperature- Optimized, ASHRAE 62.1-2013 at Partial Load.

5.3.2 Partial Load- Supply Air Pressure. In Figure 17, the optimized, supply air pressure at partial load doesn't exceed above 1.80 inWg. The fan speed decreases overall from 8:15am to 1:00pm and fluctuates with some volatility in static pressure.

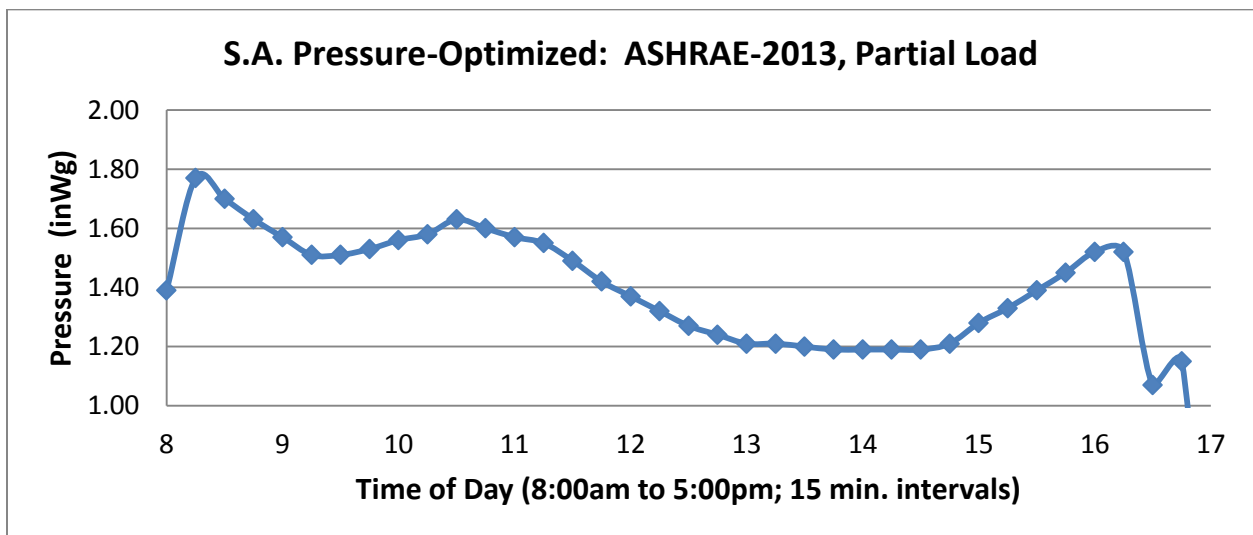

Figure 17. Supply Air Pressure- Optimized, ASHRAE 62.1-2013 at Partial Load.

5.4 Energy Analysis Summary

In earlier chapter figures, the supply air temperature was 55°F whereas during the partial load conditions, there was more variability among the supply air temperature, 55°F-59°F. With more variation, the GA program was able to provide more setpoint combinations during a partial load or economizer which suggest that although genetic is advantageous at peak load, it's more valuable during partial load. In addition, because the supply air is not constantly providing 55°F, there is lesser load on the chiller and thus lesser energy consumption.

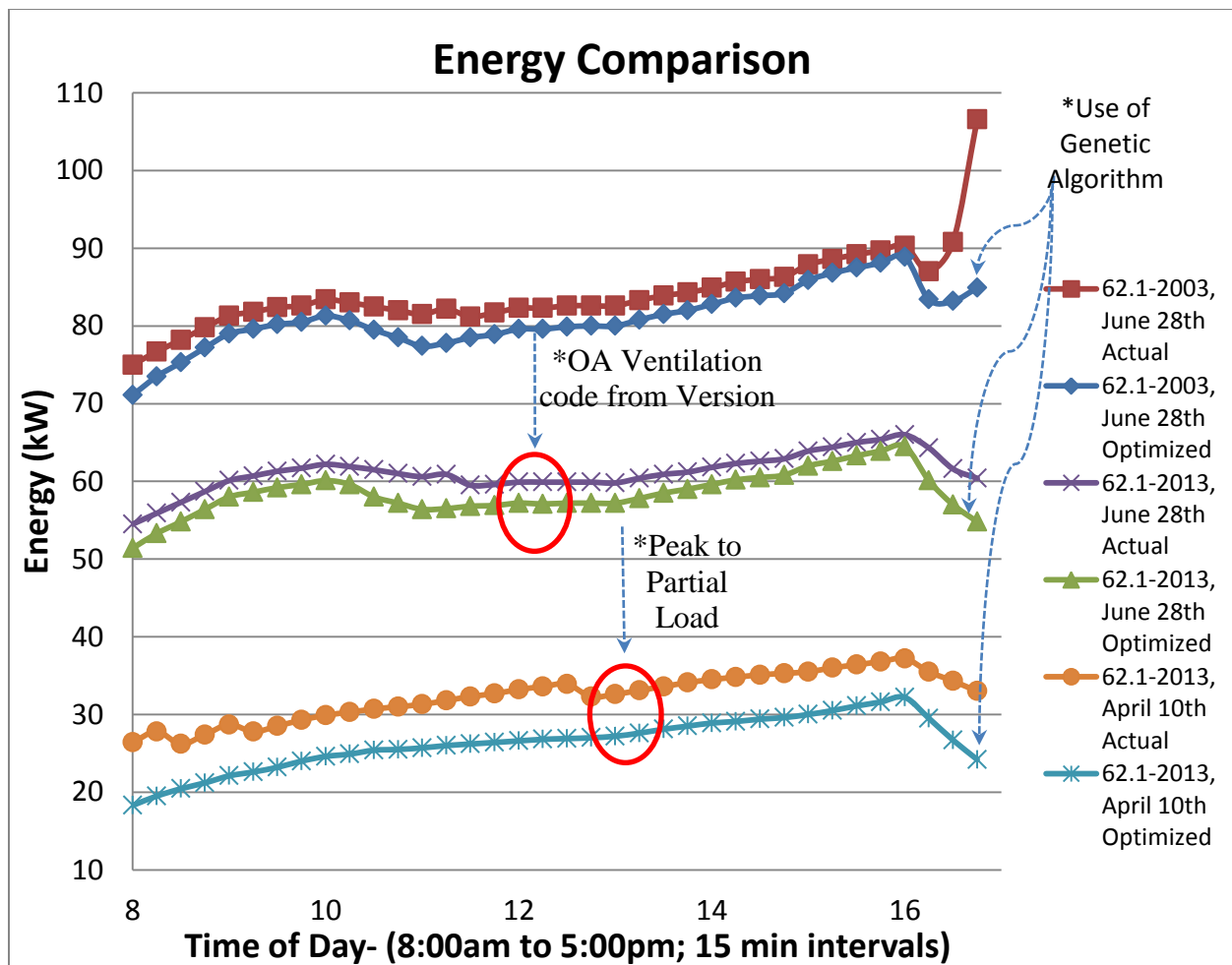

Figure 18. Actual Energy Demand

Shown in Figure 18 is the energy consumption for both the constant and optimized supply air temperature and pressure. The ventilation rates energy demand can be analyzed by studying the top four data plot lines. Separately, to compare energy demand at peak and partial load, the last four data plot lines can be examined. Again, peak load was conducted on July 15th while partial load was conducted on April 10th. Lastly, the energy demand can be conducted in comparison between non-optimized or constant setpoints versus optimized by comparing the first two top lines, next two middle trends, and the last bottom two in sets.

5.4.1 Ventilation Rates: ASHRAE 62.1. An analysis of the ventilation rates can be made using the first four data trend lines in Figure 17. When comparing both averages of optimized versus constant in each case of utilizing 2003 or 2013 ventilation rates, the savings are significant. When comparing 2003 versus 2013 peak load's energy consumption, the impact was major. By using ASHRAE 62.1-2013, the savings was approximately 24.0 kW.

5.4.2 Peak versus Partial Load. The effect of peak load against partial load, only the last bottom four trends in Figure 17 are studied. Overall the partial load on April 10th consumes lesser energy than peak load on July 15^h. This is due to more moderate temperatures in Spring than Summer. In the constant setpoints, the peak cooling day averaged 61.1 kW whereas the partial load day was 32.3 kW. However in the optimized setpoint, the peak cooling day averaged 58.4 kW while partial load averaged 26.3 kW. This is a drastic savings but April 10th temperature was very moderate and thus gave an economizer opportunity.

5.4.3 Optimized versus Non-Optimized Setpoints: Genetic Algorithm. During investigating the optimized versus non-optimized setpoints effects, a relationship between first top two trends, next middle two trends, and last two bottom trends were examined separately.

The optimized strategy used in conjunction saves approximately 3.0 kW per minute in both peak load cases of ASHRAE 62.1-2009 and 2013. There is however a bigger energy difference between optimized and non-optimized at partial load, approximately 5.0 kW saved, thus inferring that GA is more beneficial during economizer periods.

When totaled over the whole day, the savings could be significant. Two primary contributing factors leads to significant difference between 2003 Non-Optimized and 2013 Optimized energy difference. Application of GA to find the optimum variables and updated ventilation standards were big sources of the energy savings and especially at partial loads. When comparing energy savings independently due to GA and ventilation codes, the GA has a small but considerable effect but not as much as compared to using modern ventilation standards. ASHRAE 62.1-2013 saves a tremendous amount of energy just by specifying the amount of people and zone size depending on type of building. There was also an optimized energy difference between the peak load and partial load conditions. The partial-load energy consumption was between 18-37 kW whereas peak load energy consumption was between 51-66 kW, depending on constant or optimized setpoints

Other technologies and strategies can also be implemented to improve the energy savings. Although the study only focused on the occupants work hours, it can also be studied throughout the day where strategies such as pre-cooling the building can be utilized. Pre-cooling works with the physical mass of building to store thermal mass. It offer potentials of chiller efficiency during the night and reduced electricity consumption during off-peak periods (Roth, Dieckmann, & Brodrick, 2009).

5.5 Fan Laws

Besides the supply air temperature reset, the supply air fan was a primary contributing variable in energy consumption. With new innovations and standards, fan efficiency will be a leading factor in energy guidelines. ASHRAE Standard 90.1-2013 has implemented new regulations following Air Movement and Control Association, AMCA 205 classifications for efficient fans and its implementation. AMCA 205 determines the Fan Efficiency Grade, FEG, and is based upon two main factors: fan's aerodynamic ability to convert shaft or impellor power of direct driven fan to air power and sizing, selection to be within 15% of the peak fan total efficiency (Cermak, 2013).

The supply air fan is one major aspect to energy conservation and could be shown through the Fan Laws or relationship between volume flow rate and fan speed independently. In the below example of increasing the supply air volume flow rate 25% , from 10,000 CFM to 12,500 CFM with the following variables $CFM_1 = 10,000$; $SP_1 = 1.50$ inWG; and $RPM_1 = 1,000$. According to the fan laws, the fan power has to increase and use energy at a faster rate to the third power as the volume flow rate increases. To increase volume flow rate 25% from 1000 CFM to 1250 CFM, it would almost double the power necessary.

Fan Law Equations

$$CFM_2 = \left(\frac{RPM_2}{RPM_1}\right) * CFM_1$$

$$SP_2 = \left(\frac{RPM_2}{RPM_1}\right)^2 * SP_1$$

$$HP_2 = \left(\frac{RPM_2}{RPM_1}\right)^3 * HP_1$$

Where CFM = cubic feet per minute;

RPM = revolutions per minute;

SP =static pressure;

HP = horsepower; 1HP=746 Watts

and subscript 1= initial, subscript 2=new.

$$\text{Example: } HP_2 = \left(\frac{1250}{1000}\right)^3 * 5.00 = 9.77 \text{ HP}$$

Thus decreasing fan static pressure by allowing to vary using reset controllers decreases energy consumption such as use of motor' variable frequency drives. During the peak and partial load optimization, the supply varied throughout the day in the study.

5.6 Outside Air Ventilation

Using an ASHRAE psychrometric in Figure 18, the energy consumption between outside air and mixed air can be evaluated. As mixed air, MA, becomes a larger proportion of outside air, OA, the enthalpy difference between (h_2) and (h_1) becomes more wide and thus uses more energy. The mixed air proportion can be calculated through the conservation of mass where return air plus outside air equal mixed air. Mixed air passes through the cooling coil and

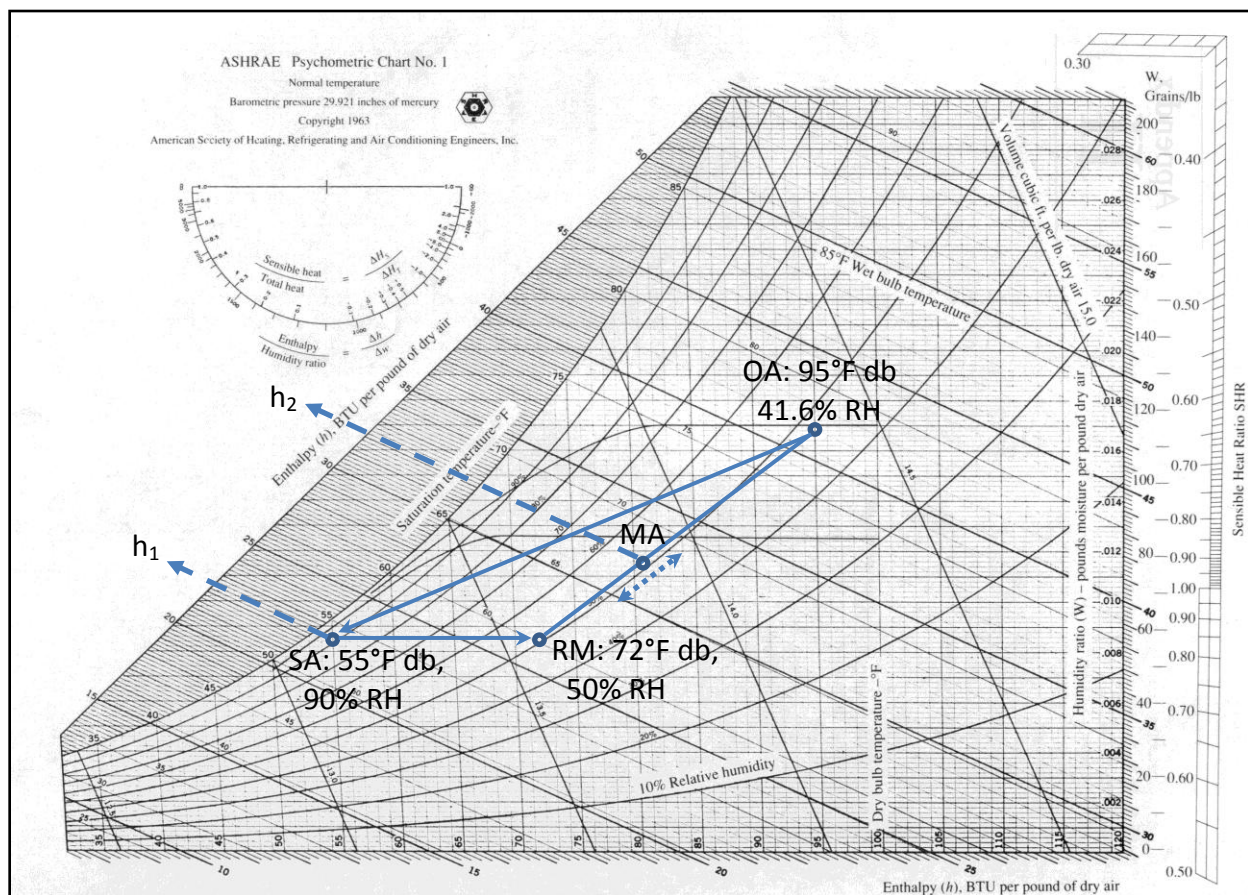

Figure 19. Psychrometric of Outside Air's Effect on Mixed Air and Enthalpy. (ASHRAE, 1963).

becomes supply air in the physical and theoretical models. When the MA is majority return air, it uses less energy during seasons with extreme temperatures such as summer. However, in Spring, Fall, or mornings, the situation may be different when outside air conditions are moderate or favorable and the HVAC system can enter economizer mode and thus allow moderate supply air to the HVAC system. The outside air can be used more to cool and ventilate the space and thus decrease the load upon the cooling coil valves and compressor.

CHAPTER 6

CONCLUSION

6.1 Introduction

The use of any models must include real-world challenges, possible resolutions, and where future opportunities may exist. The value of these models carries much opportunity for usage in other automations systems. A system can become more efficient when inclusive of additional processes and variables the such as chiller and water-side operations when used for GA.

6.2 Constraints & Boundaries

The GA program randomly selects points between these two variables in different combinations for energy analysis. Should the variables setpoints be determined to use excess energy, the program penalizes the data selection for non-fitness and selects a new, randomized variables into the next generation. Setpoint variables that cannot exist simultaneously together or jointly are also constrained and penalized by amplifying the energy consumption resulting in non-fit setpoints. Furthermore, should the VAV program run a cycle or generation which airflow rate of the zone is higher than designed, then it is penalized. The expression of airflow rate penalty is : if $Q_z(i) > Q_{zd}(i) * (P_s/P_{sd})^{0.5}$ then Constraints = 1. In Figure 19, if the airflow rate is higher than design, it will create a penalty per zone.

have adequate cooling. Should the system starve any zones, the rooms will fluctuate a higher temperature to possibly 74°F but not any higher.

Upper and lower bound during the GA was bounded between 1.0 and 3.0 inWg for the supply air pressure. The supply air temperature was also limited between 55°F and 65°F. However during the constraints, when the GA process selected a set of setpoints that created a higher airflow than designed as shown in Figures 20 and 21 the particular zones was automatically set to have to have 10,000 kW but not more than the maximum zones allowed by constraint. The control logic tries to aim to meet all areas but in this case it was not possible to having three zones at most to over or undersupply air. The zones may be under or oversupplied but this okay in this situation, as the minimum or maximum supply air pressure will still be 1.0 and 3.0 inWg respectively- at no times will there not be no airflow, starving, or surging as limited by the boundary conditions.

Other optimized components such as the supply air temperature reset can be limited by 60°F but at the cost of undercooling zones or under-dehumidifying. At the other spectrum of lowering SAT reset temperature 44°F to 54°F, the fan energy can reduced and also allowing more dehumidification capability but at the cost of thermal comfort when dumping cold directly on occupants, condensation at the terminal zones, or icing of the coiling coils (Murphy, 2011).

6.3 Application

Proposed Application Logic: Because of volatility within GA, the supply air pressure would to never move more than 0.2 to 0.5 inWg per 15 minutes which would cause instability because of big, sudden changes. The changes in temperature would also involve the previous data if there was already an increase or decrease in demand for pressure. If there was already in increase in

pressure, then it would instead move 1inWg per 15 minutes thus moving at a faster response and if it was a previous decrease followed by a increase, then it would move with normal operation at 0.5 inWg per 15 minutes. The default or err status also would move at a maximum of 3.0 inWg with a flagged signal to operator. The minimum at which it would shut off beyond these extremes is 1.0 inWg and maximum air fan pressure of 3.0.

Proposed Application Logic: The supply air temperature would follow the same strategy also to never move more than 1°F per 15 minutes which would cause instability because of big, sudden changes. The changes in temperature would also involve the previous data if there was already an increase or decrease in demand for pressure. If there was already an increase in pressure, then it would instead move 2°F per 15 minutes thus moving at a faster response and if it was a previous decrease followed by an increase, then it would move with normal operation at 1°F per 15 minutes. The default or err status also would move at a minimum of 55°F with a flagged alarm to operator. The minimum at which it would shut off beyond these extremes is 51°F and maximum of 66°F.

6.4 Future Research

GA provides an opportunity for other areas of research. During the simulation it was conducted at steady state, so with a dynamic state with time changes per week and month, there are more parameters. The central plant also has setpoint such as water temperatures that can be added as variables which also leads to condenser plants. Condensers have the role of heat removal and is only as effective as the ambient temperatures outside which becomes really dynamic throughout the year. During this study we used the default settings of GA which is used for all general cases but having a more tuned, improved model applicable to HVAC may provide

better case studies. With improved models, we can also further our studies in real-time testing. The list is endless as where GA is applicable such as the growing use of variable refrigerant flow, VRVs, or buildings with multimode, different types of systems. In addition, not only can GA provide better studies in HVAC but economic studies, mechanical design layouts, facility operations, and diagnoses for particular zones that are erroneously designed. While the overall goal overall was to decrease energy consumption was the main focus, several other important strategies was uncovered. These savings could be adjusted for higher returns when factoring in buildings running at above baselines particularly in old buildings or where HVAC systems may be timeworn. With many contributing factors deciding the actual energy consumption that were held constant during the sequencing method such as the coiling coils, outside air, number of people and their activity, chiller, and condenser operations, a more energy savings could be developed with more variables.

Advances in building automation systems allows for other benefits during implementations of reset controllers. Fan-pressure optimization allows for the identification of rogue zones in which a specific zone is not working properly causing high loads that can be regulated (Murphy, 2011). Furthermore, faults or improper working VAVs and equipment can significantly impact energy conservation. Artificial intelligence can be utilized to find faults such as relying upon the sensory and control signal data available in building management control systems (BMCS) (Wang, Chen, Chan, & Qin, 2012).

REFERENCES

1. Aktacir, M., Buyukalaca, O., & Yilmaz, T. (2006). Life-Cycle Cost Analysis for Constant Air Volume and Variable Air Volume Air-Conditioning Systems. *Applied Energy*, 83(6), 606-627. Turkey: Elsevier.
2. ASHRAE Handbook. (2011). *Heating, Ventilating, and Air-Conditioning Applications*. Atlanta: American Society of Heating, Refrigerating and Air-Conditioning Engineers, Inc. Retrieved from <https://www.ashrae.org/resources--publications/handbook>
3. ASHRAE Handbook. (2011). *Heating, Ventilating, and Air-Conditioning Fundamentals*. Atlanta: American Society of Heating, Refrigerating and Air-Conditioning Engineers, Inc. Retrieved from <https://www.ashrae.org/resources--publications/handbook>
4. Attaway, S. (2012). *MATLAB: A Practical Introduction to Programming*. Oxford: BH.
5. Brandemuehl, M.J. (1994). Development of a Toolkit for Secondary HVAC System Energy Calculations. *ASHRAE Transactions*, 100(1), 21-32. Atlanta: ASHRAE.
6. Cermak, J. (2013). Fan Efficiency Requirements For Standard 90.1-2013. *ASHRAE Journal*, 55(4), 24-30. Atlanta: ASHRAE.
7. Chen, W., & Deng, S. (2006). Development of a dynamic model for a DX VAV Air Conditioning System. *Energy Conversion and Management*, 47(18-19), 2900-2984. Hong Kong: Elsevier.
8. Chipperfield, A. (2004). Genetic Algorithm Toolbox User's Guide- V1.2. *Dept. of Automatic Control and Systems Engineering- University of Sheffield*. Massachusetts: The MathWorks.
9. Dieckmann, J., Cooperman, A., & Brodrick, J. (2012). Energy Efficiency in a Box. *ASHRAE Journal*, 54(4), 88-92. Atlanta: Georgia.
10. Dieckmann, J., McKenney, K., & Brodrick, J. (2009). Energy-Efficient Dehumidification. *ASHRAE Journal*, 51(8), 78-80. Atlanta: ASHRAE.

11. Energy Information Administration. (2012). *Annual Energy Review*. Retrieved from <http://www.eia.gov/consumption/>
12. Energy Information Administration. (2012). *Effect of Increased Natural Gas Exports on Domestic Energy Markets*. Retrieved from <http://www.eia.gov/consumption/>
13. *eQuest Introductory Tutorial* v3.63. (2009). James J. Hirsch & Associates. California: Lawrence Berkeley National Laboratory.
14. Emmerich, S. (2011). Standard 62.2 Update. *ASHRAE Journal*, 53(1), 62-65. Atlanta: ASHRAE.
15. Goldberg, D. E. (1989). *Genetic Algorithm in Search, Optimization, and Machine Learning*. Canada: Addison.
16. Hastbacka, M., Dieckmann, J., and Bouza, A., (2013). ERV Technology Revisited. *ASHRAE Journal* 55(1), 65-68. Atlanta: ASHRAE.
17. Karunakaran, R., Iniyar, S. and Goic, R. (2010). Energy Efficient Fuzzy Based Combined Variable Refrigerant Volume and Variable Air Volume Based Air Conditioning System for Buildings. *Applied Energy*, 87(4), 1158-1175. India: Elsevier.
18. Kissell, T. (2008). *Electricity, Electronics, and Control Systems for HVAC*. Pearson.
19. Ke, Y.P., & Mumma, S.A. (1997). Optimized Supply-Air Temperature (SAT) in Variable Air Volume (VAV) Systems. *Energy* 22(6):601-614. Pennsylvania: Elsevier.
20. Mathworks. *MATLAB: Global Optimization Toolbox- Genetic Algorithm*. 2013. Retrieved from <http://www.mathworks.com/products/global-optimization/>
21. McDowall, R. (2007). Chapter 4- Ventilation and Indoor Air Quality. *Fundamentals of HVAC Systems*, 45-61. Atlanta: ASHRAE.

22. Mumma, S.A. (2009). 30% Surplus OA- Does It Use More Energy? *ASHRAE Journal*, 51(6), 24-36. Atlanta: ASHRAE.
23. Murphy, J. (2011). High-Performance VAV Systems". *ASHRAE Journal*, 53(10), 18-28. Atlanta: ASHRAE.
24. Murphy, J., & Maldeis, N. (2009). Using Time Of Day Scheduling to Save Energy. *ASHRAE Journal*. 51(5), 42-48. Atlanta: ASHRAE.
25. Nassif, N. (2010). Performance Analysis of Supply and Return Fans for HVAC Systems Under Different Operating Strategies of Economizer Dampers. *Energy and Buildings*, 42(7), 1026-1037. Florida: Elsevier.
26. Nassif, N., Kaji, S., & Sabourin R. (2005). Optimization of HVAC Control System Strategy Using Two-Objective Genetic Algorithm. *HVAC&R Research*, 11(3), 459-486. Atlanta: ASHRAE.
27. Page, S. (2011). System Effect. *ASHRAE Journal*, 53(6), 38-41. Atlanta: ASHRAE.
28. Perez-Lombard, L.; Ortiz, J., & Pout, C. (2008). A Review on Buildings Energy Consumption Information. *Energy and Buildings*, 40(8), 394-398. Spain: Elsevier.
29. Reindl, D., & Jekel, T. (2009). Frost on Air-Cooling Evaporators. *ASHRAE Journal*, 51(2),27-33. Atlanta: ASHRAE.
30. Roth, K., Dieckmann, J., & Brodrick, J. (2009). Using Off-Peak Precooling. *ASHRAE Journal*, 51(3). Atlanta: ASHRAE.
31. Sekhar, C. (2013). Good Humidity Control. *ASHRAE Journal*, 55(1), 68-71. Atlanta: ASHRAE.
32. Stanke, D. (2010). Dynamic Reset for Multiple-Zone Systems. *ASHRAE Journal*, 52(3), 22-35. Atlanta: ASHRAE.
33. Stein, J., & Taylor, S. (2013). VAV Reheat Versus Active Chilled Beams. *ASHRAE Journal*, 55(5), 18-32. Atlanta: ASHRAE.
34. Taylor, S.T. (2007). Increasing Efficiency with VAV System Static Pressure Setpoint Reset. *ASHRAE Journal*, 49(6), 24-32. Atlanta: ASHRAE.

35. Taylor, S., Stein, J., & Paliaga, G. (2012). Dual Maximum VAV Box Control Logic.” *ASHRAE Journal*, 54(4), 16-24. Atlanta: ASHRAE.
36. U.S. DOE. (2008). *The 2008 Building Energy Databook*. Washington, D.C.: U.S. Department of Energy. 2008.
37. U.S. Energy Information Administration 2010. (2012). Annual Energy Review 2011. Washington, DC.: US-EIA.
38. *U.S. Green Building Council*. Leadership in Energy and Environmental Design. Retrieved from <http://www.usgbc.org>
39. Wang, S., and Xu, X. (2002). A Robust Control Strategy for Combining DCV Control with Economizer Control. *Energy Conversion and Management*, 43(18), 2569-2588. Hong Kong: Elsevier.
40. Wang, H., Chen, Y., Chan, C., & Qin, J. (2012). An Online Fault Diagnosis Tool of VAV Terminals for Building Management and Control Systems. *Automation in Construction*. 22, 203-211. China: Elsevier.
41. Xu, X., Wang, S., Sun, Z., & Xiao, F. (2009). A Model-Based Optimal Ventilation Control Strategy of Multi-Zone VAV Air-Conditioning Systems. *Applied Thermal Engineering*, 29, 91-104. Hong Kong: Elsevier.
42. Yao, Y., Lian, Z., Liu, W., Hou, Z., & Wu, M. (2007). Evaluation Program for the Energy-Saving of Variable Air Volume Systems. *Energy and Buildings*, 39(5) 558-568. China: Elsevier.
43. Yao, Y. & Wang, L. (2010). Energy Analysis on VAV System with Different Air-Side Economizer in China.” *Energy and Buildings*, 42(8), 1220-1230. China: Elsevier.

Appendix A: eQuest Data

C:\Users\TonyNuge\Desktop\RESEARCH\EQuest 1\Research Project - Baseline Design

Simulated: 2012-May-18 09:59:38

CSV Written: 2012-May-18 09:59:38

JULY 15- Peak Cooling

eQUEST

3.64.7130

Hourly Report									
				EM1 Hourly Report Block		Hourly Report Block 2		Hourly Report Block 3	
				SPACE		SPACE		SPACE	
				SE Space (fG.s1)		NE Space (fG.s10)		Cor Space (fG.s3)	
			Day	Var 42	Var 44	Var 42	Var 44	Var 42	Var 44
7	15	8	6	8760.24	8760.24	19622.3	19622.3	1234.94	1234.94
7	15	9	6	11280.1	11280.1	24570.5	24570.5	1202.75	1202.75
7	15	10	6	13122.5	13122.5	27631.2	27631.2	1167.22	1167.22
7	15	11	6	14216.4	14216.4	27316.3	27316.3	1128.23	1128.23
7	15	12	6	15319.5	15319.5	25343	25343	1093.16	1093.16
7	15	13	6	18219.5	18219.5	23288.3	23288.3	1058.15	1058.15
7	15	14	6	23341.7	23341.7	22465.1	22465.1	1024.99	1024.99
7	15	15	6	26186.4	26186.4	23332.2	23332.2	995.454	995.454
7	15	16	6	28113.9	28113.9	22574.3	22574.3	963.672	963.672
7	15	17	6	26461.4	26461.4	20909.2	20909.2	929.914	929.914

Hourly Report Block 4		Hourly Report Block 5		Hourly Report Block 6		Hourly Report Block 7		Hourly Report Block 9	
SPACE		SPACE		SPACE		SPACE		SPACE	
NW Space (fG.s2)		WNW Space (fG.s4)		Cor Space (fG.s5)		SE Space (fG.s6)		SW Space (fG.s9)	
Var 42	Var 44	Var 42	Var 44	Var 42	Var 44	Var 42	Var 44	Var 42	Var 44
26135.4	26135.4	7324.23	7324.23	1199.8	1199.8	8992.56	8992.56	7044.92	7044.92
28846.8	28846.8	7907.8	7907.8	1168.53	1168.53	12998.5	12998.5	9143.2	9143.2
28117.7	28117.7	7852.33	7852.33	1134.01	1134.01	15620.3	15620.3	10670.5	10670.5
24038.1	24038.1	7088.85	7088.85	1096.13	1096.13	17012.7	17012.7	11451.8	11451.8
20918.4	20918.4	6591.2	6591.2	1062.05	1062.05	17938.6	17938.6	12048	12048
20248.7	20248.7	6530.8	6530.8	1028.04	1028.04	19278	19278	12751.5	12751.5
19303.5	19303.5	6421.28	6421.28	995.824	995.824	22626.8	22626.8	13111.8	13111.8
20175.7	20175.7	6817.34	6817.34	967.125	967.125	25209.8	25209.8	16102	16102
19023.4	19023.4	6885.35	6885.35	936.248	936.248	27244.6	27244.6	19678.8	19678.8
17719.1	17719.1	6793.15	6793.15	903.45	903.45	26561.6	26561.6	21562.7	21562.7

Hourly Report Block 4 SPACE		Hourly Report Block 5 SPACE WNW Space		Hourly Report Block 6 SPACE		Hourly Report Block 7 SPACE		Hourly Report Block 9 SPACE	
NW Space (fG.s2)		(fG.s4)		Cor Space (fG.s5)		SE Space (fG.s6)		SW Space (fG.s9)	
Var 42	Var 44	Var 42	Var 44	Var 42	Var 44	Var 42	Var 44	Var 42	Var 44
26135.4	26135.4	7324.23	7324.23	1199.8	1199.8	8992.56	8992.56	7044.92	7044.92
28846.8	28846.8	7907.8	7907.8	1168.53	1168.53	12998.5	12998.5	9143.2	9143.2
28117.7	28117.7	7852.33	7852.33	1134.01	1134.01	15620.3	15620.3	10670.5	10670.5
24038.1	24038.1	7088.85	7088.85	1096.13	1096.13	17012.7	17012.7	11451.8	11451.8
20918.4	20918.4	6591.2	6591.2	1062.05	1062.05	17938.6	17938.6	12048	12048
20248.7	20248.7	6530.8	6530.8	1028.04	1028.04	19278	19278	12751.5	12751.5
19303.5	19303.5	6421.28	6421.28	995.824	995.824	22626.8	22626.8	13111.8	13111.8
20175.7	20175.7	6817.34	6817.34	967.125	967.125	25209.8	25209.8	16102	16102
19023.4	19023.4	6885.35	6885.35	936.248	936.248	27244.6	27244.6	19678.8	19678.8
17719.1	17719.1	6793.15	6793.15	903.45	903.45	26561.6	26561.6	21562.7	21562.7

Hourly Report Block 8 SPACE			Hourly Report Block 10 SPACE		Hourly Report Block 11 SPACE		Hourly Report Block 12 SPACE		Hourly Report Block 13 SPACE Cor Space
SW Space (fG.s7)			NE Space (fG.s8)		SE Space (fT.s1)		NE Space (fT.s10)		(fT.s3)
Var 42	Var 43	Var 44	Var 42	Var 44	Var 42	Var 44	Var 42	Var 44	Var 42
2769.09	0	2769.09	7412.46	7412.46	7870.62	7870.62	18751.5	18751.5	866.417
3202.31	0	3202.31	9264.29	9264.29	10231.7	10231.7	24154.4	24154.4	826.694
3509.77	0	3509.77	10701.1	10701.1	12028.9	12028.9	27897.7	27897.7	787.035
3662.01	0	3662.01	10927.2	10927.2	13234.4	13234.4	28387.3	28387.3	746.831
3772.93	0	3772.93	10189.6	10189.6	14507.6	14507.6	27161	27161	713.016
3909.06	0	3909.06	8790.4	8790.4	17626.5	17626.5	25699.2	25699.2	681.365
3972.4	0	3972.4	7786.23	7786.23	22990.1	22990.1	25333	25333	653.315
4582.58	0	4582.58	7794.53	7794.53	26028.3	26028.3	26385.8	26385.8	630.348
5369.07	0	5369.07	7342.84	7342.84	28507	28507	25777.3	25777.3	606.343
5874.71	0	5874.71	6820.53	6820.53	27827.6	27827.6	24181.6	24181.6	581.341

	Hourly Report Block 14 SPACE NW Space (fT.s2)		Hourly Report Block 15 SPACE WNW Space (fT.s4)		Hourly Report Block 16 SPACE Cor Space (fT.s5)		Hourly Report Block 17 SPACE SE Space (fT.s6)		Hourly Report Block 18 SPACE SW Space (fT.s7)
Var 44	Var 42	Var 44	Var 42	Var 44	Var 42	Var 44	Var 42	Var 44	Var 42
866.417	24300.4	24300.4	6907.13	6907.13	841.757	841.757	9311.5	9311.5	2550.91
826.694	27667.8	27667.8	7613.66	7613.66	803.164	803.164	12894.8	12894.8	2963.98
787.035	27838.6	27838.6	7725.58	7725.58	764.634	764.634	15835.7	15835.7	3275.42
746.831	24759.3	24759.3	7134.11	7134.11	725.574	725.574	17553.2	17553.2	3451.38
713.016	22454.5	22454.5	6770.93	6770.93	692.722	692.722	18546.1	18546.1	3598.69
681.365	22237	22237	6809.07	6809.07	661.972	661.972	20244.6	20244.6	3778.2
653.315	21546.3	21546.3	6754.37	6754.37	634.72	634.72	23874	23874	3889.32
630.348	22416.1	22416.1	7198.53	7198.53	612.407	612.407	26999.5	26999.5	4551.09
606.343	21266.3	21266.3	7305.86	7305.86	589.085	589.085	29464.1	29464.1	5407.45
581.341	19885.3	19885.3	7254.02	7254.02	564.794	564.794	29248.3	29248.3	6009.27

	Hourly Report Block 19 SPACE NE Space (fG.s8)		Hourly Report Block 20 SPACE SW SpcPlen (fT.s9)	
Var 44	Var 42	Var 44	Var 42	Var 44
2550.91	7412.46	7412.46	191.031	191.031
2963.98	9264.29	9264.29	786.753	786.753
3275.42	10701.1	10701.1	1529.22	1529.22
3451.38	10927.2	10927.2	2257.3	2257.3
3598.69	10189.6	10189.6	2988.23	2988.23
3778.2	8790.4	8790.4	3639.61	3639.61
3889.32	7786.23	7786.23	4141.69	4141.69
4551.09	7794.53	7794.53	4701.15	4701.15
5407.45	7342.84	7342.84	4967.46	4967.46
6009.27	6820.53	6820.53	5011.36	5011.36

```

32
33 -   Tz=72*ones(size(Qzd,1),1); % Assume all zone temperature set point is 72oF
34
35 -   C=Properties(1);
36 -   Eff=Properties(2);
37 -   Rp=Properties(3);
38 -   Ra=Properties(4);
39
40   %Step 1: zone airflow rates (through LOADS)
41 -   Qz=qs./(1.1*(Tz-Ts));
42
43   % Step 2: Reheat; don't confuse Reheat vs the VAV Process
44 -   for i=1:size(Qz,1)
45 -       if Qz(i)<0.2*Qzd(i) %If Flow Loads < 20% Flow Design, then Reheatz:
46 -           %then Load Heat minus 20% Design Heat = Reheat of Individul Zones
47 -           Reheatz(i)=qs(i)-(1.1*Qz(i)*(Tz(i)-Ts)*0.2);
48 -           Reheatz(i)=Reheatz(i)/3410; %to get kW of individual zones
49 -           Qz(i)=0.2*Qzd(i); %Qz is NOW minimum Design value
50 -       else
51 -           Reheatz(i)=0;
52 -       end
53 -   end
54 -   Reheat=sum(Reheatz);
55
56   %Step 3: fan power
57 -   Qsys=sum(Qz);
58 -   Pt=Ps+C*(Qsys)^2;
59 -   FanPower=Pt*Qsys/(6356*Eff)*0.74;
60
61   %Step 4: Outdoor air flow according to ASHRAE 62.1 2010 procedure
62 -   Qoz=Rp*Pz+Ra*Az;% for actual operation use:
63   %Qoz=20*Pz; %Must also research old ASHRAE 62 standards!!!

```

```

64 - Qox=sum(Qoz); % not corrected
65 - Xs=Qox/Qsys;
66 - Zdz=Qoz./Qz;
67 - Evz=1+Xs-Zdz;
68 - Ev=min(Evz);
69 - Xsc=Xs/Ev;
70 - Qo=Qsys*Xsc;
71
72 %Step 5: Basic Calculations
73 %Assume the relative humidity leaving the cooling coil is 90% and do the
74 %.....calculations
75 - RHs=90;%
76 - [Hs,Ws]=TDB_RH((Ts-32)*5/9,RHs/100);% Enthalpy in J/kg
77 - ql=qt-qs;
78 - Wrz=ql./(4840*Qz)+Ws;
79 - Wr=sum(Wrz.*Qz)/Qsys;
80 - Tr=sum(Tz.*Qz)/Qsys;
81 - [Ho,Wo]=TDB_RH((To-32)*5/9,RHo/100); % Enthalpy in J/kg
82 - Wm=(Wo*Qo+Wr*(Qsys-Qo))/Qsys;
83 - Tm=(To*Qo+Tr*(Qsys-Qo))/Qsys; %Approximation
84 - qcs=Qsys*1.1*(Tm-Ts); %btu/hr
85 - qcl=Qsys*4840*(Wm-Ws);
86 - if qcs<0
87 -     qcs=0;
88 - end
89 - if qcl<0
90 -     qcl=0;
91 - end
92 - qct=qcs+qcl;
93
94

```

```
91 -     end
92 -     qct=qcs+qcl;
93
94     % Step 6: Cooling coil model
95 -     qcs=qcs;
96 -     qcl=qcl;
97 -     qct=qct;
98
99
100    % Step 7: Chiller model
101 -    [x,ChillerPower,xx]=ChillerModel(qct,qchiller,45,Two+8);
102
103    % Step 8: Total power
104 -    EnergyTotal=ChillerPower+FanPower+Reheat;
105
106    %Constraints
107    % for VAV box pressure
108 -    for i=1:size(Qz,1)
109 -        if Qz(i)>Qzd(i)*(Ps/Psd)^0.5
110 -            Constraintz(i)=1; % Penalty to kill this solution..
111 -        else
112 -            Constraintz(i)=0;
113 -        end
114 -    end
115 -    Constraint=sum(Constraintz);
116
117
```

GAHVACModel.m x VAVSystemModel.m* x

Appendix D: Optimization Using ASHRAE 62.1-2003 Peak Load, July 15th

Hour		Optimal			Non-Optimized/ Constant or Actual			
		TEMP	PRESSURE	(kW) ENERGY	Temp	Pressure	(kW) Energy	
8:00	8	56.5	2.52	71.1	55	3	75	
8:15	8.25	56.2	2.6	73.5	55	3	76.7	
8:30	8.5	55.8	2.54	75.3	55	3	78.2	
8:45	8.75	55.6	2.55	77.2	55	3	79.8	
9:00	9	55.4	2.53	79	55	3	81.3	
9:15	9.25	55.4	2.54	79.6	55	3	81.8	
9:30	9.5	55.2	2.49	80.2	55	3	82.4	
9:45	9.75	55	2.45	80.5	55	3	82.6	
10:00	10	55	2.44	81.3	55	3	83.4	
10:15	10.25	55	2.4	80.7	55	3	83	
10:30	10.5	55.4	2.49	79.5	55	3	82.5	
10:45	10.75	55.3	2.41	78.5	55	3	82	
11:00	11	55.1	2.33	77.4	55	3	81.5	
11:15	11.25	55	2.28	77.8	55	3	82.2	
11:30	11.5	55	2.26	78.5	55	3	81.2	
11:45	11.75	55	2.25	78.9	55	3	81.7	
12:00	12	55	2.24	79.6	55	3	82.3	
12:15	12.25	55	2.25	79.6	55	3	82.3	
12:30	12.5	55	2.25	79.9	55	3	82.6	
12:45	12.75	55	2.26	80	55	3	82.6	
13:00	13	55	2.27	80	55	3	82.6	
13:15	13.25	55	2.31	80.8	55	3	83.3	
13:30	13.5	55	2.35	81.5	55	3	83.9	
13:45	13.75	55	2.4	82	55	3	84.3	
14:00	14	55	2.44	82.8	55	3	84.9	
14:15	14.25	55	2.46	83.6	55	3	85.7	
14:30	14.5	55	2.46	83.9	55	3	86	
14:45	14.75	55	2.46	84.2	55	3	86.3	
15:00	15	55	2.52	85.9	55	3	87.9	
15:15	15.25	55	2.55	86.8	55	3	88.6	
15:30	15.5	55	2.58	87.5	55	3	89.2	
15:45	15.75	55	2.62	88.1	55	3	89.7	
16:00	16	55	2.65	88.9	55	3	90.3	
16:15	16.25	55.5	2.3	83.4	55	3	87	
16:30	16.5	57.2	2.27	83.2	55	3	90.8	
16:45	16.75	59.7	2.54	84.9	55	3	106.6	
17:00	17	--	--	--	55	3	--	

Appendix E: Optimization Using ASHRAE 62.1-2013 Peak Load, July 15th

Hour		Optimal			Non-Optimized/ Constant or Actual		
		TEMP	PRESSURE	(kW) ENERGY	Temp	Pressure	(kW) Energy
8:00	8	55	2.08	51.4	55	3	54.5
8:15	8.25	55	2.22	53.3	55	3	55.9
8:30	8.5	55	2.28	54.8	55	3	57.3
8:45	8.75	55	2.35	56.4	55	3	58.7
9:00	9	55	2.41	58	55	3	60.1
9:15	9.25	55	2.42	58.6	55	3	60.7
9:30	9.5	55	2.42	59.2	55	3	61.3
9:45	9.75	55	2.43	59.6	55	3	61.7
10:00	10	55	2.44	60.1	55	3	62.2
10:15	10.25	55	2.4	59.6	55	3	61.9
10:30	10.5	55	2.49	58	55	3	61.5
10:45	10.75	55.3	2.41	57.2	55	3	61
11:00	11	55.1	2.33	56.4	55	3	60.6
11:15	11.25	55	2.28	56.5	55	3	60.9
11:30	11.5	55	2.26	56.8	55	3	59.5
11:45	11.75	55	2.25	56.9	55	3	59.6
12:00	12	55	2.24	57.2	55	3	59.9
12:15	12.25	55	2.25	57.1	55	3	59.9
12:30	12.5	55	2.25	57.2	55	3	59.9
12:45	12.75	55	2.26	57.2	55	3	59.9
13:00	13	55	2.27	57.2	55	3	59.8
13:15	13.25	55	2.31	57.8	55	3	60.4
13:30	13.5	55	2.35	58.5	55	3	60.9
13:45	13.75	55	2.4	59	55	3	61.2
14:00	14	55	2.44	59.6	55	3	61.8
14:15	14.25	55	2.46	60.2	55	3	62.3
14:30	14.5	55	2.46	60.5	55	3	62.6
14:45	14.75	55	2.46	60.8	55	3	62.9
15:00	15	55	2.52	62	55	3	63.9
15:15	15.25	55	2.55	62.6	55	3	64.4
15:30	15.5	55	2.58	63.3	55	3	65
15:45	15.75	55	2.62	63.9	55	3	65.4
16:00	16	55	2.65	64.5	55	3	66
16:15	16.25	55.5	2.3	60.1	55	3	64.3
16:30	16.5	55	1.72	57	55	3	61.6
16:45	16.75	56.1	1.52	54.8	55	3	60.4
17:00	17	--	--	--	55	3	--

Appendix F: Optimization Using ASHRAE 62.1-2013 Partial Load, April 10th

Hour		Optimal			Non-Optimized/ Constant or Actual		
		TEMP	PRESSURE	(kW) ENERGY	Temp	Pressure	(kW) Energy
8:00	8	56.8	1.39	18.3	55	3	26.4
8:15	8.25	58.2	1.77	19.5	55	3	27.8
8:30	8.5	57.9	1.70	20.4	55	3	26.2
8:45	8.75	57.6	1.63	21.2	55	3	27.4
9:00	9	57.3	1.57	22.1	55	3	28.7
9:15	9.25	57.1	1.51	22.6	55	3	27.8
9:30	9.5	56.9	1.51	23.2	55	3	28.5
9:45	9.75	56.7	1.53	24.0	55	3	29.3
10:00	10	56.5	1.56	24.6	55	3	29.9
10:15	10.25	56.4	1.58	24.9	55	3	30.3
10:30	10.5	56.2	1.63	25.4	55	3	30.7
10:45	10.75	56.1	1.60	25.5	55	3	31
11:00	11	55.9	1.57	25.7	55	3	31.3
11:15	11.25	55.7	1.55	26.0	55	3	31.8
11:30	11.5	55.6	1.49	26.2	55	3	32.3
11:45	11.75	55.5	1.42	26.4	55	3	32.7
12:00	12	55.3	1.37	26.6	55	3	33.2
12:15	12.25	55.2	1.32	26.8	55	3	33.6
12:30	12.5	55.1	1.27	26.9	55	3	33.9
12:45	12.75	55.0	1.24	27.0	55	3	32.3
13:00	13	55.0	1.21	27.2	55	3	32.6
13:15	13.25	55.0	1.21	27.6	55	3	33.1
13:30	13.5	55.0	1.20	28.1	55	3	33.6
13:45	13.75	55.0	1.19	28.5	55	3	34.1
14:00	14	55.0	1.19	28.9	55	3	34.5
14:15	14.25	55.0	1.19	29.1	55	3	34.8
14:30	14.5	55.0	1.19	29.4	55	3	35.1
14:45	14.75	55.0	1.21	29.6	55	3	35.3
15:00	15	55.0	1.28	30.0	55	3	35.5
15:15	15.25	55.0	1.33	30.5	55	3	36
15:30	15.5	55.0	1.39	31.1	55	3	36.4
15:45	15.75	55.0	1.45	31.6	55	3	36.8
16:00	16	55.0	1.52	32.2	55	3	37.2
16:15	16.25	55.0	1.52	29.5	55	3	35.5
16:30	16.5	55.5	1.07	26.7	55	3	34.3
16:45	16.75	58.6	1.15	24.2	55	3	33
17:00	17	--	--	--	55	3	--