

Structural Dynamic Modelling of a Multi-Storey Shear Frame using Mass and Stiffness Addition

Opukuro S David-West

Centre for Engineering Research
Materials & Structures
University of Hertfordshire, Hatfield,
AL10 9AB, United Kingdom.

ABSTRACT

Measurements of stress/strain properties are not sufficient for high-speed operation systems and lightweight structures, instead, dynamic measurement/analysis are necessary for a comprehensive understanding of their characteristics. A shear frame structure was modelled using solid elements (ANSYS solid 187) and the discrepancy between the experimental and initial numerical results were very high. The three experimental modes were observed, and the suspected areas of high local stiffness were noted; these being the areas of connection between the floor plates and vertical pillars and ANSYS shell 181 was used to adjust the stiffness locally. Also, with appropriate engineering judgements, omitted masses compared with the physical structure were added locally using ANSYS mass 21 element type. In addition, the finite element model boundary conditions were carefully manipulated to predict the experiment condition. The process of model updating was good as the difference between the experimental and finite element results were reduced.

KEYWORDS: *model updating, finite element model, structural dynamics, ANSYS, vibration*

1.0 INTRODUCTION

Simulation of the behaviour of structure is now a very important tool in the present advanced technology, in the design and manufacturing sectors. Nowadays finite element techniques are commonly used to understand the characteristics of engineering structures; however, these numerical models are usually analysed based on idealized engineering properties. The precise prediction is not usually achieved with the first simulation, so there exist some discrepancies between experimental and numerical results.

*Corresponding author E-mail: o.david-west@herts.ac.uk

The accuracy of the finite element result is often obtained by comparing with experimental result tested on the physical system. If the correlation between the two is poor, then the numerical model must be adjusted so that the agreement between prediction and test result could improve; hence model updating. Parker, (2008) have observed that there are challenges in trying to identify the differences between the simulation and experimental results. The primary task in model updating is the choice of parameters to modify the mass, stiffness, and damping matrices in order to obtain better agreement between numerical and test results, and a survey of updating methods were given by Mottershead & Friswell, (1993).

Mottershead & Friswell, (1993) mention that for complex structures at least the first third of the eigenvalues of the finite element result should be accurate enough for design purpose and have highlighted a couple of model updating methods. Mares, *et al* (2003) use natural frequency errors and physical reasoning to update the finite element model of a GARTEUR SM-AG19 test structure. The modeling uncertainties were concentrated at the joints and constrained visco-elastic layers. Friswell, *et al* (2001), applied the methods of regularization, singular value decomposition, L-curves and cross-validation to model updating. The parameters of the model were adjusted using residuals between a measurement set and the corresponding model predictions.

Nalitolela, *et al* (1993) have presented the idea to use imaginary stiffness addition and simple structural modification to perturb a model and predict the dynamic characteristics; while Cha & de Pillis, (2001) used experimental data and the inclusion of masses to conduct updating of an analytical model. Bridges are indispensable components of the infrastructure of modern society. Zapico, *et al* (2003) added to this debate by updating an experimental bridge model with a geometric scale of 1:50 representing a continuous-deck motorway bridge, using the technique of mass addition. Brownjohn & Xia, (2000), used the sensitivity-based model updating method for the dynamic assessment of a curved cable-stayed bridge and Bien, *et al* (2002), highlighted the disadvantages of the conventional approach of exciting a bridge i.e. movement of large vehicles and reported that the use of an inertial vibration exciter gives a better result.

Ren & Chen, (2010) adopted the response surface approach to update the dynamic model of engineering structure; an objective function created between the experimental and numerically obtained natural frequencies was implemented in the optimisation algorithm to get the updated model. The process was observed to be efficient with faster convergence, compared to the sensitivity-based model approach; while Gordis & Papagiannakis, (2011), mentioned that the sensitivity-based model error localization and damage detection is limited by the relative differences in sensitivity magnitude among updating parameters and that artificial boundary conditions may be used to reduce this limitation. Shan, *et al* (2015) used the response surface characteristics and finite element analysis to obtain an updated model of a cable suspension bridge; the sensitivity parameters were extracted on the bases of variance analysis.

Khodaparast, *et al* (2008) addressed the issues of model adjustment of a test structure by perturbation technique on random variables of measured model response. Zang, *et al* (2004) reported using a combination of independent component analysis extraction of time domain data and artificial neural networks to detect structural damage. An inverse problem requires the use of a model and the uncertain parameters, Friswell, (2007) has highlighted the use of this approach for several issues such as health monitoring, including modeling error, environmental effects, damage localization and regularization. Titurus, *et al* (2003) proposed the use of generic elements as a viable tool

for damage detection and Sinha & Friswell, (2002) summarized the use of eigen-sensitivity approach in model updating and structural health monitoring.

Friswell, *et al* (1998) have discussed the use of damping and stiffness matrices in model updating by minimizes of the changes in the damping and stiffness matrices, with the objective that the measured data is reproduced. Ahmadian, *et al* (1998) used the inverse approach to parameters for the element model within allowable mass and stiffness matrices in model updating. Kozak, *et al* (2009) presented the model updating procedure based on minimization of an index called miscorrelation Index, which are introduced at error locations in the finite element model. Min, *et al* (2014) presented a sensitivity-based model updating technique for damped structures and the process involves data extracted from experiment and degree of freedom reduction in the finite element analysis.

Zapico-Valle, *et al* (2010), introduced a minimization of an error function for finite element model updating carried out by an adaptive sampling algorithm. Chouksey, *et al* (2014), updated the finite element model of a rotor shaft using the inverse eigen-sensitivity approach. Khanmirza, *et al* (2011) presented two techniques for the identification of mass–damping–stiffness of shear buildings; in the first method the dynamic parameters were obtained from a forced vibration test and the second technique was an inverse analysis to identify the dynamic characteristics. Lepoittevin & Kress, (2011) simulated the free – free boundary conditions of bare and damped samples and predicted the resonance frequencies and modal loss factors from the numerical analysis.

In this study experimental modal analysis was performed on a three storey shear frame using the shaker, accelerometer, charge amplifier and fast Fourier analyser. The three expected natural frequencies were obtained, and mode shapes observed with a stroboscope. These results were compared with the ones obtained from finite element analysis using ANSYS 17 finite element code. The discrepancies between the experiment and numerical results were reduced by updating the numerical model. The mass and stiffness matrices of the finite element model were manipulated respectively by appropriate engineering judgement with a dot element (mass 21) and shell element (shell 181) as ghost or imaginary element, that is elements that have contributed to the final results but are not seen when the elements/mode shapes are displayed. In addition, the boundary conditions of the finite element model were carefully controlled to match that of the experiment.

2.0 GOVERNING EQUATIONS

The dynamic properties of a system can be represented if the basic properties are assumed to be discretised and considered separately [Maia & Silva, 1997]. The spatial distribution of mass, stiffness and damping properties are illustrated in terms of matrixes of mass $[M]$, stiffness $[K]$ and damping $[C]$ (for a viscously damped model) or $[D]$ (for hysterically damped model). If the degree of freedom (DOF) is illustrated by the time-dependent displacement $x_i(t)$ with a time-dependent applied force, $f_i(t)$. A general dynamic analysis will solve the equation of motion which gives the time dependent response of every node point in the structure by including inertial and damping forces in the equation. The model can be illustrated using the Newton's second law of motion and for hysterically damped model,

$$[M]\{\ddot{x}(t)\} + [K]\{x(t)\} + i[D]\{x(t)\} = \{f(t)\} \quad (1)$$

Taking consideration of viscous damping,

$$[M]\{\ddot{x}(t)\} + [C]\{\dot{x}(t)\} + [K]\{x(t)\} = \{f(t)\} \quad (2)$$

If the solution is as illustrated in equation (3),

$$\{x(t)\} = \{X\}e^{i\omega t} \quad (3)$$

where, $\{X\}$ is a time-dependent complex amplitudes (Maia & Silva, 1997), then spatial model can be presented as a generalized eigenvalue problem (Maia & Silva, 1997) as in equation (4).

$$[[K] - \omega^2[M] + i[D]]\{X\} = \{0\} \quad (4)$$

where, D is the structural damping matrix.

Most engineering systems designers are interested in the natural frequencies and mode shapes of vibration of the system. If the damping is ignored and considering a free vibration multi-degree of freedom system, the dynamic equation becomes.

$$[M]\{\ddot{x}\} + [K]\{x\} = \{0\} \quad (5)$$

If the displacement vector $\{x\}$ has the form $\{x\} = \{X\} \sin \omega t$, then the acceleration vector is $\{\ddot{x}\} = -\{X\}\omega^2 \sin \omega t$ and substituting into equation (5) gives the eigenvalue equation.

$$([K] - \omega^2[M])\{X\} = \{0\} \quad (6)$$

Each eigenvalue has a corresponding eigenvector and the eigenvectors cannot be null vectors, hence,

$$|[K] - \omega^2[M]| = \{0\} \quad (7)$$

Equation (6), represent an eigenvalue problem, where ω^2 is the eigenvalue and $\{X\}$ the eigenvector (or the mode shape). The eigenvalue is the square of the natural frequency of the system.

The structural damping matrix in ANSYS finite element code is analysed using the relationship,

$$D = \alpha_s * M + \beta_s * K \quad (8)$$

where α and β are the damping proportionality constants corresponding to mass and stiffness matrix respectively. The subscript 's' refers to structural damping. Structural damping coefficient of 0.05 used for both α_s and β_s for purpose of finite model updating of the shear frame structure.

3.0 STRUCTURAL DESCRIPTION

The shear frame is made of steel. It consists of two metal pillars connected by three steel metal strips that are at three different levels. The connection from the pillars to the metallic strips was with metallic tabs screwed through the pillars into the metallic strips. The bases of the pillars were firmly bolted to the table foundation.



Figure 1: Photograph of the shear frame structure.

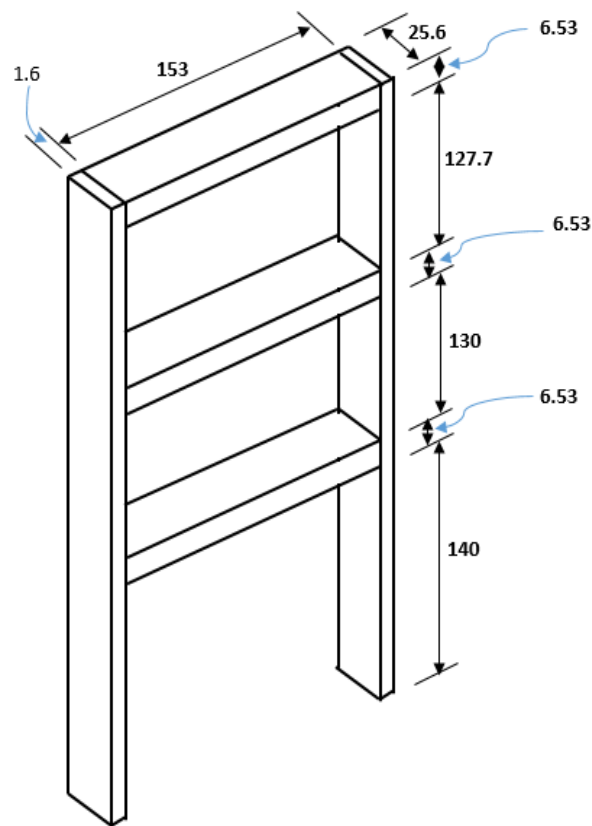

Figure 2: Sketch of the shear frame structure with all the dimensions in mm.

The photograph of the shear frame is shown in Figure (1) and the schematic of the shear frame with the dimension in millimetres presented in Figure (2). This three-storey system is expected to present three modes of vibration because it possesses three degree of freedom, hence we may presume that the number of degrees of freedom is equal to the number of storeys on a building for this illustration.

4.0 EXPERIMENTAL PROCEDURE AND RESULTS

The vibration response of the three-storey shear frame with bolted boundary conditions under the excitation of a shaker was measured with a magnetic accelerometer connected to a charge amplifier and the Fourier analyser.

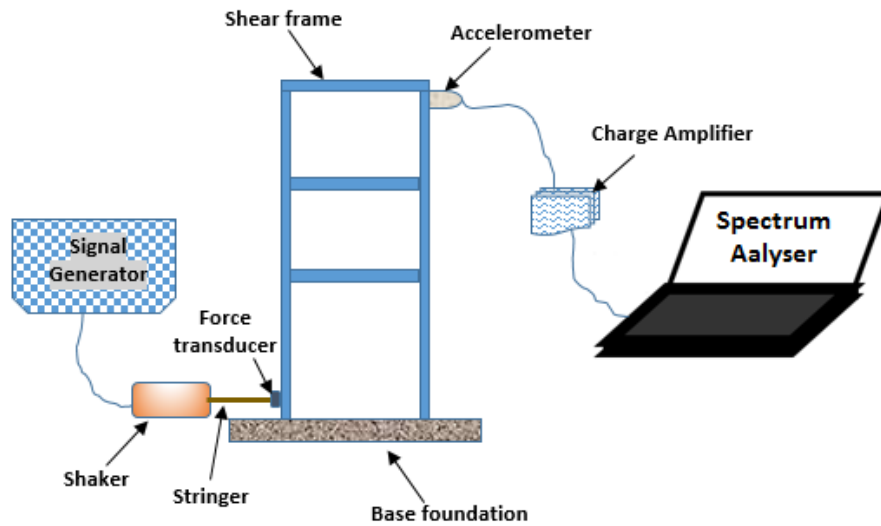

Figure 3: Set-up of the experimental arrangement.

The schematic of the test arrangement is as shown in Figure (3). The input frequency of the shaker via the stinger and force transducer was set by the signal generator. The accelerometer with magnetic base attached to the top of the three-storey frame; transfers the measured data to be display on the screen of the spectrum analyser via the charge amplifier and the resonant frequencies determined. As vibration of the shear frame was varied through the input from the shaker, a stroboscope was used to confirm the nodes and anti-nodes of the oscillation along the sides of the frame. The photograph of the stroboscope is shown in Figure (4).



Figure 4: Stroboscope

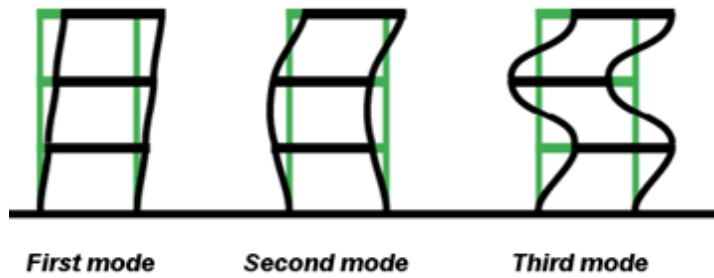

Figure 5: Experimental mode shapes



Figure 6: Frequency response function – screen shut of oscilloscope Fourier analyser.

Table 1: Natural frequencies from test result

Mode 1	Mode 2	Mode 3
16.75 Hz	50.00 Hz	75.75 Hz

The three modes shape of the shear frame observed with the stroboscope are sketched and presented in Figure (5) and frequency response function extracted with the accelerometer shown in Figure (6). Each peak in the frequency response plot correspond to the natural frequency of the mode’s shapes in the respective order and the values of the natural frequencies shown in Table 1.

5.0 INITIAL FINITE ELEMENT SIMULATION

The initial finite element model of the three-storey shear frame was created as a three-dimensional linear elastic model using the mechanical properties of steel shown in Table 2 in ANSYS 17 code. The element used for meshing was SOLID187; it is a higher order 3-D element, defined by 10 nodes and three translational (x, y and z) degree of freedom at each node.

Table 2: Material properties of steel

Item	Density	Modulus	Poisson ratio
Steel	7830 kg/m ³	210 G Pa	0.33

The three storey steel shear frame structure was bolted to the base structure (a table) via the blocks as shown in the picture of Figure 1 and this was represented in the finite element simulation as fixed condition for the nodes attached to the bottom lines i.e. by setting the degrees of freedom in the x, y and z directions to zero. The finite element model has 7461 elements, with the element edge length of 6 mm and Figure (7) shows the finite element discretisation for the shear frame and the global coordinate system, which by default will corresponds to the element coordinate system.

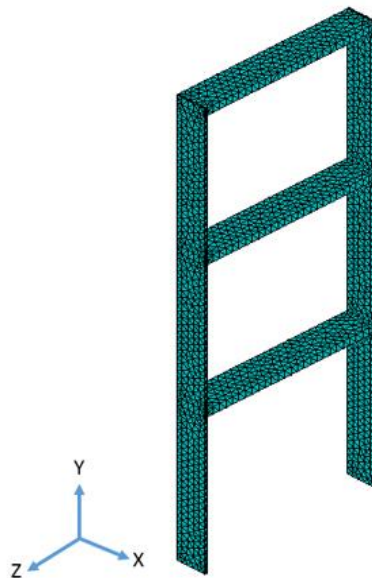

Figure 7: Mesh discretisation of the three-storey shear frame.

Table 3: Natural frequencies obtained for initial finite element model

Mode Number	Frequency (Hz)
1	18.4
2	54.5
3	55.2

The realization of the elastic modes and natural frequencies were achieved with Lanczos tool in ANSYS 17 finite element code to conduct the dynamic analysis. Table 3 shows the natural frequencies obtained for the first three modes. The fundamental frequency was obtained as 18 Hz and the other two seems to be very close modes in the vicinity of 55 Hz. That is from this initial finite element results, the second and third eigenvalues were repeated and hence the corresponding mode shapes were not unique.

6.0 INITIAL RESULTS AND LOCALISATION OF UPDATING PARAMETERS

The results as regards the natural frequencies obtained from experiment and finite element are presented in Table 4. The initial finite element model seems to be relatively stiff with respect to the fundamental mode and the second one. Also, the finite element second and third modes are seen to be closed from the results of the initial analysis.

Table 4: Comparison of experimental and initial numerical results

Mode number	Frequency (Hz)		Percentage change [%] $\left \left(\frac{f_2 - f_1}{f_1} \right) \right \times 100$
	Experiment, f_1	Finite element analysis, f_2	
1	16.75	18.4	9.9
2	50.00	54.5	9.0
3	75.75	55.2	27.1

In order to successfully match the simulation results with that of the experimental ones, it is important to fully consider all aspects of the experimental setup. This includes ensuring dimensional accuracy of the finite element model, and accounting for additional masses of components within the system that would cause the vibration characteristics to be altered. There also exist changes in the structural stiffness at various locations which was not taken into considerations. Table 5 summarized the assumptions of the initial finite element model.

Table 5: Initial model assumptions.

Type	Description
Geometric shape	The parts such as the hook, taps and screws were not included in the geometric model.
Connections	Connections between parts were treated as one full member.
Boundary conditions	Based boundary was taken as fixed points nodes.
Modulus	Young's modulus of steel material could vary between 190 – 215 G Pa; used 210 GPa
Density	Density of steel material could vary between 7700 – 8000 kg/m ³ ; used 7830 kg/m ³
Thickness	Assumed uniform thickness along the cross-section of each part.
Stiffness	Variations at different locations due to connections of parts not taken into account.

It can therefore be concluded that there was a problem with inadequate modelling which overestimated the stiffness as is evident from the results of the first and second natural frequencies obtained from the initial finite element model. The variation of the masses such as addition of the metallic tabs / hook with the use of dot elements were not adequately taken into consideration. Also, the changes in local stiffness due to the different levels of the shear frame will need to be considered in the process of updating.

7.0 MODEL UPDATING PROCEDURE

The primary task in finite element model updating is the ability to apply engineering judgements to tune the model and satisfactorily predict the characteristics of the structure; hence it is very important to identify sufficient model updating parameters. These parameters are usually the physical variables of the model which are adjusted at the element level. As a preliminary adjustment, the finite element model was material properties were modified globally as in Table 6 to improve the model.

Table 6: Justification for mechanical properties selection

Type of check	Action	Justification
Young's modulus	Used 200 G Pa	Steel stated modulus between 190 – 215 G Pa.
Density	Used material density of 7830 kg/m ³ .	Steel material density range between 7700 – 8000 kg/m ³ .

The photograph of the metallic tab with hook and the screws connecting to the level plates (floors) of the shear frame is as shown in Figure (8). The weight of the solid metallic tab was obtained using 'METTLER AE200' digital weighing instrument and use for purpose of the model adjustment. The mass was added to the finite element model across 4 nodes in the regions where tabs / hooks are meant to be present. ANSYS mass 21 element was used to implement this.



Figure 8: Shear Frame Hook

At one-tab location the mass added per node was 0.003 kg for the four nodes the total is 0.012 kg which is approximately the mass of a solid tab. After adding the masses to the model and running a second modal analysis, it was found that the addition of the masses resulted in a negligible effect on the natural frequencies of the structure. Due to this, it was determined that the stiffness of the model should be modified in order to alter the natural frequencies.

8.0 MODEL ADJUSTMENT – MASS AND STIFFNESS ADDITION

To add stiffness to the current finite element model 'Shell 181' element was used and applied with negligible element thickness in ANSYS 17 finite element code. This element type was selected as it well suited to both linear and non-linear strain applications; it has six degrees of freedom at each node: translations in the x, y, and z directions, and rotations about the x, y, and z axes.

Considering the initial modes shapes of the shear frame, it was observed that the stiffness around the joints of the vertical pillars and the level plates (floors), and the area near the fixed base are quite different from other parts of the structure. In structural finite element analysis, the stiffness matrices are formulated by equation (9), which is available in most literatures on finite element analysis.

$$[k]_e = \int [B]^T [E] [B] dv \quad (9)$$

Where, \mathbf{B} is the strain – displacement transformation matrix and \mathbf{E} is material property matrix. Hence, as can be seen from this expression the material young's modulus is an important parameter in the formation of the element stiffness matrices. Local stiffness was added at the various levels shown in Figure (9) with the ANSYS Shell 181 element.

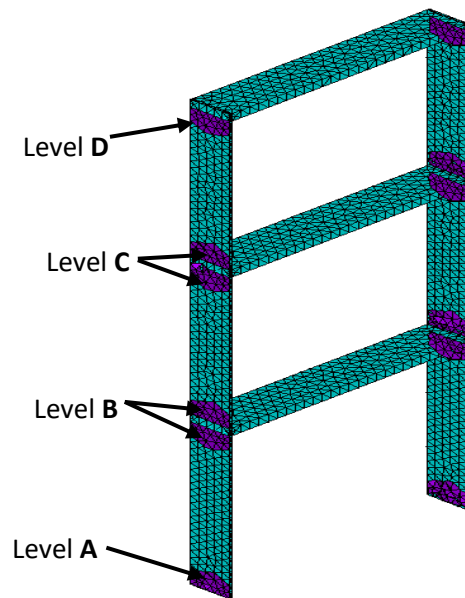

Figure 9: Discretisation of model, mass addition with local stiffness adjustment.

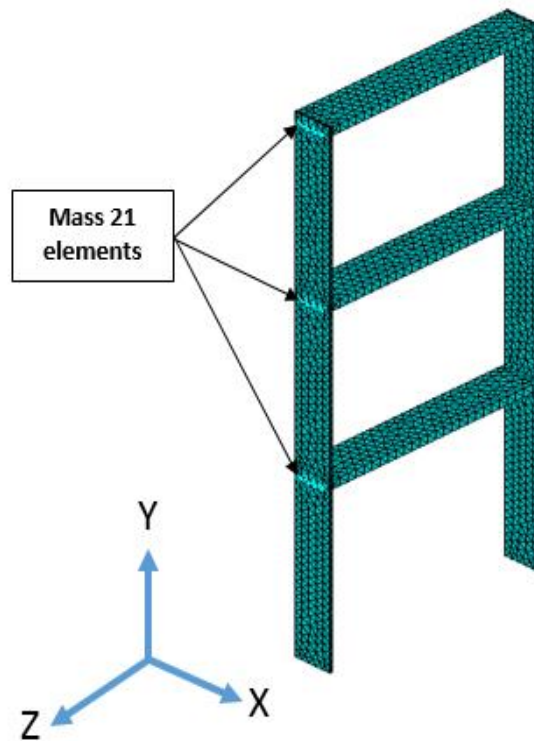

Figure 10: Discretisation of model, mass addition and coordinate system.

In this study the lost mass in the initial model were added with the dot element of ANSYS 17 known at ‘Mass 21’. That is mass of the metallic / hook obtained by weighing with a digital scale to be approximately 0.012 kg, was added using ANSYS mass 21 element as distributed mass (0.003 kg per node on four nodes) along the appropriate locations as shown in Figure (10) and the local stiffness at certain locations of the shear frame model change using ANSYS ‘Shell 181’ element type as presented Figure (9).

Also in Figure (10) is the global coordinate system for the updated finite element model and it also corresponds to the element coordinate system; as the vibration energy is transmitted through the shaker to the shear frame in the z-direction, the x-direction for the finite element model was set to zero. Table 7 shows the comparison between the test natural frequencies and the ones obtained from finite element analysis. The percentage differences between the results with respect to the experimental results have significantly reduced. The percentage difference for the fundamental, second and third modes were 6.6, 4.0 and 5.2 respectively, as can be seen in Table 7.

Table 7: Comparison of Experimental and Updated Numerical Results

	Natural frequency (Hz)		Percentage change [%] $\left \left(\frac{f_2 - f_1}{f_1} \right) \right \times 100$
	Experiment, f_1	Finite element analysis, f_2	
Mode 1	16.75	17.85	6.6
Mode 2	50.00	52.70	4.0
Mode 3	75.75	79.68	5.2

Table 8: Properties of the updated model

Modulus (G Pa)	Density (kg/m ³)	Damping constant	Method	Mass addition kg	Additional modulus	
					Location	Modulus (N/m ²)
200	7830	0.05	Mass and stiffness sensitivity analysis	0.012	A	200
					B	50
					C	50
					D	50

The material properties of the updated numerical model are as presented in Table 8, that is the modulus of 200×10^9 N/m² and density of 7830 kg/m³; based on engineering judgement of the physical structure and the experimental mode shapes the mass and stiffness matrices were adjusted at the locations shown in Figures (9) and (10). The mass was added to four nodes at each location, the load per node was 0.003 kg. The addition of stiffness was implemented at the locations **A**, **B**, **C** and **D** shown in Figure (10) using ANSYS shell181 with the moduli values of 200 N/m², 50 N/m², 50 N/m² and 50 N/m² at the respective locations.

Table 9: Experimental and finite element analysis mode shapes.





Experiment	Finite element analysis
 <p data-bbox="461 645 547 676">Mode 1</p>	 <p data-bbox="1031 654 1117 685">Mode 1</p>
 <p data-bbox="461 1059 547 1090">Mode 2</p>	 <p data-bbox="1031 1084 1117 1115">Mode 2</p>
 <p data-bbox="461 1422 547 1453">Mode 3</p>	 <p data-bbox="1031 1442 1117 1473">Mode 3</p>

Table 9 show good similarity between the experimental and finite element mode shapes. The masses such as that of the metallic taps omitted in the initial model were added with the use of dot elements and with the variation by trial and error of local stiffness at the joints and the lower parts of the frames with the shell elements.

9.0 SUMMARY

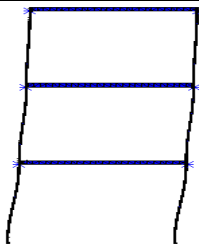
When creating the finite element model of a structure based on available data and appropriate engineering judgements where necessary, there is no guarantee that the initial model can reasonably predict the modal properties (natural frequencies and mode shapes).

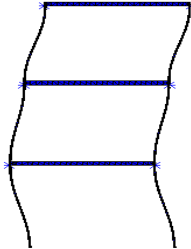
According to Mottershead, et al (2011) common sources of discrepancies between these results are:

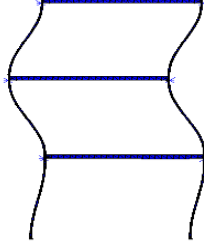
- Idealisation Errors
- Discretisation Errors
- Erroneous Assumptions

In this report the author has evaluated the accuracy of a finite element model, with the use of elements not displayed in the final results to adjust the mass and stiffness matrices.

The three mode shapes and natural frequencies of a three-storey shear frame were located experimentally using a stroboscope and the fast Fourier analyser respectively. A comparison between the experimental results and the initial finite element analysis results revealed errors in the dynamics properties (i.e. frequencies and mode shapes).

To reconcile or reduce the degree of mismatch, manually tuning of the finite element model was conducted after critical observation of the mode shapes with the aim to identify zones of differences in the stiffness. Shell 181 element of ANSYS finite element code was used to locally adjust the model stiffness around the zones of connections between the shear frame floors and the pillars. Also, the boundary conditions of the numerical model were controlled to closely match that of the experimental performance. This technique of stiffness addition significantly improved the correlation between the numerical and the experimental results.

10.0 REFERENCES

- Ahmadian, H., Friswell, M. I. & Mottershead, J. E. (1998). Minimization of the Discretization Error in Mass and Stiffness Formulations by an Inverse Method. *Int. Journal for Numerical Methods in Engineering*, Vol. 41, 371 -- 387.
- Bien, J., Krzyzanowski, J., Poprawski, W., Skoczynski, W. & Szymkowski, J. (2002). Experimental study of bridge structure dynamics characteristics using Periodic Excitation. *Proceedings of ISMA*, Vol. 2, pp 555 – 562.
- Brownjohn, J. M. W. & Pin-Qi Xia (2000). Dynamic assessment of curved cable-stayed bridge by model updating. *Journal of Structural Engineering*, pp 252 – 206.
- Cha, P. D. & de Pillis, L. G. (2001). Model updating by adding known masses, *Int. J. Numer. Meth. Engng*; 50:2547 – 2571.
- Chouksey, M., Dutt, J. K. & Modak, S. V. (2014). Model updating of rotors supported on journal bearings. *Mechanism and Machine Theory* 71, 52–63.
- Friswell, M. I., Inman, D. J. Pilkey, & D. F. (1998). The direct updating of damping and stiffness matrices. *AIAA Journal*, Vol. 36, No. 3, March 1998, pp. 491-493.
- Friswell, M. I. (2007). Damage identification using inverse methods, *Phil. Trans. R. Soc. A* 365, 393–410.

- Friswell, M. I., Mottershead, J. E. & Ahmadian, H. (2001). Finite-element model updating using experimental test data: parametrization and regularization. *Phil. Trans. R. Soc. Lond. A*, 359, 169 – 186.
- Gordis, J. H. & Papagiannakis, K. (2011). Optimal selection of artificial boundary conditions for model update and damage detection. *Mechanical Systems and Signal Processing*, Vol 25, (5), 1451 – 1468.
- Khanmirza, E., Khaji, N. & Majd, V. J. (2011). Model updating of multistory shear buildings for simultaneous identification of mass, stiffness and damping matrices using two different soft-computing methods. *Expert Systems with Applications* 38, 5320–5329.
- Khodaparast, H. H., Mottershead, J. E. & Friswell, M. I. (2008). Perturbation methods for the estimation of parameter variability in stochastic model updating. *Mechanical Systems and Signal Processing* 22, 1751– 1773.
- Kozak, M. T., Ozturk, M. & Ozguven, H. N. (2009). A method in model updating using Mis correlation Index sensitivity, *Mechanical Systems and Signal Processing* 23, 1747– 1758.
- Lepoittevin, G. & Kress, G. (2011). Finite element model updating of vibrating structures under free–free boundary conditions for modal damping prediction, *Mechanical Systems and Signal Processing* 25, 2203–2218.
- Maia, N. M. M. & Silva, J. M. M. (1997). Theoretical and experimental modal analysis. Taunton: *Research Studies Press and John Wiley and Sons*, Somerset.
- Mares, C., Mottershead, J. E. & Friswell, M. I. (2003). Results obtained by minimising natural-frequency errors and using physical reasoning. *Mechanical Systems and Signal Processing*, 17(1), 39–46.
- Min, C. H., Hong, S., Park, S. Y. & Park, D. C. (2014). Sensitivity-based finite element model updating with natural frequencies and zero frequencies for damped beam structures, *Int. J. Nav. Archit. Ocean Eng.* 6:904~921.
- Mottershead, J. E. & Friswell, M. I. (1993). Model updating in structural dynamics: A survey, *Journal of Sound and Vibration* 167(2), 347 – 375.
- Mottershead, J., Link, M. & Friswell, M. (2011). The sensitivity method in finite element model updating: A tutorial, *Mechanical Systems and Signal Processing*, vol. 25, no. 7, pp. 2275-2296.
- Nalitolela, N, Penny, J. E. T. & Friswell, M. I. (1993). Updating model parameters by adding an imagined stiffness to the structure, *Mechanical Systems and Signal Processing* 7(2), 161 – 172.

- Parker, W. S. (2008) Does matter really matter? Computer simulations, experiments, and materiality, *Synthese*, vol. 169, no. 3, pp. 483-496.
- Ren, W. & Chen, H. (2010). Finite element model updating in structural dynamics by using the response surface method. *Engineering Structures* 32, 2455 -- 2465.
- Shan, D., Li, Q., Khan, I., & Zhou, X. (2015). A novel finite element model updating method based on substructure and response surface model. *Engineering Structures* 103, 147–156.
- Sinha, J. K. & Friswell, M. I. (2002). Model updating: A tool for reliable modeling, design modification and diagnosis. *The Shock and Vibration Digest*, Vol. 34, No. 1, January 2002, pp 27-35.
- Titurus, B., Friswell, M. I. & Starek, L. (2003). Damage detection using generic elements: Part I. Model updating. *Computers and Structures* 81, 2273–2286.
- Zang, C., Friswell, M. I. & Imregun, M. (2004) Structural Damage Detection using Independent Component Analysis, *Structural Health Monitoring*, Vol 3(1), pp: 69–83.
- Zapico-Valle, J. L., Alonso-Cambor, R., Gonzalez-Martinez, M. P. & Garcia-Dieguez, M., (2010). A new method for finite element model updating in structural dynamics *Mechanical Systems and Signal Processing* 24, 2137–2159.
- Zapico, J L., Gonzalez, M P., Friswell, M I., Taylor, C A. & Crewe, A J. (2003). Finite element model updating of a small-scale bridge, *Journal of Sound and Vibration* 268, 993–1012